

Online Research @ Cardiff

This is an Open Access document downloaded from ORCA, Cardiff University's institutional repository: <http://orca.cf.ac.uk/105185/>

This is the author's version of a work that was submitted to / accepted for publication.

Citation for final published version:

Fox, Kevin 2018. Deconstructing the cortical column in the barrel cortex. *Neuroscience* 368 , pp. 17-28. 10.1016/j.neuroscience.2017.07.034 file

Publishers page: <http://dx.doi.org/10.1016/j.neuroscience.2017.07.0...>
<<http://dx.doi.org/10.1016/j.neuroscience.2017.07.034>>

Please note:

Changes made as a result of publishing processes such as copy-editing, formatting and page numbers may not be reflected in this version. For the definitive version of this publication, please refer to the published source. You are advised to consult the publisher's version if you wish to cite this paper.

This version is being made available in accordance with publisher policies. See <http://orca.cf.ac.uk/policies.html> for usage policies. Copyright and moral rights for publications made available in ORCA are retained by the copyright holders.



Please cite this article in press as: Fox K. Deconstructing the cortical column in the barrel cortex. *Neuroscience* (2017), <http://dx.doi.org/10.1016/j.neuroscience.2017.07.034>

Neuroscience xxx (2017) xxx–xxx

DECONSTRUCTING THE CORTICAL COLUMN IN THE BARREL CORTEX

KEVIN FOX *

School of Biosciences, Cardiff University, United Kingdom

Abstract—The question of what function is served by the cortical column has occupied neuroscientists since its original description some 60 years ago. The answer seems tractable in the somatosensory cortex when considering the inputs to the cortical column and the early stages of information processing, but quickly breaks down once the multiplicity of output streams and their sub-circuits are brought into consideration. This article describes the early stages of information processing in the barrel cortex, through generation of the center and surround receptive field components of neurons that subserve integration of multi whisker information, before going on to consider the diversity of properties exhibited by the layer 5 output neurons. The layer 5 regular spiking (RS) neurons differ from intrinsic bursting (IB) neurons in having different input connections, plasticity mechanisms and corticofugal projections. In particular, layer 5 RS cells employ noise reduction and homeostatic plasticity mechanism to preserve and even increase information transfer, while IB cells use more conventional Hebbian mechanisms to achieve a similar outcome. It is proposed that the rodent analog of the dorsal and ventral streams, a division reasonably well established in primate cortex, might provide a further level of organization for RS cell function and hence sub-circuit specialization.

This article is part of a Special Issue entitled: Barrel Cortex. © 2017 Published by Elsevier Ltd on behalf of IBRO.

Key words: plasticity, regular spiking, intrinsic bursting, C-hernoff information, layer 5, homeostatic.

	Contents	
Introduction		00
Input signal processing		00
Layer 4		00
Layer 5		00
Intercolumnar and intracolumnar processing		00
Signaling between columns		00
Information processing within the column		00
Barrel cortex output streams		00

Subcortical and corticocortical projections	00
Plasticity mechanisms in RS and IB cells	00
Information processing in RS and IB cells	00
Corticocortical projections: dorsal and ventral streams	00
Ventral stream	00
Dorsal stream	00
Septal and barrel projections within dorsal and ventral streams	00
Subcortical projections	00
Concluding remarks	00
Acknowledgments	00
References	00

INTRODUCTION

It has been sixty years since Mountcastle first described the cortical column in the cat somatosensory cortex (Mountcastle, 1957), since when columns have been considered the versatile modular building block composing the functional architecture of the cerebral cortex. In support of this view, examples of columnar structure can be found in the visual, auditory, motor and even the inferotemporal cortex (Hubel and Wiesel, 1963; Fujita et al., 1992; Kanold et al., 2014). But what is the function of a cortical column? Reviews in recent years have noted the relatively slow progress in reaching a conclusion on this question (Sincich and Horton, 2005). The cortical column is clear to see in the barrel cortex of rodents and one might imagine that if the function for a column were to be discovered anywhere it might be discovered here. The process might be aided by the fact that, unlike in the visual cortex where orientation, ocular dominance and retinotopic maps are combined, only a single type of topographic map is represented in the barrel cortex.

A classic approach to understanding the function of a single column would be to define its transfer function (Fig. 1A). However, several factors mitigate against a simple solution. First, there are multiple inputs to a column not just one; for the barrel cortex, this might be simplified as two main sensory inputs, one from ventroposterior medial nucleus (VPm) and one from posterior medial (POM). Second, there are multiple outputs and not just from a single source but from multiple layers within the column (Fig. 1B). Some of these outputs will project to neighboring barrel columns in order to integrate information across the whisker array. Third, the forward transform is embedded within numerous feedback loops that propagate information back from the outputs to the inputs (for example via projections to the thalamus). In the behaving animal a

*Address: School of Biosciences, Cardiff University, Museum Avenue, Cardiff CF10 3AX, United Kingdom.

E-mail address: Foxkd@cardiff.ac.uk

Abbreviations: CRF, center receptive field; IB, intrinsic bursting; M1, primary motor cortex; MII, secondary motor cortex; PFC, prefrontal cortex; POM, posterior medial; PPC, posterior parietal cortex; PR, parietal rhinal; PV, parietal ventral; ROC, receiver operating characteristic; RS, regular spiking; SRF, surround receptive field; TNF α , tumor necrosis factor alpha; VPm, ventroposterior medial nucleus.

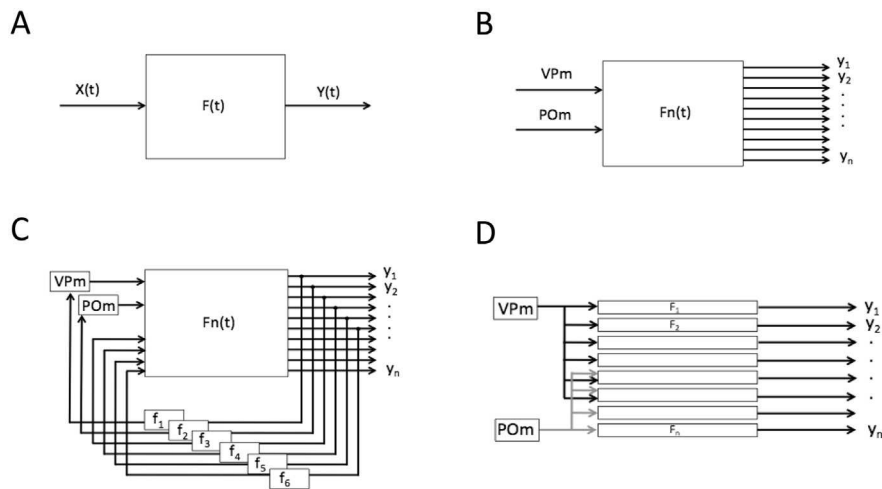

Fig. 1. Deconstruction of a cortical column. (A) The transfer function of a system $F(t)$ can be defined as the output time function $y(t)$ divided by the input time function $x(t)$. (B) In the barrel cortex there are at least two major sensory inputs from the thalamus (VPm and POm) and many outputs projecting cortically between barrels, sub cortically and to other cortical areas (y_1 to y_n). (C) The outputs of the system also feedback on the input to the column (VPm and POm) as well as to other elements in the column that receive thalamic input with modifying functions f_n (only six feedback loops are shown for clarity). (D) The single column is broken down into output columns with varying degrees of input from VPm and POm (the feedback loops are omitted for clarity).

further mechanical feedback loop is generated by the whiskers interacting with the environment due to movements guided by the barrel cortex during active exploration (Fig. 1C).

One method for understanding the function of a cortical column might be to detect the presence of a different quality of sensory response at the output compared to the input. For example, in the visual cortex orientation selectivity and binocularity are synthesized from the geniculate input that lacks either property. However, in the barrel cortex this approach has proved more difficult, primarily because many of the response properties of barrel cortex neurons are present in the thalamic neurons that project to them, such as multi-whisker receptive fields, direction selectivity and global motion selectivity (Armstrong-James and Fox, 1987; Simons and Carvell, 1989; Armstrong-James and Callahan, 1991; Bruno and Simons, 2002; Jacob et al., 2008; Ego-Stengel et al., 2012). The role of the cortical column in these processes may be to function as part of a feedback loop to the thalamus that tunes and amplifies these properties rather than to generate them *de novo*.

An alternative and complementary method to understanding how the cortical column might work is to describe the pathways within the column and trace the route taken by the signal through the column (Armstrong-James et al., 1992; Feldmeyer et al., 2002, 2005; Lubke and Feldmeyer, 2007) concentrating on the early stages of processing. The progress of information flow to neighboring barrels can also be considered as well as the interactions resulting when the signaling streams from two neighboring whiskers collide. It is possible to use this approach in the barrel cortex because responses to a short duration mechanical impulse are brief and time-locked. One limitation of this method arises from the fact

that the barrel column has many different projection targets and it is likely that different signals are processed differently within different output streams (Fig. 1D). This article summarizes the results of experiments where signals have been tracked within and between columns, before going on to explore the many output streams and sub-circuits into which this input pathway feeds. As a first pass, outputs that project to other cortical areas and outputs that project subcortically are considered including a description of their different types of plasticity. Finally, the dorsal and ventral processing streams of the cortico-cortical outputs are considered.

INPUT SIGNAL PROCESSING

The VPm and POm nuclei of the thalamus provide the two major signaling pathways to the barrel cortex that carry information from the whiskers. How do these inputs contribute to the receptive field

properties of cortical neurons and how does the signal propagate within the cortex? Almost all neurons in the rat and mouse barrel cortex respond to more than a single whisker, but cells in layers 2/3 and 4 usually respond far more strongly to their principal whisker (the whisker related to the barrel-column in which they reside) than any other. The fall off in response is quite marked for layer 4 cells (Fig. 2A) located in barrel-columns and less so for septal-column neurons. The septal cells lie between the walls of the barrels in layer 4 and the cells they are aligned with in the supra- and infra-granular layers above and below have been described as a separate column system (Alloway, 2008). Septa are easier to isolate in the rat compared to the mouse and the data described in this section largely originates from recordings in rat barrel cortex. It is common to refer to the principal whisker response as the center receptive field (CRF) and the other components as the surround receptive field (SRF). A number of studies over the years have elucidated the origins of the CRF and SRF components of the cells in layers 2/3, 4 and 5 and these aspects of receptive field structure are useful in tracing how the signal propagates within the cortical structure as described below.

Layer 4

The first clue about the origin of the center/surround components came from a consideration of the latency of response to stimulation. Rapid stimulation of a whisker with a short duration deflection evokes a rapid neuronal response (within 10 ms) in layer 4 and layer 5B of the principal barrel column for that particular whisker (Armstrong-James and Fox, 1987; Armstrong-James et al., 1992). The response then radiates out to the neigh-

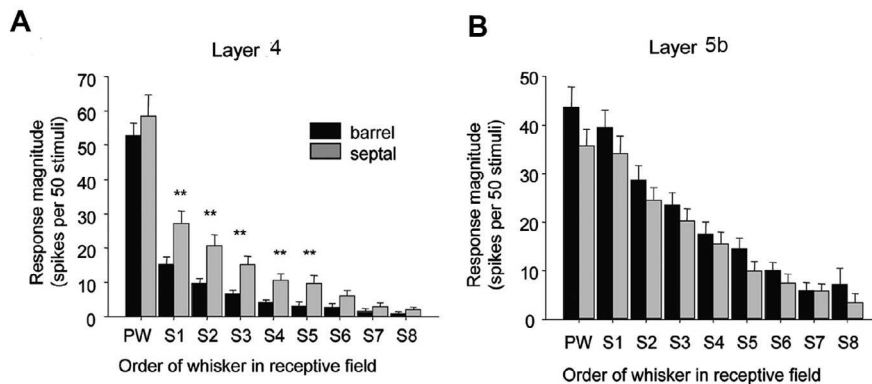

Fig. 2. Receptive fields of layer 4 and layer 5B cells. (A) The principal whisker (PW) response dominates the receptive field of the barrel located layer 4 cells (black bars). The surround receptive field responses (S1–S5) are larger for septal located layer 4 cells (gray bars) than for barrel located layer 4 cells ($p < 0.01$, rat barrel cortex). (B) The surround receptive field responses of layer 5B cells are larger than those of layer 4 cells shown in A (note that S3 is 50% of the PW response for the layer 5B cells whereas even S1 is only 32% of the PW response for the layer 4 barrel cell). Septal and barrel located layer 5B neurons have indistinguishable surround receptive field response magnitudes.

boring barrels over the next 50 ms or so. This pattern of activation strongly suggests that the short-latency responses in the principal whisker's barrel-column is the source of excitation for surrounding barrel-columns and therefore that the CRF is generated by the direct input from the lemniscal pathway (VPm) and the SRF is generated from intracortical connections from neighboring columns (Fig. 3A). This view is corroborated by experiments showing that if the principal barrel is ablated, the longer latency responses to surround whisker stimulation are lost in surrounding barrels (Fox, 1994) (Fig. 3B). Furthermore, if a row of small lesions separates two barrels, each barrel loses its representation of the severed whisker while retaining its other receptive field components (Fox, 1994) (Fig. 3C).

Two further experiments confirmed that intracortical connections running between the barrel columns are responsible for the SRFs of cortical neurons (Fig. 3). First, if a single barrel is inactivated by iontophoresis of muscimol (a GABA_A agonist), then the adjacent barrel selectively loses its representation of that whisker (Fox et al., 2003) (Fig. 3D). Second, if many barrels are inactivated simultaneously by surface diffusion of muscimol through the cortex (this leads to no response to stimulation at all) and then the neuron is locally reactivated within a "bubble" of iontophoresed bicuculline (a GABA_A antagonist), the locally disinhibited layer 4 neuron responds only to a single whisker, which is identical to its anatomically defined principal whisker (Fox et al., 2003) (Fig. 3E). Two conclusions can be drawn; first, that the SRF is generated by intracortical excitation from neighboring barrels. Second, given that the thalamic afferents are not inhibited by muscimol, but the cortical cells outside the bicuculline bubble are, that the thalamic input generates the CRF of the neuron.

The second point produces a conundrum, because it implies that there is no convergence of whisker information from surrounding whiskers at the thalamocortical level. How can this be the case if

individual thalamic neurons respond to more than one whisker? The likely explanation is that the SRF components of thalamic neurons generate slower and more disparately distributed latencies compared to their central principal whisker component (Armstrong-James and Callahan, 1991). This means that if the cortical layer 4 neurons are predisposed to respond to only the most synchronized input from the thalamus, they will respond to the principal whisker rather than the surround. In the visual system, modeling studies emphasize the importance of synchrony in thalamic input for evoking a response in cortex (Wang et al., 2010). Given that the EPSPs generated by an individual thalamic neuron on a cortical cell are small, one would expect that significant spatial and temporal summation would

indeed be required to initiate a response (Bruno and Sakmann, 2006) and this is only available from the principal whisker input (Armstrong-James and Callahan, 1991). It is worth bearing in mind that a single whisker receptive field can be generated in the absence of local inhibition in the experimental condition described above (Fox et al., 2003). However, in the non-experimental condition, inhibition also acts to prevent any extraneous short-latency SRF input driving the cells because layer 4 inhibitory cells have large receptive fields (Swadlow and Gusev, 2002).

Layer 5

Although the layer 5 neurons can be driven by direct thalamic input (Armstrong-James and Fox, 1987; Armstrong-James et al., 1992) due to collaterals of the thalamic axons coursing radially through the cortex *en route* to layer 4 (White, 1978; White and Hersch, 1982), layer 5A and 5B neurons do not show as clear a center/SRF structure as layer 4 cells (Wright and Fox, 2010) (see Fig. 2B). Nevertheless, the principal whisker does evoke a shorter latency response in layer 5 cells than do the other whiskers, even though the principal whisker may not evoke the largest response (Wright and Fox, 2010). This effect is present in all four subdivisions of layer 5 (5A, 5B, septal, barrel), but most prominent for layer 5B barrel neurons and least prominent for layer 5B septal located neurons. Consequently, response latency is most often a better predictor of the principal barrel in which the neuron resides than is the magnitude of response.

The origin of the center and SRF components in layer 5 are strongly dependent on whether the cell lies in a barrel column or a septal column and whether it lies in layer 5A versus layer 5B. Using the same method described above for layer 4 cells (Fig. 3E), the thalamic component of the receptive field can be revealed if the cortex is silenced over a large area using muscimol and locally reactivated with bicuculline. The two most different outcomes are those shown by layer 5B barrel-

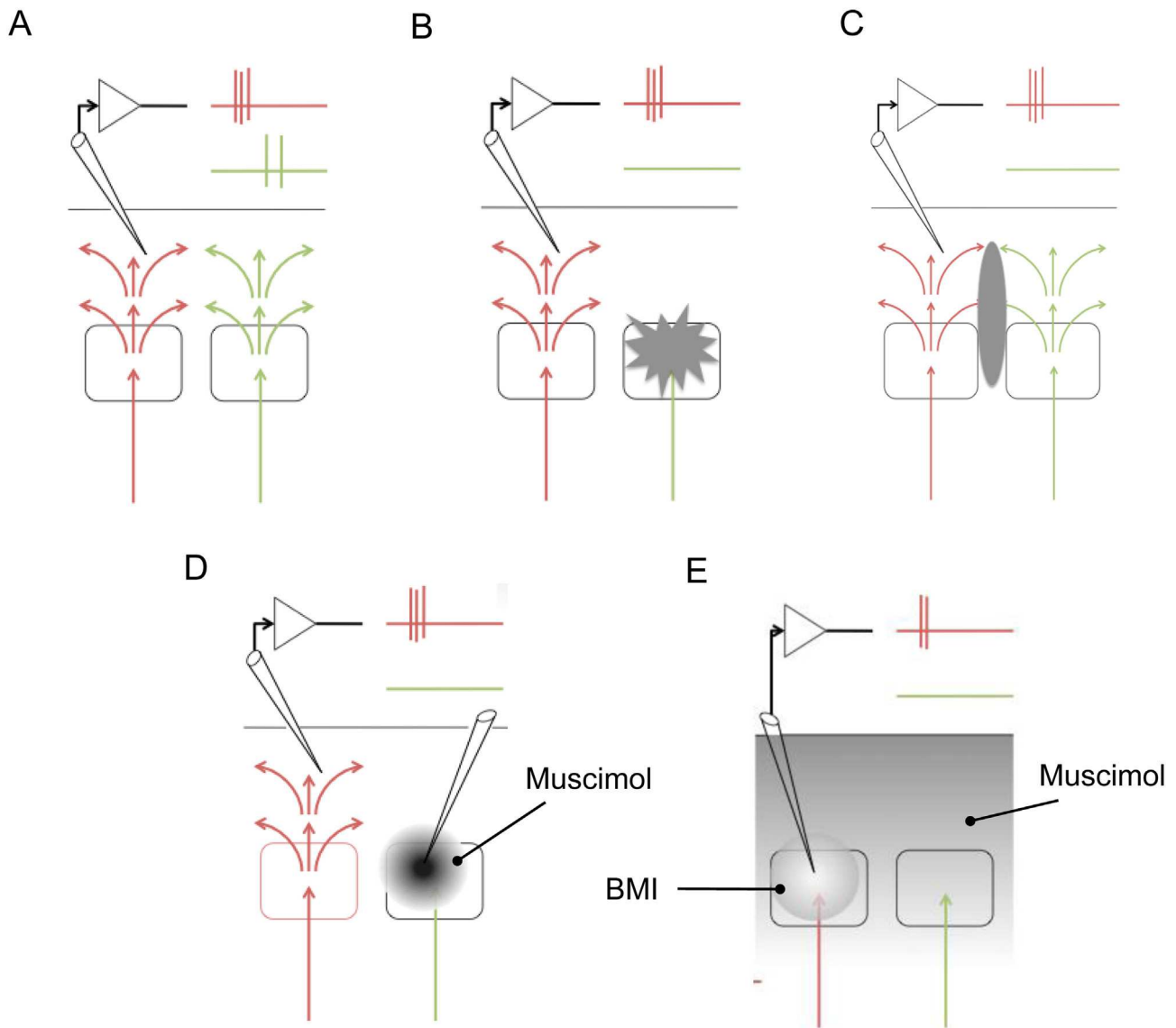

Fig. 3. Origins of center and surround receptive field components. (A) Excitation from the thalamus drives radial excitation within the column (shown as superficially directed for simplicity). The diagram depicts spike recordings for stimulating the PW corresponding to the red barrel-column (left: in which the electrode is located) and the PW corresponding to the green barrel-column (right). The PW spike response (shown as a red time–voltage recording trace) is of shorter latency than the smaller magnitude and longer latency spike response evoked by stimulating the surround whisker (green recording trace). (B) Ablating the barrel corresponding to the neighboring whisker selectively abolishes that whisker's responses in the neighboring barrel (Armstrong-James et al., 1992; Fox, 1994). (C) A row of lesions between neighboring barrel-columns also abolishes the surround whisker response in the neighboring barrel (Fox, 1994). (D) Iontophoresis of the GABA agonist muscimol reversibly excises the green whisker response from the neighboring barrel (Fox et al., 2003). (E) Cortical blockade with muscimol prevents intracortical transmission. Local reactivation in the barrel corresponding to the red whiskers input by iontophoresis of bicuculline methiodide (BMI), recovers a single PW receptive field and no surround receptive field (Fox et al., 2003).

column cells and layer 5A septal-column located cells (see Wright and Fox (2010) for the other two combinations). Layer 5B barrel-column cells behave very similarly to layer 4 cells; following reactivation in silenced cortex, almost all layer 5B cells exhibit single whisker receptive fields (Wright and Fox, 2010). This implies that layer 5B barrel-column cells have thalamic CRFs and all their SRFs inputs, of which there can be many (typically 8), are relayed intracortically (Fig. 4A). In contrast, layer 5A septal located cells behave differently and several whisker inputs re-emerge following global cortical inhibition and local reactivation with bicuculline even though the

other barrels in the cortex are silent. Several whiskers therefore comprise the CRF of a septal-column layer 5A cell (Fig. 4B) and, in some cases, most of the receptive field (up to 5 whiskers, Wright and Fox (2010)). The most likely explanation for these findings is that layer 5B cells mainly receive their thalamic input from VPM whereas the thalamic nucleus POM, which contains cells with larger receptive fields, projects to both septal locations and layer 5A (Diamond et al., 1992; Lu and Lin, 1993; Bureau et al., 2006).

In addition to the thalamic effect on the CRF of layer 5 cells, layer 2/3 also appears to exert an influence. Layer

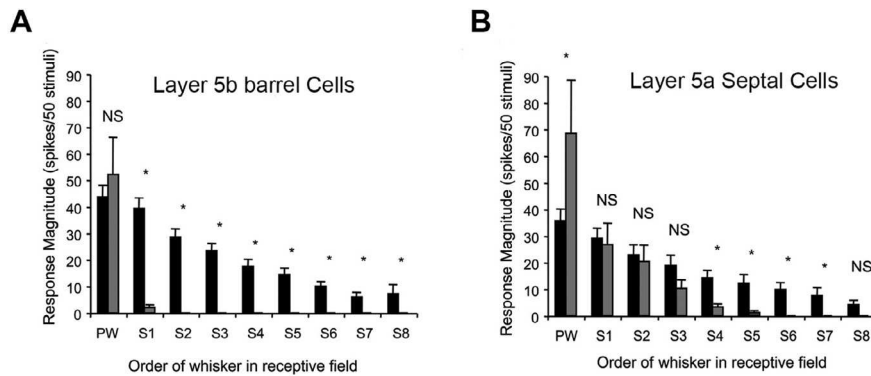

Fig. 4. Dependence of layer 5 neurons surround receptive field responses on intracortical inputs. (A) Barrel located layer 5B cells have single whisker receptive fields when intracortical connections are blocked with muscimol suggesting most surround responses are generated intracortically. The black bars represent the control condition without any activity blockade. Muscimol abolishes all whisker responses (condition not shown). The gray bars represent the whisker responses during global cortical activity blockade with muscimol and local reactivation with bicuculline. (B) Septal located layer 5A cells have multi-whisker receptive fields when intracortical connections are blocked (gray bars). Some whiskers are reactivated locally (S1–S3) others are not (S4–S8) suggesting some input from thalamus and some from cortex (NS = not significant, * $p < 0.05$; data from Wright and Fox, 2010).

2/3 is known to project strongly to layer 5 and is a conserved pathway throughout a number of cortical areas (Hooks et al., 2011). Recordings from layer 5 cells *in vitro*, show strong responses to input to stimulation of layer 2/3 cells with glutamate uncaging, particularly within the same barrel-column (Jacob et al., 2012). It has been shown that direct inhibition of layer 2/3 with muscimol causes a loss of CRF response in layer 5B cells (septal and barrel combined) (Wright and Fox, 2010). It is not clear at present whether the layer 2/3 response to principal whisker stimulation can be relayed to layer 5 fast enough to account for some of the very early components of the response to principal whisker stimulation in that layer (i.e. those below 10 ms), which suggests that the layer 2/3 excitatory input to layer 5 is more likely to act by sustaining the responses of layer 5 cells. Layer 5 intrinsic bursting (IB) cells, (which are a subset of layer 5 cells with intrinsic membrane properties leading to bursts of spikes – *vide infra*), exhibit EPSPs lasting more than 50 ms after the stimulus onset and can produce action potentials 30–40 ms after the stimulus onset (Jacob et al., 2017). Layer 2/3 cells therefore respond to principal whisker stimulation in sufficient time to influence the output of layer 5 IB cells. Layer 5 IB cells are known to be present in both layer 5A and 5B (Jacob et al., 2012) and their distribution is not known to differ between septal and barrel column locations.

INTERCOLUMNAR AND INTRACOLUMNAR PROCESSING

Signaling between columns

If the functional anatomy concerning the origin of the CRF is now put together with the latency of response information, it can be seen that principal whisker input arrives simultaneously in layer 5B and layer 4 before being relayed rapidly (within 2–4 ms) radially within the

column to activate layer 2/3 neurons (Armstrong-James et al., 1992). The subsequent relay of information horizontally to neighboring barrels over the next 50 ms or so generates the SRF of cells in those neighboring barrel-columns. Layer 5A responds relatively late compared to the rest of the barrel column, perhaps due to the longer latency input of P0m neurons or slower transmission within the cortical column, which is consistent with its CRF being mainly derived from P0m rather than VPm (Armstrong-James et al., 1992). But for most cells in barrel columns, the longer latency SRF input is derived from intracortical connections, which allows for integration of multi-whisker information within the cortex (Fig. 3).

If an object moves across the whiskers, or the whiskers move across an object, the corresponding barrels will be activated in a

particular sequence related to the timing of whisker activation and will evoke facilitatory and inhibitory effects between the cortical columns. The exact timing and therefore the exact sweep speed will affect the outcome. Layer 2/3 has the highest proportion of cells in the cortex exhibiting facilitatory responses to neighboring whisker stimulation (Shimegi et al., 1999). It takes a few milliseconds longer for a signal to travel to layer 2/3 within its own column (1–2.5 ms to the near side and 9–15 ms to the far side) (Armstrong-James et al., 1992). If an EPSP duration of approximately 10 ms is considered this gives a range for integration of adjacent whisker activity from 1 to 25 ms. The modal whisker pairing interval for layer 2/3 cells is 1 ms but examples of facilitation can occur at intervals of around 10–14 ms (Shimegi et al., 1999), which fits well with the timing of signal flow between the barrels. The facilitatory effects are seen in layer 2/3 at the borders of the barrels (Shimegi et al., 2000) and indeed when imaging methods are used an annulus of correlation sensitive cells can be seen around the edge of the barrels above the septa (Estebanez et al., 2016).

Shimegi et al. (1999) also demonstrated the direction selectivity of the coincidence detection mechanism where rostral whiskers stimulation can facilitate responses from the neighboring caudal whisker but not *vice versa*. A similar finding has been reported using imaging methods where the animal performs the scan in a rostra-caudal direction by whisking (Pluta et al., 2017). More generally, correlation detection of multi whisker input in this way allows for signaling the direction of motion of a virtual bar across the entire caudal whisker pad in any direction (Jacob et al., 2008). Furthermore, multiwhisker interactions are necessary for creating a map in layer 2/3 not of the whiskers, but of the position of an object in scanned space (Pluta et al., 2017). Multi whisker interactions are

necessary for this property in layer 2/3 and it is plausible that they depend on directional neighboring whisker facilitation.

The SRFs of cells in the extra granular layers of the cortex are highly plastic, which implies that the pathways between cortical columns are highly plastic (Fox, 1994). While information is to some extent segregated within individual barrel-columns, the synaptic connections between barrels-column allow information from different whiskers to be integrated across the barrel field (Wallace and Fox, 1999). It is possible that inter-barrel connections enable the cortex to encode particular combinations of whisker activation during exploration, which might be unique for particular objects or types of object. Given that these connections are plastic, they could form a substrate for adapting the relative weights of connections to improve discrimination and/or detection of objects. In this sense, one function of the input-column is to initially segregate information from individual whiskers during the first few milliseconds of processing, so that it can then be summed in different combinations in neighboring columns with different synaptic weighting to improve discriminations of learned or novel objects. Given the importance of the timing of multi whisker interactions to create facilitation and of multi-whisker responses *per se* for creating layer 2/3 maps of objects in scanned space, it is particularly interesting that the latency of responses to neighboring whiskers decreases with chessboard deprivation (where every other whisker is removed). Whisker deprivation results in speeding up responses on the near side of the neighboring barrel to spared whisker stimulation by 1.5–2 ms and far side of the neighboring barrel by 4.5–6.5 ms (Wallace and Fox, 1999). In this way, neighboring whiskers in a chessboard deprived mouse (for example D1 and D3) produce similar latencies of interaction in the intervening barrel (D2) as the neighboring whiskers in a normal whiskered mouse (D1 and D2).

Information processing within the column

As described above, the excitatory signal flow through the cortex can be determined from the responses of individual neurons having first discarded the background noise or spontaneous activity. A different but complementary way of describing the signal flow through the cortical structure is to consider the information present about the stimulus at each point in the column. Chernoff information characterizes discriminability between two probability distributions (Cover and Thomas, 2006). If the two distributions are the evoked response $f(t)$ and a baseline firing rate trace $g(t)$, the Chernoff information (maximum of I) is given by:

$$I \simeq \max_{\alpha} \left\{ -\sum_t \log \left[(f(t)\Delta)^{\alpha} (g(t)\Delta)^{1-\alpha} + (1-f(t)\Delta)^{\alpha} (1-g(t)\Delta)^{1-\alpha} \right] \right\}$$

$$\simeq \max_{\alpha} \sum_t \Delta [\alpha f(t) + (1-\alpha)g(t) - f^{\alpha}(t)g^{1-\alpha}(t)]$$

where Δ is a small interval of time and α is a sensitivity value varied between 0 and 1 to identify the maximum value of I . This quantity (I) gives an upper boundary to

the accuracy of an optimal decoder in discriminating whether the observed spikes are generated from: $f(t)$ or $g(t)$. If the difference between firing rate traces $f(t)$ and $g(t)$ is small, the Chernoff information becomes equivalent to the Fisher information, a measure widely used in neuroscience to quantify detectability of a small parameter change (Seung and Sompolinsky, 1993; Toyozumi et al., 2006), but the Chernoff information is more general than the Fisher information because it can also characterize large “distances” between the two distributions [for further information on the use of Chernoff information in Neuroscience, see (Kang et al., 2004)].

Information about the stimulus can be determined during the time evolution of the neuronal response by considering the Chernoff information in short intervals (1-ms bins) and integrating the information with time (Jacob et al., 2017). By this measure, the greatest information about the principal whisker is present in layer 4 neurons, closely followed by the layer 2/3 neurons and lower values are present for the layer 5 neurons (Jacob et al., 2017). This broadly follows the canonical view of information processing within the cortical columns of the visual cortex from layer 4 to layer 3 to layer 5 as envisaged by Gilbert and Wiesel (1983) and discussed by Douglas and Martin (2004). It differs slightly from the flow arrived at by latency (*vide supra*) in that layer 5B has a short-latency response component (Armstrong-James et al., 1992) that short-circuits the supra-granular route. A similar conclusion about information flow for the principal whisker is reached if an alternative measure of information is employed. The receiver operating characteristic (ROC) of a system measures its performance in discriminating two conditions over a range of discrimination thresholds. In this case the two conditions are stimulus versus no stimulus. Using this method, layer 2/3 and layer 4 cells show almost identical ROC followed by lower values in layer 5 (Jacob et al., 2017). As discussed in the following sections, the information content in layer 5 neurons can be further subdivided by neuron type and can also be modified under conditions that induce experience-dependent plasticity, which change the relative information content in supra- and infragranular cortex.

BARREL CORTEX OUTPUT STREAMS

Subcortical and corticocortical projections

The preceding sections have described the inputs to the barrel cortex and how the signal propagates within the cortical columns and between the cortical columns. This approach provides a first-order approximation for cortical columnar function using a simple stimulus applied to a single whisker at a time, but is remarkably predictive of what happens during multi whisker stimulation. The function of the column becomes increasingly more complicated once the multiple outputs of the column are taken into consideration (i.e. the outputs other than those to neighboring columns). SI corticofugal projections arise from several points in the column including layer 6 projections to VPM (Chmielowska et al., 1989) and layer 3 projections to

MI, and SII (Chakrabarti and Alloway, 2006). However, this section concentrates on the layer 5 projections.

The neurons that give rise to subcortical and corticocortical projections show a good correlation with their intrinsic membrane properties. In particular, two sub-types of layer 5 cell known as regular spiking cells (RS) and intrinsic bursting cells (IB) have markedly different projection patterns. The two can be distinguished electrophysiologically and morphologically. Somatic current injection produces a regular train of spikes in RS cells and a burst of spikes in IB cells (Connors et al., 1982; Connors and Gutnick, 1990). The RS cells have a distinctly different neuronal morphology from the IB cells in that they have simple relatively unbranched apical dendrites and are smaller overall than the IB cells, which have larger more complex branching apical dendrites and larger somata (Chagnac-Amitai et al., 1990; Jacob et al., 2012; Staiger et al., 2016). Studies in rat cortical slices with uncaged glutamate have shown that RS cells receive most excitatory connections within the column and receive inhibitory connections from both within the column and layer 5 of the neighboring columns (Schubert et al., 2001). IB cells have similar connections except that they receive more excitatory input from neighboring columns, a stronger overall input from layer 6 within and outside the column and also tend to have far weaker inhibitory connections than RS cells (Schubert et al., 2001). Within SI cortex, the morphological correlate of the layer 5 RS cells (slender tufted cells) project more strongly to supragranular layers than IB cells (thick tufted cells) (Narayanan et al., 2015). Outside SI cortex, the RS cells project to other cortical areas whereas the IB cells project sub cortically (Gao and Zheng, 2004; Hattox and Nelson, 2007; Le Be et al., 2007). To a first order approximation then, the RS and IB properties of the cells can be used to distinguish between corticocortical and subcortical projecting cells.

In the studies described below, data on RS and IB cells have been partly acquired in the rat and partly in the mouse barrel cortex. Discoveries in the two species are largely comparable, but the molecular mechanisms underlying plasticity have only been studied in the mouse. RS and IB cells were found in both layer 5A and 5B and a higher proportion of IB cells in were found in layer 5B than in layer 5A. In general, septal and barrel locations were not distinguished for RS and IB cells for the studies described below.

Plasticity mechanisms in RS and IB cells

A further distinction between IB and RS cell properties becomes apparent if plasticity is induced in the barrel cortex by whisker trimming. Depriving a single row of whiskers in the rat creates a row of cortical columns lacking their principal whisker input, but retaining their SRF input from the neighboring flanks of whiskers (Jacob et al., 2012, 2017). Row-deprivation for several days leads to plasticity in layer 5 cells which can be tested by glueing back the trimmed whiskers on the day of the experiment and comparing responses to spared and deprived inputs. Under these conditions, in the rat barrel cortex, the RS cells show a strong depression in their

response to the deprived principal whisker input and a minor potentiated response to the surround flanking row whiskers at short-latency. In contrast, the IB cells show a weak depression to the deprived principal whisker inputs and a strong potentiation of surround whisker responses. Similarly, in ex vivo slices from row deprived mouse cortex, glutamate uncaging shows marked depression of barrel-column inputs for RS cells but not IB cells located in layer 5B, while an increase in excitatory input from neighboring barrels is observed for layer 5B IB cells but not layer 5B RS cells. These ex vivo findings both corroborate the *in vivo* findings and confirm that the origin of the SRF components for the IB cells are indeed intracortical (see Section “Input signal processing” on input signal processing above). The plasticity seen in RS and IB cells is an unusual separation of depression and potentiation processes, which elsewhere in the cortex have been observed to be present in the same neurons (Mioche and Singer, 1989; Hardingham et al., 2008).

The mechanisms underlying RS and IB neuron plasticity have been elucidated in mouse barrel cortex, again using row-deprivation (Greenhill et al., 2015). RS cells show slower depression of the deprived whisker response than IB cells that eventually recovers back to baseline after approximately 10 days in the mouse, but in the rat does not completely recover within this time period (Jacob et al., 2017). The depression and recovery of principal whisker responses in RS and IB cells is mirrored by a decrease and recovery in miniature excitatory post-synaptic potentials (mEPSP) amplitude over the same time course. This implies that the changes in responsiveness can be explained by changes in excitatory connections onto RS and IB cells (Greenhill et al., 2015).

Studies in tumor necrosis factor alpha (TNF α) knockout mice have shown that homeostatic plasticity depends on TNF α . A particular form of homeostatic plasticity known as synaptic scaling requires TNF α production from glial cells (Stellwagen and Malenka, 2006). Studies in the visual system have shown that part of the visual cortical response to monocular deprivation involves an initial depression of the closed eye response followed by a partial TNF α -dependent homeostatic recovery of the closed eye response (Kaneko et al., 2008). In the barrel cortex, the depression and homeostatic recovery of the RS neurons' response to the deprived whiskers is also TNF α -dependent (Greenhill et al., 2015).

The TNF α mechanism is distinct from the Hebbian form of potentiation exemplified by LTP. LTP can be induced in TNF α knockouts (Kaneko et al., 2008). Both LTP and experience-dependent potentiation in layer 2/3 of the barrel cortex are dependent instead on CaMKII and more specifically on CaMKII autophosphorylation (Hardingham et al., 2003). If homeostatic plasticity is studied in the CaMKII-t286a mouse (which lacks CaMKII autophosphorylation and hence lacks LTP), layer 5 RS cells show a normal homeostatic recovery of response, which demonstrates that TNF α -dependent homeostatic plasticity does not require LTP mechanisms (Greenhill et al., 2015).

Layer 5 IB cells not only show faster recovery of deprived principal whisker input, but they also show

clear potentiation of surround whisker input in both the rat (Jacob et al., 2012, 2017) and in the mouse (Greenhill et al., 2015). This contrasts with RS cells that only show a return back to baseline evoked response levels rather than potentiation beyond baseline. In IB cells, potentiation of the spare SRF response above baseline is again mirrored in the potentiation above baseline of the mEPSP (Greenhill et al., 2015; Glazewski et al., 2017). In this case, the potentiation is both $TNF\alpha$ and CaMKII-dependent, drawing a further distinction between plasticity mechanisms in RS and IB cells.

Information processing in RS and IB cells

Within the cortical column, principal whisker information decreases significantly following whisker deprivation in layer 2/3 and layer 5 RS cells compared with responses in undeprived animals (Jacob et al., 2017). However, the spared whisker input, which is generated through intracortical connectivity for barrel-column cells (see above), increases in layer 5 IB and RS cells, again relative to the levels seen in undeprived animals. As discussed above, the increase in Chernoff information in the IB cells' spared whisker response can partly be explained by Hebbian and partly by homeostatic potentiation of the input, and occurs despite a recovery in the IB cells' spontaneous activity. However, the increase in spared whisker information in RS cells is even greater than that in IB cells (Jacob et al., 2017). For RS cells, not only does a short-latency component of the receptive field potentiate, due to an increase in excitatory conductance (Jacob et al., 2017), but the background spontaneous activity decreases significantly as well (Glazewski et al., 2017; Jacob et al., 2017). Because information measures take into account both the response and the background firing rate, the increase in information content for layer 5 RS cells is particularly pronounced due to the combined signal increase and background decrease.

Even though the two types of layer 5 cells (RS and IB) use different mechanisms to achieve it, they both increase the information available about the spared whiskers at the output level of the cortex: IB cells by Hebbian and homeostatic potentiation and RS cells by decreasing spontaneous activity and homeostatic potentiation. The layer 5 cells of the cortex adapt to maximize the information available to the rest of the system about the inputs that are present. The level of adaptation may seem unusually large, but this is partly a function of the experimental paradigm where the effect needs to be as large as possible in order to measure it accurately. However, the results show that the cortex is capable of these forms of plasticity. It is therefore conceivable that this plasticity mechanism is employed on a finer scale by the cortex to continually make fine adjustments to the outputs in order to regulate the relative importance or signal-to-noise ratio of information from different whisker sources in the barrel cortex.

What could the differences in plasticity tell us about the types of information carried in these different output streams, one to subcortical locations (IB cells) and the other to cortical locations (RS cells)? It is possible that the subcortical targets of the IB cells simply require

higher levels of ambient activity in order to maintain their target cells close to threshold. Alternatively, by increasing the background level of spontaneous activity, the dynamic range of encoded information can be increased provided that increases and decreases in firing rate can convey the signal. The high background spontaneous activity of IB cells (13 Hz in rats and 5 Hz in mice), their intrinsic burst firing mode and the higher number of spikes evoked by sensory input suits them for coding information by spike number or spike rate (Jacob et al., 2012, 2017; Glazewski et al., 2017). Conversely, the RS cells are under far tighter inhibitory control than the IB cells, including from neighboring barrels (Schubert et al., 2001) and have lower spontaneous firing rates (8 Hz in rats and 2.5 Hz in mice) measured under the same conditions as mentioned above for IB cells (intracellular recording and urethane anesthesia) (Glazewski et al., 2017; Jacob et al., 2017). When RS cells undergo plasticity, they increase the fidelity of the spike timing of their responses rather than the number of spikes they produce (Jacob et al., 2012). The mechanisms for this is an increase in short-latency excitatory conductance (Jacob et al., 2017), likely to originate from the VPM thalamocortical input (White and Hersch, 1982; Agmon and Connors, 1991). This suggests that RS cells may code information by spike timing more than spike rate and conceivably by correlation of spike input for groups of RS cells projecting to other cortical areas. These considerations raise further questions about the projection targets of RS and IB cells and what types of information their targets are predisposed to receive.

Corticocortical projections: dorsal and ventral streams

The distinction between RS and IB cells is only an approximation of the diversity of layer 5 projection cells in the barrel cortex. RS cells give rise to many different corticocortical pathways. In primate cortex, corticocortical pathways emanating from somatosensory cortex are classically described as belonging to one of two functional streams known as dorsal and ventral (Gardner, 2008). The dorsal stream is involved in motor planning, exploration, decision making and strategy switching while the ventral stream is involved in object recognition, multimodal integration and memory. As described below, the somatosensory system of rodents exhibit homologous cortical areas and connectivity to the primate, suggesting that dorsal and ventral streams might be present in mice and rats. Certainly, evidence has been presented for the existence of dorsal and ventral streams in the rodent visual system (Wang et al., 2012) and while it is beyond the scope of the present article to make the complete case for the existence of dorsal and ventral streams in the rodent somatosensory system here, some of the evidence is summarized below.

Ventral stream. The rodent cortical areas that might be considered homologous to primate ventral stream cortical areas include SII, parietal ventral (PV) and parietal rhinal cortex (PR). Anatomical evidence suggests that these cortical structures are highly

interconnected. SI projects to SII, PV and PR (Krubitzer et al., 1986; Fabri and Burton, 1991; Aronoff et al., 2010). The projections from SI to SII and PV are somatotopic, while those to PR are not (Krubitzer et al., 1986; Fabri and Burton, 1991). SI and SII are considered to sit at similar levels of cortical hierarchy and both project to PV and PR (Krubitzer et al., 1986). PR cortex projects to entorhinal cortex and hence somatosensory information can reach the hippocampus by this route (Miranda and Bekinschtein, 2017).

While SI and SII project to more ventral located cortical areas, it is not clear that information flows from lower to higher order areas exclusively within the stream. For example, ablation of SI and SII does not prevent somatosensory responses in PV (Rodgers et al., 2008), suggesting a thalamic source of input is also important (Shi and Cassell, 1998). Similarly, inactivation of S1 causes a partial (55%) loss of infraorbital nerve response in the hippocampus, suggesting SI is not the only cortical structure involved in transmission and indeed that parallel thalamic input to other cortical structures could be involved (Pereira et al., 2007).

Nevertheless, cortical areas more ventral in the stream appear to be involved in more integrative sensory processing than SI. SII is characterized by much larger receptive fields than SI and lacks clear principal whisker organization (Kwegyir-Aful and Keller, 2004), while PV integrates tactile and auditory stimuli (Krubitzer et al., 1986; Nishimura et al., 2015). Destruction of ventral stream structures corresponding to PV and PR cortex (Krubitzer et al., 1986) causes deficits in perception of more complicated tactile stimuli (Ramos, 2014). As mentioned above, there is a route to the hippocampus from ventral stream structures and hippocampal neurons can respond to texture identity and hold texture location information during a discrimination/reward task (Itskov et al., 2011). PR is involved in object recognition (Barker et al., 2007) and well positioned to make the assessment as it receives sensory information from SI and SII as well as mnemonic information back from the hippocampus mainly via the entorhinal cortex (Insausti et al., 1997). In general then, the ventral stream areas appear to be involved in processing tactile information for haptic memory (Itskov et al., 2011; Diamond and Arabzadeh, 2013).

Dorsal stream. The rodent cortical areas that might be considered homologous to primate dorsal stream structures include primary motor cortex (MI) also known as agranular lateral, secondary motor cortex (MII) also known as agranular medial cortex, prefrontal cortex (PFC) and posterior parietal cortex (PPC). SI is known to project to MI and MII (Fabri and Burton, 1991; Chakrabarti and Alloway, 2006), and the whisker system specifically to the junction between medial and lateral granular cortex, while PPC projects to MII (Wang et al., 2012; Smith and Alloway, 2013). In addition, SI, MI and MII all project to PFC (Bedwell et al., 2014).

Cortical areas more dorsal in the stream appear to be involved in progressively more complicated decision processes leading to goal directed movement.

Movements can be evoked by stimulation of MI and the movement zones are topographically organized (Wise and Donoghue, 1986; Sanes et al., 1988; Smith and Alloway, 2013). MII also contains a second forelimb representation in addition to the one located in MI. Electrode recordings show that MII can encode decision and choice information and that lesioning MII produces behavior that does not react to updated reward contingencies (Sul et al., 2011). In general, MII appears to integrate internal state with movement to produce goal directed behavior (Saiki et al., 2014). Inactivation of MII can also cause delays to initiating an action suggesting it is involved in preparation of movement and in this sense similar in function to primate premotor cortex (Smith et al., 2010). The PFC is involved in switching strategy to new behaviors (Ragozzino et al., 1999) and learning under conditions of changed task contingencies (Kim and Ragozzino, 2005). Inactivation of mPFC impairs the animal's ability to shift its attention to newly relevant task information (Birrell and Brown, 2000).

The PPC has features in common with the ventral stream in that it integrates multimodal information. However, it projects to MII and it has been estimated that 84% of its projections are to dorsal rather than ventral stream areas (Wang et al., 2012). Ablation of the PPC leads to hemilateral neglect, most likely because the neurons in this structure encode information about head direction and object location and their conjunction (Wilber et al., 2014). By projecting this information rostrally in the dorsal stream, PPC provides motor areas with information about the location of objects that might be movement targets.

Septal and barrel projections within dorsal and ventral streams. There is some anatomical and physiological evidence that the dorsal and ventral streams arise from

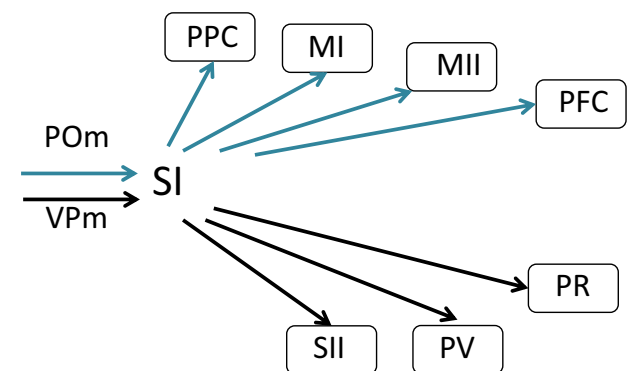

Fig. 5. Ipsilateral cortico-cortical connections of somatosensory cortex. The somatosensory cortex distributes information to many other cortical areas, here grouped into two putative streams analogous to the dorsal and ventral streams of primate cortex. The stream comprising motor cortex (M1), secondary motor cortex (MII) and prefrontal cortex (PFC) is involved in motor planning and coordination (top, blue arrows). The stream comprising the secondary somatosensory (SII), parietal ventral (PV), parietal lateral (PL) and parietal rhinal (PR) is viewed as being composed of largely sensory areas that provide a route to the hippocampus for tactile memory. Inputs to S1 are derived from ventral posteromedial nucleus (VPM) and the Posterior Medial nucleus of the thalamus (POM), which also have a relationship to the ventral and dorsal streams respectively (Blue: dorsal stream, Black: ventral stream).

separate channels of information within the barrel cortex. For example, Alloway has presented evidence for different septal and barrel column projection streams (Chakrabarti and Alloway, 2006; Alloway, 2008; Chakrabarti et al., 2008). Septal columns receiving information from thalamic P_{Om} project to MI, while barrel-columns receiving information from thalamic V_{Pm} project to SII, which also receives connections from septal columns (Alloway, 2008). These findings help to explain why barrel cortex neurons projecting to MI compared to SII have been found to code different types of information and to show different adaptation in response to texture discrimination (Chen et al., 2013, 2015). These studies therefore suggest some congruity between the septal and barrel columns within the barrel cortex and the dorsal and ventral streams within the cortex (Fig. 5).

Subcortical projections

The studies described above show the diversity of cortical projection targets and emphasize that the RS subdivision only provides a rough categorization of layer 5 output cells. Similarly, the separation of one class of layer 5 cells into an IB population is again only an approximation of the diversity of the sub-types of projection neuron. IB cells project subcortically to thalamus, brainstem, superior colliculus, striatum, zona incerta, the pretectal nucleus and pons. The strongest projections are those to striatum, SII, MI and thalamus when assessed by overall fluorescence of axons in the terminal region, though these also tend to be the largest target structures (Mao et al., 2011).

Studies using multiple simultaneous intracellular recordings have demonstrated that the projection targets of layer 5 neurons are closely related to the intracortical connections they receive (Brown and Hestrin, 2009). Similarly, the intrinsic firing properties of layer 5 projection neurons which, as detailed above, are related to their projection targets, are also closely related to their intracortical connectivity (Otsuka and Kawaguchi, 2008). These findings together with those on RS and IB cell plasticity and connectivity (Schubert et al., 2001; Greenhill et al., 2015) demonstrate that sub-circuits exist within the overall framework of the cortical column (Fig. 1D), such that projections to different types of sub-cortical target receive information from different combinations of input within the column and between columns. In this regard, it is particularly noticeable that IB cells receive greater excitatory drive from neighboring columns and less inhibitory control from neighboring columns than RS cells (Schubert et al., 2001), which is consistent with layer 5B neurons (which have a larger proportion of IB cells (Jacob et al., 2012)), receiving multi whisker information from intracortical connections (Wright and Fox, 2010).

CONCLUDING REMARKS

Consideration of the inputs and outputs of layer 5 RS and IB cells emphasizes the differences between the two cell types. However, it seems unlikely that the subcortical projections and the corticocortical projections act as independent systems. Indeed, as an example of the

contrary, the septal-column system organizes corticocortical output to MI, and subcortical output to basal pons and contralateral striatum (Alloway, 2008). Similarly, while the ventral stream may project output to cortical structures important for analyzing and recognizing objects, barrel cortex also projects back to subcortical sensory nuclei such as V_{Pm} and the brainstem trigeminal nuclei. Therefore, despite the level of specialization discovered in the intracortical connections and plasticity mechanisms of RS and IB cells, it is likely that they act cooperatively within homotypic systems of cortical and subcortical structures. The problem with which the experimenter is presented, is that understanding the function of a cortical column involves identifying and unpicking the sub-circuits that exist within the envelope of the input column before reassembling the pieces into functioning sub-systems. This issue presents a major challenge for the field. However, the large volume of work already conducted on the barrel cortex and the anatomical advantage of at least being able to visualize the input column means that barrel cortex is still likely to provide a good model to tackle this question.

*Acknowledgments—*I am most grateful to funding from the MRC and NIH for the author's work discussed in this review. I would also like to thank Kevin Alloway, Jared Smith, Shubo Chakrabarti and Matthew Diamond for discussions on cortical projection pathways and to thank Stuart Greenhill and Vincent Jacob for critical comments on the text.

REFERENCES

- Agmon A, Connors BW (1991) Thalamocortical responses of mouse somatosensory (barrel) cortex in vitro. *Neuroscience* 41:365–379.
- Alloway KD (2008) Information processing streams in rodent barrel cortex: the differential functions of barrel and septal circuits. *Cereb Cortex* 18:979–989.
- Armstrong-James M, Callahan CA (1991) Thalamo-cortical processing of vibrissal information in the rat. II. spatiotemporal convergence in the thalamic ventroposterior medial nucleus (V_{Pm}) and its relevance to generation of receptive fields of S1 cortical "barrel" neurones. *J Comp Neurol* 303:211–224.
- Armstrong-James M, Fox K (1987) Spatiotemporal convergence and divergence in the rat S1 "barrel" cortex. *J Comp Neurol* 263:265–281.
- Armstrong-James M, Fox K, Das-Gupta A (1992) Flow of excitation within rat barrel cortex on striking a single vibrissa. *J Neurophysiol* 68:1345–1358.
- Aronoff R, Matyas F, Mateo C, Ciron C, Schneider B, Petersen CC (2010) Long-range connectivity of mouse primary somatosensory barrel cortex. *Eur J Neurosci* 31:2221–2233.
- Barker GR, Bird F, Alexander V, Warburton EC (2007) Recognition memory for objects, place, and temporal order: a disconnection analysis of the role of the medial prefrontal cortex and perirhinal cortex. *J Neurosci* 27:2948–2957.
- Bedwell SA, Billeet EE, Crofts JJ, Tinsley CJ (2014) The topology of connections between rat prefrontal, motor and sensory cortices. *Front Syst Neurosci* 8:177.
- Birrell JM, Brown VJ (2000) Medial frontal cortex mediates perceptual attentional set shifting in the rat. *J Neurosci* 20:4320–4324.
- Brown SP, Hestrin S (2009) Intracortical circuits of pyramidal neurons reflect their long-range axonal targets. *Nature* 457:1133–1136.
- Bruno RM, Sakmann B (2006) Cortex is driven by weak but synchronously active thalamocortical synapses. *Science* 312:1622–1627.

- Bruno RM, Simons DJ (2002) Feedforward mechanisms of excitatory and inhibitory cortical receptive fields. *J Neurosci* 22:10966–10975.
- Bureau I, von Saint Paul F, Svoboda K (2006) Interdigitated paleoniscal and lemniscal pathways in the mouse barrel cortex. *PLoS Biol* 4:e382.
- Chagnac-Amitai Y, Luhmann HJ, Prince DA (1990) Burst generating and regular spiking layer 5 pyramidal neurons of rat neocortex have different morphological features. *J Comp Neurol* 296:598–613.
- Chakrabarti S, Alloway KD (2006) Differential origin of projections from SI barrel cortex to the whisker representations in SII and MI. *J Comp Neurol* 498:624–636.
- Chakrabarti S, Zhang M, Alloway KD (2008) MI neuronal responses to peripheral whisker stimulation: relationship to neuronal activity in SI barrels and septa. *J Neurophysiol* 100:50–63.
- Chen JL, Carta S, Soldado-Magraner J, Schneider BL, Helmchen F (2013) Behaviour-dependent recruitment of long-range projection neurons in somatosensory cortex. *Nature* 499:336–340.
- Chen JL, Margolis DJ, Stankov A, Sumanovski LT, Schneider BL, Helmchen F (2015) Pathway-specific reorganization of projection neurons in somatosensory cortex during learning. *Nat Neurosci* 18:1101–1108.
- Chmielowska J, Carvell GE, Simons DJ (1989) Spatial organization of thalamocortical and corticothalamic projection systems in the rat Sml barrel cortex. *J Comp Neurol* 285:325–338.
- Connors BW, Gutnick MJ (1990) Intrinsic firing patterns of diverse neocortical neurons. *Trends Neurosci* 13:99–104.
- Connors BW, Gutnick MJ, Prince DA (1982) Electrophysiological properties of neocortical neurons in vitro. *J Neurophysiol* 48:1302–1320.
- Cover T, Thomas J (2006) Elements of information theory. Hoboken, New Jersey: Wiley.
- Diamond ME, Arabzadeh E (2013) Whisker sensory system – from receptor to decision. *Prog Neurobiol* 103:28–40.
- Diamond ME, Armstrong-James M, Budway MJ, Ebner FF (1992) Somatic sensory responses in the rostral sector of the posterior group (POm) and in the ventral posterior medial nucleus (VPM) of the rat thalamus: dependence on the barrel field cortex. *J Comp Neurol* 319:66–84.
- Douglas RJ, Martin KA (2004) Neuronal circuits of the neocortex. *Annu Rev Neurosci* 27:419–451.
- Ego-Stengel V, Le Cam J, Shulz DE (2012) Coding of apparent motion in the thalamic nucleus of the rat vibrissal somatosensory system. *J Neurosci* 32:3339–3351.
- Estebanez L, Bertherat J, Shulz DE, Bourdieu L, Leger JF (2016) A radial map of multi-whisker correlation selectivity in the rat barrel cortex. *Nat Commun* 7:13528.
- Fabri M, Burton H (1991) Ipsilateral cortical connections of primary somatic sensory cortex in rats. *J Comp Neurol* 311:405–424.
- Feldmeyer D, Lubke J, Silver RA, Sakmann B (2002) Synaptic connections between layer 4 spiny neurone-layer 2/3 pyramidal cell pairs in juvenile rat barrel cortex: physiology and anatomy of interlaminar signalling within a cortical column. *J Physiol* 538:803–822.
- Feldmeyer D, Roth A, Sakmann B (2005) Monosynaptic connections between pairs of spiny stellate cells in layer 4 and pyramidal cells in layer 5A indicate that lemniscal and paleoniscal afferent pathways converge in the infragranular somatosensory cortex. *J Neurosci* 25:3423–3431.
- Fox K (1994) The cortical component of experience-dependent synaptic plasticity in the rat barrel cortex. *J Neurosci* 14:7665–7679.
- Fox K, Wright N, Wallace H, Glazewski S (2003) The origin of cortical surround receptive fields studied in the barrel cortex. *J Neurosci* 23:8380–8391.
- Fujita I, Tanaka K, Ito M, Cheng K (1992) Columns for visual features of objects in monkey inferotemporal cortex. *Nature* 360:343–346.
- Gao WJ, Zheng ZH (2004) Target-specific differences in somatodendritic morphology of layer V pyramidal neurons in rat motor cortex. *J Comp Neurol* 476:174–185.
- Gardner EP (2008) Dorsal and ventral streams in the sense of touch. Academic Press.
- Gilbert CD, Wiesel TN (1983) Functional organization of the visual cortex. *Prog Brain Res* 58:209–218.
- Glazewski S, Greenhill S, Fox K (2017) Time-course and mechanisms of homeostatic plasticity in layers 2/3 and 5 of the barrel cortex. *Philos Trans R Soc Lond B Biol Sci* 372.
- Greenhill SD, Ranson A, Fox K (2015) Hebbian and homeostatic plasticity mechanisms in regular spiking and intrinsic bursting cells of cortical layer 5. *Neuron* 88:539–552.
- Hardingham N, Glazewski S, Pakhotin P, Mizuno K, Chapman PF, Giese KP, Fox K (2003) Neocortical long-term potentiation and experience-dependent synaptic plasticity require alpha-calmodulin/calmodulin-dependent protein kinase II autophosphorylation. *J Neurosci* 23(11):4428–4436.
- Hardingham N, Wright N, Dachtler J, Fox K (2008) Sensory deprivation unmasks a PKA-dependent synaptic plasticity mechanism that operates in parallel with CaMKII. *Neuron* 60:861–874.
- Hattox AM, Nelson SB (2007) Layer V neurons in mouse cortex projecting to different targets have distinct physiological properties. *J Neurophysiol* 98:3330–3340.
- Hooks BM, Hires SA, Zhang YX, Huber D, Petreanu L, Svoboda K, Shepherd GM (2011) Laminar analysis of excitatory local circuits in vibrissal motor and sensory cortical areas. *PLoS Biol* 9:e1000572.
- Hubel DH, Wiesel TN (1963) Shape and arrangement of columns in cat's striate cortex. *J Physiol* 165:559–568.
- Insausti R, Herrero MT, Witter MP (1997) Entorhinal cortex of the rat: cytoarchitectonic subdivisions and the origin and distribution of cortical efferents. *Hippocampus* 7:146–183.
- Itskov PM, Vinnik E, Diamond ME (2011) Hippocampal representation of touch-guided behavior in rats: persistent and independent traces of stimulus and reward location. *PLoS One* 6:e16462.
- Jacob V, Le Cam J, Ego-Stengel V, Shulz DE (2008) Emergent properties of tactile scenes selectively activate barrel cortex neurons. *Neuron* 60:1112–1125.
- Jacob V, Petreanu L, Wright N, Svoboda K, Fox K (2012) Regular spiking and intrinsic bursting pyramidal cells show orthogonal forms of experience-dependent plasticity in layer V of barrel cortex. *Neuron* 73:391–404.
- Jacob V, Mitani A, Toyozumi T, Fox K (2017) Whisker row deprivation affects the flow of sensory information through rat barrel cortex. *J Neurophysiol* 117:4–17.
- Kaneko M, Stellwagen D, Malenka RC, Stryker MP (2008) Tumor necrosis factor-alpha mediates one component of competitive, experience-dependent plasticity in developing visual cortex. *Neuron* 58:673–680.
- Kang K, Shapley RM, Sompolinsky H (2004) Information tuning of populations of neurons in primary visual cortex. *J Neurosci* 24:3726–3735.
- Kanold PO, Nelken I, Polley DB (2014) Local versus global scales of organization in auditory cortex. *Trends Neurosci* 37:502–510.
- Kim J, Ragozzino ME (2005) The involvement of the orbitofrontal cortex in learning under changing task contingencies. *Neurobiol Learn Mem* 83:125–133.
- Krubitzer LA, Sesma MA, Kaas JH (1986) Microelectrode maps, myeloarchitecture, and cortical connections of three somatotopically organized representations of the body surface in the parietal cortex of squirrels. *J Comp Neurol* 250:403–430.
- Kwegyir-Afful EE, Keller A (2004) Response properties of whisker-related neurons in rat second somatosensory cortex. *J Neurophysiol* 92:2083–2092.
- Le Be JV, Silberberg G, Wang Y, Markram H (2007) Morphological, electrophysiological, and synaptic properties of corticocortical pyramidal cells in the neonatal rat neocortex. *Cereb Cortex* 17:2204–2213.
- Lu SM, Lin RC (1993) Thalamic afferents of the rat barrel cortex: a light- and electron-microscopic study using *Phaseolus vulgaris*

- leucoagglutinin as an anterograde tracer. *Somatosens Mot Res* 10:1–16.
- Lubke J, Feldmeyer D (2007) Excitatory signal flow and connectivity in a cortical column: focus on barrel cortex. *Brain Struct Funct* 212:3–17.
- Mao T, Kusefoglou D, Hooks BM, Huber D, Petreanu L, Svoboda K (2011) Long-range neuronal circuits underlying the interaction between sensory and motor cortex. *Neuron* 72:111–123.
- Mioche L, Singer W (1989) Chronic recordings from single sites of kitten striate cortex during experience-dependent modifications of receptive-field properties. *J Neurophysiol* 62:185–197.
- Miranda M, Bekinschtein P (2017) Plasticity mechanisms of memory consolidation and reconsolidation in the perirhinal cortex. *Neuroscience*.
- Mountcastle VB (1957) Modality and topographic properties of single neurons of cat's somatic sensory cortex. *J Neurophysiol* 20:408–434.
- Narayanan RT, Egger R, Johnson AS, Mansvelder HD, Sakmann B, de Kock CP, Oberlaender M (2015) Beyond columnar organization: cell type- and target layer-specific principles of horizontal axon projection patterns in rat vibrissa cortex. *Cereb Cortex* 25:4450–4468.
- Nishimura M, Sawatari H, Takemoto M, Song WJ (2015) Identification of the somatosensory parietal ventral area and overlap of the somatosensory and auditory cortices in mice. *Neurosci Res* 99:55–61.
- Otsuka T, Kawaguchi Y (2008) Firing-pattern-dependent specificity of cortical excitatory feed-forward subnetworks. *J Neurosci* 28:11186–11195.
- Pereira A, Ribeiro S, Wiest M, Moore LC, Pantoja J, Lin SC, Nicolelis MA (2007) Processing of tactile information by the hippocampus. *Proc Natl Acad Sci U S A* 104:18286–18291.
- Pluta SR, Lyall EH, Telian GI, Ryapolova-Webb E, Adesnik H (2017) Surround integration organizes a spatial map during active sensation. *Neuron* 94(1220–1233):e1225.
- Ragozzino ME, Wilcox C, Raso M, Kesner RP (1999) Involvement of rodent prefrontal cortex subregions in strategy switching. *Behav Neurosci* 113:32–41.
- Ramos JM (2014) Essential role of the perirhinal cortex in complex tactual discrimination tasks in rats. *Cereb Cortex* 24:2068–2080.
- Rodgers KM, Benison AM, Klein A, Barth DS (2008) Auditory, somatosensory, and multisensory insular cortex in the rat. *Cereb Cortex* 18:2941–2951.
- Saiki A, Kimura R, Samura T, Fujiwara-Tsukamoto Y, Sakai Y, Isomura Y (2014) Different modulation of common motor information in rat primary and secondary motor cortices. *PLoS One* 9:e98662.
- Sanes JN, Suner S, Lando JF, Donoghue JP (1988) Rapid reorganization of adult rat motor cortex somatic representation patterns after motor nerve injury. *Proc Natl Acad Sci U S A* 85:2003–2007.
- Schubert D, Staiger JF, Cho N, Kotter R, Zilles K, Luhmann HJ (2001) Layer-specific intracolumnar and transcolumnar functional connectivity of layer V pyramidal cells in rat barrel cortex. *J Neurosci* 21:3580–3592.
- Seung HS, Sompolinsky H (1993) Simple models for reading neuronal population codes. *Proc Natl Acad Sci U S A* 90:10749–10753.
- Shi CJ, Cassell MD (1998) Cascade projections from somatosensory cortex to the rat basolateral amygdala via the parietal insular cortex. *J Comp Neurol* 399:469–491.
- Shimegi S, Ichikawa T, Akasaki T, Sato H (1999) Temporal characteristics of response integration evoked by multiple whisker stimulations in the barrel cortex of rats. *J Neurosci* 19:10164–10175.
- Shimegi S, Akasaki T, Ichikawa T, Sato H (2000) Physiological and anatomical organization of multiwhisker response interactions in the barrel cortex of rats. *J Neurosci* 20:6241–6248.
- Simons DJ, Carvell GE (1989) Thalamocortical response transformation in the rat vibrissa/barrel system. *J Neurophysiol* 61:311–330.
- Sincich LC, Horton JC (2005) The circuitry of V1 and V2: integration of color, form, and motion. *Annu Rev Neurosci* 28:303–326.
- Smith JB, Alloway KD (2013) Rat whisker motor cortex is subdivided into sensory-input and motor-output areas. *Front Neural Circ* 7:4.
- Smith NJ, Horst NK, Liu B, Caetano MS, Laubach M (2010) Reversible inactivation of rat premotor cortex impairs temporal preparation, but not inhibitory control, during simple reaction-time performance. *Front Integr Neurosci* 4:124.
- Staiger JF, Loucif AJ, Schubert D, Mock M (2016) Morphological characteristics of electrophysiologically characterized layer Vb pyramidal cells in rat barrel cortex. *PLoS One* 11:e0164004.
- Stellwagen D, Malenka RC (2006) Synaptic scaling mediated by glial TNF- α . *Nature* 440:1054–1059.
- Sul JH, Jo S, Lee D, Jung MW (2011) Role of rodent secondary motor cortex in value-based action selection. *Nat Neurosci* 14:1202–1208.
- Swadlow HA, Gusev AG (2002) Receptive-field construction in cortical inhibitory interneurons. *Nat Neurosci* 5:403–404.
- Toyoizumi T, Aihara K, Amari S (2006) Fisher information for spike-based population decoding. *Phys Rev Lett* 97:098102.
- Wallace H, Fox K (1999) Local cortical interactions determine the form of cortical plasticity. *J Neurobiol* 41:58–63.
- Wang HP, Spencer D, Fellous JM, Sejnowski TJ (2010) Synchrony of thalamocortical inputs maximizes cortical reliability. *Science* 328:106–109.
- Wang Q, Sporns O, Burkhalter A (2012) Network analysis of corticocortical connections reveals ventral and dorsal processing streams in mouse visual cortex. *J Neurosci* 32:4386–4399.
- White EL (1978) Identified neurons in mouse Sml cortex which are postsynaptic to thalamocortical axon terminals: a combined Golgi-electron microscopic and degeneration study. *J Comp Neurol* 181:627–661.
- White EL, Hersch SM (1982) A quantitative study of thalamocortical and other synapses involving the apical dendrites of corticothalamic projection cells in mouse Sml cortex. *J Neurocytol* 11:137–157.
- Wilber AA, Clark BJ, Forster TC, Tatsuno M, McNaughton BL (2014) Interaction of egocentric and world-centered reference frames in the rat posterior parietal cortex. *J Neurosci* 34:5431–5446.
- Wise SP, Donoghue JP (1986) *Motor cortex of rodents*. New York: Plenum Press.
- Wright N, Fox K (2010) Origins of cortical layer V surround receptive fields in the rat barrel cortex. *J Neurophysiol* 103:709–724.

(Received 3 March 2017, Accepted 13 July 2017)
(Available online xxx)