

Shiyala Village Solar Classroom Project - August 2012

Version	Date	By	Description
0.0	07/09/2012	LT, DR	First Draft
1.0	11/09/2012	LT, DR	Amendment following JEH comments/suggestions. Earthing arrangement decisions described.



1 Introduction

Two School of Engineering staff members designed and installed a solar classroom at a remote medical outpost in Zambia. The School of Engineering lent support to the project by funding the travel costs of Dr Daniel Rogers and Mr Lee Thomas. The work was undertaken with the charity 'Mothers of Africa', led by Professor Judith Hall, whose principal aim is to contribute to the delivery of the Millennium Development Goals by improving medical practice in African countries through education.

The team successfully installed a 1200W solar array with four 220Ah (total capacity 10.56 kWh) AGM batteries. The new system supplies nine computer bays within the classroom, general 230V lighting/power, a vaccination fridge and a neighbouring building.

It is envisaged that the new facility will be used as an adult education facility for the surrounding district. The use of the new facility will be determined by the local community, who contributed labour and time to the project. Whilst the primary aim of the facility is to disseminate best practice in the basics of medicine, the existence of an accessible IT provides a means to improve computer literacy. The facility also enables the possibility of homework/learning club to take place after dark.

2 Overview of Installation

2.1 Preparation

The preparation phase began with briefing sessions attended by Prof. Hall, Dr Rogers and Mr Thomas. In these meetings the team agreed rough building dimensions and project aims. It was agreed that ABESU, a charity specialising in construction and focussing their efforts on the village of Shiyla in Zambia, would arrange for the construction of the building and that Aleutia would be used as the main supplier of the computers and solar panels.

As part of the preparation process draft layouts, schematics and equipment schedules were drawn up. The initial equipment schedule can be found in Appendix I. Appendix IV includes the final schematic drawing. The computers and solar panels were purchased from Aleutia and the remaining items were purchased from RS, Edmundson Electrical and Screwfix. The equipment and tools were shipped, via Aleutia, to Zambia around a month before the team's departure. Owing to their weight, batteries were sourced in Lusaka. After clearing customs the equipment was stored in a secure shipping container near Chongwe.

2.2 In Zambia

The Zambian national health board provided the team with a Toyota Land Cruiser and a driver, Jonathan. The first task, following a brief post-flight nap, was to check that the pre-shipped equipment had survived the journey. Once this was done the new classroom building was visited.

The team arrived to find that concreting of the floor was underway in one room. Whilst there had been some departure from the original plans (e.g. the switchroom and office were swapped) the building was broadly as expected. Introductions were made to the group of around nine men that were working on the building.



Figure 1 - The group of men working on the project on arrival (and Dr Rogers)

The next task was to purchase batteries from a Zambian supplier. A Lusaka based company, 'Sun-tech', was used. The batteries (each weighing around 65 kg) were purchased and taken to site using the Land Cruiser. After picking up the equipment and tools from the lock-up the project was ready to progress.

At the beginning of the week the main equipment items were mounted on the wall of the switchroom. These items included; a rotary isolator, a maximum power point tracker, the 48V-DC distribution board, the 48V-DC to 12V-DC converter, the 12V-DC distribution board, the 48V-DC to 230V-AC inverter and the 230V-AC distribution board. The items were interconnected, in accordance with the schematic, using armoured cabling.

The mounting of the solar panels took around a day and a half. The solar panels selected were four Xunlight XR36 panels. These use amorphous silicon technology and are comparatively flexible. Each of the panels comes with ten fixing grommets attached to flaps along the length of the panel. The panels were secured using eye-bolts (bolted to the corrugated tin roof) and rope. In hindsight, the speed of installation could have been improved by using standard bolts and washers linked directly through the fixing grommets. However, the use of eyebolts did allow for perforation of the corrugated roof at peaks, minimising the chance of water ingress.

The construction of the roof was such that the supply cabling from the solar panels could be threaded through. A small gap was available where the dips in the corrugated roof met the flat panelling at the apex. A junction box was mounted at high level (under the apex of the roof). This contained termination blocks to allow the connection of the solar panels to the Maximum Power Point Tracker (MPPT) in the switchroom.



Figure 2 - The installed solar panels



Figure 3 - Switchroom equipment. Wall mounted equipment from left to right; 230V-AC distribution board (wylex), 3kVA Inverter, 12V-DC distribution board, 48V-DC:12V-DC converter, 48V-DC distribution board (schneider), Maximum power point tracker (Morningstar), solar panel isolator.

An important aspect of the project was the power supply link to the adjacent admin block. To achieve this, a trench was dug and an armoured (3 core 6mm²) cable laid. Within the admin block a distribution board was provided to allow the future wiring of small power and lighting. At each end of

the trench, adjacent to the buildings an earth rod was installed. These were linked using the third core and armour of the cabling.

All extraneous metallic parts were bonded and linked to the building's earth rod. In the new classroom building this involved bonding the roof and the casing of each distribution panel. In the admin block the roof was linked to the earth rod. It was advised that, in the event of a lightning storm, the equipment should be isolated in order to protect it from damage from lightning current surges. The decisions made in relation to the earthing arrangement are summarised below:

- Earth rods were installed at for both buildings (Education Facility and Admin Block). These were bonded to earth bars in the respective 240V distribution panels.
- The metal roofs of both building bonded to earth bars in the respective 240V distribution panels.
- The earths for both buildings connected together over grey core of the armoured cable.
- The earth bars in 48V and 12V panels were directly connected to earth bar in 240V panel in battery room.
- All power electronics kit earths were bonded to respective distribution panel earth bars using grey core of armoured cable.
- The 230V neutral was bonded to earth in battery room and admin building (AFTER RCD!)
- The 12VDC negative was bonded to earth.
- The 48VDC negative was **NOT** bonded to earth.
- The Solar Panel negative was **NOT** bonded to earth

Unfortunately a supplier error was made when the inverter was shipped. The shipped inverter had a rated input voltage of 12V-DC as opposed to the required 48V-DC. Regrettably, this error was only picked up after connection; therefore some damage was caused to the inverter. An alternative inverter was sourced, from Sun-tech, and connected into the system. Happily, the original supplier offered to reimburse the project.

Within the classroom, a 12V-DC system was selected for supply of the computers for three reasons:

- Avoidance of the excessive use of 230V socket outlets (which could overload the system if too much load is connected).
- Avoidance of the use of multiple 230V-AC to 12V-DC converters – thus avoiding an additional conversion stage and improving overall efficiency.
- A separate system means that the computers would be less affected by nuisance tripping of other circuits or by the inverter capacity.

Nine 12V-DC power supply boxes were created to supply each of the computers. Standard DC connectors were used to provide power supplies for the monitors and PCs. Additionally, a flexible 3W LED task light was also connected to each of the boxes. As the 3W lights required a 4V power supply, a small DC-DC converter was included in each of the boxes.



Figure 4 - 12V DC Distribution Box

The Morningstar MPPT was supplied with a remote monitoring kit. The kit monitors the battery and solar panel voltages and the system temperature. It is able to ascertain the system state (i.e. daytime generating or night time standby). It also reports the daily kWh supplied from the solar equipment. The remote monitoring interface was mounted within the solar classroom.

The completed was tested. The system consists of:

- 1200W amorphous silicon solar panels with Maximum Power Point Tracker
- Four 220Ah AGM batteries
- A 12V-DC circuit feeding 9 task lights and two computers (with room for connection of a further 7)
- A 230V lighting circuit for the classroom and office.
- A 230 V power circuit for twin socket outlets in the classroom, office and other teaching space.
- A 230V link to the admin block
- Capacity of future links to the medical output building.



Figure 5 - Installed Computers

2.3 Operation and Maintenance

Instructions for the operation and maintenance of the equipment were given. This included the procedure for energisation and de-energisation of the system. The advised turn on procedure is shown below:

- A: 48V Distribution Board
 - 1. Batteries On
 - 2. Solar On

- B: Panel rotary isolator On
 - 3. 12V Supply On
 - 4. Inverter On

- C: 12V Distribution Board
 - 5. DB isolator On
 - 6. Short Bench On
 - 7. Long Bench On

- D: 230V AC Inverter On
 - 8. Main Switch On
 - 9. RCD On
 - 10. All Lights On
 - 11. Office Lights On

12. Classroom Sockets On
13. Admin Block OFF

The batteries chosen were 12V 220Ah Victron AGM (Absorbant Glass Matt). The lifetime of these batteries is linked to the total number and depth of discharge and re-charge cycles they undergo. For example, the batteries would last for only 200 cycles if discharged and recharged completely but would last for 900 cycles if they are discharged to a minimum of 70% of capacity. Therefore, to conserve battery life, care must be taken to not fully discharge the batteries.

The environment in Shiyala was very dusty in August. During the visit there were some wind gusts, typically lasting no longer than 5 minutes. It was noticed that a fine layer of dust had built up on the panels. It is recommended that panels are periodically wiped over to remove dust as a continued dust build up could adversely affect the panel efficiency. The cleaning could be done with a mop – care should be taken not to stand on, or otherwise apply excessive force to, the panels.

The installed remote monitoring system records the daily output of the solar panels for 200 days. This data would be valuable to assess the utilisation and effectiveness of the system. It is recommended that the data is collected during the next visit and that a local person is trained to monitor the data – perhaps logging it on one of the computers.

3 Lessons Learned

The cabling links between each of the distribution boards were specified as XLPE-SWA-PVC (Cross Linked Poly-Ethylene, Steel Wire Armoured, Poly Vinyl Chloride). Whilst use of this cabling is common industry practice in the UK the armour makes the cable difficult to manipulate, adding to installation time. A possible alternative for consideration in future projects could be the more flexible, triple insulated rubber, H07-RNF cabling.

During installation there was some discussion on whether we could have used smaller cabling sizes. In some cases, for instance the 12V DC circuit, where 10mm² cabling was used, the cable size could have been reduced. This would have increased the voltage drop (and therefore the energy losses) but this could have been kept within acceptable limits by increasing the sending end voltage at the converter (or inverter) if necessary. In order to be certain of minimum cable size specifications cable lengths (and therefore final building dimensions) must be known in advance.

The damage caused on connection of the inverter could have been prevented by more rigorous checking. Whilst the fundamental error was the supplier's and the nameplate label was relatively small, some responsibility for the damage caused to the inverter must lie with the project team. A checking procedure may have helped pick up this issue earlier and the use of a pre-prepared checklist may also have helped.

The use of local suppliers (as opposed to using UK based suppliers and shipping out) has some advantages. Firstly, the administration burden of shipping/customs checking is reduced. The direct injection of money into the local economy may also have benefits. Furthermore, having a local partner may help in resolving any last minute requirements. Finally, if the supplier has relatively large stocks, then less extra allowances need be made in the specification of cabling. However, if the charity were to repeat the solar classroom installation in other countries, building a relationship with UK based suppliers may be preferable.



Figure 6 - The ladder used on site. An Aluminium (or similar) ladder may have increased the speed of installation

One challenge that was faced was how to involve the local workforce as much as possible in the electrical installation whilst making sure that work of sufficient quality was achieved. The workforce was very proficient at building tasks. For instance, a plinth for the batteries was built within a two hours of request. However, they were less familiar with electrical installation techniques. The more that locals can be involved, the better the understanding gained and the higher the sense of ownership afterwards.

A way of involving the local workforce more would be to create detailed drawings showing all cable terminations and fixing techniques. These could be followed by the local workforce and some basic work could start in advance of the arrival of specialists.

On reflection, it is felt that the timescales allowed for the preparation of the design were a little short. Additionally, more time on site would have been useful. Allowing more preparation time would have allowed the team to circulate proposals and to iteratively revise them as required.

Some of the equipment used on site could have been improved. For example, the ladder provided was quite unwieldy and took some getting used to in practice. Also, it was found that some tools were needed at the same time in different places (e.g. wire strippers, pliers, cutters, screwdrivers). In most cases only one tool of each type was taken to Zambia. This sharing of tools occasionally disrupted the flow of work. Finally, the team were highly reliant on a few relatively inexpensive items such as the 5mm drill bit; if this was to have broken it could have disrupted the project. Therefore taking duplicate tool sets would have improved the build rate and reduce risk of disruption due to tool failure – though this would come at the cost of extra shipping. If similar projects are to be undertaken in future, it may be worth creating a permanent tool set in Zambia.

During the installation it was realised that the Admin block could not be completely isolated without isolating all of the 230V circuits. Whilst the live conductor can be disconnected using the single pole Miniature Circuit Breaker (MCB) the neutral conductor will remain connected. This could be relatively easily improved by changing the single pole MCB for a double pole version. Additionally, it is recommended that a separate Residual Current Device (RCD) is installed in the admin block distribution board. This would mean that the Admin building link need not be protected by the RCD in the Education Facility and, if the RCD was by passed (for the Admin Block link only), the risk of nuisance tripping of all 230V circuits would be reduced.

The selected solar panels were flexible, lightweight and relatively easy to install. However, these advantages come at the cost of a reduced efficiency (per m²) – this was offset by allowing for a larger surface area coverage. Monitoring of the installation should be undertaken to allow performance comparison with traditional poly-crystalline silicon panels.

Another improvement would have been clear communication of the desired building orientation at the outset. The roof on which the solar panels were installed was facing north west. The optimum orientation would have been north (Zambia is south of the equator). However, it is not thought that it will mean a large drop in energy inputted to the system. This is because the solar panel suppliers state that the panels work relatively well in ambient (indirect) and also because the direct sunlight not being collected occurs early in the morning (when the incident irradiation levels would be lower in any case).

An aspect of the project that was more time consuming than envisaged was the creation of the 12V-DC distribution boxes. The process involved the dismantling of pre-bought Ikea lamps, soldering of the DC-DC converters and resistors for connection of the lamp and fixing of the switch and lamp to the box. If this had been done before travel to Zambia then some time on-site could have been saved. However, in this project, it would have taken away from precious preparation time in the UK.

Some non-critical bugs were found during the setting up of the computers. These included a slight mismatch in the resolution of the screens and the available graphics output of the computers. Also, a problem where the mouse pointer disappears on hovering over menu items was found. These problems were communicated to the supplier. Finally, it has been suggested that the presentation/format of some of the e-learning materials could be improved.

Summary of lessons learned/improvements for future projects:

- Minimise use of armoured cabling
- Confirm building specification and size earlier, reduce cable sizes where possible.
- Rigorously check supplied equipment, use checklist.
- Find ways to involve local workforce more.
- Increase time allowed for design, ordering of equipment and installation (or reduce size of project)
- Consider taking duplicate tools.
- Agree suitability of onsite equipment (e.g. ladders) prior to travel
- Re-consider solar and battery technology (using this project as reference)
- Communicate desired orientation of building to construction team in advance.
- Consider format of e-learning material.

4 Future Plans

The next phase of the project at Shiyala is the connection of the health output building and the provision of the remaining 7 computers. This would take approximately 10 man days and would involve the following tasks:

- Wire lighting and sockets for administration building
- Lay cable to health post and install health post distribution board
- Wire lighting and sockets for health post
- Install remaining 7 computers

Provisionally, this could take place (assuming the same team) in March or July 2013. July would be preferable as there is less conflict with the academic year.

A further option would be return in July 2013 with an undergraduate team. Performing the same tasks but involving undergraduates from engineering (2nd or 3rd years). This may be attractive from the

School of Engineering's point of view as it could be used as a recruitment tool for prospective undergraduates. This may bring about future collaboration and regular visits by the school. The following advantages may exist if this option is taken:

- The School of Engineering is more likely to provide travel funds if a recruitment opportunity is created
- Students may be able to fundraise
- A shorter trip may be possible with more hands available
- A successful 3rd year project run during 2012-13 may deliver improved Linux installation and e-learning software on the computers, providing a better experience than the relatively crude software in use now.

However, there would be many challenges associated with taking relatively inexperienced undergraduates out:

- Funding (flights, accommodation, transport within Zambia)
- Liability/insurance
- Recruitment – Just electrical engineering or expand to civil and mechanical?
- Supervision load for Dan/Lee during the year (possibly could make this the 3rd year project for 2-4 students?).

5 Acknowledgements

Dan and Lee would like to thank everyone involved with making the trip happen. Special thanks go to Prof. Judith Hall who arranged the trip and showed great patience in procuring the replacement inverter! Thanks also to Alison, Buddug and Clara for their support throughout and to Jonathan, Dr. Charles Msiska, Charles Banda and all of the Zambian workers for doing most of the hard work.

Thanks to everyone who helped and supported in the School of Engineering including Prof. Karen Holford, Prof. Nick Jenkins, Dr Janaka Ekanayake, Dr Tracy Sweet, Paul Farrugia and Steve Mead.

Finally, thanks Debbie and Laura for their patience and support.

6 Appendix I – Initial Equipment Schedule

Note. The equipment schedule does not include all equipment taken. Also some items/suppliers/costs were changed.

Zambia Solar Classroom: Equipment list

Last revision: LT 23/07/2012

Notes

The basic plan is for a classroom that can support up to 10 computers, each drawing 35W max. We also want to be able to supply 240Vac power to a nearby building, as well as providing some basic 240Vac power in the classroom for standard CCFL lighting, extractor fans etc.

Maximum 12Vdc load is 400W, maximum 240V load is 1500W. We have chosen a 48Vdc battery voltage to lower the maximum current seen in the design. Items highlighted in green will probably be sourced from Aleutia (RS part nos. given for reference). The remaining kit will be sourced from RS or local electrical suppliers.

Item	Notes	No. or meters	Manufacturer	Model Name	Supplier	Supplier part no.	Mass each (kg)	Total mass (kg)	Cost ex VAT	Line cost ex VAT
PV panels, 1.2kW peak output total	approx 4kWh/day?	4	Xunlight	XR36-291-R2/R3	Aleutia		12	48	650.00	2600.00
PV charge controller, 48V battery capable	60A gives up to 2.9kW solar capacity (future expansion?)	1	Morningstar	TS-MPPT-60	Aleutia		4.2	4.2	650.00	650.00
Batteries, 4x 12V 200Ah	4.8kWh with 50% charge-discharge cycle	4	RS	Gel Cyclic	In Zambia	689-5851	61	244	662	2648
48Vdc - 240Vac 1.5kW Inverter	Capable of 3kW peak (e.g. laser printer load)	1	Cotek	SK1500-248	Aleutia		5	5	470.00	470.00
48Vdc -12Vdc Converter, 500W	Eliminates need for computer screen adaptors	1	RS	SD-500	RS Online	491-267	1.2	1.2	185	185
Main 4 Way Distribution Board										
4 way panel assembly	Includes 100A incoming isolator	1	Schneider		RS Online	528-9494			35.72	35.72
63A 48Vdc 2 pole MCB Type B	Checked DC rated up to 125V	1	ABB		RS Online	131-898	0.5	0.5	31.98	31.98
12A 48Vdc Isolator	Standard 100A incoming disconnector (cheap!)	1	Square D		RS Online	340-5076	0.5	0.5	10.34	10.34
240Vac 6 Way Distribution Board										
Twin RCD 4 + 2 split board assembly	Includes 100A incoming isolator and 2 x 30mA RCDs	1	Wylex		RS Online	569-584		0	74.75	74.75
3A SPN MCB 240Vac Type C		2	ABB		RS Online	131-999	0.5	1	31.71	63.42
6A SPN MCB 240Vac Type C		2	ABB		RS Online	132-015	0.5	1	30.19	60.38
10A SPN MCB 240Vac Type C		1	ABB		RS Online	132-071	0.5	0.5	27.73	27.73
12Vdc 4 Way Distribution Board										
4 way panel assembly	Includes 100A incoming isolator	1	ABB		RS Online	453-974			35.72	35.72
50A 12Vdc Isolator	Standard 100A incoming disconnector (cheap!)	1	Square D		RS Online	340-5076	0.5	0.5	10.34	10.34
16A 12Vdc 2 pole MCB Type B	Checked DC rated up to 125V	3	ABB		RS Online	131-933	0.5	1.5	27.73	83.19
Cabling										
16mm XLPE-SWA-PVC 3 core	15m - 48Vdc PV Cntrlr to Panel, Batteries to Panel, Panel to Inv.	15	Prysmian		Edmundson Electrical			0		0.00
10mm XLPE-SWA-PVC 3 core	10m - 48Vdc supply to DC converter, 12Vdc supply to Panel	10	Prysmian		Edmundson Electrical			0		0.00
10mm LSF Twin and Earth	40m - 12Vdc supply for computers/LEDs	40			Edmundson Electrical			0		0.00
6mm XLPE-SWA-PVC	50m - 240Vac supply to admin block, supply for Panel	50	Prysmian		Edmundson Electrical			0		0.00
2.5mm Twin and Earth	50m - 240Vac Lighting and Small Power	50			Edmundson Electrical			0		0.00
10mm LSF Earthing and Bonding Cabling 1 core	50m	50			Edmundson Electrical			0		0.00
Accessories										
Mounting board		3						0		0.00
Flexible conduit		25			Edmundson Electrical			0		0.00
Junction boxes		15			Edmundson Electrical			0		0.00
Conduit clips		100			Edmundson Electrical			0		0.00
Cable clips		100			Edmundson Electrical			0		0.00
Chocolate blocks		25			Edmundson Electrical			0		0.00
Armoured cable glands	Check suitable for 6 - 16mm cable	14			Edmundson Electrical			0		0.00
Cable ferrules		100			Edmundson Electrical			0		0.00
Light Fittings										
2 way light switch and back boxes, surface mount		6			Edmundson Electrical					
1 way light switch and back boxes, surface mount		1			Edmundson Electrical					
11W 240Vac CCFL with pendants		10			Edmundson Electrical			0	15.00	150.00
3W LED lamps for benches (12Vdc)		10			Ikea			0	15.00	150.00
Earthing										
Earth rod	400mm	2			Edmundson Electrical					
Earth bar	8 way 6mm	1			Edmundson Electrical					
Computers										
T1 pro base unit (60GB SSD, Edubuntu)		10						0	269	2690.00
Screens (12Vdc)		10						0	155	1550.00
Mouse, keyboard, (speakers/headphones?)		10						0	30	300.00
Totals								307.9		11826.57

7 Appendix II – Solar panel output simulation

Zambia solar school project.

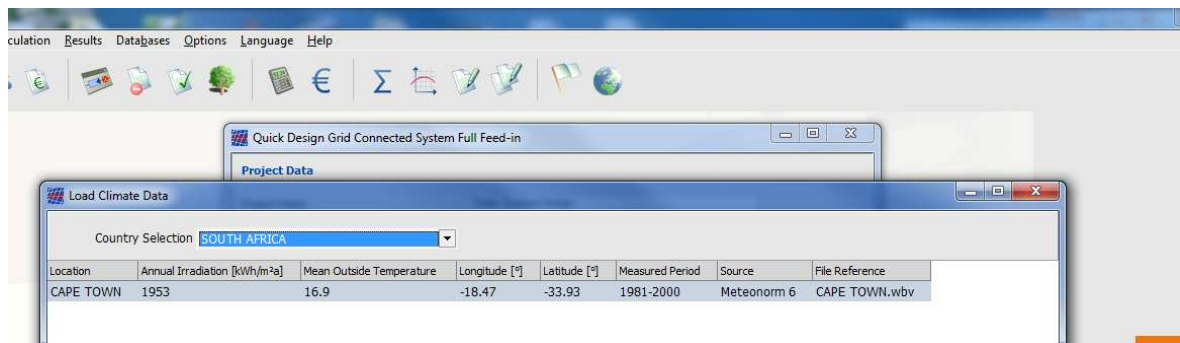

Please enter under Options-> Settings
 Please enter under Options-> Settings
 Please enter under Options-> Settings
 Please enter under Options-> Settings
 Please enter under Options-> Settings

Project Name: Solar System Design 6/27/2012
 Variant Reference: System Variant

Location:	CAPE TOWN
Climate Data Record:	CAPE TOWN (1981-2000)
PV Output:	1.16 kWp
Gross/Active PV Surface Area:	18.88 / 18.77 m ²

PV Array Irradiation:	40,161 kWh
Energy Produced by PV Array (AC):	1,960.7 kWh
Grid Feed-in:	1,960.7 kWh

System Efficiency:	4.9 %
Performance Ratio:	78.5 %
Inverter Efficiency:	90.5 %
PV Array Efficiency:	5.4 %
Specific Annual Yield:	1,679 kWh/kWp
CO2 Emissions Avoided:	1,732 kg/a

100% | 1/1

8 Appendix III – Equipment Manuals/Data Sheets

Available on request: Email ThomasL62@cf.ac.uk

Note. A hard copy of all available manuals and data sheets was left in the Electrical Switchroom at the new Shiyala Education Facility..

9 Appendix IV – As-Installed Electrical Schematic

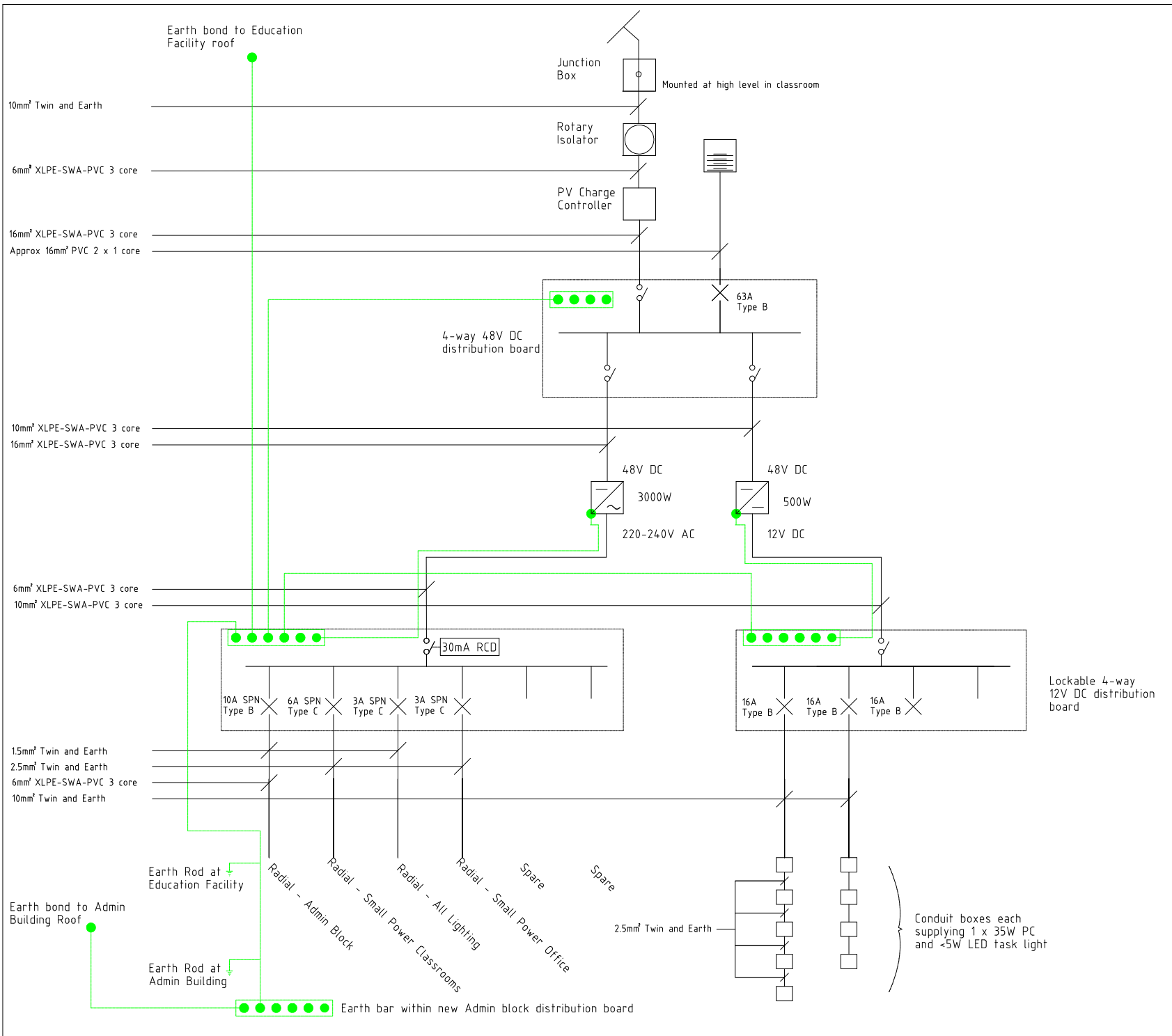

PROJECT: Zambia Solar Classroom

TITLE: Electrical Power Schematic

REVISION: D3

STATUS: As Installed

DRAWN BY: LT

CHECKED: DR

REVISION HISTORY:

D1: 23/06/2012 - First Draft

D2: 24/06/2012 - Update

D3: 14/09/2012 - As Installed