

Setting the Stage for Ageing: Life-course Influences on Neural Health and Implications for Prevention Science

Stephanie Jane Baker

Thesis submitted for the degree of Doctor of Philosophy

School of Psychology, Cardiff University

January 2018



Acknowledgements

I would like to acknowledge and thank the below for their support.

My supervisor Professor Andrew Lawrence for valuable feedback on chapters, support for inter-disciplinary approaches, and awareness of what seems like 99% of all published literature! Thank you for your patient and resilient approach to a complex research area.

Thank you to everyone involved in the CUBRIC 1000 brains project (participants, data collection, processing). Thank you to my research group who I was able to enjoy working with as part of a larger ongoing project. Thanks towards everyone who assisted in the collection of neuropsychology assessments, particular thanks to Rebecca, Alison, Martina, and Matt for their work scanning and processing, and thank you to all those who participated. I am especially grateful to Dr Rebecca Cavill, who was able to patiently walk me through image analysis. I am grateful for a lab group who were not just colleagues, but kind, supportive, and fun friends throughout an otherwise stressful experience!

Thank you to Professor Greg Maio and Professor Geoff Haddock, who assisted with early social psychology work including pilot surveys, and to Dr Elspeth Spence for her clear guidance regarding incorporating thematic analysis. Initial input from a social psychology perspective was key in shaping this thesis.

Thank you to the ESRC for funding and the Cardiff School of Psychology for the supportive environment.

I am also personally very grateful to my family and friends, who supported me through both failing projects and long days compiling data.

Summary

This two-part thesis aimed to bring together health psychology and the emerging field of health neuroscience, building a greater understanding of cognitive health across a life-course and with a focus towards research that has public impact.

The thesis is structured in two parts.

Part 1 focused on health neuroscience, investigating two key factors that could impact MTL structure and memory processes within a multi-factor model (STAC-R). Chapter 2 looked at a potential genetic modifier of life-course cognition, *BDNF*. Results suggested differences in parahippocampal structure, and hippocampal-amygdala structural covariance dependent on the presence of a Met allele. Chapter 3 examined the relationship between physical activity, the above regions, and everyday memory function in healthy young adults. Results found no physical activity link with hippocampal or amygdala volume, or parahippocampal thickness. However, vigorous physical activity in study 2 was correlated with semantic memory and is discussed in the context of a multi-factor model of cognitive health.

Part 2 focused on health psychology, aiming to identify factors that influence attitudes towards risk and safety in sports, with a view to ultimately guiding policy and interventions that could optimise cognitive development and minimise decline in later-life. Chapter 4 acts as an introduction to literature on attitudes in sports related concussion, discussing theoretical models, and their role in three key areas; prevention, management, and symptomology. Chapter 5 utilised an online survey and a mixed-method approach to look at parental concussion attitudes and knowledge. Predictive factors are described in relation to parental knowledge and whether they would allow their children to engage in contact sports such as rugby and football. Further thematic analysis highlighted misperceptions of risk, genetic fatalism, and the importance of control. Sources of information and poor service awareness are discussed.

The included work supports a multi-factor model of cognitive health over the life-course and suggests methods for effective knowledge transfer or intervention initiatives.

Table of Contents

Declaration.....	1
Acknowledgements.....	2
Summary	3
1. General Introduction.....	6
Life-Course Influences on Cognitive and Neural Health and Well-Being.....	7
Life-course Cognitive Health, Neuroplasticity and the Uniqueness of the Medial Temporal Lobes.....	12
Genetics: role of BDNF genotype.....	18
Physical Activity Influences on Brain Structure in Humans	21
Attitudes and Knowledge.....	24
Current Work	25
Part 1: Health Neuroscience	29
2. Brain-derived neurotrophic factor (<i>BDNF</i>) Val66Met polymorphism linked to brain structure and brain structure covariance in healthy adults	30
Introduction	30
Methods and materials.....	36
Results.....	38
Discussion.....	41
3. Does Physical Activity Predict Hippocampal Volume and Everyday Memory in Healthy Young Adults?	47
Introduction	47
Study 1	54
Methods.....	54
Results.....	57
Study 2	58
Methods.....	58
Results.....	60
Discussion.....	62
Part 2: Health Psychology	67
Introduction	67
4. A Narrative Review of Health Attitudes Research in Mild Traumatic Brain Injury	69
Introduction	69
Methods.....	71
Results and Discussion.....	71
Prevention.....	71
Management.....	73

Symptomology	79
Summary and Recommendations	81
5. Factors Affecting Contact Sport Attitudes and Knowledge in Parents	83
General Introduction.....	83
General Methods	89
Part 1: Parental Concussion Attitudes, Knowledge, and Predictors.....	93
Results.....	93
Discussion.....	97
Part 2: Parental Considerations Towards Child Participation in Contact Sports: Thematic Analysis	103
Methods.....	103
Key Themes, Results and Discussion.....	106
Conclusion.....	123
Part 3: Sources of Information, and Awareness of Relevant Services	124
Results.....	124
Discussion.....	128
Concluding Remarks.....	130
6. General Discussion.....	134
Summary of findings, implications, limitations, and directions for future study	135
Implications for the development of future interventions.....	146
References	149
Appendices.....	173

1. General Introduction

Recent advances in neuroimaging technology have allowed for improved understanding of brain structure and function in greater detail, increased its utility as an early predictor or biomarker of potential neurodegeneration, and added to our understanding of genetic influences on brain structure and function (Risacher & Saykin, 2013; Shenton et al., 2012). However, the brain does not function in isolation, instead being at the mercy of both its owner's choices and experiences, and the environment the individual is in. A large body of research has shown the potentially negative effects on cognition of lifestyle factors including smoking, overconsumption of alcohol, and obesity (Baumgart et al., 2015). The field of health psychology has long informed the production and dissemination of advisory content on these topics to the public and at-risk individuals attempting to reduce these potential negative effects and associated high medical costs (Erickson, Creswell, Verstynen, & Gianaros, 2014; Taylor, 1999). More recently, with current research informing multifactorial models of cognitive health, the field of health psychology is being integrated in to an emerging field of neuroscience; health neuroscience (Erickson et al., 2014).

Health neuroscience is concerned with an individual's overall physical, and neural, health, distinguishing it from health psychology considerations of social, cognitive, and emotional health and wellbeing (Erickson et al., 2014). The study of cognition and aging has already demonstrated integration of psychological and neuroscientific methods and theories and allows for a greater understanding of cognitive functioning over the life-course. Taking a health neuroscience approach allows for the study of how the brain affects and is in turn affected by physical health factors, with the aim of modelling how the brain links genetic, psychological, social, and environmental influential factors in the overall framing of an individual's physical health (Erickson et al., 2014). As can be seen in Figure 1-1, the health neuroscience approach treats the brain as both the target of bottom-up effects of factors such as health behaviour and genetic predisposition, and the cause of top-down mediating effects. Importantly it highlights the roles of further external factors as 'contextual influences', including social, cultural, policy implications, and the potential effect of interventions. This broader model of health and the reciprocal relationship between the brain and

physical health determinants is vital to developing greater understanding of life-span cognitive health and the potential for interventions.

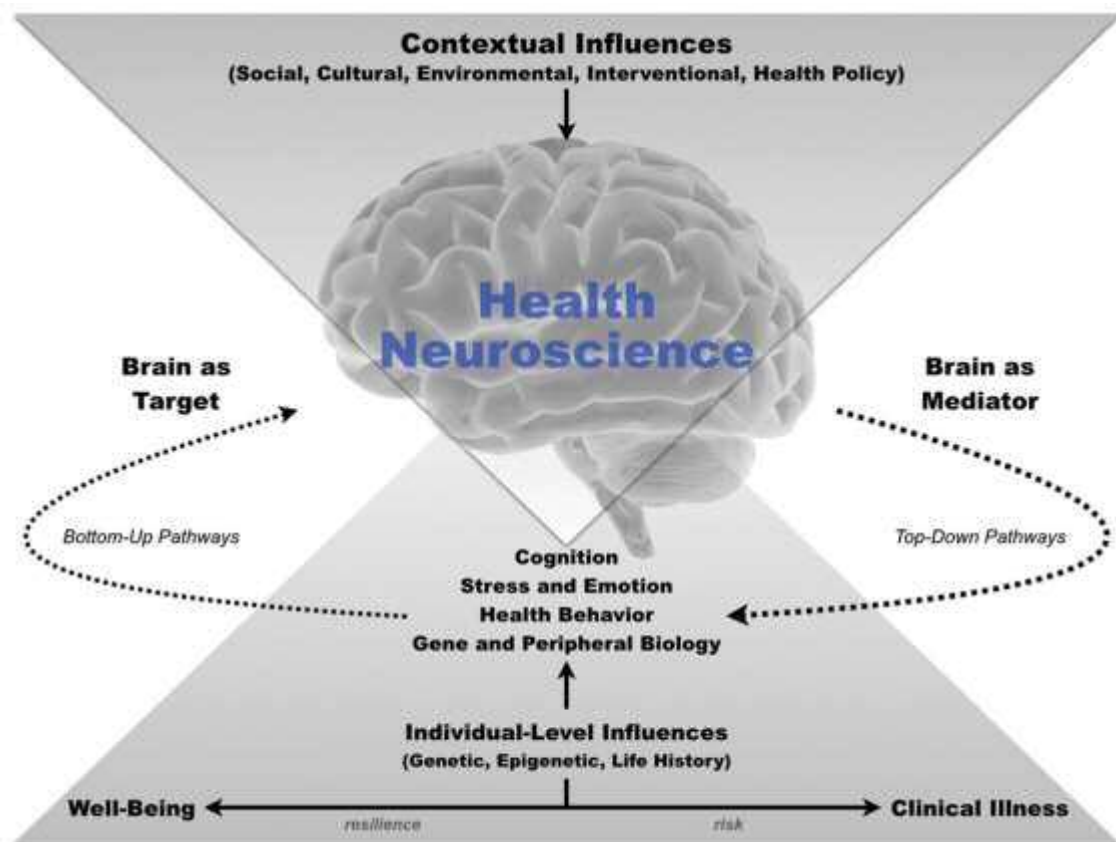

Figure 1-1. Health neuroscience theoretical model from Erickson et al., 2014, p.448

Life-Course Influences on Cognitive and Neural Health and Well-Being

There is an increasing consensus that disorders previously associated with late life (e.g. dementia) are not determined in any single period, but result from the complex interplay between genetic and environmental influences acting across the lifespan (Walhovd, Fjell, & Espeseth, 2014). Life-course cognitive health and well-being refers to an individual's neural health and cognitive performance from childhood to older adulthood and must consider how this can fluctuate in a dynamic fashion throughout a life-time. Whilst of course childhood influence on later life cognition has been well-documented, for example with intelligence tests of pre-teen children predictive of cognitive performance at the age of 90 (Walhovd et al., 2014), more recent literature suggests ongoing experiences and behaviour throughout the life-span can alter long term cognitive functioning. This approach to cognitive health differs from the common

literature focus on neurodegeneration, and the typical 'negative' approach suggesting that outcomes are determined primarily by age. Current research aims to move away from referring to such cognitive degeneration as normal ageing, instead modelling for 'optimal' ageing (Lockhart, DeCarli, & Fama, 2014) in which there is a greater understanding of positive and negative contributing factors for cognitive health over the whole life-span. Goh and Park (2009) supported this shift in direction, instead aiming to build a better picture of how adults can function, adapt, and influence their cognitive well-being across their life-span. With the brain regions affected by 'normal' ageing overlapping with those where degeneration is present in Alzheimer's disease (Van der Linden & Juillerat Van der Linden, 2016), it is key to disentangle what is normal ageing and what is cognitive degeneration, in the context of fluctuation across life and the ageing process (Walhovd et al., 2014).

When considering such a life-course approach, it is immediately clear that multiple contributing factors will be involved in determining cognitive health at various points in the lifespan. This contrasts with historical work on ageing and in particular the decline of memory functioning in older adults. A review of cognition and ageing theories over the last fifty years noted the development from single-mechanism perspectives on degeneration cause, to larger multi-factor models (Park & Festini, 2016). Original models of memory decline over the life-course, based on both human and animal research, originally focused on single cognitive factor models such as processing speed, processing resources, and inhibition ability (Park & Festini, 2016). Alternative non-cognitive factors were focused on to a lesser extent, suggesting degenerative effects of lack of motivation, increased anxiety, altered performance goals, and overall poorer health (Park & Festini, 2016). In the 1980's, theorising shifted to multifactorial modelling, integrating multiple individual differences and highlighting the most critical factors. An individual's brain is constantly developing throughout their life-time. The influence of a single genetic protection or risk, or environmental trauma or adaptive behaviour alone, cannot predict overall cognitive wellbeing (Jagust & Mormino, 2011). Through natural ageing and experiences "new neurons may be formed while others will die, some dendrites will branch while others retract, and new synapses are created while others are eliminated" (Killgore, Olson, & Weber, 2013, p.1). This has been applied to cognition in ageing, with epidemiological data describing

a reduction of cognitive abilities with age as a result of multiple influences over a whole life-course including, physical activity, education level, social support, diet, stress, and environmental toxins and traumas (Van der Linden & Juillerat Van der Linden, 2016). An important level of human agency is also added, supported by work finding that life-style changes, environmental adaptations, and the use of cognitive strategies, especially in the context of memory, show the ability to reduce cognitive decline in older adults (Goh & Park, 2009). Whilst such intervention factors commonly come under the field of health psychology, they are also increasingly investigated by neuroscience. Functional imaging findings show older adults utilise an often different and broader pattern of neural regions, frequently more bilateral, than young adults in various processing and memory tasks (Goh & Park, 2009). Structural imaging studies show the capacity for potential reversal of age-related neural atrophy via intensive physical and cognitive interventions (Walhovd et al., 2015). Such findings suggest potential adaptation to ageing, via the recruitment of alternate and additional processing pathways, or potential structural remodelling.

Models attempting to describe cognitive health over the life-span, the Scaffolding Theory of Cognitive Aging (STAC) for instance, make it clear how multiple impactors can have an ongoing and complex influence.

A Life Course Model of The Scaffolding Theory of Aging and Cognition (STAC-R)

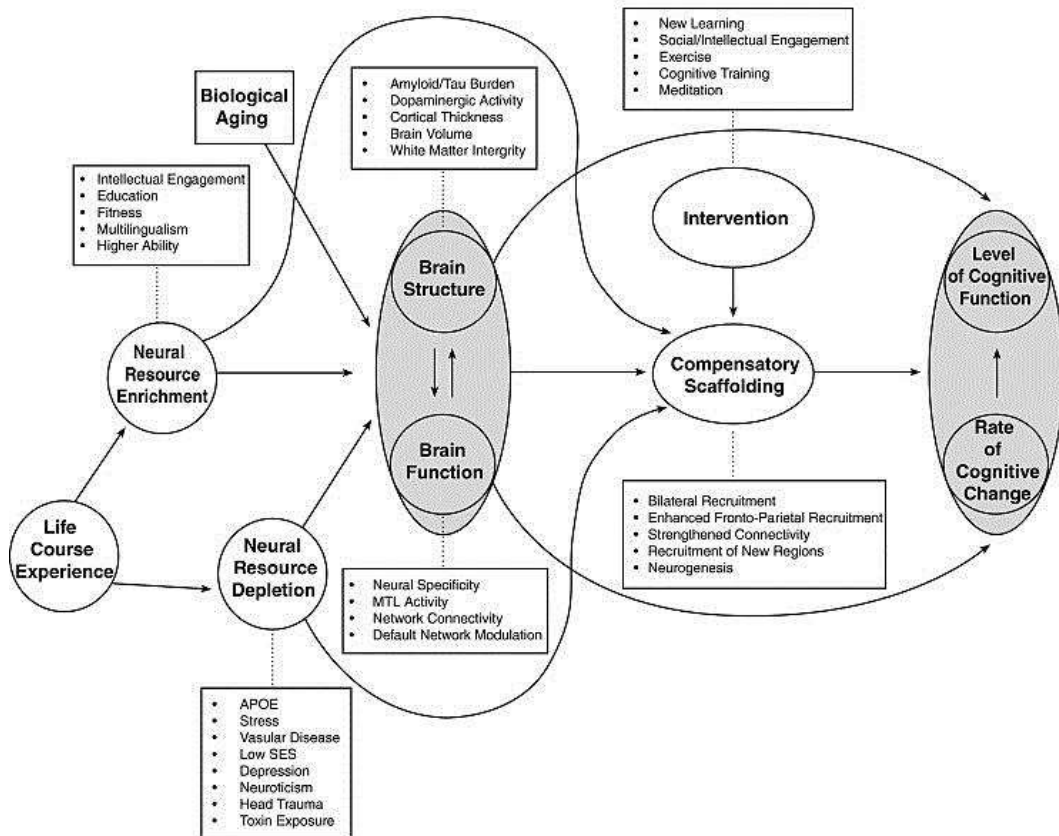

Figure 1-2. Conceptual STAC-R model from Reuter-Lorenz & Park, 2014, p.360

The STAC model describes how an individual may be able to use compensatory scaffolding in order to maintain cognitive wellbeing across their life span by engaging in modifiers such as exercise or meditation (Goh & Park, 2009). It is built on theories of brain and cognitive reserve and resilience, which describe neural and cognitive processing tolerance to pathologies (such as Alzheimer related plaques and tangles) across the life-span (Reuter-Lorenz & Park, 2014) (Rutter, 2006). The shift to multifactorial modelling of cognitive health across the life-course lead to the revision of the original to a STAC-R model (Figure 1-2), incorporating extra factors and compensatory mechanisms that could influence brain structure and cognition in positive or negative ways (Reuter-Lorenz & Park, 2014). It included less direct influences such as those that could increase an individual's ability for 'compensatory scaffolding'. The authors provide the example of education, which may not prevent cognitive decline but instead allow for increased neural compensatory development, allowing the individual to uphold a high level of cognitive processing despite underlying neurostructural and functional changes. As can be seen in Figure 1-2, the

STAC-R is a more complex development of the original STAC model, describing brain structure and function as having reciprocal influence on each other. This is described as being influenced by biological aging and life course experiences, importantly considering both those factors that could cause “neural resource enrichment” such as education and fitness, and those that could cause “neural resource depletion” such as genetics, head injury, and stress.

The model suggests two paths by which “enrichment” effects operate. First, neural enrichment could directly enhance brain structure by promoting increasing cortical thickness, synaptic density and other indicators of neural health. For example, high level of cardiovascular fitness will influence brain structure directly, via increased secretion of brain-derived neurotrophic factor (BDNF) or improved vasculature (Erickson et al., 2013). The second pathway is less direct, in that life course enrichment factors could increase the capacity for compensatory scaffolding protection against the expression of cognitive decline in the face of neural insults that occur with older age. For example, individuals with Alzheimer related pathology but intact cognitive function show enhanced fronto-parietal activity relative to those with impaired cognition (Elman et al., 2014).

The second construct, ‘neural resource depletion’, constitutes negative influences on brain structure, neural function and ultimately cognition, as shown in Figure 1-2. One factor that has an especially powerful depletion effect is the presence of risk genes including the *APOE-4* gene and the *BDNF* Val66Met polymorphism, which increase the risk of cognitive decline in late life, but which have been associated with alterations in brain structure in early life (Jagust & Mormino, 2011). Other factors that are more controversially related to remote cognitive effects include mild traumatic brain injury (mTBI) (Perry et al., 2016) and chronic stress (Katz et al., 2016), amongst others (Figure 1-2). Mild TBI can occur from a blow to the head or body and can result in a range of short term symptoms such as headaches and difficulties with memory (Doolan, Day, Maerlender, Goforth, & Gunnar Brolinson, 2012). Recent meta-analyses show that head injury increases an individual’s risk of developing any form of dementia (Y. Li et al., 2017), and is associated with the development of neurological and psychiatric illnesses such as depression, mild cognitive impairment, and mixed affective disorders. Links have also been made between repetitive mTBI over a life-span and later

development of the neurodegenerative disease Chronic Traumatic Encephalopathy (CTE) (Dewitt, Perez-Polo, Hulsebosch, Dash, & Robertson, 2013; Smith, Johnson, & Stewart, 2013). This is of particular interest in a life-course approach to cognitive health, as a common cause of mTBI is contact sports such as football, horseracing, and rugby (Dewitt et al., 2013), in which the injury is being termed SRC (sports related concussion) (Marshall, 2012). There is potential that participation in an 'enrichment' behaviour such as physical activity could also present negative risks.

Life-course Cognitive Health, Neuroplasticity and the Uniqueness of the Medial Temporal Lobes

As alluded to above, the ultimate determiner of life-course changes in cognition and compensatory scaffolding is neuroplasticity. Neuroplasticity is the key to an individual's ability to adapt and develop in the face of potential cognitive decline, involving the production of new tissue and responding to changing biological and environmental circumstances (Goh & Park, 2009). It is the brain's ability to reorganise, and form and reinforce new connections through processes including (but not limited to) neurogenesis. Neurogenesis has been described as "the proliferation, survival, and differentiation of neural precursor cells into mature neurons or glia that are integrated into the rest of the brain structure" (p. 6) (Goh & Park, 2009). It is the biological process of new tissue development and reinforcement that underlies learning throughout life. Neuroplasticity accounts for how organisms with the same genotype can still show developmental differences due to environmental factors, as their brains adapt and re-form (Walhovd et al., 2016).

Research has demonstrated how neuroplasticity can fit within a multifactorial model of life-span cognitive health. For example, animal work suggests two potential influences and multiple routes for neural scaffolding; Physical exercise can increase the proliferation of neural precursor cells whilst cognitive stimulation (for example memory tasks or language learning) can increase the survival of these new cells (Goh & Park, 2009). Where original research was conducted in animals, post mortem, in-vitro, and neuroimaging work has found evidence for experience-dependent neuroplasticity in adult humans (Goh & Park, 2009; Walhovd et al., 2016).

One notable example of neuroplasticity in the adult human brain comes from the investigation of London taxi drivers who learn “the knowledge”, becoming expert navigators of the local area showed increased volumes of the hippocampus on structural MRI (Maguire et al., 2000). Neuroplasticity is, however, a double-edged sword – it has been suggested that regions characterized by a high degree of life-long plasticity are vulnerable to degeneration in aging (Fjell et al., 2014; M. Mesulam, 1999). The medial temporal lobe, including the hippocampus (see Figure 1-3), seems to be unique in its potential for lifelong neuroplasticity (Raslau et al., 2015). The dentate gyrus of the hippocampus in particular, is a key brain area for adult neurogenesis (Goh & Park, 2009). However, MTL areas with high levels of neuroplasticity are typically seen as more vulnerable to the effects of ageing and degeneration (Walhovd et al., 2014), and could act as early predictors of developing abnormalities. The entorhinal cortex and hippocampus are often highlighted in dementia research, showing signs of atrophy and the presence of NFTs (neurofibrillary tangles), with degeneration commonly accelerating past the age of 60 (Walhovd et al., 2014). Yet hippocampal atrophy is also seen in older individuals who do not harbour Alzheimer’s pathology (Fjell et al., 2014), suggesting that hippocampal atrophy can be modulated by processes other than neurodegeneration.

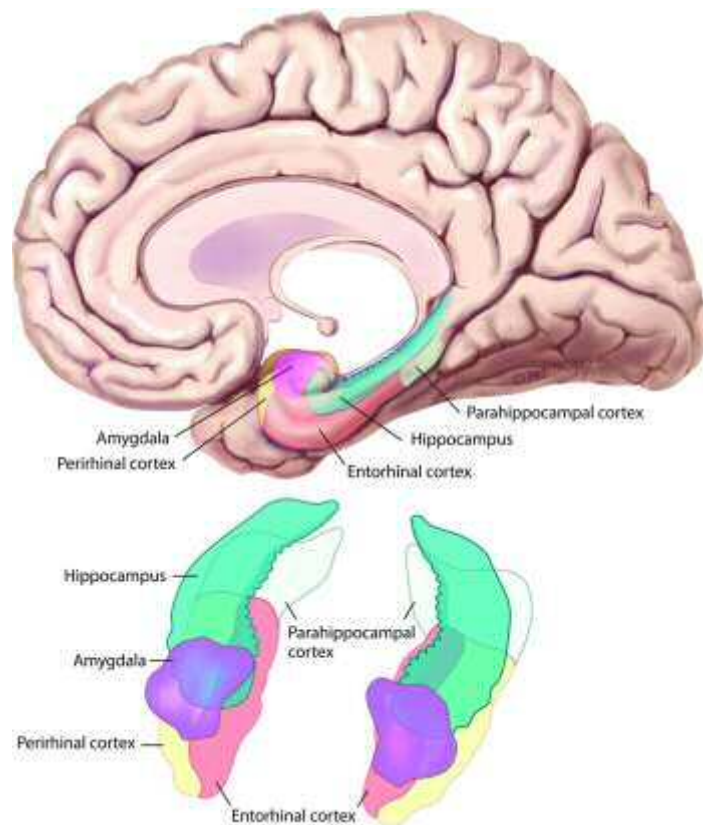

Figure 1-3. The media temporal lobe, modified from Raslau et al., 2015, p.846

MTL neuroplasticity is linked to its well-established role in learning and memory (Murray, Wise, & Graham, 2016). In human adults, the MTL in particular shows marked inter-individual differences in activity, connectivity and structure (Walhovd et al., 2016) that have been related to individual differences in real world memory performance (Palombo et al., 2018; Sheldon, Farb, Palombo, & Levine, 2016). Large hippocampal volume has been linked with better everyday memory (Bailey et al., 2013; Palombo et al., 2018). Conversely, the development of mild cognitive impairment in patients and conversion to dementia is predicted by a decrease in hippocampus size (Fotuhi, Do, & Jack, 2012).

Given the neuroplasticity potential (both beneficial and detrimental) of the MTL, an important aim is to ascertain which modifiable factors can have a positive effect on the size of the hippocampus throughout life. Chronic psychological stress appears to be one such important factor (Fotuhi et al., 2012). This likely reflects the hippocampus' role in both memory and emotion processes, including stress (Murray, Wise & Graham, 2016). Hippocampal structural differences have been identified between healthy participants and patients with clinical depression, bipolar disorder and post-traumatic

stress disorder (see Figure 1-4) (Fotuhi et al., 2012). Emotional disorders such as anxiety and depression have been linked to later life cognitive decline. Longitudinal twin work carried out over 28 years linked anxiety, independent of depression, to the subsequent development of dementia (Petkus et al., 2016). The authors suggest a potential role for chronic stress, in which chronic hyperactivation of the hypothalamic-pituitary-adrenal axis and prolonged exposure to glucocorticoids can ultimately cause hippocampal atrophy, as demonstrated in causal experiments in animal models (Petkus et al., 2016).

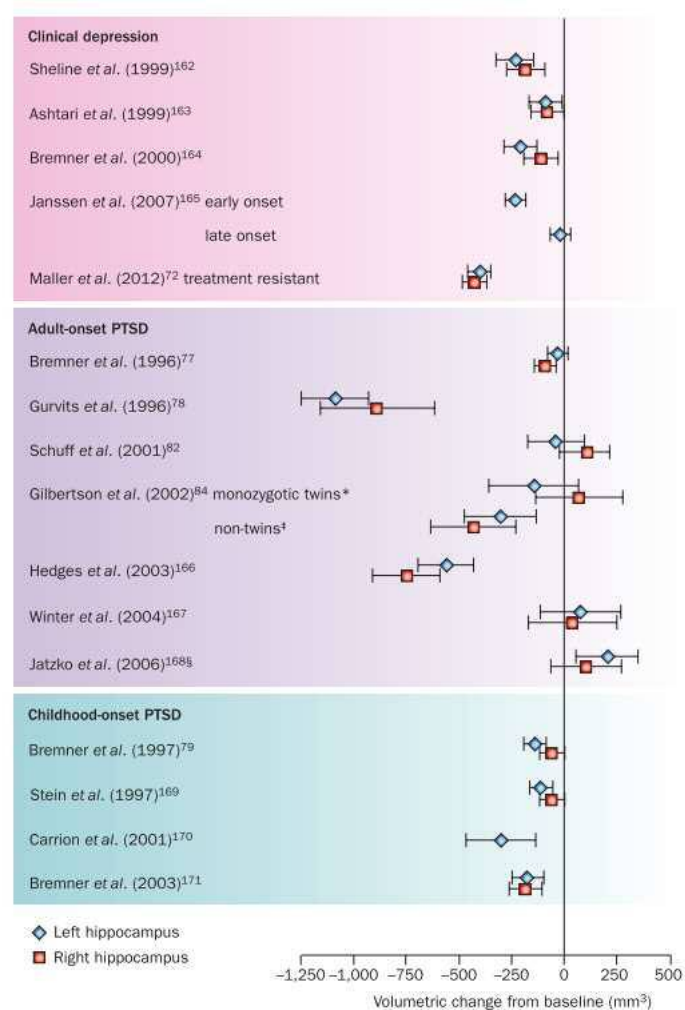

Figure 1-4. Comparison of studies in hippocampal volume in clinical depression and PTSD 1995-2012, demonstrating a link between clinical depression and small hippocampal size. Modified from Fotuhi et al. (2012) p.192

A map (the “dynamic polygon model”) derived by (Fotuhi et al., 2012) (see Figure 1-5) aimed to describe hippocampal growth, maintenance and atrophy in a multi-factor

model including elements previously described in the STAC-R model of Reuter-Lorenz and Park (2014). The dynamic polygon model includes modifiable factors that could influence growth such as physical exercise, cognitive stimulation, and meditation (similar to previous descriptions of positive interventions). It also includes the potentially negative or resource-depleting effects of traumatic brain injury, depression, and Alzheimer’s disease risk genes and pathology, among other factors. Importantly the model does not define such growth and atrophy related factors as simple predictors of outcome, instead linking them to a range of mediators and moderators, which themselves overlap and interact. For example, physical exercise may act as a modifier or mediator of the effects of BDNF genotype, which may allow for hippocampal growth, however this in turn may be influenced by other potential mediators and moderators influencing hippocampal size including cortisol levels linked to depression and chronic stress.

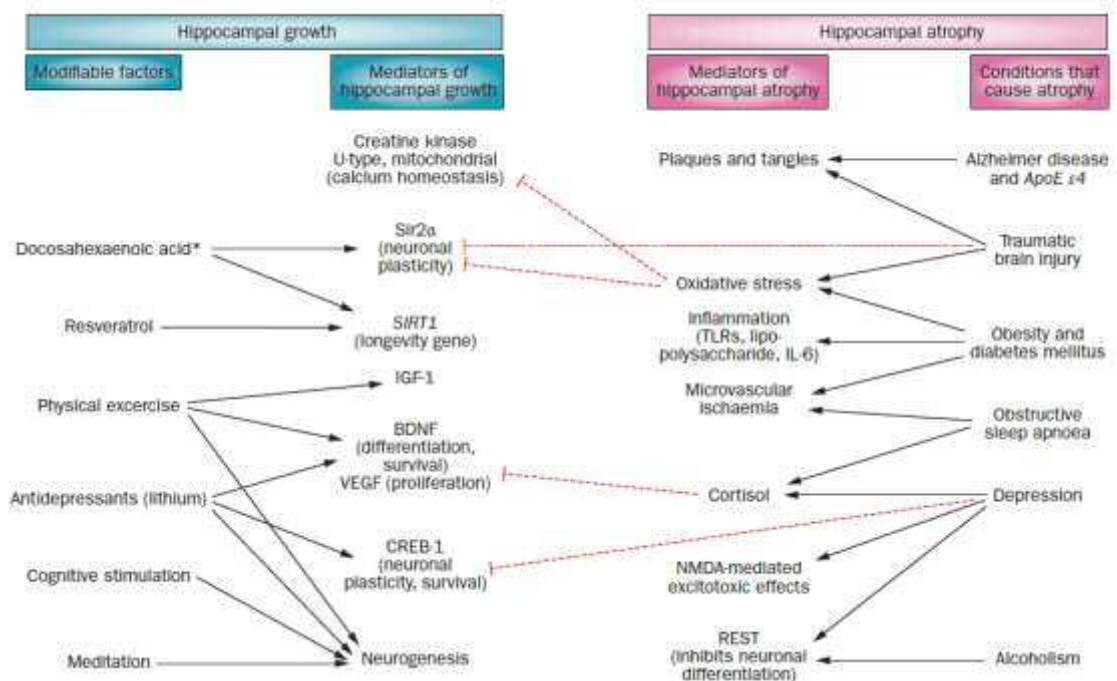

Figure 1-5. Pathways to hippocampal growth or atrophy, from Fotuhi et al., 2013, p.193.

Given the wide range of genetic and environmental influences on neural resource enhancement and depletion, focus is required in the context of a thesis. The current work hones in on one specific aspect of neural resources: structure of the

hippocampus and MTL (and associated real world memory function), and three specific factors likely to impact hippocampal structure prior to aging (as identified by the STAC-R model (see Figure 1-2) (Reuter-Lorenz & Park, 2014)): Physical activity as a potential neural resource enhancer, and genotype and mild traumatic brain injury as potential sources of neural resource depletion.

An aside: measuring brain structure with MRI

Magnetic resonance imaging (MRI) was introduced during the late 1970's , allowing for examination of brain neuroanatomy before post mortem and with increased differentiation of brain areas in comparison to previous structural brain scan methods (Lerch et al., 2017). With the structure and spatial organisation of the brain described as “physical manifestations of the information encoded in the genome, developmental history and experienced environment” (Lerch et al., 2017) (p. 317.), it is clear how MRI could play a key role in understanding the combined genetic and environmental influences on the brain and cognitive wellbeing. MRI involves the application of electromagnetic waves on hydrogen atoms within the brain (Lerch et al., 2017), which respond differently dependent on the chemical composition of the tissue (Kennedy, Makris, Herbert, Takahashi, & Jr, 2002). Resultant changes in the water molecules alignment to the MR's magnetic field build up a three-dimensional image of the brain, consisting of cubic voxels (3 dimensional pixels), that can be processed through a number of different methods (Alexander-Bloch, Giedd, & Bullmore, 2013). When focusing on particular neural structures, scans must be first registered to a common anatomical space using an average brain template or atlas (Alexander-Bloch et al., 2013). Following this segmentation process, volumes of regions and structures can be calculated by summing the properties of all voxels within the defined boundaries (Kennedy et al., 2002). Alternatively, surface area or cortical thickness measures can focus on measuring the boundaries separating grey and white matter or cerebrospinal fluid (Alexander-Bloch et al., 2013).

Genetics: role of BDNF genotype

According to the STAC-R model, one factor that has an especially powerful depletion effect on cognition is our genetic profile. One well-studied gene is *APOE*. Individuals carrying the *APOE* E4 allele are at increased risk of developing Alzheimer's and have a lower age of onset (Liu, Kanekiyo, Xu, Bu, & Bu, 2013). Even one copy of the allele, which is carried by roughly 20% of the population, substantially increases the risk of an Alzheimer's diagnosis in one's lifetime (Liu et al., 2013). The biological mechanisms underlying these observations are poorly understood but, consistent with the STAC-R model, there is evidence that *APOE* E4 has effects on brain structure and function that are not in themselves pathological, but appear to make the brain more susceptible to age-associated pathological mechanisms (Jagust & Mormino, 2011; Reinvang, Espeseth, & Westlye, 2013). For example, there is evidence that children and young adult E4 carriers have smaller hippocampal volumes and reduced MTL cortical thickness relative to non-carriers (O'Dwyer et al., 2012; Shaw et al., 2007).

However, separating the influence of genetics from the social and physical environment is a key challenge in the area, given substantial evidence for gene-environment interaction and gene-environment correlation effects on brain structure (Lerch et al., 2017). This is especially the case considering the complexity of brain structure and function, but also its ability to develop long term. Genetic effects may not be immediate but, for example, could predispose someone to a high stress response, resulting in a prolonged neural resource depletion over their life-time (Petkus et al., 2016), or poor recovery from environmental traumas such as mild traumatic brain injury (Cicchetti & Blender, 2006). This ongoing effect of genetics interacting with the environment again leads back to neuroplasticity.

Brain-derived neurotrophic factor (BDNF), the most abundant neurotrophin in the human brain, is robustly expressed in the hippocampus and surrounding cortex (Angelucci, Brenè, & Mathé, 2005; Huang & Reichardt, 2001) and is important in regulating synaptic plasticity as well as neurogenesis, neuronal survival, and dendritic growth (Dooley, Ganz, Cole, Crespi, & Bower, 2016; Laurent, Ejtehadi, Rezaei, Kehoe, & Mahmoudi, 2012; Notaras, Hill, & Buuse, 2015). In this sense, inadequate neurotrophic support could lead to inappropriate cortical circuitry and synaptic transmission in the

developing brain (see Figure 1-6), which could translate into a reduced ability to make adaptive changes throughout the lifespan (Notaras, Hill, & Buuse, 2015). In turn, this reduction in plasticity could underlie the variability in neural functioning related to the development of later life disorders, as suggested by the STAC-R model.

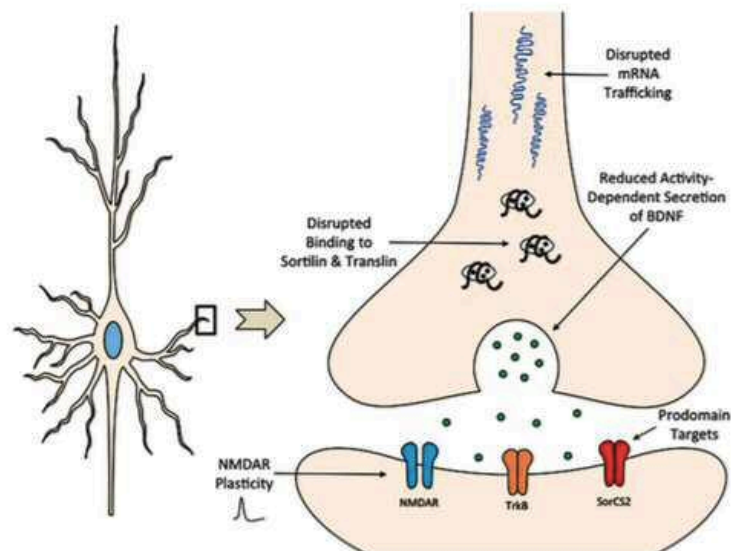

Figure 2. The molecular phenotype of the *BDNF* gene Val66Met polymorphism at the level of the synapse. The valine-to-methionine substitution at codon 66 of BDNF has been reported to disrupt dendritic BDNF mRNA trafficking, binding to the intracellular transport molecules, sortilin and translin, and activity-dependent secretion of BDNF. Altered NMDA receptor-mediated plasticity within the hippocampus and transmission in the infralimbic medial prefrontal cortex has also been reported, while the 66Met prodomain of BDNF may bind differentially to receptor targets such as SorCS2. BDNF, brain-derived neurotrophic factor; NMDA, N-methyl-D-aspartate.

Figure 1-6. Val66met phenotype at synapse level from Notaras et al., 2015, p.2

In this thesis, I will consider two potential sources of inter-individual differences in BDNF secretion: one genetic and one environmental. A common single-nucleotide polymorphism within the *BDNF* gene (rs6265) causes a valine (Val) to methionine (Met) substitution at codon 66 (Val66Met). Carriage of 1 or 2 Met alleles is associated with lower BDNF production (Egan et al., 2003). The *BDNF* gene Val66Met polymorphism is a genetic risk for anxiety and affective disorders such as post-traumatic stress disorder (PTSD) and major depression. The *BDNF* gene Val66Met polymorphism has also been linked to neuroplasticity, including recovery from brain trauma (Barbey et al., 2014; Hayes et al., 2017; Lamb et al., 2015; Lee, Baek, & Kim, 2015). These results point to a potential role of *BDNF* Val66Met in influencing the speed and severity with which neuropathology impedes normal cognitive functioning.

In the context of life-course cognition, one recent development has been the identification of a role for the *BDNF* Val66Met polymorphism in risk for late onset

Alzheimer disease AD. In a middle-aged cohort with Alzheimer's risk, carriage of the *BDNF* Met allele was associated with steeper decline in episodic memory over the course of around one decade (Boots et al., 2017). Similar to *APOE* E4 allele carriers, Met allele carriers have been shown to have reduced hippocampal volumes (Harrisberger et al., 2014). However, alternate findings (Jaworska, MacMaster, Foster, & Ramasubbu, 2016) have been documented, making the relationship between *BDNF* and brain structure unclear. The current literature is still conflicted on which variant of the gene acts as a positive protective factor for neural and cognitive health, suggests that complex interactions between age, sex, environmental factors, and other genetic variants may modify the effects of this variant on neural structure and cognitive function (S. N. Kim et al., 2013).

One major limitation of research to date has been a focus on regional analyses, clearly brain regions do not function in isolation, but as part of broader functional networks (Mesulam, 1990). In Chapter 2 of this thesis, I apply a novel approach called structural covariance to examine the influence of *BDNF* genotype on broader hippocampal 'connectivity' in a large sample of healthy young and early middle-aged adults – possibly allowing for identification of subtle neural variations potentially indicative of later cognitive health. This technique (Hayes, 2013) examines the extent to which brain regions co-vary in their morphological properties (volume, thickness) (see Chapter 2 for details) to address this limitation in the existing literature.

An important lifestyle factor that may impact *BDNF* levels and in turn MTL structure is physical activity. In rats, voluntary wheel running upregulates expression of *BDNF* and modulates plasticity in the hippocampus (Sleiman & Chao, 2015). Exercise-induced up regulation of *BDNF* expression in hippocampal neurons may promote synaptic remodelling, as voluntary running increases dendritic complexity and the number of dendritic spines in the hippocampus and surrounding cortex (Opendak & Gould, 2015). It may also influence exercise-induced angiogenesis and neurogenesis and has been shown to reverse memory function in aged rodents (Opendak & Gould, 2015). In humans *BDNF* genotype has been shown to interact with self-report physical activity to predict working memory (Erickson et al., 2013), to moderate the relationship between aerobic fitness and regional neural surface area (Herting, Keenan, & Nagel, 2016), to moderate the strength of association between lower levels of activity and cognitive

functioning (Kim et al., 2011), and to interact with physical activity as a predictor of episodic memory in older adults (Canivet et al., 2015). It appears that physical activity can influence BDNF function and, as this is a modifiable risk/benefit factor, is clearly a high priority for the development of interventions (Erickson et al., 2013).

Physical Activity Influences on Brain Structure in Humans

Physical activity is a “bodily activity that results in energy expenditure above resting levels” (Thomas, Dennis, Bandettini, & Johansen-Berg, 2012, p.1). Activity can be described as vigorous-intensity, such as sprinting or weight lifting, where energy is supplied by the anaerobic energy system. Moderate-intensity activities include walking or swimming and instead rely on energy supplied by the aerobic system. Low-intensity resistance, balance, and flexibility exercises also have neuro-motor importance. Seventy-plus years of animal studies supported the unique effects of enriched environments, including physical activities, on neurostructural development through multiple processes including increasing the rate of neurogenesis (Thomas et al., 2012).

Rodent and human imaging studies have demonstrated changes in the neural structure of primarily exercise-related areas such as the motor cortex and cerebellum, but also highlight regions within the hippocampus in particular (Thomas et al., 2012). The importance of the hippocampus in physical exercise may be due to not only its memory and learning functions but also in its involvement in stress regulation (Thomas et al., 2012). This is pertinent when considering that elevated cortisol levels, linked to stress, act as a key mechanism in diabetes (type 2) and depression/PTSD related hippocampal atrophy (Fotuhi et al., 2012). The impact of physical activity on life-span cognitive health frequently utilises potentially related disorders such as the latter identified diabetes and obesity. High BMI (body mass index) is linked with increased hippocampal atrophy and low total brain volume (Fotuhi et al., 2012).

Higher levels of fitness and increased physical activity in older adults has been linked to larger hippocampus and prefrontal cortex volume, greater functional connectivity, and improved executive functioning and memory (Erickson, Hillman, & Kramer, 2015). Recent work has aimed to look at physical activity effects in children beyond comparison with school grades, finding increased volume in the hippocampus, more efficient neural activity patterns, and improved episodic memory and executive

functioning in particular (Erickson et al., 2015). The number of minutes of aerobic exercise per week self-reported by adults between the ages of 18-45 has been shown to correlate with right hippocampal grey matter volume using voxel-based morphometry (Killgore et al., 2013). A study of older adults with no cognitive abnormalities found that higher fitness levels were associated with larger hippocampi (Fotuhi et al., 2012). Longer term cohort work with older participants (mean age 78), found the greater hippocampal volume was found only in those in the highest quartile for physical activity, based on the number of city blocks walked per week (K Erickson et al., 2010). Similar results were found in a study of participants with schizophrenia who took part in a randomized controlled trial of three times per week aerobic exercise. This resulted in an increase in hippocampal volume compared to a decrease in control non-exercising patients (Pajonk et al., 2010). These findings were replicated in healthy participants between the ages of 55-80 with normal cognition (K. I. Erickson et al., 2011).

A recent meta-analysis of 14 controlled aerobic exercise studies only found a significant effect on the left hippocampus volume, suggesting the potential for lateralised effects of some forms of physical activity (Firth et al., 2018). However, as one included study found increased left hippocampal volume following the exercise intervention was related to a *lower* cognitive performance, further work is needed to identify what relationship exists between exercise, hippocampal neural structure, and everyday cognitive function.

It is currently unclear how exercise-induced changes in levels of growth and neurotrophic factors relate to volumetric hippocampal changes in humans. In a one-year intervention study (Erickson et al., 2011), changes in serum BDNF were correlated with increases in hippocampal volume (exercise group only). As mentioned above, animal models show that angiogenesis/neurogenesis and structural remodelling can increase with an increase in physical activity (Thomas et al., 2012), however the specific mechanisms and forms of physical exercise which can result in this beneficial effect are still undetermined (Thomas et al., 2012). In Chapter 3 of this thesis, I report a new study of the relation between physical activity and both everyday memory function and hippocampal volumes.

Of note when taking a health neuroscience and multi-factorial approach, is how an individual's behaviour could result in a mix of both positive (neutrally enriching) and negative (neutrally depleting) effects across the life-span, with the potential for complex interactions between outcomes. Whilst physical activity is evidenced as beneficial for neurogenesis and cognition, particularly for hippocampal/ MTL function, some forms and aspects of physical activity could be potentially harmful towards life-time cognitive wellbeing.

Mild traumatic brain injury (mTBI) has been identified as a possible risk during participation in contact sports such as rugby, horse riding, martial arts, and hockey (Perez-Polo et al., 2013). These sports related concussions (SRC), whilst typically only presenting with short term symptoms (Doolan et al., 2012), have been linked to remote later life cognitive decline and abnormal neural pathology (Dewitt et al., 2013). Such injuries are particularly relevant in the context of the present work as the hippocampus is particularly vulnerable to even a single episode of mTBI (Fotuhi et al., 2012). Reduced hippocampal volume and relational memory deficits following a history of mTBI (Monti et al., 2013) and prominent microstructural white matter damage in both the frontal (McKee et al., 2013) and medial temporal lobes (e.g. the fornix) (Niogi et al., 2008), suggests combined impairment in both memory and executive functioning following mild brain injury. A history of mild TBI is also linked to hippocampal atrophy later in life (Monti et al., 2013) and animal models of mTBI indicate that hippocampal neurogenesis is impaired (reviewed in Monti et al., 2013).

Increased public and research interest in the risk of concussion in sport led to a response from the International rugby board suggesting both positive and negative effects of increased media and public attention (Raftery, 2014). Whilst increased public awareness has been described as beneficial, there is the risk of developing "evidence deficient risk management strategies" (Raftery, 2014, p1) and undermining the clear health benefits of sports. Research has shown public misperception of sports risks (Quarrie, Brooks, Burger, Hume, & Jackson, 2017), and there are calls for scientists and medical doctors to "reclaim clinical decision making from the realm of media-driven and often frenzied public opinion" (Patricios & Kemp, 2013, p.4). It appears that participation in youth football in America is declining (Murphy, Askew, & Sumner, 2017), with authors crediting risk of head injuries as the leading cause. Future research

may benefit from not only investigating the neurobiological risk itself; but the more direct transfer of knowledge and safety attitudes to the public. Such work can guide policy and interventions with the aim to optimise cognitive health and development and reduce potential for decline later in life. This forms the second part of this thesis.

Attitudes and Knowledge

Most empirical research on health-related behaviour from a social cognition perspective tends to emphasise attitudinal determinants. Attitudes act as a personal psychological tendency to evaluate an attitude object as either positive or negative for the self (Eagly & Chaiken, 2007), based on an individual's experiences and knowledge. Whilst often overlooked in sports medicine research (McGlashan & Finch, 2010), they are especially appropriate when considering how an individual may process the array of potential positive and negative influential factors relating to their health.

Attitude research has demonstrated how certain attitudes can impact on behaviour related to specific risks, with the potential for inappropriate safety and wellbeing actions (Kerr et al., 2014). This is especially the case when mapped within a multi-level model predicting behaviour through a range of related factors such as peer influence (Kroshus, Garnett, Hawrilenko, Baugh, & Calzo, 2015) and knowledge (Kerr et al., 2014). This demonstrates how findings such as poor knowledge of concussion symptoms and recovery in the UK public (Weber & Edwards, 2012) could interact with attitudes for unfavourable outcomes

The importance of parent attitudes and knowledge is highly relevant considering a life-course model of cognitive health, in which development up to at least adulthood is tied to parental decision-making. Yet parents are often overlooked in models focusing on coaches or medical staff (Sullivan et al., 2009), and studies have found they present with overall low awareness of concussion as a risk in sports, and what management action should be taken (Bloodgood et al., 2013; Sullivan et al., 2009; Kerr et al., 2014). Work by Fedor et al. (2016) on parental attitudes, only applied to American football, and there is a need for consideration of other sports such as in my current work. If a lack of correct knowledge and inappropriate attitude formation takes place, symptoms

could be missed resulting in poor outcome following concussion, or withdrawal of children from certain or all sports.

Current Work

The current work is the result of an integrated PhD studentship funded by the ESRC. The project was initially entitled 'Unifying Social and Biological Approaches to Early Detection of Dementia' and allowed for an extra year to explore different specialisms and methodological approaches. Inter-disciplinary support was available across Schools in Cardiff University, Bangor University, and the Institute of Neurology in London. Areas represented included Cognitive Neuroscience, Social Psychology, Brain Imaging Methods, Sociology of Biomedical Science and Bioethics, Genetics, and Clinical Psychology. Five studentships were available with the same theme, and ultimately formed a lab-group within Cardiff University Psychology department. This allowed levels of collaboration for larger data sets and the collection of more time-consuming and expensive data such as genetic-testing and neuroimaging. However, this also led to outside influence in design aspects of the studies and restrictions to control of measures taken due to practicality considerations, caution around data division and multiple comparisons, and fatigue effects in participants undergoing multiple assessments and neuroimaging sessions. The ESRC also provided an internship opportunity within the Welsh Local Government Association. Influence from this experience is demonstrated with consideration of impact within a Welsh context throughout and within the General Discussion chapter.

A key aim of the studentship was to bring together biological and social approaches, allowing for a more in-depth and multi-faceted understanding of the complex issues of cognitive health and neurodegeneration. This is particularly relevant in the current work which looks at long-term cognitive health in a multi-factor model through which many very different and interacting factors could have an influence on an individual's outcome. More specifically this research aims to bring together the field of health psychology and the emerging field of health neuroscience (Figure 1-1), attempting to build a greater understanding of cognitive health across a life-span and with a view to research that has wider public impact. Health has been described as "a consequence of multiple determinants operating in nested genetic, biological, behavioural, social, and

economic contexts that change as a person develops” (p.433 Halfon & Hochstein, 2002), with any personal developments in one’s health being “an adaptive process composed of multiple transactions between these contexts and the biobehavioural regulatory systems that define human functions” (p.433 (Halfon & Hochstein, 2002). In health research, successful impact arguably relies on both clearer biological and social understanding of these nested health processes, and awareness of what and how risks and benefits can be communicated to the public and professionals. Consider, for example, the life-course differences in health between females and males. Biological explanations such as hormone variation, evolutionary selection, and mental health-immune system interactions have been put forward (Rieker & Bird, 2005). However, social explanations can interact with the above, and emphasise the role of environmental factors such as social position, common employment risks, and coping resources. The authors of the review describe the need for integrative work, despite the complexity of designing such studies, and practical concerns regarding funding, publishing, and cross-department collaboration (Rieker & Bird, 2005). Without an understanding of these multiple varied interacting biological and environmental factors, there cannot be a solid understanding of this gender health difference, or how it can be tackled through interventions and policy – seeking optimum health outcomes for all.

As such, this thesis is structured in two parts – highlighting the benefits of integrated work that includes environmental and biological approaches to health – and aims to guide future health communication and impact. Part 1 focuses on health neuroscience, investigating two key factors that impact hippocampal structure and episodic memory within the STAC-R framework; one genetic and one environmental (physical activity). Part 2 then shifts to a social focus on health psychology, aiming to understand factors that influence attitudes towards physical activities with potential risks (concussion, dementia), with a view to ultimately framing policy and interventions to optimise cognitive development and minimise cognitive decline in late-life. This allows for integration between social and biological influences on health in Part 1. Additionally, it integrates biological research and social psychology for communication and impact purposes in Part 2.

Part 1

As mentioned above, the first part of this thesis looks at one genetic and one environmental factor that may influence BDNF levels and neuroplasticity.

Chapter 2 is a large-scale study of the impact of the *BDNF* val66met polymorphism on hippocampal and MTL structure and structural covariance in a sample of young and midlife adults. This study aims to clarify the relationship between *BDNF* genotype and hippocampal and MTL structure and provide novel evidence for a role for *BDNF* genotype in influencing the structural covariance of the hippocampus. This is a secondary analysis of an existing multi-study data-set within Cardiff University as part of the '1000 Brains' project. As this was a large project, a broad range of data was available, and it allowed for a higher level of control over the current study design, but no control over methodology. The neuroimaging pipeline is standardised up to post-processing.

Chapter 3 examines the relation between physical activity and hippocampal / MTL structure and everyday memory function in healthy young adults, to examine whether, even in early adulthood with no diagnosed cognitive decline, increased physical activity is linked to increased hippocampal volumes and better real-world memory functioning. This study was developed from a larger ongoing project including collaboration with other ESRC integrated studentships. Control over the cognitive assessments and physical activity measure was possible, however there was limited input possible regarding the neuroimaging methodology and post-processing.

Part 1 supported a multi-factor model of cognitive health and highlighted the need for knowledge transfer to aid the public and professionals in seeking individual's optimum health. With multiple environmental and genetic variables playing a role, Part 2 importantly looks at physical activity as a related social psychology example of a factor which could offer both health benefits and potential health risks.

Part 2

The second part moves into the realm of health psychology, with consideration of the role of knowledge and attitudes in the context of parent decision making in relation to

concussion and sport. This work ultimately aims to inform future research and interventions initiatives.

Chapter 4 provides an introduction to the current literature on attitudes to sports related concussion, discussing relevant models of attitude formation and its importance in three key areas; prevention, management, and symptomology. It highlights multi-factor models of attitude formation, the important role of parents in child health behaviour, and the current weakness in literature to form a predictive relationship between attitudes and behaviours.

Chapter 5 follows on from the narrative review, aiming to extend current insight in to parent's attitudes towards and knowledge of sports related concussion. In particular, looking at behaviour related attitudes to what contact sports parents would allow their children to participate in, and what factors could influence this decision making. The survey will take advantage of the benefits of both quantitative and qualitative methods and allow for control over all aspects of study design.

A combined neural and social approach to a life course model of late life cognitive health will ultimately enable a greater translation of scientific research into public understanding and health policy. Health Neuroscience can inform what effects genes and experience can have on neural structure and cognition across the life course, whilst health psychology can investigate how these risks/benefits may be understood by the public, and ultimately inform strategies, policies, and interventions, to optimize cognitive development and minimize cognitive decline in late-life.

Part 1: Health Neuroscience

2. Brain-derived neurotrophic factor (*BDNF*) Val66Met polymorphism linked to brain structure and brain structure covariance in healthy adults

Introduction

Modern advances in health care have led to a necessary increase in older age cognitive health research (Park & Festini, 2016). Social and biological work suggests cognitive health should be considered developmentally, determined by an individual's resilience (Jagust, 2016; Rutter, 2006). This refers to a person's ability to recover from an acute or chronic traumatic experience, whether physical or mental. Cognitive resilience, whilst difficult to measure, could impact the development of dementia (Mok et al., 2017) or psychiatric disorders such as post-traumatic stress disorder (Rutter, 2006). Initial research in resilience focused on environmental factors, whereas models now consider the influence of genetics and gene-environment correlations and interactions (Cicchetti & Blender, 2006). As discussed in the introduction to this thesis, the enrichment and depletion of neural resources throughout an individual's lifespan may be determined in part by the initial and on-going influences of their genetic make-up in interaction with the environment (Reuter-Lorenz & Park, 2014; Jagust 2016). Genetic factors could influence predisposition towards risk avoidance or use of various coping strategies, and interact with environmental traumas differently over time (Cicchetti & Blender, 2006). In particular, genes involved in neuroplasticity processes could account for lifespan brain organisation changes and recovery at both a neural and behavioural level (Cicchetti & Blender, 2006).

A protein shown to be critical for neuroplasticity processes, neuronal protection, and synaptic growth, as well as stress reactivity, is brain-derived neurotrophic factor (*BDNF*) (Dooley et al., 2016; Laurent et al., 2012). Animal studies show that *BDNF* is highly expressed in hippocampus, amygdala, and other medial temporal cortex structures, and alterations in *BDNF* signalling have been linked to emotional disorders such as schizophrenia and depression (Angelucci et al., 2005). In addition, *BDNF* signalling may be protective against the negative effects of processes that are typically associated with aging and neurodegenerative diseases, such as inflammation (Dooley

et al., 2016), and amyloid beta plaque build-up in the brain (Laurent et al., 2012). More generally, BDNF has a primary role in neuronal development and differentiation and plasticity in both the developing and adult brain (Dooley et al., 2016). It is its role in advance of impairment or disease that is of particular interest as a factor in a life course model of neural resilience and health.

A common single-nucleotide polymorphism within the *BDNF* gene (rs6265) causes a valine (Val) to methionine (Met) substitution at codon 66 (Val66Met). Carriage of 1 or 2 Met alleles is associated with lower BDNF production (Egan et al., 2003). In particular, an individual's val66met genotype has been linked to risk of mBTI (Hayes et al., 2017), and recovery from traumas such as mBTI and neglect (Barbey et al., 2014; Caldwell et al., 2013). It has also been linked to poor episodic memory (Voineskos et al., 2011; Ward et al., 2014; Kennedy et al., 2015), and risk of neurodegeneration and cognitive decline, including Alzheimer's disease later in life (Gomar et al., 2016; Lee, Baek, & Kim, 2015; Reinvang et al., 2010; Boots et al., 2017).

In healthy children and adults, this polymorphism has been studied for its links to brain structure and function, especially of the hippocampus and related medial temporal lobe structures (Egan et al., 2003; Lamb et al., 2015; Reinvang et al., 2010; Takahashi et al., 2008). Although findings have been mixed, a recent meta-analysis found that there was a significant effect of Met allele on hippocampal volume (Met smaller than Val allele), however the effect size was small and published studies were often underpowered (Harrisberger et al., 2014). In addition, in adults with amnesic mild cognitive impairment and high levels of amyloid beta accumulation, Met carriers presented with lower hippocampal volumes and poorer episodic memory scores (Lim et al., 2014), as well as enhanced cognitive decline (Boots et al., 2017). Similar reduced hippocampal volumes have also be linked to poor episodic memory in healthy adult Met individuals (Jensen, 2013; A. Kim et al., 2016), speaking to the functional relevance of *BDNF* gene influence on hippocampal structure even prior to disease.

A drawback to most previous studies that focused on regional volumes of the hippocampus alone, is that brain regions do not develop or function in isolation. Episodic memory formation, for example, relies on integration of information across the hippocampus, medial temporal lobe cortex, and medial parietal and prefrontal cortices (Barker et al., 2017). The hippocampus also works with the prefrontal cortex,

amygdala, and dentate gyrus in emotion and fear learning (Izquierdo, Furini, & Myskiw, 2016).

Functional connectivity fMRI methods have been used to identify and assess networked brain regions such as the default mode network (DMN) in relation to *BDNF* genotype. The DMN, in particular its posterior component, has been implicated in episodic memory, environmental learning, and planning future behaviour (Koch et al., 2012). According to the PMAT (posterior medial and anterior temporal) framework (Ritchey, Libby, & Ranganath, 2015), posterior DMN regions such as the parahippocampus, posterior cingulate, and precuneus form a network critical to episodic and autobiographical memory processes; whereas anterior system regions such as the anterior ventral temporal cortex, amygdala, and lateral orbitofrontal cortex, could function together in semantic and affective processing, enhancing memory for emotionally salient information and contexts (Ritchey et al., 2015). The hippocampus is put forward as a likely site of integration for these systems (Ritchey et al., 2015), and as such highlights the potential for *BDNF* or val66met to effect combined emotional and memory processes. Such cortical overlap involved in the processing of contextual affective associations has been described as a core component in human thought (Bar, Elissa Aminoff, Malia Mason, 2007). Val66met could influence an individual's lifetime psychiatric health, in addition to memory functioning, due to differences in a wider set of cognitive and emotional processes. In the only study of *BDNF* influences on the DMN, Child Val homozygotes demonstrated greater functional connectivity within and beyond the whole DMN network, and higher resting functional connectivity in the left hippocampus, than Met carriers or homozygotes (Thomason, Yoo, Glover, & Gotlib, 2009).

A role for the amygdala is suggested, as the Val66met polymorphism as mentioned above, has also been found as a risk for increased anxiety traits (Jensen, 2013; Minelli et al., 2011), depression (Notaras, Hill, & van den Buuse, 2015), post-traumatic stress disorder (PTSD) (Notaras, Hill, & van den Buuse, 2015), and stress reactivity (Colzato, Van der Does, Kouwenhoven, Elzinga, & Hommel, 2011). Thus, the *BDNF* Val66Met polymorphism appears to be a shared risk factor for both mood disorder/chronic stress and late life neurodegeneration.

As suggested by the PMAT framework, BDNF could influence the relation between emotion and memory networks, explaining the comorbidity between stress disorders and memory impairment. In addition to earlier described hippocampal structures, the brain areas implicated in emotion and BDNF studies reflect regions typically involved in emotion and fear learning processes (Notaras, Hill, & van den Buuse, 2015). Reduced grey matter volumes have been found in Met participant middle frontal gyri (Ide et al., 2015), amygdala (Montag, Weber, Fliessbach, Elger, & Reuter, 2009), superior frontal gyri (Notaras, Hill, & van den Buuse, 2015), and prefrontal cortices (Legge et al., 2015). Major depressive disorder patients have presented with parahippocampal volume differences related to the Met allele (Montag et al., 2009), although cortical thickness analysis of the same region in schizophrenia patients found a lack of differences compared to healthy siblings and controls (Goldman et al., 2009) – again suggesting a mixed picture.

Whilst not all studies have found links between emotional pathology, val66met genotype, and hippocampus and amygdala structure (Jaworska et al., 2016), the literature is also conflicted on whether it is the Val or Met allele that could serve as the “risk” allele. This may be due to the changing nature of BDNF’s function across the lifespan or result from gene-environment interactions. Healthy adults with the Met/Met genotype demonstrate a higher stress and depression response (Colzato et al., 2011; Kim et al., 2013). Kim et al. (2013) suggest val66met is associated with an individual’s resilience to emotionally stressful events. Rather than *BDNF* having a set effect on a person’s emotional state, the Val66Met gene could instead influence development and recovery throughout their life. This makes particular sense when considering the neuroplasticity functions of BDNF (Chattarji, Tomar, Suvrathan, Ghosh, & Rahman, 2015). Caldwell et al. (2013) found the supposed reduced level of neuroplasticity with the Met allele acts as a protection from childhood trauma, influencing the development of coping mechanisms in relation to depressive disorder. Instead they and Hosang, Shiles, Tansey, McGuffin, and Uher (2014) put forward a model of interactions between age, severity of trauma, genotype, coping strategy, and depressive state. Factors such as these may be responsible for inconsistent findings, in addition to sample differences such as age (Borba et al., 2016). Another related possibility, consistent with the PMAT framework, is that *BDNF* genotype may have

competing influences in different memory networks – for example facilitating fear and stress related memory systems to deal with threat (anterior system) but impairing detailed episodic memories (posterior system). Such differences may confer resilience in some circumstances at the cost of risk to late life cognition.

This current study aims to add to the published work on the relation between the *BDNF* val66met polymorphism and brain structure by utilising a large, heterogeneous healthy adult sample, and focusing on the frequently highlighted hippocampus and parahippocampus, in addition to the amygdala as a key node in the PMAT system (see Figure 2-1) (Ritchey et al., 2015). As mentioned above, a drawback of regional analyses is that brain regions do not develop or function in isolation. Therefore, in addition to MRI-derived measures of regional cortical thickness and volume, I will use structural covariance patterns to probe the relationship between brain regions. Structural covariance is the statistical association, across a population, of pairs of brain regions in their anatomical properties (typically volume or cortical thickness, but more recently surface area or diffusion-weighted imaging) (Alexander-Bloch et al., 2013; Evans, 2013). The technique involves post-processing of structural MRI, calculating features such as thickness and volume of brain regions or structures, and considering their similarity independently of any correlation attributable to overall brain size (Alexander-Bloch et al., 2013). Whole-brain correlation matrices can be produced, or smaller co-variance tables can be created by focusing on specific regions. Whilst the underlying mechanisms of structural covariation between areas is still in need of further investigation, and results are likely to indicate different developmental stages (Evans, 2013), the approach can lead to more effective understanding of variation, especially in the context of multiple impacting factors and wider functional networks (Alexander-Bloch et al., 2013). For example, individuals with greater cortical thickness of the language-related Broca's area of the inferior frontal cortex typically also have greater thickness of another language-related area (Wernicke's) of the superior temporal cortex (Evans, 2013).

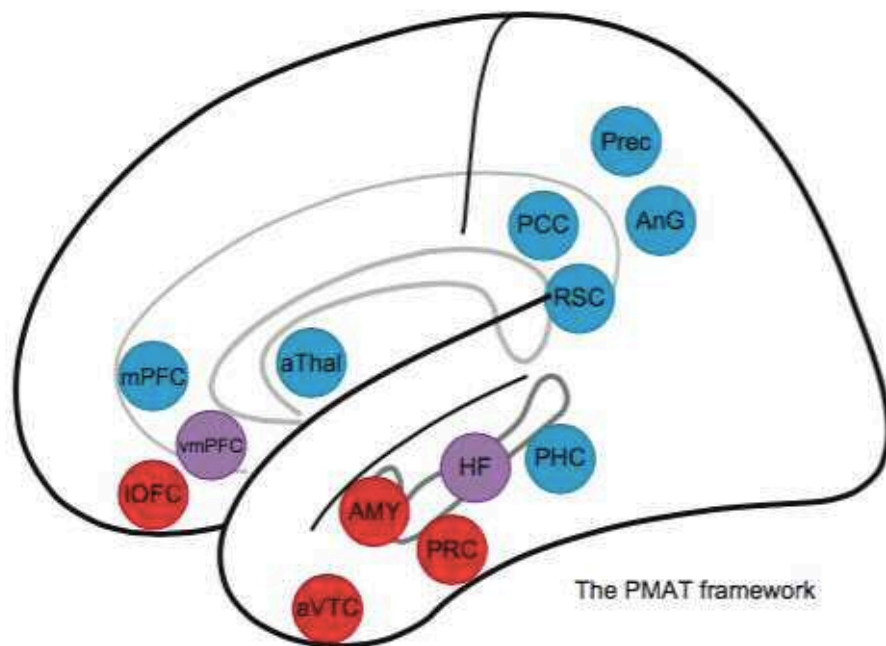

FIGURE 1

The PMAT framework. Regions of the PM system include the PHC, RSC, posterior cingulate (PCC), angular gyrus (AnG), precuneus (Prec), anterior thalamus and mammillary bodies (aThal), and medial prefrontal cortex (mPFC). Regions of the AT system include the PRC, anterior ventral temporal cortex (aVTC), amygdala (AMY), and lateral orbitofrontal cortex (IOFC). Possible sites of integration include the hippocampal formation (HF) and ventromedial prefrontal cortex (vmPFC).

Figure 2-1. The PMAT framework from Ritchey et al. (2015) p.46

Such structural covariance may reflect a combination of genetic predisposition (linked to coordinated neurodevelopment) and lifetime influences on neural plasticity (Evans, 2013). Structural covariance is therefore especially pertinent when considering the potential life time effects of *BDNF* val66met genotype. Analysis of volumetric, cortical thickness, and structural covariance data, will also examine other key factors that could influence the link between *BDNF* genotype and brain structure. Both gender (Li et al., 2017) and age (Voineskos et al., 2011) have been shown to affect the relationship between brain structure and genotype. For example Li et al. (2017) found the significant link between the presence of a Met allele and Alzheimer’s disease or *BDNF* secretion was only found in female participants. Based on the findings outlined above, I tested for effects of *BDNF* genotype on hippocampal and amygdala volumes, parahippocampal cortical thickness, and – for the first time – on the structural covariation between hippocampal and amygdala volumes and regional cortical

thicknesses. Genotype differences in structural covariance were tested for using regression-based statistical moderation analyses in the framework of Hayes' PROCESS tool (Hayes, 2013).

Methods and materials

Participants

Four hundred and ten healthy participants (276 female, 134 male, range= 18-71 years, $M=26$, $SD=8.5$) were recruited through Cardiff University as part of a multi-study project called '1000 Brains'. The sample included university students, staff, and members of the public. Participants were screened and excluded for a history of psychiatric disorders, psychotropic medication, neurological/chronic medical conditions, and alcohol/substance misuse. The study was approved by Cardiff University School of Psychology Research Ethics Committee, and all participants gave written informed consent.

Genotyping

Genomic DNA was obtained through saliva, using the method described in (Lancaster, Foley, Tansey, Linden, & Caseras, 2016) (Caseras, Tansey, Foley, & Linden, 2015), with Oragene saliva kits. The *BDNF* 196-G>A (rs6265) polymorphism (val66met) was genotyped using custom SNP genotyping arrays from Illumina (Illumina, Inc., San Diego, CA). Participants were excluded for ambiguous sex, genotyping completeness <97%, and SNPs were excluded where the minor allele frequency was <1%. Three hundred and eighty-five participants were successfully genotyped, with 248 Val/Val, 125 Met/Val, and 12 Met/Met 137 Met. Distribution was near expected values following a Hardy-Weinberg Equilibrium analysis for two alleles (<https://www.easycalculation.com/health/hardy-weinberg-equilibrium-calculator.php>) ($\chi^2=.6226$).

Neuroimaging

Structural MRI imaging data were acquired using a 3T GE HDx system at Cardiff University Brain Research Imaging Centre (CUBRIC), High-resolution, T1-weighted anatomical images were collected using a three-dimensional fast spoiled gradient echo

(FSPGR) sequence comprising 178 axial slices. The parameters were as follows: TR = 7.9ms, TE= 3ms, flip angle 20 degrees, FOV=256x256x176mm, 1.0mm slice thickness.

Image Processing

A publicly available protocol for region of interest (ROI)-based segmentation (<http://enigma.usc.edu/> (Stein et al., 2012)) previously described by (Lancaster et al., 2016) (Caseras et al., 2015) was utilised. Hippocampal and amygdala ROI volumes were obtained using FreeSurfer software (<http://surfer.nmr.mgh.harvard.edu>), and values excluded when segmentation did not pass blind quality control inspection. Details of the segmentation process are available online (<http://freesurfer.net/fswiki/FreeSurferMethodsCitation>). Cortical ROIs were also segmented via FreeSurfer thickness values exported using Matlab (The MathWorks Inc., Natick, MA, 2000), after undergoing a blind quality control process. Images were inspected by eye, and data excluded for poorly segmented cortical regions, with whole subjects removed if poorly segmented. Total intracranial volume (ICV) was also calculated. Left and right hemisphere volume and cortical thickness values were averaged prior to analyses.

Statistical Analyses

ROI volumes included in analyses were the hippocampus and amygdala. They were inputted in to SPSS (<https://www.ibm.com/analytics/data-science/predictive-analytics/spss-statistical-software>) for ANOVA analysis of genotype effect on volumes. A normal distribution was determined, and the dataset also underwent a split by gender for some analyses. All regional volume analyses controlled for gender, age, and total ICV.

Cortical thickness measures were extracted for the parahippocampus. Again, normal distributions were confirmed, outliers of more than 2SD removed, and analyses controlled for gender and age. ICV was not controlled for as a regional cortical thickness is independent of total ICV (Westman, Aguilar, Muehlboeck, & Simmons, 2013). The datafile was later split for gender analyses.

Both volume and thickness data underwent further analyses using Hayes' (2013) SPSS PROCESS extension (<http://www.processmacro.org/index.html>). Moderated regression

analyses using Model 1 (see Appendix A) was carried out with Genotype group as the moderator and age, gender, ICV as covariates.

Participants were coded in SPSS as genotype group Val (Val/Val) or Met (Met/Met or Val/Met). The Met carriers (Val/Met) and Met homozygotes (Met/Met) were merged in to one group (dominant design) due to the expected low number of Met homozygotes in the sample. Family-wise error correction using the Bonferroni technique was used as appropriate.

Results

Genotype and effects on hippocampal volume

Bilaterally-averaged hippocampal volume was higher in Met ($M=4441.144 \text{ mm}^3$, $SD=396.710 \text{ mm}^3$) than Val participants ($M=4435.272 \text{ mm}^3$ $SD= 420.810 \text{ mm}^3$). However, no significant relation was seen between the volume of the hippocampus (averaged bilaterally) and genotype, controlling for gender, age, and ICV ($F(1,359)=.427$, $p=.514$, $PES=.001$ $OP=.100$). Neither males ($F(1,111)=.213$, $p=.645$, $PES=.002$, $OP=.074$) nor females ($F(1,240)=.230$, $p=.632$, $PES=.001$, $OP=.076$) demonstrated a significant effect of genotype when the analysis was carried out between groups. NB for this analysis, one case (Case 180) was removed as an outlier.

Descriptives show higher volumes of the left and right hippocampus (Left $M= 4697.100 \text{ mm}^3$, Right $M= 4668.100 \text{ mm}^3$) in Val than Met participants (Left $M= 4087.166 \text{ mm}^3$, Right $M= 4613.433 \text{ mm}^3$).

Higher volumes of the left and right amygdala (Left $M= 1434.000 \text{ mm}^3$, $SD= 39.377 \text{ mm}^3$, Right $M= 1555.766 \text{ mm}^3$, $SD= 303.558 \text{ mm}^3$) are found in Met compared to Val participants (Left $M= 1328.600 \text{ mm}^3$, Right $M = 1419.800 \text{ mm}^3$). However there was no significant relation between amygdala (bilaterally averaged) volume and genotype, controlling for ICV ($F(1,364)=.256$, $p=.613$).

Genotype effects on parahippocampal cortical thickness

Three hundred and sixty-three participants were divided in to VAL (val/val genotype) ($n=236$) or MET (val/met or met/met genotype) ($n=127$) groups. One case (Case 189) was removed as an outlier over 2SD from this analysis (but had little effect on the

trimmed mean). Average PHC thicknesses were calculated by averaging bilaterally. Cortical thickness of the parahippocampus was significantly higher in MET participants (M=2.853mm), SD=0.197mm) compared to VAL participants (M=2.801mm, SD=0.194mm) ($F(3,360)= 3.645, p=.013, PES= 0.29, OP= .796$ (see Figure 2-2). Age and gender were included as covariates in this analysis.

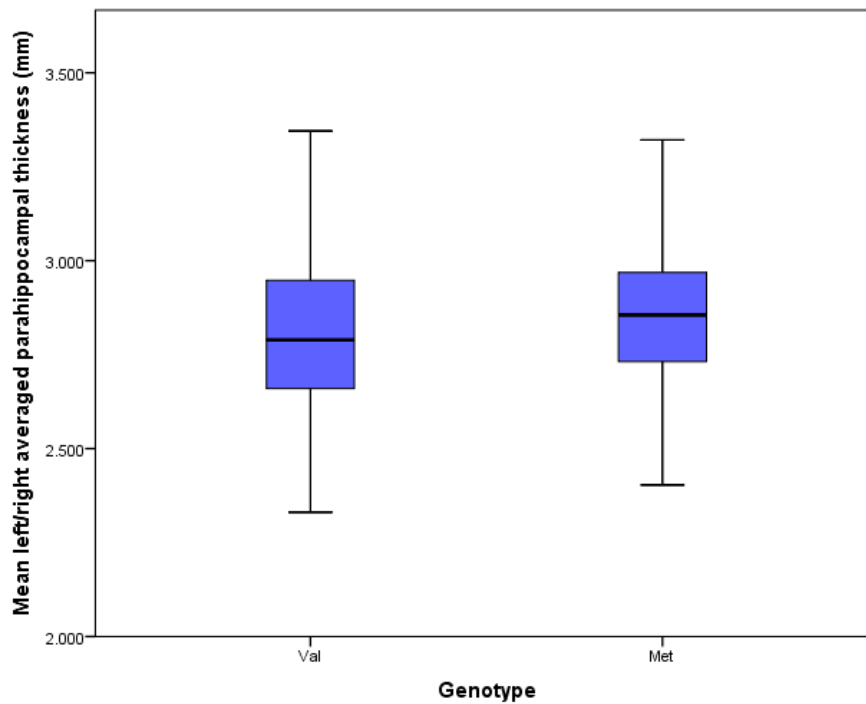

Figure 2-2. Mean parahippocampal cortical thickness for VAL and MET participant groups, controlling for age and gender.

Gender effects on the genotype and bilaterally averaged parahippocampus relationship were tested through univariate analysis of variance with age included as a covariate. Participants were split by gender for between-subjects effects analysis. Only Males demonstrated a significant link between genotype and parahippocampal thickness $F(1,114)=4.848, p=.030$ ($PES=.042, OP= .597$, surviving Bonferonni correction. MET males presented with increased parahippocampal cortical thickness (M=2.900, SE= .032) than VAL males (M=2.813, SD= .023) Females did not show this significant difference, $F(1,244)=2.564, p=.111$ ($PES= .010, OP=.358$).

Structural Covariance

A moderated regression between bilaterally averaged hippocampus and amygdala volumes, controlling for age, gender and ICV was performed to assess structural covariance related to genotype. A trend-level but non-significant interaction effect was

found $t(6,348) = -1.6689$, $p = .0960$. All control variables were significant: Age $t(6,348) = -2.1295$, $p = .0339$, Gender $t(6,348) = -2.2322$, $p = .0262$, ICV $t(6,348) = 6.4375$, $p = .000$.

Given that hippocampal-amygdala connections are entirely ipsilateral (Pikkarainen, Rönkkö, Savander, Insausti, & Pitkänen, 1999), the hippocampus and amygdala were further analysed for left and right hemispheres separately, and moderated regression analyses again carried out, controlling for age, gender, and ICV. Genotype significantly influenced the structural covariance between the left hippocampus and left amygdala $F(6,355) = -2.8044$, $p = .0053$ (surviving Bonferroni correction for multiple comparisons) such that the correlation between left hippocampus and left amygdala volumes was significantly greater in Met allele carriers (see Figure 2-3). There was no significant moderating effect of genotype on structural covariance between right amygdala and right hippocampus $t(6,363) = .0044$, $p = .9965$.

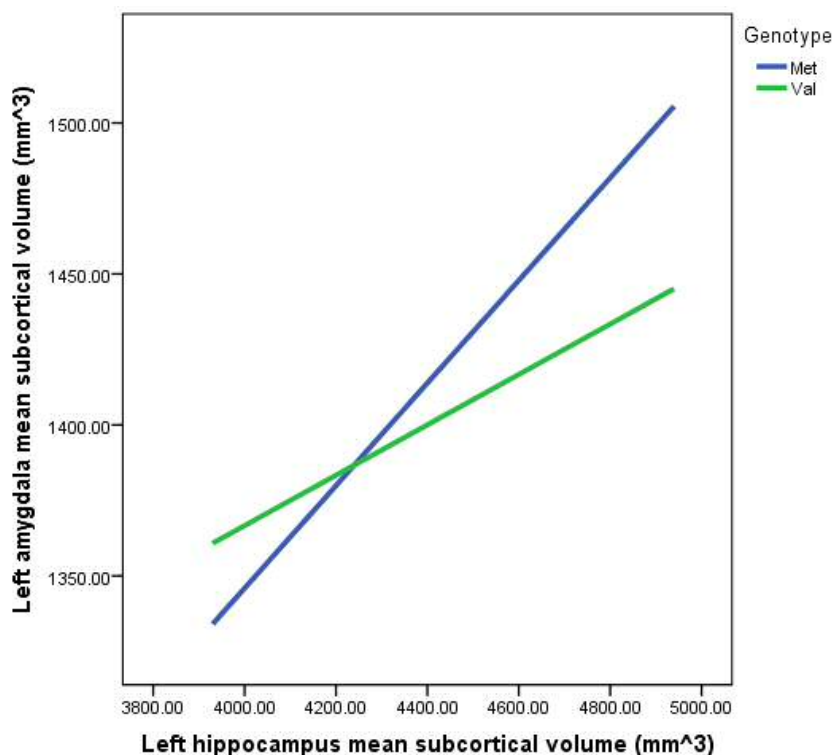

Figure 2-3. Mean left hippocampus and left amygdala subcortical volume structural covariance as significantly moderated by genotype group, controlled for age, gender, and ICV.

Supplemental Analysis of Age-Related Effects

Age group effects were tested by using a median split to create Younger (n=173) and Older (n= 190) groups. Age Group effects were tested with univariate analysis of variance, with gender included as a covariate. No significant interaction between Age Group and Genotype on Bilaterally Averaged parahippocampal cortical thickness was found $F(1,358)=.513$, $p=.474$. No significant interaction between Age Group and Genotype on bilateral average hippocampal volume, controlling for ICV, was found $F(1,355)=.002$, $p=.963$. Lastly, no significant interaction between Age Group and Genotype on bilateral average amygdala volume, controlling for ICV, was found $F(1,357)=.170$, $p=.680$.

Discussion

I aimed to replicate and extend previous findings on the relationship between *BDNF* val66met genotype and hippocampus, amygdala, and parahippocampal structure, through; (a) MRI-based measurement of volume and cortical thickness in a large sample of healthy adults and (b) the novel application of structural covariance analysis (Evan 2013, Alexander-Bloch et al., 2013), to examine if *BDNF* genotype influenced the correlation between hippocampal volumes and structure of the amygdala, a critical node of extended hippocampus networks (Ranganath & Ritchey, 2012).

Genotype influences on regional brain structure

Hippocampal volume, whilst on average higher in Met participants, did not significantly differ as a function of *BDNF* val66met genotype. When analysed separately, neither males or females demonstrated an effect of genotype on hippocampal volumes. Nor did age moderate any effect of genotype on hippocampal volume. This does not replicate previous findings, with studies suggesting lower hippocampal volumes in Met individuals (Jensen, 2013; A. Kim et al., 2016; Mather et al., 2015). The literature, is however, mixed with other recent reports of null effects (Kim et al., 2016). An earlier meta-analysis found that any effect of *BDNF* val66met genotype is likely to be small and that studies are often underpowered (Harrisberger et al., 2014). The current work was able to utilise a relatively large participant sample on the same MRI scanner, using a well-validated analysis pipeline, and yet failed to find evidence for a link between *BDNF* genotype and hippocampus volume, thus adding to the still mixed literature (Borba et al., 2016). Collectively, the results suggest that any

direct val66met/*BDNF* influence on overall hippocampal structure is likely to be subtle at best and to depend on other biological (genetic) and environmental factors not measured here. It is also possible that the *BDNF* val66met polymorphism might influence the structure of subfields within the hippocampus, rather than overall hippocampal volume. This could be addressed by studies conducted at a higher field strength, using protocols that distinguish between different hippocampal sub-regions (Voets, Hodgetts, Sen, Adcock, & Emir, 2017).

Similarly, I failed to find an overall genotype effect on volumes of the amygdala. One previous study found that Met allele carriers had reduced volumes of both the hippocampus and amygdala (Montag et al., 2009), but as with the hippocampus, the literature is mixed. One study found that Val66Met carriers who were exposed to early life stress showed reduced amygdala volume and increased depression (Gatt et al., 2009), and so it is possible that any effect of genotype on amygdala volume is dependent on gene-environment interactions. As with the hippocampus, it may also be the case that only certain amygdala nuclei are linked to *BDNF* genotype and so future studies would likewise benefit from using 7T MRI.

In contrast to hippocampal and amygdala volumes, analysis of cortical thickness did however demonstrate a significant effect of *BDNF* val66met genotype on parahippocampal (PHC) cortical thickness. My findings contrast with some previous studies however, which have shown reduced, (rather than increased) PHC thickness in met allele carriers (Yang et al., 2012) or no cortical thickness differences in PHC (Goldman et al., 2009). One study found an age x genotype interaction, such that with increasing age, Val allele carriers showed reduced cortical thickness in medial temporal lobe regions, including portions of the PHC (Voineskos et al., 2011) – although I found no such interaction in my data, with a more limited age range.

The interpretation of increased cortical thickness is complicated. Typically, in older adults, reduced cortical thickness has been related to poorer function, including neurodegeneration and impaired episodic and spatial memory (Blanc et al., 2015; Lehmann et al., 2010), whereas increased thickness is linked to better function. One possibility therefore is that increased PHC cortical thickness in 'at risk' Met carriers results from either better function in adulthood or from compensation (Reuter-Lorenz and Park, 2014). For example, in addition to a role in memory, the PHC plays a role in

emotional regulation (Delvecchio et al., 2012). However, longitudinal imaging studies reveal that cortical thickness values in individuals peak in adolescence, and then decline, a finding thought to reflect a process of cortical pruning (Ducharme et al., 2016), and several studies reveal a relation between better functioning and thinner cortex. For example, increased PHC thickness and volume is linked to ruminative tendencies (Du et al., 2015). Therefore, increased PHC thickness in Met alleles may reflect alterations in neurodevelopmental mechanisms linked to cortical pruning and optimization of functioning.

Of note, only males showed a significant effect of Met genotype on (increased) parahippocampal thickness. Whilst this finding highlights the importance of considering gender, it is inconsistent with previous findings suggesting that female met allele carriers are at increased risk of late life cognitive decline (Li et al., 2017). My results could suggest males, relative to female met carriers, either benefit from their genotype, or could face greater impact over their lifetime. It could also be the case that the effect of genotype on brain structure is more dependent on other genetic or environmental moderators than is the case with males. More longitudinal research is needed on this potential gender-related effect.

Genotype influences on structural covariation

An exciting and novel finding here is that *BDNF* val66met genotype influenced the structural covariance between the hippocampus and amygdala, two regions that show strong ipsilateral anatomical connectivity (Pikkarainen et al., 1999). Moderated regression analyses examining the effect of genotype on structural covariance found that carriers of the Met allele showed greater structural covariance between volumes of the left hippocampus and left amygdala relative to val allele carriers, when controlling for age, gender and total intracranial volume.

The mechanisms that underlie structural covariance have yet to be well characterized. One source of structural covariance is coordinated gene expression during neurodevelopment (Alexander-Bloch et al., 2013), in which *BDNF* signalling plays a key role. This may suggest a subtle underlying difference in healthy individuals that could subsequently impact on neural resources over the lifespan (Reuter-Lorenz and Park, 2014). As suggested in the PMAT framework, hippocampal-amygdala connectivity is

critical to emotional memory formation and regulation, and the impact of stress on memory (Ritchey et al., 2015). If altered structural covariation in Met allele carriers is present early in development, the associated functions such as affective learning and memory may be altered over an individual's life span, making those predisposed to experience enhanced psychological stress, and ultimately placing them at increased risk of developing stress related trauma (Hayes et al., 2017)

More intriguingly, structural covariance may also be influenced by functional network-mediated plasticity in response to stress itself. In animal models, exposure to chronic stress increases synchronized activity and functional connectivity between the hippocampus and amygdala (Chatterji et al., 2015) and impairs spatial memory, while enhancing fear learning (Izquierdo et al., 2016). In addition, lesions of the amygdala abolish the disruptive effects of chronic stress on hippocampally-mediated spatial memory (Chatterji et al. 2015). Intriguingly, such amygdala-dependent stress effects on hippocampal function mimic those seen in aged rats (Chatterji et al., 2015). In humans, negative early experiences (Fan et al., 2015), and even acute stress (Hermans et al., 2016), have been shown to increase resting state functional connectivity between amygdala and hippocampus. It has been suggested (Chatterji et al., 2015) that in response to prolonged stress, the amygdala influence on hippocampal function becomes dominant over other sources of hippocampal input as a result of prolonged structural remodelling of amygdala-hippocampal connections. Notably, BDNF signalling is thought to play a key role in such stress induced neurological remodelling including structural plasticity (McEwen, Nasca, & Gray, 2016). Thus, enhanced structural covariation in met allele carriers may reflect increased stress exposure or poor stress regulation (i.e. a result of gene-environment interaction effects). In either case, this finding may be important for understanding the link between *BDNF* genotype as a shared risk factor for stress disorders and late life cognitive decline, as well as the strong association between lifespan stress and development of Alzheimer disease in later life (Katz et al., 2016). It speaks to the utility of a life-course approach to cognitive aging (Reuter-Lorenz and Park, 2014).

It is unclear why such enhanced structural connectivity should be limited to left hemisphere regions, although one study found that patients with left (but not right)

hippocampal and amygdala damage present with difficulties encoding emotional material to episodic memory (Fastenrath et al., 2014).

Limitations

While having some notable strengths, including sample size, this study also has some limitations that should be acknowledged. Firstly, as discussed, whilst this sample included a large range, the average age of participants was only mid-twenties. Age has been demonstrated as having an important role in *BDNF* val66met effects on the brain and cognitive health (Voineskos et al., 2011). Inclusion of an older participant group could develop insights into subtle differences found in the current work. Lifespan longitudinal work will also be important to understand potential life-course effects of genotype on brain structure. Future work in much larger samples would also benefit from consideration of multiple genes, particularly the e4 variant of the *APOE* gene, when considering lifetime changes in cognitive health.

No measures of environment effects were included (e.g. emotional trauma, stressful events) or current cognitive function. Future studies could include measures of spatial and emotional memory function to link with the animal work described above, as well as using life history interviews to determine exposure to stress.

I used a ROI approach, based on strong a priori predictions, which focused on just a small number of regions. While increasing statistical power, this approach is limited in looking at genotype on wider network connectivity such as that proposed in the PMAT framework. Novel approaches to network structure based on graph theory (Evans, 2013) could be applied in future work. Additionally, other neuroimaging methods could be used to assess connections between regions; diffusion MRI, for example, could potentially construct white matter pathways between areas (Lang, Tomé, Keck, Górriz-Sáez, & Puntonet, 2012). This would supplement structural covariance methods that imply only covariance but not biological connections. Structural covariance does however offer an interesting insight in to correlations between anatomically distributed regions and can reflect function beyond white matter (Alexander-Bloch et al., 2013). Finally, the cellular basis of the factors that underlie findings associated with structural MRI are unknown (Evans, 2013). Additional studies relating structural MRI to underlying structural and molecular variation in 66Met knock-in mice will facilitate

further understanding of the effect of this gene on brain structure throughout the lifespan.

Summary

This study utilised multiple approaches to test for brain architectural differences associated with *BDNF* Val66Met genotype in healthy adults. I found that cortical thickness of the PHC appears higher in Met versus Val carriers. Volume analyses found no significant difference in hippocampal or amygdala volumes between genotype, but did suggest structural covariance differences between the amygdala and hippocampus as a function of genotype. It appears such structural covariance measures could tap in to subtle architectural differences between genotypes, even in healthy and typically young participants.

This study adds to the literature on the *BDNF* Val66Met polymorphism, highlighting a novel mechanism by which this genetic variation may influence emotion processing, memory, and ultimately lifespan cognitive and neural reserve. This is especially interesting given that the *BDNF* Val66Met polymorphism is a shared risk factor for stress related disorders, mTBI-PTSD comorbidity, and dementia. I have highlighted the need for further longitudinal work across the lifespan, use of detailed neuropsychological testing, and the analysis of structural networks. With such further development of research on Val66Met and neural architecture, a greater understanding of the neural reserve enriching and depleting factors on cognitive health over an individual's life-course might be gleaned.

The next chapter builds on this multi-factor life-course model, approaching the MTL from an environmental angle. It aims to assess how physical activity can influence the structures highlighted in this study, and their associated cognitive functions such as episodic and spatial memory.

3. Does Physical Activity Predict Hippocampal Volume and Everyday Memory in Healthy Young Adults?

Introduction

As detailed in the STAC-R model (Reuter-Lorenz and Park, 2014) (see general introduction), there are many routes to good and poor brain health and ultimately late life cognitive decline. Some are predetermined by genetics (see previous chapter), whereas others such as exercise and diet are, to varying extents, under control of the individual (Baumgart et al., 2015) (see Figure 3-1). Such modifiable risk factors are key targets for public health interventions. It is now well established that engaging in lifelong physical activity (PA) can delay or eliminate the onset of many chronic non-communicable diseases, such as type 2 diabetes, cancer and cardiovascular disease (Warburton, Nicol, & Bredin, 2006). For a long time, physical activity was considered to only have an indirect influence on brain and cognitive health by reducing the risk for these chronic health conditions (Warburton et al., 2006). However, accumulating evidence from animal and human studies suggests physical activity has a direct role in “neural enhancement” (Reuter-Lorenz and Park, 2014), by influencing both brain structure and cognitive function across the lifespan (for reviews see Voss et al., 2013; Prakash et al., 2015; Macpherson et al., 2017), as will be reviewed below.

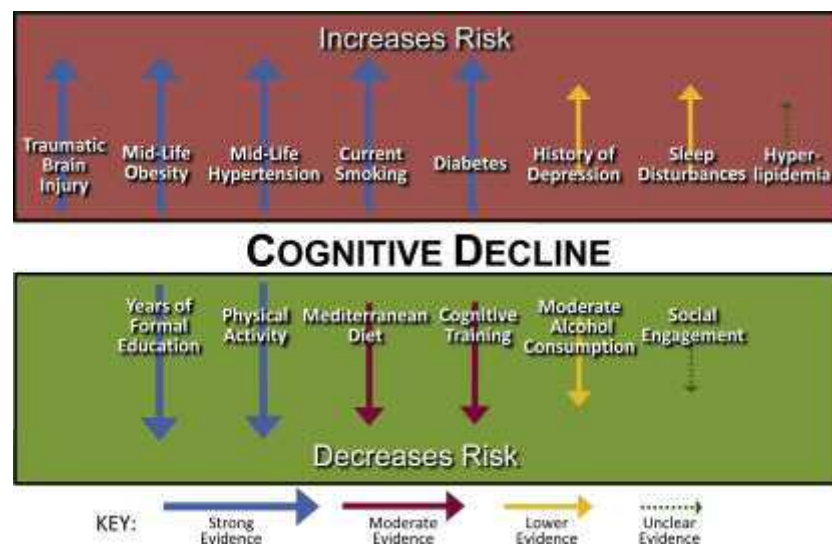

Figure 3-1. Strength of evidence on risk factors for cognitive decline from Baumgart et al. (2015) p.720

What is physical activity?

Physical activity (PA) has been defined as any bodily movement based activity that raises energy expenditure, whether through increased heart rate or muscle activity, above an individual's resting baseline (Thomas et al., 2012). Physical activity thus encompasses both exercise and non-exercise activity thermogenesis (Voss et al., 2013). A person's overall fitness level is related to several forms of physical activity or exercise that they engage in. Current health guidelines (published by UK Chief Medical Officers, 2011) recommend adults participate in moderate-intensity exercise for around 150 minutes per week – for example walking or swimming (Thomas et al., 2012). Such exercises utilise energy supplied by the aerobic system in comparison to more anaerobic vigorous-intensity forms of exercise including sprinting and weight-lifting. Guidelines propose a lower 60 minutes per week of these activities, in addition to 2-3 days per week of low-intensity balance and flexibility work (Thomas et al., 2012). Unfortunately, as a society, we do not do a very good job of getting the minimum recommended physical activity. According to The Active Lives Survey (ALS) published by Sport England (NHS Digital, 2017), in 2015/16, 26 per cent of adults were classified as inactive (i.e. taking fewer than 30 minutes physical activity a week). Notably, there is a difference in inactivity levels between men and women, with females (27%) more likely to be inactive than males (24%). There is a growing interest in understanding psychological barriers and enablers of physical activity and sport participation, including knowledge and attitudes, some of which will be considered in subsequent chapters.

Physical inactivity and risk for age-related cognitive decline

Mounting epidemiological evidence links physical inactivity across adulthood to increased risk of late life cognitive decline including Alzheimer's disease (Baumgart et al., 2015; Stephen, Hongisto, Solomon, & Lönnroos, 2017) (See Figure 3-1).

Furthermore, one large-scale longitudinal study found that levels of physical activity in early adulthood and midlife predicts late life cognition (especially memory and executive function) even when controlling for confounding factors such as long term illness, smoking, alcohol consumption, depression, and body mass index (Dregan & Gulliford, 2013). The mechanisms by which physical activity promotes cognitive and neural health and reduces the risk of late life cognitive impairment remain poorly

understood. Our ability to capitalize on physical activity as an intervention for improved brain health critically depends on a better understanding of the neurobiological mechanisms by which physical activity potentially promotes life-long neuronal enrichment as well as attenuating age-related neurodegeneration (Reuter-Lorenz and Park, 2014).

Physical activity and neuroplasticity in animal models

Within the animal literature, physical activity (e.g. voluntary wheel running) appears strikingly effective at facilitating some aspects of neuroplasticity, particularly within the hippocampus and surrounding medial temporal lobe – brain regions which, as I have previously discussed, seem to show the greatest lifetime degree of neuroplasticity (Walhovd et al., 2016). Voluntary wheel running promotes hippocampal neurogenesis, increases in dendritic complexity, and facilitates spatial memory. These effects depend on exercise-induced up-regulation of hippocampal BDNF (Voss et al., 2013). Vascular effects may also contribute, although a recent study combining structural MRI and histology, found that exercise increased hippocampal volumes were related to neurogenesis, rather than vascularisation (Biedermann et al., 2016). Importantly, some of the effects of physical activity are maintained throughout life in rodents (Voss et al., 2013).

Notably, brain areas highlighted in neuroplasticity research overlap with those considered vulnerable to ageing and dementia (Walhovd et al., 2014), in particular the hippocampus and surrounding MTL (Goh & Park, 2009). The generalisability of findings from animal models to humans is however unclear, especially as they are housed in typically impoverished environments, and other forms of environmental stimulation (e.g. social housing) also influence hippocampal neuroplasticity (Voss et al., 2013). Nevertheless, such findings provide a background for the investigation of similar effects of physical activity in humans.

The influence of physical activity on brain structure and cognition in humans

Both cross-sectional and longitudinal studies in humans support the observation that physical activity (in particular exercise) is beneficial for cognition (especially memory and executive function) and hippocampal and surrounding MTL volumes. Studies have linked high, moderate, and low intensity forms with cognitive benefits and neural

changes (Macpherson, Teo, Schneider, & Smith, 2017; Prakash, Voss, Erickson, & Kramer, 2015). For example, a learning assessment measuring memorisation of novel vocabulary found a 20% increase in performance in participants who had just previously completed a high-intensity sprinting exercise (Winter et al., 2007). Of note, similar to upregulation of central BDNF expression in animal models, this study also demonstrated that increased circulating levels of BDNF during learning following this exercise were linked to improved short-term memory. On the neural side, a longer term study found participants who engaged in moderate-intensity walking for 12 months demonstrated increased functional connectivity between brain areas involved in the default mode network and frontal executive network (Voss et al., 2010). These cognitive and neural effects of physical exercise have been suggested to reflect the impact of neuroplasticity and neurogenesis as seen in animal models (Thomas et al., 2012).

Neuroplasticity is a key component in an individual's ongoing cognitive development, describing the biological process behind adaptation to cognitive decline and learning of new skills, despite or in relation to genetic predisposition (Goh & Park, 2009; Walhovd et al., 2016). Whilst adult brains appear to show less plasticity than in childhood (Erickson, Gildengers, & Butters, 2013), there is still the potential for neuro-structural adaptation and plasticity – even in old age.

Higher levels of fitness in older adults has been linked to larger hippocampus and prefrontal cortex volume, more efficient neural connectivity, improved executive functioning, and memory (Erickson et al., 2015). Studies in this field have also benefited from a broad participant age range, suitable for assessing life-span effects.

A study in 44 children between the ages of 7 and 9, for example, utilised a fitness battery to assess cardiorespiratory fitness, muscular strength, speed, and agility in conjunction with neuroimaging analysis of subcortical brain structure and shape (Ortega et al., 2017). The authors found not only a significant link between fitness level and volumes of brain structures such as the hippocampus and amygdala, but specific effects of different measures. Hippocampus and amygdala expansion was linked to cardiorespiratory fitness typically tied to moderate-intensity exercise, whilst hand-grip was associated with alterations in several brain structures including the bilateral hippocampus and left amygdala.

Work with young and early middle-aged adults (18-45 years old) found self-reported minutes of exercise per week were correlated with grey matter volume in the right hippocampus (Killgore et al., 2013). However, this study did not make clear to participants what was considered exercise, and activities with all levels of intensity were included. The literature suggests the benefits or neural changes of different intensities of physical activity vary, or could differ depending on duration (Thomas et al., 2012). A meta-analysis of 14 controlled aerobic (moderate) exercise studies, for example, only found a significant effect on left, not right or total, hippocampal volume (Firth et al., 2018). As with the previously described work with children, different patterns of changes relating to physical activity may be influenced by the form of physical activity as well as other mediating or moderating factors in the larger life-span model.

A longer-term study of 299 adults with a mean age of 78 years measured physical activity based on the number of blocks walked per week (K Erickson et al., 2010). Participants were called back for neuroimaging nine years later and results revealed that past greater activity was linked to higher volumes in the frontal, occipital, entorhinal, and hippocampal regions. This held when controlling for gender, age, and factors that may be more relevant in this older sample group (such as vascular disease and hypertension). Notably the results suggested a plateau effect beyond a self-reported walking of 72 blocks per week and tied higher grey matter volume in three regions in particular to decreased risk of cognitive impairment, including the hippocampus. It appears that a large amount of physical activity is necessary for these longer-term effects however as, when divided in to quartiles, grey matter volume difference was only detectable in the highest activity group. As no measure of physical activity since then or at the time of scanning was completed, it is not possible to tell whether this indicates a limited life-span effect of physical activity on brain structure and cognition.

Interventional work has supported these findings however, providing greater insight in to the acute physical activity and cognition link. A randomised controlled trial with older adults involved participation in an aerobic exercise program consisting of walking

for 40 minutes per week (gradually increased from 10 minutes over the first seven weeks), with low-intensity stretching exercises before and after walking (Erickson et al., 2011). Control participants only completed the stretching exercise. Six and twelve-month follow-ups with imaging and memory assessment were carried out. An increase in hippocampal volume was found only in the aerobic exercise group, which also correlated with increased spatial memory performance. However improved memory task performance was found in both groups, supporting potential benefits for both forms of exercise, and suggesting cognitive changes that were not picked up in neuroimaging.

Research has also been completed in clinical populations, with previous literature suggesting physical activity interventions could serve to improve overall cognitive health. Male participants with schizophrenia who took part in aerobic exercise (cycling) three times per week, presented with increased hippocampal volume compared to controls playing table football (Pajonk et al., 2010). Improvement in a short-term memory assessment was correlated with change in hippocampal volume in both exercising and non-exercising patient groups. It is thus possible participants were still gaining some cognitive benefit from the non-aerobic exercise activity.

Interestingly, given the sensitivity of the hippocampus to chronic stress (see previous chapter) it has been suggested that some of the effects of physical activity on hippocampal volume, might relate in part to buffering against the effects of stress (Thomas et al., 2012). Elevated cortisol levels, linked to stress, are a mechanism for the development of diabetes (type 2) are related to hippocampal degeneration (Fotuhi et al., 2012). In one recent study, young adults who participated in a long-term aerobic exercise regime demonstrated enhanced episodic memory. Conversely, subjects that scored high on a depression inventory performed poorly (Déry et al., 2013). Animal work has also found that physical activity could protect young rats from negative effects of chronic stress exposure in later life through interaction with the hippocampus and amygdala, including protection from oxidative brain damage and memory impairment (dos Santos et al., 2017). Such findings can link back to the larger life-span model in which genetic factors also linked to both neuroplasticity and stress (*BDNF*) could interact with environmental trauma, brain structure, and cognitive health (see previous chapter). For example, Mata, Thompson, and Gotlib (2010) examined

whether *BDNF* genotype interacted with self-reported physical activity to predict depressive symptoms in 82 healthy adolescent girls. Higher levels of physical activity were associated with fewer depressive symptoms for girls with a met allele, but not for girls with the val/val genotype.

The current studies

Of the studies that have investigated the relationship between physical activity and brain morphology, the vast majority concentrated either on children (whilst the brain is still developing), or on adults aged 60 years and older (who may have hippocampal neurodegeneration) (Firth et al., 2018; Macpherson et al., 2017). Only a limited number of studies have investigated the relationship between physical activity and brain volumes at younger ages (e.g. Killgore et al., 2013, see above for limitations of that study). Thus, more evidence regarding the association between physical activity and hippocampal volumes in younger age groups is needed to draw conclusions as to whether physical activity during early adulthood is linked to neural enrichment, rather than just attenuating age-related neurodegeneration. In addition, previous research focused mainly on a single domain such as leisure time physical activity (McPherson et al., 2017). However, leisure time physical activity constitutes only one part of total daily activity. Physical activity typically occurs in various domains (i.e., recreational, household, transport, occupational). To address these limitations, in Study 1, I examine the relationship between hippocampal/MTL structure measured using MRI and physical activity measured across a wide range of daily activities in a young adult (student age) sample.

In addition, previous research has focused on examining the relation between physical activity and laboratory-based measures of episodic and spatial memory. The overall effects of physical activity on performance on these tasks have been somewhat weak (reviewed in Voss et al., 2013), possibly because laboratory-based tasks are less sensitive to individual differences in the range of normal functioning. To address this, I used a recently developed measure (the “survey of autobiographical memory”, SAM) (Palombo et al., 2013), which was specifically designed for the investigation of individual differences in naturalistic memory (see Methods section for details). The SAM comprises items assessing self-reported episodic, autobiographical, semantic, and spatial memory, as well as episodic future thinking. The study of naturalistic

autobiographical memory in particular has been suggested as a better predictor of day-to-day functioning than the less natural use of laboratory memorisation tests (Sheldon et al., 2016). In addition, as shown in functional MRI studies, autobiographical memory tasks tap into the functioning of MTL networks – including hippocampal, amygdala and parahippocampal cortical regions – to a greater degree than standard laboratory assessments of learning and memory (Chen, 2015; Sheldon et al., 2016), suggesting they may be better tests of hippocampal network integrity. In Study 2, I examine the relationship between physical activity and memory function in everyday life, assessed using the SAM. In both studies, I also consider the role of participant intelligence, as some previous work has suggested that increased intelligence is linked to increased participation in health related behaviours, including exercise (Deary, 2008). As part of a larger ongoing investigation, the participants were screened to ensure they represent a healthy sample and, as they were recruited through a single course university group, were likely to be highly homogenous. Findings may represent subtle variation in young healthy individuals that may be due to their different levels of physical activity and could represent the start of longer-term changes.

Study 1

Methods

Participants

Twenty healthy undergraduate student participants (female) between the ages of 20–22, were recruited through Cardiff University as part of a larger ongoing investigation. The study was approved by Cardiff University School of Psychology Research Ethics Committee, and all participants gave written informed consent. All participants completed a brief neuropsychological testing session and underwent structural neuroimaging.

Materials and Procedure

Demographics

Participant age and any history of mild traumatic brain injury was recorded. Specifically, participants were asked if they had ever experienced a knock to the head and if so how many times.

Neuropsychological Assessment

Fluid intelligence: Raven's Advanced Progressive Matrices

A short version of the Ravens Advanced Progressive Matrices (RAPM), comprising 12 items was administered. The RAPM is a well-validated assessment designed to test fluid intelligence utilising multiple choice answers to visual geometric patterns (Arthur & Day, 1994). The short-form measure has been validated through confirmatory factor analysis (Chiesi, Ciancaleoni, Galli, & Primi, 2012). Fluid intelligence has previously been linked to the update of physical activity, and so is important to control for (McPherson et al., 2017).

Physical Activity Levels

Global Physical Activity Questionnaire (GPAQ): Originally developed by the World Health Organisation (WHO), the GPAQ surveys self-reported sedentary behaviour and physical activity measures in three domains; Activity at Work, Travel to and From Places, and Recreational Activities.

Participants are asked to report if and how many days a week they engage in vigorous and moderate intensity activities for each domain (with examples provided), followed by how many minutes on average each time. Lastly participants are asked how much time they usually spend sitting or reclining on a typical day (ignoring time asleep). (See Appendix B)

Data were cleaned, with the requirement that participants answer in at least one domain but were removed if an invalid (e.g. >24 hours per day) answer is provided within any of the domains. Several methods for calculating outcome variables for the GPAQ are recommended by WHO, but this study utilised average daily sedentary activity, average daily physical activity in total (including transport), moderate-intensity, and vigorous-intensity.

The GPAQ has been tested in large scale population based work with the general adult population

(http://www.who.int/ncds/surveillance/steps/resources/GPAQ_Analysis_Guide.pdf)

and has shown moderate to high validity, grading differences in physical fitness, body composition, and activity as measured via accelerometer and pedometer, with long-term test-retest reliability of 0.53-0.83 for overall scores (Herrmann, Heumann, Der Ananian, & Ainsworth, 2013).

It should be noted that the GPAQ was originally developed for face-to-face interviews rather than as a self-report instrument. However, a written, rather than face-to-face interview format in the current study was adopted so as to reduce the potential effects of demand characteristics.

Structural MRI

Acquisition: Neuroimaging was carried out in the same scanner as described in Chapter 2, with scan acquisition taking approximately 7 minutes. High resolution T1 weighted structural scans were acquired on a Siemens 3-Tesla 3D HD XGE scanner at CUBRIC using an 8-channel receiver only head coil, with a T1-weighted 3D FSPGR sequence. The scan comprised 168 axial slices (TR/TE/TI = 7.8/3.0/450ms, flip angle = 20 °, FOV = 256mm x192mm x172mm, 1mm isotropic resolution).

Imaging Analysis: Volumes of the hippocampus and amygdala and cortical thickness of the parahippocampus were calculated using the open access software FreeSurfer version 6.0 (www.surfer.nmr.mgh.harvard.edu) and an automated FreeSurfer V.6.0 pipeline for hippocampal segmentation.

FreeSurfer constructs models of boundaries between grey and white matter along the pial surface, allowing for the extraction of anatomical measures of volume and thickness (see details in Dale, Fischl, & Sereno, 1999; Fischl et al., 2002; Ségonne et al., 2004). The pre-processing pipeline for T1-weighted images included; skull stripping, B1 bias field correction, tissue type segmentation, reconstruction of cortical surface models, labelling of cortical surface regions and sub-cortical structures, non-linear registration of the cortical surface, and visual quality checks. Estimated whole brain

intracranial volume (ICV) was calculated to serve as a covariate for volume analyses but is not necessary for thickness analyses (Westman et al., 2013).

Analysis

Data was coded for all 20 participants. Physical activity was scored as total average physical activity per day. Ravens APM scores were calculated as percentage correct scores and mild traumatic brain injury experience was coded yes or no. One participant's GPAQ score was removed due to a reporting error. Analyses looked at left and right Hippocampus and amygdala volumes separately. ICV was included as a covariate in volume analyses but age and gender were not since all participants were female and between the ages of 20-22. History of mTBI was reported in only 1 participant and as such could not be used in the analyses. To examine any non-linear relationships between physical activity and brain structure, GPAQ total activity per day was additionally divided into Lower and Higher Activity groups based on a median split.

Results

Participants reported an average of 111.50 (SD=72.65) minutes of physical activity per day. Raven APM scores were on average 73.750% correct (SD=18.599) and did not correlate with GPAQ total activity ($r=-.156$, $p=.538$), or ICV ($r=.120$, $p=.613$).

GPAQ total activity per day was not associated with hippocampal volume ($r=-.135$, $p=.594$), (Left: $r=-.160$, $p=.527$, Right: $r=-.068$, $p=.789$), amygdala volume ($r=-.109$, $p=.667$) (Left: $r=-.015$, $p=.953$, Right: $r=.183$, $p=.467$), or bilateral parahippocampal thickness ($r=-.122$, $p=.620$). Raven score was also not correlated with hippocampal volume ($r=.083$, $p=.729$), (Left: $r=.070$, $p=.769$, Right: $r=.091$, $p=.702$), amygdala volume ($r=-.161$, $p=.498$) (Left: $r=.210$, $p=.373$, Right: $r=-.084$, $p=.725$), or bilateral parahippocampal thickness ($r=.060$, $p=.801$).

When split into Lower and Higher Activity groups, GPAQ total activity per day was not significantly related to total hippocampal volume $F(1,16)=.048$, $p=.830$, parahippocampal cortical thickness $F(1,17)=.226$, $p=.641$, or amygdala volume $F(1,17)=.320$, $p=.579$.

Study 2

Whilst Study 1 did not indicate a relationship between physical activity and brain architecture, Study 2 investigated the cognitive correlates of physical activity in a larger sample.

Methods

Participants

One hundred and twenty healthy undergraduate student participants (all female) between the ages of 20–22 were recruited through Cardiff University as part of a larger ongoing investigation. The study was approved by Cardiff University School of Psychology Research Ethics Committee, and all participants gave written informed consent.

Materials and Procedure

Participants completed the same battery of neuropsychological assessments as described in Study 1 including; Demographics, mTBI history, Ravens Advanced Progressive Matrices, and the GPAQ. In addition, the completed the survey of autobiographical memory (Palombo et al., 2013).

The survey of autobiographical memory (SAM) (see Appendix D)

The SAM is a recently developed self-report instrument designed to assess inter-individual differences in naturalistic episodic, autobiographical, semantic, and spatial memory, as well as future thinking tendencies. Participants rate the extent to which an item (statement) described their overall memory ability on a five-point Likert scale ranging from Strongly Disagree to Strongly Agree.

Episodic/Event's eight statements were in relation to specific events occurring within a day or less happening at least 3 weeks ago, for example;

“When I remember events, in general I can recall what I was wearing.”

“When I remember events, in general I can recall people, what they looked like, or what they were wearing.”

Six Semantic/Factual statements probed participant’s memory for facts;

“I can learn and repeat facts easily, even if I don’t remember where I learned them.”

“I have a hard time remembering information I have learned at school or work.”

Six Spatial memory statements were described to participants as their ability to orient themselves in new or old environments such as;

“In general, my ability to navigate is better than most of my family/friends.”

“If my route to work or school was blocked, I could easily find the next fastest way to get there.”

Finally, six Future Events statements related to the individual’s ability to imagine future events with specific time/place detail and personal involvement. For example;

“When I imagine an event in the future, the event generates vivid mental images that are specific in time and place.”

“When I imagine an event in the future, I can imagine how I may feel.”

Weighted sum scores (based on factor loadings, (see Palombo, Williams, Abdi, & Levine, 2013) were calculated for each of the four domains and totalled to produce overall scores for each sub domain and a total SAM score.

Importantly, the SAM has been validated in a number of ways. Episodic elements of the SAM have demonstrated associations with depression (linked to episodic memory impairment), and performance on laboratory tasks such as scene recollection and autobiographical recall (Palombo et al., 2013; Sheldon et al., 2016). In addition, importantly, recent work highlighted how standardised general memory tests were unable to distinguish between those with measured ‘highly superior’ or ‘severely deficient’ autobiographical memory and controls, whereas the episodic domain of the SAM was able to (Sheldon et al., 2016). Finally, a recent resting state fMRI study found that individual differences in SAM scores were related to individual differences in resting state hippocampal connectivity (Sheldon et al., 2016).

Analysis

Physical activity was scored through four measures: Activity per day (average activity in minutes across leisure, work, and transport per day), Vigorous activity per day (summed vigorous activity in minutes per day across leisure and work, averaged), Moderate activity per day (summed moderate activity in minutes per day across leisure and work, averaged), and Sedentary behaviour (average daily minutes sedentary not including sleeping). Ravens APM scores were again computed as percentage correct and mild traumatic brain injury experience was coded yes or no. SAM scores were calculated as both an overall total and for each of the four domains; episodic, semantic, spatial, and future. One participant's GPAQ score was removed due to an error in reporting. Age and gender were again not included as covariates as all participants were female and between the ages of 20-22. History of mTBI was recorded in only 17 participants and as such could not be used in the analyses. Again, as in study 1, to examine any nonlinear associations between physical activity and SAM scores, GPAQ total average daily minutes activity were divided in to Lower and Higher Activity groups via median split.

Results

On average, participants reported 116.83 (SD=94.31) minutes physical activity per day (see Figure 3-2 for spread), of which 41.44 minutes (SD= 50.22) were moderate-intensity, and 24.19 minutes (SD 35.89) were vigorous-intensity. Participants also reported on average 396.69 (SD=179.97) minutes sedentary behaviour on average per day. Participants' average Raven APM percentage correct was 73.04% (SD=17.14), similar to study 1 levels.

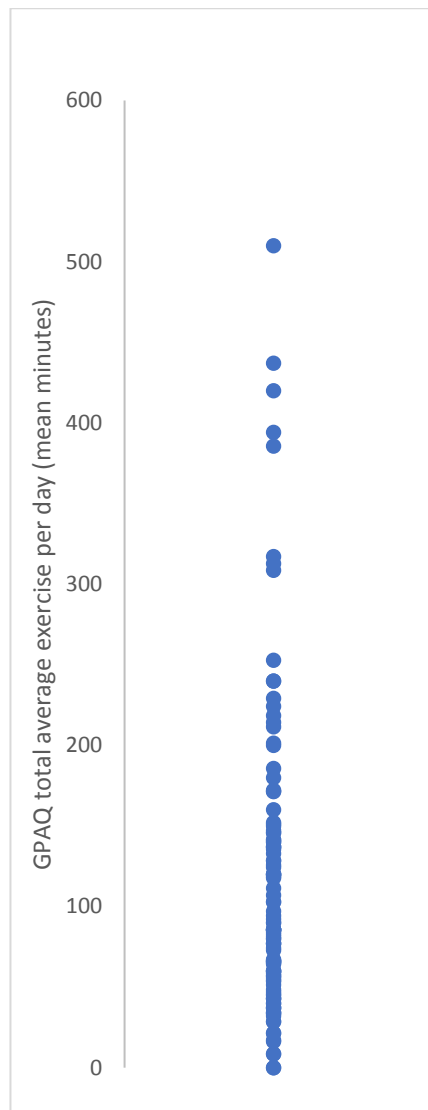

Figure 3-2. GPAQ total mean activity per day per participant.

Physical activity and survey of autobiographical memory scores

Pearson product-moment correlations between GPAQ total, moderate, and vigorous were calculated in relation to SAM total and the four domains (episodic, semantic, spatial, future) (see Table 3-3) Significant (negative) correlations were found between average daily physical activity (GPAQ total) and Semantic memory ($r=-.207$, $p=.012^{*1}$), and Vigorous physical activity with Semantic memory ($r=-.201$, $p=.014$) i.e. those reporting high levels of vigorous PA reported lower scores on the semantic memory component of the SAM. There were no significant relations between PA and any other SAM scores.

¹ Pass family-wise (0.05/4_ Bonferonni correction for multiple comparisons

	SAM total	SAM Episodic	SAM Semantic	SAM Spatial	SAM Future
GPAQ total	.041 p=.330 df:118	.010 p=.456 df:117	-.207 p=.012* df: 118	-.061 p=.257 df:117	-.146 p=.058 df:118
GPAQ moderate	-.022 p=.404 df:119	.055 p=.276 df:118	-.131 p=.078 df:119	-.041 p=.329 df:118	-.108 p=.121 df:119
GPAQ vigorous	.104 p=.129 df:119	-.055 p=.279 df:118	-.201 p=.014 df:119	-.128 p=.084 df:118	-.172 p=.031 df:119
GPAQ sedentary	.034 p=.359 df:116	-.030 p=.377 df:115	-.156 p=.047 df:116	.115 p=.111 df:115	.075 p=.213 df:116

Table 3-3. Correlation matrix for mean GPAQ minutes total and type, and SAM score total and in four domains.

Raven score was not correlated with SAM total ($r=-.069$, $p=.542$) or GPAQ total ($r=-.157$, $p=.165$). In addition, a moderated regression analysis (Hayes, 2013) revealed that Physical activity (GPAQ total) did not act as a moderator of Raven's score on SAM total score $R^2(3,76)=.0183$, $p=.702$.

Discussion

The above studies aimed to address the lack of research on links between physical activity and hippocampal volume and memory in young adults. Previous studies utilised lab-based measures of memory that show limited individual differences in normal range (reviewed in Voss et al., 2013), and did not look at a range of physical activities (e.g. transport). Study one did not replicate previous findings suggesting links between self-reported physical activity and hippocampal volume (Killgore et al., 2013).

Study two found limited associations between physical activity and autobiographical memory but suggested higher physical activity and vigorous activity in particular was actually linked to lower semantic memory scores. My findings thus do not support my hypothesis that physical activity in young adulthood is linked to better everyday memory.

Whilst previous animal work has demonstrated links between physical activity and MTL structure in relation to neuroplasticity (Voss et al., 2013; Walhovd et al., 2016), this study did not find a similar relationship in humans. As mentioned above, the generalisability between animal and human studies is unclear. Neither, however, did my study replicate human work that found a significant positive correlation between self-report exercise and hippocampal volume in young-early middle aged adults (Killgore et al., 2013), or that related participation in aerobic exercise programmes with hippocampal volume changes (Pajonk et al., 2010). Some variability may be explained by the young age of my participants in comparison to studies with older adults which have found higher fitness relating to larger hippocampus and prefrontal cortex volume (Erickson et al., 2015). However, the current sample size was also relatively modest (having the statistical power only to detect a large correlation ($r = 0.5$) with 80% power, 1 tailed) and any effects could be gender specific. For example, in Chapter 2 the reported *BDNF*-parahippocampal relationship appeared significant only in males.

The self-report measure for physical activity is susceptible to inaccuracies and bias but has been validated against other measures (Herrmann et al., 2013) and importantly includes physical activity outside of sport participation such as transport. Further work with a larger sample could provide greater precision, however a recent large-scale study of 834 participants between the ages of 25-83, and roughly equally mixed male and female, found no significant relationship between reported physical activity and volumes of the hippocampus, prefrontal cortex, and temporal lobe after appropriate statistical corrections (Jochem et al., 2017). It is possible therefore that my findings reflect a true null correlation between self-report activity and hippocampal volumes. As Jochem et al. (2017) studied individuals across a larger age-span, and included a multi-factor measure of physical activity (leisure time, work, sport), it could be suggested that future work should instead focus on physical activity interventions.

Longitudinal follow-up work could however allow for increased information on whether physical activity in younger groups could build capacity for later life changes not yet detectable in my current study (i.e. build brain reserve) or enable compensation against the impacts of aging and neurodegeneration in later life (Reuter-Lorenz and Park, 2014). With research focusing on the benefits of mid-life physical activity and neurodegeneration (Carlson et al., 2008), it could be that an individual who participates in exercise when younger is more likely to do so as they age, at which point fitness could preserve neural architecture and cognitive processing in the face of degradation. In addition, more fine-grained measures of individual differences in hippocampal structure, based on e.g. 7T MRI (Wisse et al., 2016) should be used as outcome measures. There is evidence from animal work that some hippocampal subfields (e.g. dentate gyrus) may be more sensitive to exercise effects than others). Measures of hippocampal function (e.g. task-based fMRI) and perfusion could also be utilised.

Study two aimed to assess 'naturalistic memory' links with physical activity, with previous work focusing on laboratory based episodic and spatial memory finding little consistent relationship with fitness (Voss et al., 2013). Autobiographical memory has been suggested as a more accurate predictor of day-to-day functioning (Sheldon et al., 2016) and relative to laboratory memory tasks, is more dependent on activity in MTL and amygdala regions (Chen et al., 2017). The current study found an unexpected correlation in which higher average levels of physical activity per day, specifically average vigorous activity levels per day, were associated with poorer semantic memory. I found no relation between activity levels and SAM episodic and spatial memory scores, despite previous work showing links between physical activity and spatial and episodic memory (Voss et al., 2013).

The reason for the negative correlation between semantic memory scores and physical activity is unclear. The SAM semantic domain includes statements regarding reading novels and information learning at school or work. As participants are all University students, the measure may be picking up on subtle differences within a relatively homogenous group; such as leisure time spent reading versus participating in physical activities such as sport. For example, high levels of sensation-seeking are linked to higher participation in active leisure activities, and lower participation in low-risk

leisure such as reading (Furnham, 1981). The finding could also potentially reflect self-stereotyping. However, if there is a true trade-off between physical activity and forms of 'intellectual' stimulation such as reading, this may be an important finding to consider in future intervention studies, as activities such as novel reading have been linked to reduced risk of Alzheimer's in women but not men (Crowe, Andel, Pedersen, Johansson, & Gatz, 2003).

A major limitation of the SAM, despite evidence of its convergent validity with performance and imaging measures, is that it is a self-report assessment, and is subject to several self-report biases e.g. memory self-efficacy (confidence) or demand characteristics (Beaudoin & Desrichard, 2011). The advantage of the SAM is that it was specifically designed as a measure of individual differences. Future correlational and interventional studies need to develop sensitive performance-based measures of memory that nevertheless are sensitive to individual differences within the normal range of functioning in order to test whether memory performance is related to brain structure and physical activity in young adulthood.

I did not find that physical activity was related to intelligence. Future work in larger samples should also assess the role played by other moderators – gender and age as already mentioned, but also e.g. BDNF genotype (see previous chapter).

The current study and recent larger scale cohort work thus suggests that previous findings linking self-report physical activity and neural structure, particularly of the MTL, could potentially be false positives. Previous positive results could be linked to other unmeasured potential correlates of participation in exercise such as increased water intake and social integration, for example. Links between higher physical activity and lower semantic scores potentially support the consideration of a multi-factor model of cognitive health, in which physical activity is not a simple 'magic bullet' to reduce degeneration risk, but is instead considered one contributory influence alongside others such as intellectual enrichment and socialisation. As such this work again highlights the role of multi-factor model of cognitive health. This is of particular interest when considering life-span cognition, as environmental factors (such as exercise and enrichment) could change over time and potentially interact differently with genetics and neural structure as we age. Importantly, it demonstrates the role of interventions, awareness of risk factors, and how engaging in one activity or behaviour

influencing cognitive health could result in the uptake or dropping of additional factors in a wider model. This will be addressed in Part 2 of the thesis, taking a health psychology approach to factors influencing cognitive health.

Part 2: Health Psychology

Introduction

Due to the integrated nature of this ESRC PhD scheme (see Chapter 1), Part 1 looked at both biological (genetics, neural structure) and social or environmental influences (physical activity) on cognitive health. Such an approach is more likely to build a detailed picture of the health processes across a life-span and provide guidance for interventions and policy. Concussion was also raised as a potential environmental risk but was not present in enough participants in Chapter 3 to allow investigation. However, it's links to neurodegeneration (McKee et al., 2013), and potential to interact with the other factors investigated in Part 1 is of note. Some physical activities are high risk for concussion (McKee et al., 2013), and *BDNF* has been linked to concussion occurrence (Dretsch et al., 2017), outcome (Larson-Dupuis et al., 2015), and has a complex relationship with physical activity as part of the recovery process (Mychasiuk, Hehar, Ma, Candy, & Esser, 2016). With this interaction with physical activity and genetics, increased recent concern regarding concussion and high levels of research and media coverage (Dewitt et al., 2013; Marshall, 2012), this is an important factor to address – a useful example of how complex health science is and an effective integration of biological and social research for health communication and impact. Part 2 of this thesis will shift focus to a health psychology perspective on themes addressed by Part 1's health neuroscience work. It will consider factors raised as potentially influencing cognitive health including; genetics, physical activity, and concussion. Such work builds on neuroscientific findings by allowing impact in the 'real-world' through policy and interventions. An understanding of a multi-factor model of cognitive health over a life-span is most relevant when applied to optimise people's cognitive development and minimise decline in later-life.

Chapter 4 will look at concussion, briefly introduced in Part 1 as an environmental risk that can sometimes accompany the more beneficial factors of physical activity through contact sports such as rugby and football. Concussion is a mild brain injury (Doolan et al., 2012) with repeated incidences linked to neurodegeneration, cognitive impairment and emotional decline (Doolan et al., 2012; Fotuhi et al., 2012; Perry et al., 2016). It

provides an interesting insight in to the multiple ways a risk-factor can influence health, and how awareness and knowledge can play a role in preventing and managing the risk at multiple stages and from different groups or individuals. This narrative review highlights how multiple factors influence attitudes, how concussion knowledge and attitudes are often poor, and how there is still a weak link between awareness and behaviours. It influences the following chapter's aim to model behavioural intentions through concussion knowledge and awareness, utilising some of the reviewed measures and discussed gaps in the literature.

Chapter 5 follows up this review of concussion awareness as an example risk factor with a survey and mixed-methods approach. This work aims to delve further in to the mental processes and influencing factors in parental decision making regarding activities that could have a beneficial or negative effect on their child's life-span cognitive health. It also allows for analysis of intended behaviours, typically not consistent with attitudes and knowledge. With interaction between environmental and genetic factors discussed in Part 1, parental decisions are also explored through the context of weighing up genetic risk with sport participation. An understanding of where information on cognitive health risks is sourced, and how these are mentalised for decision making, will aid in the design of more relevant and influential support for life-span optimal health.

4. A Narrative Review of Health Attitudes Research in Mild Traumatic Brain Injury

Introduction

Mild traumatic brain injury (mTBI) or concussion, an acute neurological condition caused by body or head impact (Doolan et al., 2012), affects almost 2 million people annually in the USA alone (Fakhran, Yaeger, & Alhilali, 2013). Acute symptomology (headaches, impaired memory, and concentration) can last between 7-10 days following injury (Doolan et al., 2012), with 15% of patients developing persistent problems (Fakhran et al., 2013) described as Post-concussional Syndrome (PCS) (Wood, 2007). Such injuries have received increased media, public, and scientific interest recently, due to high profile cases of Sports Related Concussion (SRC) in contact sports such as American football (Dewitt et al., 2013; C. M. Marshall, 2012) and in the UK, Association Football (soccer) (Brisbourne, 2017). There is now compelling evidence that even an acute mTBI can significantly increase risk of remote outcomes, including Alzheimer's disease (Doolan et al., 2012; Fotuhi et al., 2012; Perry et al., 2016). In addition, chronic TBI linked to repeated head of trauma of low magnitude in sports including football and boxing, leads to a neurodegenerative condition originally described as Punch Drunk syndrome in 1920's boxers – now re-termed Chronic Traumatic Encephalopathy (CTE) (McKee et al., 2013). CTE presents post-mortem with a unique pathology similar to Alzheimer's disease (Johnson, Stewart, & Smith, 2010). Symptoms are both cognitive and emotional, consisting of increased impulsivity, aggression, and depression, in addition to memory difficulties (McKee et al., 2013). Research attempting to identify predictors and causes of PCS and CTE have highlighted multiple factors, such as frequency of mTBI (Gardner, Shores, & Batchelor, 2010), genetic susceptibility (Blennow, Hardy, & Zetterberg, 2012), including *BDNF* VAL66MET genotype (J. Hayes et al., 2017) and organic neurostructural abnormalities (Miles et al., 2008), including hippocampal volume (Beauchamp et al., 2011), fornix white matter structure (Tate & Bigler, 2000) and medial temporal lobe cortical thickness (J. P. Hayes et al., 2017).

Mild TBI has thus been highlighted as a key potentially modifiable risk factor that can reduce or increase cognitive and neural 'reserve' throughout life (Fotuhi et al., 2012).

In line with an increased focus on modifiable risk factors and disease prevention, health psychology research, focused on attitudes and behaviours related to mTBI has been a growing focus.

Health Psychology Research in mTBI

Most empirical research on health-related behaviour from a social cognition perspective tends to emphasize attitudinal determinants. A broad array of 'attitude' definitions can be considered in different cognitive and emotional contexts (Eagly & Chaiken, 2007). However, a consensus could be its consideration as a 'psychological tendency', typically negative or positive in valence, in response to an evaluation of an attitude object (Eagly & Chaiken, 2007). It was originally considered through a tripartite model consisting the omnipresent influences of cognition, affect, and intentions (Eagly & Chaiken, 2007). Guided in part by the prominent 'health belief model' (Rosenstock, 1966), investigators typically assume that readiness to perform health-related behaviour is a function of such general attitudinal orientations as perceived vulnerability to illness.

Attitudes could be considered in mTBI research from several perspectives and would be especially important considering the current high media presence of chronic mTBI and CTE risk in sport. With concerned opinions and personal stories expressed on social media sites such as 'Twitter' (Sullivan et al., 2012) and being the subject of recent high-profile documentaries (Shearer, 2017), attitudes towards mTBI are likely emerging in the public. This may be particularly prominent for players of contact sports, parents, and coaches, following highly publicised court cases of long term impairment following SRC history in retired players (Monette, 2012). Whilst the focus was originally on American football, recent high profile UK cases of head injuries in rugby, and dementia in football (potentially linked to heading the ball) has led to increased pressure for research and appropriate safety guidelines (Brisbourne, 2017). Unfortunately, as highlighted by systematic review (McGlashan & Finch, 2010), social science theories such as attitudes psychology can often be forgotten in sports science research (only included in 11% of published work). This is a growing area of interest and would contribute greatly towards understanding of mTBI associated impairments in addition to aiding in the transfer of research to policy and practice for prevention and management of mTBI. With public interest in concussion, neurodegeneration, and

long-term risks of contact sports increasing, it is vital to gain an understanding of the area in order to aid prevention and create effective knowledge transfer beyond what is presented in the media. This narrative review aims to investigate the current literature on attitudes in mTBI research, with the aims of elucidating the topic areas in which it has been applied to date and, informing the development of a survey, and discussing potential future developments.

Methods

Databases Pubmed, Web of Science Core Collection, and Sport Discus were searched, with subsequent selection of relevant papers from reading of references. The searches were conducted with the terms 'concussion', SRC, 'mTBI', and 'mild TBI', in conjunction with 'attitude'. Only papers published in English and containing an attitude aspect with respect to a form of mTBI were included, however no restricted date frame was applied. The last update to searched and reviewed literature was conducted in May 2014 and a table of studies included can be found in the appendices (Appendix C).

Results and Discussion

Review of the selected literature revealed that studies to date were mostly limited to mTBI in the context of sport, despite the use of broader terminology beyond SRC in the search, that could in theory have included public and military injury (e.g. blast-injury related TBI). As such, arenas in which attitude psychology has been utilised in relation to mTBI fell in to distinctly sport related categories. Whilst there is some overlap between topics, the literature will be discussed in the context of attitudes' role in three areas: prevention; management; and symptomology of mTBI.

Prevention

Prevention of mTBI injuries could be enhanced through effective safety education or provision and enforcement of protective equipment such as headgear. These are both topics to which attitude psychology has been applied.

Sawyer et al. (2010) demonstrated how the role of attitudes must be considered in the production and dissemination of preventive education. In a pilot assessment of the federally developed toolkit for coaches, 'Heads Up: Concussion in

High School Sports', the authors considered the diffusion of innovation theory (Sawyer et al., 2010). This describes the uptake of an innovation such as safety education in five stages; from gaining knowledge to confirming it as useful. The formation of a positive attitude towards the adoption and use of the toolkit forms the second stage. The kit was described as 'very appealing' by 57% of coaches, and 'very useful' by approximately 70%. Since many coaches subsequently reported using the materials, the authors highlight the important role of their attitudes towards its appeal and usefulness in this resultant behaviour. Due to the nature of this pilot study, there was no longitudinal follow up. Thus, the long-term effect of coach attitudes on the use of preventive education cannot be ascertained. Another study on the 'Heads Up' toolkit broadened the assessment to include attitudes towards concussion itself following injury (Sarmiento, Mitchko, Klein, & Wong, 2010). Half of the youth coaches reported a change in attitude towards the seriousness of concussion. As such, attitudes towards the safety toolkit could link to a change in attitudes towards concussion risk and play a vital part in effective prevention. Both studies, however, did not assess the attitudes of players, parents, or school administrators; all of which may have an effect on its use. Sawyer et al., (2010) recorded 22% of coaches passing the toolkit on to other relevant school staff, but did not seek their attitudes towards concussion, or the materials and subsequent adoption. Sarmiento et al (2010) also described parents' attitudes towards concussion risk as a prominent barrier for coaches to implement preventive measures, despite their own potential attitude change.

In regards to safety equipment, surveys have been carried out across a range of sporting levels. Pettersen (2002), distributed questionnaires to both players and coaches consisting of both open and closed questions on attitudes, knowledge, and use of headgear. The study revealed low usage of headgear in rugby players despite 62% of participants agreeing it can prevent concussion. Cited reasons revolved around negative perceptions of headgear as an expensive and uncomfortable, but not mandatory, item. Attitudes towards the importance and effectiveness of headgear in mTBI prevention were even negative within coaches (Pettersen, 2002). A trial of Australian football players, looking at both headgear and mouth-gear usage (Braham, Finch, McIntosh, & McCrory, 2004) found similar results. Wearing headgear attitudes was assessed with Likert-style agree/disagree responses to questions such as "I would

rather risk injury than play with protective headgear/ mouthguards” (p.429 Braham et al., 2004) and “Experienced players do not need to wear protective headgear/mouthguards as they are not as risk of injury” (p.429). Ultimately, the authors discuss responses to these assessments in the context of beliefs. The authors report that many players did not believe headgear necessary, and few reported wearing any. This was in contrast to almost three quarters reporting use of mouthguards during play. A self-report survey based on attitudes towards protective equipment research in other sports was developed and distributed to rugby players under the age of 15 (Finch, McIntosh, & McCrory, 2001). Attitude assessment consisted of questions regarding reasons for wearing/not wearing headgear in the recent season, risk perception, and opinions on positives of headgear or what would encourage future use. 80% of players who wore headgear felt safer with it during play. Of the few players who didn’t wear headgear in the most recent season, common reasons were again due to discomfort such as increased heat. Thirty-nine percent of these players also selected “I don’t like to” (p.92 Finch et al., 2001) as a reason, whilst a more limited 7% expressed the belief that headgear didn’t work or was associated with being a ‘wimp’. In studies such as this it is apparent how individual attitudes towards headgear can be affected by the wider social context. Younger players might express personal attitudes more related to social attitudes or norms within their peer groups and could be influenced by parental attitudes towards headgear use.

This limited literature introduces attitude assessment in relation to prevention in mTBI within a sporting context, utilising both quantitative self-report closed scales and qualitative analysis of open-ended questions. Attitudes of coaches and players appear to play a role in the success of education for safety and prevention of mTBI, and in the use of equipment such as headgear, in line with the health belief model (Rosenstock, 1966). However, there are also suggestions of influence from other stakeholders such as parents and those in administrative and policy positions in prevention.

Management

Despite studies typically assessing multiple ways in which attitudes could influence mTBI management, typically attention in the literature has focused on either attitudes in relation to reporting incidents of concussion, or return to play guideline adherence.

Additionally, in contrast to preventive research, attitude research in mTBI management research has been strongly influenced by more recent social cognition theories that go beyond global measures of attitude to address more specific attitude-behaviour links (e.g. (Register-Mihalik, Linnan, Marshall, McLeod, et al., 2013).

Studies frequently reveal under-reporting or concealment of concussion in sports participants (Kerr et al., 2014; McCrea, Hammeke, Olsen, Leo, & Guskiewicz, 2004). An online survey of university athletes found that 43% of respondents knowingly hid concussion symptoms in order to continue playing (Torres et al., 2013) and that 69% of concussed young football players admitted playing while exhibiting symptoms of concussion (Rivara et al., 2014). In a review of 30 studies assessing reporting behaviour, reluctance to report SRC was frequently due to fear of being removed from play or letting down their team or coach (Kerr et al., 2014). Findings such as these emphasize the need for further attitude research in the area.

Register-Mihalik et al., (2013) investigated high school athlete's intention to report SRC, describing several contributing factors; direct attitude, subjective norms, and direct perceived behavioural control. This work expanded on previous studies on attitudes and reporting of SRC by examining more specific concepts that may play an influencing role. It was the first work to approach social cognitive predictors of mTBI reporting using the Theory of Reasoned Action and Planned Behaviour (TRA/TPB) (Ajzen, 1991). This theory has been applied in other areas of health research and aims to explain the link between attitudes and subsequent behaviours with increased reference to other social influences and pressures (see Figure 4-2) (Ajzen, 1991; Register-Mihalik et al., 2013)

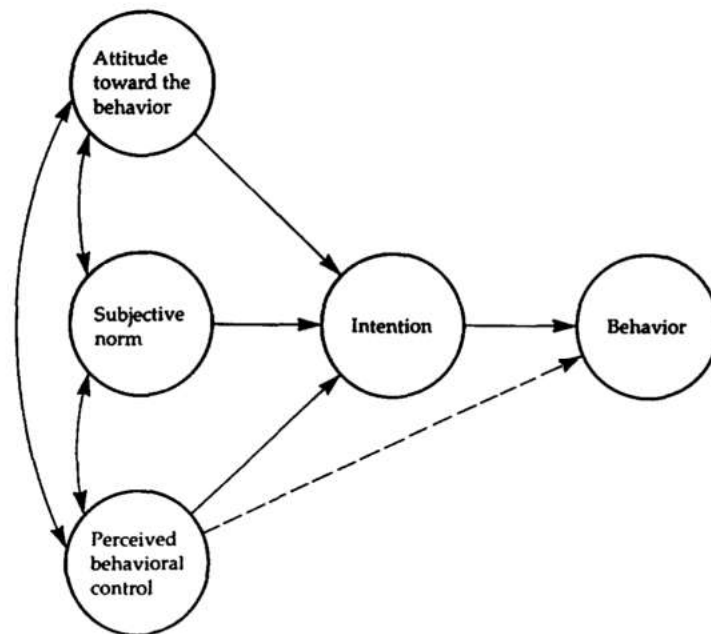

Figure 4-1. Theory of Planned Behaviour from Ajzen, 1991, p.182.

The original Theory of Reasoned Action was developed into the Theory of Planned Behaviour, as it was originally only designed to predict behaviours over which individuals had reasonable control (Godin, Conner, & Sheeran, 2005). The element of 'perceived behavioural control' was added, with its influence to be considered alongside that of subjective norms and behaviour related attitudes.

It focuses on an individual's attitude towards a particular behaviour, such as concussion reporting, rather than their overall (global) attitude to mTBI itself (Ajzen, 1991; Register-Mihalik et al., 2013). TPB would suggest that global awareness and attitude towards concussion will be poor predictors of specific behaviours that could aid in its management. One such study surveyed 133 young rugby players who, whilst expressing awareness of the seriousness of mTBI and long term effects, rarely said they would report concussion symptoms to their coach (Baker, Devitt, Green, & McCarthy, 2013). Register-Mihalik et al., (2013) used elicitation interviews to put together a questionnaire regarding players feelings about reporting concussion, should they suffer one. Direct questions asked for intention, plans, and effort to report, whilst indirect questions asked for level of agreement with statements such as "Reporting will help me maintain my health" (p.881, Register-Mihalik et al., 2013) and "Reporting will let my teammates down" (p.881, Register-Mihalik et al., 2013). Other TRA/TPB factors were also assessed. Social pressures in the form of subjective norms asked

players how much they cared about the thoughts of coaches, teammates, parents, and other students on reporting. Player's perception of behavioural control in such a scenario was measured with questions on how easy or difficult they found reporting if pressured by others. The study revealed that several factors resulted in increased likelihood of reporting symptoms: favourable attitude, coach and teammate influence, and perceived behavioural control. This work emphasizes the potential importance of understanding of attitudes in the management of mTBI, particularly within a broader social cognition framework such as TRA/TPB. It also benefits from assessment of both male and female athletes, reducing difficulties in applying the findings to practice. Unfortunately, the study used only young participants, so there may be differences when applying this theory to older or professional athletes.

Other studies have taken a similar approach to studying the role of attitudes in concussion-reporting behaviour. Through focus groups with both male and female young football players, thematic analysis (a method for identifying, analysing, and reporting patterns (themes) within qualitative interview data (Braun & Clarke, 2006)) revealed that social attitudes, reflected in factors such as coach approachability, were a common barrier to reporting SRC (Chrisman, Quitquit, & Rivara, 2013a). The same study found little effect of player SRC knowledge on reporting; which were believed to be over-ridden by the identified social attitudes in the team management. Kroshus, Baugh, Daneshvar, and Viswanath (2014) studied intention to report SRC using measures of attitudes, subjective norms, and perceived behavioural control (based on TPB). As a predictive model, it demonstrated a significant fit to the data, but was only accountable for a quarter of individual variance. A recent summary of 30 studies on factors associated with athletes' disclosure of SRC identified four levels of influence (Kerr et al., 2014). The devised socio-ecological framework of that paper included an *intra-personal level* (knowledge, internal pressure), *inter-personal level* (other's knowledge/attitudes, external pressure), *environmental level* (sports culture), and *policy level*. The lack of research on environmental and policy factors in conjunction with typical TPB factors such as attitude and social norms was suggested as a significant weakness in identifying significant predicting and influencing factors on SRC reporting behaviour (Kerr et al., 2014). It could be argued that TPB work does incorporate environmental factors, with reference to external social pressure and mTBI

awareness materials (Kerr et al., 2014; Register-Mihalik et al., 2013). However, Kerr et al. (2014) highlight the important role of wider environmental or cultural factors such as media influences, which may 'normalise' unconstructive attitudes towards mTBI symptomology and reporting behaviour.

The extant literature therefore suggests an important role for attitudes in mTBI management through influencing SRC reporting. Its impact appears to be in conjunction with other factors but to what extent is still inconclusive. A few studies have attempted to use this early understanding to test effects of reporting interventions, such as awareness and educational materials (Cook, Cusimano, Tator, & Chipman, 2003; Kroshus, Daneshvar, Baugh, Nowinski, & Cantu, 2014). Unfortunately, despite improvement in knowledge and overall awareness, there appeared to be little effect of these interventions on either SRC attitudes in coaches or in reporting behaviour. This may be due to the earlier described difficulty in effecting behaviour with a focus on attitudes towards the overall concept rather than specific actions (Register-Mihalik et al., 2013). This attitude-behaviour gap has been linked to intention formation, with individuals who's intended behaviour is based on moral norms more likely to predict behaviour than those based on attitudes alone (Godin et al., 2005).

Following the reporting of mTBI symptoms, a player may be removed from play for a period of time. This is to allow time for continued assessment and recovery before being returned to play or graduated stages of increased training (Doolan et al., 2012). Even though this is an important part of concussion management in sport, and there is an obvious role for social cognitive factors including attitudes, the literature on attitudes towards return to play (RTP) behaviour appears limited in comparison to that on SRC reporting behaviour. Sye, Sullivan, and McCrory (2006) surveyed school rugby players on their knowledge of concussion and RTP guidelines, their applicability to their playing, and if the guidelines were followed in practise. Whilst the objective of the study purported to include an assessment of attitudes towards the application of return to play guidelines, these were not in fact directly assessed. Instead, an attitude towards the seriousness of SRC and importance of safety guidelines was inferred from reported behaviour that only 22% of players sought medical clearance instead of making their own decision on when to return to play. The authors however, attributed

this towards ineffective distribution of information and poor knowledge in players. With a more direct assessment of attitudes, it could be easier to clarify the role they play in following RTP guidelines. Rosenbaum and Arnett, (2010) addressed return to play in their development of an assessment of knowledge and attitudes towards concussion. The aim was to improve on the currently available assessments as used in Sye et al., (2006), which provided no psychometric information on the quality of the survey (Rosenbaum & Arnett, 2010). They also referenced the Knowledge and Attitudes about Sports Concussion Questionnaire (KASCQ-24), devised as part of a doctoral thesis, as it mostly consisted of knowledge based questions (Rosenbaum & Arnett, 2010). The Rosenbaum Concussion Knowledge and Attitudes Survey- Student Version (RoCKAS-ST) contains 15 attitude questions, including RTP in a wider context of attitude topics (coaches and personal attitudes) (Rosenbaum & Arnett, 2010). With development of the limited number of attitude questions, this assessment could be further utilised in research to assess the currently overlooked aspect of RTP attitudes in addition to other management factors such as reporting behaviour. Exploratory factor analysis was also used in the development of the attitudes component of the questionnaire, providing a less general attitude measure and instead suggesting attitudes scores relating to particular aspects such as player perception of themselves, their coaches, and their team mates (Rosenbaum & Arnett, 2010). This once again highlights the importance of player attitude research in combination with other social factors.

In summary, the current literature on social cognitive factors, specifically attitudes, in the context of mTBI management has focussed on reporting behaviour and RTP guideline adherence. The literature appears to be moving towards a broader social cognitive perspective on attitude influence, incorporating theories such as TPB (Ajzen, 1991) in specifying behaviour related attitudes, and incorporating external factors like knowledge, sport culture, and media influence. Whilst the literature may not have been utilised successfully in psychological interventions to date, it presents as an important foundation in understanding the social cognitive factors involved in mBTI management. Successful transfer of these multi-factor attitude-behaviour models to practice, may also expand their use to the prevention literature.

Symptomology

In considering the role of social cognitive influences, specifically attitudes in the context of mTBI symptoms and recovery/plasticity, a natural debate between the organic biological causes of impairment and recovery following injury, and potential psychosocial influences or modifiers presents itself. Some of the reviewed literature reflected this debate, with several investigations of the role of attitudes in symptom expression following mTBI. This, less specifically sport-focused, aspect of the role of social cognitive factors like attitudes in mTBI is still in its infancy, and the literature appears more variable and explorative.

Wood (2004) considered PCS within a diathesis-stress paradigm which includes an individual's vulnerability (diathesis) to a disorder following an environmental trigger (stressor) such as mTBI. The model includes pathophysiology, cognitive, emotional, and motivational factors. Attitudes are highlighted in the motivational component. They are described to change, along with perception and expectations, based on differing attribution of injury cause. Development of a pessimistic attitude towards treatment outcome, when pain following injury was attributed towards fault in others, was given as an example (Wood, 2004). Mulhern and McMillan (2006) looked at knowledge and expectation of mTBI symptoms in the general population. Whilst the work did not directly aim to assess attitudes (instead focusing on poor public knowledge of mTBI), the investigators found that higher ratings of the 'undesirability' of mTBI were associated with an increase of reported PCS symptoms expected from a hypothetical vignette about mTBI. Notably, past experience of mTBI did not improve symptom knowledge. More recent work investigated the effects of mTBI severity, knowledge, and level of undesirability, in relation to post-concussive symptoms as part of an expectation-as-etiology hypothesis (Sullivan & Edmed, 2012). Knowledge of mTBI did not produce varying expected symptoms. Perceived undesirability however, was associated with reports of increased expectancy of PCS symptomology when participants were presented with vignettes describing more serious motor-vehicle accidents. If perceived undesirability of mTBI reflects an attitude (which seems a reasonable assumption), these studies could link prior attitudes with potential symptomology or symptom reporting following a mTBI. However, this cannot be

currently established due to reliance on hypothetical vignettes and will be difficult to establish empirically. The potential for effects and need for further study is supported by broader work linking an individual's expectancies, and neural activation, to experience of pain intensity (Atlas & Wager, 2012).

Other studies in which attitudes were alluded to (and listed as keywords) did not investigate the attitude-symptomology link directly and instead looked at the influence of knowledge (Mackenzie & McMillan, 2005), terminology (Weber & Edwards, 2010), depressive attitudes towards problems (Bohnen, Jolles, Twijnstra, Mellink, & Sulon, 1992), injury cause severity (Aubrey, Dobbs, & Rule, 1989), and recovery beliefs (Snell, Hay-Smith, Surgenor, & Siegert, 2013). A postal survey of A&E doctors, neurosurgeons, and clinical neuropsychologists collected opinions on PCS (Davies & McMillan, 2005). Unsurprisingly, biological factors were described most commonly as the cause of PCS, but this was followed by emotional factors. Such research has highlighted not only the attitudes of relevant professionals in mTBI medical care but suggests a perceived role of emotional factors such as attitudes in symptomology. Perception of occurrence of an mTBI was significantly altered in reporting participants dependent on the terminology used in a study by McKinlay, Bishop, and McLellan (2011). For example, perception of negative attributes, a potential attitude component, towards an injury was greater when described as a brain than a head injury. Whittaker, Kemp, and House (2007) described PCS as a medically unexplainable syndrome of which current literature cannot define a solid biological or psychological cause, but supported the potential role of social cognitive factors including illness perception in persistence of PCS.

The reviewed literature with regards to the attitude-symptom relationship arguably presents less clearly than the other areas of prevention and management.

Nevertheless, the need for future work in this area is reinforced, and some literature even reflected concern on how psychological rather than organic findings could impact diagnosis and treatment (McBeath, 2000). As positive attitude effects on prevention and management should aim to be long term, symptomology work will need to look at more longitudinal symptomology such as PCS's development in to CTE. However, the area currently benefits from use of wider causes of mTBI (e.g. motor-vehicle accidents

(Sullivan and Edmed, 2012b)) and non-athletic participant groups. This allows for a more general understanding of attitudes in mTBI and resultant symptomology.

Summary and Recommendations

In summary, the reviewed literature highlights three key areas for social cognitive attitude research in mTBI research within a sporting context; prevention, management, and symptomology. Methods for doing so have ranged from qualitative exploratory work (Chrisman et al., 2013a) to more quantitative surveys and reporting of behaviour (Braham et al., 2004). Attitudes towards educational material and headgear use highlighted the discrepancy between intentions, understanding, and subsequent reported preventative behaviour. This issue was tackled to some extent in research on the management of mTBI, with investigations of attitudes towards the management of SRC incorporating multiple factors from relevant social cognitive attitude theories including Azjen's (1991) Theory of Planned Behaviour. Less research on sport-related mTBI has investigated attitude-symptomology links, which is an important topic for future investigation.

Several limitations in the extant literature were highlighted, with reference to the design of future investigations. In order to create a more solid understanding of concussion in sport, social cognitive, including attitude, work must expand more broadly. Inclusion of attitudes in players, coaches, and parents, in addition to the wider public and media context would be beneficial considering the apparent role of social influence factors on health-related behaviours (Kerr et al., 2014). Study of public attitudes is especially important as, prevention, reporting, and adherence to medical advice following mTBI is relevant to non-sporting injury too. Increased applicability of attitude interventions, such as education and awareness programmes, could benefit from assessment of attitudes towards particular behaviours beforehand, and tailoring to individuals (based on factors including gender, age).

The current literature however, does show the potential role of social cognitive factors including attitudes in multiple aspects of mTBI (prevention, management and symptom reporting and recovery) and adds to a more detailed understanding on the injury and potential long-term remote consequences of mTBI. With further study, such findings will be highly relevant to practice and policy in both contact sports and public

health more generally. Methods of measuring attitudes to date have been highly diverse, and often not sufficiently focused. Instead, studies should investigate beliefs, perspectives, or opinions and judgement of risk. Future research may particularly benefit from researching attitudes related to mTBI with a focus on particular (specific) behaviour-related attitudes (e.g. wearing of safety equipment, reporting of injuries), social and cultural factors such as media influence and education provision, and individual difference factors including personality and cognitive traits such as risk attitudes. This would provide a greater understanding of the often-overlooked social cognitive components of mTBI prevention, management, and symptomology.

The following chapter will report mixed-methods results from a survey developed based on the above literature, and more recent findings focusing on parental attitudes towards concussion. As identified in the current chapter, attitude formation is related to multiple factors including social influences and knowledge. The following chapter will investigate which factors can predict attitude related concussion safety behaviour in parents, consider their decision-making process, and identify information sources and knowledge. Such work aims to utilise and develop measures identified in this review, hone in on the emphasised role of parental decisions in child sporting health, and build a greater understanding of the link between attitudes/knowledge and behavioural intent – a link described throughout as unreliable.

5. Factors Affecting Contact Sport Attitudes and Knowledge in Parents

General Introduction

Approaching cognitive and neural health from a life-span perspective emphasises the importance of early years and childhood development (Anstey, 2014; Jagust, 2016; Reuter-Lorenz & Park, 2014). In Wales, a focus on the early developmental years has been named the 'First 1000 Days', and aims to bring together multiple agencies, both charitable and public service, to focus on how parents, carers, and families can be supported in order to get the best health and wellbeing outcome for children (G. Murphy, 2017). Such initiatives include 'Flying Start' where, along with parenting programmes and childcare support, health visitors will support families in their homes assessing the child and family risk and referring if appropriate (Welsh-Government, 2017). Necessarily, despite this, much of the responsibility of health and well-being decision making for children falls on parents and guardians. Parents currently face something of a dilemma in relation to their children's sport participation, with long standing emphasis having been placed on the benefits of sports and exercise, whereas recent news reports and social media has increasingly highlighted the dangers of sports related concussion (SRC), culminating in a Hollywood movie 'Concussion' starring Will Smith (Carson, 2017).

As an acute condition, concussion can occur following a blow to the head or body, with symptoms usually resolving within 10 days (Doolan et al., 2012). It is a form of mild traumatic brain injury (mTBI), usually classified based on a lower-end Glasgow Coma Scale score of 13-15 (Niogi et al., 2008). Within this mTBI category, a concussion's severity can vary dependent on factors such as loss of consciousness, amnesia, and brain pathology (Williams, Levin, & Eisenberg, 1990) – but there are also suggestions of potentially long-term neurodegenerative effects (Carson, 2017; Doolan et al., 2012; McKee et al., 2013). This is particularly relevant in children and adolescents who are in general at increased risk of traumatic brain injury including concussion, particularly males between 10 and 19 years of age (Bloodgood et al., 2013). How parental knowledge, attitudes, and behaviours, are changing in response to this emphasis on the potential remote effects of concussion is important in understanding parental

decision-making processes and how they could in turn influence a child's life-long cognitive health.

Attitudes form a critical aspect of social cognition, being considered a 'psychological tendency' to evaluate an attitude object, typically positively or negatively, and with influence from the three aspects of a tripartite model; cognition, affect, and intentions (Eagly & Chaiken, 2007). As detailed in the previous chapter, attitudes have been shown to play a role in the prevention of concussions through their impact on use of safety equipment (Finch et al., 2001), and potentially in the effective management of such injuries through following guidance including return-to-play schemes (Sye et al., 2006). Such attitude related influences are frequently overlooked in sports medicine research (McGlashan & Finch, 2010), and yet could be of high importance in relation to influencing both the perceived health benefits and risks of sports participation. Social and cultural factors, including media coverage, can influence individual attitudes and behaviours, potentially normalising unconstructive attitudes toward mTBI (Kerr et al., 2014), and possibly lead to inappropriate responses to concussion risk management to the extent of withdrawing from sports entirely – losing the well-documented benefits of exercise and participation that sport participation brings (Carson, 2017).

Prior research and the previous review (see Chapter 4) has demonstrated that assessing the attitudes of individual sports participants (i.e. players) alone can miss the vital role played by broader influences on individual attitudes and behaviour (Sanderson, Weathers, Snedaker, & Gramlich, 2017). Parent impact on the management and prevention of concussions may be significant with the emphasis of social media based concerned opinions and personal stories (Ahmed, Sullivan, Schneiders, & McCrory, 2012), the production of documentaries (Shearer, 2017), and court cases presented via multiple news outlets (Monette, 2012). Negative attitudes towards mTBI and high contact sports are potentially developing in parents (Carson, 2017). A clash of attitudes towards concussion between parents and coaches (e.g. parents who believe that some degree of injury in children is an acceptable compromise for the physical benefits associated with physical activity and the development of abilities to appraise and deal with risks (Quarrie et al., 2017)) has been described as a barrier to the implementation of effective preventative measures by coaches, despite the latter receiving training on sport concussions and showing

potential attitude changes themselves (Sarmiento et al., 2010). A pilot study of parents of male high school rugby players in New Zealand found that only 51% were aware of return to play guidelines following a sport concussion (Sullivan et al., 2009) despite 96% being aware of the risks of continuing to play and 83% self-reporting the ability to recognise concussion in their child. Attitudes towards concussion risk and decision-making to allow their children to continue playing appear to have been made in the absence of sufficient information on the risk and its management. It is not possible to conclude from that study whether the parents who believed they could were genuinely able to recognise concussion. The authors of that study describe the parents as the next level of the concussion 'safety net' due to their familiarity with their child's behaviour, potentially leading to earlier identification of subtle cognitive or emotional changes. The authors suggested that prevention information should be targeted at parents, who's own increased awareness of concussion could lead to better management of the injury in children, something typically overlooked in favour of interventions with coaches and medical professionals (Sullivan et al., 2009).

An online survey of US parents of youth in sports (age 5-18), found an overall high level of awareness/knowledge in parents (85%) but also revealed potentially moderating factors such as race, age of children, and internet usage (Bloodgood et al., 2013). Poorer knowledge was found in parents of children between the ages of 5 and 9, with increased awareness linked to using the internet several times daily. Eighty-five percent of parents believed that concussion was a critical issue, compared to 53% of the youths themselves. That study also went further by investigating the source of concussion information within their parent sample. Fifty five percent of parents reported seeking information on concussion, with the majority (39%) using Internet search engines and health related websites. Parents also sought information from medical professionals, friends and family, social media and online forums. Services and organisations identified as reliable sources of information on concussion were mostly the Centre for Disease Control (CDC) and Prevention and a doctor or healthcare professional. Overall, mothers were significantly more likely than fathers to consider concussions an important issue (Bloodgood et al., 2013). It is clear that additional factors such as gender need to be considered in order to build a more complete attitude model and develop targeted interventions, especially as sources of

information and information seeking habits can vary greatly between parents. Recent work by Cusimano, Zhang, Topolovec-Vranic, Hutchison, and Jing (2017) surveyed members of athletic communities in Canada, measuring concussion knowledge and association of scores with various individual differences factors. Significant influence was found for age, income, education, first language, and experience of concussion, and it was suggested future initiatives design around these considerations.

More recent work on parental attitudes made use of this multi-factorial approach, asking childless non-athlete college students '*If you had a child, would you let him (or her?) play football?*' (Fedor & Gunstad, 2016), specifically American football.

Participants completed a demographic and medical survey including their history of concussions, in addition to a concussion knowledge assessment, risk perception questionnaire, and an 'excessive concussion' scale (e.g. how many concussions is too many for an athlete/child to receive per season/year?). A general health literacy assessment and medical term recognition test were also completed. Parental years of education, concussion history, knowledge, and health literacy did not influence whether they would allow their child to play football. Participants who expressed a riskier attitude (i.e. allowing their child to play) were, however, more likely to be female, slightly younger, and to believe that athletes could suffer a higher on average number of concussions before it becomes 'excessive'. However, despite highlighting potentially influential factors in the parental decision-making process, this study did not use actual parents or control for potentially similar relationships such as the presence of a younger sibling. This sample is unlikely to reflect the attitudes, knowledge, and behaviours of actual parents. The approach however, is in line with the Theory of Reasoned Action and Planned Behaviour (TRA/TPB) model of attitude development and behaviour transfer (Register-Mihalik, Linnan, Marshall, Valovich McLeod, et al., 2013) described in the previous chapter. To reiterate, according to TRA/TPB, behaviours are a product of three antecedents: attitudes (beliefs about the behaviour's likely consequences), subjective norms (the expectations of important others such as family, friends, the media), and perceived behavioural control (beliefs about the presence of factors that control behavioural performance). The TRA/TPB focuses less on global attitudes instead describing attitudes and intentions towards a particular behaviour, (in this case allowing a child to play football, rather than sport in

general) and including multiple influences on the decision-making process. The TRA/TPB framework should allow for more realistic measurement of attitudes and a better prediction of behaviours in this context. It is also able to incorporate elements such as peer pressure, which could come from multiple sources in both children's and parent's experience (e.g. coach, friends).

The current study aims to extend this multi-factorial and behaviour-specific approach to actual parents of children under the age of 18, where the parent has significant influence (but not sole influence, with demonstrated effects of peer effects (Kroshus et al., 2015)) and, importantly, typically legal responsibility. A study of both male and female athletes in a variety of contact sports, found more than one quarter had experienced pressure to continue playing after a head impact during the past year (Kroshus et al., 2015). Pressure from multiple sources (teammates, parents, and fans) to continue playing in the future was more influential on intention to report symptoms than none or less diverse pressure. Parents' attitudes towards concussion as a risk could act as an additional source in a larger collection of influential peer pressure on their child. In line with TRA/TPB, utilising detailed specific measures (see below), may reduce the typically weak power of attitudes as an indicator of actual safety related behaviour such as reporting injury and wearing protective equipment (i.e. the attitude-behaviour gap) (Kerr et al., 2014; Pettersen, 2002b; Sarmiento et al., 2010). Limited knowledge of concussion for example has been demonstrated in parents of players (Mannings, Kalynych, Joseph, Smotherman, & Kraemer, 2014), medical staff (Zemek et al., 2014), and the wider public (McKinlay et al., 2011). The importance of combining attitudes and knowledge in social cognition studies is raised by focus group work in football players, that suggested concussion knowledge was overridden by attitudes in team management (Chrisman, Quitiquit, & Rivara, 2013b). The ability for team management to override an individual's attitudes reflects the importance of social norms in attitude formation and the transfer to behaviour. When investigating athletes experience not reporting concussions, Sanderson et al. (2017) found participants frequently referencing wanting to conform to social norms, described through two sub-themes; adherence to the pain principle (in an effort to please the coach), and team allegiance (focusing on the collective needs of the team). The latter of which appears to represent how a potential benefits of sport participation (teamwork,

friendship) could also influence negative behaviour. A public survey that assessed both attitudes and knowledge found substantial knowledge inaccuracies in response to 10 concussion related statements (McKinlay et al., 2011). However, whilst familiarity with brain injury was measured through their medical history and that of friends/family, potentially influential factors such as education level were not considered.

Additionally, here, other injury-risk and health-benefit measures will be included as, whilst there is typically the assumption that parents are considering the other risks and benefits of sport as they complete attitude assessments, they are often not actually directly measured (Fedor & Gunstad, 2016). Parents were also asked to consider their decision in relation to multiple contact sports, rather than just one (given that actual concussion risks vary across sports (Quarrie et al., 2017)) and with the addition of a 'genetic risk' item. With a recent increase in direct-to-consumer genetic testing services (McCartney, 2015), together with recent research suggesting gene-environment interactions related to risk-taking behaviour (Salvatore et al., 2015), life-span cognitive health (Jagust, 2016), benefit from exercise (e.g. the earlier described influence of BDNF) (Erickson, Miller, & Roecklein, 2012), and poor outcome from concussion (J. P. Hayes et al., 2017), this topic is likely to reach the wider public and become a factor in decision making in the near future. Participants were also asked to describe their information sources for concussion and service awareness on three key themes; concussion, dementia, and genetic risk (i.e. interest in genetic testing, concerns regarding specific genetic risk-environment interactions, or concerns related to hereditary neurodegeneration risk following family experience).

A mixed methods approach was used, including the use of qualitative thematic analysis consistent with previous work (Chrisman et al., 2013b; Pettersen, 2002b). The advantage of this mixed methods approach is that it can identify potentially relevant contributing factors that may be missed in a wholly quantitative, directed analysis of closed questionnaires (Madill & Gough, 2008) and could ultimately be used to develop more effective prediction models of safety behaviour in future work, or more effective interventions and knowledge transfer. Recent UK work utilised the RoCKAS measure to measure attitudes and knowledge in twenty-six professional football players (J. Williams, Langdon, McMillan, & Buckley, 2016). The authors found overall moderate knowledge and safe attitudes towards concussion, but a poor link between these

scores and intended behaviours was presented through semi-structured interviews. This supports the use of quantitative measures such as the RoCKAS in combination with other, potentially qualitative, assessments of attitudes and knowledge (particularly those relating to behaviour). It is clear that multiple approaches to attitude assessment are necessary in order to understand how individuals may behave in reality with regards to concussion management.

General Methods

Questionnaire analysis followed the same below general methods, however was divided in to three parts representing different methodological approaches to the same general theme discussed in the introduction.

Participants

Three hundred and sixteen participants (71 male, 245 female) between the ages of 19-72 years ($M=37.47$, $SD= 9.16$ years) were recruited via the Prolific website (www.prolific.ac). This website provides an anonymous link between researchers and potential participants worldwide, allowing for screening and online payment. Participants were screened for currently having child/ren (biological or adopted/fostered) under the age of 18 and being first language English speakers (relevant to the medical literacy assessment). Participants were reimbursed via online payment after submission. Final sample size was achieved from a total of 332 submissions as a result of the removal of 16 individuals: 1 due to consent error; 4 unconfirmed completion ID; 10 completed under 300 seconds; and 1 follow-up message requesting removal of submitted data. The study was approved by Cardiff University School of Psychology Research Ethics Committee, all participants signed consent forms prior, and received a debrief including information on how to access further support/information regarding concussion, dementia, and genetic concerns. Participants had on average 14.58 years of full time education ($SD= 3.91$ Min=5 Max =25), and a medical literacy score of 29.23/34 ($SD=6.13$) (see below for Medical Literacy assessment details).

Materials and Procedure

Participants were directed to an online consent form and survey created using Qualtrics™ software (www.qualtrics.com). In addition to basic demographics (age, gender, education, occupation), the survey included the following sections and took between 10-30 minutes to complete. No questions were compulsory.

Concussion and Dementia Experience: concussion history, family history of dementia, child concussion history

Allowed Sports: A check-list of contact sports that the participant would allow their child/ren to play (rugby league, rugby union, association football (soccer), American football, hockey, ice hockey, lacrosse, squash, boxing, basketball, cricket, horse riding, martial arts). The same tick list was presented in a *genetic risk* section “If a genetic test suggested your child was at risk of long term (negative) effects (e.g. an increased risk of developing dementia in later life) following a concussion, select which contact sports you would let them play” and a *gender* item “If you were advised that the biological sex of your child was more at risk of long term effects (e.g. an increased risk of developing dementia in later life) following a concussion, select which you would let them play”.

An open-ended question at the end of this section asked participants to “Please tell us what you considered when answering the above questions (i.e. the most important deciding factors)”

Sport Injuries: Participants were asked to record their concern regarding ten potential sporting injuries (knee, arm, ankle, spinal, groin, leg, foot, head/neck, abdomen, face) on a four-point Likert-type scale from “very unconcerned” to “very concerned”. The list of potential injuries was based on common injuries caused by a variety of sports reported by a multi-disciplinary clinical team over a 12 month period (Baquie & Brukner, 1997).

Sport Participation Benefits: Participants reported on how much they believed in a list of nine potential benefits of their child playing sports, using a six-point Likert scale ranging from “A great deal” (6) to “None at all” (1). The following were included:

developing sportsmanship, team work, general health, mental health, sense of achievement, career potential, friendship/socialising, improved self-esteem, and improved cognitive performance. These benefits were based on a review of UK children's and adult's reasons for participation in sport and physical activity as demonstrated via published and grey literature between 1990-2004 (Allender, Cowburn, & Foster, 2006).

Concussion Attitudes: These were measured using the Rosenbaum Concussion Knowledge and Attitude Scale Student Version (RoCKAS-ST) Section 3 (Rosenbaum & Arnett, 2010). This scale comprised eight statements regarding sports concussion, answered using a 5 point Likert scale ranging from "strongly agree" to "strongly disagree". Five items (items 1,2,5,6, and 7) were utilised in the calculation of a concussion attitude score, whilst 3 items (3, 4, and 8) served as irrelevant distractors. Attitude statements included "I feel that coaches need to be extremely cautious when determining whether an athlete should return to play" (p.54), and "I feel that an athlete has a responsibility to return to a game even if it means playing while still experiencing symptoms of a concussion." (p.54) (See Appendix E)

Concussion Knowledge: A collection of 26 concussion knowledge related statements from a previous UK public survey (Weber & Edwards, 2012) were included. These were True/False questions answered using a 5 point Likert scale ranging from 'certain it's true' to 'certain it's false'. Example statements included: "An SC (sports concussion) is harmless and never results in long-term problems or brain damage" (p.358), "An SC can cause brain damage even if the sports person is not knocked out" (p.358), and "Once a recovering sports person feels "back to normal," the recovery process is complete" (p.358). (See Appendix F)

General Health Risk Taking Attitudes: The Domain-Specific Risk-Taking Attitudes (Adult) Scale (DOSPERT-30) (Blais & Weber, 2006) asks participants to respond on a seven-point likert scale, how likely they would be to engage in a range of described activities or behaviours ("extremely unlikely" – "extremely likely"). The complete assessment divides risk-taking responses in to five categories: Ethical, Financial, Health/Safety, and Social. Only the Health/Safety category statements were included in this survey in order to reduce fatigue effects. These six statements included: drinking heavily at a social function, engaging in unprotected sex, driving a car without a seatbelt, riding a

motorcycle without a helmet, sunbathing without sunscreen, and walking home alone at night in an unsafe area of town.

The DOSPERT-30 scale was developed through exploratory and confirmatory factor analyses, and has demonstrated good internal consistency reliability and moderate test-retest reliability (Blais & Weber, 2006). Evidence has been provided for convergent/divergent validity with regards to related constructs (sensation seeking, dispositional risk taking, intolerance for ambiguity, social desirability) and construct validity has been assessed via e.g. correlations with a lab-based risky gambling task.

Information Sources: Participants were asked to tick as many as appropriate when asked: "From where have you gained information on concussion/sports concussion/mild brain injuries, and their potential consequences?" Options included: newspapers, magazine articles, books, pamphlets, television, documentary, Internet article, Internet blog, social media (eg. Twitter, Facebook), non-sport medical professional (e.g. A&E doctor), sports coach/medical team member, sports player, friends or family, or other.

Services: Three open-ended questions asked if parents were aware of any national or local services that they could access for concerns regarding: dementia, concussion, genetic risk/screening/testing.

Medical Literacy: The MEDical TErM Recognition Test (METER) (Rawson et al., 2010) is a brief self-administered measure of health literacy consisting of 40 medical words (e.g. Arthritis, potassium, exercise, nerves) and 40 non-words (eg. irrity, inlest, alcoheltose, abghorral). Participants were instructed to select only the words that they were certain are real medical words, which takes on average two minutes to complete. METER has demonstrated high internal consistency and correlates highly with the longer REALM (Rapid Estimate of Adult Literacy in Medicine) measure, which involves reading out each word (Rawson et al., 2010). It has been significantly associated with various health-related measures including measures of neuropsychological function and cardiovascular health. Due to a question presentation error, some words were not displayed in the survey including both medical words, and non-words. As this was a small proportion the measure has still been included for informational purposes but may not reflect the same level of reliability and validity as the original scale.

Part 1: Parental Concussion Attitudes, Knowledge, and Predictors

Results

Data was compiled in Microsoft Excel, and analyses were conducted in SPSS (Statistical Package for the Social Sciences, Windows Version, <https://www.ibm.com/analytics/data-science/predictive-analytics/spss-statistical-software>). Concussion knowledge and Concussion Attitude answer scales were collapsed for calculation of correct/incorrect and safe/unsafe total scores. Football and Rugby (combined union and league) were coded individually due to their high participation rates in the UK (Sport England, 2016), and prominence in sports related concussion research and the media (Brisbourne, 2017; Shearer, 2017).

Concussion and Dementia Experience, Knowledge, and Attitudes

Total concussion knowledge scores from the set of 26 concussion knowledge questions were calculated, participants demonstrated a concussion knowledge score of on average 47.98% correct ($M=12.47/26$, $SD=4.65$). A logistical regression, looking at predictors of concussion knowledge produced a significant model ($\chi^2(11) = 39.66$, $p = .000$ ($\text{Exp}(B)=.819$, $SE=.116$) contributed to by four significant variables; Parent gender $W(1)=3.84$, $p=.05$ ($\text{Exp}(B)=.529$, $SE=.325$), Child mTBI experience $W(1)=5.45$, $p=.02$ ($\text{Exp}(B)=.458$, $SE=.335$), Concussion Attitude score $W(1)=17.724$, $p=.000$ ($\text{Exp}(B)=.332$, $SE=.262$), and Medical Literacy $W(1)= 10.96$, $p=.001$ ($\text{Exp}(B)=.416$, $SE=.265$). Parent mTBI experience, risk behaviour, sport benefits beliefs, injury concern, family history of dementia, years of education, and parent age were not significant contributors. Female gender was linked to lower concussion knowledge (-.637 times), not having child mTBI experience linked to lower concussion knowledge (-.781 times), lower medical literacy scores were linked to lower concussion knowledge (-.874 times), and poorer concussion attitudes (i.e. less safe attitudes) were linked to lower concussion knowledge scores (-.1.102 times).

Total concussion attitude scores were calculated from the ROCKAS-ST, with participants selecting on average the “safer choice” options in 61.04% ($M=21.37/35$, $SD= 3.37$) of the cases. Fifty-two-point-two percent of respondents had some

experience of personal mTBI, whilst experience of at least one child mTBI was reported in 18.8% of respondents. Twenty-eight and a half percent of surveyed parents reported a family history of dementia.

Predictors of Allowing Child/ren to Play Contact Sports

Of 311 parents who responded to this question, 85.9% reported allowing their child to play association football and 41.6% rugby (league and union combined) in normal circumstances.

Three logistic regression analyses were performed, with survey responses for 12 variables re-coded into binary categorical values based on median splits in order to satisfy the assumptions of the regression. "Injury Concern" was coded as "Low" or "High" based on summed scores for all injury categories (1= concerned, 2= very concerned). "Sport Benefits" was coded as "Low" (1-29) or "High" (30+) based on summed scores from all benefit categories (0= none at all, 1= a little, 2= a moderate amount, 3= a lot, 4 = a great deal). Four cases were removed as a result of incomplete answers, which could alter the sum score. General Risk Taking Attitudes (from the DOSPERT) was coded as "Low" (1-13) or "High" (13+) based on summed scores across all statements (1= extremely unlikely – 7= extremely likely). Three individuals were removed as a result of partial data, which could alter the sum score. "Concussion Attitude" was coded with summed scores across the five questions (Safest response/highest score on scale of 1-5: Q1. Strongly disagree, Q2. Strongly Agree, Q5. Strongly Disagree, Q6. Strongly Disagree, Q7. Strongly Agree.)

(a) Football (soccer)

A binary categorical logistic regression was performed to investigate the effects of several factors on "Allowing participation in (association) Football": parent gender, parent mTBI, child mTBI, concussion knowledge, concussion attitude, risk behaviour, medical literacy, sport benefits, injury concern, family dementia, parent age, parent years education. The overall regression model just failed to reach significance, $\chi^2(12) = 19.149$, $p = .085$ (Exp(B)=8.030, SE=.185)

Significant individual variables in the model were "Concussion Attitude" ($W(1) = 3.848$, $p = .050$, $\text{Exp}(B) = 2.294$, $SE = .423$), with a high (relative to low) Concussion Attitude

safety score (i.e. reflecting a more positive attitude to safety) being 2.294 times more likely to result in a “Yes” response to Allowing participation in Football, and “Injury Concern” ($W(1)= 7.571, p=.006^*, \text{Exp}(B)=.315, \text{SE}=.419$), with a high (relative to low) Injury Concern score being .315 times less likely to result in a “Yes” response to “Allowing Participation in Football”.

(b) Rugby

A binary categorical logistic regression was performed to investigate the effects of several factors on “Allowing Rugby”: parent gender, parent mTBI, child mTBI, concussion knowledge, concussion attitude, risk behaviour, medical literacy, sport benefits, injury concern, family history of dementia, parent age, parent years of education. The regression model was significant, $\chi^2(12) = 28.610, p = .005$ ($\text{Exp}(B)=.753, \text{SE}=.117$)

Significant variables in the model were “Risk Taking Attitudes” (DOSPERT scale total scores) $W(1)= 5.942, p=.015^*$ ($\text{Exp}(B)=1.854, \text{SE}=.253$), in which a “high” relative to “low” Risky Attitude score was 1.854 times more likely to result in a “Yes” response to “Allowing Rugby”. “Medical Literacy” $W(1)= 4.115, p=.043$ ($\text{Exp}(B)=1.721 \text{SE}=.268$) which, when higher, is 1.721 times more likely to result in a “Yes” response to “Allowing Rugby”. Lastly “Sport Benefits” $W(1)= 5.342, p=.021$ ($\text{Exp}(B)=1.774, \text{SE}=.248$) where a “Yes” response to “Allowing Rugby” was 1.774 times greater with a high benefits rating, and “Injury Concern” $W(1)= 6.958, p=.008^*$ ($\text{Exp}(B)=.513, \text{SE}=.253$), where a high relative to low concern score was less likely to result in allowing rugby by .513 times.

(c) Sports Allowed

A binary categorical logistic regression was performed to investigate the effects of several factors on “Sports Allowed”: parent gender, parent mTBI, child mTBI, concussion knowledge, concussion attitude, risk behaviour, medical literacy, sport benefits, injury concern, family dementia, parent age, parent years education. The regression model was significant, $\chi^2(12) = 27.674, p = .006$ ($\text{Exp}(B)=.851, \text{SE}=.116$)

The significant variable in the model was Injury Concern $W(1)= 11.990, p=.001^*$ ($\text{Exp}(B)=.418, \text{SE}=.252$), where a “high” relative to “low” score was less likely to result in the selection of a high number of Sports Allowed (.418 times). Near significance was

found for DOSPERT Risk Taking Attitudes $W(1) = 3.621, p = .057$ ($\text{Exp}(B)=1.612, SE=.251$) with a high (relative to low) risk score linked to a 1.612 times greater likelihood for a high number of Sports Allowed.²

The Impact of Potential Genetic and Gender Associated Risks

The number of contact sports parents said they would allow their child/ren to play under normal circumstances ($M=6.513, SD=4.028$) was significantly higher than the number they would allow them to play if they (i.e. the children) were at increased genetic risk of long-term cognitive/health consequences following concussion ($M=4.609, SD=3.923$) in a Wilcoxon Signed Ranks test ($z=-10.201, p=.000$).

Parents were significantly more likely to say respond “yes” to allowing their child/ren to play football in normal circumstances ($N=275, 85.9\%$) than saying respond yes to allowing them to play football if they (the children) were at increased genetic risk of long term cognitive/health consequences following concussion ($N=190, 59.4\%$) in a Wilcoxon Signed Ranks test $Z=-7.353, p=.000$.

Parents were significantly more likely to say respond “yes” to allowing their child/ren to play rugby in normal circumstances ($N=133, 41.6\%$) than saying respond “yes” to allowing them to play rugby if they (the children) were at increased genetic risk of long term cognitive/health consequences following concussion ($N=63, 19.7\%$) in a Wilcoxon Signed Ranks test ($Z=-7.298, p=.000$).

The number of contact sports parents reported they would allow their child/ren to play under normal circumstances was significantly higher than they would allow them to play if they were at biological gender-based increased risk of long-term cognitive/health consequences following concussion in a Wilcoxon Signed Ranks test ($Z=-9.790, p=.000$). Parents were significantly more likely to say respond yes to allowing their child/ren to play football in normal circumstances than saying yes to allowing them to play football if they were at biological gender-based increased risk of

^{2*} following equations in the above represent a significance level passing Bonferroni correction for multiple comparisons within these 3 regression models ($p=.0167$).

long term cognitive/health consequences following concussion in a Wilcoxon Signed Ranks test ($Z=-7.416$, $p=.000$). Finally, parents were significantly more likely to say respond yes to allowing their child/ren to play rugby in normal circumstances than saying yes to allowing them to play rugby if they were at biological gender-based increased risk of long term cognitive/health consequences following concussion in a Wilcoxon Signed Ranks test ($Z=-6.303$, $p=.000$).

Discussion

I conducted a survey of parents with children under the age of 18 to assess concussion knowledge and attitude, and predictors of behaviour, i.e. of which contact sports they would allow their child/ren to participate in. I aimed to create a model of predictive factors for allowing participation overall, in football, and in rugby in three conditions; normal circumstances (i.e. general risk), in the context of increased genetic risk, and in the context of increased biological gender-based risk.

Overall, rather low levels of concussion knowledge and lax safety attitudes were found (parents frequently choosing less safe responses), contributing to previous conflicting findings relating to awareness, attitudes, and knowledge in parents (Bloodgood et al., 2013; Mannings et al., 2014; Sullivan et al., 2009). Lax attitude findings may be due to the use of a single attitude measure, or more likely, the use of a broader online recruitment method. Previous work, such as (Sullivan et al., 2009) for example, recruited parents through attendance at their child's sporting events. Participants observing their children participating in sport may have been more involved and aware of concussion signs, prevention, and management through observation, interaction with coaches and staff, or discussion with other parents. With concussion knowledge scores under 50% correct on average, this study further highlights the need for effective concussion awareness initiatives. This is particularly important when considering a TRA/TPB (Ajzen, 2011) model of attitude formation, in which multiple factors can have an influence; poor knowledge and attitudes in parents could influence their children's behaviour and the priorities of coaches or policy makers. The importance of this is supported by the current finding that more lax concussion attitudes predict lower concussion knowledge scores (or vice-versa). However, higher medical literacy and personal experience of their child having an mTBI were also

predictors. This reflects previous work finding greater concussion scores associated with experience of mTBI (Cusimano et al., 2017). Potentially, knowledge is higher in parents who have had to look for information following an incident and have the medical literacy to benefit from available literature. On the other hand, parents who have higher knowledge of concussion may be more likely to recognise symptomology in their child. If findings were to be applied to communications and knowledge transfer initiatives in the future, the potential link between gender and concussion knowledge, suggests information needs to be adapted for individuals. Since female parents presented with lower scores, they may benefit in particular from any such initiatives.

Parents were more likely to allow children to play football (soccer) than rugby, choosing to allow their child/ren to participate in roughly half the contact sports listed. This suggests parents consider football a less 'physically risky' sport. The increase in media and research interest in football-related concussion risks (e.g. the recent BBC Alan Shearer documentary "Dementia, football, and me" (Shearer, 2017)) has been arguably more recent and less salient than in rugby. Recent work suggests the potential for negative effects of tackling and heading in the sport (Kontos et al., 2017). However rugby in schools appears to present a lesser actual risk than indoor football and a near equal risk to outdoor football (see Figure 5-1) (Quarrie et al., 2017). Instead the authors of that paper suggest that management factors play an important role, with injury risk in child rugby linked to tackle technique.

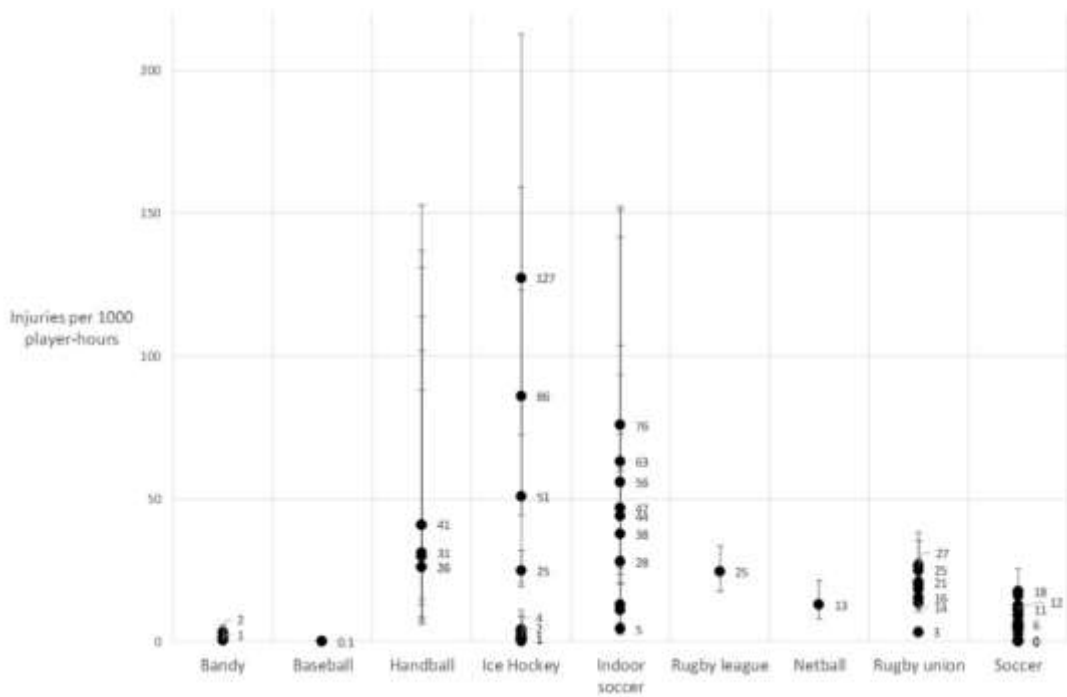

Figure 5-1. Match injury rates for children's sports from Quarrie et al., 2017, p.1137

Whilst an overall significant model of predicting factors in choosing to allow a child to play football was not found, there appeared to be a role of safe concussion attitude scores and lower overall injury concern. This finding is generally, although not fully, consistent with the predictions of TRA/TPB, in which specific (rather than general) attitudes/beliefs predict intentions. However, further work with additional measures of concussion attitudes would be beneficial. Scores in the attitudes scale in the included assessment could indicate the influence of other factors such as parental values regarding safety, which will be important to study in future investigations. Parents' decision to allow children to play football were influenced by a safer attitude score, suggesting parents consider football to be a safer choice in comparison to other contact sports. The potential influence of injury concern builds on previous work, which typically does not include this element. Inferences made from previous research, i.e. that parents are concerned about concussion in certain sports, may instead reflect a general concern for their child's safety and well-being whilst playing sports. Similar findings were seen for overall contact sport participation, with parents more likely to select a greater number of contact sports that they would allow their child to play if they scored low on overall injury concern, with the suggestion of an

influence of general parental health risk attitudes (as measured by the DOSPERT). Future work would benefit from inclusion of a further assessment of general risk attitudes and traits (including values), with the aim to investigate the influence of concern for their child's well-being outside of a sporting context. If this were to be the case, services or initiatives aiming to alter attitudes towards contact sport safety may have to broaden their aims to other potential health risks in order to have a greater effect. This would however, argue against a strong TRA/TPB model in which the best predictor of behaviour is argued to be more specific behaviour-based attitude (such as allowing to play or reporting concussion). Meta-analysis work with TPB has found that it acts as a better predictor for self-reported behaviour than actual (i.e. observed) behaviour, suggesting caution is warranted when relying on self-report (Armitage & Conner, 2001).

There were some interesting differences between the factors influencing whether a parent would allow their child to play rugby vs. those factors influencing decisions regarding participation in football (soccer). A significant model predicting whether or not a parent would allow a child to play rugby was found, with contributions from general health risk-taking attitudes (DOSPERT), higher general medical literacy, higher belief in the benefits of sports, and lower concern for other potential injuries predicting increased likelihood of allowing a child to play rugby, but not, notably concussion-specific attitudes. Again, these results are partly consistent with the TRA/TPB. It appears parents who would allow their child to play rugby demonstrate heightened risk preferences in general, including fewer concerns linked to child injuries, and a stronger belief that the benefits of rugby are worth the potential concussion risk (see Carson 2017). Importantly, higher medical literacy scores suggest that information on concussion and health risks in rugby is accessible to these parents, and they may be making an 'informed' decision rather than expressing simply an indiscriminate tendency towards risky behaviours. Some of the differences between rugby and football could reflect the more recent concerns over concussion in football. However, consideration of demographic details such as socioeconomic status in relation to accessible sports could play a role. It should be noted that the DOSPERT risk behaviour attitude assessment used in the present study consisted of questions regarding risky acts performed by the parent as an individual, not of themselves as a

parent or including their children. However, it appears from this data that the general risk-taking behaviour attitude of the parent as an individual, effects risk behaviour (or attitudes), when applied to their child/ren. This could again link back to a life-span model of cognitive health, as sensation seeking behaviour (the general propensity to take physical risks) has been associated with genetics through work with twins (Zuckerman, 1983). It is possible, therefore that the children of risky parents are genetically predisposed to risky sport participation, independent of (or in interaction with) any social learning effects. Future genetically informed studies of attitudes to risky contact sports in parents and children could examine this.

Expanding on previous work to include a comparison between factors influencing participation in football vs. rugby allows for a greater understanding of potential influences of attitudes and behaviours in parents. With the finding of a significant model predicting allowing a child to play rugby but not for playing football, it implies either a different range of impacting factors is relevant to each case, or that football is reacted to more homogenously, potentially considered less of a risk and more commonly accepted sport by parents and society. This further supports the development of targeted awareness initiatives in different sports.

When parents were asked to complete the same attitude-behaviour assessment with regards to the consideration of increased genetic risk or biological gender risk to adverse effects of concussion, the number of contact sports they would allow their child to play was significantly lower than in the 'normal' (i.e. non-specified risk) circumstances. Parents were also significantly more likely to allow children to participate in football and rugby if they were not at increased genetic/gender-based risk of long-term cognitive/health consequences following concussion. I am unaware of any literature to date considering the influence of potential genetic risk on parental decision-making regarding participation in contact sports. Parental gender has been linked to attitudes (Bloodgood et al., 2013), but is typically not portrayed or emphasised as genetic (i.e. biological sex) but rather in relation to social gender norms. Feelings and actions towards increased genetic risk has of course frequently been studied in relation to genetic counselling – for example in relation to genetic disorders such as Huntington's disease (Meiser & Dunn, 2000) – but is likely to become

increasingly salient with the advent of direct-to-consumer genetic testing and increased scientific knowledge of gene-environment interactions that influence large numbers of human behaviours linked to long term adverse outcomes including concussion. My finding suggests that knowledge of genetic risk is likely to play a key role in parental decision-making with regards to sports participation and should be the focus of future study.

The second part of this analysis focuses on using a qualitative approach to tackle this genetic risk topic, in addition to elaborating on the thought-processes behind parent's decisions in the above closed-questions context. With research often failing to predict behaviour (Madill & Gough, 2008), a need for an understanding of deciding factors in order to produce effective awareness materials, and lack of significant findings in the above predictive models suggesting some important variables may have been unmeasured – this mixed methods approach is vital and could inform future development of the quantitative measures.

Part 2: Parental Considerations Towards Child Participation in Contact Sports: Thematic Analysis

Methods

Participants

Three-hundred and five parents (237 female, 64 male) chose to respond in some way to the open-ended question, average age 37.43 years (SD=9.25 Min=19, Max=72).

Procedure

This study used thematic analysis of a short open question where parents were asked to describe “What did you consider (when answering)?” following three tick-box selection questions in the survey. The questions asked parents (a) to select which contact sports they would allow their child/ren to play in normal circumstances (i.e. with no specified risk); (b) If their child were at increased genetic risk of an adverse concussion response, and (c) If their child were at increased risk of remote concussion effects as a result of their biological sex.

Thematic Analysis is a qualitative technique developed from Content Analysis (Joffe, 2012) allowing the reporting of themes and patterns within data (Braun & Clarke, 2006). The method takes an active approach in which themes do not ‘emerge’ but are actively pulled and formed by the coder. Individual themes identified aim to express important aspects of the data in relation to the research area and questions, and whilst multiple cases representing a theme lend to it being a pattern within the data, theme frequency per se does not necessarily represent the importance of the theme (Braun & Clarke, 2006).

The thematic analysis was completed within six steps guided by the recommendations of Braun and Clarke, 2006:

1. Familiarisation with the data: the coder and author re-read the data multiple times and constructed a rough “memo” (see Figure 5-2)
2. Generating initial codes: the collation of all data with various initial codes.

3. Searching for themes: the combining and collation of codes in to several key themes and sub-themes.
4. Reviewing themes: extracted data for each theme were checked for consistency and patterns within and across themes. A thematic map was constructed.
5. Defining and naming themes: themes were refined, with clear definitions and names for each within an overall 'story' of the data.
6. Producing the report: definitions and reflections on each theme were provided, with the use of informative and representative example extracts from the data.

The frequencies of coded extracts per theme were not reported as is done in Content Analysis, which is sometimes described as 'trite' and missing subtle and complex elements in data (Joffe, 2012). The aim was to report on underlying implicit themes.

This study used a primarily inductive approach, with no prior model or coding frame. The data acted as the source of a coding frame. This has been described as providing richer overall analysis (Braun & Clarke, 2006) and is related to grounded theory (Henwood & Pidgeon, 1992). However, due to the potential of me having preconceptions, a reflective statement was also added in which my relevant history is described. The inclusion of a reflexivity statement allows for a greater understanding of the influence that my values, experiences and interests may have had on the identification and reporting of themes (Henwood & Pidgeon, 1992).

Data was collated in Microsoft Excel before transfer to NVIVO software (Richards, 1999) for coding. All coding was completed by myself. Cohen's K was run to determine if there was agreement between myself and an independent secondary coder on a 10% subset of statements. Three themes were randomly selected for analysis. Results suggest moderate overall inter-rater reliability but vary between themes. Personal experience $K=.634$, $p=.000$. Information seeking $K=1.000$, $p=.000$. Health $K=.333$, $p=.014$.

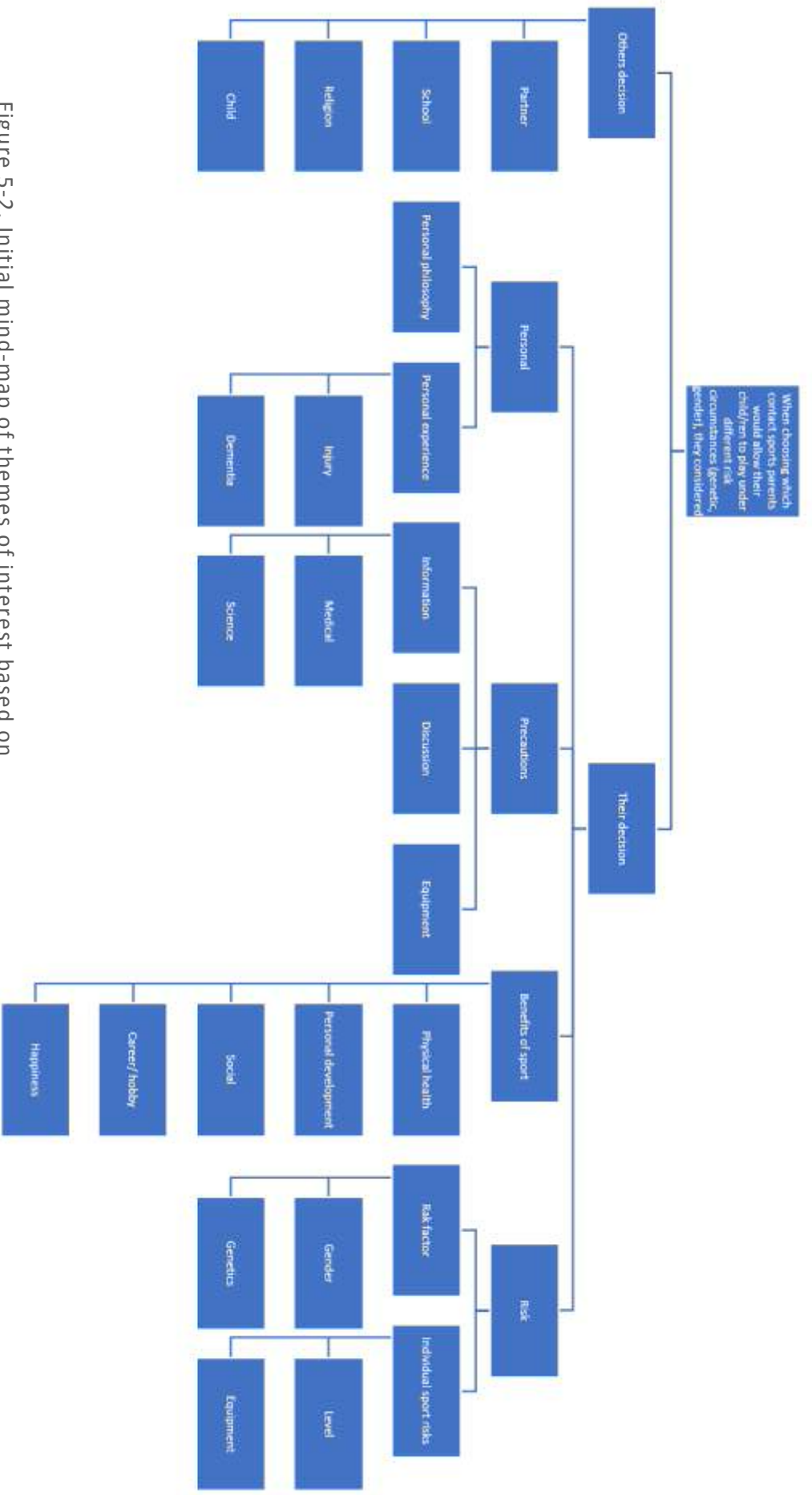

Figure 5-2. Initial mind-map of themes of interest based on familiarisation with the data.

Reflective Statement

I have been involved in concussion related research for approximately 5 years, with a history of clinical neuro-rehabilitation work, research suggesting changes in neural structure following concussion, and science communication and policy experience. Whilst I have familiarised myself with the data and aimed for a neutral approach, I acknowledge that aspects of my personal experience and beliefs are likely to have influenced the identification of themes drawn from the analysis. I do not currently have children, although I do have a younger sibling. I do not regularly participate in any listed contact sports, and do not watch contact/non-contact sports. I have personal experience of severe/mild concussion and dementia through friends and family, but no direct experience with genetic counselling or genetic testing. The process of familiarisation with data was done over several weeks, with the repeated major theme of *'lack of control'*, use of *'common sayings'* (i.e. maxims), and discussion of particular sports appearing most salient. The general impression obtained from familiarisation with the data was concern for the effectiveness of current attitude and awareness initiatives; with the lack of control many parents feel; and an appreciation of parental efforts to consider both the risks and benefits of contact sports.

[Key Themes, Results and Discussion](#)

The below thematic map (see Figure 5-3) represents the final collection of themes present in the analysis, including sub-themes and any prominent links (e.g. between 'A lack of control- third party and future' and 'Personal beliefs')

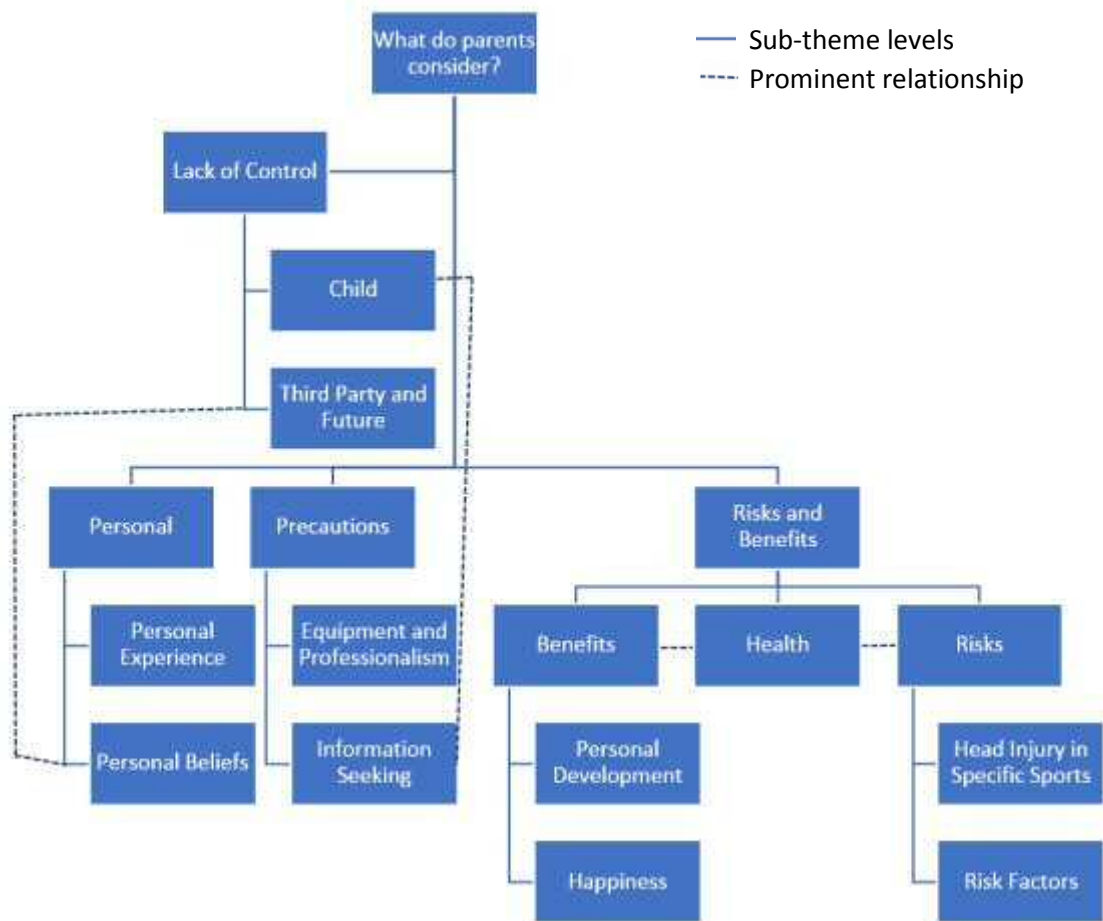

Figure 5-3. Final version of analysis themes model, including sub-themes, and prominent relationships.

(a) Lack of Control

In asking parents what they would consider in relation to deciding which sports they would allow their child/ren to play, the first distinction between answers was whether parents thought it was their decision in the first place. Some parents responded that it was not their decision to make, describing the decision of which sports to play as belonging to someone/something else (e.g. the child themselves). This was unexpected and a factor that had not been raised in previous work, which often only asks for a yes/no response to similar questions, without clarifying if participants believe it is their choice anyway.

Not included in this theme were parents who made comments suggesting the role played by their child or by medical professionals in the decision but mentioned it in the context of consideration in their own decision-making. For example

“However, if my children really wanted to try a particular sport I would definitely consider letting them.”

This ultimately leaves the decision to the parent with only input on preference from the child and as such would not be coded in Lack of Control (Child). This instead would be coded under the Benefits theme, showing a parental consideration for the child’s happiness and requests in the decision-making process.

“I’d take advice from the doctor and see where to go from there.”

The parent here references seeking a medical professional’s opinion, but this is framed as advice that the parent would use in their own decision making. As such this is not coded under Lack of Control (Third Party), but instead in Precautions (Information Seeking). They propose that beyond the answers provided in the questionnaire, in real life they would first seek further information before deciding concretely. The demonstration of parental feelings of lack of control links to a key component of the TPB model (perceived behavioural control) (Ajzen, 1991) and also raises important considerations for future development of impact initiatives. A feeling of a lack of control could influence decisions and the effectiveness of awareness, knowledge, or attitude adjustment projects.

(b) Child

For parents who described the decision as belonging to another, the most common was the child themselves. Parents consider the free will and agency of their children, in addition to not personally acting as a hindrance;

“If it’s what my child wanted [to] do I wouldn’t be the one to stop them.”

“I will not stop my son living his life.”

“My child’s free will to make their own decision.”

However, those that mentioned the independence of their child, may also refer to providing guiding information or supporting an educated decision. For example:

“That choices regarding sports/activities will be my daughters decision, not mine. I can only make her aware of the risks, but ultimately it is not my decision to make.”

“That my children are old enough to decide by themselves, when presented with the evidence.”

“I would prefer my child to make an educated decision when they were old enough about their own welfare and participation.”

“I would like to think that I will bring my daughter up in such a way that she will make informed decisions based on the information she has.”

“I think at an older age he can decide for himself what to do, knowing of the condition. But for now his brain is still in development so I want to protect him.”

“I can only make her aware of risks, but ultimately it is not my decision to make.”

Parents highlighting the age of their child as a key factor in their decision-making process supports previous work demonstrating differences in parental awareness and attitudes regarding concussion. Bloodgood et al. (2013) described how awareness of concussion and seeking of information was highest amongst parents with pre-teen children. They believed this was due to the increased salience of the risk as children transition to more high-contact sports. However, that study did not consider the increased agency children may also develop or be considered to have by their parents at this older age. An increase in awareness and information seeking in parents of older children may not directly transfer to increased safety behaviour or informed decision

making in the child. Instead applied work could aim to include educational activities in schools or targeting the children themselves. Research has raised the role of social norms regarding sports (Sanderson et al., 2017), and attempts to influence the overall peer culture could lead to safer behaviour independently or in collaboration with parental influence.

A more tentative link can be made between this theme and that of Precaution, as the parents above demonstrate considering their children to have the information necessary in order to make the most appropriate decision. They suggest input through making their children aware of the risks, however, relying on children having the best information and ability to make sense of it. This supports models of attitude formation described where multiple stakeholders have a role. In order for children to form a safe attitude to risk and engage in safety behaviours they would require input from many sources such as medical staff, parents, coaches, peers and policy/administration.

(c) Third party or Future

There were a few references to decision-making forces beyond the parent and child. Some were more 'direct', describing a third-party identity that would have the influence to decide.

For example;

"On a side note my husband will not let my son do boxing because of the worries of brain injury."

to school;

"-They would play these at school etc. so you can't really get away from them."

and religion;

"We are Christians and trust God that if it wasn't right for one of our children to play a particular sport, he would tell us."

Whilst some were less 'direct', potentially describable as uncontrollable elements that could play a role in their child's life and hence take the decision out of the parents or child's hands. Notably, these included genetics;

“If genetics influence dementia it doesn’t matter what protection I put in place.”

And the concept of an unpredictable future or fate;

“Just because there may be an increased risk doesn’t mean it will definitely happen.”

“I can’t control what happens in later life.”

“No one knows the future but God.”

Parents also reference how they cannot control for the risk of concussion or potential negative long term health effects as they can occur elsewhere despite not participating or taking precautions in contact sports:

“My child could just as easily suffer concussion in day to day life.”

“Dementia can happen to anyone with or without sports.”

“What sports I would let them play wouldn’t have an impact on the potential chances of dementia. They could get hit by a bus at any time, so I would want them to enjoy life and do what they want.”

“A concussion could occur in many circumstances.”

With descriptions of decisions being ‘taken out of their hands’ by fate and other risk scenarios, there is potential for parents to instead resign themselves to taking no precautionary measures. Such adverse effects of misunderstanding related to science and health has been referred to the context of genetics as ‘genetic fatalism’ or ‘genetic essentialism’ (Dar-Nimrod & Heine, 2011). Heine, Dar-Nimrod, Cheung, & Proulx, (2017) described how people tend to think of an individual’s genetic make-up as an immutable natural determinant of one’s life and a method of categorising in to clear-cut groups. This is a potential risk for a fatalistic attitude in which no effort is made to change health circumstances, despite the proposed multiple influences and interventions described in life-span models (see General discussion for further discussion of this issue). Future research may benefit from including not only a medical literacy assessment as in the present study, but also having a genetics literacy assessment. Higher scores on such a measure have been linked to weaker fatalistic/essentialist tendencies (Heine et al., 2017), and could act as a predictor for

behavioural changes (safety equipment, recovery management) relevant to avoiding concussion or long-term negative effects.

(d) Personal

Several varied comments fit a more personal theme, relating back to family or friends with injuries or dementia, or the utilisation of personal sayings and philosophies (i.e. maxims or adages).

(e) Personal Experience

Participants expressed personal experiences as influences of their decision-making, describing injuries;

“I have an older son (over 18) who has had to have surgery twice now on his shoulder which kept subluxing so I’d be reluctant to allow it again.”

dementia;

“My mother has dementia, so I have experience of how awful the disease is and would not intentionally do anything to increase my risk of getting dementia, or the risk of my children getting it.”

“After recently losing my grandmother to dementia and seeing the impact it has on her life, I would be hesitant to let my children be involved in games where they are at great risk of head injury. I would not like them to suffer dementia later in life.”

and concussion awareness;

“I follow NFL [National Football League in North America] a lot and know about the diagnosis of CTE and how concussions can effect people later in life.”

Personal experience also extended beyond that with health and safety factors, including parents’ experiences and current or previous contact with various sports. For example;

“They are sports my family coach.”

“I watch and have had a great deal to do with horses in the past so feel it’s a risk”

“Which sports from the one[s] he currently plays that have the least physical contact.”

The latter highlights the importance of multi-method research, as participants choosing not to select certain sports in relation to quantitative questions on what they would let their child play, might not be a reflection of their attitudes towards the sports or risk but instead be interpreted as irrelevant.

(f) Personal Beliefs

Personal beliefs connects with several elements of the thematic model, but was formed in to a distinct sub-theme due to the thread of repeated use of ‘common sayings’. Parents frequently fall back on such sayings and folk wisdom or maxims and adages, which are distinct from actual personal experiences or concrete opinions on sport benefits or equipment use. Some were common concepts or expressions in popular culture such as;

“Life is too short.”

“You only live once.”

“-Living for the moment, not the future.”

“-There is no point living in fear.”

“-You can’t live your life constantly worrying about the what if happens.”

“Because we must live our lives to the fullest, our time could be up tomorrow and we must do the things we want to do”

“You can’t live your life on what ifs otherwise you wouldn’t do anything.”

An expression regarding ‘wrapping your child in cotton wool’ was especially popular as a description of not being overly risk-averse or controlling of children;

“You can’t wrap them up in cotton wool about something that might happen”

“I just thought about the fact that you can’t wrap your kids up in cotton wool and you can’t live our life not doing things because there’s a chance that something might happen in the future. Life is for living.”

"You may not live to old age- while you should be cautious you cannot wrap children in cottonwool "just in case"."

"Of course you would want to "wrap your child in cotton wool" but this is unfair to them."

Others were slightly less 'clined' descriptions of personal philosophies or opinions on their child's safety and well-being;

"I understand the risk to be low and consider taking calculated risks an important factor in life."

"I do not feel that a child should be stopped doing something for something which may happen in the future."

"Cut them [contact sports] out altogether- Life's not worth risking for sport."

"They are still only children so should still live a child's life."

These considerations and maxims are likely acting as a broader (summary) attitude assessment. It is possible that, unlike Personal Experience examples such as concussion or dementia history in the family, they instead represent how parents would react in a variety of situations. The representational role of such maxims has previously been identified in Leventhal's "common sense" model of self-regulation of health and illness (Leventhal, Leventhal, & Breland, 2011).

Importantly, whilst separate from Lack of Control, a connection between the two can be drawn. A parent considering their child or a third party such as God as deciding relies on their personal beliefs in their child's independence or a spiritual existence. There is a link between these personal beliefs and lack of control with parents describing how

"something could happen later in life"

Or choosing to be less or more cautious on

"a chance something bad happens later".

Some of the parent's broader personal beliefs relate to a general lack of control, again suggesting views of genetic determinism and fatalism (see general discussion).

(g) Precautions

A particular focus on precautions was evident, where the risks and benefits were discussed in the context of precautionary measures such as safety equipment, information sourcing, or discussion with the child.

(h) Equipment and Professionalism

Parents frequently referred to precautionary measures that they currently used in contact sports, or would consider necessary for safety in hypothetical circumstances.

“I use caution and I always use safety precautions such as helmets and other gear”

“I would just make sure they had the right safety equipment.”

Some parents mentioned professionalism factors such as adapting to make the contact sport safer;

“Obviously many sports have low contact versions for younger children.”

“-As long as areas of participation were professional and safe.”

Precautionary considerations were mostly equipment or withdrawal related, suggesting poor awareness of concussion management for healthy safe participation in contact sports. Consideration of concussion symptom identification and management factors, such as return-to-play guidelines, were not expressed. With research suggesting little benefit of equipment such as helmets in contact sports (Harmon et al., 2013), parental reliance on such measures may not be the safest method. An interest in professionalism and adaption of sports does however suggest parents are aware of the need for training of sport staff (coaches and administrators) in safety management.

(i) Information Seeking

Parents report a need for further information, proof, or reliable information sources. For example;

“I would need to know exactly what risk there was of concussion leading to dementia. Also what evidence of concussion being caused by specific sports?”

“If I was told they had a 90% chance of dementia then I might re-think, but without further detail I cannot make an informed decision.”

“I’d take advice from the doctor and see where to go from there.”

“If I had proof my child was more likely to suffer difficulties I would encourage noncontact sports.”

“Who was advising me and what were they basing it on.”

The above considerations by parents highlight the need for reliable and readily accessible information sources. Such responses are likely induced by asking participants to choose which sports they would allow their child to play in differing circumstances. It suggests that parents would need precise details on the risk of concussion and convincing evidence of links with dementia in not only specific sports but in relation to individual differences such as genetics and gender. Such relationships between life-span health and these factors are unfortunately complex and unlikely to provide a clear, straightforward predictor a parent may require in order to take effective precautionary action. Instead, less scientifically robust but simpler information such as that presented in media may be utilised, potentially leading to inappropriate responses.

(j) Risks and Benefits

When considering their own decisions, two frequently overlapping themes referred to either the benefits or risks of contact sports. Whilst this theme appears to be more sensibly divided in to two branches immediately rather than at a sub-level, it was decided the style of answers received would be better represented through combining the two. Within individual responses, parents often referenced both risks and benefits in sports, weighing between the two in the decision-making process. For example;

“What sport they would enjoy, the amount of contact.”

“Balancing child’s enjoyment and benefits of sport with risk to their long term health.”

(k) Health

Health acts as a bridge theme between Risks and Benefits, expressed in both ways by parents and, in some case, both by the same parent. Indeed, with some responses, it is not possible to distinguish without individual follow-up with participants, whether they were referring to health in a positive or negative context. For example, where parents simply mentioned;

“Health issues”

“Mental, physical effect”

This necessitated a joint Health theme as respondents could be referring to consideration of later-life health issues following a concussion (Risk) or a health benefit for the child from playing sports (Benefits). It is possible that parents were aiming to describe how they were considering all aspects of a child’s health, both potential negative effects of concussion and benefits of exercise together.

Parents’ concerns included concerns over long-term health effects of contact sports and concussions

“I wouldn’t want my child to have a larger risk of dementia or other health issues.”

“My child’s health in later life is more important than sports.”

“I decided the risk of head injury in the sports I did not choose were too big, I don’t want my child to get dementia.”

But also the health benefits of participating in sports, for example;

“Exercise-is also important.”

“Sports also provide many benefits such as fitness.”

“There are risks with everything. Playing sports brings with it so many advantages;- health and fitness- it outweighs the chances.”

“Whilst he may be at risk of later life issues, you have to live the life that you have and stopping him from doing a sport- which probably has many long term health benefits in case something happens later in life is pointless.”

“I consider the physical fitness.”

(I) Benefits

Parents consider the benefits of sports in several forms including health, safety, happiness, passion, personal development (sportsmanship, teambuilding), and career potential. These were sorted in to three key sub-themes.

It is important to note that in the wider context of the survey, participants were asked to respond on a Likert scale as to how much they believed in several potential benefits of sport; developing sportsmanship, team work, general health, mental health, sense

of achievement, career potential, friendship/socialising, improved self-esteem, and improved cognitive performance. This may have influenced participants' consideration of sport benefits or made certain named benefits salient at the time of writing. With frequent mentions of concussion and its negative effects throughout the survey, this increased salience of sport benefits may have decreased negative thinking about concussion, or highlighted benefits that parents may have otherwise not considered.

(m) Personal Development

Personal development in children frequently included social factors such as relationships with peers, sportsmanship, and teamwork;

"I would encourage any other sport [than boxing] even if there was some risk as I feel learning sportsmanship is important- being part of a team is also important."

"Sports also provide many benefits, such as- teamwork."

"Football and rugby are played at my local school I wouldn't want my child to feel different."

"Making friends, spirit of good competition."

Surveys and thematic analysis work with youth athletes has shown the potentially negative effects of social factors such as those described above (Sanderson et al., 2017). Peer pressure to fit in and not letting a team down can lead to under-reporting of concussion and incorrect management. A strong parental focus on not wanting their child to be left out and working as a team could, despite being considered as a positive, influence a child's attitudes and safety related behaviour.

Parent consideration also included contact sport as a potential career;

"My daughter plays at county level and hoping to progress further. It is her biggest passion in life."

Of interest, the potential self-defence benefit of some sports was highlighted, despite being listed as a contact sport in the survey. This was a particular personal development consideration in regard to sports such as martial arts.

"More to do with - what they benefit from (like martial arts is more about the sport and can be about personal development and safety."

“Martial arts is good to help them defend themselves knowing how to protect themselves from attackers.”

“-And I think that martial arts would have an emphasis on safety and learning how to react to an opponent in order to minimise or prevent injury.”

In these cases, parents are prioritising the risk of attack injuries (likely outside sports) over concussion injuries in contact sports. It would be of importance to consider what other risks parents see for their children and how attitude, awareness, and behaviour changes between them. When considering the role of information sources, it could be asked why such a risk is considered important, how it is presented by media and medical sources, and whether the likelihood of it occurring is statistically more significant than a contact sports injury.

(n) Happiness

A common theme in parents’ responses was the consideration of their child’s emotional well-being through happiness, passions, and desires to be involved in sports;

“Their happiness.”

“Am not going to stop them playing and enjoying what sports they like.”

“Childrens’ happiness and desire to try.”

“My daughters love of football would make me hesitant to stop her playing it”

(o) Risks

(p) Head Injury in Specific Sports

This represents a merging of two consideration response styles which frequently overlap. Parents would describe their decision-making process involving chance of head injury;

“I considered the chance of a concussion occurring in each sport versus the enjoyment my child gets from participating in each one.”

“Sports where there was less risk of getting knocked on the head.”

However, this is in the context of choosing which sports they would allow their child to play, rather than a simple expression of concern for head injury. It demonstrates calculation and consideration of risk specific to a sport.

Particular sports highlighted by parents as head injury risks were rugby and boxing;

“Rugby is quite rough so I wouldn’t let them play that.”

“I don’t agree with boxing as a sport so would never encourage my children to pursue it as a hobby.”

“I was concerned about boxing and blows to the head.”

“I feel rugby and boxing, especially boxing are too physical.”

These are arguably the two with highest publicity in the United Kingdom and several other English-speaking countries such as Australia and New Zealand (with American Football being more prominent in North America). The increased media focus on football concussions risks is relatively new (Brisbourne, 2017; Shearer, 2017), and some high-risk contact sports (horse-riding, ice-hockey) may not be accessible to high numbers of the population and as such are not salient or of strong importance to many parents.

Martial arts was also raised as a concern, despite safety and defence related benefits being cited in other parents;

“Boxing or martial arts may be too much of a rough contact sport which could likely cause concussion.”

Parents appeared to consider among others, football, as a low concussion risk and safer sport to allow their children to play;

“Football don’t really see the risk. Nor squash.”

“I consider basketball to have a relatively low risk of concussions.”

This was however not always the case;

“Football and hockey are too risky. While rugby is also risky, they generally have more care.”

Parents may acknowledge that some high-risk sports may have more well-established concussion protocols and as such be ultimately safer for their child.

Consideration of individual risk also included factors across sports such as the individual level of play;

“It would really depend on how competitive the league or team was.”

Parents may consider not just the head injury risk of a particular sport, but at what level that sport is played, and as such would benefit from tailored prevention and management advice.

With the discussion of the theme of individual sport risk consideration, it is important to highlight the broader context of the question within the overall survey, which consisted of multiple sections and predominantly quantitative Likert or multiple-choice style questions. Participants were potentially primed with selecting various contact sports (rugby, football etc.) and encouraged as such to make decisions between them rather than overall thoughts on contact sport participation per se. Parents who did not simply select all or none of the options would have likely considered each sports risks and benefits separately and been more likely to express specific opinions in this follow-up open-ended question. It is not clear whether providing this specific question beforehand lead parents thoughts down the path of considering specific sports in their decision-making process and hence reporting opinions on each.

Finally, the above considerations are mostly of head impacts in contact sports. All listed contact sports have been identified to have a concussion risk in the literature and feature that concussion can be caused by knocks to the body independently of the head. If parents are considering concussion solely as a knock to the head, they may be lowering or increasing their risk perceptions of sports where concussion could be caused through other means (body tackling, falls). The same could apply where parents perceive injuries to be caused only by other players;

“I felt these have the least contact with other people directly and the least aggressive sport.”

“I think horse riding is less of a sport which people get hurt in.”

This suggests parents are not taking in to account other causes of impact such as falling from a horse or being hit with a cricket ball. This was not the case in all responses however;

“Whether it used equipment that can hurt you.”

“How much of a contact physically with other people or equipment chose safest option.”

(q) Risk Factors

Parents frequently mentioned risk factors and predisposition broadly and through gender and genetics;

“If my child could be predisposed to dementia following concussions I would seriously consider think[ing] about stopping them from playing serious contact sports.”

“I would not let them play contact sports if they had a genetic link.”

“If my child is more susceptible then I would not allow them to play any sports.”

“If it was a massive risk factor I suspect my answers may be different.”

“Due to my daughters being female.”

Parents are likely to have been influenced by the preceding questions highlighting genetic and gender risk as factors. In some cases however, parents did not consider gender to be as an important deciding factor, comparing it to genetic risk;

“Genetics implies this would cause problems with less impacts and also is more specific to an individual than gender.”

“The risk of gender is not big enough a reason while a genetic test is.”

Whilst gender and genetics were separated for this survey, potentially raising the distinction in parent’s minds, they were included separately to assess how parents perceive them as consideration factors. It was explicitly pointed out throughout the survey that gender referred to biological sex, a factor that is genetic. With some parents deeming gender not important or less so than genetics, it suggest a lack of understanding of genetic risk or a potential attempt to treat their children in a ‘politically correct’ equal manner despite gender. However, this could instead be interpreted, in line with previously discussed genetic fatalism (Heine et al., 2017), that parents perceive a more specific genetic risk factor for one specific outcome as more deterministic.

Conclusion

This thematic analysis led to a greater understanding of the specific themes parents may consider when weighing up contact sport participation risks and benefits. Of note were the key role of feelings of control – the deterministic attitudes some parents presented toward genetic risk – and the perceived risk of certain sports in comparison to actual risk (Quarrie et al., 2017). Qualitative research is often used when aiming to identify routes for ‘real-world’ impact or designing and assessing clinical applications (Kearney, 2001). It has been described as tackling the ‘how’ rather than ‘how many’ questions, and looking at concepts and processes from the point of view of the informants studied (Pratt, 2009). Quantitative research on concussion knowledge and attitudes found a poor link between understanding of safety and actual intended behaviours (J. Williams et al., 2016). Mixed-methods approaches may allow for greater understanding of the individuals and how best to support them. This qualitative approach can be used at different stages in a research project to generate hypotheses, develop interventions, guide sampling, pursue results in depth, provide interpretations of unexpected results, generalize results to different populations, or explain outliers (Morgan, 1998).

The inclusion of this qualitative thematic analysis method in the current study aids in the identification of relevant contributory factors that may have been missed by the closed questions and quantitative analysis (Madill & Gough, 2008). This is particularly true as the open-ended question relates to quantitative questions analysed in Part 1, rather than as a standalone section. Findings in Part 1 address parent decisions regarding which contact sports they would allow their child to play, and whether these would shift based on genetic-risk. Alone this data suggested some significant predictors of decisions and how these environment risk assessments changed based on biological risk. However, for feasibility and to reduce overlapping variables, the number of influencing factors was limited based on previous surveys, with slight alterations filling current gaps in the literature. Many potential predictors were not included, and a simple tick-box exercise does not provide a deep understanding of the decision-making process taking place. This thematic analysis, for example, raised the importance of parent’s feelings of control, something not measured and included in the regression models. As such, this qualitative work may inform future survey design,

and may have instead been more suitable as part of the piloting process before this study. This is one identified use of qualitative method (Morgan, 1998), and something missed in the current study which only piloted the quantitative elements with later inclusion of a qualitative element for added depth. This is important as qualitative approaches should not just be considered as a preparation for quantitative work and have importance alongside them. For example, the 'control' factor highlighted above could be difficult to measure outside of a qualitative context, as current assessments of 'sense of agency/control' typically rely on movement-based visual or physical tasks which may not reflect the complex beliefs expressed in this survey (Dong, Sandberg, Bibby, Pedersen, & Overgaard, 2015).

Further analysis of parent knowledge sources and awareness of information or aid-services in relation to concussion, dementia, and genetic risk (e.g. counselling, screening, heritability) is carried out in the following section – aiming to elucidate where these misconceptions and fatalist attitudes may derive from, and again ultimately support the production or dissemination of educational material.

Part 3: Sources of Information, and Awareness of Relevant Services

Results

Sources

Three hundred and eleven participant responses to a multiple-tick list of 14 responses were tallied, with further individual information in response to 'Other' (sources of information) noted. The source with the highest number of selections was Television, followed by Friends or Family, and then Newspapers. The least frequent source was Internet Blog, followed by Sports Coach, and Pamphlet (see Figure 5-4). Other responses fell mostly in to eight overall data-derived categories: Personal Experience, Medical Training, General Knowledge, Research, Occupation, School, Medical Professional, and Miscellaneous (see 5-5)

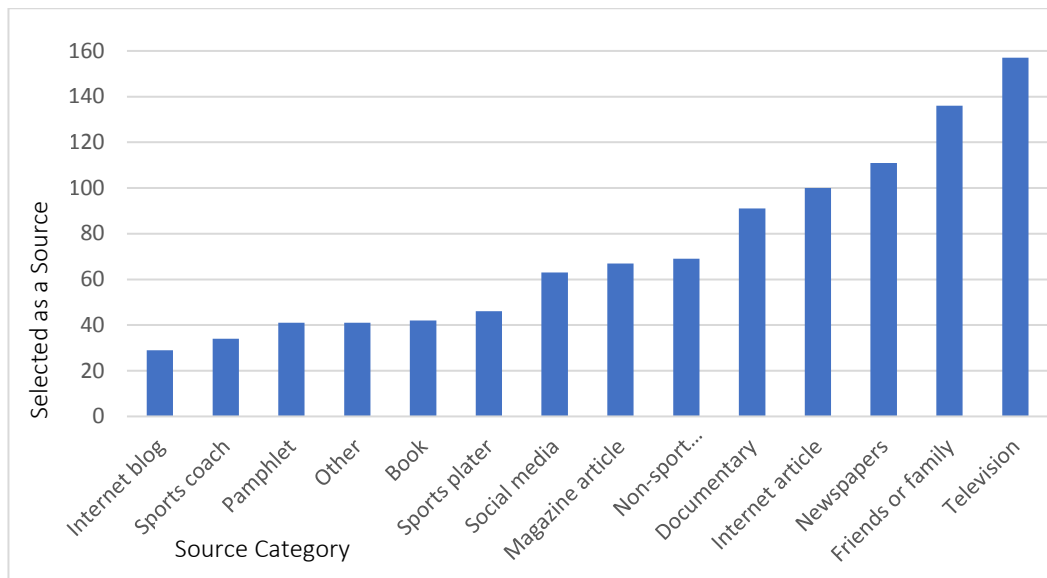

Figure 5-4. Sources of information on concussion in parents. Bars represent total number of times each category was selected.

Personal Experience	<ul style="list-style-type: none"> - Life - Experience - From own experience - Just knowledge from life - Associate with brain injury - Own experience - A child in my son's school - Personal experience - My daughter has cerebral palsy resulting from a brain injury
Medical Training	<ul style="list-style-type: none"> - I got a pharmacist degree and we learned about concussions, about their consequences and how to recognize potential symptoms. - A first aid course/training x 6 - Armed forces medically trained - Medical school
General knowledge	<ul style="list-style-type: none"> - General knowledge x 3 - Never learnt anything in particular about concussion, it is all based on my own assumptions - Just information gained over my life, with some assumptions made. - Common sense x 2
Research	<ul style="list-style-type: none"> - Research - Read some studies/ papers
Occupation	<ul style="list-style-type: none"> - Workplace - Through my job on hospital ward patients who have had falls - I work in a hospital

	<ul style="list-style-type: none"> - I am nurse trained (no longer practicing) do had a little knowledge from that - From Nursing Experience
School	<ul style="list-style-type: none"> - School phys(ical) ed(ucation) teachers - I think from school - School
Medical professional	<ul style="list-style-type: none"> - Doctors - Hospital
Misc:	<ul style="list-style-type: none"> - Radio 4 had a doctor on the Today programme talking about brain injury and rugby. - Watching medical dramas - Word of mouth - I haven't had any need to look it up

Table 5-5. Table categorising participant responses to 'other' as an information source option. Direct quotes with exact overlaps removed.

Services

The total number of participant responses was summed up for each of the questions relating to: Dementia, Concussion, and Genetics. Responses were categorised as Yes (including specific answers) or No. Named services were then divided into data-derived sub-categories per question and in some cases were multiple per participant.

Of 301 participant responses, 33.2% answered that they weren't aware of any dementia services, 66.7% replied either Yes (22.3%) or with details of particular service/s. Of 300 participant responses, 42.3% reported that they didn't have knowledge of any concussion services, and 57.7% replied either Yes (17.3%) or with details of particular service/s. Of 298 participant responses, 58.1% reported that they were not aware of any genetic risk services, 41.9% replied either Yes (17.4%) or with details of particular service/s. (see Figure 5-6)

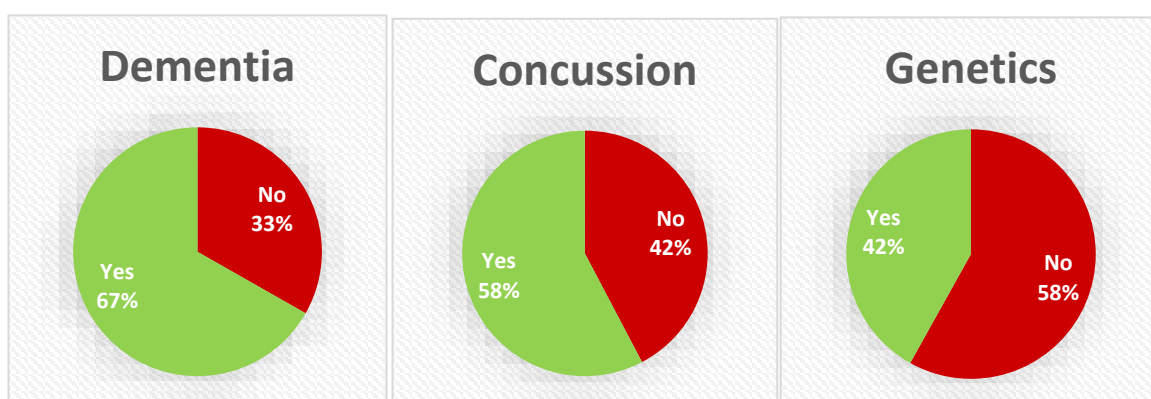

Figure 5-6. Awareness of relevant services for Dementia, Concussion, and Genetics (eg. counselling, screening). Total percentage of Yes (including named services) and No (Don't Know) responses.

Dementia

When asked if parents were aware of any services for concerns or questions regarding Dementia, NHS services were mentioned 89 times. This included NHS hospitals, NHS direct, NHS websites, and NHS phone lines as well as general practitioner services (n = 15). There were six website references with specific mention of www.reddit.com (general forum), www.patient.info (medical information) and www.google.co.uk

(search engine). In addition, there was a single mention of a pamphlet (source not named) and 2 local groups; local dementia groups and a local village group. There were 43 references to specific charities including: Age Concern UK, Dementia UK, Alzheimer Society, Age UK, Dementia Foundation, Relate, Alzheimers.org, Dementia Society, Mind, and Alzheimer's Association. Lastly, there were individual mentions of the Canadian Government funded Alberta Health, and the United States national CDC (Centers for Disease Control and Prevention).

Concussion

When asked if parents were aware of any services for concerns or questions regarding Concussion, NHS services were mentioned 109 times. This included NHS hospitals, A&E NHS direct, NHS websites, NHS phone lines, and general practitioner services (n = 18). There were 8 references to charities (named: Dementia Foundation, Dementia UK, Relate, Brain Charity Trust, Mind), and 7 Website mentions including www.patient.info (medical information), www.google.com (search engine) and www.reddit.com (general forum). There were also individual (n = 1) mentions of; Pamphlet, Sports Association, Local Group, Pharmacy, and Public.

Genetic Risk/Testing/Screening

When asked if parents were aware of any services for concerns or questions regarding Genetic risk/testing/screening, NHS services were mentioned 50 times. This included NHS hospitals/local clinics, NHS direct, NHS websites, UKGTN (Genetic testing service related to the NHS), and general practitioner services (n = 14). Notably, there were 20 references to websites including the named www.ancestry.co.uk (genetic testing/family history), www.reddit.com (general forum), www.23andme.com (genetic testing/family history). Lastly there were 3 mentions of private medical services (named: BUPA), 2 private companies, and 1 charity (Dementia Foundation).

Discussion

This survey of parents aimed to investigate the most common sources of information on concussion, mild brain injuries, genetic screening and dementia. Awareness of services for the same potential concerns was also assessed through open-ended

questioning. A key aim of social-cognitive based psychological approaches to health concerns is the development of programmes or services that could both increase awareness and improve attitudes/change beliefs, something typically done by utilising a multi-factor model of attitude formation such as TRA/TPB (Ajzen, 1991;Ajzen, Joyce, Sheikh, & Cote, 2011). As such, this study sought to highlight potential new avenues for information dissemination and identify those services in need of greater promotion to the public.

Major sources of parental knowledge of concussion were television, friends and family, and newspapers, with less frequent mention of internet blogs, sports coach and pamphlets. Internet blogs are arguable accessed media in general, however the limited influence of sports coaches and pamphlets suggest that parents have either limited awareness of concussion safety initiatives in their child's sports groups or schools, or that these do not exist. Whether this lack of awareness reflects an actual lack of policy and safety management is unknown.

The categories could be further refined due to potential overlaps such as Television and Documentaries. Whilst the findings suggest that not all information from television is in the form of documentaries (e.g. the Alan Shearer documentary "Dementia, Football and Me"), respondents did not explicitly identify the alternative show formats. It would be of interest to ask parents if their knowledge was acquired through other types of programming such as live sports broadcasts, chat shows, news programmes or even fictional programs in which concussion featured (e.g. the recent Will Smith film "Concussion").

Parent responses from those who chose to provide an 'other' alternative information source mostly fell in to the categories of medical training, occupation, general knowledge, and personal experience. It is not possible to deduce if this is an accurate reporting of where parents' actual information on concussion comes from, nor does it identify if there are subtler indirect or implicit information sources influencing knowledge and attitudes. Future work should aim to include survey/interview measures in combination with implicit attitude approaches, especially as these appear to be particularly sensitive to affective (emotional) material in attitude/belief formation (Rudman, 2014). Such effects would be difficult to accurately identify but would be important considering the TRA/TPB model of multiple levels of influence, and

the potential for 'under the radar' influence of social norms experienced through peers or presented in media.

Overall assessment of parental awareness of potentially relevant services (that they could access for support and information) found differences between each of the concern elements. Parents answered yes or provided details of specific named services most frequently in response to dementia. Particular services named were the NHS, charities, or the internet. There was a similar level of awareness for concussion related source of information, with 42% answering no. However, the named services were again primarily provided by the NHS, charities, and the internet. Awareness of genetic-risk information sources was unsurprisingly the lowest, with 58% of parents reported not being aware of any such services. The profile of common named services also differed for genetic information relative to dementia and concussion sources, highlighting increased public interest in direct-to-consumer sources of information (such as 23andme.com), and the broader role played by genetics beyond health/illness (e.g. genealogy, identity). This suggests that these platforms may be useful to target to provide relevant information to the public.

Participants who did not answer the question were obviously excluded from the analysis, however it is possible their lack of answer may reflect lack of knowledge. Thus, the current findings may reflect an over-estimation of parent awareness.

In summary, these results support the use of multiple forms of information sources but suggest communication or impact initiatives take advantage of television, newspapers, and the internet. Passing on safety and risk details in a digestible manner should also allow for dissemination through friends and family. With low levels of service awareness, particularly for genetic related concerns, it is important to consider details on services available locally or nationally as a piece of safety related information to distribute through the above methods.

Concluding Remarks

This three-part study adds to our understanding of parental attitudes towards, and knowledge of, concussion risks in contact sports including football and rugby. These sports were focused on in particular due to both their high participation rates in the UK (Sport England, 2016), and prominence in sports related concussion research and the

media (Brisbourne, 2017; Shearer, 2017). This study utilised previously developed assessments of concussion attitudes and knowledge, in addition to multiple replicated and novel measures of influential factors. It was able to amalgamate these multiple elements, with the addition of richer qualitative information on participant thought processes, to develop a more detailed picture of concussion, contact sports, dementia, and genetic risk perception in parents.

This is an area with little and typically variable assessment, but which frequently highlights the need for services or policies to improve knowledge and awareness. The above and the reported sources of information and key services may be utilised aiding in developing effective targeted information and safety initiatives suitable for a range of sports and different demographics. The findings from this study further contribute in the potential development of future awareness and safety initiatives, finding that television, family and friends, and newspapers were major sources of concussion information. Recent research highlights exaggeration by the media in public misunderstanding of health issues (Adams et al., 2017), and so it will be important to conduct further research on media reporting of concussion risks. A recent systematic review of online articles relating to sports concussion in hockey, football, soccer, and rugby, found high variability in reporting, most often due to journalist misrepresentations of the risks. A 'Media Concussion Checklist' was ultimately developed from the data, advising through six key points how the public can have a better understanding of sports concussion, aiming to improve general public knowledge and safety through greater awareness in both prevention and management (Osman Hassan Ahmed & Hall, 2016).

My research highlights the need for such work, finding surprisingly low levels of concussion knowledge compared, together with generally rather lax attitudes towards safety, with some parents reporting no knowledge of appropriate services. Such services could tailor future initiatives based on factors predictive of concussion knowledge identified in this current study. Gender, childhood mTBI, medical literacy, and concussion attitudes may play a role. Information should be made accessible in order to reduce limiting effects of low medical literacy, and any behaviour moderating approaches should aim to tackle both attitudes and knowledge together for greater effectiveness. Future research investigating sources in detail would allow for further

and more effective development of knowledge transfer. For example, within television (as the mostly cited information source in this study), would a more 'credible' documentary featuring prominent sport personalities and medical professionals increase positive attitudes and knowledge or would a narrative fiction (films such as *Concussion* featuring Will Smith) be more effective? The processing of information in decision-making is likely a combination of cognitive and emotional factors and, if so, further work is necessary to determine what contribution affective influences have on behaviours that could change cognitive health over the life-span.

Of note, in the above study, was the topic of misperception. Parents presented with misperception of concussion, actual sport risk, and genetic science. Some parents reported overall poor knowledge of concussion, despite safe attitudes. Rugby was perceived as riskier than football, despite this not being reflected in the literature (Quarrie et al., 2017). Finally, thematic analysis revealed that, despite parents often choosing not to let their child/ren play if they were at a genetic risk of poor outcome, there is poor understanding of the role genetics play in a multi-factor model of life-course cognitive health. This relates back to the TPB in which perceived control is involved in attitude formation and subsequent behaviour (Ajzen, 1991), and would benefit from further study to assess parents' knowledge and experience with genetic risk and what other factors they may believe are out of their control or knowledge base. As one participant described "If it was a massive risk factor I suspect my answers may be different."

Importantly, this research needs to be considered in the context of health research in general. It is not known how specific these results are to concussion and cognitive health. It is possible they represent attitudes and knowledge of other health issues such as chronic diseases or injuries. However, it is also possible they represent awareness and thought-processes specific to concussion. This would be of particular interest due to the high level of media released in relation to this particular health issue (Carson, 2017). Findings from this survey may be unique or comparable to other highly publicised concerns such as cancer or HIV (Hether, Huang, Beck, Murphy, & Valente, 2008). In other health areas, research has also found poor awareness of genetic risk and use of genetic counselling services in GPs (Aalfs, Smets, de Haes, & Leschot, 2003), a wide variety in sources of diabetes information (Schoenberg, Amey,

& Coward, 1998) and typically poor knowledge of it associated with television (Zhao, 2014), an increased awareness of depression based on gender, age, and personal experience (Hight, Hickie, & Davenport, 2002), and the mental construction of models of disease fatalism by those who have a family history of chronic illnesses such as cancer and coronary artery disease (Walter, Emery, Braithwaite, & Marteau, 2004). There is evidently some overlap with these findings and those on concussion, genetics, and dementia within this research. This could be demonstrated through parental considerations of the benefits of sport, both in the closed-questions and thematic analysis, where physical and mental health was considered. The sport participation was often not considered as just a concussion risk, but a general health benefit.

To some extent this survey was able to expand on this weakness in the current literature by including a general injury scale. Results showed a lower concern for other injuries influenced how likely parents were to allow their child to play rugby. Future research would benefit from investigating this further through comparison with regressions regarding other health concerns, as this suggests a more general health-decision approach was tapped in to. This is an aspect that the qualitative thematic analysis approach used here could be highly appropriate for. Allowing participants to express their health decisions more generally could reveal if there are any differences in which deciding factors impact which types of concern, and if they receive difference weightings. This would take advantage of this more 'in-depth' method, improve interpretation of quantitative survey results, and allow for more effective targeted interventions.

6. General Discussion

People are living longer. It has been predicted that by the year 2050, the world's elderly population will more than double its current number, reaching 2 billion (United Nations Department of Economic and Social Affairs Population Division, 2015). As a consequence of rapid population aging, there is a rising incidence of age-related neurocognitive disorders. In order to reduce the global burden of disease attributable to such disorders, a key focus must be on identifying ways to optimize life-long neuronal enrichment, maximise neuroplasticity and ensure the highest possible maintenance of cognitive function over the adult life course (Anstey, 2014). It is increasingly recognised that lifelong patterns of behaviours, endogenous factors (including genetics) and exposure to environmental factors earlier in the lifespan set the stage for cognitive outcomes in late life (Jagust, 2016). The STAC-r model of cognition and aging (Reuter-Lorenz & Park, 2014) incorporates life-course factors that serve to enhance or deplete neural resources, thereby influencing the developmental course of brain structure (and function), as well as cognition, over time (see Figure 6-1)

A Life Course Model of The Scaffolding Theory of Aging and Cognition (STAC-R)

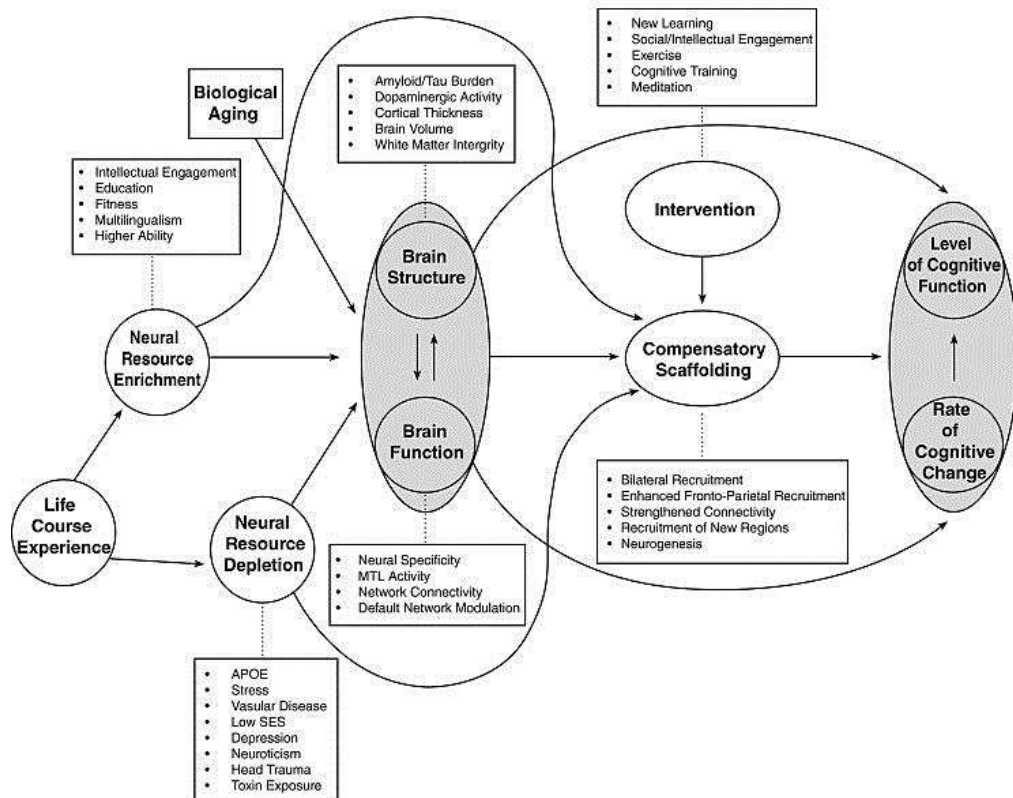

Figure 6-1. Conceptual STAC-R model from Reuter-Lorenz & Park, 2014, p.360

My work focused on genetics and physical activity, with genetics (specifically genetic variation in *BDNF*) representing one such endogenous factor, physical activity as a modifiable behavioural factor, and sports concussion as an environmental factor relevant to later life neural and cognitive health. However, it is of course unlikely that participation in physical activity and genetic predisposition are independent factors (i.e. there will be gene-environment interactions and gene-environment correlations) (Rutter, 2006) and future research would benefit from investigating how genetics could influence an individual's participation in and outcomes from physical activity, with consideration of other genetically influenced individual differences such as the personality traits of sensation seeking and conscientiousness (Reiss, Eccles, & Nielsen, 2014).

As outlined in the general introduction, health neuroscience conceptualises brain-health relationships as being subject not only to the modifying influences of genetics, lifestyle and other individual-level factors, but also as subject to the contextually modifying influences of social and cultural factors, that operate outside the individual (Erickson et al., 2014). The second part of this thesis adopted a mixed-methods approach to gain novel insights on the factors that influence parents' knowledge of and attitudes towards their child's participation in sport, in relation to the risk of concussion and mild traumatic brain injury. Increasing importance is being given to mixed (quantitative and qualitative) methods research across the health sciences. The major advantage of using mixed methods, as illustrated by my own findings, is that quantitative data can yield generalisable results and qualitative data can provide extensive and in-depth insights (Zhang & Watanabe-Galloway, 2014).

[Summary of findings, implications, limitations, and directions for future study](#)

Part 1. Genetics and Physical Activity

From a lifespan perspective on cognitive health, a number of studies converge on the importance of the medial temporal lobe (MTL) areas, particularly the hippocampus. The MTL appears notably plastic and susceptible to intervention effects across ages, presumably related to its role in supporting key learning and memory functions (Walhovd et al., 2016). However, it has also been suggested that regions characterized

by a high degree of life-long plasticity are vulnerable to degeneration in aging (Fjell et al., 2014; Mesulam, 1999). Hence, the focus on my neuroimaging studies was MTL structure.

The genetic component of my work focused on the potential neurostructural effects of genetically-determined individual differences in BDNF, a protein with a demonstrable influence on neurogenesis, neuroplasticity, recovery from trauma and neurodegenerative protection (Voss et al., 2013; Dooley, Ganz, Cole, Crespi, & Bower, 2016). The *BDNF* Val66Met polymorphism was chosen due to its impact on the secretion of BDNF (Egan et al., 2003; Lang, Hellweg, Sander, & Gallinat, 2009) and because recent research reveals the *BDNF* Val66Met polymorphism may play an important role in cognitive decline (Boots et al., 2017). It had been suggested that there may be lifelong neuronal deficiencies associated with the Met allele, particularly reduced MTL volumes and cortical thickness (see Chapter 2 for references). A recent meta-analysis revealed some support for this suggestion (Harrisberger et al., 2014), although the picture is mixed, with several null and even opposite findings. My work adds to the currently conflicted literature on the influences of the val66met polymorphism on brain structure. I found no effect of the Val66met polymorphism on hippocampal or amygdala volume but did find a link between the met “risk” allele and *increased* parahippocampal thickness, which was suggested to perhaps reflect neural inefficiency. One limitation of that chapter was the lack of task-related functional imaging, which could potentially have addressed this issue (Poldrack, 2015). Future work should also examine whether *BDNF* genotype influences brain structure at different points along the lifespan, to allow for a greater understanding of to what extent certain influencing factors can alter life-span cognition, and if any are particularly beneficial or limiting at certain ages (Reuter-Lorenz & Park, 2014). This would extend my current work, as projects with older participants in greater numbers, could aid in the confirming of, and identification of, other genetic-neurostructural-cognition links that were not found in my *BDNF* (or physical activity work) with mostly healthy young adults.

The large sample size did however permit a novel structural covariance analysis (Alexander-Bloch et al., 2013). Findings suggested a left lateralised effect of val66met on hippocampal and amygdala structural covariance, which I argued might result from

stress-related neuroplasticity. Thus, future work on the Val66met polymorphism would benefit from focusing on not just the hippocampus as a vulnerable structure and proposed hub of memory processing, but on functional and structural links with the amygdala and assessment of relevant cognitive emotional processes such as fear learning and stress.

Without taking BDNF serum measures from participants, it is not possible to determine if links found between genotype and brain structure are related to different levels of BDNF protein. Research by Minelli et al. (2011) for example, found links between BDNF serum levels (but not Val66met) and fear-related personality traits such as harm avoidance. Other work has however supported links between the presence of a Met allele and higher BDNF concentration (Lang et al., 2009), and found Val66met to act as a moderator of correlations between BDNF levels and cognitive function (Jiao et al., 2016). Nevertheless, even including BDNF biomarkers would not enable us to establish causal relationships. Additional studies relating structural MRI findings to underlying neurobiological changes in animal *BDNF* genetic knock-in and knock-out models (Notaras, Hill, & van den Buuse, 2015), will facilitate further understanding of the causal role of *BDNF* genetic variation in underpinning individual differences in brain structure.

The current work was limited to the study of one gene due to the nature of the data set. As part of an ongoing large multi-study project, limitations were placed on data available for individual projects to allow for fair segmentation among research groups and to limit repetition in statistical analyses. Whilst the gene was chosen based on its prominence within the current literature, and the use of this secondary data set allowed for a large number of participants, suitable for structural covariance analysis, future work would benefit from the assessment of additional genes – especially in the context of a life-span multi-factor model. Research has suggested interaction effects between BDNF and Catechol-O-methyltransferase (COMT) genes on cognition (working memory) and functional neuroimaging results (resting-state MRI) (Chen et al., 2016). A large study in older adults (50-79) found episodic memory functioning was predicted by an interaction between Val66Met and *APOE* genotype (Ward et al., 2014). Only in *BDNF* Met carriers did the positive or negative effects on cognitive functioning of *APOE* polymorphism present. Notably, such life-span approaches face considerable

challenges, since it would ideally be conducted in large representative samples studied longitudinally. The challenges typically facing studies tackling ‘population neuroscience’ (the integration of epidemiology, genetics, and neuroscience to identify life-span influences on brain health) may be partially mitigated in future research by forming large-scale consortia (Lerch et al., 2017), although such studies will need to overcome the challenge of integrating data across multiple sites and scanners (Lerch et al., 2017). With only one gene investigated in my current work, there was a lack of control over potential confounding effects of other related genes. However, my research benefited from a homogeneous population and the use of the same scanner and analysis pipeline throughout. To increase power to detect genetic associations, future research outside of a time and finance limited PhD context would benefit from the use of genome-wide polygenic scores – summaries of multiple risk polymorphisms identified from genome-wide association studies (GWAS) (Pasaniuc & Price, 2017). Such work can be expensive, and analysis would have to weigh up the level of correction needed for the multiple genetic analyses. Future research taking this broader approach would also need to consider interaction with many other cognition/neural-structure influencing factors that were not available for analysis in the current project; environmental adaptation and cognitive strategies (Goh & Park, 2009), demographic differences (Kim et al., 2013), and early life stress (Gatt et al., 2009).

While increased structural covariance might arise from increased structural connectivity between brain regions (Alexander-Bloch et al., 2013; Evans, 2013), other techniques may be better placed to study the impact of *BDNF* on hippocampal connectivity. Functional connectivity MRI may allow for better identification of abnormalities or differences in how brain regions work together, especially relevant when considering compensatory scaffolding in later life (Reuter-Lorenz & Park, 2014), and can establish directionality of connectivity (Alexander-Bloch et al., 2013). Alternative structural imaging techniques such as diffusion MRI (dMRI), which measures the directional diffusion of water in the brain (Gardner et al., 2012), could also aid in the further identification functional brain networks and has been used, for example, to identify structural changes in elderly adults following a one year fitness programme (Thomas et al., 2012). As with the above genetics, there was limited access

to neuroimaging data available due to the large amount of data and set analysis pipelines. Diffusion data in the same participants was sought to follow-up on the current structural findings (volume, thickness, covariance) but was unavailable within the PhD timeline. However, structural covariance does potentially provide insight in to correlations between anatomically distributed regions or reflect function beyond white matter (Alexander-Bloch et al., 2013). Future research would benefit from follow-up of amygdala and hippocampus associations with multiple neuroimaging methods, consideration of the wider genome, and further measures of individual differences. This is reinforced by findings linking early-life stress and trauma with functional-connectivity between the amygdala and hippocampus (Fan et al., 2015; Hermans et al., 2016),

While the causal role of exercise in modifying hippocampal neuroplasticity has been well documented in animal models (Voss et al., 2013), it remains unclear in humans whether physical activity boosts brain function by inducing structural changes in the hippocampus and related medial temporal lobe circuitry; brain areas that are important for learning and memory. This is partly because the association between physical activity and hippocampal volume during early adulthood has not been effectively explored. In this work I considered the role of physical activity, through assessment of self-reported participation in both moderate-intensity and vigorous-intensity activities throughout an average week.

My findings in Chapter 2 did not replicate previous work suggesting links between physical activity and MTL structure (Killgore et al., 2013; Pajonk et al., 2010). A limitation of this study was the relative modest sample size and high-functioning University student sample. Future work could examine a larger, more representative sample. However, such a study recently conducted with over 800 participants of varying age and mixed gender, found no link between physical activity and MTL volume, suggesting previous findings were possible false positives (Jochem et al., 2017). Instead it would be beneficial for future work to focus on, for example, exercise interventions, multi-modal neuroimaging, and objective sensitive cognitive testing (eg. Thomas et al., 2016), although it should be noted that physical activity involves both exercise and non-exercise activity. Longitudinal work would also allow for further detail on whether physical activity in younger adults could build capacity for

compensatory scaffolding later in life or influence fitness related behaviour throughout the life-course. In addition, self-report activity is subjective to a number of biases, so other objective measures of activity (e.g. actigraphy) should be employed. Perhaps most urgent is the requirement to develop a theoretical model describing the interactions between physical activity, brain structure and cognition, in order to inform effective interventions across the lifespan.

An unexpected but notable finding in relation to a multi-factor life-course model of cognitive health was my finding of a link between higher levels of vigorous exercise and lower semantic memory scores, despite most research focusing on spatial and episodic memory in relation to physical activity (Voss et al., 2013). Whilst the mechanism behind this is unclear, and further study is needed, it could be a demonstration of an activity 'trade off'. I.e. individuals participating in more exercise may be using their leisure time in different ways to other participants. Such potential trade-offs would be relevant to the design of potential public health interventions. This highlights limitations in my current study, which may miss potentially related confounding factors. As part of a larger multi-study project, participants went under multiple neuroimaging and neuropsychology assessment sessions. As such, the amount of measures that I could include was limited by financial and fatigue considerations. There is potential for influences unmeasured that could be related to physical activity. Links have been made between socio-economic status and fitness (Jiménez-Pavón et al., 2010), and diet and sport participation (Nicole, Jessica, Mary, & Dianne, 2014). With a reduction of cognitive abilities with age related to physical activity, education level, social support, diet, stress, and environmental toxins and traumas (Van der Linden & Juillerat Van der Linden, 2016). Future work would benefit from including assessments of the individual's SES and other health related behaviours and environmental support. Other potential benefits of physical activity and sport participation should also be considered and assessed – an individual's social network, for example, has been linked to differences in brain structure (Kanai, Bahrami, Roylance, & Rees, 2012). Inclusion of extra neuropsychological assessments would also be appropriate if future work were to use the same young healthy sample group, with an aim to identify subtle underlying differences that could subsequently impact on neural resources over the lifespan (Reuter-Lorenz and Park, 2014). This is important as

only limited number of studies have investigated the relationship between physical activity and brain volumes at younger ages (e.g. Killgore et al., 2013), and links between mid-life fitness and neurodegeneration (Carlson et al., 2008) highlight how a young individuals participation in physical activity could influence their later engagement with fitness – important as part of a life-span approach. Inhibition and executive functioning assessments utilising STOP-GO or saccade control paradigms may be most suitable for this, and have been used in young adult research (Cheung, Mitsis, & Halperin, 2004), children as they age (Jonkman, 2006), and concussion samples (Alex et al., 2007).

These findings are of importance when considering the aim of the second part of my thesis was to inform knowledge transfer and potential intervention initiatives. These results suggest that physical activity at a younger age is unlikely to halt cognitive decline with age alone, and the associated benefits (e.g. socialisation/diet), may be part of a larger interacting model. Physical activity should be considered as one contributory influence alongside others, and individuals are most likely to benefit cognitively from small gains across multiple influencing factors.

Overall, the current research also suggests refinement of the STAC-R model, which incorporates multiple biological and environmental influences (both negative and positive) (Reuter-Lorenz & Park, 2014). Whilst bi-directionality was included in the model, there are other factors that may need to incorporate this interacting perspective. For example, the neural resource enrichment category (see Figure 6-1) includes fitness (rather than physical activity per se), whilst the neural resource depletion category includes *APOE* as the sole representation of genetic influences, and head trauma including concussion. More complicated relationships may exist. Val66Met (*BDNF*) genotype may have an influence on neural structure dependent on fitness level (Herting et al., 2016) but is also linked to riskier behaviour (Choi et al., 2016) – potentially leading to increased risk of head injury. Literature also points to an association between social isolation and dementia (Kuiper et al., 2015), which could bidirectionally influence the rate of cognitive change overall. The STAC-R model currently only considers the influence of rate of cognitive change on level of cognitive functioning. These concerns reinforce the development of the emerging field of health neuroscience which sees the brain as both the target and mediator of health

behaviour, cognition, stress, and genetic influence, in addition to consideration of contextual influences such as social, cultural and health policy details (Erickson et al., 2014).

Part 2: Attitudes and Knowledge

Part two of my work looked at how health neuroscience research into factors affecting cognitive health across the life-span could interface with health psychology work looking at links between attitudes-behaviours and both knowledge and its communication to the general public. Physical activity's role as an intervention for both compensatory scaffolding and long-term cognitive health (Reuter-Lorenz & Park, 2014) was considered a factor of importance due to a noticeable recent increase in interest around potentially negative long-term cognitive effects of mild traumatic brain injury, or sports related concussion (Doolan et al., 2012; Marshall, Bayley, McCullagh, Velikonja, & Berrigan, 2012; McKee et al., 2013). It has been suggested that misperception of actual contact sports risk (Quarrie et al., 2017) and misrepresentation of concussion in the media could potentially lead to inappropriate responses in parents such as withdrawing their child from sports completely (Kerr et al., 2014), limiting any potential benefit of exercise on neural and cognitive health. Indeed, in the US Youth football has seen a steep decline in participation in recent years, with concern over concussion credited as the leading cause of the decline in participation (Findler, 2015).

According to the theory of planned behaviour (TPB) (Ajzen, 1991), behaviours are a direct product of three antecedents: attitudes (beliefs about the behaviour's likely consequences), subjective norms (the expectations of important others such as family, friends, the media), and perceived behavioural control (beliefs about the presence of factors that control behavioural performance). As applied to my research, the TPB posits that parents' intentions to allow child participation in contact sports are caused by their attitudes toward sport participation and its potential benefits and risks (concussion), their subjective social norms (e.g. that playing despite potential concussions is a sign of "toughness"), and their perceived behavioural control over whether a concussion (and potential long term negative outcomes related to e.g. genetic factors) can in fact be avoided (Williams et al., 2016).

My narrative review found that attitudes could potentially influence behaviour related to concussion through three key routes; prevention, management, and the manifestation of symptomology. Importantly, it demonstrated how attitude formation takes place within a broader model including knowledge, social norms and peer influence, as predicted by the TPB (Ajzen, 2011). As the review also evidenced how safety related behaviour is better predicted by specific attitude-behaviour related self-report, and that in general, concussion attitudes and knowledge were poor in the public and athlete populations, a new survey was developed for this thesis. It aimed to determine predictors of whether parents would allow their children to participate in contact sports, focusing on football (soccer) and rugby in particular. Multiple factors were found to influence a parent's decision, including general risk attitudes, general injury concerns, degree of medical literacy, sport benefits perception, and consideration of genetic or biological gender-related risk, with interesting differences emerging between football and rugby. Medical literacy, general risk attitudes, concussion safety attitudes, and experience of their child having mTBI were linked to concussion knowledge. These could potentially reflect unmeasured confounds such as socioeconomic status, or even a pervasive effect of sensation seeking tendencies.

To investigate parental decision-making process in richer detail, I supplemented quantitative analyses with an exhaustive qualitative analysis, based on thematic analysis (Braun & Clarke, 1986) of participant responses to an open-ended question. Of particular note, this qualitative analysis revealed that parents' considerations were tied heavily to feelings of control, a key feature of the TPB (Ajzen, 2011), and often involved misperceptions of the injury risk in certain sports (Quarrie et al., 2017). Expressions of genetic fatalism were frequently present, indicating how a misunderstanding of genetic risk could result in individuals failing to address other influences in a multi-factor model that could be beneficial for cognitive health. In relation to this, my final analyses looked at parent's sources of information and awareness of services available for help with concussion, dementia, or genetic concerns (risk, counselling, heritability). How these results, highlighting television as a main source of information and overall poor service awareness, could influence the development of knowledge transfer and safety initiatives is discussed below.

The attitude and knowledge survey included in the second part of my thesis was comprised of validated measures and common topics of interest from previous work, in addition to extended questions on sport participation and genetic/biological gender factors. However, the concussion attitude assessment was kept relatively brief to reduce potential fatigue effects. The survey was generally on the same topic, included questions in which parents were asked to select from the same list multiple times (sport choices), was conducted online without supervision, and included a potentially more time consuming open-ended question for detailed thematic analysis. Future work would benefit from including multiple measures of attitudes and beliefs (e.g. including the whole RoCK-AS), and the inclusion of parents, children and coaches together to investigate to what extent children are influenced by parents, coaches and peers (Williams et al., 2016). Of key interest, evident from the thematic analysis, was the element of perceived control in decision-making. Whilst this is identified in theories modelling attitude influences, such as the theory of planned behaviour (Ajzen, 2011), and its role across a multi-factor model of cognitive health is supported by work on genetic fatalism (Dar-Nimrod & Heine, 2011), it was not included as a measured factor within the quantitative aspects of the survey. Development of this survey further could aim to look at individual differences in feelings of control in general, and beliefs about the role of genetics, in addition to more in depth options on sources of information, allowing for improved application in communication initiatives. This highlights how qualitative methods have multiple roles in projects (Morgan, 1998). Whilst this questionnaire was based on previous literature and validated quantitative assessments, the thematic analysis was added without prior testing. Pilot work with the open-ended question or a variety could have suggested the inclusion of an assessment of control or control-related beliefs as discussed. However, in the context of the current PhD it provides more depth on the mental reasoning behind the quantitative aspects of the survey, supports the use of a mixed-methods approach, and identifies how future work can develop on this to cover a greater range of impacting factors for greater 'real-world' intervention success.

A notable strength of the survey work was that it incorporated both quantitative and qualitative data, providing a more 'in-depth' understanding of how both environmental and genetic risks or benefits may be perceived and evaluated. Madill

and Gough (2008) highlight how qualitative methods have a place within psychological science through the benefits of mixed methods work. Utilising multiple methods regarding the same topic can allow for elaboration, enhancement, and clarification of findings across data. That is, mixed methods research combines “the power of stories and the power of numbers” (Pluye & Hong, 2014, p.30).

This was the case in the current research, as in depth thematic analysis of parental decision-making considerations allowed for increased understanding of the quantitative results; for example, with more parents choosing to allow their child to participate in football (soccer) than rugby, despite this not reflecting actual injury risk (Quarrie et al., 2017). Suggestions that combined methods can be more utilitarian (Madill & Gough, 2008) and pragmatic (Johnson & Onwuegbuzie, 2004) are also evidenced in my work, as asking what is considered instead of immediately providing options can reveal new influential factors important in creating effective attitudes/behaviour change programmes in the ‘real world’. Such mixed methods approaches have been described as particularly important in prevention research due to the complex role of human behaviour and decision making (Zhang & Watanabe-Galloway, 2014). The approach has been used in a range of preventative research areas including disease management, HIV prevention, and smoking cessation, and allows for the combination of more generalisable (to other populations) quantitative findings, and specific in-depth insights from qualitative analyses (Zhang & Watanabe-Galloway, 2014).

While generating new knowledge, the survey had some limitations that should be addressed in future work. For example, examining parental attitudes from a life-course perspective could further shed light on how parental attitudes, knowledge, and behaviour, could influence those of their children as they age. If parents were informed of a potential risk in contact sports would they for example encourage their child to participate in an alternative sport? The risk of losing the benefits of participation in sport may not be as great if evidence could be provided that removal from contact sports due to parental concerns was not a cause for overall withdrawal, lack of parent support, or child enthusiasm for fitness activities in general. Additionally, whilst the importance of fitness in childhood is clear, exercise is also considered an element in the STAC-R model of cognitive health at a later compensatory scaffolding

level as an intervention (Reuter-Lorenz & Park, 2014). How much influence would parent's removal or restricting of certain sports have on a child's later willingness to be involved in exercise throughout their life? As identified earlier, future work would also ideally investigate concussion and physical activity alongside other health topics. This would expand on the current study's inclusion of overall sports-allowed measure and general health risk attitudes (DOSPERT). This would allow for identification of impacting factors on decision-making that are specific to one health-risk or all health considerations in general – a key topic as the TRA/TPB model suggests the best predictor of behaviour is a more specific behaviour-based attitude that may not apply across different situations. Such work can carry over to intervention and policy work that would be could be most successful if adapted to the topic and individual needs.

Implications for the development of future interventions

Whilst researchers are now considering cognitive health from a probabilistic life-span multi-factorial perspective, the general public is instead typically exposed to media headlines warning that 'this [factor] *causes* dementia' or 'this [treatment] will cure dementia'. My work demonstrates a starting point for combining health psychology and the emerging field of health neuroscience to build a greater understanding of the biological and environmental factors that could influence cognitive health over a life-time, but also suggests how findings could be taken to the public. These results could transfer to the 'real world', supporting behaviour changing initiatives and knowledge transfer programmes and engagement projects. That is to say, there is unlikely to be a 'magic bullet' for later life decline, but rather, people need to be informed about the usefulness of multiple 'marginal gains' across the lifespan.

My research suggests a public misperception of risk, and a lack of knowledge with regards to both endogenous (i.e. genetic) and potentially modifiable factors influencing life-span cognitive health. It is important that people have access to such modifying activities, as well as other forms of social activities that may be equally important considering my current findings and the potential need to benefit from the contributions of multiple factors. Research continues to be conducted on a number of interventions aiming to increase hippocampal volume and reduce current and future

symptomology in a range of disorders (Fotuhi et al., 2012). In the context of late-life, for example, Initiatives such as 'Dementia Friendly Communities' aim to build intergenerational relationships, a supportive aware community, and facilitate access to information and services for those in need (Van der Linden & Juillerat Van der Linden, 2016). My research supports the importance of such programmes, finding poor service awareness. Programmes in Wales also aim to provide physical activity opportunities to children and at-risk adults who may have their access to such an intervention limited by another aspect of the STAC-R model such as socioeconomic status (Reuter-Lorenz & Park, 2014). The National Exercise Referral Scheme (<http://wlga.wales/national-exercise-referral-scheme-ners>), for example, provides reduced cost fitness programs for adults at risk of chronic disease. It aims to influence life-course behaviour, encouraging participation in exercise for both physical and mental benefits. In the case of younger individuals, The Active Project provides fitness class vouchers for teenagers of all fitness levels (Wightwick, 2017), offering choice, removing or limiting the cost, and treating children equally. Such a scheme could provide access to new activities and change attitudes towards exercise but, of particular interest, could also be less susceptible to parental influence (in the case of teenagers who receive money from parents for specific activities).

My work also raises concerns regarding public knowledge and perception of genetic risk, something identified in work on public understanding of science (eg. Carver, Castéra, Gericke, Evangelista, & El-Hani, 2017). Work in this area has shown that the public have rather limited knowledge of genetics. The public tend to overemphasize the importance of genes, and have difficulty understanding the notion that genetic and environmental factors interact (Carver et al., 2017). The qualitative component of my research revealed evidence for genetic fatalism in the context of concussion and brain injury, that is to say, the belief that genetic risks are unchangeable and cannot be prevented. Such views are apparent in media reporting (Carver et al., 2017), which clearly goes against the aims of effective science communication, and could reinforce the fatalistic attitudes as represented in my thematic analysis, and possible lack of uptake or withdrawal of oneself or children from potentially neurostructural and cognitively beneficial health behaviours, such as participation in physical activity.

Interestingly, my findings are consistent with other work (e.g. Carver et al., 2017) showing that this may not simply be a result of misunderstanding or simplification of science (e.g. by the media) but could be anchored in deeper fatalistic beliefs. For example, some people expressed the belief that God plays an important role in determining health outcomes throughout life. It remains a real challenge to improve public understanding of the probabilistic nature of genetic risk and the implications for behaviour modification. Given the difficulties of public understanding of science, future work could investigate the effects of other forms of knowledge transfer, including narrative communication (Hinyard & Kreuter, 2007). Narrative health communication is a form of persuasive communication in which a health message is presented in the form of a fictional or nonfictional story, as opposed to being presented as statistical evidence or arguments to promote health-related behaviours. Future research could determine the impact of such narratives (e.g. the recent Will Smith movie “Concussion”) on public attitudes and behaviours.

The key to lifespan cognitive health is not simple. It involves multiple interacting factors, whose roles can change and develop through environmental events and in the course of natural aging. Continued research will build on current models, such as STAC-R, providing greater understanding of genetic-neural-cognitive-behaviour links, and suggesting potential new interventions. Such scientific findings need to be effectively and sensitively delivered to the public, aiming to influence social norms, change misperceptions, be integrated into service provision, and support all individuals in living as healthy a life as possible.

References

- Aalfs, C. M., Smets, E. M., de Haes, H. C., & Leschot, N. J. (2003). Referral for genetic counselling during pregnancy: limited alertness and awareness about genetic risk factors among GPs. *Family Practice, 20*(2), 135–141. <http://doi.org/10.1093/fampra/20.2.135>
- Adams, R. C., Sumner, P., Vivian-Griffiths, S., Barrington, A., Williams, A., Boivin, J., ... Bott, L. (2017). How readers understand causal and correlational expressions used in news headlines. *Journal of Experimental Psychology: Applied, 23*(1), 1–14. <http://doi.org/10.1037/xap0000100>
- Ahmed, O. H., & Hall, E. E. (2016). "It was only a mild concussion": Exploring the description of sports concussion in online news articles. *Physical Therapy in Sport : Official Journal of the Association of Chartered Physiotherapists in Sports Medicine, 23*, 7–13. <http://doi.org/10.1016/j.ptsp.2016.07.003>
- Ahmed, O. H., Sullivan, S. J., Schneiders, A. G., & McCrory, P. R. (2012). Concussion information online: evaluation of information quality, content and readability of concussion-related websites. *British Journal of Sports Medicine, 46*(9), 675–83. <http://doi.org/10.1136/bjism.2010.081620>
- Ajzen, I. (1991). The theory of planned behavior. *Organizational Behavior and Human Decision Processes, 50*, 179–211. [http://doi.org/10.1016/0749-5978\(91\)90020-T](http://doi.org/10.1016/0749-5978(91)90020-T)
- Ajzen, I. (2011). The theory of planned behaviour: Reactions and reflections. *Psychology & Health, 26*(9), 1113–1127. <http://doi.org/10.1080/08870446.2011.613995>
- Ajzen, I., Joyce, N., Sheikh, S., & Cote, N. G. (2011). Knowledge and the Prediction of Behavior: The Role of Information Accuracy in the Theory of Planned Behavior. *Basic and Applied Social Psychology, 33*(2), 101–117. <http://doi.org/10.1080/01973533.2011.568834>
- Alex, D., Charlene, H., Jeanne, L., Anthony, D., Louis, O., Li-Shan, C., & Paul, van D. (2007). Cancelling planned actions following mild traumatic brain injury. *Neuropsychologia, 45*(2), 406–411. <http://doi.org/10.1016/J.NEUROPSYCHOLOGIA.2006.06.008>
- Alexander-Bloch, A., Giedd, J. N., & Bullmore, E. (2013). Imaging structural co-variance between human brain regions. *Nat Rev Neurosci, 14*(5), 322–336. <http://doi.org/10.1038/nrn3465>
- Allender, S., Cowburn, G., & Foster, C. (2006). Understanding participation in sport and physical activity among children and adults: A review of qualitative studies. *Health Education Research, 21*(6), 826–835. <http://doi.org/10.1093/her/cyl063>
- Angelucci, F., Brenè, S., & Mathé, a a. (2005). BDNF in schizophrenia, depression and corresponding animal models. *Molecular Psychiatry, 10*(4), 345–352. <http://doi.org/10.1038/sj.mp.4001637>
- Anstey, K. J. (2014). Optimizing cognitive development over the life course and preventing cognitive decline: Introducing the Cognitive Health Environment Life Course Model (CHELM). *International Journal of Behavioral Development, 38*(1), 1–10. <http://doi.org/10.1177/0165025413512255>

- Armitage, C. J., & Conner, M. (2001). Efficacy of the Theory of Planned Behaviour: a meta-analytic review. *The British Journal of Social Psychology / the British Psychological Society*, 40(Pt 4), 471–499. <http://doi.org/10.1348/014466601164939>
- Arthur, W., & Day, D. V. (1994). Development of a Short form for the Raven Advanced Progressive Matrices Test. *Educational and Psychological Measurement*, 54(2), 394–403. <http://doi.org/10.1177/0013164494054002013>
- Atlas, L. Y., & Wager, T. D. (2012). How expectations shape pain. *Neuroscience Letters*, 520(2), 140–148. <http://doi.org/10.1016/j.neulet.2012.03.039>
- Aubrey, J. B., Dobbs, a R., & Rule, B. G. (1989). Laypersons' knowledge about the sequelae of minor head injury and whiplash. *Journal of Neurology, Neurosurgery, and Psychiatry*, 52(7), 842–6.
- Bailey, D. M., Jones, D. W., Sinnott, A., Brugniaux, J. V., New, K. J., Hodson, D., ... Ainslie, P. N. (2013). Impaired cerebral haemodynamic function associated with chronic traumatic brain injury in professional boxers. *Clinical Science*, 124(3), 177–189. <http://doi.org/10.1042/CS20120259>
- Baker, J. F., Devitt, B. M., Green, J., & McCarthy, C. (2013). Concussion among under 20 rugby union players in Ireland: incidence, attitudes and knowledge. *Irish Journal of Medical Science*, 182(1), 121–5. <http://doi.org/10.1007/s11845-012-0846-1>
- Baquin, P., & Brukner, P. (1997). Injuries Presenting to an Australian Sports Medicine Centre: A 12-Month Study.
- Barbey, A. K., Colom, R., Paul, E., Forbes, C., Krueger, F., Goldman, D., & Grafman, J. (2014). Preservation of general intelligence following traumatic brain injury: Contributions of the Met66 brain-derived neurotrophic factor. *PLoS ONE*, 9(2), 1–8. <http://doi.org/10.1371/journal.pone.0088733>
- Barker, G. R. I., Banks, P. J., Scott, H., Ralph, G. S., Mitrophanous, K. A., Wong, L.-F., ... Warburton, E. C. (2017). Separate elements of episodic memory subserved by distinct hippocampal–prefrontal connections. *Nature Neuroscience*, 20(2), 242–250. <http://doi.org/10.1038/nn.4472>
- Baumgart, M., Snyder, H. M., Carrillo, M. C., Fazio, S., Kim, H., & Johns, H. (2015). Summary of the evidence on modifiable risk factors for cognitive decline and dementia: A population-based perspective. *Alzheimer's & Dementia*, 11(6), 718–726. <http://doi.org/10.1016/j.jalz.2015.05.016>
- Beauchamp, M. H., Ditchfield, M., Maller, J. J., Catroppa, C., Godfrey, C., Rosenfeld, J. V., ... Anderson, V. A. (2011). Hippocampus, amygdala and global brain changes 10 years after childhood traumatic brain injury. *Int. J. Devl Neuroscience International Journal of Developmental Neuroscience*, 29, 137–143. <http://doi.org/10.1016/j.ijdevneu.2010.12.003>
- Beaudoin, M., & Desrichard, O. (2011). Are memory self-efficacy and memory performance related? A meta-analysis. *Psychological Bulletin*, 137(2), 211–241. <http://doi.org/10.1037/a0022106>
- Biedermann, S. V., Fuss, J., Steinle, J., Auer, M. K., Dormann, C., Falfán-Melgoza, C., ...

- Weber-Fahr, W. (2016). The hippocampus and exercise: histological correlates of MR-detected volume changes. *Brain Structure and Function*, 221(3), 1353–1363. <http://doi.org/10.1007/s00429-014-0976-5>
- Blais, A.-R., & Weber, E. U. (2006). A Domain-specific Risk-taking (DOSPERT) Scale for Adult Populations. *Judgement and Decision Making*, 1, 33–47.
- Blanc, F., Colloby, S. J., Philippi, N., de Pétigny, X., Jung, B., Demuynck, C., ... Taylor, J.-P. (2015). Cortical Thickness in Dementia with Lewy Bodies and Alzheimer's Disease: A Comparison of Prodromal and Dementia Stages. *PLoS One*, 10(6), e0127396. <http://doi.org/10.1371/journal.pone.0127396>
- Blennow, K., Hardy, J., & Zetterberg, H. (2012). The neuropathology and neurobiology of traumatic brain injury. *Neuron*, 76(5), 886–99. <http://doi.org/10.1016/j.neuron.2012.11.021>
- Bloodgood, B., Inokuchi, D., Shawver, W., Olson, K., Hoffman, R., Cohen, E., ... Muthuswamy, K. (2013). Exploration of awareness, knowledge, and perceptions of traumatic brain injury among American youth athletes and their parents. *The Journal of Adolescent Health : Official Publication of the Society for Adolescent Medicine*, 53(1), 34–9. <http://doi.org/10.1016/j.jadohealth.2013.01.022>
- Bohnen, N., Jolles, J., Twijnstra, A., Mellink, R., & Sulon, J. (1992). Coping styles, cortisol reactivity, and performance in a vigilance task of patients with persistent postconcussive symptoms after a mild head injury. *The International Journal of Neuroscience*, 64(1–4), 97–105.
- Boots, E. A., Schultz, S. A., Clark, L. R., Racine, A. M., Darst, B. F., Kosciak, R. L., ... Okonkwo, O. C. (2017). BDNF Val66Met predicts cognitive decline in the Wisconsin Registry for Alzheimer's Prevention. *Neurology*, 88(22), 2098–2106. <http://doi.org/10.1212/WNL.0000000000003980>
- Borba, E. M., Duarte, J. A., Bristot, G., Scotton, E., Camozzato, A. L., & Chaves, M. L. F. (2016). Brain-Derived Neurotrophic Factor Serum Levels and Hippocampal Volume in Mild Cognitive Impairment and Dementia due to Alzheimer Disease. *Dementia and Geriatric Cognitive Disorders Extra*, 91, 559–567. <http://doi.org/10.1159/000450601>
- Braham, R. a, Finch, C. F., McIntosh, a, & McCrory, P. (2004). Community football players' attitudes towards protective equipment--a pre-season measure. *British Journal of Sports Medicine*, 38(4), 426–30. <http://doi.org/10.1136/bjism.2002.004051>
- Braun, V., & Clarke, V. (2006). Using Thematic Analysis in Psychology. *Qualitative Research in Psychology*, 3(2), 77–101. <http://doi.org/10.1191/1478088706qp063oa>
- Brisbourne, R. (2017). Football and dementia. Retrieved from <https://www.dementiablog.org/in-the-news-football-and-dementia/>
- Canivet, A., Albinet, C. T., André, N., Pylouster, J., Rodríguez-Ballesteros, M., Kitzis, A., & Audiffren, M. (2015). Effects of BDNF polymorphism and physical activity on episodic memory in the elderly: a cross sectional study. *European Review of Aging and Physical Activity*, 12(1), 15. <http://doi.org/10.1186/s11556-015-0159-2>

- Carlson, M. C., Helms, M. J., Steffens, D. C., Burke, J. R., Potter, G. G., & Plassman, B. L. (2008). Midlife activity predicts risk of dementia in older male twin pairs. *Alzheimer's & Dementia : The Journal of the Alzheimer's Association*, 4(5), 324–31. <http://doi.org/10.1016/j.jalz.2008.07.002>
- Carson, A. (2017). Concussion, dementia and CTE: are we getting it very wrong? *Journal of Neurology, Neurosurgery & Psychiatry*, 88(6), 462–464. <http://doi.org/10.1136/jnnp-2016-315510>
- Carver, R. B., Castéra, J., Gericke, N., Evangelista, N. A. M., & El-Hani, C. N. (2017). Young Adults' Belief in Genetic Determinism, and Knowledge and Attitudes towards Modern Genetics and Genomics: The PUGGS Questionnaire. *PLOS ONE*, 12(1), e0169808. <http://doi.org/10.1371/journal.pone.0169808>
- Caseras, X., Tansey, K. E., Foley, S., & Linden, D. (2015). Association between genetic risk scoring for schizophrenia and bipolar disorder with regional subcortical volumes. *Translational Psychiatry*, 5(12), e692. <http://doi.org/10.1038/tp.2015.195>
- Chattarji, S., Tomar, A., Suvrathan, A., Ghosh, S., & Rahman, M. M. (2015). Neighborhood matters: divergent patterns of stress-induced plasticity across the brain. *Nature Neuroscience*, 18(10), 1364–1375. <http://doi.org/10.1038/nn.4115>
- Chen, H.-Y. (2015). *Are There Multiple Kinds of Episodic Memory? An fMRI Investigation Comparing Autobiographical and Recognition Memory Tasks.*
- Chen, W., Chen, C., Xia, M., Wu, K., Chen, C., He, Q., ... Dong, Q. (2016). Interaction Effects of BDNF and COMT Genes on Resting-State Brain Activity and Working Memory. *Frontiers in Human Neuroscience*, 10, 540. <http://doi.org/10.3389/fnhum.2016.00540>
- Cheung, A. M., Mitsis, E. M., & Halperin, J. M. (2004). The Relationship of Behavioral Inhibition to Executive Functions in Young Adults. *Journal of Clinical and Experimental Neuropsychology*, 26(3), 393–404. <http://doi.org/10.1080/13803390490510103>
- Chiesi, F., Ciancaleoni, M., Galli, S., & Primi, C. (2012). Using the Advanced Progressive Matrices (Set I) to assess fluid ability in a short time frame: An item response theory-based analysis. *Psychological Assessment*, 24(4), 892–900. <http://doi.org/10.1037/a0027830>
- Choi, S.-W., Shin, Y.-C., Mok, J. Y., Kim, D.-J., Choi, J.-S., & Hwang, S. S.-H. (2016). Serum BDNF levels in patients with gambling disorder are associated with the severity of gambling disorder and Iowa Gambling Task indices. *Journal of Behavioral Addictions*, 5(1), 135–139. <http://doi.org/10.1556/2006.5.2016.010>
- Chrisman, S. P., Quitiquit, C., & Rivara, F. P. (2013a). Qualitative study of barriers to concussive symptom reporting in high school athletics. *The Journal of Adolescent Health : Official Publication of the Society for Adolescent Medicine*, 52(3), 330–335.e3. <http://doi.org/10.1016/j.jadohealth.2012.10.271>
- Chrisman, S. P., Quitiquit, C., & Rivara, F. P. (2013b). Qualitative study of barriers to concussive symptom reporting in high school athletics. *The Journal of Adolescent Health : Official Publication of the Society for Adolescent Medicine*, 52(3), 330–

335.e3. <http://doi.org/10.1016/j.jadohealth.2012.10.271>

- Cicchetti, D., & Blender, J. A. (2006). A multiple-levels-of-analysis perspective on resilience: Implications for the developing brain, neural plasticity, and preventive interventions. *Annals of the New York Academy of Sciences*, *1094*, 248–258. <http://doi.org/10.1196/annals.1376.029>
- Colzato, L. S., Van der Does, A. J. W., Kouwenhoven, C., Elzinga, B. M., & Hommel, B. (2011). BDNF Val66Met polymorphism is associated with higher anticipatory cortisol stress response, anxiety, and alcohol consumption in healthy adults. *Psychoneuroendocrinology*, *36*(10), 1562–1569. <http://doi.org/10.1016/j.psyneuen.2011.04.010>
- Cook, D. J., Cusimano, M. D., Tator, C. H., & Chipman, M. L. (2003). Evaluation of the ThinkFirst Canada, Smart Hockey, brain and spinal cord injury prevention video. *Injury Prevention : Journal of the International Society for Child and Adolescent Injury Prevention*, *9*(4), 361–6.
- Crowe, M., Andel, R., Pedersen, N. L., Johansson, B., & Gatz, M. (2003). Does participation in leisure activities lead to reduced risk of Alzheimer's disease? A prospective study of Swedish twins. *The Journals of Gerontology. Series B, Psychological Sciences and Social Sciences*, *58*(5), P249-55.
- Cusimano, M. D., Zhang, S., Topolovec-Vranic, J., Hutchison, M. G., & Jing, R. (2017). Factors affecting the concussion knowledge of athletes, parents, coaches, and medical professionals. *SAGE Open Medicine*, *5*, 205031211769479. <http://doi.org/10.1177/2050312117694794>
- Dale, A. M., Fischl, B., & Sereno, M. I. (1999). Cortical Surface-Based Analysis. *NeuroImage*, *9*(2), 179–194. <http://doi.org/10.1006/nimg.1998.0395>
- Dar-Nimrod, I., & Heine, S. J. (2011). Genetic essentialism: on the deceptive determinism of DNA. *Psychological Bulletin*, *137*(5), 800–18. <http://doi.org/10.1037/a0021860>
- Davies, R., & McMillan, T. M. (2005). Opinion about post-concussion syndrome in health professionals. *Brain Injury : [BI]*, *19*(11), 941–7.
- Deary, I. (2008). Why do intelligent people live longer? *Nature*, *456*(7219), 175–176. <http://doi.org/10.1038/456175a>
- Delvecchio, G., Fossati, P., Boyer, P., Brambilla, P., Falkai, P., Gruber, O., ... Frangou, S. (2012). Common and distinct neural correlates of emotional processing in Bipolar Disorder and Major Depressive Disorder: a voxel-based meta-analysis of functional magnetic resonance imaging studies. *European Neuropsychopharmacology : The Journal of the European College of Neuropsychopharmacology*, *22*(2), 100–13. <http://doi.org/10.1016/j.euroneuro.2011.07.003>
- Déry, N., Pilgrim, M., Gibala, M., Gillen, J., Wojtowicz, J. M., MacQueen, G., & Becker, S. (2013). Adult hippocampal neurogenesis reduces memory interference in humans: opposing effects of aerobic exercise and depression. *Frontiers in Neuroscience*, *7*, 66. <http://doi.org/10.3389/fnins.2013.00066>

- Dewitt, D. S., Perez-Polo, R., Hulsebosch, C. E., Dash, P. K., & Robertson, C. S. (2013). Challenges in the development of rodent models of mild traumatic brain injury. *Journal of Neurotrauma*, *30*(9), 688–701. <http://doi.org/10.1089/neu.2012.2349>
- Division, U. N. D. of E. and S. A. P. (2015). *World Population Aging 2015*. NY.
- Dong, M. Y., Sandberg, K., Bibby, B. M., Pedersen, M. N., & Overgaard, M. (2015). The development of a sense of control scale. *Frontiers in Psychology*, *6*, 1733. <http://doi.org/10.3389/fpsyg.2015.01733>
- Doolan, A. W., Day, D. D., Maerlender, A. C., Goforth, M., & Gunnar Brolinson, P. (2012). A review of return to play issues and sports-related concussion. *Annals of Biomedical Engineering*, *40*(1), 106–13. <http://doi.org/10.1007/s10439-011-0413-3>
- Dooley, L. N., Ganz, P. A., Cole, S. W., Crespi, C. M., & Bower, J. E. (2016). Val66Met BDNF polymorphism as a vulnerability factor for inflammation-associated depressive symptoms in women with breast cancer. *Journal of Affective Disorders*, *197*, 43–50. <http://doi.org/10.1016/j.jad.2016.02.059>
- dos Santos, T. M., Kolling, J., Siebert, C., Biasibetti, H., Bertó, C. G., Grun, L. K., ... Wyse, A. T. S. (2017). Effects of previous physical exercise to chronic stress on long-term aversive memory and oxidative stress in amygdala and hippocampus of rats. *International Journal of Developmental Neuroscience*, *56*, 58–67. <http://doi.org/10.1016/j.ijdevneu.2016.12.003>
- Dregan, A., & Gulliford, M. C. (2013). Leisure-time physical activity over the life course and cognitive functioning in late mid-adult years: a cohort-based investigation. *Psychological Medicine*, *43*(11), 2447–2458. <http://doi.org/10.1017/S0033291713000305>
- Dretsch, M. N., Silverberg, N., Gardner, A. J., Panenka, W. J., Emmerich, T., Crynen, G., ... Iverson, G. L. (2017). Genetics and Other Risk Factors for Past Concussions in Active-Duty Soldiers. *Journal of Neurotrauma*, *34*(4), 869–875. <http://doi.org/10.1089/neu.2016.4480>
- Du, X., Luo, W., Shen, Y., Wei, D., Xie, P., Zhang, J., ... Qiu, J. (2015). Brain structure associated with automatic thoughts predicted depression symptoms in healthy individuals. *Psychiatry Research: Neuroimaging*, *232*(3), 257–263. <http://doi.org/10.1016/j.psychresns.2015.03.002>
- Ducharme, S., Albaugh, M. D., Nguyen, T.-V., Hudziak, J. J., Mateos-Pérez, J. M., Labbe, A., ... Brain Development Cooperative Group. (2016). Trajectories of cortical thickness maturation in normal brain development--The importance of quality control procedures. *NeuroImage*, *125*, 267–279. <http://doi.org/10.1016/j.neuroimage.2015.10.010>
- Eagly, A. H., & Chaiken, S. (2007). The Advantages of an Inclusive Definition of Attitude. *Social Cognition*, *25*(5), 582–602. <http://doi.org/10.1521/soco.2007.25.5.582>
- Egan, M. F., Kojima, M., Callicott, J. H., Goldberg, T. E., Kolachana, B. S., Bertolino, A., ... Weinberger, D. R. (2003). The BDNF val66met polymorphism affects activity-dependent secretion of BDNF and human memory and hippocampal function. *Cell*, *112*(2), 257–69.

- Elman, J. A., Oh, H., Madison, C. M., Baker, S. L., Vogel, J. W., Marks, S. M., ... Jagust, W. J. (2014). Neural compensation in older people with brain amyloid- β deposition. *Nature Neuroscience*, *17*(10), 1316–8. <http://doi.org/10.1038/nn.3806>
- Erickson, K., Gildengers, A., & Butters, M. (2013). Physical activity and brain plasticity in late adulthood. *Dialogues in Clinical Neuroscience*, *15*(1), 99–108. <http://doi.org/10.4081/ar.2012.e6>
- Erickson, K., Hillman, C. H., & Kramer, A. F. (2015). Physical activity, brain, and cognition. *Current Opinion in Behavioral Sciences*, *4*, 27–32. <http://doi.org/10.1016/j.cobeha.2015.01.005>
- Erickson, K. I., Banducci, S. E., Weinstein, A. M., MacDonald, A. W., Ferrell, R. E., Halder, I., ... Manuck, S. B. (2013). The Brain-Derived Neurotrophic Factor Val66Met Polymorphism Moderates an Effect of Physical Activity on Working Memory Performance. *Psychological Science*, *24*(9), 1770–1779. <http://doi.org/10.1177/0956797613480367>
- Erickson, K. I., Creswell, J. D., Verstynen, T. D., & Gianaros, P. J. (2014). Health Neuroscience: Defining a New Field. *Current Directions in Psychological Science*, *23*(6), 446–453. <http://doi.org/10.1177/0963721414549350>
- Erickson, K. I., Voss, M. W., Prakash, R. S., Basak, C., Szabo, A., Chaddock, L., ... Kramer, A. F. (2011). Exercise training increases size of hippocampus and improves memory. *Proceedings of the National Academy of Sciences of the United States of America*, *108*(7), 3017–22. <http://doi.org/10.1073/pnas.1015950108>
- Erickson, K., Raji, C. A., Lopez, O. L., Becker, J. T., Rosano, C., Newman, A. B., ... Kuller, L. H. (2010). Physical activity predicts gray matter volume in late adulthood: the Cardiovascular Health Study. *Neurology*, *75*(16), 1415–22. <http://doi.org/10.1212/WNL.0b013e3181f88359>
- Erickson, Miller, L., & Roecklein, A. (2012). The Aging Hippocampus. *The Neuroscientist*, *18*(1), 82–97. <http://doi.org/10.1177/1073858410397054>
- Evans, A. C. (2013). Networks of anatomical covariance. *NeuroImage*, *80*, 489–504. <http://doi.org/10.1016/j.neuroimage.2013.05.054>
- Fakhran, S., Yaeger, K., & Alhilali, L. (2013). Changes in Mild Traumatic Brain Injury Resemble Pathologic Features of Early Alzheimer. *Radiology*, *269*(1), 249–257.
- Fastenrath, M., Coynel, D., Spalek, K., Milnik, A., Gschwind, L., Roozendaal, B., ... de Quervain, D. J. F. (2014). Dynamic Modulation of Amygdala-Hippocampal Connectivity by Emotional Arousal. *Journal of Neuroscience*, *34*(42), 13935–13947. <http://doi.org/10.1523/JNEUROSCI.0786-14.2014>
- Fedor, A., & Gunstad, J. (2016). Would You Let Your Child Play Football? Attitudes Toward Football Safety. *Applied Neuropsychology: Child*, *5*(2), 107–109. <http://doi.org/10.1080/21622965.2014.999770>
- Finch, C. F., McIntosh, A. S., & McCrory, P. (2001). What do under 15 year old schoolboy rugby union players think about protective headgear? *British Journal of Sports Medicine*, *35*(2), 89–94.
- Findler, P. (2015). Should Kids Play (American) Football? *Journal of the Philosophy of*

Sport, 42(3), 443–462. <http://doi.org/10.1080/00948705.2015.1079132>

- Firth, J., Stubbs, B., Vancampfort, D., Schuch, F., Lagopoulos, J., Rosenbaum, S., & Ward, P. B. (2018). Effect of aerobic exercise on hippocampal volume in humans: A systematic review and meta-analysis. *NeuroImage*, 166(April 2017), 230–238. <http://doi.org/10.1016/j.neuroimage.2017.11.007>
- Fischl, B., Salat, D. H., Busa, E., Albert, M., Dieterich, M., Haselgrove, C., ... Dale, A. M. (2002). Whole brain segmentation: automated labeling of neuroanatomical structures in the human brain. *Neuron*, 33(3), 341–55.
- Fjell, A. M., Mcevoy, L., Holland, D., Dale, A. M., Walhovd, K. B., & Neuroimaging, D. (2014). Progress in Neurobiology What is normal in normal aging ? Effects of aging , amyloid and Alzheimer ' s disease on the cerebral cortex and the hippocampus, 117, 20–40.
- Fotuhi, M., Do, D., & Jack, C. (2012). Modifiable factors that alter the size of the hippocampus with ageing. *Nature Reviews Neurology*, 8(4), 189–202. <http://doi.org/10.1038/nrneurol.2012.27>
- Furnham, A. (1981). Personality and activity preference. *British Journal of Social Psychology*, 20(1), 57–68. <http://doi.org/10.1111/j.2044-8309.1981.tb00474.x>
- Gardner, A., Kay-Lambkin, F., Stanwell, P., Donnelly, J., Williams, W. H., Hiles, A., ... Jones, D. K. (2012). A systematic review of diffusion tensor imaging findings in sports-related concussion. *Journal of Neurotrauma*, 29(16), 2521–38. <http://doi.org/10.1089/neu.2012.2628>
- Gardner, A., Shores, E. A., & Batchelor, J. (2010). Reduced processing speed in rugby union players reporting three or more previous concussions. *Archives of Clinical Neuropsychology : The Official Journal of the National Academy of Neuropsychologists*, 25(3), 174–81. <http://doi.org/10.1093/arclin/acq007>
- Godin, G., Conner, M., & Sheeran, P. (2005). Bridging the intention-behaviour gap: The role of moral norm. *British Journal of Social Psychology*, 44(4), 497–512. <http://doi.org/10.1348/014466604X17452>
- Goh, J., & Park, D. C. (2009). Neuroplasticity and cognitive aging. *Restor Neurol Neurosci*, 27(5), 391–403. <http://doi.org/10.3233/RNN-2009-0493>. Neuroplasticity
- Goldman, A. L., Pezawas, L., Mattay, V. S., Fischl, B., Verchinski, B. a, Chen, Q., ... Meyer-Lindenberg, A. (2009). Widespread reductions of cortical thickness in schizophrenia and spectrum disorders and evidence of heritability. *Archives of General Psychiatry*, 66(5), 467–77. <http://doi.org/10.1001/archgenpsychiatry.2009.24>
- Halfon, N., & Hochstein, M. (2002). Life Course Health Development: An Integrated Framework for Developing Health, Policy, and Research. *Milbank Quarterly*, 80(3), 433–479. <http://doi.org/10.1111/1468-0009.00019>
- Harmon, K. G., Drezner, J. a, Gammons, M., Guskiewicz, K. M., Halstead, M., Herring, S. a, ... Roberts, W. O. (2013). American Medical Society for Sports Medicine position statement: concussion in sport. *British Journal of Sports Medicine*, 47(1), 15–26. <http://doi.org/10.1136/bjsports-2012-091941>

- Harrisberger, F., Spalek, K., Smieskova, R., Schmidt, A., Coynel, D., Milnik, A., ... Borgwardt, S. (2014). The association of the BDNF Val66Met polymorphism and the hippocampal volumes in healthy humans: A joint meta-analysis of published and new data. *Neuroscience & Biobehavioral Reviews*, *42*, 267–278. <http://doi.org/10.1016/j.neubiorev.2014.03.011>
- Hayes, A. F. (2013). *Introduction to mediation, moderation, and conditional process analysis: a regression-based approach*. New York: The Guilford Press.
- Hayes, J. P., Logue, M. W., Sadeh, N., Spielberg, J. M., Verfaellie, M., Hayes, S. M., ... Miller, M. W. (2017). Mild traumatic brain injury is associated with reduced cortical thickness in those at risk for Alzheimer's disease. *Brain*, *140*(3), aww344. <http://doi.org/10.1093/brain/aww344>
- Hayes, J., Reagan, A., Logue, M. W., Hayes, S. M., Sadeh, N., Miller, D. R., ... Miller, M. W. (2017). BDNF genotype is associated with hippocampal volume in mild traumatic brain injury. *Genes, Brain and Behavior*. <http://doi.org/10.1111/gbb.12403>
- Heine, S. J., Dar-Nimrod, I., Cheung, B. Y., & Proulx, T. (2017). Essentially Biased: Why People Are Fatalistic About Genes. *Advances in Experimental Social Psychology*, *55*, 137–192. <http://doi.org/10.1016/BS.AESP.2016.10.003>
- Henwood, K. L., & Pidgeon, N. F. (1992). Qualitative research and psychological theorizing. *British Journal of Psychology*, *83*(1), 97–111. <http://doi.org/10.1111/j.2044-8295.1992.tb02426.x>
- Hermans, E. J., Kanen, J. W., Tambini, A., Fernández, G., Davachi, L., & Phelps, E. A. (2016). Persistence of Amygdala–Hippocampal Connectivity and Multi-Voxel Correlation Structures During Awake Rest After Fear Learning Predicts Long-Term Expression of Fear. *Cerebral Cortex*, *27*(5), bhw145. <http://doi.org/10.1093/cercor/bhw145>
- Herrmann, S. D., Heumann, K. J., Der Ananian, C. A., & Ainsworth, B. E. (2013). Validity and reliability of the global physical activity questionnaire (GPAQ). *Measurement in Physical Education and Exercise Science*, *17*(3), 221–235. <http://doi.org/10.1080/1091367X.2013.805139>
- Herting, M. M., Keenan, M. F., & Nagel, B. J. (2016). Aerobic Fitness Linked to Cortical Brain Development in Adolescent Males: Preliminary Findings Suggest a Possible Role of BDNF Genotype. *Frontiers in Human Neuroscience*, *10*(June), 327. <http://doi.org/10.3389/fnhum.2016.00327>
- Hether, H. J., Huang, G. C., Beck, V., Murphy, S. T., & Valente, T. W. (2008). Entertainment-Education in a Media-Saturated Environment: Examining the Impact of Single and Multiple Exposures to Breast Cancer Storylines on Two Popular Medical Dramas. *Journal of Health Communication*, *13*, 808–823. <http://doi.org/10.1080/10810730802487471>
- Hight, N. J., Hickie, I. B., & Davenport, T. A. (2002). Monitoring awareness of and attitudes towards depression in Australia. *Depression and the Community*.
- Hinyard, L. J., & Kreuter, M. W. (2007). Using narrative communication as a tool for health behavior change: A conceptual, theoretical, and empirical overview. *Health*

- Education and Behavior*, 34(5), 777–792.
<http://doi.org/10.1177/1090198106291963>
- Huang, E. J., & Reichardt, L. F. (2001). N EURO TROPHINS : Roles in Neuronal Development and Function. *Annual Review of Neuroscience*, 24(1), 677–736.
<http://doi.org/10.1146/annurev.neuro.24.1.677>
- Ide, S., Kakeda, S., Watanabe, K., Yoshimura, R., Abe, O., Hayashi, K., ... Korogi, Y. (2015). Relationship between a BDNF gene polymorphism and the brain volume in treatment-naive patients with major depressive disorder: A VBM analysis of brain MRI. *Psychiatry Research: Neuroimaging*, 233(2), 120–124.
<http://doi.org/10.1016/j.pscychresns.2015.05.016>
- Izquierdo, I., Furini, C. R. G., & Myskiw, J. C. (2016). Fear Memory. *Physiological Reviews*, 96(2), 695–750. <http://doi.org/10.1152/physrev.00018.2015>
- Jagust, W. J. (2016). Early life sets the stage for aging. *Proceedings of the National Academy of Sciences*, 113(33), 9148–9150.
<http://doi.org/10.1073/pnas.1609720113>
- Jagust, W. J., & Mormino, E. C. (2011). Lifespan brain activity, β -amyloid, and Alzheimer's disease. *Trends in Cognitive Sciences*, 15(11), 520–6.
<http://doi.org/10.1016/j.tics.2011.09.004>
- Jaworska, N., MacMaster, F. P., Foster, J., & Ramasubbu, R. (2016). The influence of 5-HTTLPR and Val66Met polymorphisms on cortical thickness and volume in limbic and paralimbic regions in depression: a preliminary study. *BMC Psychiatry*, 16(1), 61. <http://doi.org/10.1186/s12888-016-0777-x>
- Jensen, A. (2013). Relationship between BDNF genotype, hippocampus volume, and anxiety, 1–32.
- Jiao, S.-S., Shen, L.-L., Zhu, C., Bu, X.-L., Liu, Y.-H., Liu, C.-H., ... Wang, Y.-J. (2016). Brain-derived neurotrophic factor protects against tau-related neurodegeneration of Alzheimer's disease. *Translational Psychiatry*, 6(10), e907.
<http://doi.org/10.1038/tp.2016.186>
- Jiménez-Pavón, D., Ortega, F. B., Ruiz, J. R., Chillón, P., Castillo, R., Artero, E. G., ... Gonzalez-Gross, M. (2010). Influence of socioeconomic factors on fitness and fatness in Spanish adolescents: The AVENA study. *International Journal of Pediatric Obesity*, 5(6), 467–473. <http://doi.org/10.3109/17477160903576093>
- Jochem, C., Baumeister, S. E., Wittfeld, K., Leitzmann, M. F., Bahls, M., Schminke, U., ... Jörgen Grabe, H. (2017). Domains of physical activity and brain volumes: A population-based study. *NeuroImage*, 156(May), 101–108.
<http://doi.org/10.1016/j.neuroimage.2017.05.020>
- Joffe, H. (2012). Thematic Analysis. In *Qualitative Research Methods in Mental Health and Psychotherapy: A Guide for Students and Practitioners (First Edition)* (pp. 210–223).
- Johnson, R., & Onwuegbuzie, A. J. (2004). Mixed Methods Research: A Research Paradigm Whose Time Has Come. *Educational Researcher*. American Educational Research Association. <http://doi.org/10.2307/3700093>

- Johnson, V. E., Stewart, W., & Smith, D. H. (2010). Traumatic brain injury and amyloid β pathology : a link to Alzheimer ' s disease ?, *11*(mAy), 361–370.
- Jonkman, L. (2006). The development of preparation, conflict monitoring and inhibition from early childhood to young adulthood; a Go/Nogo ERP study. *Brain Research*, *1097*(1), 181–193. <http://doi.org/10.1016/J.BRAINRES.2006.04.064>
- Kanai, R., Bahrami, B., Roylance, R., & Rees, G. (2012). Online social network size is reflected in human brain structure. *Proceedings. Biological Sciences*, *279*(1732), 1327–34. <http://doi.org/10.1098/rspb.2011.1959>
- Katz, M. J., Derby, C. A., Wang, C., Sliwinski, M. J., Ezzati, A., Zimmerman, M. E., ... Lipton, R. B. (2016). Influence of Perceived Stress on Incident Amnesic Mild Cognitive Impairment. *Alzheimer Disease & Associated Disorders*, *30*(2), 93–98. <http://doi.org/10.1097/WAD.0000000000000125>
- Kearney, M. H. (2001). Levels and applications of qualitative research evidence. *Research in Nursing & Health*, *24*(2), 145–153. <http://doi.org/10.1002/nur.1017>
- Kennedy, D. N., Makris, N., Herbert, M. R., Takahashi, T., & Jr, V. S. C. (2002). Basic principles of MRI and morphometry studies of human brain development, *3*, 268–278.
- Kerr, Z. Y., Register-Mihalik, J. K., Marshall, S. W., Evenson, K. R., Mihalik, J. P., & Guskiewicz, K. M. (2014). Disclosure and non-disclosure of concussion and concussion symptoms in athletes: Review and application of the socio-ecological framework. *Brain Injury : [BI]*, *9052*(April), 1–13. <http://doi.org/10.3109/02699052.2014.904049>
- Killgore, W. D. S., Olson, E. A., & Weber, M. (2013). Physical exercise habits correlate with gray matter volume of the hippocampus in healthy adult humans. *Scientific Reports*, *3*, 1–6. <http://doi.org/10.1038/srep03457>
- Kim, A., Fagan, A. M., Goate, A. M., Head, D., Sciences, B., & Disease, A. (2016). Lack of an association of BDNF Val66Met polymorphism and plasma BDNF with hippocampal volume and memory, *15*(3), 625–643. <http://doi.org/10.3758/s13415-015-0343-x.Lack>
- Kim, J.-M., Stewart, R., Bae, K.-Y., Kim, S.-W., Yang, S.-J., Park, K.-H., ... Yoon, J.-S. (2011). Role of BDNF val66met polymorphism on the association between physical activity and incident dementia. *Neurobiology of Aging*, *32*(3), 551.e5-551.e12. <http://doi.org/10.1016/j.neurobiolaging.2010.01.018>
- Kim, S.-N., Kang, D.-H., Yun, J.-Y., Lee, T.-Y., Jung, W.-H., Jang, J.-H., & Kwon, J.-S. (2013). Impact of the BDNF Val66Met Polymorphism on Regional Brain Gray Matter Volumes: Relevance to the Stress Response. *Psychiatry Investigation*, *10*(2), 173. <http://doi.org/10.4306/pi.2013.10.2.173>
- Koch, W., Teipel, S., Mueller, S., Benninghoff, J., Wagner, M., Bokde, A. L. W., ... Meindl, T. (2012). Diagnostic power of default mode network resting state fMRI in the detection of Alzheimer's disease. *Neurobiology of Aging*, *33*(3), 466–478. <http://doi.org/10.1016/j.neurobiolaging.2010.04.013>
- Kontos, A. P., Braithwaite, R., Chrisman, S. P. D., McAllister-Deitrick, J., Symington, L.,

- Reeves, V. L., & Collins, M. W. (2017). Systematic review and meta-analysis of the effects of football heading. *British Journal of Sports Medicine*, *51*(15), 1118–1124. <http://doi.org/10.1136/bjsports-2016-096276>
- Kroshus, E., Baugh, C. M., Daneshvar, D. H., & Viswanath, K. (2014). Understanding concussion reporting using a model based on the theory of planned behavior. *The Journal of Adolescent Health : Official Publication of the Society for Adolescent Medicine*, *54*(3), 269–274.e2. <http://doi.org/10.1016/j.jadohealth.2013.11.011>
- Kroshus, E., Daneshvar, D. H., Baugh, C. M., Nowinski, C. J., & Cantu, R. C. (2014). NCAA concussion education in ice hockey: an ineffective mandate. *British Journal of Sports Medicine*, *48*(2), 135–40. <http://doi.org/10.1136/bjsports-2013-092498>
- Kroshus, E., Garnett, B., Hawrilenko, M., Baugh, C. M., & Calzo, J. P. (2015). Concussion under-reporting and pressure from coaches, teammates, fans, and parents. *Social Science and Medicine*, *134*, 66–75. <http://doi.org/10.1016/j.socscimed.2015.04.011>
- Kuiper, J. S., Zuidersma, M., Oude Voshaar, R. C., Zuidema, S. U., van den Heuvel, E. R., Stolk, R. P., & Smidt, N. (2015). Social relationships and risk of dementia: A systematic review and meta-analysis of longitudinal cohort studies. *Ageing Research Reviews*, *22*, 39–57. <http://doi.org/10.1016/j.arr.2015.04.006>
- Lamb, Y. N., McKay, N. S., Thompson, C. S., Hamm, J. P., Waldie, K. E., & Kirk, I. J. (2015). Brain-derived neurotrophic factor Val66Met polymorphism, human memory, and synaptic neuroplasticity. *Wiley Interdisciplinary Reviews: Cognitive Science*, *6*(2), 97–108. <http://doi.org/10.1002/wcs.1334>
- Lancaster, T. M., Foley, S., Tansey, K. E., Linden, D. E. J., & Caseras, X. (2016). CACNA1C risk variant is associated with increased amygdala volume. *European Archives of Psychiatry and Clinical Neuroscience*, *266*(3), 269–275. <http://doi.org/10.1007/s00406-015-0609-x>
- Lang, E. W., Tomé, a M., Keck, I. R., Górriz-Sáez, J. M., & Puntonet, C. G. (2012). Brain connectivity analysis: a short survey. *Computational Intelligence and Neuroscience*, *2012*(iii), 412512. <http://doi.org/10.1155/2012/412512>
- Lang, U., Hellweg, R., Sander, T., & Gallinat, J. (2009). The Met allele of the BDNF Val66Met polymorphism is associated with increased BDNF serum concentrations. *Molecular Psychiatry*, *14*(2), 120–122. <http://doi.org/10.1038/mp.2008.80>
- Larson-Dupuis, C., Chamard, É., Falardeau, V., Frasnelli, J., Beaulieu, C., Poirier, J., ... De Beaumont, L. (2015). Impact of BDNF Val66Met polymorphism on olfactory functions of female concussed athletes. *Brain Injury*, *29*(7–8), 963–970. <http://doi.org/10.3109/02699052.2015.1016452>
- Laurent, S., Ejtehadi, M. R., Rezaei, M., Kehoe, P. G., & Mahmoudi, M. (2012). Interdisciplinary challenges and promising theranostic effects of nanoscience in Alzheimer's disease. *RSC Advances*, *2*(12), 5008. <http://doi.org/10.1039/c2ra01374f>
- Lee, S. J., Baek, J.-H., & Kim, Y.-H. (2015). Brain-derived Neurotrophic Factor Is Associated with Cognitive Impairment in Elderly Korean Individuals. *Clinical*

Psychopharmacology and Neuroscience, 13(3), 283–287.

<http://doi.org/10.9758/cpn.2015.13.3.283>

- Legge, R. M., Sendi, S., Cole, J. H., Cohen-Woods, S., Costafreda, S. G., Simmons, A., ... Fu, C. H. Y. (2015). Modulatory effects of brain-derived neurotrophic factor Val66Met polymorphism on prefrontal regions in major depressive disorder. *The British Journal of Psychiatry*, 206(5), 379–384. <http://doi.org/10.1192/bjp.bp.113.143529>
- Lehmann, M., Rohrer, J. D., Clarkson, M. J., Ridgway, G. R., Scahill, R. I., Modat, M., ... Fox, N. C. (2010). Reduced cortical thickness in the posterior cingulate gyrus is characteristic of both typical and atypical Alzheimer's disease. *Journal of Alzheimer's Disease : JAD*, 20(2), 587–98. <http://doi.org/10.3233/JAD-2010-1401>
- Lerch, J. P., Van Der Kouwe, A. J. W., Raznahan, A., Paus, T., Johansen-Berg, H., Miller, K. L., ... Sotiropoulos, S. N. (2017). Studying neuroanatomy using MRI. *Nature Neuroscience*, 20(3), 314–326. <http://doi.org/10.1038/nn.4501>
- Leventhal, H., Leventhal, E. A., & Breland, J. Y. (2011). Cognitive Science Speaks to the “Common-Sense” of Chronic Illness Management. *Annals of Behavioral Medicine*, 41(2), 152–163. <http://doi.org/10.1007/s12160-010-9246-9>
- Li, G.-D., Bi, R., Zhang, D.-F., Xu, M., Luo, R., Wang, D., ... Yao, Y.-G. (2017). Female-specific effect of the BDNF gene on Alzheimer's disease. *Neurobiology of Aging*. <http://doi.org/10.1016/j.neurobiolaging.2016.12.023>
- Li, Y., Li, Y., Li, X., Zhang, S., Zhao, J., Zhu, X., & Tian, G. (2017). Head injury as a risk factor for dementia and Alzheimer's disease: A systematic review and meta-analysis of 32 observational studies. *PLoS ONE*, 12(1). <http://doi.org/10.1371/journal.pone.0169650>
- Lim, Y. Y., Villemagne, V. L., Laws, S. M., Ames, D., Pietrzak, R. H., Ellis, K. A., ... AIBL Research Group. (2014). Effect of BDNF Val66Met on Memory Decline and Hippocampal Atrophy in Prodromal Alzheimer's Disease: A Preliminary Study. *PLoS ONE*, 9(1), e86498. <http://doi.org/10.1371/journal.pone.0086498>
- Liu, C.-C., Kanekiyo, T., Xu, H., Bu, G., & Bu, G. (2013). Apolipoprotein E and Alzheimer disease: risk, mechanisms and therapy. *Nature Reviews Neurology*, 9(2), 106–118. <http://doi.org/10.1038/nrneuro.2012.263>
- Lockhart, S., DeCarli, C., & Fama, R. (2014). Neuroimaging of the Aging Brain: Introduction to the Special Issue of Neuropsychology Review. *Neuropsychology Review*, 24(3), 267–270. <http://doi.org/10.1007/s11065-014-9269-2>
- Mackenzie, J. a, & McMillan, T. M. (2005). Knowledge of post-concussional syndrome in naïve lay-people, general practitioners and people with minor traumatic brain injury. *The British Journal of Clinical Psychology / the British Psychological Society*, 44(Pt 3), 417–24. <http://doi.org/10.1348/014466505X35696>
- Macpherson, H., Teo, W.-P., Schneider, L. A., & Smith, A. E. (2017). A Life-Long Approach to Physical Activity for Brain Health. *Frontiers in Aging Neuroscience*, 9, 147. <http://doi.org/10.3389/fnagi.2017.00147>
- Madill, A., & Gough, B. (2008). Qualitative Research and Its Place in Psychological

Science. <http://doi.org/10.1037/a0013220>

- Maguire, E. A., Gadian, D. G., Johnsrude, I. S., Good, C. D., Ashburner, J., Frackowiak, R. S. J., & Frith, C. D. (2000). Navigation-related structural change in the hippocampi of taxi drivers. *Proceedings of the National Academy of Sciences*, *97*(8), 4398–4403. <http://doi.org/10.1073/pnas.070039597>
- Mannings, C., Kalynych, C., Joseph, M. M., Smotherman, C., & Kraemer, D. F. (2014). recreational tackle football, *77*(3), 18–22. <http://doi.org/10.1097/TA.0000000000000371>
- Marshall, C. M. (2012). Sports-related concussion: A narrative review of the literature. *The Journal of the Canadian Chiropractic Association*, *56*(4), 299–310.
- Marshall, S., Bayley, M., McCullagh, S., Velikonja, D., & Berrigan, L. (2012). Clinical practice guidelines for mild traumatic brain injury and persistent symptoms. *Canadian Family Physician Médecin de Famille Canadien*, *58*(3), 257–67, e128-40.
- Mata, J., Thompson, R. J., & Gotlib, I. H. (2010). BDNF genotype moderates the relation between physical activity and depressive symptoms. *Health Psychology*, *29*(2), 130–133. <http://doi.org/10.1037/a0017261>
- Mather, K. A., Armstrong, N. J., Wen, W., Kwok, J. B., Assareh, A. A., Thalamuthu, A., ... Sachdev, P. S. (2015). Investigating the Genetics of Hippocampal Volume in Older Adults without Dementia. *PLOS ONE*, *10*(1), e0116920. <http://doi.org/10.1371/journal.pone.0116920>
- McBeath, J. . (2000). Labeling of Postconcussion Patients as Malingering and Litigious: A Common Practice in Need of Criticism.
- McCartney, M. (2015). Margaret McCartney: Direct to consumer genetic testing-is all knowledge power? *BMJ (Clinical Research Ed.)*, *350*, h439. <http://doi.org/10.1136/BMJ.H439>
- McEwen, B. S., Nasca, C., & Gray, J. D. (2016). Stress Effects on Neuronal Structure: Hippocampus, Amygdala, and Prefrontal Cortex. *Neuropsychopharmacology*, *41*(1), 3–23. <http://doi.org/10.1038/npp.2015.171>
- McGlashan, A. J., & Finch, C. F. (2010). The extent to which behavioural and social sciences theories and models are used in sport injury prevention research. *Sports Medicine (Auckland, N.Z.)*, *40*(10), 841–58. <http://doi.org/10.2165/11534960-000000000-00000>
- McKee, A. C., Stein, T. D., Nowinski, C. J., Stern, R. a, Daneshvar, D. H., Alvarez, V. E., ... Cantu, R. C. (2013). The spectrum of disease in chronic traumatic encephalopathy. *Brain : A Journal of Neurology*, *136*(Pt 1), 43–64. <http://doi.org/10.1093/brain/aws307>
- McKinlay, a, Bishop, a, & McLellan, T. (2011). Public knowledge of “concussion” and the different terminology used to communicate about mild traumatic brain injury (MTBI). *Brain Injury : [BI]*, *25*(7–8), 761–6. <http://doi.org/10.3109/02699052.2011.579935>
- Meiser, B., & Dunn, S. (2000). Psychological impact of genetic testing for Huntington’s disease: an update of the literature. *Journal of Neurology, Neurosurgery, and*

Psychiatry, 69(5), 574–8. <http://doi.org/10.1136/JNNP.69.5.574>

- Mesulam, M. (1999). Neuroplasticity failure in Alzheimer's disease: bridging the gap between plaques and tangles. *Neuron*, 24(3), 521–9.
- Mesulam, M.-M. (1990). Large-scale neurocognitive networks and distributed processing for attention, language, and memory. *Annals of Neurology*, 28(5), 597–613. <http://doi.org/10.1002/ana.410280502>
- Miles, L., Grossman, R. I., Johnson, G., Babb, J. S., Diller, L., & Inglese, M. (2008). Short-term DTI predictors of cognitive dysfunction in mild traumatic brain injury. *Brain Injury : [BI]*, 22(2), 115–22. <http://doi.org/10.1080/02699050801888816>
- Minelli, A., Zanardini, R., Bonvicini, C., Sartori, R., Pedrini, L., Gennarelli, M., & Bocchio-Chiavetto, L. (2011). BDNF serum levels, but not BDNF Val66Met genotype, are correlated with personality traits in healthy subjects. *European Archives of Psychiatry and Clinical Neuroscience*, 261(5), 323–329. <http://doi.org/10.1007/s00406-011-0189-3>
- Mok, V. C. T., Lam, B. Y. K., Wong, A., Ko, H., Markus, H. S., & Wong, L. K. S. (2017). Early-onset and delayed-onset poststroke dementia — revisiting the mechanisms. *Nature Reviews Neurology*. <http://doi.org/10.1038/nrneurol.2017.16>
- Monette, M. (2012). Heavy hitting: concussions and the courts. *CMAJ : Canadian Medical Association Journal = Journal de l'Association Medicale Canadienne*, 184(12), E639-40. <http://doi.org/10.1503/cmaj.109-4243>
- Montag, C., Weber, B., Fliessbach, K., Elger, C., & Reuter, M. (2009). The BDNF Val66Met polymorphism impacts parahippocampal and amygdala volume in healthy humans: incremental support for a genetic risk factor for depression. *Psychological Medicine*, 39(11), 1831. <http://doi.org/10.1017/S0033291709005509>
- Monti, J. M., Voss, M. W., Pence, A., McAuley, E., Kramer, A. F., & Cohen, N. J. (2013). History of mild traumatic brain injury is associated with deficits in relational memory, reduced hippocampal volume, and less neural activity later in life. *Frontiers in Aging Neuroscience*, 5, 41. <http://doi.org/10.3389/fnagi.2013.00041>
- Morgan, D. L. (1998). Practical Strategies for Combining Qualitative and Quantitative Methods: Applications to Health Research. *Qualitative Health Research*. <http://doi.org/10.1177/104973239800800307>
- Moshe Bar,* Elissa Aminoff, Malia Mason, and M. F. (2007). The Units Of Thought Moshe. *Hippocampus*, 17(9), 801–812. <http://doi.org/10.1002/hipo>
- Mulhern, S., & McMillan, T. M. (2006). Knowledge and expectation of postconcussion symptoms in the general population. *Journal of Psychosomatic Research*, 61(4), 439–45. <http://doi.org/10.1016/j.jpsychores.2006.03.004>
- Murphy, A. M., Askew, K. L., & Sumner, K. E. (2017). Parents' Intentions to Allow Youth Football Participation: Perceived Concussion Risk and the Theory of Planned Behavior. *Sport, Exercise, and Performance Psychology*, 6(3), 230–242. <http://doi.org/10.1037/SPY0000102>
- Murphy, G. (2017). Response to the consultation of the National Assembly for Wales'

Children, Young People and Education Committee on the First 1000 Days.

- Murray, E. A., Wise, S. P., & Graham, K. S. (2016). *The Evolution of Memory Systems*. Oxford University Press.
<http://doi.org/10.1093/acprof:oso/9780199686438.001.0001>
- Mychasiuk, R., Hehar, H., Ma, I., Candy, S., & Esser, M. J. (2016). Reducing the time interval between concussion and voluntary exercise restores motor impairment, short-term memory, and alterations to gene expression. *European Journal of Neuroscience*, *44*(7), 2407–2417. <http://doi.org/10.1111/ejn.13360>
- NHS Digital. (2017). Statistics on Obesity, Physical Activity and Diet - England, 2017. Retrieved from <http://digital.nhs.uk/catalogue/PUB23742>
- Nicole, L., Jessica, D., Mary, S., & Dianne, N.-S. (2014). Adolescent Consumption of Sports and Energy Drinks: Linkages to Higher Physical Activity, Unhealthy Beverage Patterns, Cigarette Smoking, and Screen Media Use. *Journal of Nutrition Education and Behavior*, *46*(3), 181–187.
<http://doi.org/10.1016/J.JNEB.2014.02.008>
- Niogi, S. N., Mukherjee, P., Ghajar, J., Johnson, C., Kolster, R. a, Sarkar, R., ... McCandliss, B. D. (2008). Extent of microstructural white matter injury in postconcussive syndrome correlates with impaired cognitive reaction time: a 3T diffusion tensor imaging study of mild traumatic brain injury. *AJNR. American Journal of Neuroradiology*, *29*(5), 967–73. <http://doi.org/10.3174/ajnr.A0970>
- Notaras, M., Hill, R., & Buuse, M. Van Den. (2015). The BDNF gene Val66Met polymorphism as a modifier of psychiatric disorder susceptibility : progress and controversy, (February), 1–15. <http://doi.org/10.1038/mp.2015.27>
- Notaras, M., Hill, R., & van den Buuse, M. (2015). The BDNF gene Val66Met polymorphism as a modifier of psychiatric disorder susceptibility: progress and controversy. *Molecular Psychiatry*, *20*(8), 916–930.
<http://doi.org/10.1038/mp.2015.27>
- O’Dwyer, L., Lamberton, F., Matura, S., Tanner, C., Scheibe, M., Miller, J., ... Hampel, H. (2012). Reduced Hippocampal Volume in Healthy Young ApoE4 Carriers: An MRI Study. *PLoS ONE*, *7*(11), e48895. <http://doi.org/10.1371/journal.pone.0048895>
- Opendak, M., & Gould, E. (2015). Adult neurogenesis: a substrate for experience-dependent change. *Trends in Cognitive Sciences*, *19*(3), 151–161.
<http://doi.org/10.1016/j.tics.2015.01.001>
- Ortega, F. B., Campos, D., Cadenas-Sanchez, C., Altmäe, S., Martínez-Zaldívar, C., Martín-Matillas, M., ... Campoy, C. (2017). Physical fitness and shapes of subcortical brain structures in children. *British Journal of Nutrition*, (May), 1–10.
<http://doi.org/10.1017/S0007114516001239>
- Pajonk, F.-G., Wobrock, T., Gruber, O., Scherk, H., Berner, D., Kaizl, I., ... Falkai, P. (2010). Hippocampal Plasticity in Response to Exercise in Schizophrenia. *Archives of General Psychiatry*, *67*(2), 133.
<http://doi.org/10.1001/archgenpsychiatry.2009.193>
- Palombo, D. J., Bacopulos, A., Amaral, R. S. C., Olsen, R. K., Todd, R. M., Anderson, A.

- K., & Levine, B. (2018). Episodic autobiographical memory is associated with variation in the size of hippocampal subregions. *Hippocampus*, 28(2), 69–75. <http://doi.org/10.1002/hipo.22818>
- Palombo, D. J., Williams, L. J., Abdi, H., & Levine, B. (2013). The survey of autobiographical memory (SAM): A novel measure of trait mnemonics in everyday life. *Cortex*, 49(6), 1526–1540. <http://doi.org/10.1016/j.cortex.2012.08.023>
- Park, D. C., & Festini, S. B. (2016). Theories of Memory and Aging: A Look at the Past and a Glimpse of the Future. *The Journals of Gerontology. Series B, Psychological Sciences and Social Sciences*, 72(1), gbw066. <http://doi.org/10.1093/geronb/gbw066>
- Pasaniuc, B., & Price, A. L. (2017). Dissecting the genetics of complex traits using summary association statistics. *Nature Reviews Genetics*, 18(2), 117–127. <http://doi.org/10.1038/nrg.2016.142>
- Patricios, J. S., & Kemp, S. (2013). Chronic traumatic encephalopathy: Rugby's call for clarity, data and leadership in the concussion debate. *British Journal of Sports Medicine*. <http://doi.org/10.1136/bjsports-2013-093031>
- Perez-Polo, J. R., Rea, H. C., Johnson, K. M., Parsley, M. a, Unabia, G. C., Xu, G., ... Hulsebosch, C. E. (2013). Inflammatory consequences in a rodent model of mild traumatic brain injury. *Journal of Neurotrauma*, 30(9), 727–40. <http://doi.org/10.1089/neu.2012.2650>
- Perry, D. C., Sturm, V. E., Peterson, M. J., Pieper, C. F., Bullock, T., Boeve, B. F., ... Welsh-Bohmer, K. A. (2016). Traumatic brain injury is associated with subsequent neurologic and psychiatric disease: a meta-analysis HHS Public Access. *J Neurosurg*, 124(2), 511–526. <http://doi.org/10.3171/2015.2.JNS14503>
- Petkus, A. J., Reynolds, C. A., Wetherell, J. L., Kremen, W. S., Pedersen, N. L., & Gatz, M. (2016). Anxiety is associated with increased risk of dementia in older Swedish twins. *Alzheimer's and Dementia*, 12(4), 399–406. <http://doi.org/10.1016/j.jalz.2015.09.008>
- Petterson, J. (2002a). Does rugby headgear prevent concussion? Attitudes of Canadian players and coaches. *British Journal of Sports Medicine*, 36(1), 19–22.
- Petterson, J. a. (2002b). Does rugby headgear prevent concussion? Attitudes of Canadian players and coaches. *British Journal of Sports Medicine*, 36(1), 19–22.
- Pikkarainen, M., Rönkkö, S., Savander, V., Insausti, R., & Pitkänen, A. (1999). Projections from the lateral, basal, and accessory basal nuclei of the amygdala to the hippocampal formation in rat. *The Journal of Comparative Neurology*, 403(2), 229–60.
- Pluye, P., & Hong, Q. N. (2014). Combining the Power of Stories and the Power of Numbers: Mixed Methods Research and Mixed Studies Reviews. *Annual Review of Public Health*, 35(1), 29–45. <http://doi.org/10.1146/annurev-publhealth-032013-182440>
- Poldrack, R. A. (2015). Is “efficiency” a useful concept in cognitive neuroscience? *Developmental Cognitive Neuroscience*, 11, 12–17.

<http://doi.org/10.1016/J.DCN.2014.06.001>

- Prakash, R. S., Voss, M. W., Erickson, K. I., & Kramer, A. F. (2015). Physical Activity and Cognitive Vitality. *Annual Review of Psychology*, 66(1), 769–797.
<http://doi.org/10.1146/annurev-psych-010814-015249>
- Pratt, M. G. (2009). From the Editors: For the Lack of a Boilerplate: Tips on Writing Up (and Reviewing) Qualitative Research. *Academy of Management Journal*, 52(5), 856–862. <http://doi.org/10.5465/amj.2009.44632557>
- Quarrie, K. L., Brooks, J. H. M., Burger, N., Hume, P. A., & Jackson, S. (2017). Facts and values: On the acceptability of risks in children’s sport using the example of rugby—a narrative review. *British Journal of Sports Medicine*, 51(15), 1134–1139.
<http://doi.org/10.1136/bjsports-2017-098013>
- Raftery, M. (2014). Concussion and chronic traumatic encephalopathy: International Rugby Board’s response. *British Journal of Sports Medicine*, 48(2), 79–80.
<http://doi.org/10.1136/bjsports-2013-093051>
- Raslau, F. D., Mark, I. T., Klein, A. P., Ulmer, J. L., Mathews, V., & Mark, X. L. P. (2015). Memory Part 2 : The Role of the Medial Temporal Lobe, (May), 2–5.
<http://doi.org/10.3174/ajnr.A4371>
- Rawson, K. A., Gunstad, J., Hughes, J., Spitznagel, M. B., Potter, V., Waechter, D., & Rosneck, J. (2010). The METER: A brief, self-administered measure of health literacy. *Journal of General Internal Medicine*, 25(1), 67–71.
<http://doi.org/10.1007/s11606-009-1158-7>
- Register-Mihalik, J. K., Linnan, L. A., Marshall, S. W., McLeod, T. C. V., Mueller, F. O., & Guskiewicz, K. M. (2013). Using theory to understand high school aged athletes’ intentions to report sport-related concussion: Implications for concussion education initiatives.
- Register-Mihalik, J. K., Linnan, L. a, Marshall, S. W., Valovich McLeod, T. C., Mueller, F. O., & Guskiewicz, K. M. (2013). Using theory to understand high school aged athletes’ intentions to report sport-related concussion: Implications for concussion education initiatives. *Brain Injury : [BI]*, 27(7–8), 878–86.
<http://doi.org/10.3109/02699052.2013.775508>
- Reinvang, I., Deary, I. J., Fjell, A. M., Steen, V. M., Espeseth, T., & Parasuraman, R. (2010). Neurogenetic effects on cognition in aging brains: a window of opportunity for intervention? *Frontiers in Aging Neuroscience*, 2(November), 143.
<http://doi.org/10.3389/fnagi.2010.00143>
- Reinvang, I., Espeseth, T., & Westlye, L. T. (2013). APOE-related biomarker profiles in non-pathological aging and early phases of Alzheimer’s disease. *Neuroscience & Biobehavioral Reviews*, 37(8), 1322–1335.
<http://doi.org/10.1016/j.neubiorev.2013.05.006>
- Reiss, D., Eccles, J. S., & Nielsen, L. (2014). Conscientiousness and public health: Synthesizing current research to promote healthy aging. *Developmental Psychology*, 50(5), 1303–1314. <http://doi.org/10.1037/a0036473>
- Reuter-Lorenz, P. A., & Park, D. C. (2014). How Does it STAC Up? Revisiting the

- Scaffolding Theory of Aging and Cognition. *Neuropsychology Review*, 24(3), 355–370. <http://doi.org/10.1007/s11065-014-9270-9>
- Richards, L. (1999). *Using NVivo in Qualitative Research*. London and Los Angeles: Sage.
- Rieker, P. P., & Bird, C. E. (2005). Rethinking Gender Differences in Health: Why We Need to Integrate Social and Biological Perspectives. *The Journals of Gerontology: Series B*, 60(Special_Issue_2), S40–S47. http://doi.org/10.1093/geronb/60.Special_Issue_2.S40
- Risacher, S. L., & Saykin, A. J. (2013). Neuroimaging and other biomarkers for Alzheimer’s disease: the changing landscape of early detection. *Annual Review of Clinical Psychology*, 9(Mci), 621–48. <http://doi.org/10.1146/annurev-clinpsy-050212-185535>
- Ritchev, M., Libby, L. A., & Ranganath, C. (2015). *Cortico-hippocampal systems involved in memory and cognition: The PMAT framework*. *Progress in Brain Research* (1st ed., Vol. 219). Elsevier B.V. <http://doi.org/10.1016/bs.pbr.2015.04.001>
- Rivara, F. P., Schiff, M., Chrisman, S. P., Chung, S. K., Ellenbogen, R. G., & Herring, S. (2014). The effect of coach education on reporting of concussions among high school athletes after passage of a concussion law. *The American Journal of Sports Medicine*, 42(5), 1197–203. <http://doi.org/10.1177/0363546514521774>
- Rosenbaum, A. M., & Arnett, P. a. (2010). The development of a survey to examine knowledge about and attitudes toward concussion in high-school students. *Journal of Clinical and Experimental Neuropsychology*, 32(1), 44–55. <http://doi.org/10.1080/13803390902806535>
- Rosenstock, I. (1966). Why people use health services. *Milbank Memorial Fund Quarterly*, (44), 94–124.
- Rudman, L. A. (2014). Sources of Implicit Attitudes. *Current Directions in Psychological Science*, 13(2), 79–82.
- Rutter, M. (2006). Implications of resilience concepts for scientific understanding. *Annals of the New York Academy of Sciences*, 1094, 1–12. <http://doi.org/10.1196/annals.1376.002>
- Salvatore, J. E., Aliev, F., Bucholz, K., Agrawal, A., Hesselbrock, V., Hesselbrock, M., ... Dick, D. M. (2015). Polygenic Risk for Externalizing Disorders. *Clinical Psychological Science*, 3(2), 189–201. <http://doi.org/10.1177/2167702614534211>
- Sanderson, J., Weathers, M., Snedaker, K., & Gramlich, K. (2017). “I Was Able to Still Do My Job on the Field and Keep Playing”: An Investigation of Female and Male Athletes’ Experiences With (Not) Reporting Concussions. *Communication & Sport*, 5(3), 267–287. <http://doi.org/10.1177/2167479515623455>
- Sarmiento, K., Mitchko, J., Klein, C., & Wong, S. (2010). Evaluation of the Centers for Disease Control and Prevention’s concussion initiative for high school coaches: “Heads Up: Concussion in High School Sports”. *The Journal of School Health*, 80(3), 112–8. <http://doi.org/10.1111/j.1746-1561.2010.00491.x>
- Sawyer, R. J., Hamdallah, M., White, D., Pruzan, M., Mitchko, J., & Huitric, M. (2010). High school coaches’ assessments, intentions to use, and use of a concussion

prevention toolkit: Centers for Disease Control and Prevention's heads up: concussion in high school sports. *Health Promotion Practice*, 11(1), 34–43. <http://doi.org/10.1177/1524839907309377>

- Schoenberg, N. E., Amey, C. H., & Coward, R. T. (1998). Diabetes Knowledge and Sources of Information Among African American and White Older Women. *The Diabetes Educator*, 24(3), 319–324. <http://doi.org/10.1177/014572179802400306>
- Ségonne, F., Dale, A. M., Busa, E., Glessner, M., Salat, D., Hahn, H. K., & Fischl, B. (2004). A hybrid approach to the skull stripping problem in MRI. *NeuroImage*, 22(3), 1060–1075. <http://doi.org/10.1016/j.neuroimage.2004.03.032>
- Shaw, P., Lerch, J. P., Pruessner, J. C., Taylor, K. N., Rose, A. B., Greenstein, D., ... Giedd, J. N. (2007). Cortical morphology in children and adolescents with different apolipoprotein E gene polymorphisms: an observational study. *The Lancet Neurology*, 6(6), 494–500. [http://doi.org/10.1016/S1474-4422\(07\)70106-0](http://doi.org/10.1016/S1474-4422(07)70106-0)
- Shearer, A. (2017). Alan Shearer: Making my documentary Dementia, Football and Me. Retrieved from <http://www.bbc.co.uk/sport/football/41902953>
- Sheldon, S., Farb, N., Palombo, D. J., & Levine, B. (2016). Intrinsic medial temporal lobe connectivity relates to individual differences in episodic autobiographical remembering. *Cortex*, 74, 206–216. <http://doi.org/10.1016/j.cortex.2015.11.005>
- Shenton, M. E., Hamoda, H. M., Schneiderman, J. S., Bouix, S., Pasternak, O., Rathi, Y., ... Zafonte, R. (2012). A review of magnetic resonance imaging and diffusion tensor imaging findings in mild traumatic brain injury. *Brain Imaging and Behavior*, 6(2), 137–92. <http://doi.org/10.1007/s11682-012-9156-5>
- Sleiman, S. F., & Chao, M. V. (2015). Downstream Consequences of Exercise Through the Action of BDNF. *Brain Plasticity*, 1, 143–148. <http://doi.org/10.3233/BPL-150017>
- Smith, D. H., Johnson, V. E., & Stewart, W. (2013). Chronic neuropathologies of single and repetitive TBI: substrates of dementia? *Nature Reviews. Neurology*, 9(4), 211–21. <http://doi.org/10.1038/nrneurol.2013.29>
- Snell, D. L., Hay-Smith, E. J. C., Surgenor, L. J., & Siegert, R. J. (2013). Examination of outcome after mild traumatic brain injury: the contribution of injury beliefs and Leventhal's common sense model. *Neuropsychological Rehabilitation*, 23(3), 333–62. <http://doi.org/10.1080/09658211.2012.758419>
- Sport England. (2016). Active People Survey 2016. Retrieved from <https://www.sportengland.org/research/about-our-research/active-people-survey/>
- Stein, J. L., Medland, S. E., Vasquez, A. A., Hibar, D. P., Senstad, R. E., Winkler, A. M., ... Enhancing Neuro Imaging Genetics through Meta-Analysis Consortium. (2012). Identification of common variants associated with human hippocampal and intracranial volumes. *Nature Genetics*, 44(5), 552–561. <http://doi.org/10.1038/ng.2250>
- Stephen, R., Hongisto, K., Solomon, A., & Lönnroos, E. (2017). Physical Activity and Alzheimer's Disease: A Systematic Review. *The Journals of Gerontology Series A:*

Biological Sciences and Medical Sciences, 72(6), glw251.

<http://doi.org/10.1093/gerona/glw251>

- Sullivan, K. A., & Edmed, S. L. (2012a). An examination of the expected symptoms of postconcussion syndrome in a nonclinical sample. *The Journal of Head Trauma Rehabilitation*, 27(4), 293–301. <http://doi.org/10.1097/HTR.0b013e31822123ce>
- Sullivan, K. A., & Edmed, S. L. (2012b). Systematic variation of the severity of motor vehicle accident-related traumatic brain injury vignettes produces different post-concussion symptom reports. *The Clinical Neuropsychologist*, 26(8), 1255–77. <http://doi.org/10.1080/13854046.2012.735254>
- Sullivan, S. J., Schneiders, A. G., Cheang, C.-W., Kitto, E., Lee, H., Redhead, J., ... McCrory, P. R. (2012). “What”s happening?’ A content analysis of concussion-related traffic on Twitter. *British Journal of Sports Medicine*, 46(4), 258–63. <http://doi.org/10.1136/bjism.2010.080341>
- Sullivan, Bourne, L., Choie, S., Eastwood, B., Isbister, S., McCrory, P., & Gray, A. (2009). Understanding of sport concussion by the parents of young rugby players: a pilot study. *Clinical Journal of Sport Medicine : Official Journal of the Canadian Academy of Sport Medicine*, 19(3), 228–30. <http://doi.org/10.1097/JSM.0b013e3181a41e43>
- Sye, G., Sullivan, S. J., & McCrory, P. (2006). High school rugby players’ understanding of concussion and return to play guidelines. *British Journal of Sports Medicine*, 40(12), 1003–5. <http://doi.org/10.1136/bjism.2005.020511>
- Takahashi, T., Suzuki, M., Tsunoda, M., Kawamura, Y., Takahashi, N., Tsuneki, H., ... Ozaki, N. (2008). Association between the brain-derived neurotrophic factor Val66Met polymorphism and brain morphology in a Japanese sample of schizophrenia and healthy comparisons. *Neuroscience Letters*, 435(1), 34–39. <http://doi.org/10.1016/j.neulet.2008.02.004>
- Tate, D. F., & Bigler, E. D. (2000). Fornix and hippocampal atrophy in traumatic brain injury. *Learning & Memory (Cold Spring Harbor, N.Y.)*, 7(6), 442–6.
- Taylor, S. . (1999). *Health Psychology* (4th ed.). New York: McGraw-Hill.
- Thomas, A. G., Dennis, A., Bandettini, P. A., & Johansen-Berg, H. (2012). The effects of aerobic activity on brain structure. *Frontiers in Psychology*, 3(MAR), 1–9. <http://doi.org/10.3389/fpsyg.2012.00086>
- Thomas, A. G., Dennis, A., Rawlings, N. B., Stagg, C. J., Matthews, L., Morris, M., ... Johansen-Berg, H. (2016). Multi-modal characterization of rapid anterior hippocampal volume increase associated with aerobic exercise. *NeuroImage*, 131, 162–170. <http://doi.org/10.1016/j.neuroimage.2015.10.090>
- Torres, D. M., Galetta, K. M., Phillips, H. W., Dziemianowicz, E. M. S., Wilson, J. A., Dorman, E. S., ... Balcer, L. J. (2013). Sports-related concussion: Anonymous survey of a collegiate cohort. *Neurology. Clinical Practice*, 3(4), 279–287. <http://doi.org/10.1212/CPJ.0b013e3182a1ba22>
- Van der Linden, M., & Juillerat Van der Linden, A. C. (2016). A life-course and multifactorial approach to Alzheimer’s disease: Implications for research, clinical

- assessment and intervention practices. *Dementia (London)*, 0(0), 1–16.
<http://doi.org/10.1177/1471301216657270>
- Voets, N. L., Hodgetts, C. J., Sen, A., Adcock, J. E., & Emir, U. (2017). Hippocampal MRS and subfield volumetry at 7T detects dysfunction not specific to seizure focus. *Scientific Reports*, 7(1), 16138. <http://doi.org/10.1038/s41598-017-16046-5>
- Voineskos, A. N., Lerch, J. P., Felsky, D., Shaikh, S., Rajji, T. K., Miranda, D., ... Kennedy, J. L. (2011). The Brain-Derived Neurotrophic Factor Val66Met Polymorphism and Prediction of Neural Risk for Alzheimer Disease. *Archives of General Psychiatry*, 68(2), 198. <http://doi.org/10.1001/archgenpsychiatry.2010.194>
- Voss, M. W., Erickson, K. I., Prakash, R. S., Chaddock, L., Kim, J. S., Alves, H., ... Kramer, A. F. (2013). Neurobiological markers of exercise-related brain plasticity in older adults. *Brain, Behavior, and Immunity*, 28, 90–99.
<http://doi.org/10.1016/j.bbi.2012.10.021>
- Voss, M. W., Prakash, R. S., Erickson, K. I., Basak, C., Chaddock, L., Kim, J. S., ... Kramer, A. F. (2010). Plasticity of brain networks in a randomized intervention trial of exercise training in older adults. *Frontiers in Aging Neuroscience*, 2.
<http://doi.org/10.3389/fnagi.2010.00032>
- Walhovd, K. B., Fjell, A. M., & Espeseth, T. (2014). Cognitive decline and brain pathology in aging - need for a dimensional, lifespan and systems vulnerability view. *Scandinavian Journal of Psychology*, 55(3), 244–254.
<http://doi.org/10.1111/sjop.12120>
- Walhovd, K. B., Westerhausen, R., de Lange, A.-M. G., Bråthen, A. C. S., Grydeland, H., Engvig, A., & Fjell, A. M. (2015). Premises of plasticity — And the loneliness of the medial temporal lobe. *NeuroImage*.
<http://doi.org/10.1016/j.neuroimage.2015.10.060>
- Walhovd, K. B., Westerhausen, R., de Lange, A.-M. G., Brathen, A. C. S., Grydeland, H., Engvig, A., & Fjell Kristine B.; ORCID: <http://orcid.org/0000-0003-1918-1123>, A. M. A. I.-O. <http://orcid.org/Walhov>. (2016). Premises of plasticity-And the loneliness of the medial temporal lobe. *NeuroImage*, 131, 48–54.
<http://doi.org/http://dx.doi.org/10.1016/j.neuroimage.2015.10.060>
- Walter, F. M., Emery, J., Braithwaite, D., & Marteau, T. M. (2004). Lay understanding of familial risk of common chronic diseases: a systematic review and synthesis of qualitative research. *Annals of Family Medicine*, 2(6), 583–94.
<http://doi.org/10.1370/afm.242>
- Warburton, D. E. R., Nicol, C. W., & Bredin, S. S. D. (2006). Health benefits of physical activity: the evidence. *CMAJ : Canadian Medical Association Journal = Journal de l'Association Medicale Canadienne*, 174(6), 801–9.
<http://doi.org/10.1503/cmaj.051351>
- Ward, D. D., Summers, M. J., Saunders, N. L., Janssen, P., Stuart, K. E., & Vickers, J. C. (2014). APOE and BDNF Val66Met polymorphisms combine to influence episodic memory function in older adults. *Behavioural Brain Research*, 271, 309–315.
<http://doi.org/10.1016/j.bbr.2014.06.022>
- Weber, M., & Edwards, M. G. (2010). The effect of brain injury terminology on

- university athletes' expected outcome from injury, familiarity and actual symptom report. *Brain Injury : [BI]*, 24(11), 1364–71.
<http://doi.org/10.3109/02699052.2010.507110>
- Weber, M., & Edwards, M. G. (2012). Sport concussion knowledge in the UK general public. *Archives of Clinical Neuropsychology : The Official Journal of the National Academy of Neuropsychologists*, 27(3), 355–61.
<http://doi.org/10.1093/arclin/acs029>
- Welsh-Government. (2017). Flying Start. Retrived from
<http://gov.wales/topics/people-and-communities/people/children-and-young-people/parenting-support-guidance/help/flyingstart/?lang=en>.
- Westman, E., Aguilar, C., Muehlboeck, J. S., & Simmons, A. (2013). Regional magnetic resonance imaging measures for multivariate analysis in Alzheimer's disease and mild cognitive impairment. *Brain Topography*, 26(1), 9–23.
<http://doi.org/10.1007/s10548-012-0246-x>
- Whittaker, R., Kemp, S., & House, A. (2007). Illness perceptions and outcome in mild head injury: a longitudinal study. *Journal of Neurology, Neurosurgery, and Psychiatry*, 78(6), 644–6. <http://doi.org/10.1136/jnnp.2006.101105>
- Wightwick, A. (2017). School pupils are being given vouchers to spend on activities in a bid to create healthy teens. Retrieved January 31, 2018, from
<https://www.walesonline.co.uk/news/wales-news/school-pupils-being-given-vouchers-12431350>
- Williams, D. H., Levin, H. S., & Eisenberg, H. M. (1990). Mild head injury classification. *Neurosurgery*, 27(3), 422–8.
- Williams, J., Langdon, J. L., McMillan, J. L., & Buckley, T. A. (2016). English professional football players concussion knowledge and attitude. *Journal of Sport and Health Science*, 5(2), 197–204. <http://doi.org/10.1016/j.jshs.2015.01.009>
- Winter, B., Breitenstein, C., Mooren, F. C., Voelker, K., Fobker, M., Lechtermann, A., ... Knecht, S. (2007). High impact running improves learning. *Neurobiology of Learning and Memory*, 87(4), 597–609. <http://doi.org/10.1016/j.nlm.2006.11.003>
- Wisse, L. E. M., Kuijf, H. J., Honingh, A. M., Wang, H., Pluta, J. B., Das, S. R., ... Geerlings, M. I. (2016). Automated Hippocampal Subfield Segmentation at 7T MRI. *American Journal of Neuroradiology*, 37(6), 1050–1057. <http://doi.org/10.3174/ajnr.A4659>
- Wood, R. . (2004). Understanding the “miserable minority”: a diathesis-stress paradigm for post-concussional syndrome. *Brain Injury : [BI]*, 18(11), 1135–53.
<http://doi.org/10.1080/02699050410001675906>
- Wood, R. . (2007). Post concussional syndrome: all in the minds eye! *Journal of Neurology, Neurosurgery, and Psychiatry*, 78(6), 552.
<http://doi.org/10.1136/jnnp.2006.113845>
- Zemek, R., Maps, K. E., Moreau, K., Farion, K. J., Solomon, B., Bscn, R. N., ... Moreau, K. (2014). front-line primary care providers, 19(9), 475–480.
- Zhang, W., & Watanabe-Galloway, S. (2014). Using Mixed Methods Effectively in Prevention Science: Designs, Procedures, and Examples. *Prevention Science*, 15(5),

654–662. <http://doi.org/10.1007/s11121-013-0415-5>

Zhao, X. (2014). Relationships Between Sources of Health Information and Diabetes Knowledge in the U.S. Hispanic Population. *Health Communication, 29*(6), 574–585. <http://doi.org/10.1080/10410236.2013.784937>

Zuckerman, M. (1983). Sensation seeking and sports. *Personality and Individual Differences, 4*(3), 285–292. [http://doi.org/10.1016/0191-8869\(83\)90150-2](http://doi.org/10.1016/0191-8869(83)90150-2)

Appendices

APPENDIX A: SPSS PROCESS: Model 1 diagram

Model Templates for PROCESS for SPSS and SAS C 2013-2015 Andrew F. Hayes and The Guilford Press

Model 1

Conceptual Diagram

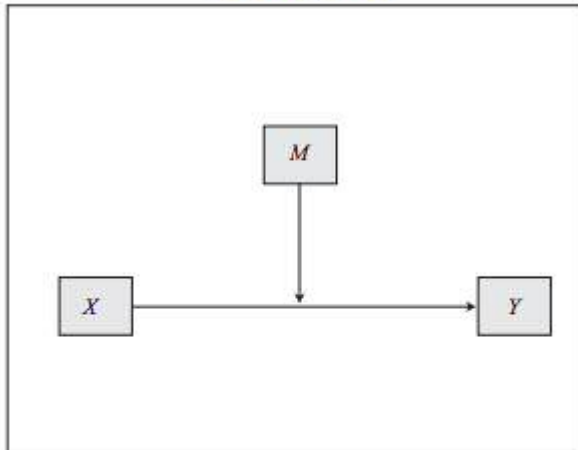

Statistical Diagram

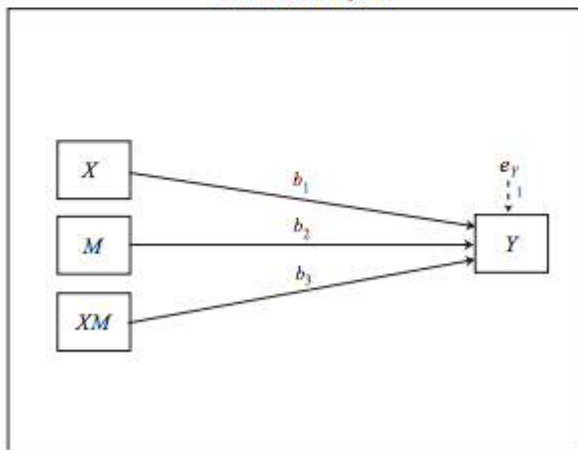

Conditional effect of X on $Y = b_1 + b_3M$

Source: <http://afhayes.com/public/templates.pdf>

APPENDIX B: GPAQ Questionnaire (source: World Health Organisation, http://www.who.int/ncds/surveillance/steps/GPAQ_EN.pdf)

Physical Activity			
<p>Next I am going to ask you about the time you spend doing different types of physical activity in a typical week. Please answer these questions even if you do not consider yourself to be a physically active person.</p> <p>Think first about the time you spend doing work. Think of work as the things that you have to do such as paid or unpaid work, study/training, household chores, harvesting food/crops, fishing or hunting for food, seeking employment. [Insert other examples if needed]. In answering the following questions 'vigorous-intensity activities' are activities that require hard physical effort and cause large increases in breathing or heart rate, 'moderate-intensity activities' are activities that require moderate physical effort and cause small increases in breathing or heart rate.</p>			
Questions	Response	Code	
Activity at work			
1	Does your work involve vigorous-intensity activity that causes large increases in breathing or heart rate like [carrying or lifting heavy loads, digging or construction work] for at least 10 minutes continuously? [INSERT EXAMPLES] (USE SHOWCARD)	Yes 1 No 2 If No, go to P 4	P1
2	In a typical week, on how many days do you do vigorous-intensity activities as part of your work?	Number of days []	P2
3	How much time do you spend doing vigorous-intensity activities at work on a typical day?	Hours : minutes [] : [] hrs mins	P3 (a-b)
4	Does your work involve moderate-intensity activity that causes small increases in breathing or heart rate such as brisk walking [or carrying light loads] for at least 10 minutes continuously? [INSERT EXAMPLES] (USE SHOWCARD)	Yes 1 No 2 If No, go to P 7	P4
5	In a typical week, on how many days do you do moderate-intensity activities as part of your work?	Number of days []	P5
6	How much time do you spend doing moderate-intensity activities at work on a typical day?	Hours : minutes [] : [] hrs mins	P6 (a-b)
Travel to and from places			
<p>The next questions exclude the physical activities at work that you have already mentioned. Now I would like to ask you about the usual way you travel to and from places. For example to work, for shopping, to market, to place of worship. [insert other examples if needed]</p>			
7	Do you walk or use a bicycle (pedal cycle) for at least 10 minutes continuously to get to and from places?	Yes 1 No 2 If No, go to P 10	P7
8	In a typical week, on how many days do you walk or bicycle for at least 10 minutes continuously to get to and from places?	Number of days []	P8
9	How much time do you spend walking or bicycling for travel on a typical day?	Hours : minutes [] : [] hrs mins	P9 (a-b)
Recreational activities			
<p>The next questions exclude the work and transport activities that you have already mentioned. Now I would like to ask you about sports, fitness and recreational activities (leisure). [insert relevant terms]</p>			
10	Do you do any vigorous-intensity sports, fitness or recreational (leisure) activities that cause large increases in breathing or heart rate like [running or football] for at least 10 minutes continuously? [INSERT EXAMPLES] (USE SHOWCARD)	Yes 1 No 2 If No, go to P 13	P10
11	In a typical week, on how many days do you do vigorous-intensity sports, fitness or recreational (leisure) activities?	Number of days []	P11
12	How much time do you spend doing vigorous-intensity sports, fitness or recreational activities on a typical day?	Hours : minutes [] : [] hrs mins	P12 (a-b)

Continued on next page

2

Physical Activity (recreational activities) contd.			
Questions	Response	Code	
13	Do you do any moderate-intensity sports, fitness or recreational (leisure) activities that causes a small increase in breathing or heart rate such as brisk walking, cycling, swimming, volleyball for at least 10 minutes continuously? [INSERT EXAMPLES] (USE SHOWCARD)	Yes 1 No 2 If No, go to P16	P13
14	In a typical week, on how many days do you do moderate-intensity sports, fitness or recreational (leisure) activities?	Number of days []	P14
15	How much time do you spend doing moderate-intensity sports, fitness or recreational (leisure) activities on a typical day?	Hours : minutes [] : [] hrs mins	P15 (a-b)
Sedentary behaviour			
<p>The following question is about sitting or reclining at work, at home, getting to and from places, or with friends including time spent [sitting at a desk, sitting with friends, travelling in car, bus, train, reading, playing cards or watching television], but do not include time spent sleeping. [INSERT EXAMPLES] (USE SHOWCARD)</p>			
16	How much time do you usually spend sitting or reclining on a typical day?	Hours : minutes [] : [] hrs mins	P16 (a-b)

APPENDIX C: Alphabetical Table of Included Studies

Reference	Method	Key Findings	Topic
Baker, J. F., Devitt, B. M., Green, J., & McCarthy, C. (2013). Concussion among under 20 rugby union players in Ireland: incidence, attitudes and knowledge. <i>Irish journal of medical science</i> , 182(1), 121–5.	Survey of under-20 male rugby union players on history of concussion, attitudes and behaviours.	Moderate levels of reporting concussion (low to coach) despite high safety attitudes towards concussion compared to other injuries. Moderate level of belief in long-term consequences and calls for further educational initiatives due to poor knowledge.	Management
Braham, R., Finch, C. F., McIntosh, & McCrory, P. (2004). Community football players' attitudes towards protective equipment--a pre-season measure. <i>British journal of sports medicine</i> , 38(4), 426–30.	Survey pre-season Australian footballers on attitudes towards headgear and mouthguards.	High use and safe attitudes towards use of mouthguards but low use of headgear.	Prevention
Chrisman, S. P., Quitiquit, C., & Rivara, F. P. (2013). Qualitative study of barriers to concussive symptom reporting in high school athletics. <i>The Journal of adolescent health : official publication of the Society for Adolescent Medicine</i> , 52(3), 330–335.e3.	Qualitative focus group of highschool athletes (football, soccer). Discussion of concussion knowledge and hypothetical scenarios.	Participants could describe concussion symptoms, understood dangers, and awareness of long term risk. However, high levels of not reporting/continuing to play in scenarios.	Management
Cook, D. J., Cusimano, M. D., Tator, C. H., & Chipman, M. L. (2003). Evaluation of the ThinkFirst Canada, Smart Hockey, brain and spinal cord injury prevention video. <i>Injury prevention : journal of the</i>	Test of concussion knowledge before, within, and after exposure to educational intervention in young ice hockey players.	Minor increase in concussion knowledge and number of reported concussions lasting to three months. No decrease in total penalties.	Management

<p>International Society for Child and Adolescent Injury Prevention, 9(4), 361–6.</p>			
<p>Davies, R., & McMillan, T. M. (2005). Opinion about post-concussion syndrome in health professionals. <i>Brain injury</i>, 19(11), 941–7.</p>	<p>Survey of UK A&E doctors, neurosurgeons, and clinical neuropsychologists. Predictions of symptom complaint based on vignette about mTBI and a PCS knowledge questionnaire.</p>	<p>Headache, attention, and memory difficulties listed as symptoms. Variation in listed symptoms and optimism about recovery between professions. Organic factors cited as main cause, followed by emotional and compensation.</p>	<p>Symptomology</p>
<p>Doolan, A. W., Day, D. D., Maerlender, A. C., Goforth, M., & Gunnar Broinson, P. (2012). A review of return to play issues and sports-related concussion. <i>Annals of biomedical engineering</i>, 40(1), 106–13.</p>	<p>Review of literature on return to play guidelines.</p>	<p>Literature is unclear and contradictory regarding diagnosis and approach. Need for a generalised systematic approach based on current best-practice, with a focus on long-term athlete health.</p>	<p>Management</p>
<p>Finch, C. F., McIntosh, A. S., & McCrory, P. (2001). What do under 15 year old schoolboy rugby union players think about protective headgear? <i>British journal of sports medicine</i>, 35(2), 89–94.</p>	<p>Survey young rugby union players on head injuries, attitudes, and use of preventive equipment.</p>	<p>Mixed views on headgear use dependent on safety concerns and experience. Reports of rougher play with a helmet.</p>	<p>Prevention</p>
<p>Kerr, Z. Y., Register-Mihalik, J. K., Marshall, S. W., Evenson, K. R., Mihalik, J. P., & Guskiewicz, K. M. (2014). Disclosure and non-disclosure of concussion and concussion symptoms in athletes: Review and application of the socio-ecological</p>	<p>Literature review of studies on disclosure of concussion/ concussion symptoms.</p>	<p>Non-disclosure reasons across all studies organised in to four socio-ecological levels: intra-personal, inter-personal, environment, and policy. Less emphasis on environment and policy levels found in literature.</p>	<p>Management</p>

framework. Brain injury, 9052(April), 1–13.			
Kroshus, E., Baugh, C. M., Daneshvar, D. H., & Viswanath, K. (2014). Understanding concussion reporting using a model based on the theory of planned behavior. The Journal of adolescent health : official publication of the Society for Adolescent Medicine, 54(3), 269–274.e2.	Survey of junior ice-hockey players on symptom reporting, intention, perceived norms, self-efficacy, perceived outcomes, and concussion knowledge.	Models support Theory of Planned Behaviour model explaining concussion reporting behaviour. Strong link between athletic performance and reporting intention.	Management
Kroshus, E., Daneshvar, D. H., Baugh, C. M., Nowinski, C. J., & Cantu, R. C. (2014). NCAA concussion education in ice hockey: an ineffective mandate. British journal of sports medicine, 48(2), 135–40.	Survey of ice-hockey players before and after varying concussion education interventions. Measuring attitudes, knowledge, perceived norms, and behavioural intent. Qualitative assessment of education content.	Recall differed by intervention, but no significant improvements in knowledge with a small decrease in playing with symptomology. Suggests future evidence based education.	Management
McBeath, J. (2000). Labeling of Postconcussion Patients as Malingering and Litigious: A Common Practice in Need of Criticism. Headache, 2000(40), 609-610.	Letter to editor reviewing incidence, literature, and personal medical experience.	Concern regarding patients seeking care with concussion symptomology, and the role of psychological factors when lacking organic evidence.	Symptomology
McCrea, M., Hammeke, T., Olsen, G., Leo, P., & Guskiewicz, K. (2004). Unreported concussion in high school football players: implications for prevention. Clinical journal of sport medicine : official journal of the Canadian Academy	Retrospective survey of highschool football players at end of season. Number of concussions and if reported.	Higher than expected levels of concussion in high-school groups, with low levels of reporting.	Management

of Sport Medicine, 14(1), 13–7.			
McKinlay, Bishop, & McLellan, T. (2011). Public knowledge of “concussion” and the different terminology used to communicate about mild traumatic brain injury (MTBI). <i>Brain injury</i> , 25(7-8), 761–6.	General public polled on experience and understanding of concussion with a self-report survey.	Poor knowledge of concussion symptoms with higher negative attributes associated with brain injury over head injury. Level of positive attribution associated with mTBI experience, but high levels of incorrect labelling of injury.	Symptomology
Mulhern, S., & McMillan, T. M. (2006). Knowledge and expectation of postconcussion symptoms in the general population. <i>Journal of psychosomatic research</i> , 61(4), 439–45.	General public reported expected symptoms from vignettes about mTBI, depression, PTSD, and orthopaedic injury.	Poor generation of symptoms for PCS, depression, and PTSD. Knowledge not influenced by past mTBI experience, but with beliefs about undesirability.	Symptomology
Pettersen, J. (2002). Does rugby headgear prevent concussion? Attitudes of Canadian players and coaches. <i>British journal of sports medicine</i> , 36(1), 19–22.	Questionnaire-Canadian rugby players attitudes towards headgear and actual use.	Safe attitudes towards rugby headgear but poor reported use. Coaches poor attitudes compared to players.	Prevention
Register-Mihalik, J. K., Linnan, L., Marshall, S. W., Valovich McLeod, T. C., Mueller, F. & Guskiewicz, K. M. (2013). Using theory to understand high school aged athletes’ intentions to report sport-related concussion: Implications for concussion education initiatives. <i>Brain injury</i> , 27(7-8), 878–86.	Survey on contributing factors to intention of reporting concussion symptoms in highschool athletes.	Direct attitude, subjective norm and direct perceived behavioural control associated with intention to report concussion. Improving reporting initiatives should focus on improving attitudes in coaches, players, and parents.	Management
Rivara, F. P., Schiff, M., Chrisman, S. P., Chung, S. K.,	Collection of data on concussion occurrence, incidences of playing	High levels of playing with concussion symptoms, Poor coach	Management

Ellenbogen, R. G., & Herring, S. (2014). The effect of coach education on reporting of concussions among high school athletes after passage of a concussion law. <i>The American journal of sports medicine</i> , 42(5), 1197–203.	with symptoms, and influence of coach education type. Highschool football and female soccer athletes	awareness association with interventions, with video and quizzes associated with lower likelihood of awareness.	
Rosenbaum, A. M., & Arnett, P. (2010). The development of a survey to examine knowledge about and attitudes toward concussion in high-school students. <i>Journal of clinical and experimental neuropsychology</i> , 32(1), 44–55.	Development and testing of a concussion knowledge and attitude measure in highschool students – RoCKAS-ST.	Fair-satisfactory test-retest reliability. Findings suggest a stable measure of concussion attitudes and an acceptable measure of concussion knowledge. More comprehensive than previous measures.	Management
Sarmiento, K., Mitchko, J., Klein, C., & Wong, S. (2010). Evaluation of the Centers for Disease Control and Prevention’s concussion initiative for high school coaches: “Heads Up: Concussion in High School Sports”. <i>The Journal of school health</i> , 80(3), 112–8.	Survey and focus groups (qualitative and quantitative) of high school coaches’ following concussion knowledge intervention.	Reported improvement in concussion prevention and management knowledge, attitudes, and practices.	Prevention
Sawyer, R. J., Hamdallah, M., White, D., Pruzan, M., Mitchko, J., & Huitric, M. (2010). High school coaches’ assessments, intentions to use, and use of a concussion prevention toolkit: Centers for Disease Control and Prevention’s heads up: concussion in	Telephone survey of school coaches’ perceptions and use of concussion prevention toolkit.	In schools with no current prevention plan – positive reports on the use of the toolkit to create one. In those with a current prevention plan – positive reports of plans to use the kit materials to improve it. Kit assessed as easy to use and appropriate. Greater satisfaction was associated with	Prevention

high school sports. Health promotion practice, 11(1), 34–43.		other concussion prevention materials.	
Sullivan, K A, & Edmed, S. L. (2012a). An examination of the expected symptoms of postconcussion syndrome in a nonclinical sample. The Journal of head trauma rehabilitation, 27(4), 293–301.	Healthy university students with no brain injury history reported expected symptomology based on concussion vignettes. Prompts were open-ended questions, prompted interview questions, and a checklist.	More symptoms expected when prompted with interview questions or the checklist compared to baseline. This was not present in the open-ended method, and personal knowledge of mTBI did not alter expectancies	Symptomology
Sullivan, K. A., & Edmed, S. L. (2012b). Systematic variation of the severity of motor vehicle accident-related traumatic brain injury vignettes produces different post-concussion symptom reports. The Clinical neuropsychologist, 26(8), 1255–77.	Undergraduate students responded to vignettes describing very mild, mild, or moderate-mild motor vehicle-related TBI. Participants reported on expected symptomology, concussion knowledge and perceived undesirability of TBI.	mTBI knowledge was not related to differences in expected symptomology, and perceived undesirability only influenced symptom reporting in moderate-severe TBI.	Symptomology
Sye, G., Sullivan, S. J., & McCrory, P. (2006). High school rugby players' understanding of concussion and return to play guidelines. British journal of sports medicine, 40(12), 1003–5.	Survey of high school rugby players on knowledge of concussion return to play guidelines.	Poor knowledge of concussion guidelines with poor adherence to protocol. Knowledge primarily obtained from teachers/coaches and medical personnel.	Management
Torres, D. M., Galetta, K. M., Phillips, H. W., Dziemianowicz, E. M. S., Wilson, J. A., Dorman, E. S., ... Balcer, L. J. (2013). Sports-related concussion: Anonymous survey of a collegiate cohort. Neurology. Clinical	Online survey of athlete's knowledge of concussion and symptoms, and estimates of concussion reporting,	High levels of hiding concussion symptoms, and moderate levels of under-reporting.	Management

practice, 3(4), 279–287.	Whittaker, R., Kemp, S., & House, A. (2007). Illness perceptions and outcome in mild head injury: a longitudinal study. <i>Journal of neurology, neurosurgery, and psychiatry</i> , 78(6), 644–6.	Data collected on symptomology, illness perceptions, PTSD, anxiety, and depression after being admitted to A&E with mTBI and at 3 months follow-up.	Higher risk of experiencing significant enduring post-concussional symptoms associated with belief that their symptomology will have serious negative long-term consequences.	Symptomology
Wood, R. (2004). Understanding the “miserable minority”: a diathesis-stress paradigm for post-concussional syndrome. <i>Brain injury</i> , 18(11), 1135–53.	Review of post-concussion syndrome based on a diathesis-stress paradigm – interaction between psychological and physiological factors in maintaining symptomology and the role of interventions.	Symptoms reported between 3 months and 3 years post-injury with some continuing to experience symptoms up to 15 years. Early intervention can significantly reduce number and intensity of symptoms but rarely available to patients.	Symptomology	

APPENDIX D: SAM Assessment

(Palombo, Williams & Abdi, 2013, APPENDIX), Copyright 2012 Baycrest Centre for Geriatric Care.

Appendix. SAM – 26 items^{1,2}

Copyright © 2012 Baycrest Centre for Geriatric Care.

Please indicate the strength of your agreement with each of the following statements.

- 1 Strongly disagree
- 2 Disagree somewhat
- 3 Neither agree nor disagree
- 4 Agree somewhat
- 5 Agree strongly

Episodic (event)

1. **Specific events are difficult for me to recall (R)**
2. When I remember events, I have a hard time determining the order of details in the event (R)
3. **When I remember events, in general I can recall objects that were in the environment**
4. When I remember events, in general I can recall what I was wearing
5. I am highly confident in my ability to remember past events
6. **When I remember events, I remember a lot of details**
7. When I remember events, in general I can recall which day of the week it was
8. When I remember events, in general I can recall people, what they looked like, or what they were wearing

Semantic

1. I can learn and repeat facts easily, even if I don't remember where I learned them
2. After I have read a novel or newspaper, I forget the facts after a few days (R)
3. After I have met someone once, I easily remember his or her name

¹ (R) – Reverse Coded Items, 10 Brief SAM (B-SAM) items indicated in bold.

² While the items are reproduced in the Appendix, derivation of SAM/B-SAM dimension scores cannot be attained simply by summing the responses to these items. Please contact the authors for information on proper administration and scoring of the SAM/B-SAM. The SAM/B-SAM is Copyright © 2012 to Baycrest Centre for Geriatric Care, all rights reserved.

4. I can easily remember the names of famous people (sports figures, politicians, celebrities)
5. I have a hard time remembering information I have learned at school or work (R)
6. I am very good at remembering information about people that I know (e.g., the names of a co-worker's children, their personalities, places friends have visited etc.)

Spatial

1. In general, my ability to navigate is better than most of my family/friends
2. **After I have visited an area, it is easy for me to find my way around the second time I visit**
3. I have a hard time judging the distance (e.g., in meters or kilometers) between familiar landmarks (R)
4. **I get lost easily, even in familiar areas (R)**
5. If my route to work or school was blocked, I could easily find the next fastest way to get there
6. I use specific landmarks for navigating

Future

1. **When I imagine an event in the future, the event generates vivid mental images that are specific in time and place**
2. When I imagine an event in the future, I can picture the spatial layout
3. When I imagine an event in the future, I can picture people and what they look like
4. When I imagine an event in the future, I can imagine how I may feel
5. **When I imagine an event in the future, I can picture images (e.g., people, objects, etc)**
6. I have a difficult time imagining specific events in the future (R)

APPENDIX E: Concussion Attitude (Rosenbaum and Arnett, 2010)

Section 3

DIRECTIONS: For each question circle the number that best describes how you feel about each statement.

	<i>Strongly Disagree</i>	<i>Disagree</i>	<i>Neutral</i>	<i>Agree</i>	<i>Strongly Agree</i>
1 I would continue playing a sport while also having a headache that resulted from a minor concussion.	1	2	3	4	5
2 I feel that coaches need to be extremely cautious when determining whether an athlete should return to play.	1	2	3	4	5
3 I feel that mouthguards protect teeth from being damaged or knocked out.	1	2	3	4	5
4 I feel that professional athletes are more skilled at their sport than high-school athletes.	1	2	3	4	5
5 I feel that concussions are less important than other injuries.	1	2	3	4	5
6 I feel that an athlete has a responsibility to return to a game even if it means playing while still experiencing symptoms of a concussion.	1	2	3	4	5
7 I feel that an athlete who is knocked unconscious should be taken to the emergency room.	1	2	3	4	5
8 I feel that most high-school athletes will play professional sports in the future.	1	2	3	4	5

APPENDIX F: Concussion Knowledge (Weber & Edwards, 2012, p.358)

-
1. An SC is harmless and never results in long-term problems or brain damage (F)
 2. A little brain damage does not matter, as people use a small portion of their brains anyway (F)
 3. An SC can cause brain damage even if the sports person is not knocked out (T)
 4. In sport, SC almost never happens (F)
 5. Most sports persons with SC are not fully aware of its effect on their behavior and performance (T)
 6. Sometimes a second blow to the head can help a sports person remember things that were forgotten (F)
 7. Once a recovering sports person feels "back to normal," the recovery process is complete (F)
 8. Complete recovery from an SC is not possible, no matter how badly the person wants to recover (F)
 9. Drinking alcohol may affect a sports person differently after an SC (T)
 10. How quickly a sports person recovers from an SC depends mainly on how hard they work on recovery (F)
 11. It is easy to tell if a sports person has brain damage from an SC by the way the person looks or acts (F)
 12. Whiplash injuries to the neck can cause brain damage even if there is no direct blow to the head (T)
 13. It is good advice to rest and remain inactive during recovery (F)
 14. In sports, an SC can have positive and negative effects on the sports person (F)
 15. Concussed sports persons usually show good understanding of their problems because they experience them every day (F)
 16. An SC may cause one to feel depressed, hopeless, and sad (T)
 17. Emotional problems after SC are usually not related to brain damage (F)
 18. Recovery from an SC is usually complete in about a week (F)
 19. The only sure way to tell if someone has suffered brain damage from an SC is by an X-ray of the brain (F)
 20. A sports person who has recovered from an SC is less able to withstand a second blow to the head (T)
 21. Asking sports persons who were concussed about their recovery is the most accurate, informative way to find out how they have progressed (F)
 22. When a sports person is knocked unconscious, most wake up quickly with no lasting effects (F)
 23. Sports persons usually have more trouble remembering things that happen after an SC than remembering things from before (T)
 24. A concussed sports person may have trouble remembering events from before the concussion, but usually does not have trouble learning new things (F)
 25. An SC affects men's and women's brains differently (T)
 26. Sports people who have had one SC are more likely to have another (T)
-