

This is an Open Access document downloaded from ORCA, Cardiff University's institutional repository: <https://orca.cardiff.ac.uk/id/eprint/126593/>

This is the author's version of a work that was submitted to / accepted for publication.

Citation for final published version:

Thaore, Vaishali B., Armstrong, Robert D., Hutchings, Graham J., Knight, David W., Chadwick, David and Shah, Nilay 2020. Sustainable production of glucaric acid from corn stover via glucose oxidation: an assessment of homogeneous and heterogeneous catalytic oxidation production routes. *Chemical Engineering Research and Design* 153 , pp. 337-349. 10.1016/j.cherd.2019.10.042

Publishers page: <http://dx.doi.org/10.1016/j.cherd.2019.10.042>

Please note:

Changes made as a result of publishing processes such as copy-editing, formatting and page numbers may not be reflected in this version. For the definitive version of this publication, please refer to the published source. You are advised to consult the publisher's version if you wish to cite this paper.

This version is being made available in accordance with publisher policies. See <http://orca.cf.ac.uk/policies.html> for usage policies. Copyright and moral rights for publications made available in ORCA are retained by the copyright holders.



1 Sustainable production of glucaric acid from corn stover via glucose  
2 oxidation: an assessment of homogeneous and heterogeneous catalytic  
3 oxidation production routes

4 *Vaishali B. Thaore<sup>\*1</sup>, Robert D. Armstrong<sup>2</sup>, Graham J. Hutchings<sup>2</sup>, David W. Knight<sup>2</sup>,*

5 *David Chadwick<sup>1</sup>, Nilay Shah<sup>1</sup>*

6 <sup>1</sup>Department of Chemical Engineering, Imperial College London, South Kensington,

7 London SW7 2AZ, United Kingdom

8 <sup>2</sup>Cardiff Catalysis Institute, School of Chemistry, Cardiff University, Main Building, Park Place,

9 Cardiff CF10 3AT, United Kingdom

10

11

12 \*To whom correspondence should be addressed:

13 E-mail address: [v.thaore@imperial.ac.uk](mailto:v.thaore@imperial.ac.uk) (Vaishali B. Thaore)

14

1 **Abstract**

2 Glucaric acid is being used increasingly as a food additive, corrosion inhibitor, in deicing, and in  
3 detergents, and is also a potential starting material for the production of adipic acid, the key  
4 monomer for nylon-66. This work describes a techno-economic analysis of a potential bio-based  
5 process for the production of pure glucaric acid from corn stover (biomass). Two alternative  
6 routes for oxidation of glucose to glucaric acid are considered: via heterogeneous catalytic  
7 oxidation with air, and by homogeneous glucose oxidation using nitric acid. Techno-economic  
8 and lifecycle assessments (TEA, LCA) are made for both oxidation routes and cover the entire  
9 process from biomass to pure crystalline glucaric acid that can be used as a starting material for  
10 the production of valuable chemicals. This is the first TEA of pure glucaric acid production  
11 incorporating ion exchange and azeotropic evaporation below 50°C to avoid lactone formation.  
12 The developed process models were simulated in Aspen Plus V9. The techno-economic  
13 assessment shows that both production routes are economically viable leading to minimum  
14 selling prices of glucaric acid of ~ \$2.53 /kg and ~ \$2.91 /kg for the heterogeneous catalytic  
15 route and the homogeneous glucose oxidation route respectively. It is shown that the  
16 heterogeneous catalytic oxidation route is capable of achieving a 22% lower environmental  
17 impact than the homogeneous glucose oxidation route. Opportunities for further improvement in  
18 sustainable glucaric acid production at industrial scale are identified and discussed.

19 **Keywords:** sustainable, environmental, glucaric acid, techno-economic, oxidation.

20

## 1 **Introduction**

2 Increased energy usage is leading to increasing greenhouse gas (GHG) emissions (EPA, 2017;  
3 Fishedick et al., 2014) largely due to a dependence upon fossil fuel-derived energy (IEA, 2008).  
4 Manufacturing including chemical manufacturing accounts for 24% of total GHG emissions  
5 (Brown et al., 2012). This has incentivized the development of energy-efficient technologies and  
6 processes based on the use of sustainable feedstocks in chemical manufacturing. Utilization of  
7 biomass as an alternative feedstock to hydrocarbons can be the basis of sustainable processes as  
8 long as it is non-competitive with food crops (Brown et al., 2012; Fernando et al., 2006). In  
9 recent years, the potential of biomass for use in the manufacturing of industrial chemicals has  
10 been widely explored (Biddu et al., 2016; Boussie et al., 2016; Bozell and Petersen, 2010; Han et  
11 al., 2014; Mussatto and Dragone, 2016; Sen et al., 2012; Van Duuren and Wittmann, 2014;  
12 Werpy and Petersen, 2004). Improvements in biomass pretreatment, saccharification  
13 technologies and processes for the fermentative/catalytic conversion of cellulosic feedstocks into  
14 desirable products pave the way for sustainable chemical production (Van Duuren and  
15 Wittmann, 2014). Glucaric acid (GA) is a value-added biomass-derived commodity chemical  
16 listed by the US-Department of Energy as one of the top value-added chemicals (Werpy and  
17 Petersen, 2004). GA and its derivatives find many applications in food, pharmaceutical and  
18 chemical industries (Walaszek, 1990; Walaszek et al., 1996) and recently it has been proposed as  
19 a key intermediate in the production of bio-derived adipic acid (Boussie et al., 2013).

20 GA occurs naturally in fruits and vegetables, and can also be produced synthetically from  
21 glucose via electrochemical, chemical, biochemical and chemocatalytic oxidation (Bin et al.,  
22 2014; Gupta et al., 2016; Lee et al., 2016). The oxidation of glucose with nitric acid is the main  
23 commercial route for GA production (Smith et al., 2012), which utilises mild temperatures (25-

1 40°C) and pressures (1-2 bar). Through base-neutralization, GA can be isolated as its calcium or  
2 potassium gluconate salts. However, the process suffers from low GA yields (45%) due to  
3 formation of many co-products including gluconic, 5-ketogluconic, tartaric and oxalic acids  
4 (Smith et al., 2012). An alternative approach is the heterogeneous catalytic selective oxidation of  
5 glucose. This occurs in a two-step process in which the first oxidation step to gluconic acid has  
6 been widely studied over a range of monometallic and bimetallic catalysts (Besson et al., 2014;  
7 Comotti et al., 2006; Miedziak et al., 2014). The most commonly used catalyst is Pt/C with  
8 various promoters, for example by Bi (Deller et al., 1992), which serve to mitigate deactivation  
9 and increase selectivity by suppressing the unwanted formation of 2-ketogluconic acid. The  
10 second oxidation step leading to GA formation is more difficult and consequently reports on  
11 direct catalytic oxidation of glucose to GA are relatively limited, although the production of GA  
12 is receiving increasing attention. For example, Jin et al., (Jin et al., 2015) recently reported a  
13 highly active PtCu<sub>3</sub>/TiO<sub>2</sub> catalyst for oxidation of sodium gluconate to gluconate in strong base.  
14 In a commercial patent Rennovia claimed a process for production of adipic acid via oxidation of  
15 glucose to GA (Boussie et al., 2013). Examples of glucose oxidation in non-basic conditions (in  
16 acetic acid) over a range of Pt supported catalysts were reported with maximum GA yields of 57-  
17 60% (Boussie et al., 2013). The Rennovia patent also presented examples on adipic acid  
18 production via hydrodeoxygenation of GA in the presence of HBr.

19 A sustainable commercial GA production process can be based on glucose oxidation by either  
20 the heterogeneously catalyzed and nitric acid-mediated routes (Boussie et al., 2013; Smith et al.,  
21 2012). However, these generally produce GA as the potassium, sodium or calcium gluconate  
22 salts. The process patented by Rennovia yields GA in acetic acid which it was claimed can be  
23 used directly in hydrodeoxygenation (HDO) to adipic acid. To address product separation,

1 Rennovia have recently patented a process for GA recovery via ion exchange chromatography,  
2 with selective elution by organic acids such as formic or acetic acid (Diamond et al., 2016).  
3 Yuan et al. also reported solid phase extraction of GA from aqueous solution using polymeric ion  
4 exchange resin and non-ionic adsorbents (Yuan et al., 2017). However, while these reports  
5 describe promising methods for GA purification, they lack detailed experimental analyses on the  
6 recovered GA. Recently, Armstrong et al. reported a low temperature method for isolating pure  
7 GA from dilute aqueous  $K^+$  or  $Ca^+$  glucarate solutions (Armstrong et al., 2017), and presented  
8 the first powder X-ray diffraction pattern of crystalline GA (Armstrong et al., 2017). In this  
9 innovative approach, a two-step process is used whereby dilute glucarate salt solutions are  
10 contacted with amberlyst-15 ( $H^+$ ) exchange resin followed by azeotropic evaporation at low  
11 temperature, thereby avoiding lactone formation, and yielding ultimately 99.9% pure crystalline  
12 GA. In principle, production of crystalline GA as an intermediate avoids the need for a fully  
13 integrated process from biomass to final end product (adipic acid) (Boussie et al., 2016) and can  
14 simplify the potential supply chains.

15 In this work we present techno-economic analysis (TEA) and life cycle analysis (LCA) for the  
16 production of GA from corn stover, which is an agricultural waste available in large quantity.  
17 Both the heterogeneous catalytic (Route 1) and homogeneous- $HNO_3$  (Route 2) glucose oxidation  
18 routes have been evaluated. The process models are integrated with a GA purification step based  
19 on ion exchange and low temperature azeotropic evaporation to avoid lactone formation. The GA  
20 ion exchange adsorption data reported by Yuan et al., has been used to model the ion exchange  
21 column with integration of the azeotropic evaporation method reported by Armstrong et al., to  
22 give a novel process (Yuan et al., 2017; Armstrong et al., 2017). The comparative assessment  
23 and sensitivity analysis for pure GA production via either glucose oxidation route presented here,

1 paves the way for an economical and sustainable route to synthesis of this commodity chemical  
2 at an industrial scale.

### 3 **Materials and methods**

#### 4 *An innovative approach towards producing renewable, pure GA*

5 Corn stover biomass is used as a starting material for the renewable production of glucaric  
6 acid. The process flow model was developed for the two production routes proposed and, in both  
7 routes, include detailed mass and energy balances for the entire process from corn stover to GA.  
8 The process is designed to target production capacities suitable for use of GA as a commercial  
9 product or by small scale industries, or for an adipic acid demonstration plant where glucaric  
10 acid is the starting material. This is done by considering  $\sim 1/3^{\text{rd}}$  capacity of the NREL bioethanol  
11 model (Humbird et al., 2011). The ready availability of pure glucaric acid would encourage  
12 development of further conversions into other important glucaric acid derivatives such as esters,  
13 ketones and lactones which have pharmaceutical applications (Lampe et al., 2002; Walaszek,  
14 1990; Walaszek et al., 1996).

15 The overall GA process flow model consists of stepwise processes, namely (i) biomass  
16 pretreatment-cellulase-catalyzed enzymatic saccharification and (ii) oxidation of glucose to GA  
17 followed by (iii) its purification and recovery. The general process scheme for glucaric acid  
18 production from biomass-derived glucose is shown in Figure 1. A schematic process flow  
19 diagram for corn stover conversion to glucaric acid is shown in Figure S.1 of the Supporting  
20 Information section S.I. A separate process model has been developed for each of the alternative  
21 oxidation routes. The model also considers wastewater treatment and utilities required for GA  
22 production. The latter includes cooling water, steam and electricity generation, integrating the

1 combustor and boiler operations into the process flowsheet. All cost estimates are given in US  
2 dollars \$ (USD).

3 The process flow model was designed and simulated in the process simulation software Aspen  
4 Plus V9. The composition of the corn stover biomass used as a feedstock to produce GA in both  
5 production routes is specified in Supporting Information section S.I, Table S.1. The physical and  
6 chemical properties of all components were assigned according to the Aspen Plus V9 database  
7 and property data developed by the National Renewable Energy Laboratory (NREL) for  
8 biochemical conversion of lignocellulosic biomass to ethanol (Humbird et al., 2011). For GA and  
9 potassium glucarate components, the physicochemical properties were estimated based upon  
10 their molecular structures. These properties are given in the Supporting Information Table S.2  
11 (Vasiliu et al., 2011; Joback and Reid, 1987). The simulation of a designed process model was  
12 performed using a non-random two-liquid (NRTL) thermodynamic model with Henry's law for  
13 gaseous component.

14 The model was designed to process 12000 kg/hr of biomass-derived glucose in both  
15 production Routes 1 and 2, to produce GA as a commodity intermediate chemical. The process  
16 flow model was divided into 9 process areas by considering each of the steps shown in Table 1.

17 The overall schematic process flow diagram from corn stover to glucaric acid is shown in  
18 Figure S.2. The process model involving biomass conversion to glucose, i.e. from process area  
19 A100 to A300, was designed based on an earlier article by the current authors on caprolactone  
20 production from corn stover biomass (Thaore et al., 2018) and the National Renewable Energy  
21 Laboratory ethanol production model from biomass (Humbird et al., 2011). This involves  
22 biomass conversion to cellulose by steam and acid hydrolysis followed by enzymatic



1 saccharification into glucose. The detailed description of each reaction as well as conditions for  
2 process areas A100 to A300 are the same as those previously reported (Thaore et al., 2018); they  
3 are reproduced in Supporting Information Table S.3. After saccharification, one more step is  
4 included for concentration of sugar stream from 13 to 50% w/w using mechanical vapor  
5 recompression (MVR) evaporator and then glucose was separated from sugars mixture by  
6 considering component separator block. For this we referred to the NREL 2017 biochemical  
7 sugar model (NREL 2017 biochemical sugar model (BC1707A), 2017). On an industrial scale,  
8 glucose could be separated using a cation exchange resin from other sugar components such as  
9 xylose and arabinose present in lignocellulosic hydrolysates stream (Chen et al., 2018). Thus, in  
10 this process a sugar stream containing xylose and arabinose is generated as a byproduct.

### 11 **Glucose oxidation to GA**

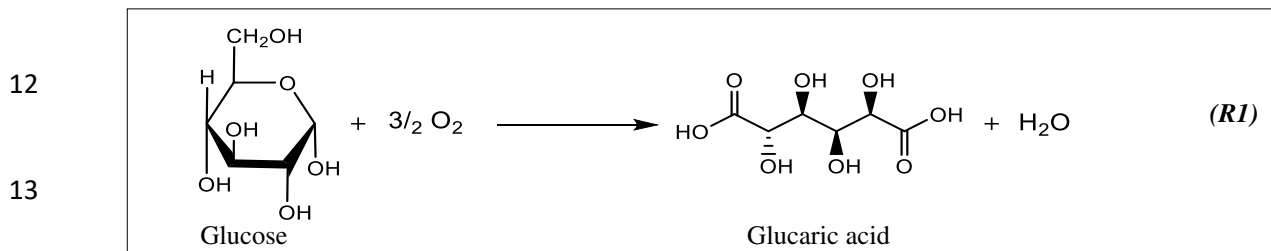

### 14 **Route 1: Heterogeneous catalytic oxidation of glucose**

15 For the heterogeneous catalytic oxidation route, the process model was designed with 10%  
16 w/w glucose solution based on data taken from the Rennovia patent (Boussie et al., 2013), which  
17 reported heterogeneous glucose oxidation using air at pressures of 35-40 bar and temperatures of  
18 80°C - 90°C achieving GA yields of 50-60%. A 5 wt% Pt/C catalyst has been considered for GA  
19 production based on the Rennovia patent (Boussie et al., 2013). Pt/C is a readily available  
20 commercial catalyst and its performance was reported to be amongst the best of the catalysts  
21 tested. In the present process model, glucose oxidation is represented by the reaction *R1* using  
22 the stoichiometric reactor model operating at 35 bar air pressure and a temperature of 80°C. A

1 GA yield of 60% has been assumed based on the experimental studies of Lee et al. (2016) and is  
2 also consistent with the reported yields in the Rennovia patent (Boussie et al., 2013) for similar  
3 catalysts. The amount of catalyst for the glucose oxidation step in Route 1 was estimated based  
4 on the reported productivity in Lee et al. (2016). The 5 wt% Pt/C catalyst initially charged  
5 corresponded to a glucose (in 1 hr): Pt molar ratio = 54 :1 or a glucaric acid productivity of 32.36  
6  $\text{mol}_{\text{GA}} \cdot \text{mol}_{\text{Pt}}^{-1} \cdot \text{h}^{-1}$  in a continuous fixed-bed oxidation reactor. The industrial-scale Pt/C catalyst  
7 cost was conservatively assumed to be 50% of the Sigma Aldrich catalyst price (Sigma Aldrich:  
8 Platinum on carbon, 5 wt% loading, matrix activated carbon support, 2018). The catalyst amount  
9 was considered as the initial capital catalyst charge to process 12000 kg/hr of glucose.

#### 10 *GA neutralization*

11 The oxidized mixture was neutralized by adding 45% KOH to maintain a stoichiometric ratio  
12 of 1.015:1 KOH: GA. The addition of base resulted in formation of GA's potassium salt  
13 (potassium glucarate). Following cooling to 30 °C, solid potassium glucarate was then separated  
14 using a solid-liquid separator. The separated liquid solution, which contained un-reacted glucose,  
15 was sent to the anaerobic digester for generation of biogas.

#### 16 ***Route 2: Homogeneous oxidation of glucose using nitric acid reagent***

17 Route 2 was based on the controlled nitric acid oxidation of glucose to GA as reported by  
18 Smith et al (Smith et al., 2012). They used 62.3 wt% glucose at a 3:1 molar ratio nitric acid:  
19 glucose and performed the reaction at the relatively low temperature of 25-40 °C and maintained  
20 a reactor pressure of 0.25-0.5 barg with air as the oxidizing agent (Smith et al., 2012). Under  
21 these conditions Smith et al. reported 40-45% yield of GA (Smith et al., 2012). Therefore,  
22 similar conditions have been used in the present process model. Similar to reaction condition  
23 used by Smith et al, here 62.3 wt% glucose solution was maintained for nitric acid oxidation by

1 diluting glucose stream. The concentrated glucose solution was then oxidized to GA using 70%  
2 w/w nitric acid. The stoichiometric reactor model was used based on reaction R1 for the  
3 oxidation process operating at 2 bar air pressure and at 40°C with addition of 70% w/w nitric  
4 acid to maintain the 3:1 molar ratio of nitric acid: glucose.

#### 5 *Neutralization of the oxidized mixture*

6 Neutralization of the glucose oxidation product mixture with KOH resulted in formation of  
7 monopotassium glucarate and potassium nitrate. Smith et al. have proposed nanofiltration and  
8 diffusion dialysis for nitric acid removal (Smith et al., 2012). It allows separation of inorganic  
9 nitrate from salts of oxidation products by passing the neutralized mixture through a  
10 nanofiltration membrane. However, in general dilute product streams (%w/w) are favored when  
11 using nanofiltration membranes. Hence, to achieve salt separation at an industrial scale, the  
12 product streams would require significant dilution with water prior to nanofiltration. Energy  
13 intensive unit operations such as evaporation or distillation are then required in isolating  
14 monopotassium glucarate. Smith et al. have also proposed the use of diffusion dialysis (DD)  
15 prior to the neutralization step (Smith et al., 2012). This would separate inorganic and organic  
16 acids. The advantage of DD over nanofiltration is that it allows for processing of low pH streams  
17 containing high nitric acid concentrations. Therefore, DD would circumvent the need for an  
18 additional dilution step if operated on an industrial scale.

19 In the present process model, nitric acid was separated prior to the neutralization step by  
20 employing a component separator block to represent the DD step in the process flowsheet. Thus,  
21 the spent nitric acid was recycled back to the oxidation reactor, thereby reducing the nitric acid  
22 consumption rate. Then, neutralization of the glucose oxidation mixture was performed in a  
23 similar way to that explained in Route 1 through the addition of 45 % KOH (1.015:1 molar ratio

1 of KOH: glucose). Solid potassium gluconate was separated from the unreacted glucose solution  
2 and then passed to the next step of GA purification, whilst the unreacted glucose solution was  
3 sent to anaerobic digester in A600 for generation of biogas.

#### 4 ***GA purification***

5 Armstrong et al. have described a procedure to obtain the pure solid form of free- GA  
6 (Armstrong et al., 2017). The first step is to contact the gluconate solution with amberlyst-15 ion  
7 exchange resin followed by water washing. Contacting the potassium gluconate solution with  
8 amberlyst-15 ion exchange resin leads to > 99% exchange of K<sup>+</sup> for H<sup>+</sup>. After ion-exchange, GA  
9 can be recovered in powder form from the water washing by evaporation. However, during  
10 evaporation of water, even at a reduced pressure of 50 mbar and a temperature 50°C, extensive  
11 lactonization of GA can occur as demonstrated in the detailed NMR study (Armstrong et al.,  
12 2017). With increase in temperature, GA has the tendency to form D-gluconic-1,4:6,3-dilactone,  
13 and in acidic medium it lactonizes more rapidly to D-gluconic-1,4-lactone (Brown et al., 2007).  
14 Lactonization can be avoided using azeotropic evaporation at low temperature < 28 °C for  
15 gluconic acid recovery (Armstrong et al., 2017). In the present process, the azeotrope of GA-  
16 water wash with acetonitrile (95:5) is formed and then evaporated at a reduced pressure of 50  
17 mbar and low temperature (22°C) to yield solid white GA with high purity (99.96%) and yield  
18 (98%).

19 The 10 wt% aqueous monopotassium gluconate solution obtained from the neutralization step  
20 was used for the ion exchange chromatographic purification. In our process model, the  
21 adsorption column was designed based on adsorption parameters reported by Yuan et al. for  
22 solid phase extraction of GA (Yuan et al., 2017). Simulation of the fixed bed adsorption column  
23 including pore diffusion model kinetics and Langmuir adsorption model (Supporting Information

1 S.II) was performed in the gPROMS process modelling platform for an adsorption column of 4  
2 m length and 1 m diameter. A detailed simulation of the GA concentration profile with respect to  
3 bed height is shown in Figure S.3. The resin column parameters were also evaluated based on the  
4 Amberlyst-15 resin capacity provided by the resin manufacturer, Supporting Information section  
5 S.II. There was no significant difference in column design parameters from the column designed  
6 using the adsorption kinetic data of Yuan et al, 2017.

7 The GA-water-acetonitrile azeotrope is evaporated in a series of distillation columns at a  
8 reduced pressure of 50 mbar and 15 mbar to obtain pure solid GA with >97% purity. Table 2  
9 gives the make-up amounts of acetonitrile required for this GA recovery step (for Route 1 and 2).

#### 10 *Wastewater treatment-A600*

11 In Route 1, the combined streams of steam condensate from A800 and cooling water were  
12 treated in aerobic and anaerobic digesters, generating biogas. Route 2 generated an additional  
13 wastewater (WWT) stream as evaporate condensate from process area A400 which was  
14 combined with the steam condensate from A800 combine and with cooling water prior to  
15 treatment in this area. The water stream was recycled to the process water distribution area  
16 A900, whilst the remaining sludge stream containing solids, unconverted cellulose,  
17 hemicellulose, lignin and spent enzymes were sent to the combustor area (A800).

#### 18 *Storage-A700*

19 The raw materials: ammonia, sulphuric acid, nitric acid, 45% KOH, and acetonitrile required  
20 for GA production, are shown in this section and their make-up amounts are given in Table 2.

#### 21 *Combustor, Boiler and turbo-generator-A800*

1 The solid waste stream generated from cellulose saccharification, containing spent cellulase  
2 enzyme and unconverted cellulose combined with solid waste from A600, are combusted in this  
3 area producing steam and electricity. The biogas generated in A600 and pure methane serve as  
4 fuel for the combustor.

#### 5 *Process water and utilities-A900*

6 This area represents the process water distribution required in various processes and also the  
7 cooling water, chilled water utilities distribution for distillation columns and many other  
8 operations. The net amount of electricity, i.e. in terms of net workload for each process area, was  
9 also tracked in this process area.

## 10 **Results and discussion**

11 As noted above, the process model was designed to process 12000 kg/hr of glucose derived  
12 from corn stover into GA in the each of two production routes (heterogeneous catalysis and  
13 homogeneous nitric acid oxidation). In both routes a total of 42.4 tonne/hr (20% moisture) of  
14 biomass was required to produce 12000 kg/hr of glucose. Production Route 1, heterogeneous  
15 selective catalytic oxidation using a commercial Pt/C catalyst, produced 8000 kg/hr of GA. In  
16 Route 2, 6086 kg/hr of GA was obtained by homogeneous glucose oxidation with nitric acid.  
17 During biomass pretreatment, 40% of all sugars was produced as a by-product at rates of 38000  
18 kg/hr and is the same for both Route 1 and Route 2. The rate at which raw materials, solvents  
19 and reactants are required by these processes, complete with respective costs in USD \$, are given  
20 in Table 2. The unitary costs of each input stream are presented in Supporting Information  
21 section S.III, Table S.5.

1 It should be noted that the data presented on the input streams of both production routes,  
2 especially solvent and the reagent-HNO<sub>3</sub>, are the make-up amounts required in the GA  
3 production process model. Recycling of 98% of solvent and HNO<sub>3</sub> back into the process has  
4 been assumed.

### 5 *Financial analysis*

6 The equipment cost for GA production involving biomass handling (A100), pretreatment  
7 (A200) and glucose production (A300) along with that required for wastewater treatment  
8 (A600), boiler/steam generator (A800) and utilities (A900) was estimated using the NREL  
9 equipment list (Humbird et al., 2011). This equipment list was further updated based on the  
10 required equipment size and the CEPCI cost index for 2017 (CEPCI, 2017). The bottom-up  
11 approach proposed by Peters et al was used in determining the cost of equipment for the GA  
12 production area (A400) and purification process area (A500) (Peters et al., 2003). Table 3 shows  
13 the total installed cost of equipment for the bio-based production of GA in both routes.

14 In Route 1, 240 kg of Pt (4800 kg of 5wt% Pt/C catalyst) was loaded for oxidation of 12000  
15 kg/hr of glucose (Glucose (in 1 hr): Pt molar ratio=54). Two reactors have been included: one for  
16 the continuous glucose oxidation reaction, the other for catalyst regeneration, which is assumed  
17 to be by a washing process. The conversion reactor contains 4.8 tonne of catalyst and the total  
18 initial outlay on the catalyst was estimated at \$50.43 million, assuming the cost of the 5 wt%  
19 Pt/C catalyst is 50% of the Sigma Aldrich price. Based on the simulation results for the  
20 purification process, 8 ion exchange columns were required to adsorb 9555 kg/hr of K-glucarate  
21 in Route 1: 4 for both the adsorption and resin regeneration processes each having a length of 4  
22 m and a diameter of 1m. Whereas in Route 2, 6 columns of the same dimensions are required (3  
23 for adsorption and 3 in regeneration) for adsorption of 7279 kg/hr of K-glucarate. A total of

1 26875 kg of ion exchange resin (IER) was loaded into columns for Route 1 and 20625 kg for  
2 Route 2. The outlay on catalyst and IER represents an initial capital cost. Thus, these values were  
3 considered in the total capital investment (TCI). Financial analyses for Routes 1 and 2 are given  
4 in Table 4. These represent the total capital investment (TCI) based on the total cost of installed  
5 equipment, total direct cost (TDC), total indirect cost (TIC) and fixed capital investment (FCI).  
6 The total capital investments are estimated to be \$320 million for Route 1 and \$270 million for  
7 Route 2 for processing 42.4 tonne/hr of corn stover into high purity solid GA.

8 The total annual production costs of these two routes were evaluated taking into account both  
9 fixed and variable operating costs. Estimated costs for consumables, feedstock, utilities and  
10 electricity for Routes 1 and 2 are given in Table 5. Additionally, both processes operate a net  
11 electricity surplus owing to the boiler/steam generator A800: 1.2 MW in Route 1 and 7.5 MW in  
12 Route 2 (Table 3). This could be sold to the national grid. Based on this evaluation, the total  
13 production cost was estimated as \$70.27 million/year to produce 67.20 million kg/year GA via  
14 Route 1 and \$64.17 million /year for 51.12 million kg/year output via Route 2. Based on these  
15 estimates, whilst there is a demonstrable difference in total capital investment required for  
16 Routes 1 and 2, the total production costs are of the same order. The discounted cash flow  
17 analysis method was used to determine a minimum selling price for GA by equating the net  
18 present value to zero at the end of 20 years (Peters et al., 2003). Table S.6 summarises the  
19 discounted cash flow analysis parameters for the new glucaric acid production plant. With an  
20 assumption of constant 35% income tax rate, higher project contingency 40% for the new plant  
21 and 6 years of capital depreciation with a safe acceptable investment by considering the  
22 minimum acceptable annual rate of return (MARR) of 15%, the minimum selling price of GA  
23 was estimated to be \$2.53/kg by Route 1 and \$2.91/kg by Route 2. According to a recent market



1 research report, the global GA market demand for 2016 was estimated at \$550.4 million with key  
2 applications as detergents, food ingredients, corrosion inhibitors and de-icing chemicals  
3 (Glucaric Acid Market Analysis, 2017; Gupta et al., 2016; Walaszek, 1990; Walaszek et al.,  
4 1996). The minimum selling price of GA was estimated to be 1.8 \$/kg when sugarcane-derived  
5 sugar (Sugar Price, 2019) was used as starting material. This 30% reduction in cost is due to  
6 elimination of pre-processing cost involved in the conversion of corn stover biomass into  
7 glucose. In February 2017, Johnson Matthey and Rennovia jointly announced the renewable  
8 production of glucaric acid by heterogeneously catalyzed glucose oxidation (Johnson Matthey  
9 R&D News, 2017; Rennovia Press Release, 2015). Unfortunately, there is currently no available  
10 benchmark- market data as to the minimum selling price of high purity solid GA.

11 A higher GA yield (60 %) has been assumed for catalytic glucose oxidation based on the  
12 Rennovia patent (Boussie et al., 2013) (Route 1) than for nitric acid-mediated oxidation (45%)  
13 (Smith et al., 2012), Route 2. This results in GA-production yields of *ca* 188 kg/tonne of corn  
14 stover biomass in Route 1, and 143 kg/tonne in Route 2. Both production routes are  
15 economically viable based on the assumptions made here. However, there remain significant  
16 challenges especially in the conversion of glucose to GA and in GA separation, which may  
17 hamper commercial application. For instance, Route 1 utilizes an expensive Pt catalyst, where  
18 improvements in performance would have a significant impact. Route 2 uses nitric acid, which  
19 although a very low-cost reagent, is highly corrosive thereby increasing operational risk and  
20 consequently both operating costs and capital investment. Also, due to the highly exothermic  
21 nature of Route 2, GA production requires efficient heat removal and temperature control to  
22 perform the reaction at a 3:1 molar ratio of nitric acid to glucose. Also, the additional capital and  
23 operating costs associated with the nitric acid removal step.

1 The process model could be improved by implementing a purification step for the GA salt  
2 obtained from the neutralization step. In both Routes 1 and 2 conversion of glucose was assumed  
3 to be to GA only. However, with proper experimental analysis of the glucose oxidation mixture,  
4 both quantitative and qualitative, the model could be further refined. Low temperature, stepwise  
5 crystallization would be desirable to separate GA salts from the salts of other product  
6 components: for example, the salts of other acid products formed in Route 1 and 2.

7 One of the problems of using precious metal catalysts is leaching of the metal leading to  
8 deactivation. Glucose and its acids have chelating properties which can enhance leaching.  
9 Carrying out the catalytic oxidation at a controlled high pH by addition of base could reduce  
10 leaching significantly and suppress lactone formation (Boussie et al., 2013). Operating the  
11 oxidation reactor in this mode would eliminate the unit operation of neutralisation after the  
12 glucose oxidation step in Route 1. It would therefore make little change to the estimated MSP of  
13 GA.

14 The impact of uncertainties in the various assumptions is considered further in the sensitivity  
15 analysis below

#### 16 ***Environmental analysis: Water balance and CO<sub>2</sub> balance***

17 The LCA of both routes evaluates the environmental impact of GA production by estimating  
18 the total CO<sub>2</sub> emissions and water mass balance of each process. Based on the CO<sub>2</sub> eq emission  
19 factor of the input streams (Supporting Information section S.III, Table S.7), GHG emissions  
20 were estimated for Route 1 and Route 2 (Table S.8). Figure 2 shows the total estimated CO<sub>2</sub>  
21 equivalent emissions for Routes 1 and 2 to be 1675 kg/tonne GA and 2150 kg/tonne GA  
22 respectively. Route 2 shows 28 % higher CO<sub>2</sub> emissions, generated from the nitric acid reagent

1 used in oxidising glucose. In Route 1, 48% of total emitted CO<sub>2</sub> came from the potassium  
2 hydroxide used in neutralizing GA. In Route 2, potassium hydroxide (37%) and nitric acid (10%)  
3 accounted for major CO<sub>2</sub> emissions. The other input streams also contributed to the total CO<sub>2</sub>  
4 emissions, specifically, corn stover biomass feed (20% in Route 1 and Route 2), ammonia used  
5 in the neutralization step (14% in Route 1 and Route 2) and the cellulase enzyme used in  
6 saccharification (14% in Route 1 and Route 2). CO<sub>2</sub> emissions from the biomass feed could,  
7 however, be utilized during biomass growth stage, making this a net CO<sub>2</sub> sink (negative CO<sub>2</sub>  
8 contribution). To mitigate CO<sub>2</sub> emissions for the enzyme usage, alternative non-enzymatic  
9 cellulose hydrolysis methods could be applied (Luterbacher et al., 2014). To achieve reductions  
10 in CO<sub>2</sub> emissions resulting from use of ammonia in pretreating the biomass would require  
11 development of new technologies. Application of novel technologies such as ionic-liquid assisted  
12 processes could eliminate ammonia from the biomass pretreatment stage and consequently  
13 reduce associated CO<sub>2</sub> emissions. However, due to a lack of comparative assessment of CO<sub>2</sub>  
14 emissions from ionic liquid and acid hydrolysis processes, the use of ammonia cannot be avoided  
15 at this stage.

16 An environmental assessment was also conducted based on water resources required by  
17 production Routes 1 and 2. The water mass balance of input/output streams for process areas  
18 A100 to A500 are presented in Table 6 (a). The overall water balance for GA production is  
19 presented separately in Table 6 (b). Significant water loss was observed due to evaporation from  
20 cooling towers but not from the biomass to GA conversion steps. Thus, improvements in the heat  
21 exchanger network and energy integration could reduce the cooling water requirement and  
22 consequently water loss. The cooling utility distribution for the GA production plant was  
23 estimated as total 64 MW for both production routes (Table 7). Water could also be recovered

1 from the dilute sugar stream (48 wt%) generated as a co-product in both production routes;  
2 38700 kg/hr in Route 1 and Route 2. However, the dilute sugar stream could itself serve as the  
3 byproduct stream. The total water required for the process was estimated as 250 tonne/hr and 156  
4 tonne/hr for Routes 1 and 2 respectively. Of this, cooling tower water make-up constitutes 35 %  
5 of the water required in Route 1 and 56 % in Route 2.

### 6 *Life cycle analysis on electricity generation*

7 For electricity generation, as described earlier, the solid waste stream generated from  
8 cellulose saccharification, biogas generated from aerobic and anaerobic digesters, and  
9 supplemental natural gas were combusted for electricity generation. As shown in Table 3, about  
10 95% of the electricity generated by the boiler in Area 800 is used throughout the plant in Route 1  
11 and 75% in Route 2. The surplus electricity is sold to the grid for credit. This is reflected in the  
12 economics by an operating cost credit equal to this amount of electricity in Table 3. Total CO<sub>2</sub> eq  
13 emissions is evaluated based on supplemental natural gas consumption rate in Area 800. Here,  
14 the equivalence difference between CO<sub>2</sub> biomass combustion emissions and CO<sub>2</sub> absorption  
15 during growth of plants was considered as it is commonly accepted. Minimum selling price of  
16 GA and total CO<sub>2</sub> emission were estimated without the use of natural gas and then purchasing  
17 the required net electricity for the plant. This resulted decrease in operating cost and therefore  
18 minimum selling price of glucaric acid decreased by 5 % in route 1 and route 2 and with  
19 decrease in total CO<sub>2</sub>eq emissions also by 3 % in both production routes 1 and 2. However, total  
20 CO<sub>2</sub>eq emission for electricity purchased could not be accounted and thus for accurate estimation  
21 of CO<sub>2</sub>eq emission use of supplemental natural gas along with combustion of solid biomass  
22 fractions were considered in electricity generation.

## 1 *Sensitivity analysis for sustainable production of GA*

2 A sensitivity analysis has been performed to determine the economic and environmental  
3 sustainability of manufacturing bio-based GA via both production routes with consideration of  
4 the effect of key economic and operational parameters. This was done by varying one parameter  
5 at a time and estimation of the effect on the minimum selling price of glucaric acid. The  
6 considered variation in parameters from the base case condition are given in Table 8. For both  
7 Route 1 and Route 2, the effect of project contingency, income tax rate, fixed capital investment,  
8 feedstock cost and recyclability of acetonitrile solvent on the minimum selling price of GA are  
9 shown in Figure 3 (a) and (b), respectively. With increase in feedstock cost from 88 \$/tonne to  
10 97 \$/tonne, the minimum selling price of GA increases by 2.46 % in Route1 and 2.0 % in Route  
11 2. Whereas, an increase in the fixed capital investment by 30%, causes the minimum selling  
12 price of GA to increase by 14 % in Route 1 and 2. With 5% decrease in recyclability of  
13 acetonitrile solvent, the minimum selling price of GA increases by 17% in Route 1 and 10% in  
14 Route 2. Further detailed investigation of highly uncertain parameters is discussed below which  
15 affect the economic and environmental viability of both routes.

### 16 i) *Heterogeneous Catalyst deactivation and Pt/C catalyst cost*

17 The heterogeneous and homogeneous oxidation routes appear to be competitive in terms of  
18 overall GA yield and selling price. For both routes, the glucose oxidation step has a significant  
19 impact on the techno-economic and life cycle assessment of bio-derived GA. In Route 1, the  
20 activity and robustness of the supported platinum catalyst is a key consideration in the glucose  
21 oxidation step (Boussie et al., 2013; Lee et al., 2016; Wenkin et al., 1997a). At industrial scale,  
22 one of the major problems related to heterogeneous catalysis is loss of catalyst activity with time  
23 on stream. A number of studies have reported aerobic glucose oxidation using supported

1 precious metal catalysts in combination with co-catalysts such as Bi, Sn and Te, which can  
2 prevent oxidative deactivation of the noble metal (Abadi and van Bekkum, 1995; Dirkx et al.,  
3 1977; Jin et al., 2015; Shaner et al., 2016; Sheldon and van Bekkum, 2007; Wenkin et al., 1997b,  
4 1996). Other issues such as leaching of the precious metal component can also impact on catalyst  
5 lifetime. Catalyst deactivation can also result from the co-products such as HMF and furfural  
6 formed during saccharification of the corn stover. Recent papers by Derrien et al. have  
7 demonstrated that the presence of furanic compounds in the feed strongly reduces the catalytic  
8 glucose oxidation reaction rate (Derrien et al., 2017, 2016). Thus, a sensitivity analysis has been  
9 performed on the minimum selling price of the GA by consideration of major uncertainty  
10 parameters such as a decrease in GA yield due to catalyst deactivation.

11 A 5% decrease in GA yield/annum relative to the base case 60% yield has been investigated.  
12 To maintain catalyst activity, regeneration of the catalyst could be performed by a thermal  
13 regeneration processes using water with the resultant wastewater stream being treated in the  
14 WWT plant in A600. Nevertheless, in the current process model the catalyst regeneration step  
15 was not defined as more experimental data is required on suitable regeneration procedures.  
16 Figure 3(a) shows that with a decrease in GA yield from 60% to 55%, the minimum selling price  
17 of GA increases by 7%. The cost of the Pt/C catalyst also significantly affects the minimum  
18 selling price of GA. Assuming a change in discount % of the catalyst price, changes the total cost  
19 of the Pt/C catalyst. For example, by decreasing the cost from 5237 \$/kg to 2619 \$/kg, the  
20 minimum selling price of GA decreases by 4%. This preliminary analysis shows that fixed  
21 capital investment including catalyst cost is the most significant variable with the potential to  
22 significantly affect the economic performance of Route 1 at industrial scale. Given the abundant  
23 availability of biomass and a Pt/C catalyst with a reasonably high operating stability and a cost

1 appropriate for bulk quantity, Route 1 could be applicable for the large-scale production of GA.  
2 However, for more accurate TEA analysis, further studies of catalytic glucose oxidation with the  
3 real feedstock are required.

#### 4 *ii) C<sub>5</sub> sugars as by-product*

5 In lignocellulosic biomass conversion, a mixture of sugars stream, ~38000 kg/hr, is generated  
6 in both routes considered here. This is one of the main by-products of the present process which  
7 was not assigned any economic value in estimating MSP of GA. Direct selling of this stream to  
8 market or valorisation by conversion into high value chemicals would further improve the  
9 overall process economics. Figure 3 (a) and (b) shows with change in the market selling price of  
10 sugars mixture from 0.1 \$/kg to 0.2 \$/kg, minimum selling price of GA varies from 2 \$/kg to 1.5  
11 \$/kg in Route 1 and 2.2 to 1.6 \$/kg in route 2, respectively.

#### 12 *iii) Recovery of nitric acid reagent*

13 In Route 2, the use of inexpensive high strength nitric acid reagent requires effective  
14 temperature control of the glucose oxidation process. Smith et al. have reported nitric acid  
15 oxidation performed at a milder reaction temperature (40°C) and pressure (2 bar) and also  
16 proposed downstream methods for removal of nitric acid after oxidation (Smith et al., 2012). In  
17 our model we assumed that 98% HNO<sub>3</sub> is recycled back to the reactor. It was observed that a  
18 slight variation in HNO<sub>3</sub> recyclability could affect the required HNO<sub>3</sub> make-up and consequently  
19 the total CO<sub>2</sub> emissions of the process. The sensitivity analysis shown in Figure 4 indicated 11 %  
20 increase in the CO<sub>2</sub> emissions, i.e. from 2150 kg CO<sub>2</sub>eq to 2378 kg CO<sub>2</sub>eq per tonne of GA,  
21 when the HNO<sub>3</sub> recyclability was reduced by 3% from 98% to 95%. With a further 5% reduction  
22 in HNO<sub>3</sub> recyclability, the CO<sub>2</sub> emissions increased by 31%, reaching 2824 kg CO<sub>2</sub> eq/tonne of

1 GA. Thus, efficient unit operations in nitric acid recovery are a key consideration for scale up of  
2 Route 2.

3 One of the advantages of glucose oxidation using heterogeneous catalysis in the presence of  
4 base that it could reduce leaching of precious metal catalyst and the separation of other salts by  
5 employing a simple crystallisation step. Additionally, it would reduce the unit operation of  
6 neutralisation after the glucose oxidation step. These findings recommend glucose oxidation as a  
7 significant important step to decide the overall sustainability of bio-based GA production.  
8 Therefore, we need either a selective glucose oxidation process restricting formation of GA only  
9 or the potential method for the separation of by-products generated during glucose oxidation.

#### 10 *General remarks*

11 The current investigation shows that both production routes, heterogeneous oxidation (Route  
12 1) and homogeneous oxidation (Route 2), have the potential to produce GA from biomass such  
13 as corn stover at large scale. The pure GA obtained in this process model could serve as the  
14 feedstock for synthesis of adipic acid and a range of other products. However, it is necessary to  
15 perform systematic TEA and LCA studies of these additional processes before translating the  
16 laboratory scale process to industrial scale. The production scale also dictates potential  
17 applications for the highly pure GA produced and thereby which of Routes 1 or 2 are more  
18 favorable. Route 2 is favored at a small scale due to ready availability of HNO<sub>3</sub> and relatively  
19 efficient temperature control. In this way Route 2 would be preferable for synthesis of GA for  
20 use in detergents or for application such as an alternative to toxic-phosphorous based corrosion  
21 inhibitors. The large scale of global demand for adipic acid would necessitate large volumes of  
22 GA under which circumstances catalytic glucose oxidation via Route 1 would be favored.



1 This study shows the comparative assessment of these two routes whilst also integrating GA  
2 purification into the process model. The formation of pure GA as a dry, crystalline solid could  
3 reduce product transportation costs and potentially extend its shelf life. Further decreases in  
4 transportation costs and CO<sub>2</sub> emissions could also be achieved by locating GA production in  
5 close proximity to the biomass feedstock source. In contrast, in manufacturing adipic acid from  
6 GA via hydrodeoxygenation (HDO), it may be more economical to situate the hydrogenation  
7 plant close to the hydrogen source. This approach would affect the overall supply chain of adipic  
8 acid production. Indeed, continuously supplying hydrogen to the HDO process would  
9 circumvent the costs related to large scale hydrogen storage, whilst also reducing the associated  
10 supply chain CO<sub>2</sub> emissions. Well considered sourcing of the input hydrogen stream could also  
11 lead to significant improvements in economic and environmental aspects of the process. In this  
12 paper, we have reported TEA and LCA analyses for GA production. In the future, it would be  
13 beneficial to carry out a combined study which also integrates the production and distribution of  
14 hydrogen into a flowsheet for large scale production of commodity chemicals in an economically  
15 and environmentally benign manner.

## 16 **Conclusion**

17 The production of pure, crystalline GA from corn stover, which is an abundant and cheap  
18 source of biomass, has been investigated. Two routes for oxidation of glucose have been  
19 evaluated and compared: via either nitric acid or catalytic glucose oxidation. TEA and LCA  
20 assessments of the designed processes demonstrate the suitability of both in producing GA on a  
21 commercial scale. Based on ion-exchange adsorptive separation and azeotropic evaporation, 98  
22 % pure GA was recovered in solid form. TEA analysis shows due to higher GA yield in  
23 heterogeneously catalyzed aerobic glucose oxidation of *ca.* 183 kg/tonne of biomass is

1 economically and environmentally more sustainable route to GA production than nitric acid-  
2 mediated glucose oxidation, as the latter incurs high GHG emissions associated with nitric acid  
3 production. Both routes could be developed for commercial production of GA. However, the  
4 commercial viability would be improved by valorization of the by-product streams, for example  
5 utilization of the waste sugars from enzyme hydrolysis, and the efficient separation of the  
6 glucarate salt from the by-product salts. For the catalytic oxidation route, a stable catalyst  
7 preferably with improved yield of glucaric acid remains a key issue. For homogeneous glucose  
8 oxidation, nitric acid recovery needs to be addressed to make a more environmentally friendly  
9 process. The promising GA production routes investigated here could be further extended to  
10 consider downstream manufacturing of either small scale products such as pharmaceuticals or  
11 large-scale commodity chemicals such as adipic acid.

12

### 13 **Acknowledgement**

14 This work was performed with financial support from the EPSRC (UK) under grant  
15 EP/K014749/1.

16 **Supporting Information:** Additional information as noted in text is available in Supporting  
17 Information.

### 18 **References:**

19 Abbadi, A., van Bekkum, H., 1995. Effect of pH in the Pt-catalyzed oxidation of d-glucose to d-  
20 gluconic acid. *J. Mol. Catal. A Chem.* 97, 111–118.

21 Armstrong, R.D., Kariuki, B.M., Knight, D.W., Hutchings, G.J., 2017. How to Synthesise High

1 Purity, Crystalline d-Glucaric Acid Selectively. *European J. Org. Chem.* 2017, 6811–6814.  
2 <https://doi.org/10.1002/ejoc.201701343>

3 Besson, M., Gallezot, P., Pinel, C., 2014. Conversion of Biomass into Chemicals over Metal  
4 Catalysts. *Chem. Rev.* 114, 1827–1870. <https://doi.org/10.1021/cr4002269>

5 Bidy, M.J., Scarlata, C., Kinchin, C., 2016. Chemicals from Biomass: A Market Assessment of  
6 Bioproducts with Near-Term Potential NREL/TP-5100-65509.

7 Bin, D., Wang, H., Li, J., Wang, H., Yin, Z., Kang, J., He, B., Li, Z., 2014. Controllable  
8 oxidation of glucose to gluconic acid and glucaric acid using an electrocatalytic reactor.  
9 *Electrochim. Acta* 130, 170–178.  
10 <https://doi.org/https://doi.org/10.1016/j.electacta.2014.02.128>

11 Boussie, T.R., Diamond, G.M., Dias, E., Murphy, V., 2016. Synthesis of Adipic Acid Starting  
12 from Renewable Raw Materials. *Chem. Fuels from Bio-Based Build. Blocks*, Wiley Online  
13 Books. <https://doi.org/doi:10.1002/9783527698202.ch6>

14 Boussie, T.R., Dias, E.L., Fresco, Z.M., Murphy, V.J., 2013. Production of adipic acid and  
15 derivatives from carbohydrate-containing materials. US8501989B2.

16 Bozell, J.J., Petersen, G.R., 2010. Technology development for the production of biobased  
17 products from biorefinery carbohydrates—the US Department of Energy’s “Top 10”  
18 revisited. *Green Chem.* 12, 539–554. <https://doi.org/10.1039/B922014C>

19 Brown, J.M., Manley-Harris, M., Field, R.J., Kiely, D.E., 2007. An NMR Study of the  
20 Equilibration of d-Glucaric Acid with Lactone Forms in Aqueous Acid Solutions. *J.*

1 Carbohydr. Chem. 26, 455–467. <https://doi.org/10.1080/07328300701787172>

2 Brown, T., Florin, N., Fennell, P., 2012. Briefing Paper No. 7: Reducing CO2 emissions from  
3 heavy industry: a review of technologies and considerations for policy makers, Grantham  
4 Institute for Climate Change, Imperial College London. Briefing Papers 1–32.

5 CEPCI, 2017, The chemical engineering plant cost index (CEPCI), 2017.

6 Chen, K., Luo, G., Lei, Z., Zhang, Z., Zhang, S., Chen, J., 2018. Chromatographic separation of  
7 glucose, xylose and arabinose from lignocellulosic hydrolysates using cation exchange  
8 resin. Sep. Purif. Technol. 195, 288–294.  
9 <https://doi.org/https://doi.org/10.1016/j.seppur.2017.12.030>

10 Comotti, M., Pina, C. Della, Rossi, M., 2006. Mono- and bimetallic catalysts for glucose  
11 oxidation. J. Mol. Catal. A Chem. 251, 89–92.  
12 <https://doi.org/https://doi.org/10.1016/j.molcata.2006.02.014>

13 Deller, K., Krause, H., Peldszus, E., Despeyroux, B., 1992. Method for preparation of gluconic  
14 acid by catalytic oxidation of glucose. US5132452A.

15 Derrien, E., Marion, P., Pinel, C., Besson, M., 2016. Influence of Residues Contained in  
16 Softwood Hemicellulose Hydrolysates on the Catalytic Oxidation of Glucose to Glucarate  
17 in Alkaline Aqueous Solution. Org. Process Res. Dev. 20, 1265–1275.  
18 <https://doi.org/10.1021/acs.oprd.6b00095>

19 Derrien, E., Mounquengui-Diallo, M., Perret, N., Marion, P., Pinel, C., Besson, M., 2017.  
20 Aerobic Oxidation of Glucose to Glucaric Acid under Alkaline-Free Conditions: Au-Based

1 Bimetallic Catalysts and the Effect of Residues in a Hemicellulose Hydrolysate. *Ind. Eng.*  
2 *Chem. Res.* 56, 13175–13189. <https://doi.org/10.1021/acs.iecr.7b01571>

3 Diamond, G.M., Dias, E.L., Archer, R.H., Murphy, V.J., Boussie, T.R., 2016. Preparation and  
4 separation of a dicarboxylic acid-containing mixture using a dicarboxylate form of an anion  
5 exchange chromatography resin.

6 Dirkx, J.M.H., van der Baan, H.S., van den Broen, J.M.A.J.J., 1977. The preparation of D-  
7 glucaric acid by the oxidation of D-gluconic acid catalysed by platinum on carbon.  
8 *Carbohydr. Res.* 59, 63–72. [https://doi.org/https://doi.org/10.1016/S0008-6215\(00\)83292-9](https://doi.org/https://doi.org/10.1016/S0008-6215(00)83292-9)

9 EPA, 2017. Inventory U.S. Greenhouse Gas Emissions and Sinks 1990-2015. United States  
10 Environ. Prot. Agency Washington, D.C. EPA 430-P-17-001 EPA.

11 Fernando, S., Adhikari, S., Chandrapal, C., Murali, N., 2006. Biorefineries: Current Status,  
12 Challenges, and Future Direction. *Energy & Fuels* 20, 1727–1737.  
13 <https://doi.org/10.1021/ef060097w>

14 Fishedick, M., Roy, J., Abdel-Aziz, A., Acquaye, A., Allwood, J.M.M., Ceron, J. P., Geng, Y.,  
15 Kheshgi, H., Lanza, A., Perczyk, D., Price, L., Santalla, E., Sheinbaum, C., Tanaka, C.,  
16 2014. Industry. In: *Climate Change 2014 (IPCC 2014): Mitigation of Climate Change.*  
17 *Contribution of Working Group III to the Fifth Assessment Report of the Intergovernmental*  
18 *Panel on Climate Change.* Cambridge University Press, Cambridge, United Kingdom and  
19 New York, NY, USA.

20 Glucaric Acid Market Analysis By Product (Pure Glucaric Acid, Potassium Sodium D-glucarate,  
21 D-Glucaric Acid-1,4-lactone), By Application (Food Ingredients, Detergents, Corrosion

1 Inhibitors), & Segment Forecasts, 2014 - 2025. GVR-1-68038-853-4, 2017. URL  
2 <https://www.grandviewresearch.com/industry-analysis/glucaric-acid-market>

3 Gupta, A., Hicks, M.A., Manchester, S.P., Prather, K.L.J., 2016. Porting the synthetic D-glucaric  
4 acid pathway from *Escherichia coli* to *Saccharomyces cerevisiae*. *Biotechnol. J.* 11, 1201–  
5 1208. <https://doi.org/10.1002/biot.201500563>

6 Han, J., Sen, S.M., Alonso, D.M., Dumesic, J.A., Maravelias, C.T., 2014. A strategy for the  
7 simultaneous catalytic conversion of hemicellulose and cellulose from lignocellulosic  
8 biomass to liquid transportation fuels, *Green Chem.* <https://doi.org/10.1039/C3GC41511B>

9 Humbird, D., Davis, R.E., Tao, L., Kinchin, C.M., Hsu, D.D., Aden, A., Schoen, P., Lukas, J.,  
10 Olthof, B., Worley, M., Sexton, D., Dudgeon, D., 2011. *Process Design and Economics for*  
11 *Biochemical Conversion of Lignocellulosic Biomass to Ethanol*. National Renewable  
12 Energy Laboratory, Technical Report NREL/TP-5100-47764.

13 IEA, 2008. International Energy Agency (IEA) Energy technology perspective. Scenario and  
14 strategies to 2050, *Strategies*.

15 Jin, X., Zhao, M., Shen, J., Yan, W., He, L., Thapa, P.S., Ren, S., Subramaniam, B., Chaudhari,  
16 R. V, 2015. Exceptional performance of bimetallic Pt<sub>1</sub>Cu<sub>3</sub>/TiO<sub>2</sub> nanocatalysts for  
17 oxidation of gluconic acid and glucose with O<sub>2</sub> to glucaric acid. *J. Catal.* 330, 323–329.  
18 <https://doi.org/https://doi.org/10.1016/j.jcat.2015.05.018>

19 Joback, K.G., Reid, R.C., 1987. Estimation of pure-component properties from group-  
20 contributions. *Chem. Eng. Commun.* 57, 233–243.  
21 <https://doi.org/10.1080/00986448708960487>

1 Johnson Matthey R&D News, Johnson Matthey and Rennovia Announce License Agreement  
2 with ADM for Glucaric Acid Production Technology, 2017. URL  
3 [https://matthey.com/news/2017/jm-and-rennovia-announce-licence-agreement-with-adm-](https://matthey.com/news/2017/jm-and-rennovia-announce-licence-agreement-with-adm-for-glucaric-acid-production-technology)  
4 [for-glucaric-acid-production-technology](https://matthey.com/news/2017/jm-and-rennovia-announce-licence-agreement-with-adm-for-glucaric-acid-production-technology)

5 Rennovia Press Release, Johnson Matthey Process Technologies and Rennovia Announce On  
6 Time Start-up of Mini-Plant for Bio-Based Glucaric Acid Production Using Jointly  
7 Developed Technology. 2015, 2015. URL [https://www.rennovia.com/wp-](https://www.rennovia.com/wp-content/uploads/2015/07/Johnson-Matthey-Process-Technologies-and-Rennovia-Announce-On-Time-Start-of-Mini-Plant-for-Bio-Based-Glucaric-Acid-Production-July-16th-2015.pdf)  
8 [content/uploads/2015/07/Johnson-Matthey-Process-Technologies-and-Rennovia-Announce-](https://www.rennovia.com/wp-content/uploads/2015/07/Johnson-Matthey-Process-Technologies-and-Rennovia-Announce-On-Time-Start-of-Mini-Plant-for-Bio-Based-Glucaric-Acid-Production-July-16th-2015.pdf)  
9 [On-Time-Start-of-Mini-Plant-for-Bio-Based-Glucaric-Acid-Production-July-16th-2015.pdf](https://www.rennovia.com/wp-content/uploads/2015/07/Johnson-Matthey-Process-Technologies-and-Rennovia-Announce-On-Time-Start-of-Mini-Plant-for-Bio-Based-Glucaric-Acid-Production-July-16th-2015.pdf)

10 Lampe, J.W., Li, S.S., Potter, J.D., King, I.B., 2002. Serum beta-glucuronidase activity is  
11 inversely associated with plant-food intakes in humans. *J. Nutr.* 132, 1341–1344.  
12 <https://doi.org/10.1093/jn/132.6.1341>

13 Lee, J., Saha, B., Vlachos, D.G., 2016. Pt catalysts for efficient aerobic oxidation of glucose to  
14 glucaric acid in water. *Green Chem.* 18, 3815–3822. <https://doi.org/10.1039/C6GC00460A>

15 Luterbacher, J.S., Rand, J.M., Alonso, D.M., Han, J., Youngquist, J.T., Maravelias, C.T., Pflieger,  
16 B.F., Dumesic, J.A., 2014. Nonenzymatic sugar production from biomass using biomass-  
17 derived gamma-valerolactone. *Science* 343, 277–280.  
18 <https://doi.org/10.1126/science.1246748>

19 Miedziak, P.J., Alshammari, H., Kondrat, S.A., Clarke, T.J., Davies, T.E., Morad, M., Morgan,  
20 D.J., Willock, D.J., Knight, D.W., Taylor, S.H., Hutchings, G.J., 2014. Base-free glucose  
21 oxidation using air with supported gold catalysts. *Green Chem.* 16, 3132–3141.

1        <https://doi.org/10.1039/C4GC00087K>

2        Millar, G.J., Couperthwaite, S.J., Leung, C.W., 2015. An examination of isotherm generation:  
3        Impact of bottle-point method upon potassium ion exchange with strong acid cation resin.  
4        Sep. Purif. Technol. 141, 366–377.  
5        <https://doi.org/https://doi.org/10.1016/j.seppur.2014.12.024>

6        Mussatto, S.I., Dragone, G.M., 2016. Chapter 1 Biomass Pretreatment, Biorefineries, and  
7        Potential Products for a Bioeconomy Development. In Biomass Fractionation Technologies  
8        for a Lignocellulosic Feedstock Based Biorefinery, Biomass Fractionation Technologies for  
9        a Lignocellulosic Feedstock Based Biorefinery. Elsevier, Amsterdam.  
10       <https://doi.org/https://doi.org/10.1016/B978-0-12-802323-5.00001-3>

11       NREL 2017 biochemical sugar model (BC1707A), 2017. URL  
12       [https://www.nrel.gov/extranet/biorefinery/aspens-models/downloads/bc1707a/sugar-model-](https://www.nrel.gov/extranet/biorefinery/aspens-models/downloads/bc1707a/sugar-model-readme.pdf)  
13       [readme.pdf](https://www.nrel.gov/extranet/biorefinery/aspens-models/downloads/bc1707a/sugar-model-readme.pdf)

14       Peters, M., Timmerhaus, K., West, R., 2003. Plant Design and Economics for Chemical  
15       Engineers, 5 ed. McGraw-Hill Education.

16       Sigma Aldrich: Platinum on carbon, 5 wt. % loading, matrix activated carbon support.  
17       <https://www.sigmaaldrich.com/catalog/product/aldrich/205931?lang=en&region=GB>  
18       (accessed August 23, 2018).

19       Sen, S.M., Alonso, D.M., Wettstein, S.G., Gürbüz, E.I., Henao, C.A., Dumesic, J.A., Maravelias,  
20       C.T., 2012. A sulfuric acid management strategy for the production of liquid hydrocarbon  
21       fuels via catalytic conversion of biomass-derived levulinic acid. Energy Environ. Sci. 5,



1 9690. <https://doi.org/10.1039/c2ee22526c>

2 Shaner, M.R., Atwater, H.A., Lewis, N.S., McFarland, E.W., 2016. A comparative  
3 technoeconomic analysis of renewable hydrogen production using solar energy. *Energy*  
4 *Environ. Sci.* 9, 2354–2371. <https://doi.org/10.1039/C5EE02573G>

5 Sheldon, R.A., van Bekkum, H., 2007. Oxidation. In *Fine Chemicals through Heterogeneous*  
6 *Catalysis*, in: Wiley Online Books. <https://doi.org/10.1002/9783527612963.ch09>

7 Smith, T.N., Hash, K., Davey, C.-L., Mills, H., Williams, H., Kiely, D.E., 2012. Modifications in  
8 the nitric acid oxidation of d-glucose. *Carbohydr. Res.* 350, 6–13.  
9 <https://doi.org/https://doi.org/10.1016/j.carres.2011.12.024>

10 Sugar Price, 2019. URL <https://markets.businessinsider.com/commodities/sugar-price>. (accessed  
11 February 15, 2019)

12 Thaore, V., Chadwick, D., Shah, N., 2018. Sustainable production of chemical intermediates for  
13 nylon manufacture: A techno-economic analysis for renewable production of caprolactone.  
14 *Chem. Eng. Res. Des.* 135, 140–152.  
15 <https://doi.org/https://doi.org/10.1016/j.cherd.2018.05.026>

16 Van Duuren, J.B.J.H., Wittmann, C., 2014. First and Second Generation Production of Bio-  
17 Adipic Acid. In *Bioprocessing of Renewable Resources to Commodity Bioproducts*, Wiley  
18 Online Books. John Wiley & Sons. <https://doi.org/doi:10.1002/9781118845394.ch19>

19 Vasiliu, M., Guynn, K., Dixon, D.A., 2011. Prediction of the Thermodynamic Properties of Key  
20 Products and Intermediates from Biomass. *J. Phys. Chem. C* 115, 15686–15702.

- 1        <https://doi.org/10.1021/jp204243m>
- 2        Walaszek, Z., 1990. Potential use of d-glucaric acid derivatives in cancer prevention. *Cancer*  
3        *Lett.* 54, 1–8. [https://doi.org/https://doi.org/10.1016/0304-3835\(90\)90083-A](https://doi.org/https://doi.org/10.1016/0304-3835(90)90083-A)
- 4        Walaszek, Z., Szemraj, J., Hanausek, M., Adams, A.K., Sherman, U., 1996. d-Glucaric acid  
5        content of various fruits and vegetables and cholesterol-lowering effects of dietary d-  
6        glucarate in the rat. *Nutr. Res.* 16, 673–681. [https://doi.org/https://doi.org/10.1016/0271-](https://doi.org/https://doi.org/10.1016/0271-5317(96)00045-0)  
7        [5317\(96\)00045-0](https://doi.org/https://doi.org/10.1016/0271-5317(96)00045-0)
- 8        Wenkin, M., Renard, C., Ruiz, P., Delmon, B., Devillers, M., 1997a. Promoting effects of  
9        bismuth in carbon-supported bimetallic Pd-Bi catalysts for the selective oxidation of  
10        glucose to gluconic acid. In *Studies in Surface Science and Catalysis*. Elsevier.  
11        [https://doi.org/https://doi.org/10.1016/S0167-2991\(97\)81013-0](https://doi.org/https://doi.org/10.1016/S0167-2991(97)81013-0)
- 12        Wenkin, M., Renard, C., Ruiz, P., Delmon, B., Devillers, M., 1997b. On the role of bismuth-  
13        based alloys in carbon-supported bimetallic Bi-Pd catalysts for the selective oxidation of  
14        gluconic acid. In *Studies in Surface Science and Catalysis*, in: Blaser, H.U., Baiker, A.,  
15        Prins, R. (Eds.), Elsevier, pp. 391–398. [https://doi.org/https://doi.org/10.1016/S0167-](https://doi.org/https://doi.org/10.1016/S0167-2991(97)80929-9)  
16        [2991\(97\)80929-9](https://doi.org/https://doi.org/10.1016/S0167-2991(97)80929-9)
- 17        Wenkin, M., Touillaux, R., Ruiz, P., Delmon, B., Devillers, M., 1996. Influence of metallic  
18        precursors on the properties of carbon-supported bismuth-promoted palladium catalysts for  
19        the selective oxidation of glucose to gluconic acid. *Appl. Catal. A Gen.* 148, 181–199.  
20        [https://doi.org/https://doi.org/10.1016/S0926-860X\(96\)00231-1](https://doi.org/https://doi.org/10.1016/S0926-860X(96)00231-1)
- 21        Werpy, T., Petersen, G., 2004. *Top Value Added Chemicals from Biomass Volume I — Results*

1 of Screening for Potential Candidates from Sugars and Synthesis Gas Top Value Added  
2 Chemicals From Biomass Volume I : Results of Screening for Potential Candidates: US  
3 Department of Energy Energy Efficiency and Renewable Energy: 76 pp.  
4 <https://doi.org/10.2172/15008859>

5 Yuan, W., Ding, R.-H., Ge, H., Zhu, P.-L., Ma, S.-S., Zhang, B., Song, X.-M., 2017. Solid-phase  
6 extraction of d-glucaric acid from aqueous solution. *Sep. Purif. Technol.* 175, 352–357.  
7 <https://doi.org/https://doi.org/10.1016/j.seppur.2016.11.060>

8

1 **List of Tables**

2 **Table 1:** Process areas in glucaric acid production process model (ASPEN process  
3 flowsheet)

4 **Table 2:** Input streams material balance for glucaric acid production routes

5 **Table 3:** The equipment cost and electricity required by each process area in the glucaric  
6 acid production process model

7 **Table 4:** Total capital investment for bio-based glucaric acid production processes

8 **Table 5:** Total production cost estimated for glucaric acid production process model

9 **Table 6(a):** Water balance for glucaric acid production processes

10 **Table 6(b):** Overall water balances for glucaric acid production plants

11 **Table 7:** Cooling utility distribution for glucaric acid production plants

12 **Table 8:** The base case values for Route 1 and Route 2 used for the estimation of minimum  
13 selling price of pure glucaric acid

14 **Figure Captions**

15 **Figure 1:** General Process scheme for conversion of sugars derived from corn stover to pure  
16 glucaric acid

17 **Figure 2:** Total CO<sub>2</sub>eq emissions for bio-derived glucaric acid production processes

18 **Figure 3:** Sensitivity analysis on minimum selling of glucaric acid in **(a)** Route 1 **(b)** Route 2

19 **Figure 4:** Effect of HNO<sub>3</sub> recovery on total CO<sub>2</sub> equivalent emissions per tonne of glucaric  
20 acid in Route 2

21

1

2 **Table 1:** Process areas in glucaric acid production process model (ASPEN process flowsheet)

<b>Process Area</b>	<b>Description</b>
<b>A100</b>	Feedstock handling
<b>A200</b>	Pretreatment with steam and sulphuric acid
<b>A300</b>	Enzymatic Cellulose saccharification
<b>A400</b>	Glucose oxidation Glucaric acid purification
<b>A500</b>	(a) Solid phase extraction of glucaric acid: K-glucarate adsorption (b) Purification of glucaric acid by azeotropic evaporation
<b>A600</b>	Wastewater treatment and Biogas generation in anaerobic and aerobic digester
<b>A700</b>	Storage of raw material and solvent
<b>A800</b>	Combustor
<b>A810</b>	Steam and electricity generation
<b>A900</b>	Process utilities and process plant water distribution

3

4

5

6

7

1

2 **Table 2:** Input streams material balance for glucaric acid production routes

Input stream	Production Route 1		Production Route 2	
	Pt/C-air		HNO <sub>3</sub>	
	Rate (tonne/hr) or (GJ/hr)	Cost US \$/hr	Rate (tonne/hr) or (GJ/hr)	Cost US \$/hr
Biomass	42.44	2994	42.44	2994
H <sub>2</sub> SO <sub>4</sub>	0.81	60	0.81	60
NH <sub>3</sub>	0.82	526	0.82	526
Cellulase	0.24	775	0.24	775
HNO <sub>3</sub>	0.00	0	0.44	126
45% KOH	5.01	1824	3.76	1368
make-up Acetonitrile	0.11	179	0.09	137
Water	124	34.22	120	32.9
Natural gas (energy basis)	194.13	1437	194.13	1437

3

4

1

2 **Table 3:** The equipment cost and electricity required by each process area in the glucaric acid

3 production process model

Process Area	Production Route 1		Production Route 2	
	Total Installed equipment cost (million US \$)	Power required in MW	Total Installed equipment cost (million US \$)	Power required in MW
A100	15.43	0.35	15.45	0.350
A200	20.63	2.71	20.63	3.08
A300	25.27	5.4	25.27	3.93
A400	9.13	15.23	7.42	12
A500				
A600	7.91	0.706	7.81	0.68
A700	6.14	0.029	5.97	0.027
A800	50.89	0.82	52.86	0.86
A900	4.33	2.013	4.3	2.07
<b>Total equipment cost</b>	<b>124.30</b>		<b>124.35</b>	
<b>Total Power generated (MW)</b>		<b>-28.18</b>		<b>-30.158</b>
Surplus Electricity generated (MW)		-1.2		-7.55

4

5

1

2 **Table 4:** Total capital investment for bio-based glucaric acid production processes

	<b>Production Route 1</b>	<b>Production Route 2</b>
<b>Item</b>	<b>Cost (in million US \$)</b>	<b>Cost (in million US \$)</b>
<b>Total installed cost of equipment</b>	<b>124.30</b>	<b>124.35</b>
Warehouse (4 % of ISBL)	2.20	2.13
site development (9% of ISBL)	4.95	4.80
Additional piping (4.5% ISBL)	2.48	2.40
<b>Total direct cost (TDC)</b>	<b>133.93</b>	<b>133.68</b>
Prorateable expenses (10% of TDC)	13.40	13.37
Field expenses (10% of TDC)	13.40	13.37
Home office and construction fee (20% of TDC)	26.79	26.74
Project contingency (40% of TDC)	53.57	53.47
Other costs (10% of TDC)	13.19	13.37
<b>Total Indirect Cost (TIC)</b>	<b>120.57</b>	<b>120.31</b>
<b>Fixed Capital Investment (FCI)</b>	<b>254.46</b>	<b>254.05</b>
Land	2.70	2.70
working capital (5% FCI)	12.72	12.70
Catalyst-oxidation	50.43	-
Ion exchange Resin	0.07	0.05
<b>Total Capital investment (TCI)</b>	<b>320.40</b>	<b>270</b>

3



1

2 **Table 5:** Total production cost estimated for glucaric acid production process model

	<b>Production Route 1</b>	<b>Production Route 2</b>
<b>Cost</b>	<b>value in million US \$/yr</b>	<b>value in million US \$/yr</b>
Utilities	12.36	12.35
Consumables	28.25	25.12
Feedstock	25.15	25.15
Grid +A100 Electricity	-0.62	-3.61
<b>Variable operating cost</b>	<b>65.15</b>	<b>59.01</b>
Maintenance (3% ISBL)	1.38	1.60
Insurance (0.7% FCI)	1.78	1.78
Labor	1.95	1.77
<b>Fixed operating cost</b>	<b>5.11</b>	<b>5.15</b>
<b>Total Product Cost</b>	<b>70.26</b>	<b>64.16</b>

3

4

1

2 **Table 6(a):** Water balance for glucaric acid production processes

	<b>Production route 1</b>	<b>Production route 2</b>
<b>Input streams</b>	H <sub>2</sub> O	H <sub>2</sub> O
	<b>Rate (tonne/hr)</b>	<b>Rate (tonne/hr)</b>
Biomass	8.49	8.47
H <sub>2</sub> SO <sub>4</sub>	0.06	0.06
Enzyme	0.94	0.95
KOH	2.75	2.07
HNO <sub>3</sub>	-	5.40
Dilution	342	230.7
Steam	10.12	15.94
Water generated-in A300	0.74	0.55
<b>Total</b>	<b>364.4</b>	<b>264.15</b>
<i>Table 6(a) continued..</i>	<b>Production route 1</b>	<b>Production route 2</b>
	<b>Rate (tonne/hr)</b>	<b>Rate (tonne/hr)</b>
<b>Output</b>	H <sub>2</sub> O	H <sub>2</sub> O
Vent	12.58	9.13
WWT	196	210
Water consumed during enzyme hydrolysis and A300	2.56	1.13+1.43
Product stream-sugar	22.54	21.97
WWT	-	6.54
Other Product streams	130.95	14.17
<b>Total</b>	<b>364.4</b>	<b>264.14</b>

1

2

3 **Table 6(b):** Overall water balances for glucaric acid production plants

Input	Rate (tonne/hr)	Rate (tonne/hr)
	H <sub>2</sub> O	H <sub>2</sub> O
Biomass	8.74	8.49
H <sub>2</sub> SO <sub>4</sub>	0.04	0.06
Enzyme	0.94	0.95
KOH	2.75	2.07
HNO <sub>3</sub>	-	5.40
Water generated-in A300	0.74	0.55
WWT air intake	0.16	0.16
CIP water	0.15	0.07
Combustion air intake	2.15	3.44
Water generated in combustor	17.63	18.87
water make up	127	27.91
Cooling tower water make up	88.98	88.74
<b>Total</b>	<b>249</b>	<b>156.71</b>

*Table 6(b) continued..*

Output	Rate (tonne/hr)	Rate (tonne/hr)
	H <sub>2</sub> O	H <sub>2</sub> O
Sugars product stream	22.54	21.98
other Product streams	111.15	15.96
Vent	0.218	0.240
water from the combustor stack	30.49	32.97
boiler blowdown vent	1.35	1.43
Water consume in A600 and A810	2.42	2.63
water consumption in enzyme hydrolysis and A300	2.56	1.4+1.1
water evaporated from cooling tower	78.89	78.68
<b>Total</b>	<b>249.62</b>	<b>156.40</b>

1

2

3 **Table 7:** Cooling utility distribution for glucaric acid production plants

<b>Cooling water usage for Process area</b>	<b>Route 1 MW</b>	<b>Route 2 MW</b>
A200	4.34	4.65
A300	6.32	6.30
GA purification	-7.50	-8.24
A800	54	54.22
Evaporator condensation	7.50	7.50
<b>Total cooling utility</b>	<b>64.59</b>	<b>64.42</b>

4

5

1  
2  
3  
4  
5  
6  
7  
8  
9  
10  
11

**Table 8:** The base case values for Route 1 and Route 2 used for the estimation of minimum selling price of pure glucaric acid

<b>Parameters</b>	<b>Base case value</b>	<b>Units</b>
Corn stover biomass cost (79:88:97)	88	\$/tonne
Pt/C catalyst cost (10%: 50%: 75%)	5237 <sup>#</sup>	\$/kg
GA yield (55: 60 %)	60 <sup>#</sup>	%
Acetonitrile recycling (95: 99%)	99	%
Project contingency (10%:40%)	40	%
Fixed capital investment ( $\pm$ 30%)	254	M \$
Income tax rate (25% :35%)	35	%
By-product Sugars cost (0: 0.2)	0	\$/kg

*# For production Route 2, GA yield = 45% using nitric acid reagent for glucose oxidation*

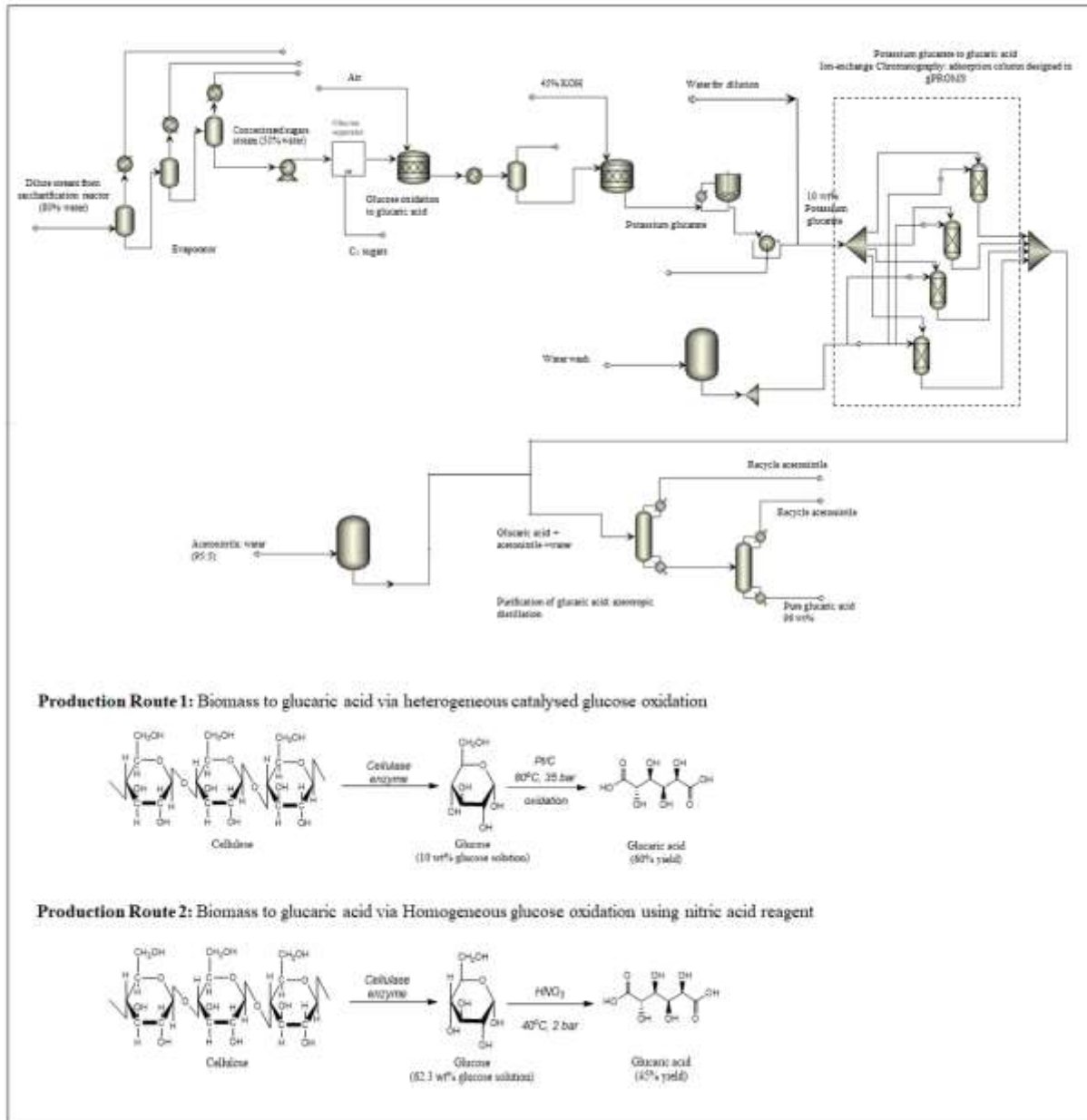

1  
 2 **Figure 1:** General Process scheme for conversion of sugars derived from corn stover to pure  
 3 glucaric acid

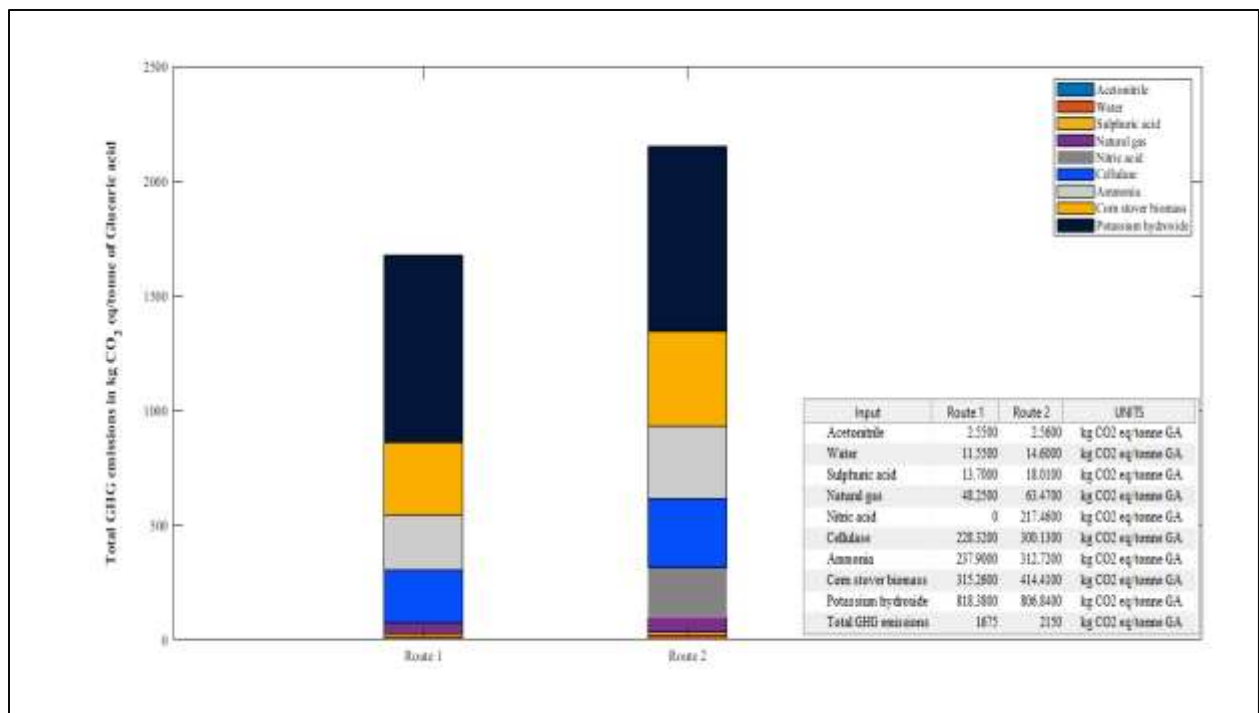

1  
2  
3  
4  
5  
6  
7

**Figure 2:** Total CO<sub>2</sub>eq emissions for bio-derived glucuronic acid production processes via Route 1 and Route 2

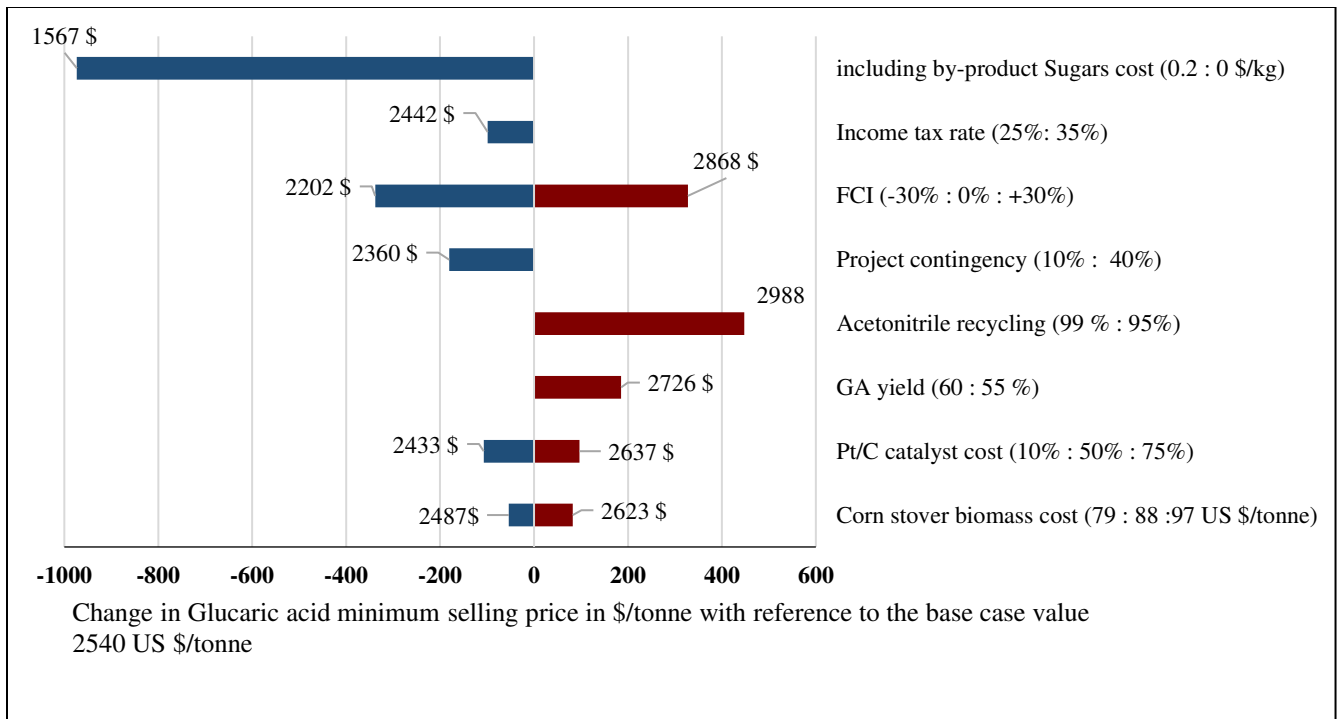

1

2

(a)

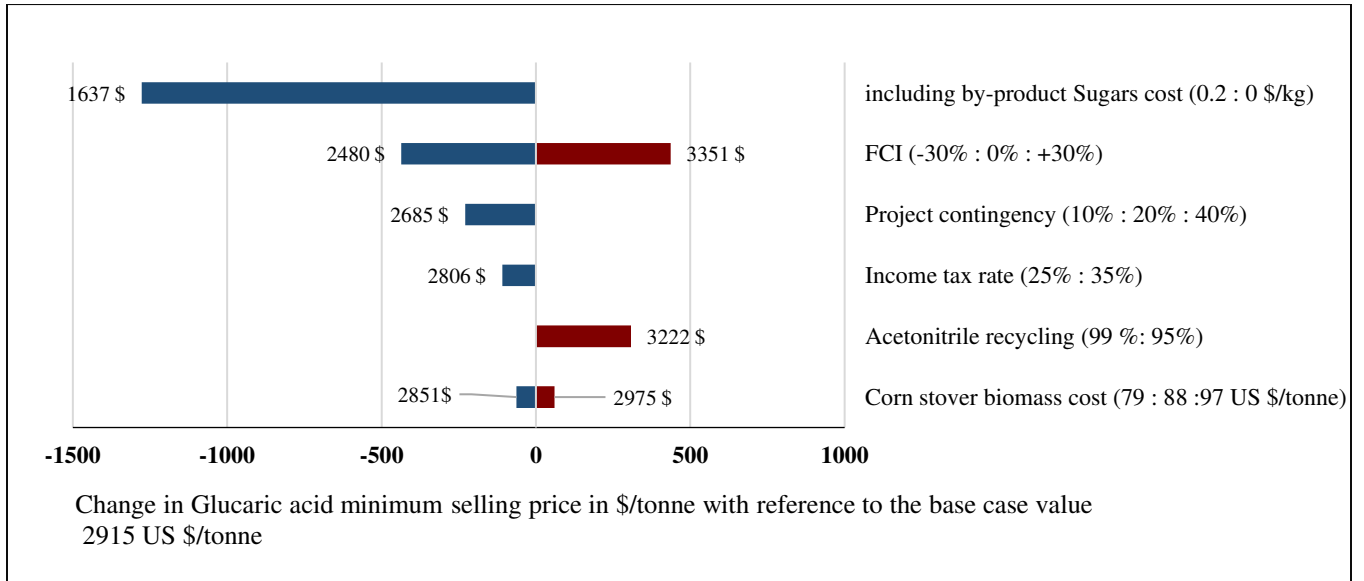

3

4

(b)

5

**Figure 3:** Sensitivity analysis on minimum selling of glucaric acid in (a) Route 1 (b) Route2



1

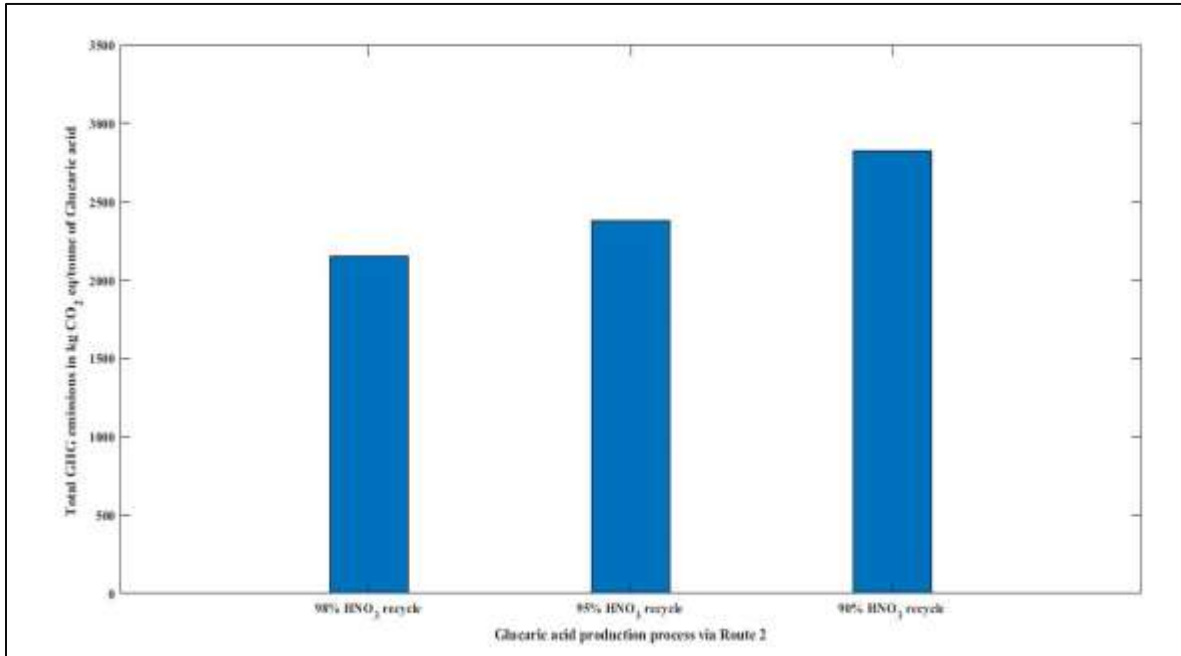

2

3 **Figure 4:** Sensitivity analysis on total CO<sub>2</sub>e emission per tonne of glucaric acid in Route 2

4

5