

Online Research @ Cardiff

This is an Open Access document downloaded from ORCA, Cardiff University's institutional repository: <http://orca.cf.ac.uk/129780/>

This is the author's version of a work that was submitted to / accepted for publication.

Citation for final published version:

Crole, David A., Underhill, Ricci, Edwards, Jennifer K., Shaw, Greg, Freakley, Simon J., Hutchings, Graham J. and Lewis, Richard J. 2020. The direct synthesis of hydrogen peroxide from H₂ and O₂ using Pd-Ni/TiO₂ catalysts. Philosophical Transactions A: Mathematical, Physical and Engineering Sciences 378 (2176) , 20200062. 10.1098/rsta.2020.0062 filefile

Publishers page: <https://doi.org/10.1098/rsta.2020.0062> <<https://doi.org/10.1098/rsta.2020.0062>>

Please note:

Changes made as a result of publishing processes such as copy-editing, formatting and page numbers may not be reflected in this version. For the definitive version of this publication, please refer to the published source. You are advised to consult the publisher's version if you wish to cite this paper.

This version is being made available in accordance with publisher policies. See <http://orca.cf.ac.uk/policies.html> for usage policies. Copyright and moral rights for publications made available in ORCA are retained by the copyright holders.



The Direct Synthesis of Hydrogen Peroxide from H₂ and O₂ Using Pd-Ni/TiO₂ Catalysts.

David A. Crole,^a Ricci Underhill,^a Jennifer K. Edwards,^a Greg Shaw,^a Simon J. Freakley^b
Graham J. Hutchings^a and Richard J. Lewis,^{a*}

^a Cardiff Catalysis Institute, School of Chemistry, Cardiff University, Main Building, Park Place, Cardiff, CF10 3AT, United Kingdom.

^b Department of Chemistry, University of Bath, Claverton Down, Bath BA2 7AY, United Kingdom.

* LewisR27@Cardiff.ac.uk

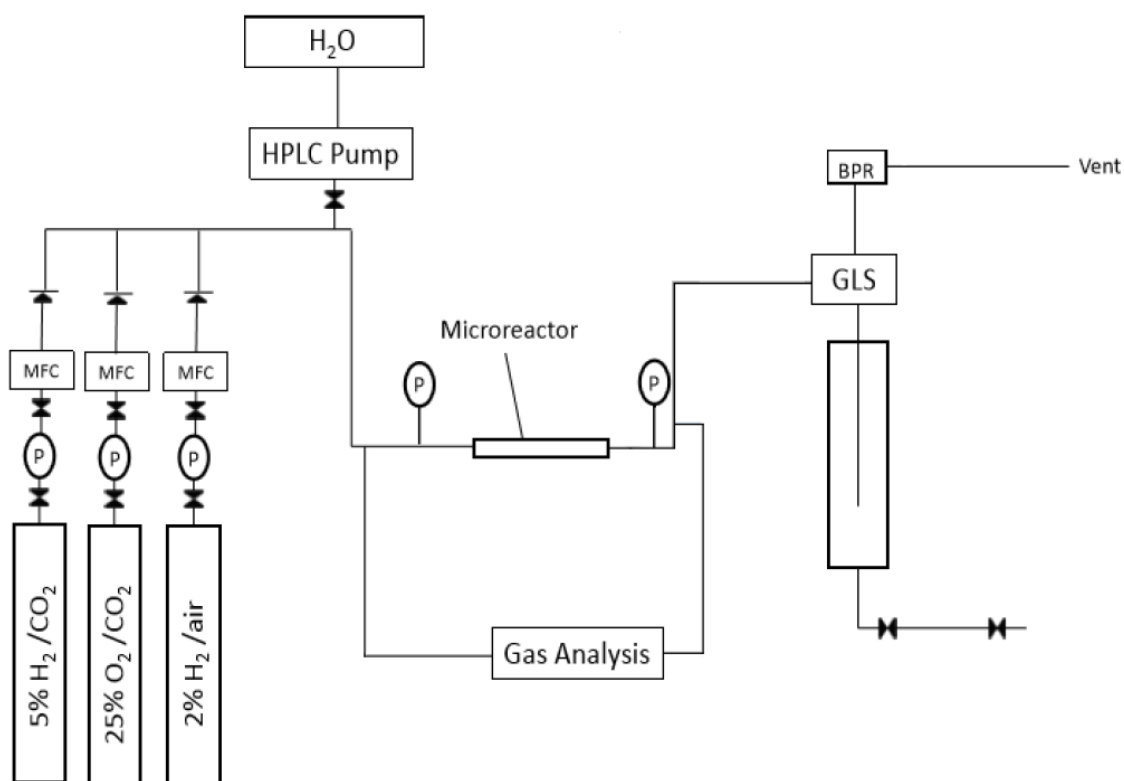

Supplementary Figure 1: Schematic of flow reactor. P = pressure gauge, MFC = mass flow controller, GLS = gas liquid separator, BPR = back pressure regulator.

Supplementary Table 1: Comparison of catalytic activity towards H₂O₂ synthesis and its subsequent degradation, under batch conditions.

Catalyst	H ₂ O ₂ Concentration / ppm	Degradation / %	H ₂ Selectivity / %
0.5%Pd/TiO ₂	133	10	75
0.5%Pd-4.5%Ni/TiO ₂	152	0	97
4.5%Ni/TiO ₂	0	0	-

H₂O₂ direct synthesis reaction conditions: catalyst (0.01 g), H₂O (8.5 g), 5% H₂/CO₂ (420 psi), 25% O₂/CO₂ (160 psi), 0.5 h, 20 °C, 1200 rpm. H₂O₂ degradation reaction conditions: catalyst (0.01 g), H₂O₂ (50 wt. %, 0.68 g), H₂O (7.82 g), 5% H₂/CO₂ (420 psi), 0.5 h, 20 °C, 1200 rpm.

Supplementary Table 2: Leaching of Pd and Sn in 0.5% Pd-4.5% Sn / TiO₂(ORO) catalyst observed via MP-AES over 10 h on-stream in flow reactor.

Time on-stream / h	Leaching of metal from 0.5% Pd-4.5% Sn / TiO ₂ (ORO)	
	Loss of Pd / %	Loss of Sn / %
0.25	B.D.L	B.D.L
0.5	B.D.L	B.D.L
1	B.D.L	B.D.L
2	B.D.L	B.D.L
4	B.D.L	B.D.L
6	B.D.L	B.D.L
8	B.D.L	B.D.L
10	B.D.L	B.D.L

B.D.L: Below Detection Limit.

Reaction conditions: 20 °C, catalyst mass (0.25 g) H₂O liquid flow rate, 1 mLmin⁻¹, 30 bar total pressure, 5%H₂/CO₂ (175 mLmin⁻¹), 25% O₂/CO₂ (35 mLmin⁻¹).