

Graph Machine Learning Approaches to Classifying the Building and Ground Relationship

Architectural 3D Topological Model to Retrieve Similar Architectural
Precedents



Thesis submitted in partial fulfilment of the requirements for the degree of
Doctoral of Philosophy

Cardiff University
Welsh school of architecture

BY

Abdulrahman Ahmed Alymani

October 2022

Acknowledgment

Although this thesis is my own work, it has been influenced by a number of individuals and organisations. It is, therefore, a worthwhile opportunity for me to express my gratitude to those who contributed to the success of this research.

I would like to begin by thanking God for granting me the opportunity to complete this thesis with the effort I have put in.

I would like to express my gratitude to my supervisor, Professor Wassim Jabi, who has provided invaluable and supportive guidance, motivation, and extensive knowledge during my doctoral studies, all of which have contributed to the successful completion of my dissertation. Additionally, I would like to express my gratitude to my second supervisor, Dr Wesley Aelbrecht, and Dr Pdraig Corcoran. My research has been influenced and reoriented by your insightful comments.

I would also like to express my sincere gratitude and respect to everyone who participated in this research and shared their thoughts, opinions, and stories. It is my pleasure to extend my most sincere thanks to the members of my review community who evaluated the annual report; your meaningful comments greatly influenced and reoriented my research to what it is today.

Dr Simon Lannon (Internal Examiner) and Dr Silvio Carta (External Examiner - University of Hertfordshire) deserve my gratitude for their time and efforts. I was honoured to have the opportunity to discuss this work with both. This was an unforgettable moment in my life.

I am also grateful for the editing assistance, late-night feedback sessions and moral support from my classmates and cohort members, especially my office mate Ammar Alammari.

I would be remiss not to mention my family, particularly my parents, spouse, and children. Throughout this process, their belief in me has kept my spirits high and motivated. Furthermore, I would like to thank my dog for providing me with much entertainment and emotional support.

Lastly, I would like to acknowledge and thank my scholarship sponsor, the Saudi Arabia Ministry of Education, for their generous support.

Dedication

The humble effort I made is dedicated to

My beloved Dad and Mom

Your love, encouragement, support and prayers have enabled me to achieve such success and honour

My wonderful parents-in-law

As a second Mum and Dad.

For your belief in me to reach my goals

My wonderful wife, Wegdan

My dearest wife, who leads me through the valley of darkness with the light of hope and support. My appreciation goes to her for allowing me to experience the love, patience, care and encouragement I needed to achieve my goals

My sweet daughters, Wajan and Sadan

For supporting me during my PhD journey and for your patience with me when I was busy.

Both of you have been my best cheerleaders

My lovely brothers

For their continuous support

Graph Machine Learning Approaches to Classifying the Building and Ground Relationship

Architectural 3D Topological Model to Retrieve Similar Architectural Precedents

Abstract

Architects struggle to choose the best form of how the building meets the ground and may benefit from a suggestion based on precedents. A precedent suggestion may help architects decide how the building should meet the ground. Machine learning (ML), as a part of artificial intelligence (AI), can play a role in the following scenario to determine the most appropriate relationship from a set of examples provided by trained architects. A key feature of the system involves its classification of three-dimensional (3D) prototypes of architectural precedent models using a topological graph instead of two-dimensional (2D) images to classify the models. This classified model then predicts and retrieves similar architecture precedents to enable the designer to develop or reconsider their design. The research methodology uses mixed methods research. A qualitative interview validates the taxonomy collected in the literature review and image sorting survey to study the similarity of human classification of the building and ground relationship (BGR). Moreover, the researcher leverages the use of two primary technologies in the development of the BGR tool. First, a software library enhances the representation of 3D models by using non-manifold topology (Topologic). The second phase involves an end-to-end deep graph convolutional neural network (DGCNN). This study employs a two-stage experimental workflow. The first step sees a sizable synthetic database of building relationships and ground topologies created by generative simulation for a 3D prototype of architectural precedents. These topologies then undergo conversion into semantically rich topological dual graphs. Second, the prototype architectural graphs are imported to the DGCNN model for graph classification. This experiment's results show that this approach can recognise architectural forms using more semantically relevant and structured data and that using a unique data set prevents direct comparison. Our experiments have shown that the proposed workflow achieves highly accurate results that align with DGCNN's performance on benchmark graphs. Additionally, the study demonstrates the effectiveness of using different machine learning approaches, such as Deep Graph Library (DGL) and Unsupervised Graph Level Representation Learning (UGLRL). This research demonstrates the potential of AI to help designers identify the topology of architectural solutions and place them within the most relevant architectural canons.

List of Publications

According to the results of this research, the following papers have been published:

1. Alymani, A, Jabi, W, Corcoran, P. (2022-a). Graph Machine Learning Classification Using Architectural 3D Topological Models. *SIMULATION journal*, 5 May 2022. <https://orca.cardiff.ac.uk/id/eprint/151167/1/00375497221105894.pdf>
2. Alymani, Jabi, W, Corcoran, P. (2022-b). Modelling the Relationships between Ground and Buildings Using 3D Architectural Topological Models Utilizing Graph Machine Learning. *The 6th International Symposium Formal Methods in Architectural, ETS Arquitectura, Campus da Zapeteira (A Coruña)*, 24-27 May 2022.
3. Alymani, A, Mujica, A, Jabi, W, Corcoran, P. (2022-c). Classifying Building and Ground Relationships Using Unsupervised Graph-Level Representation Learning. *Design Computing and Cognition'22 Conference University of Strathclyde, Glasgow, Scotland UK*. 4-6 July 2022, pp.339-357. https://orca.cardiff.ac.uk/id/eprint/151063/1/DCC522_10.pdf
4. Alymani, A, Jabi. (2022-d). Graph Machine Learning Classification Using Architectural 3D Topological Models. *Computer-Aided Architectural Design Research in Asia CAADRIA, post-carbon (Online workshop)*, 9 April 2022.
5. Jabi, W, Alymani, A. (2020-a) 'Graph Machine Learning using 3D Topological Models'. *SimAUD '20: Proceedings of the 11th Annual Symposium on Simulation for Architecture and Urban Design (Online)*, 25 - 27 May 2022, pp.427-434. <https://orca.cardiff.ac.uk/id/eprint/131855/1/55.pdf>
6. Alymani, A, Jabi, W, Corcoran, P. (2020-b) 'Machine Learning Methods for Clustering Architectural Precedents: Classifying the relationship between building and ground'. *Anthropologic: Architecture and Fabrication in the cognitive age - Proceedings of the 38th eCAADe Conference - Volume 1*, TU Berlin, Berlin, Germany, 16-18 September 2020, pp. 643-652. https://orca.cardiff.ac.uk/id/eprint/134938/1/ecaade2020_193.pdf
7. Alymani, A. (2019) 'Building and Ground Relationship', *Speaking of Science 2019 Conference, Cardiff University*. https://www.researchgate.net/publication/334199853_Building_and_Ground_Relationship

Table of Content

Acknowledgment	i
Dedication	ii
Abstract	iii
List of Publications	iv
Table of Content	v
List of Figures	xiv
List of Tables	xxiv
CHAPTER ONE: INTRODUCTION	1
1.1. Chapter Overview	2
1.2. Research Motivation	2
1.3. Scope and Focus.....	3
1.4. The Background and Nature of the Research Problem	3
1.4.1. Building and Ground Relationship	3
1.4.2. Building and Ground Relationship Aided by Computational Tools	4
1.5. The Significance and Contributions of the Study.....	5
1.6. Research Aim, Questions and Objectives	7
1.7. Research Design and Methodology	8
1.8. Research Structure and Key Outcomes.....	11
CHAPTER TWO: LITERATURE REVIEW	15
2.1. Chapter Overview	16
Part (A) An Exploration of Building and Ground Relationships	18
2.2. Building and Ground Theories.....	18
2.2.1. Modernism Period	18
2.2.2. Post-war Period	20
2.2.3. Contemporary Period	22
2.3. Key Concepts of Architectural Design and The Built Environment Through "Non-Discrete" Building and Ground Relationships.....	23
2.3.1. Open the Architectural Space to the Surrounding Landscape	23
2.3.2. Integrating Between the Landscape and Architecture	24
2.3.2.1. The Relationship Between the Landscape and Modern Architects	26
2.3.2.2. Landscape-Inspired Projects.....	26

2.3.3. Technology and Bearing Structures.....	27
2.3.4. Term of Topography	27
2.4. A Glance at the Architect’s Way of Reaching the Building and the Ground.....	28
2.5. Toma Berlanda, A Graphic Lexicon of How Buildings Touch the Ground (Building and Ground Relationship Taxonomy)	34
2.5.1. The Main Building and Ground Relationship.....	34
2.5.1.1. Separation Approach.....	34
2.5.1.2. Adherence Approach.....	36
2.5.1.3. Interlock Approach	37
2.5.2. The Building Touches the Ground	38
2.5.2.1. Grounded/Ungrounded.....	38
2.5.2.2. Foundation	39
2.5.2.3. Plinth	39
2.5.2.4. Artificial Ground	40
2.6. Building and Ground Taxonomy.....	40
Part (B) Design Thinking and Architectural Computational Methods	42
2.7. Reviewing Design Models and Processes.....	42
2.7.1. The Analysis Synthesis Model.....	43
2.7.2. The Conjecture Analysis Model	45
2.7.3. The Abduction Model	46
2.7.4. Modular Systems	48
2.7.5. Computational Thinking and Design Process	51
2.7.5.1. A Parametric Design Approach (Thinking Mathematically)	52
2.7.5.2. An Object-Oriented Programming (OOP) Approach (Thinking Algorithmically)	53
2.8. Generative Design Processes	55
2.8.1. Grammar as an Analysis Tool and Generative Design	55
2.8.1.1. Shape Grammars	55
2.8.1.2. Description Grammars	56
2.8.1.3. Discursive Grammars.....	60
2.8.1.4. Application of Shape Grammars in Architecture.....	61
2.8.2. Non-Manifold Topology (NMT).....	63
2.8.2.1. Topologic Toolkit	65

2.8.2.2. Application of Non-Manifold Topology in Architecture	67
2.8.3. Graph Theory	69
2.8.3.1. Application of Graph Theory in Architecture	69
2.9. Artificial Intelligence	71
2.9.1. Machine Learning	72
2.9.1.1. Supervised Machine Learning Algorithm	73
2.9.1.2. Unsupervised Machine Learning Algorithm	73
2.9.1.3. Semi-supervised Machine Learning Algorithm	74
2.9.1.4. Reinforcement Learning	74
2.9.2. Clustering Algorithm (Unsupervised).....	74
2.9.2.1. Centroid Clustering Models.....	75
2.9.2.2. K-Means Cluster Algorithm	75
2.9.2.3. K-Modes Cluster Algorithm	75
2.9.2.4. Gaussian Mixture Models (GMM)	75
2.9.2.5. Applications of Clustering Machine Learning Approaches in Architecture...	76
2.9.3. Deep Learning Neural Network	77
2.9.3.1. The Application of Deep Neural Network in Architecture	80
2.9.4. Graph Neural Network (GNN).....	82
2.9.4.1. Graph Embedding (Graph Representation Learning).....	84
2.9.4.2. Graph Convolutional Neural Networks (GCNN)	87
2.9.4.3. Deep Graph Convolutional Neural Networks (DGCNN)	88
2.9.4.4. Application of the Graph Neural Network in Architecture	89
2.10. Related Work.....	90
2.11. Chapter Summary	103
2.11.1. A Review of Studies Concerning the Relationship Between the Building and the Ground (Table 2.1).....	103
2.11.2. A Review of Studies Using Machine Learning Approaches to Cluster Similar Architectural Style Precedents (Table 2.2)	104
2.11.3. A Review of Studies on the Classification of Architectural Works Using Graph Topological Machine Learning in Architecture Design (Table 2.3)	104
CHAPTER THREE: RESEARCH DESIGN AND METHODOLOGY	106
3.1. Chapter Overview	107
3.2. Research Paradigms and Theoretical Approaches.....	107

3.3. Philosophical Foundations of Mixed Methods Research	108
3.3.1. Positivism Paradigm.....	108
3.3.2. Interpretivism Paradigm	109
3.3.3. Pragmatism Paradigm.....	109
3.3.4. Justification of Using the Philosophical Foundations of Mixed Methods Research	110
3.4. Methodological Approaches and Research Methods/Techniques	110
3.4.1. Quantitative Research	111
3.4.1.1. Simulations and Modelling.....	111
3.4.1.2. Quantitative Surveys	112
3.4.1.3. Correlational Research	113
3.4.2. Qualitative research.....	113
3.4.2.1. Archival Research	113
3.4.2.2. Interviews	114
3.4.2.3. Focus Groups	116
3.4.2.4. Observations.....	116
3.4.2.5. Case Studies.....	116
3.4.3. Experimental Research	117
3.4.3.1. Prototyping.....	117
3.4.3.2. Testing	117
3.4.3.3. Experiments.....	118
3.4.4. Mixed-Method Approach	118
3.4.5. Justification of Using the Mixed-Method Approach in the Research.....	120
3.5. Research Framework.....	121
3.5.1. Formulating the Research Problem	121
3.5.2. Conceptualising the Research Design	121
3.6. Research Design	122
3.6.1. Phases of Studies and Research Methods	123
Phase (1): Data Collection	123
Stage 1. Archives Data.....	123
Stage 2. Interview with Architect Experts	124
Stage 3. Image Sorting Survey.....	127
Phase (2): Data Analysis	132

Stage 1. Analysis of the Collected Architectural Precedents	132
Stage 2. Analysis of the Interviews.....	132
Stage 3. Analysis of the Image Sorting Survey	132
Phase (3): Grammar Construction	133
Phase (4): The Generation of 3D Prototypes of Building and Ground Architectural Precedents	133
Phase (5): Machine Learning Models to Cluster and Classify the Building and Ground Relationship.....	134
Phase (6): Developing a Computational Tool for Retrieving a Similar Precedent Building and Ground Relationship	137
Phase (7): System Usability Scale (SUS) of Using the Proposed Workflow of the Building and Ground Relationship	137
3.7. Chapter Summary	142
CHAPTER FOUR: ANALYSIS AND SYNTHESIS OF BUILDING AND GROUND RELATIONSHIP	144
4.1. Chapter Overview	145
Part (A) An Investigation of the Building and Ground Relationship	146
4.2. Interviews with Professional Architects.....	146
4.2.1. An Interview Guide with Architects to Uncover the Building and Ground Relationship	146
4.2.2. Analysis of Interview Responses.....	148
4.3. Architectural Precedents Collection and Visualisation	153
4.3.1. Statistical Analysis.....	153
4.4. Sorting Data Techniques; Image Sorting of Architectural Precedents.....	156
4.4.1. Main Building and Ground Relationship Image Sorting Survey Responses.....	156
4.4.1.1. Participant Analysis	157
4.4.1.2. Pre-Study Questions Analysis	158
4.4.1.3. Image Sorting Task Analysis	159
4.4.1.4. Post-Study Questions Analysis	161
4.4.2. The Building Meets the Ground Image Sorting Survey Responses	161
4.4.2.1. Participants Analysis.....	161
4.4.2.2. Pre-Study Questions Analysis.....	163
4.4.2.3. Image Sorting Task Analysis	164
4.4.2.4. Post-Study Questions Analysis	166

Part (B): Generative 3D Graph Topological Model of the Building and Ground Relationship	167
4.5. Extraction of Parametric Rules from Architectural Precedents	167
4.5.1. Sets of Parametric Rules	168
4.6. Generative 3D Topological Building and Ground Relationships	175
4.6.1. A Workflow for Generating Various 3D Parametric Models Using the Visual Programming Language and Environment "Grasshopper"	176
4.6.1.1. Implementation Strategy	176
4.6.1.2. Code Flowchart and the User Interface	177
4.6.1.3. The Required DGCNN Format	197
4.6.1.4. Results of the Generated 3D Topological Building and Ground Relationship Datasets	198
4.6.1.5. Errors in the Generated 3D Topological Building and Ground Relationship	204
4.6.1.6. Examples of the Generated 3D Topological Building and Ground Relationship (Flat Ground) (Figure 4.65 to Figure 4.68)	205
4.6.1.7. Examples of the Generated 3D Topological Building and Ground Relationship (Sloped Ground) (Figure 4.69 to Figure 4.72)	209
4.6.1.8. Examples of the Generated 3D Topological Building and Ground relationship (Level Ground) (Figure 4.73 to Figure 4.77)	213
4.7. Chapter Summary	218
CHAPTER FIVE	219
MACHINE LEARNING MODELS TO CLUSTER AND CLASSIFY BUILDING AND GROUND RELATIONSHIP	219
5.1. Chapter Overview	220
Part (A): Unsupervised Machine Learning to Cluster Architectural Precedents	221
5.2. Clustering the Relationship Between Buildings and the Ground Using Unsupervised Machine Learning Algorithms	221
5.2.1. Performance Evaluation	221
5.2.2. Data Pre-Processing	222
5.2.3. Experimental Results	223
5.2.3.1. All dataset Experimental Results	223
5.2.3.1.1. K-Means and K-Mode's Experiment Results	224
5.2.3.1.2. GMM Experiment Results	226
5.2.3.2. Residential Dataset Experimental Results	227
5.2.3.2.1. K-Means and K-Mode's Experiment Results	227

5.2.3.2.2. GMM Experiment Results	230
5.2.3.3. Public Dataset Experimental Results	231
5.2.3.3.1. K-Means and K-Mode's Experiment Results	231
5.2.3.3.2. GMM Experiment Results	233
Part (B): Graph Machine Learning 3D Model to Classifying the Building and Ground Relationship	235
5.3. Deep Graph Convolutional Neural Network	235
5.3.1. The Dataset Detail	236
5.3.2. Splitting the Dataset	236
5.3.3. Optimisation of Deep Graph Convolutional Neural Network (DGCNN)	236
5.3.3.1. Number of Neurons in the Convolutional Layer	237
5.3.3.1.1. Experiment 1	238
5.3.3.1.2. Experiment 2	238
5.3.3.1.3. Experiment 3	239
5.3.3.2. Number of Convolutional Layers	240
5.3.3.2.1. Experiment 4	241
5.3.3.2.2. Experiment 5	241
5.3.3.2.3. Experiment 6	242
5.3.3.2.4. Experiment 7	243
5.3.3.2.5. Experiment 8	244
5.3.3.2.6. Experiment 9	244
5.3.3.3. Number of Hidden Layers for Final Dense Layers	245
5.3.3.3.1. Experiment 10	245
5.3.3.3.2. Experiment 11	246
5.3.3.3.3. Experiment 12	247
5.3.3.4. Number of Epochs	248
5.3.3.4.1. Experiment 13	248
5.3.3.4.2. Experiment 14	249
5.3.3.4.3. Experiment 15	250
5.3.3.5. Learning Rate	251
5.3.3.5.1. Experiment 16	251
5.3.3.5.2. Experiment 17	252
5.3.3.5.3. Experiment 18	253

5.3.3.6. Batch Size.....	254
5.3.3.6.1. Experiment 19.....	254
5.3.3.6.2. Experiment 20.....	254
5.3.3.6.3. Experiment 21.....	255
5.3.3.6.4. Experiment 22.....	256
5.3.3.6.5. Experiment 23.....	257
5.3.4. Testing the Deep Graph Convolutional Neural Network (DGCNN) Architecture	257
5.3.5. Unbalanced Data (Under Sampling Approach).....	261
5.3.6. Prediction of New Building and Ground Relationship Scenarios.....	263
5.3.7. Applying the Different Deep Graph Neural Network (Deep Graph Library (DGL))	267
5.3.8. Unsupervised Graph-Level Representation Learning (UGLRL) Experimental Results	269
5.3.8.1. Date Conversion.....	270
5.3.8.2. Optimisation of the Unsupervised Graph-Level Representation Learning (UGLRL).....	271
5.3.8.2.1. Learning Rate.....	271
5.3.8.2.2. Number of Epochs.....	272
5.3.8.2.3. Batch Size.....	273
5.4. Chapter Summary.....	274
CHAPTER SIX: COMPUTATIONAL TOOL TO RETRIEVING SIMILAR BUILDING AND GROUND RELATIONSHIP PRECEDENTS (BGR TOOL).....	276
6.1. Chapter Overview.....	277
6.2. Develop Building and Ground Relationship (BGR) Tool.....	278
6.3. Usability Evaluation for the Developed Computational Tool: An Experimental Study	280
6.3.1. Criteria for the Evaluation Process.....	280
6.3.2. The Questionnaire Design.....	280
6.3.3. Choosing a Sample of Users.....	282
6.3.4. Solutions Produced by Participants.....	283
6.3.5. Results From the Usability Evaluation.....	293
6.4. Chapter Summary.....	301
CHAPTER SEVEN: RESEARCH DISCUSSION AND CONCLUSION.....	302
7.1. Introduction.....	303

7.2. Significance of the Findings and Research Contributions	304
7.2.1. A Collected Building and Ground Relationship Taxonomy	304
7.2.2. Clustering Building and Ground Relationship Using a Human Image Sorting Survey	305
7.2.3. The Use of Architectural Precedents in Architectural Design	306
7.2.4. The Process of Design Aided by Generative Design and Machine Learning.....	307
7.2.5. Unsupervised Machine Learning to Cluster Similar Architectural Styles Using Architectural Precedents	307
7.2.6. Generating 3D Graph Topological Model of Architectural Building and Ground Relationship	308
7.2.7. Graph Machine Learning Classification Using Architectural Building and Ground Relationship Precedents	310
7.2.8. Building and Ground Relationship Tool (BGR Tool)	312
7.3. Research Limitations	313
7.4. Recommendations for Future Work	314
REFERENCES.....	316
APPENDIX.....	335
Appendix: I. The Interview Guide with Architects	336
Appendix: II. The Interview Ethical Approval Forms	345
Appendix: III. Responses from the Interviews with Architects	350
Appendix: IV. Architectural Precedents Dataset.....	369
Appendix: V. Image Sorting Survey Questionnaire	460
Appendix: VI. Image Sorting Survey Ethical Approval Forms	472
Appendix: VII. Responses from the Participants Main Building and Ground Relationship Sorting Survey (One)	476
Appendix: VIII. Responses from the Participants Building Meet the Ground Image Sorting Survey (Two)	485
Appendix: IX. Screenshots for Components of the Computational Model for carrying out Generated Syntactical 3D Topological (BGR), using Rhino/Grasshopper	496
Appendix: X. Generated 3D Topological (BGR) Dataset.....	510
Appendix: XI. The K-Menes, K-Modes and GGM. Implementation with scikit-learn library	593
Appendix: XII. DGCNN implementation using PyTorch geometric	608
Appendix: XIII. System Usability Scale (SUS) Ethical Approval Forms	612

List of Figures

Figure 1.1: Timeline representing the development of physical building and ground designs	4
Figure 1.2: Structure of the thesis	13
Figure 1.3: Detailed Structure of the Thesis	14
Figure 2.1: Summary of the literature review plan	17
Figure 2.2: Modern pioneer architects' style of building and ground relationship	20
Figure 2.3: Two major Postmodernism approaches to the ground	22
Figure 2.4: Spidenethewood (2007) project by R&Sie(n)	24
Figure 2.5: Y House in the Catskills mountains by Steven Holl, 1999	25
Figure 2.6: Oblique function by Claude Parent and Paul Virilio	27
Figure 2.7: Rudolph Schindler embeds Harris House	28
Figure 2.8: Rudolph Schindler King Road House	28
Figure 2.9: Walker House	29
Figure 2.10: Wolfe House	29
Figure 2.11: Van Patten House	30
Figure 2.12: La Tourette, Le Corbusier	30
Figure 2.13: Casa Bernasconi, Luigi Snozzi 1989-90	31
Figure 2.14: Kiro-San observatory by Kengo Kuma	32
Figure 2.15: Forest Floor by Kengo Kuma	32
Figure 2.16: Soba restaurant by Kengo Kuma	33
Figure 2.17: Ockens House by Gleen Murcutt's	33
Figure 2.18: Topographie des Terrors by Zumthor	33
Figure 2.19: Farnsworth House by Mies van der Rohe	35
Figure 2.20: Resor House by Mies van der Rohe	35
Figure 2.21: Rudin House, Leymen by Herzog & de Meuron	36
Figure 2.22: Rodovre City Hall by Arne Jacobsen	37
Figure 2.23: The Line City Neom	37

Figure 2.24: A general form of building and ground relationship taxonomy.....	41
Figure 2.25: The process of Architectural design	43
Figure 2.26: A model of a design process based on Archer's work.....	44
Figure 2.27: Design as a scientific knowledge: the conjecture-analysis test model	46
Figure 2.28: The open form of the abductive model	48
Figure 2.29: Le Corbusier's Modulor	49
Figure 2.30: Buckminster Fueller Dymaxion House.....	49
Figure 2.31: Gunnison Homes	50
Figure 2.32: Plug-In City, Archigram's.	50
Figure 2.33: Habitat 67, Moshe Safdie	51
Figure 2.34: An example of the 'propagation-based system'	52
Figure 2.35: An example of how Grasshopper processes mathematical functions	54
Figure 2.36: Labelling a cube to prevent spatial ambiguity.....	55
Figure 2.37: Labelling a cube to prevent spatial ambiguity.....	56
Figure 2.38: A sample of the programming grammar	58
Figure 2.39: An example of a housing program with variable and fixed descriptions	59
Figure 2.40: A sample Values associated with housing programs	60
Figure 2.41: An example of the interface (MALAG) that translates user requirements into a design brief.....	61
Figure 2.42: The result of regular and non-regular Boolean operation with manifold input ...	64
Figure 2.43: The result of regular and non-regular Boolean operation with non-manifold input	64
Figure 2.44: Topologic Core Class Hierarchy	66
Figure 2.45: Eight key points of the Topologic application toolkit.....	67
Figure 2.46: Overview on the different graph models	70
Figure 2.47: Human learning vs. Machine learning.....	72
Figure 2.48: ML families. An ML approach is characterized by a square box in the first column; an algorithm example in the second column; and an example of an application which uses the approach in the third column.....	73

Figure 2.49: The centroid clustering algorithm processes	75
Figure 2.50: An example of ANN structure.....	78
Figure 2.51: An example of CNNs structure	78
Figure 2.52: An example of RNN structure.....	79
Figure 2.53: An examples of GANs structure	79
Figure 2.54: The general structure of DGCNN.....	80
Figure 2.55: Left; 2D convolutional, right; graph convolutional.....	82
Figure 2.56: Example of embedding a graph into 2D space with different granularities	86
Figure 2.57: Unsupervised graph-level representation learning model	87
Figure 2.58: The structure of DGCNN.....	88
Figure 2.59: Literature review topics range from broad to specific related work.	103
Figure 3.1: Quantitative research methods.....	111
Figure 3.2: Qualitative research methods.....	113
Figure 3.3: Experimental research methods	117
Figure 3.4: Main building and ground relationships	129
Figure 3.5: Building Meet the Ground.....	129
Figure 3.6: An example of the workshop environment.....	130
Figure 3.7: DGCNN model is structured by author after	136
Figure 3.8: unsupervised graph-level representation learning (UGLRL)	136
Figure 3.9: BGR tool three three main steps	137
Figure 3.10: Grade rankings of SUS scores	139
Figure 3.11: “A Comparison of Questionnaires for Assessing Website Usability”	139
Figure 3.12: An example of SUS questionnaire	140
Figure 3.13: An example of SUS calculating the score	141
Figure 3.14: Research Design Workflow.....	143
Figure 4.1: STC Campus (designed by the interviewee)	149
Figure 4.2: Twelve dwellings designed by bRijUNi architects	149
Figure 4.3: Obama's Public Library (designed by the interviewee).....	150

Figure 4.4: An example of the architectural precedents that collected in MS Access.....	153
Figure 4.5: Period of collected architectural precedents	154
Figure 4.6: Type of collected architectural precedents.....	154
Figure 4.7: Status of collected architectural precedents	154
Figure 4.8: Location of collected architectural precedents.....	155
Figure 4.9: Distribution of collected architectural precedents	155
Figure 4.10: Repetition of collected architectural precedents.....	156
Figure 4.11: The completion, time taken and location of the participants on main building and ground relationship image sorting survey.....	156
Figure 4.12: Number of participants that completed or abandoned the main building and ground relationship image sorting survey.....	157
Figure 4.13: Participants' careers who responded to the main survey on building and ground relationships	157
Figure 4.14: The worldwide distribution of the participants on the main building and ground relationship image sorting survey	157
Figure 4.15: Number of responses received from different countries to the main building and ground relationship image sorting survey.....	158
Figure 4.16: The time of the responses received to the main building and ground relationship image sorting survey	158
Figure 4.17: The agreements between the participants for all images	159
Figure 4.18: The number of images that match the expert clustering answer.....	159
Figure 4.19: A total of 1255 images sorted, 894 images were grouped in same cluster, however, 361 images were ground with different classes.....	160
Figure 4.20: Score of the participants or the main building and ground relationship image sorting survey	161
Figure 4.21: The completed number, time taken, and the location of the building meets the ground image sorting survey participants.....	161
Figure 4.22: Number of participants completed the building meets the ground image sorting survey participants	162
Figure 4.23: Participants' careers who responded to the building meets the ground image sorting survey participants	162

Figure 4.24: The worldwide distribution of the participants received from "the building meets the ground" image sorting survey	162
Figure 4.25: Number of responses received from different countries to "the building meets the ground" image sorting survey	163
Figure 4.26: The time of the responses received to "the building meets the ground" image sorting survey	163
Figure 4.27: The agreements between the participants for all images	164
Figure 4.28: The number of images that match the expert clustering answer	165
Figure 4.29: A total of 1050 images sorted, 485 images were grouped in same cluster, however, 565 images were ground with different classes.....	165
Figure 4.30: Score of the participants of the building meets the ground image sorting survey	167
Figure 4.31: Used building and ground relationship taxonomy to extract the rules	167
Figure 4.32: Ground (G) design parameter rules	168
Figure 4.33: Parametric rules for the configuration of Flat Ground (FG).....	169
Figure 4.34: Parametric rules for the configuration of Sloped Ground (FG).....	169
Figure 4.35: Parametric rules for the configuration of Level Ground (LG).....	170
Figure 4.36: Parametric rules for the configuration of the building (B).....	171
Figure 4.37: Parametric rules for the configuration of columns (CL) (Plan).....	173
Figure 4.38: Parametric rules for the configuration of Columns (CL) (Elevation)	173
Figure 4.39: Parametric rules for the configuration of the Core (Co) (Plan).....	174
Figure 4.40: Parametric rules for the configuration of the Core (Co) (Elevation).....	174
Figure 4.41: Parametric rules for the configuration of Plinth (P).....	175
Figure 4.42: Left: an example CellComplex. Cell A and Cell B are said to be adjacent because they share Face. Figure 4.42 Right: an example dual graph of the CellComplex. Each Cell is represented by a Vertex and the Vertices of adjacent Cells are connected by an Edge	177
Figure 4.43: Script for generating the allowable built-up area for the building	179
Figure 4.44: Script for generating the Flat ground (FG)	180
Figure 4.45: Script for generating the sloped ground (SG).....	180
Figure 4.46: Script for generating the level ground (LG).....	181
Figure 4.47: Script for generating plinth (P)	182

Figure 4.48: Script for generating Columns (CL).....	184
Figure 4.49: Script for generating vertical circulation “Core” (VC)	185
Figure 4.50: Script for generating Building (B)	186
Figure 4.51: Create slicing curves for building geometries	187
Figure 4.52: Create slicing curves for ground and columns geometries	187
Figure 4.53: Create slicing curves for plinth geometries.....	188
Figure 4.54: An example of converting Geometry to Topology	189
Figure 4.55: Setting the dictionary script	190
Figure 4.56: Script for creating Topological Graph.....	191
Figure 4.57: Script for creating Stream Filter	192
Figure 4.58: Script for creating the python loop	192
Figure 4.59: Script for creating the Colibri Iterator and save the produced views	193
Figure 4.60: Grasshopper definition of generating 3D parametric models and their associated topological dual graph.....	196
Figure 4.61: The general data set format required for DGCNN	197
Figure 4.62: Examples of building and ground iteration on flat ground	199
Figure 4.63: Examples of building and ground iteration on sloped ground.....	201
Figure 4.64: Examples of building and ground iteration on Level ground	203
Figure 4.65: Sample of automatically generated (Separation on flat ground).....	205
Figure 4.66: Sample of automatically generated (Separation with plinth on flat ground) ...	206
Figure 4.67: Sample of automatically generated (Adherence and Adherence with plinth on flat ground)	207
Figure 4.68: Sample of automatically generated (Interlock on flat ground).....	208
Figure 4.69: Sample of automatically generated (Separation with plinth on sloped ground)	209
Figure 4.70: Sample of automatically generated (Separation on sloped ground)	210
Figure 4.71: Sample of automatically generated (Adherence on sloped ground)	211
Figure 4.72: Sample of automatically generated (Adherence with plinth on sloped ground)	212

Figure 4.73: Sample of automatically generated (Separation on Level ground).....	213
Figure 4.74: Sample of automatically generated (Separation with plinth on Level ground)	214
Figure 4.75: Sample of automatically generated (Adherence on Level ground).....	215
Figure 4.76: Sample of automatically generated (Adherence with plinth on Level ground)	216
Figure 4.77: Sample of automatically generated (Interlock on Level ground).....	217
Figure 5.1: Transferring normal numerical data to one-hot encoding.....	223
Figure 5.2: Silhouette score Elbow for K-means clustering (left) and K-modes clustering (right)	224
Figure 5.3: t-SNE embedding of the K-means clusters (left) and K-modes clusters (right)...	225
Figure 5.4: Examples of clusters of architects' styles in four groups of building and ground relationships	225
Figure 5.5: Silhouette Score Elbow for GMM clustering (Left), t-SNE embedding of GMM clusters (Right).....	227
Figure 5.6: Silhouette Score Elbow for K-Means clustering (Left) and K-Mode's clustering (Right)	228
Figure 5.7: t-SNE embedding of the K-means clusters (left) and K-modes clusters (right)...	228
Figure 5.8: Examples of clusters architects' styles in different five groups of building and ground relationship for residential houses	229
Figure 5.9: Silhouette Score Elbow for GMM clustering (Left), t-SNE embedding of GMM clusters (Right).....	230
Figure 5.10: Silhouette score Elbow for K-Means Clustering (Left) and K-Modes Clustering (Right)	231
Figure 5.11: t-SNE embedding of the K-Means clusters (Left) and K-Modes clusters (Right)	232
Figure 5.12: Examples of clusters architects' styles in different four groups of building and ground relationship for public dataset.....	232
Figure 5.13: Silhouette Score Elbow for GMM clustering (Left), t-SNE embedding of GMM clusters (Right).....	233
Figure 5.14: : The general structure of DGCNN.....	235
Figure 5.15: The dataset split into training, validation, and testing sets	236
Figure 5.16: Experiment 1 average accuracy (left), average loss (right)	238
Figure 5.17: Experiment 2 average accuracy (left), average loss (right)	239

Figure 5.18: Experiment 3 average accuracy (left), average loss (right)	240
Figure 5.19: Experiment 4 average accuracy (left), average loss (right)	241
Figure 5.20: Experiment 5 average accuracy (left), average loss (right)	242
Figure 5.21: Experiment 6 average accuracy (left), average loss (right)	243
Figure 5.22: Experiment 7 average accuracy (left), average loss (right)	243
Figure 5.23: Experiment 8 average accuracy (left), average loss (right)	244
Figure 5.24: Experiment 9 average accuracy (left), average loss (right)	245
Figure 5.25: Experiment 10 average accuracy (left), average loss (right)	246
Figure 5.26: Experiment 11 average accuracy (left), average loss (right)	247
Figure 5.27: Experiment 12 average accuracy (left), average loss (right)	247
Figure 5.28: Experiment 13 average accuracy (left), average loss (right)	249
Figure 5.29: Experiment 14 average accuracy (left), average loss (right)	250
Figure 5.30: Experiment 15 average accuracy (left), average loss (right)	251
Figure 5.31: Experiment 16 average accuracy (left), average loss (right)	252
Figure 5.32: Experiment 17 average accuracy (left), average loss (right)	253
Figure 5.33: Experiment 18 average accuracy (left), average loss (right)	253
Figure 5.34: Experiment 20 average accuracy (left), average loss (right)	255
Figure 5.35: Experiment 21 average accuracy (left), average loss (right)	256
Figure 5.36: Experiment 22 average accuracy (left), average loss (right)	256
Figure 5.37: Experiment 23 average accuracy (left), average loss (right)	257
Figure 5.38: Test of the saved model using unseen data, average accuracy (left), average loss (right)	258
Figure 5.39: Experiment of under-sampling approach average accuracy (left), average loss (right)	262
Figure 5.40: Experiment of under-sampling 2 approach average accuracy (left), average loss (right)	262
Figure 5.41: Grasshopper definition to create new building and ground scenarios	264
Figure 5.42: Scenario 1 (left), Scenario 2 (right)	265
Figure 5.43: Scenario 3 (left), Scenario 4 (right)	266

Figure 5.44: Scenario 5 (left), Scenario 6 (right).....	266
Figure 5.45: Scenario 7 (left), Scenario 8 (right).....	266
Figure 5.46: Scenario 9 (left), Scenario 10 (right).....	267
Figure 5.47: Scenario 11 (left), Scenario 12 (right).....	267
Figure 5.48: DGL performance plots, average accuracy, and average loss.....	268
Figure 5.49: The DGL Workflow in Blender (Training the DGL).....	268
Figure 5.50: The DGL Workflow in Blender (Prediction using the saved DGL).....	269
Figure 5.51: Graph 1 from data. Visualised with matplotlib. The table shows how an adjacency matrix, node labels and graph indicators work within the text files.....	269
Figure 5.52: First 25 graphs of the data were created and visualized using network X and matplotlib.	270
Figure 5.53: t-SNE plot for, 1e-5(top-left),1e-4(top-right),1e-3(below-left) and 1e-2(below-right)	272
Figure 5.54: t-SNE plot for 10 epochs (left) and 50 epochs (right).....	273
Figure 5.55: t-SNE plot for 64 batch sizes (left) and 128 batch sizes (right)	273
Figure 6.1: The Workflow of the BGR Tool.....	278
Figure 6.2: Detailed Workflow of the created BGR tool.....	279
Figure 6.3: Amount of time for completing the design using BGR tool	285
Figure 6.4: Number of questions from participants regarding commands and design processes	285
Figure 6.5: Number of errors faced the users during implementation process.....	286
Figure 6.6: An example of the initial interface provided to participants	286
Figure 6.7: Solution produced by participant 1.....	287
Figure 6.8: Solution produced by participant 2.....	287
Figure 6.9: Solution produced by participant 3.....	288
Figure 6.10: Solution produced by participant 4.....	288
Figure 6.11: Solution produced by participant 5.....	289
Figure 6.12: Solution produced by participant 6.....	289
Figure 6.13: Solution produced by participant 7.....	290

Figure 6.14: Solution produced by participant 8.....	290
Figure 6.15: Solutions produced by participant 9	291
Figure 6.16: Solution produced by participant 10.....	291
Figure 6.17: Solution produced by participant 11.....	292
Figure 6.18: Solutions produced by participant 12	292
Figure 6.19: The system usability score of BGR tool	293
Figure 6.20: Results of participants' familiarity with the used tools.....	294
Figure 6.21: Results of the usability of the generative building and ground workflow	297
Figure 6.22: Results of the usability for the Deep Graph Neural Network system	298
Figure 6.23: Results of the whole BGR tool system's usability.....	299

List of Tables

Table 2.1: A review of studies concerning the relationship between the building and the ground	90
Table 2.2: A review of studies of using machine learning approaches to cluster similar architectural style precedents.....	93
Table 2.3: A review of studies' classification of architectural works using graph topological machine learning in architecture design	95
Table 3.1: Four common types of research methodologies.....	111
Table 3.2: Differences between the structured interview and qualitative interview	115
Table 3.3: Qualitative, quantitative, and mixed-method approaches	119
Table 3.4: Phases of studies and Research Methods	123
Table 3.5: Research objective and research methods.....	142
Table 4.1: The interview guide with architects	146
Table 4.2: Number of participants answering pre-study questions	158
Table 4.3: A confusion matrix for all the main building and ground relationship image sorting surveys.....	160
Table 4.4: Number of participants answering pre-study questions.....	164
Table 4.5: A confusion matrix to all building meets the ground image sorting survey responses	166
Table 4.6: Sets of parametric rules that define the language of the building and ground relationship.....	168
Table 4.7: The three primary steps of the generation process	178
Table 4.8: Generating allowable built-up area objects parameters.....	179
Table 4.9: Generating ground objects parameters	180
Table 4.10: Generating plinth objects parameters	181
Table 4.11: Generating columns objects parameters	182
Table 4.12: Generating vertical circulation "Core" objects parameters	184
Table 4.13: Generating Building objects parameters.....	185
Table 4.14: Flat ground iterations	198
Table 4.15: Sloped ground iterations	200
Table 4.16: Level ground iterations.....	202
Table 4.17: Errors in labelling the vertices of the dual graph	204
Table 5.1: Results of different machine learning algorithms (K-Means, K-Modes and GMM) with different K numbers	227

Table 5.2: Residential dataset experimental results of different machine learning algorithms (K-Means, K-Modes and GMM) with different numbers of K.....	231
Table 5.3: Residential dataset experimental results of different machine learning algorithms (K-Means, K-Modes and GMM) with different numbers of K.....	234
Table 5.4: The hyperparameters used to tune the best model	237
Table 5.5: Tuning number of neural in the convolutional layer.....	237
Table 5.6: Tuning the number of convolutional layers.....	240
Table 5.7: Tuning the number of hidden neurons for final dense layers.....	245
Table 5.8: Tuning the number of epochs.....	248
Table 5.9: Tuning the learning rate	251
Table 5.10: Tuning the batch size	254
Table 5.11: Ten examples of unseen datasets	260
Table 5.12: A confusion matrix of 640 unseen datasets	260
Table 5.13: The original dataset used in optimising the DGCNN	261
Table 5.14: New balanced dataset used to demonstrate the unbalanced data effect.....	261
Table 5.15: Twelve examples of new scenarios	263
Table 5.16: Accuracy results using various learning rates.....	271
Table 5.17: Accuracy results using various numbers of epochs.....	272
Table 5.18: Accuracy results using various batch sizes	273
Table 5.19: Best K-means experiments for the different dataset	274
Table 6.1: Sample of users who participated in the experimental study.....	283
Table 6.2: All the Solutions produced by participants.....	284

CHAPTER ONE

INTRODUCTION

Chapter 1: Introduction

1.1. Chapter Overview

This chapter of the thesis introduces and emphasises the need for the study. After articulating the research problem, the study's aim and objectives are identified. Given its originality and potential contributions, the significance of this research is rationally argued. The final section of this chapter describes the methodological design that has been adopted to implement this method.

1.2. Research Motivation

The ground is an integral aspect of a building, and the construction of an object creates a relationship between the two elements (Manferdini 2016). It might be against the context, or it might accept the existence of local conditions, but the building and ground question remains unavoidable. It has become evident that the fundamental "shelter" crafted into the earth's crust has evolved into a highly sophisticated building envelope that not only separates and protects us from the elements, but also allows its inhabitants to interact with and enjoy its surroundings. Carefully considering the relationship between the building and the ground can create synergies between the building and its context to enable such interaction and enjoyment. Enhancing the integration between the building and the ground will connect the architecture with the landscape and merge the building with the ground, which will reconfigure architecture's position within nature.

This study seeks to reveal these building and ground relationships and introduce them to the architect in the early design stages before other architecture, engineering and construction systems are incorporated into the design. Postponing the consideration of the ground and building relationship will negatively impact other architectural systems. For example, the topography and soil makeup of a site can significantly affect several other aspects of the design such as the building's orientation, its access, and the choice and design of its foundational structural system among others. A poorly considered building/ground relationship may result in a building that does not take advantage of what the site offers. Postponing the examination of the building/ground relationship can also be costly and time-consuming as several design decisions and material choices may need to be revised.

Obtaining an understanding of the approaches, styles, and similarities between building and ground relationships begins with clustering and classification. Yet, few studies have examined the clustering and classification of architectural forms and their relationship to the ground

Chapter 1: Introduction

(Berlanda 2014; Porter 2018). Additionally, no dataset of architectural precedents exists that documents such relationships. Thus, a motivation for this dissertation is to provide a well-structured dataset that will assist the architect and designer when referring to a similar building and ground relationship.

1.3. Scope and Focus

This study focused on the formal aspects of the relationship between the building and the ground. It should be noted, however, that the building's relationship to its context also encompasses several other aspects. For example, this framework can be extended to address issues such as thermal factors, access control, health and safety, relation to the city, impact on adjacent buildings and neighbourhoods, pedestrian flows, and the identity of the building. Thus, the contribution of this study is not only in analysing specific formal aspects but also in developing a general workflow/framework applicable to studying other aspects. This goal can be achieved by passing different information through the graph and its nodes, potentially including different datasets, such as the aforementioned aspects.

1.4. The Background and Nature of the Research Problem

1.4.1. Building and Ground Relationship

Historically, the building and ground have long undergone deliberation in the architecture field. Vitruvius stated that “a very healthy site” is the first principle of founding a city location. The Roman military engineer explained the healthy site as being “high, neither misty nor frosty, and in a climate neither hot nor cold, but temperate” (Vitruvius 1916, p. 17). In the Middle Ages, the ground was central to the design and construction with a religious character. The master masons' architect would etch the plan into the earth and use projection systems to construct the building from the ground up (Frankl 1945). This engagement remains grounded even with the revolution of technological advancement. Semper described in “The Four Elements of Architecture” that the mound represents one of the architectural elements that should engage with the building and the surrounding context (Semper et al. 1989). Modern architects, such as Ludwig Mies van der Rohe and Le Corbusier, design projects that float above the earth, while others construct an utterly new ground on the existing ground. Richard Neutra and Frank Lloyd Wright sought to bridge the gap between architecture and the surrounding natural environment with a more significant effort than Le Corbusier and Ludwig Mies van der Rohe (Porter 2015). Recently, however, technological, philosophical, and geopolitical changes have improved the notion of connections with the ground. Contemporary

Chapter 1: Introduction

architects use a similar approach to the ground but at the same time more complex and conformist to the ground. Some have adopted the idea of ignoring the ground using autonomous objects, and others have tried to employ the case of the division between landscape and building with field conditions, building and landscape urbanism (Porter 2017). Despite these approaches and movements, this study will focus on the last century of this movement as the scope of work (Figure 1.1). This study focuses on the last century because technological advances, such as computer aided design (CAD) systems, computational tools, and software, have increasingly been used during this period. This has influenced the architecture and its impact on the ground in a more sophisticated and ambitious manner. Therefore, the study is divided into three periods: Modernism, Postmodernism and Contemporary.

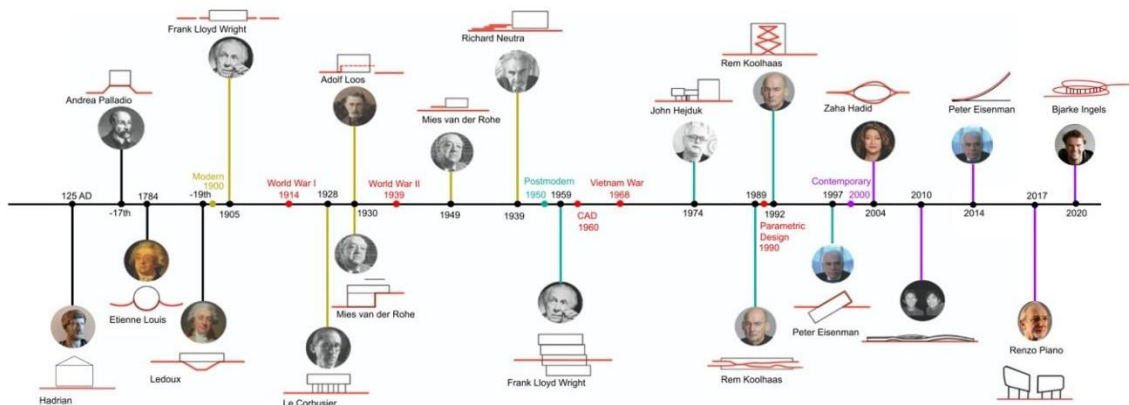

Figure 1.1: Timeline representing the development of physical building and ground designs (by author)

1.4.2. Building and Ground Relationship Aided by Computational Tools

Architectural and urban morphological evidence indicates that quantitative research techniques, aided by computational tools, help achieve a more efficient design process (Gil et al. 2012). Although the effect of such an approach in established architectural undertakings remains limited, studies suggest that employing ML technologies can raise awareness of architectural forms and refine their recognition and classification (Shalunts, Gayane, Yll Haxhimusa 2011; Chen et al. 2015a; Lee and Lee 2016a; Ferrando et al. 2019). However, several challenges still limit the adaptation of these technologies. Firstly, supervised machine learning requires a significant amount of labelled data to aid the learning process; this labelling must occur manually (Sun et al. 2020). Secondly, most machine learning processes depend on 2D pixel-based image recognition (Shalunts, Gayane, Yll Haxhimusa 2011; Shalunts et al. 2012; Yoshimura et al. 2019). While this approach may seem compatible with the representation of the available data, mainly plans and drawings, it leads to major limitations.

Chapter 1: Introduction

The building and ground relationship is 3D, topologically connected, and complex. However, most machine learning systems cannot infer 3D and semantic information directly from images. The data simply represents a vector of mostly low-resolution RGB values to an ML algorithm. If the data is 3D in nature and semantically rich, that information must be stripped away, and the data converted into images for an ML algorithm to operate appropriately. The shortage of distributable 3D sets of data can cause issues because any available sets have varied formats, appropriateness, usability, and licence agreements (Gröger and Plümer 2012).

Even if 3D data sets become available, a challenge remains in recognising and classifying them. Some researchers have focused on 3D models' capacity to recognise features, the process of which involves capturing numerous two-dimensional depictions of the models before aligning them with an image-based query (Sarkar et al. 2017; Kasaei 2019). However, such an approach fails to capture the 3D topology embedded in the data. A slightly more sophisticated approach involves extracting features from a 3D model and encoding them as a vector for use as input into a neural network (Qin et al. 2014). This approach extracts only a portion of the data and must transform it into a standard input vector. It also ignores the topological information that can indicate the type of object.

A promising approach involves using machine learning on graphs (Vishwanathan et al. 2010; Kriege and Mutzel 2012; Orsini et al. 2015). Some approaches encounter limitations in that they decompose the graphs into small substructures, such as walks or paths, and derive the similarity between graphs based on a summation of attributes. Some graph-based ML systems such as the Deep Graph Convolutional Neural Network (DGCNN) and the Unsupervised Graph-level Representation Learning Networks (UGLRL), and Deep Graph Library (DGL) bypass such constraints by offering a machine learning model that categorises graph-based information. These networks prove beneficial because they accept graphs without changing the data into vectors. Using these machine learning methods offers the following benefits: 1) grouping architectural precedents building and ground relationship approaches into similar classes, the architectural precedent resource can be made more readily available; 2) classifying 3D conceptual models based on their topological graphs rather than on their 2D representation.

1.5. The Significance and Contributions of the Study

To enable architects to make informed design decisions, regarding the building and ground relationship, digital aids must help them first identify building and ground relationship in the early design stages. Manually performing this task can be costly, time-consuming, and prone to errors. In the age of AI, and especially Graph machine learning (GML), designers can predict

Chapter 1: Introduction

the relationship of buildings and the ground during the design process because of automatic classification. This framework has the potential to introduce into the design process similar precedents such that the designer can quickly estimate the consequences of their design decisions. However, to date, AI techniques have focused on the use of 2D visual representations of building features to classify buildings. Making use of only pixel information reduces the ability of the system to use 3D information. However, encoding a full 3D model is challenging and too time consuming for ML. Therefore, because of topological graphs, building representations are no longer constrained by the limitations of 2D pixels and do not necessitate the complexity of encoding a full 3D model. Thus, the challenge shifts to having the ability to derive topological graphs from a conceptual model. This study presents to the practitioner the importance of taking into consideration the building's ground at the earliest possible design stages before the complexity and rigidity of a fully developed building information model (BIM) take hold.

Considering that AI and ML both play a crucial role in science and architecture; the findings of this research will contribute to architects' practice and education. Several architects have been interviewed and have argued that more effective work is needed to explore the relationship between the building and the ground. Therefore, an architect that applies the recommended approach derived from the results of this research can retrieve the database and improve its design by studying similar precedents.

Due to this research, the BGR tool has been developed, which represents one of the significant contributions in this dissertation. Using the BGR tool begins with creating the building ground relationship object. The architects will develop a 3D design with simple geometry and then convert it into its dual 3D topological graph. The user then implements the saved DGCNN machine learning model to predict the 3D graph of the conceptual design. Afterwards, the user retrieves similar architectural precedents for the new design. In the early stages of the design process, this BGR tool process will enable the student and architect to develop a knowledge system of how the building can meet the ground. Furthermore, saving and quantifying this process can measure the efficiency and value of the BGR tool developed in this study in Chapter 6.

This research will contribute to the body of architectural research knowledge through the following:

1. Helping architects review precedents during the design process and helping them study and gain from previous practical experience. "It is an assessment of knowledge gained by others rather than research in the strict definition of the term" (Joroff et al. 1983, p. 21).

Chapter 1: Introduction

2. Producing a database catalogue of how a building meets the ground during the contemporary, postmodern, and modern periods.
3. Applying a 3D graph machine learning classification approach rather than a 2D image.
4. Evaluating the machine learning models and locating the strongest algorithm that works with this database.

1.6. Research Aim, Questions and Objectives

The literature review extensively discusses the building and the ground. However, no precedent data set focuses on architecture design building and ground relationships employable as a guide. This approach requires implementing a computational workflow to help the architects gain a clear understanding of the building and ground taxonomy and generate a guideline for a first-stage design process through classifying building and ground relationships. Therefore, a hypothetical machine learning algorithm model aided with computational tools using 3D graph theory represents the most robust method to help establish this computational workflow.

This dissertation aims to design a proof-of-concept workflow that leverages topological graph machine learning models to classify building and ground relationships. Students and practitioners can then use this workflow (which we entitle Tool) to retrieve architectural precedents for educational purposes.

To accomplish this aim, the research explores the following **key questions**:

1. What are current formal building and ground relationships?
2. How could we measure and code the formal relationship between the building and the ground into 3D topological parameters?
3. How could machine learning models be developed that classify and cluster the building and ground relationship?
4. How could this machine learning model help architects?

This research achieves the following four **research objectives**:

Objective 1: Investigation of building and ground shaping:

1. Investigate building and ground case studies to explore how the relationship with the ground is prefigured by reading the theoretical text of each architect's position on their work.
2. Sort hundreds of case studies into a computational database.
3. Identify the existing building and ground relationship taxonomy.

Chapter 1: Introduction

Objective 2: Computational methods to prototype and generate a 3D parametric model:

1. Extract parametric rules from architectural precedents.
2. Create prototype building and ground relationship rules using shape grammars.
3. Utilise the Grasshopper plug-in software to create building and ground prototypical design patterns.
4. Generate a large synthetic data set of 3D topological architectural building and ground relationships.
5. Label and convert the data set into semantically rich topological graphs using graph theory.

Objective 3: Machine learning model as a tool for classifying and clustering:

1. Enables unsupervised machine learning computer systems to cluster and identify unusual patterns or emergent architectural trends. Clustering techniques are an essential tool in this process for organising large data sets.
2. Enables supervised machine learning to classify the 3D prototype architectural precedents models based on a 3D topological graph rather than 2D images.
3. Enables an unsupervised graph representation learning machine learning model to cluster the building and ground relationship.

Objective 4: Create a building and ground relationship tool (BGR tool)

1. Develop a computational tool for retrieving a similar precedent building and ground relationship.
2. Test the usability of the proposed workflow of the BGR tool.

1.7. Research Design and Methodology

The development of a computational machine learning model for clustering and classifying the building and ground relationship requires an intelligent and sensitive research approach. To achieve these goals, a triangulation of two methods employs. First is **Qualitative**, which includes interviews with architects. Second is **Quantitative**, which includes archives of precedents' image data. An image sorting survey is distributed to architects and computational design approaches.

a. Qualitative approach

The qualitative approach started with Interviews. The interview process provides insight and detailed explanations for the phenomenon under investigation (Suter 2014). This technique seeks to explore the architectural design for building and ground relationships and validate

Chapter 1: Introduction

the building and ground relationship taxonomy. Finally, it obtains an expert perspective on how it remains essential to classify and cluster building and ground relationships.

b. Quantitative approach

The quantitative approach started with collect and archive architectural precedent Images. A random sample of significant architectural precedents images was recruited from a period spanning the 19th century to the present day.

Since the precedent study was collected and archived in the previous stage, an image sorting survey clusters the building and ground relationship into a group. This approach helps determine how the participants think or feel about the sorted topic.

Then a computational design approach used to create a database and methods for designers to make better decisions during the early design stage by considering the ground. The information gained from the analytical process and responses collected from interviews and the image sorting survey establish a database that identifies design elements (vocabularies) and spatial relationships between these features according to predefined criteria (building and ground taxonomy). Shape grammars, established by Stiny and Gips (1972), is adopted as a rule-based system for generating layouts. Using these created rules as a computational design workflow enhances the representation of 3D topological models and embeds semantic information (Digital Prototyping Design Patterns). Finally, a generative computational approach automatically creates a large synthetical data set of the building and ground relationship.

After generating a large synthetical data set of the building and ground relationship, ML models used to cluster and classify the building and ground data set into different classes to group similar building and ground approaches. This includes two different models:

- a. Unsupervised Machine Learning Model: The clustering algorithm model will be used to cluster and analyse the database into a group of similar building and ground relationships.
- b. Supervised Machine Learning Model: The graph classification machine learning model aims to identify the category/class under which new data will fall.

Accordingly, the research is outlined in five phases.

Phase(1) Data collection. This phase includes:

- a) Collecting 500 significant architectural precedents over three major architectural periods: contemporary, postmodern, and modern.

Chapter 1: Introduction

- b) Archiving the case studies in the database programme (Microsoft Access Database Software).
- c) Conducting an image storing survey to sort the building and ground relationship into similar groups.
- d) Conducting interviews with architects.
- e) Reviewing the computational models that could analyse the data.
- f) Evaluating the ability and quality of the computational models used in the analysis phase.

Phase(2) Data analysis. This phase includes:

- a) Developing a scheme of analysis for addressing the different qualities of the selected data.
- b) Encoding and analysing the results of the image sorting survey of the building and ground relationship.
- c) Measuring the error or non-similarity of the image sorting survey.
- d) Encoding and analysing responses from interviews.
- e) Translating the relationship between the building and the ground into specific parameters.

Phase(3) The development of computational design tools. This phase includes:

- a) Translation of the constructed shape grammars that derives from prototypical design patterns via architectural precedents into an interactive computational design tool, using Rhino/Grasshopper software.
- b) Generating a large synthetical data set of the 3D topological architectural building and ground relationship.
- c) Offering architects, a rule of translating their conceptual design models into a semantically rich topological dual graph that could classify their conceptual design in relation to the way the building meets the ground.

Phase(4) Machine learning models (unsupervised clustering algorithm and supervised graph classification). This phase includes:

- a) Developing unsupervised machine learning models to cluster aspects of an architect's building design style with respect to how the buildings in question relate to the ground.
- b) Examining the most well-known unsupervised learning algorithm clustering techniques.

Chapter 1: Introduction

- c) Enabling machine learning to classify 3D abstract models of the building and ground relationship architectural precedents based on a topological graph rather than 2D images.
- d) Training the graph convolutional deep neural networks DGCNN using the 3D building and ground relationship graph kernel database.

Phase(5) The generation of new solutions, validation of results and usability evaluation for the model. This phase includes:

- a) Training the machine learning models using the experimental study and generating and evaluating new solutions.
- b) Retrieve similar architectural precedents of building and ground relationships in order to educate the users (architects) on different methods of building and establishing ground relationships.

1.8. Research Structure and Key Outcomes

The structure of this thesis comprises seven chapters, including this introductory chapter (Figure 1.2 and 1.3).

Chapter Two: Literature review, include two parts. Part (A) starts with the theoretical background of the research and looks at the concept of building and ground relationship approaches during the 19th and 20th centuries. This part also discusses in detail the Toma Berlanda lexicon of how buildings touch the ground. The conclusion from this part summarises the problems and potential outcomes of different building and ground relationship approaches. Moreover, this part will provide a building and ground relationship taxonomy. Part (B) of this chapter reviews the design processes. Moreover, the chapter presents an overview of the computational design process and the different potentials and limitations of analytical and generative systems that could help achieve the goal of the study. Moreover, this part will focus on reviewing machine learning models and their application in the early stage of the architectural design process. The conclusion from this part summarises the problems and potential outcomes of machine learning models, research gaps and related studies of clustering and classifying machine learning models.

Chapter Three: Research design and Methodologies, this chapter presents an overview of the theoretical paradigms and approaches used in this research. It also describes the phases, methods and techniques that answer the research questions.

Chapter Four: Analysis and synthesis of the building and ground relationship, this chapter includes two parts. Part (A) presents data collected from different resources: interviews,

Chapter 1: Introduction

image archiving and the image sorting survey. Moreover, it presents an analysis of the collected data to be used for extracting a physical building and ground relationship. Part (B) presents the rules that were created to generate a large synthetic data set of architectural building and ground precedents. Moreover, it shows the workflow of utilising computational software and libraries, such as Python, Grasshopper and Topologic, to generate, label and convert the data set into semantically rich topological graphs. The result is a large 3D data set ready for use in different graph machine learning models.

Chapter Five: Machine learning models to cluster and classify the building and ground relationship, includes two parts. Part (A) examines different unsupervised machine learning models such as K-Means, K-Modes and Gaussian Mixture Models (GMM). This ML model investigates the cluster aspects of an architect's building design style with respect to how the building in question relates to the ground. This results in a comparison of three unsupervised clustered ML models. Part (B) examines an end-to-end deep graph convolutional neural network (DGCNN) to classify 3D graph topological models. This results in an ML (DGCNN) model that can predict a class of any new building and ground relationship architectural precedents. Moreover, it examines Unsupervised Graph-Level Representation Learning (UGLRL) for graph clustering. This results in an ML model that can map a graph into a fixed-length vector or matrix that captures a key feature while reducing the dimension in a generalised way.

Chapter Six: Computational tool to retrieving similar building and ground relationship precedents (BGR Tool), This chapter presents the general Interface of computational design tools for the building and ground relationship. Moreover, it examines the pre-trained machine learning models to predict new building and ground classes. This results in an overview of how the architect/practises could use the workflow of the computational design tools. Finally, this chapter used the system usability scale (SUS) to evaluate the BGR tool.

Chapter Seven: Research discussion and conclusion, present an overview of the findings, research conclusions, practical applications, and future research recommendations. Moreover, the challenges and research limitations will undergo discussed in this chapter.

Appendices: These provide detailed drawings, architectural presidents images and research ethical approval.

Chapter 1: Introduction

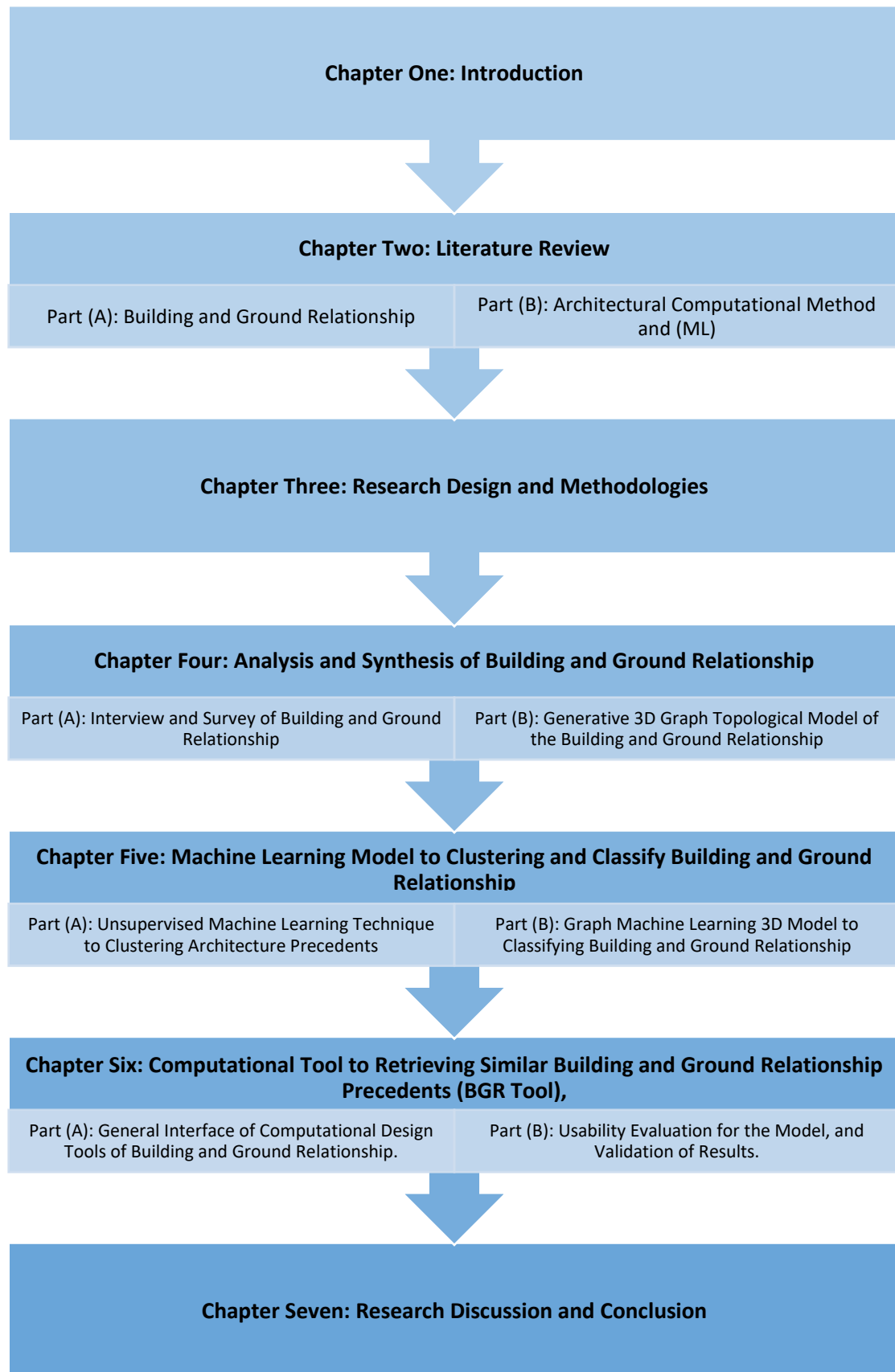

Figure 1.2: Structure of the thesis

Chapter 1: Introduction

Chapter One: Introduction and Overview	
<ul style="list-style-type: none"> - The Background and Nature of the Research Problem - Research Aim, Questions and Objectives. - Research Design and Methodology. 	
Chapter Two: Literature Review	
Part (A): An Exploration of Building and Ground Relationship	Part (B): Design Thinking and Architectural Computational Method
<ul style="list-style-type: none"> - Theories of the Ground and Building. - Toma Berlanda, A Graphic Lexicon of How Buildings Touch the Ground. - A Glance of the Architect's Way of reach the Building and the Ground. - Building and Ground Relationship Taxonomy. 	<ul style="list-style-type: none"> - Reviewing Design Models and Processes - Generative Design Processes. - Artificial intelligence and Machine Learning Models.
Chapter Three: Research Design and Methodologies	
<ul style="list-style-type: none"> - Research Paradigms and Theoretical Approach. - Research Design and Framework. - Phases of the Study and Research Methods. 	
Chapter Four: Analysis and Synthesis of Building and Ground Relationship	
Part (A): An Investigation of the Building and Ground Relationship	Part (B): Generative 3D Graph Topological Model of the Building and Ground Relationship
<ul style="list-style-type: none"> - Data Collection: Including Interviews, Image Archiving, and Image Sorting Survey. - Data Analysis. - Extracting/Validating the Building and Ground Taxonomy. 	<ul style="list-style-type: none"> - Data Collection: Image Archiving. - Data Analysis and the Extraction of Parametric Rules from Architectural Precedents. - Utilise Grasshopper to Create a Building and Ground Prototypical Design Pattern. - Generate a Large Synthetical Data Set of Architectural Building and Ground Precedents Using Topologic Software. - Label and Convert the Data Set into Semantically Rich Topological Graphs.
Chapter Five: Machine Learning Model to Clustering and Classify Building and Ground Relationship	
Part (A): Unsupervised Machine Learning Technique to Cluster Architectural Precedents	Part (B): Graph Machine Learning 3D Model to Classify the Building and Ground Relationship
<ul style="list-style-type: none"> - Create Unsupervised Machine Learning Model K-Means, K-Modes and GMM. - Analysis and Compare the Model Clustering Pattern. 	<ul style="list-style-type: none"> - Train the Deep Graph Convolutional Neural Network (DGCNN) Model for Graph Classification. - Prediction of a New Graph Building and Ground Relationship (Transfer Learning). - Train the Deep Graph Library (DGL) Neural Network Model for Graph Classification. - Train Unsupervised Graph-Level Representation Learning (UGLRL) for Graph Clustering.
Chapter Six: Computational Tool to Retrieving Similar Building and Ground Relationship Precedents (BGR Tool)	
<ul style="list-style-type: none"> - General Interface of Computational Design Tools of the Building and Ground Relationship. - Usability Evaluation for the Model and Validation of Results. 	
Chapter Seven: Research Discussion and Conclusion	
<ul style="list-style-type: none"> - Summary of Findings. - Contribution to the Body of Knowledge. - Limitations of Research. - Recommendations and Directions for Future Works. 	
Appendices	

Figure 1.3: Detailed Structure of the Thesis

CHAPTER TWO

LITERATURE REVIEW

Chapter 2: Literature Review

2.1. Chapter Overview

This chapter aims to review the building and ground relationship concept presented in (Part A), in addition to using computational and machine learning approaches that help address such concepts in the design process (Part B).

Part (A), "an exploration of building and ground relationships". Besides reviewing the literature, this section provides an analysis of the building and ground relationships. Section (2.2) addresses a theoretical overview of the building and ground relationship, and the study focuses on the last century. Section (2.3) reviews key concepts of architectural design and the built environment through a "non-discrete" building and ground relationship. Section (2.4) A glance review at the architect's way of reaching the building and the ground. Section (2.5) reviews Toma Berlanda, a graphic lexicon of how buildings touch the ground comprising two major taxonomies: the "main building and ground relationship" and the "building touches the ground"(Berlanda 2014). These taxonomies illustrate how buildings interact with the ground.

Part (B) explores the design thinking and architectural computational methods. Section (2.6) outlines major design models and processes. This review also examines the generative design process in Section (2.7). A computational design process is featured in Section (2.8). In addition, since the study focuses on machine learning, an overview of AI and ML is provided in Section (2.9). To determine the research gaps, the researcher reviews related studies on three major topics in Section (2.12): 1) studies concerning the relationship between the building and the ground; 2) studies using machine learning approaches to cluster similar architectural style precedents; and 3) studies dealing with the classification of architectural works using graph topological machine learning.

(Figure 2.1) summarises the literature review plan for the study, including the research problem, key terms and resources used to define the objectives and construct the research questions.

Chapter 2: Literature Review

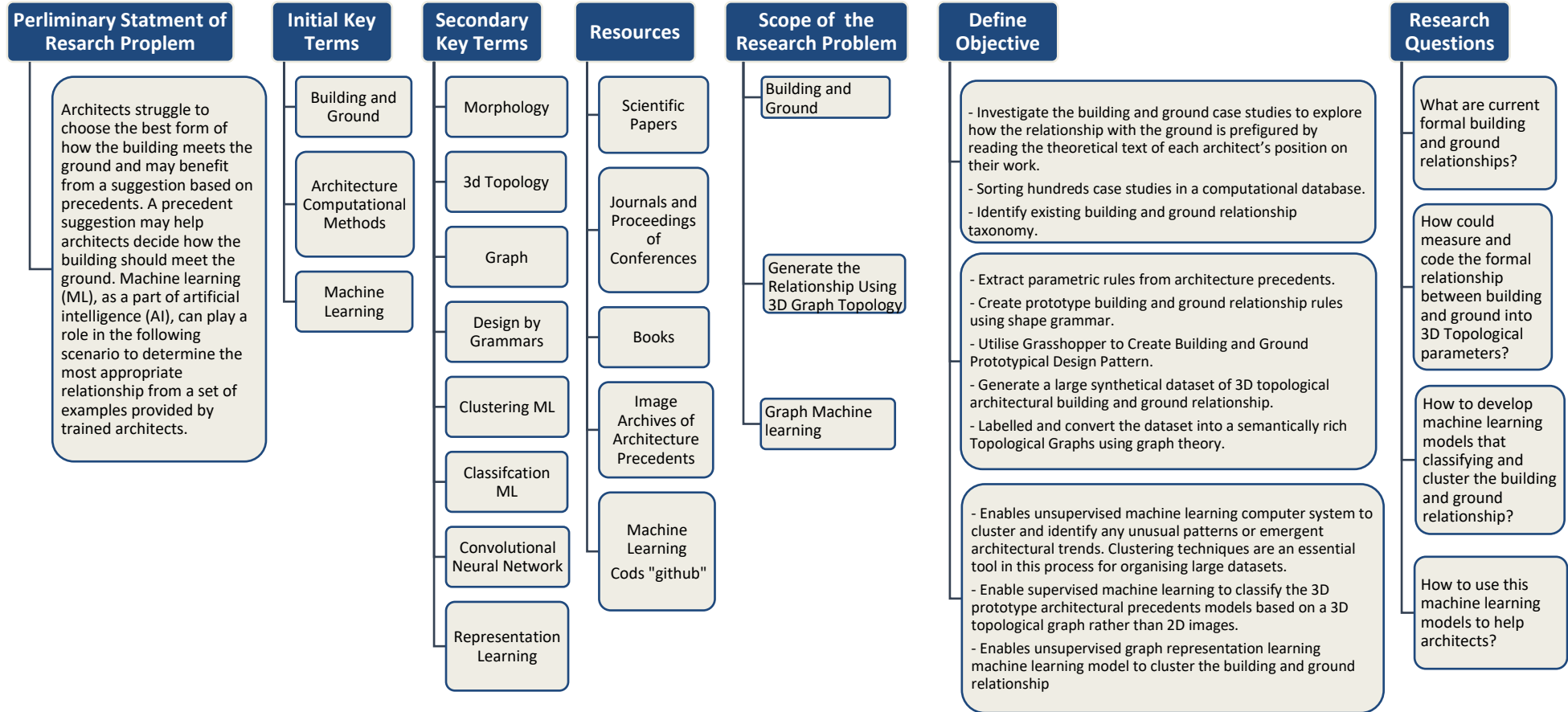

Figure 2.1: Summary of the literature review plan

Part (A) An Exploration of Building and Ground Relationships

2.2. Building and Ground Theories

Modern and contemporary approaches to the site show similarities with those historical precedents. Stan Allen and Marc McQuade, in "Landform Building: Architecture's New Terrain," argued that "In contemporary architecture, 'landform building' is much more than just a formal strategy. New technologies, new design techniques, and a demand for enhanced environmental performance have provoked a rethinking of architecture's traditional relationship to the ground." (Allen and McQuade 2011, p. 364). In 2012, during a discussion at Columbia University GSAPP in the ninth of a series of conversations between Peter Eisenman and Mark Wigley, titled "Wobble: The Cat Has Nine Lives," Eisenman crossed all the boundaries by saying, "Why do you have to go see the site? I never thought you got anything from seeing sites, but that's what they do. They have to go see the site. They take pictures of the site. They discourse on the site ... When I take my students on a trip, we never go see the site. We go and see other things—anything but the site⁽¹⁾". A review of building and ground theories in the last 100 years is presented in this section. The section is divided into three periods: modernism, post-war, and contemporary.

2.2.1. Modernism Period

Contrary to many critics, modern architecture cannot be generalised. In their study of the relationship between the building and the ground, Mies van der Rohe and Le Corbusier proved this idea (Figure 2.2). Some of their projects float above the earth's surface, while others construct new ground on the existing surface. According to Sanders, architecture continues to appropriate a responsibility once shared with landscape design (Sanders 2011). Most projects by Mies van der Rohe emphasise site boundaries and consider the surrounding context. In most of his early Interwar villas and post-war buildings, Le Corbusier choreographed an avenue that metamorphosed the ground plane for a cinematic experience.

The development of early architectural works based on the approach to the ground provides a principal idea within modern architecture and shows how it responded to new transformational technologies, transportation, and media (Porter 2016). Le Corbusier (1946) described the La Roche House using the term "architectural promenade". According to Leatherbarrow, redefining the boundary between the inside and the outside creates "a sense

⁽¹⁾ <https://www.youtube.com/watch?v=Gu4-ErX6hDA&t=4s> (accessed on 25/03/2019)

Chapter 2: Literature Review

of uneven continuity" that disintegrates the building unto itself as an object and reintegrates the building "into the horizons that transcend it" (Leatherbarrow 2000).

Richard Neutra and Frank Lloyd Wright sought to bridge the gap between architecture and the surrounding natural environment with a greater effect than Le Corbusier and Mies van der Rohe. According to Frank Lloyd Wright and Richard Neutra, through the clear formation of terraces, pool arrangements and level changes, architecture and the natural environment in modern architecture remain committed to horizontal surfaces as opposed to structural walls or frames to define architectural space (Figure 2.2). Regardless of the approach, differences exist between the two works presented by these authors.

Buildings by Frank Lloyd Wright, such as Johnson Wax Headquarters (1936) (Racine, Wisconsin), Larkin Building (1904) (Buffalo, New York), Guggenheim Museum (1959) (New York City), Robie House (1909) (Chicago, Illinois), Kaufmann House "Falling Water" (1939) (Mill Run, PA), Unity Temple (1909) and Wright's Home and Studio (1895) (Oak Park, Illinois), focus inward despite having terraces that sometimes extend beyond the site. On the other hand, Richard Neutra embraced expansive views of the distant landscape. According to Wright, "A building should appear to grow easily from its site and be shaped to harmonise with its surroundings if nature is manifest there. And if not, try to make it as quiet, substantial and organic as she would have been were the opportunity hers" (Wright 1975, p. 157).

Frank Lloyd Wright used metaphors of organic growth to describe his work, while Richard Neutra employed site design and artificial architecture. The combination of Frank Lloyd Wright and Richard Neutra's approach and that of Mies van der Rohe and Le Corbusier results in a matrix of modernist ground techniques (Porter 2016). There abound connections and contradictions within the matrix. Additionally, Richard Neutra connected the building using three main techniques: expansive view, dissolution and variations in levels. All these examples feature in examples such as Kaufmann House (1946) (Palm Springs, California), Rang House (1961) (Taunus, Germany), Josef Kun House (1936) (Los Angeles, California) and BEWO Estate (1960) (Walldorf, Germany).

Chapter 2: Literature Review

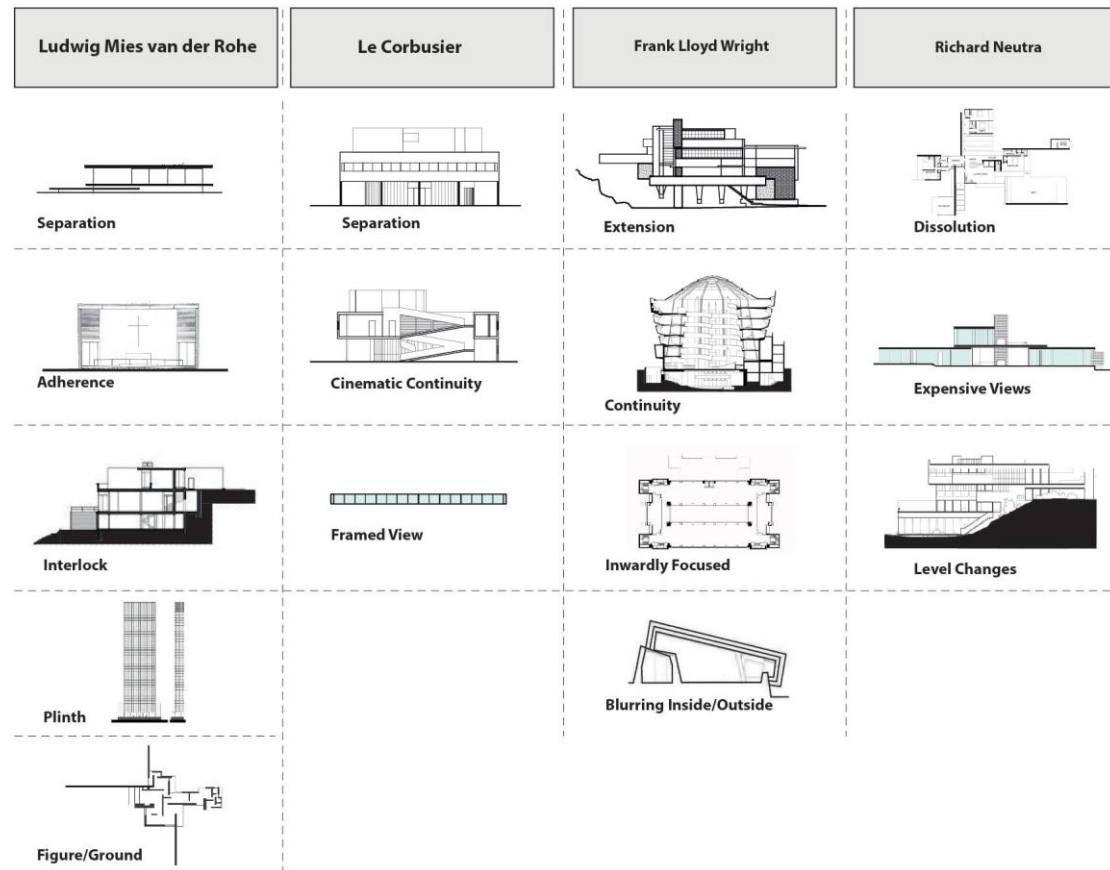

Figure 2.2: Modern pioneer architects' style of building and ground relationship (by author)

2.2.2. Post-war Period

After the mid-20th century, many architects proposed speculative designs, which removed structures from the surface of the earth and cast them in carefully choreographed travelling performances (Figure 2.3). John Hejduk's architectural masques, Aldo Rossi's Teatro del Mondo and Archigram's Walking City are classic examples of these mid-20th century architectures. From the perspective of post-war cultural products, these nomadic architectural speculations can only reflect the significant themes of late modernity. John Hejduk's career trajectory especially helps clarify the great potential of these nomadic architectural designs. For instance, in Hejduk's Lancaster/Hanover Masque (1983) in Germany, the structures have moveable wheels that allow locomotion in a ritualised geographic location. The detachment of Masque structures from the ground allows them to function as subversive agents in the cities they occupy. By understanding the political motivation that underpins Hejduk's detached figures, it becomes possible to plot a series of reference points that can aid contemporary architectural autonomy discussions.

During the 1980s, architects like Alexander Tzonis, Liane Lefaivre and Kenneth Frampton pinpointed new formal strategies, design techniques and technical problems related to the

Chapter 2: Literature Review

local architectural identity. These new designs included formalist indexical projects and fields and artificial ground projects (Figure 2.3). Two other radical groups, Archizoom and Superstudio, founded in the late 1960s in Italy, had the goal to explore field conditions in design. With their speculative projects, such as continuous monument and No-Stop City, they preempted the assumption that the only way to materialise architectural ideas is through discrete buildings. Their experimental drawings went beyond contained objects to describe expansive grids devoid of hierarchy and limits. Since the proposal of these radical projects, other architects, such as Peter Eisenman, experimented with different field conditions. Eisenman's career began in 1978 by working on indexicality and transformation themes through conceptual houses. However, his later projects reveal his transition from the object to the field. For example, in Eisenman's Cannaregio project, he superimposed three grid systems in an attempt to conduct an artificial excavation of the site's historical context. Another example of Eisenman's projects showing his transition to the field was the art museum project on the University of California campus. Eisenman's theory of design came from the desire to challenge the idea that the ground status acts as a stabilising element in contemporary society. Eisenman's ideas to deconstruct the perceptions of architectural sites resulted from the works of philosophers, such as Jacques Derrida, with the aim to construct new grounds rather than the pre-existing context.

From the mid-20th century, the site's status underwent a significant transformation in the U.S. with the emergence of new technologies. The relationship between space and time deteriorated. With the introduction of the atomic bomb in World War II (WWII), scholars argued that the traditional definition of "dwelling" could no longer be possible. In response, architects such as Hejduk and Eisenman produced speculative projects of late modernity. Other designers began to figure out how architecture could integrate new cultural conditions and traditional conceptions. One such attempt was Critical Regionalism, theorised by Liane Lefaivre, Kenneth Frampton and Alexander Tzonis. Under Critical Regionalism, the architect adopts aspects of modern design and considers the site conditions and the surrounding environment. However, the return to site-specificity was not an entirely architectural phenomenon. After WWII, other forms of art, such as dance and sculpture, left the museum gallery for direct engagement with specific sites. Post-war site specificity continues to raise pertinent questions, such as the status of the post-war ground, making an architectural work site-specific without nostalgia and so on.

Chapter 2: Literature Review

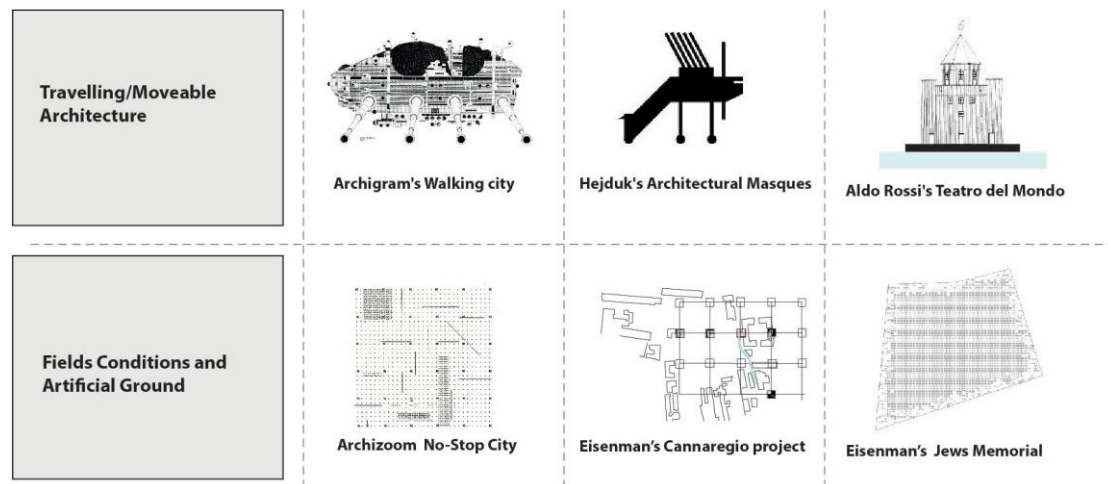

Figure 2.3: Two major Postmodernism approaches to the ground (by author)

2.2.3. Contemporary Period

At the beginning of the 21st century, architects precluded landscape as a model for future architectural practice. The underlying principles of the landscape model were largely theorised through publications and conferences on the themes of "Landform Building" and "Landscape Urbanism" (Allen and McQuade 2011). One challenge revolved around the implicit continuity of landscape not aligning with the realities of capitalist development in the 21st century and its requirements on the limits and boundary conditions (Porter 2017).

Upon realisation of this disparity, a section of architects decided to make a return to the autonomous object. The renewed attention to objects was also partially driven by the "Bilbao Effect," which occurs when a city's culture is transformed by an architectural icon which inhabits the city (Porter 2016). During the same period, Rem Koolhaas created polemical writings, which became the theoretical basis for buildings that existed as their own worlds. This thesis featured in the works of John Portman, an Atlanta-based architect and developer. In comparison to traditional urban approaches, John Portman's buildings turn inward, with more focus on substantial, multi-storey atriums as opposed to interactions with adjacent streets. However, the increased interest in the autonomy discourse raises questions about the role of architecture within society. For example, what is the political implication of buildings whose main focus is to separate themselves from the fabric of the urban set-up? Is it possible that an inwardly focused building could participate in local culture effectively? These kinds of questions have undergone close examination by Pier Vittorio Aureli, a theorist arguing that architecture must attest to its individuality for it to operate as a tool of change. The future of contemporary architectural practice finds itself in a state of flux, with landscape-buildings and object-buildings at odds. This situation serves to highlight the political and social dimensions

that colour the relationship between architecture and the city. Wiscombe (2014) affirmed that building mass maintains distinction from the ground rather than fusing or disappearing into it. Strategies such as nestling, hovering or differing landing create intensive coherence rather than literal continuity (T. Wiscombe 2014).

2.3. Key Concepts of Architectural Design and The Built Environment Through "Non-Discrete" Building and Ground Relationships

According to Hensel and Turko (2015), efforts should be made to reignite spatial thinking, discourse, and design in architecture alongside identifying the traits of what can be described as an architecture intensively embedded in the local context. In other words, a non-discrete architecture eschews the disengaged object as the primary objective of architectural design (Hensel and Turko 2015). Several theoretical reflections and discussions related to key concepts and potentials of non-discrete architecture design are presented here.

2.3.1. Open the Architectural Space to the Surrounding Landscape

A prevailing trend in current architecture design emphasises the connection between space and gardens and landscapes. Bernard Tschumi, for example, argued that "gardens merge the sensual pleasure of space with the pleasure of reason, in a most useless manner" (Tschumi 1990). Moreover, the Japanese architect Kengo Kuma, who considered architecture as an independent object, argued that the ground should be "an autonomous figure cut off from the ground — a garden is a continuum, the ground itself" and stated that "we must aim for a wilderness rather than garden" (Kuma 2008). Kuma's aim was described in the Spidenethewood (2007) project by R&Sie(n), located in Nimes, France (Figure 2.4). The dense vegetation covers the building and promises the idea of non-discrete architecture (Hensel and Turko 2015).



Figure 2.4: *Spidernetwood* (2007) project by R&Sie(n) (Source: <https://new-territories.com/spidernet2.htm> , Accessed: 19 June 2019).

According to Collins, Frank Lloyd Wright was the first architect to introduce the concept of space into architectural works. "It was he who, at the beginning of the century ... first exploited the spatial possibilities which had lain dormant since the end of the Baroque and applied them to buildings appropriate to the new age" (Collins 1998). David Leatherbarrow's analysis of Frank Lloyd Wright's work described "the dissolution of bound space in plan as defined by the planes and corners of walls, in favour of a continuous space that is particularised in section" (Leatherbarrow 2000). Wright elaborated on the condition by saying, "*Architecture now becomes integral ... in integral architecture, the room-space itself must come through. The room must be seen as architecture, or we have no architecture. We no longer have an outside as outside*" so the "*inside space opening to the outside and the outside coming in*" (Wright 1955, p. 69). The relationship between the architecture and the surrounding landscape offers a starting point for non-discrete architecture (Hensel and Turko 2015).

2.3.2. Integrating Between the Landscape and Architecture

The integration between the landscape and architecture brought with it a significant development. According to Alex Wall, "*These works signal a shift of emphasis from the design of enclosed objects to the design and manipulation of larger urban surfaces ... this is landscape as an active surface, structuring the conditions for new relationships and interactions among*

Chapter 2: Literature Review

the things it supports" (Corner 1999, p. 233). Eventually, Leatherbarrow resolved the dialectic argument between architecture and landscape design by having the architect and landscape architect work together on a set of shared tasks without dividing the task. Leatherbarrow also repositioned the overlap between architecture and the landscape, suggesting topography as their shared element (Leatherbarrow 2004).

This case study focuses on the integration of architecture and landscapes in the first half of the 20th century. For example, the Usonian house (1937), designed by Frank Lloyd Wright, Villa Savoye (1992), designed by Le Corbusier, Mies van der Rohe's most prominent terraced houses, Rudolph Schindler's work by Richard Neutra, and Aalto's work can all be considered outcomes of a relationship with the ground. Moreover, at the end of the 1970s, Steven Holl identified the topic as one of the vital nodes of the relationship between architecture and place. According to Holl, "the relation between things is the focus, rather than the object-type. The zero points of such a relation is a section at the surface of the earth" (Holl 1988, p. 128). The Y House in the Catskills Mountains (1997-1999) exemplifies this statement (Figure 2.5). Furthermore, Holl argued that "in the ground, on the ground and over the ground. The portion over the ground is suspended, cantilevered above the portion in the ground" (Holl 2007, p. 75).



Figure 2.5: Y House in the Catskills mountains by Steven Holl, 1999
(Source: <https://www.stevenholl.com/project/y-house> Accessed: 20 July 2019).

Chapter 2: Literature Review

2.3.2.1. The Relationship Between the Landscape and Modern Architects

The relationship between the landscape and buildings has expanded and attracted modern architects, historians, and theories. In his essay, "human/nature: wilderness and the landscape/architecture divide," Joel Sanders discussed both examples of Le Corbusier's Villa Savoy and Mies van der Rohe's Farnsworth House. According to Sanders, the reason for lifting the building is to preserve the ground's sanctity. In addition, it frames an expensive view of the landscape (Balmori and Sanders 2011). Jeffrey Kipnis argued that the purpose of lifting the building was political: Le Corbusier lifted his buildings into the air to restore the land to its natural state. Although his idea appears naive today, it paved the way for a century of attempts to find more poetic and psychological means to disentangle buildings from land as a form of power (Kipnis 2013). According to this explanation, Kipnis interpreted the formal and physical relationship between the building and the landscape as "a symbol of political expression". His theory took inspiration from recent architectural experiments, such as Archigram's Walking City and John Hejduk's architectural masques (Porter 2015).

Frank Lloyd Wright, one of the most prominent modern figures to integrate the landscape with the building, responded with his point of view on a modern house by saying, "First, a good site. Pick that one at the most difficult spot—pick a site no one wants—but pick one that has features making for character; trees, individuality, a fault of some kind in the realtor's mind." In "Uncommon Ground," David Leatherbarrow analysed the relationship between buildings and their sites. According to Leatherbarrow, these architects show an interest in blurring the boundary between architecture and the landscape. Additionally, Leatherbarrow argued that "the clear boundary between inside and outside was radically redefined, in order to develop a sense of uneven continuity that would both disintegrate the building as an object unto itself and reintegrate it into horizons that transcend it" (Leatherbarrow 2000, p. viii).

2.3.2.2. Landscape-Inspired Projects

During the 1980s and 1990s, several built landscapes or landscape-inspired projects began to appear. Examples of this concept or approach appeared at the Parc de la Villette competition in Paris (1983) and the Downsview Park competition in Toronto (2003). Recent developments have included the notion of engaging the constructed ground in association with envelopes in order to establish space. For instance, the Brazilian Pavilion for the Osaka World Expo (1970), designed by Paulo Mendes da Rocha, reflects the relationship between nature and construction (da Rocha et al. 2007). A related topic was the growth of interest in the continuous surface idea, which is the idea of using the ground as a continuous ground of events. In 1965, Claude Parent and Paul Virilio developed the oblique function surface (Figure

Chapter 2: Literature Review

2.6), allowing the continuous surface to become a usable and inhabitable space (Johnston 1996).

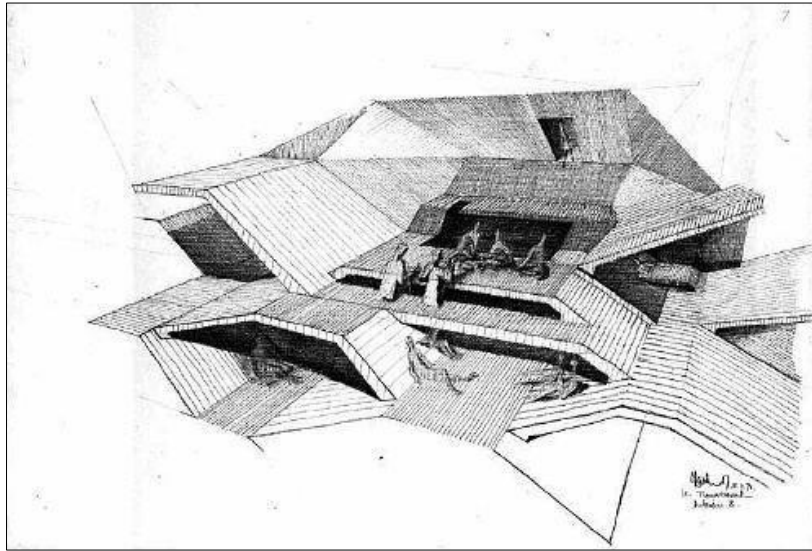

Figure 2.6: *Oblique function* by Claude Parent and Paul Virilio (Source: <https://alchetron.com/Claude-Parent#demo> Accessed: 1 July 2019).

2.3.3. Technology and Bearing Structures

Recently, technological developments have allowed architects to use materials and load-bearing structures without the need for traditional foundation platforms. Moreover, technology offers an inexpensive way to move the earth and disrupt the ground configuration. Therefore, a new vocabulary has become more common for objectifying the noun "ground," such as raised, stacked, carved, and exposed. These adjectives have extended the meaning of adjustments operated by architecture to engage the building and the ground.

2.3.4. Term of Topography

Architects, art historians and landscape architects have agreed that the term topography no longer refers solely to geometrical aspects of a site, such as a slope and orientation, but to everything comprising it, including history, geography and geology. To create the topographic dimension and the relationship of architecture to the ground, Rosalind E. Krauss explored the edges between the landscape, architecture and sculpture. David Leatherbarrow argued that "topography is the topic (theme, framework, plan) architecture and landscape architecture hold in common" (Leatherbarrow 2004, p. 1). Therefore, Leatherbarrow defined the meaning of topography by declaring that it is not restricted to the natural qualities of a site but includes built and unbuilt terrain (Leatherbarrow 2004).

2.4. A Glance at the Architect's Way of Reaching the Building and the Ground

It has become clear that architects can employ different methods to reach the ground in their work. In some cases, architects repeat the same idea without considering the ground underneath them. Some architects, however, remain passionate about engaging the site's unique features and characteristics in their concepts and decision-making (Berlanda 2014). For example, in 1942, Rudolph Schindler constructed Harris House on an existing rock, which served as the foundation for the site (Figure 2.7). However, Rudolph Schindler's King Road house (1922) (Figure 2.8) rests on the earth without adapting to the ground (Berlanda 2014). All of Rudolph Schindler's houses and ideas fit the argument that the ridge should never be crossed but hugged by the flank, becoming part of its surroundings, and leaving the main lines of the mountain untouched (Schindler et al. 2001).



Figure 2.7: Rudolph Schindler embeds Harris House.

(Source:<https://www.stevewallet.com/blog/2011/10/19/rm-schindlers-rose-harris-house-1942-introduction-part-1-of-5>, Accessed: 12 June 2019)



Figure 2.8: Rudolph Schindler King Road House

(Source:<http://www.yellowwooddesign.com/blog/2013/5/17/rudolph-schindler-the-kings-road-house.html>, Accessed: 12 June 2019)

Chapter 2: Literature Review

Rudolph Schindler defined his concept of three houses. He defined Walker House (1929) (Figure 2.9) as "caving down a slope," Wolfe House (1928) (Figure 2.10) as "balancing above the hill," and Van Patten House (1935) (Figure 2.11) as "rising up against the hillside" (Sheine et al. 2001). Smith Elizabeth and Michael Darling described Rudolph Schindler's Wolfe House thus: "no excavating was done to speak of, instead of digging into the hill the house stands on tiptoe above it" (Schindler et al. 2001, p. 39).

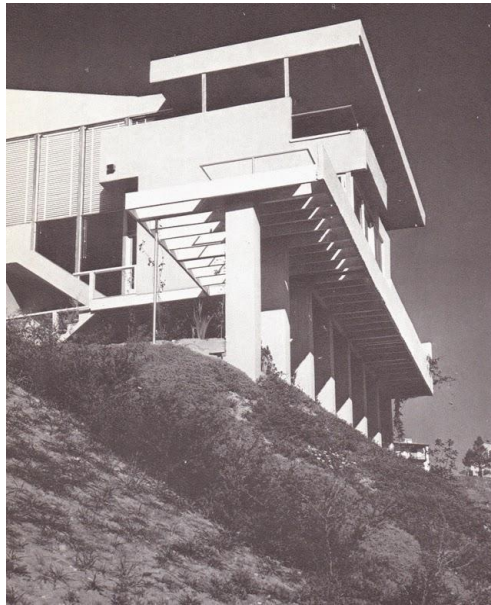

Figure 2.9: Walker House (Source: <https://esotericsurvey.blogspot.com/2014/10/shnidler-bonhams.html>, Accessed: 13 June 2019)



Figure 2.10: Wolfe House (Source: <https://esotericsurvey.blogspot.com/2014/10/shnidler-bonhams.html>, Accessed: 13 June 2019)

Chapter 2: Literature Review



Figure 2.11: Van Patten House (Source: <https://www.cosmicinspirocloud.com/post/124514699157/r-m-schindler-van-patten-house-moreno-drive>, Accessed: 13 June 2019)

In La Tourette Church (1956), Le Corbusier implemented a strong integrative relationship with the ground (Figure 2.12). In one part, the church is built on the ground; in the other part, it is built on a slope. The church is lifted off the ground, meaning the basement can intermediate the levels (Arnold and Cling 2002).



Figure 2.12: La Tourette, Le Corbusier (Source: <https://www.archdaily.com/96824/ad-classics-convent-of-la-tourette-le-corbuier>, Accessed: 13 June 2019)

The Norwegian architect Sverre Fehn engaged two contradictory concepts relating to the ground: the plinth method in which "the earth is covered by a foundation" and digging around the building to reveal "the secrets of the underground" (Norberg-Schulz and Postiglione 1998). Many houses of American architect John Lautner seem to rise from the earth, but "he was

Chapter 2: Literature Review

equally effective at dissolving the relationship between house and ground altogether" (Cohen et al. 2008, p. 19). It remains notable that most of the hillside houses designed by Luigi Snozzi (Figure 2.13) comprise one solid volume obstructed by the ground while the other appears to rest upon a carpet (Snozzi et al. 1995).



Figure 2.13: Casa Bernasconi, Luigi Snozzi 1989-90

(Source: https://commons.wikimedia.org/wiki/File:Carona_32w.jpg, Accessed: 16 June 2019)

In his Kiro-San observatory (1991), the Japanese architect Kengo Kuma excavated the pre-existing hill and inserted the building to become part of the topography (Figure 2.14). "To restore the mountain peak, he conceives architecture like a hole instead of an object" (Kuma 2005, p. 14). Looking the other way, Kuma's Floor Forest house (2001) (Figure 2.15) floats from the ground. Conversely, at Soba Restaurant (2002), part of the building rests on the ground while the other remains separate from the ground (Figure 2.16). Separation constitutes the prevailing method in Glenn Murcutt's building. However, he uses interlock methods too, such as Ockens House (1982) (Figure 2.17). Glenn Murcutt stated that the method used in his design depends on the climate (the level of heat and humidity). He said, "if you lift the house off the ground the snakes go underneath it, the elevation allows you to watch for termites." (Glenn 2012, p. 509).

Chapter 2: Literature Review



Figure 2.14: Kiro-San observatory by Kengo Kuma

(Source: <http://negativearchitecture.blogspot.com/2009/02/forest-floor-great-bamboo-wall-ginzan.html>, Accessed: 16 June 2019)



Figure 2.15: Forest Floor by Kengo Kuma.

(Source: <http://negativearchitecture.blogspot.com/2009/02/forest-floor-great-bamboo-wall-ginzan.html>, Accessed: 17 June 2019)

Chapter 2: Literature Review



Figure 2.16: Soba restaurant by Kengo Kuma (Source: <https://kkaa.co.jp/en/project/soba-restaurant-at-togakushi-shrine/>, Accessed: 17 June 2019)

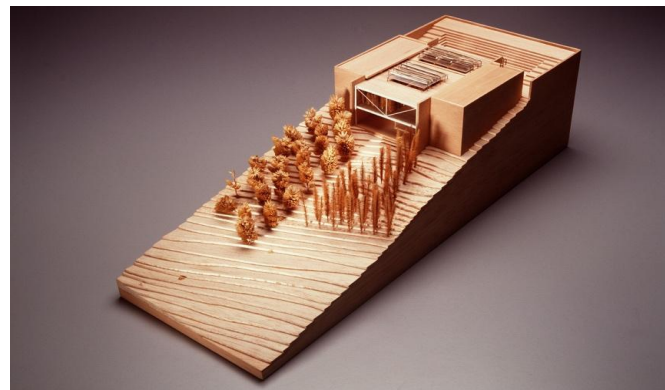

Figure 2.17: Ockens House by Glenn Murcutt's (Source: <https://collection.maas.museum/object/166826>, Accessed: 17 June 2019)

A Berlin project, Topographie des Terrors (1993), follows the ground while retaining its autonomy (Figure 2.18). Zumthor (1997) referred to it as "an elemental manifestation of architecture intermeshed with topography". On the other hand, slender supports lift the Briol hotel expansion in Barbican off the ground like a "treehouse on stilts".



Figure 2.18: Topographie des Terrors by Zumthor (Source: <https://www.berlin.de/mauer/en/sites/other-key-sites/topography-of-terror/>, Accessed: 19 June 2019)

2.5. Toma Berlanda, A Graphic Lexicon of How Buildings Touch the Ground (Building and Ground Relationship Taxonomy)

Buildings have numerous ways of meeting the ground. There are three main building and ground relationships: Adherence, Separation and Interlock. All the other approaches must fit into one of these three main categories (Berlanda 2014). The ground has several definitions referring to how a building touches the ground and the ground's physical features. The ground has duplicity of meaning in several languages. The variety of interpretation can be taken as a suggestion of the multiple points that one must address (Berlanda 2014).

2.5.1. The Main Building and Ground Relationship

2.5.1.1. Separation Approach

Naturally, a building cannot be abstracted from the earth completely, but the contact between the two elements can be limited to specific points to free the building from the horizontal plane of the ground below. This unbuilt interstitial area can be viewed as part of the building or as part of the ground beneath it. Either way, the space underneath separates the two parts and gives the impression that the building floats. This method clearly distinguishes the load-bearing structure and the lower buildings supporting it, creating a feeling of the earth being left undisturbed. Tectonic solutions are also better understood from this vantage point. The separation may owe to technicalities like isolation, dampness, floods and animals or more practical issues, such as funding or environmental concerns.

A Farnsworth glass house by Mies van der Rohe is the first proposal of a building not attached to the ground (Figure 2.19). Resor House was designed as a bridge uniting two banks, a "floating self-contained cage" as Johnson puts it (Figure 2.20). Farnsworth House is not dissimilar, built on a site where floods often occur. In these instances, separation from the ground is simply a solution to the site's problems.

Chapter 2: Literature Review



*Figure 2.19: Farnsworth House by Mies van der Rohe
(Source: <https://www.architecturaldigest.com/story/mies-van-der-rohe-farnsworth-philip-johnson-glass-house> , Accessed: 2 July 2019)*



Figure 2.20: Resor House by Mies van der Rohe (Source: <https://www.artstation.com/artwork/8eg6Jq> , Accessed: 25 June 2022)

Chipperfield Museum, meanwhile, is built up and above the ground across the river's floodplain, creating a ground plan that moves beyond the building and "forms a raised platform reminiscent of those found in the Japanese temples" (Chipperfield 1994, p. 111). Referring to the "floating syndrome of the modern era," Herzog and de Meuron deplored these architectural trends, claiming that the pilotis in Rudlin House in Laymen (1995-7) (Figure 2.21) is not designed for support purposes but symbolic ones: the building sits on a horizontal plane serving as something like a "sedan chair" or "flying carpet" (Ruff 1995). This approach can be found on a hill as a "grey monolith left behind by the last ice age". The house expresses its "desire of separation from the ground" by sitting on a horizontal surface before an incline

Chapter 2: Literature Review

(Fernndez Galiano Herzog & de Meuron., 2019). This effect is achieved by cantilevering one side while metal columns buttress the remaining three.

The notion of "taking possession" of the ground is refuted by Paulo Mendes da Rocha, who considered it "synonymous with theft and destruction". When asked whether buildings detached from the ground are central to his thinking, he wrote that "not touching the soil was never a stylistic issue because building-raised enclosures is a way of preserving the ground ... leaving the terrain in nature can mean a lot today." (Artigas 2007, p. 248).



Figure 2.21: Rudin House, Leymen by Herzog & de Meuron (Source: <https://arquitecturaviva.com/works/casa-rudin-leymen-3> , Accessed: 25 June 2022)

2.5.1.2. Adherence Approach

Adherence refers to a building that sticks to the ground or lies like a carpet on the terrain. Buildings laid on terrain do not comprise the sole instance of adherence; attention must be paid to other ways in which the earth is organised, including the use of light consolidations or thin platforms to serve as artificial groundwork that traces the building's contour lines (Berlanda 2014). The area that joins topography with both the ground and the building constitutes a floor extension rather than a raised platform, a feature ensured by the lack of level change between the artificial horizontal plane and the floor, the area between the exterior and interior floors and the lack of paving joints (Berlanda 2014). Research conducted by Jacobsen stretched from the Bellavista Complex (1931-4) to Rodovre City Hall (1956) (Figure 2.22), with the latter lying "flat on the earth like a toppled skyscraper" (Thau and Vindum 2001), tracking the behaviour of the terrains beneath these buildings. As well, a lying

Chapter 2: Literature Review

skyscraper approach is currently used in a smart linear city under construction in Saudi Arabia, Neom (Figure 2.23). The linear city design has a similar approach to Rodovre City Hall but on a larger scale. As Bamboo Wall House (2002), Kuma writes: *"The slanted topography of the site is left intact, and a slender architecture built directly onto the undulating ground ... the level of the ground is varied according to the topography. A linear wall-like structure appears as though it is crawling on the landform, avoiding land reclamation and maintaining the complex topography"* (Kuma 2005, p. 108).



Figure 2.22: Rodovre City Hall by Arne Jacobsen Source: <http://copenhagenbydesign.com/rdovre-city-hall> , Accessed: 23 June 2022)

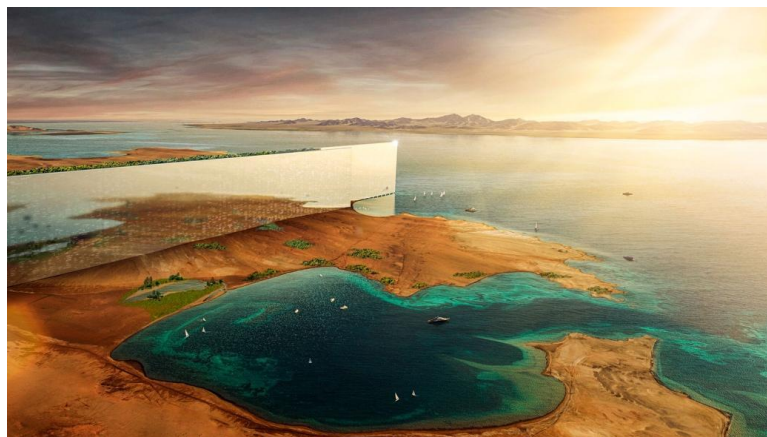

Figure 2.23: The Line City Neom Source: <https://www.neom.com/en-us/newsroom/hrh-announces-theline-designs> , Accessed: 4 August 2022)

2.5.1.3. Interlock Approach

Defined as "becoming locked together or interconnected,". Interlock refers to a configuration of the ground with the construction while sharing a space that sees them complement one another (Berlanda 2014). Interlocking can help resolve technical problems by eliminating the change in level and fillet contour lines. For example, in Solar Hemicycle House by Frank Lloyd Wright (1943-1948), the excavation soil created a landfill resting on the building's wall that

Chapter 2: Literature Review

generated a passive heating system (Riley and Reed 1994). Other examples of the interlocking approach were demonstrated in Kauttua (1937), managed via a service vane that worked as a basement along the hillside. This structure was created through several stepped volumes appropriately connected to the construction. Orense (1967) explored university halls and focused on interlocking solutions for sloped buildings, all of which relied on particularly positioned prefabricated modules (Berlanda, 2014). Using the "glacier morainic" terraces and soil from earlier excavations, Alvar Aalto formed an elevated central court in Saynatsalo (1949-52). An elevated open space was built using the ground floor's inner walls to retain some of the foundation's original material (Weston 1995). The Fallingwater captures Wright's method of determining how the building appeared to grow from the natural. Wright integrated the weekend home design with the waterfall by placing the house directly above the waterfall to make the waterfall a part of Kaufman's life. Wright interlocked the building with the waterfall ground so that the house could not exist without the waterfall and vice versa.

2.5.2. The Building Touches the Ground:

2.5.2.1. Grounded/Ungrounded

The term "of the ground" refers to the physical quality of the earth's crust. The symbolic meaning of the ground is the foundation, which is the starting point of all thought and construction. "To ground" is an English verb used to define the connection between the building and the ground. However, ungrounded means something that is off the ground. Ungrounded refers to a building detached from the earth with no connection to the specific location, meaning it can be replicated anywhere (Rajchman 2000). The attention to the earth's physical properties led the architect to respect and explore two strategies. The first group of architects tends to minimise the groundwork, soil excavations and movements. The second group emphasises the construction processes and tries to lead them in a new direction (Berlanda 2014).

The theoretical Robert Smithson's showed a deep concern with the "earth surface and the figments of the mind transformation processes" (Smithson 1996, p. 100). Robert Smithson was amazed by the number of disruptions in the site, digging engines and crawlers that moved over the terrain and steep slope. This distribution led Smithson to think about why some architects hate bulldozers and steam shovels (Smithson 1996). Sean Godsell shared this thought by saying, "never trucking soil away from the site. What is of the site, is of the site" (Godsell and Van Schaik 2005, p. 23). Furthermore, Godsell developed a set of construction details to reduce harmful impacts on the ground. For this reason, Godsell started to use steel

Chapter 2: Literature Review

structures that were inserted carefully into the earth. On the other hand, there is an opposite school of thought who prefers to dig in the ground. Many of Enric Miralles' works were intended to excavate the ground. For instance, the scars on Igualada's cemetery (1985-92) look visible on the ground and "not even the stones were extracted from the quarry by means of labour but through explosion" (Berlanda 2014, p. 58).

2.5.2.2. Foundation

The meaning of foundation, as a singular noun, refers to building elements that can make a way through terrain to reach a steady layer to transmit the building loads (Deplazes 2005). Moreover, foundations, as a plural, means a set of principles working as the basis for a science or discipline. Luigi Snozzi argued that "a building always begins with the foundation" (Snozzi et al. 1995). He also claimed that foundations can be indicated as traces and footprints that no longer remain.

Richard Neutra's research aimed to change conventional foundation approaches, which he developed in his prototypes. Neutra also showed awareness that "foundation is proverbially-essential in all human concerns, but even the most ingeniously conceived shop-fabricated structures rest on footings, rather clumsy" (Richard Neutra 1951, p. 14). In many of Neutra's works, the foundation constitutes the crucial element to appreciating the styles of touching the ground. Therefore, using the concrete layer, the footing in the ground and the vertical supports become an essential part of Neutra's design (Berlanda 2014).

2.5.2.3. Plinth

A plinth comprises a portion of the earth's crust with a dissimilar thickness that acts as a base (Wright 1973). A clod is a portion or mass of earth, while a plinth is a layer with different consistency that acts as a base (Berlanda 2014). Whether it is a notion of natural or geological creation or artificial, the plinth is a form of support belonging to the earth and the building simultaneously. Moreover, the plinth is not only cladding or slab of the ground but also a fundamental component of the project (Berlanda 2014).

In many examples of Mies van der Rohe's work, including the Neue Nationalgalerie in Berlin, the Seagram Building in New York City and the German Pavilion in Barcelona, he used a plinth to define and separate the building from the site's context. Frank Lloyd Wright did not build above the earth directly but attempted to build with the ground because it "is a component basic part of the building itself" (Wright 1973, p. 94).

Chapter 2: Literature Review

Plinths on an urban scale can extend more than the one building footprint to become incorporated within the pre-existing and surrounding city. Juan Navarro Baldeweg stated that the ground is a crucial layer that requires manipulation, and the topography becomes the conceptual, rather than physical, level he used to frame his distinction from the city. Furthermore, Peter Rich's Mapungubwe Interpretation Centre (2008) took its design and construction material inspiration from the surrounding landscape. This inspiration gave the building continuity with the city (Berlanda 2014). The domes were built using native soil, and stone masonry was added to the surface and rested on a plinth, which heritagized the complex to its location. Using the existing material from the surrounding area suggests that it "erupted from the earth in a geological event which created the mesas of the site and Mapungubwe hill" (Berlanda 2014, p. 63).

2.5.2.4. Artificial Ground

Artificial ground refers to thin man-made material designed to raise the building from the ground. "We are not touching the ground, the earth we are building on is artificial. It is made from us" (Arets et al., 2002, p. 119). Artificial ground is neither embedded in the earth nor set on pilotis. It is merely placed on the ground. Le Corbusier discussed in offensive terms the ground's physical features, and he outlined the natural ground as "a dispenser of rheumatism and tuberculosis" (Le Corbusier 1967, p. 56). Thus, he perceived and created an artificial ground. The subject of the building's connection to the ground underwent definition by Herzog and de Meuron, mindful of the difference between artefact and nature. Herzog and de Meuron argued that "to build, to occupy the earth, first entails a new artificial ground" (Wang et al. 1990, p. 2).

2.6. Building and Ground Taxonomy

The taxonomy was developed based on Bernales's 2014 book "Architectural Topographies: a graphic lexicon of how buildings touch the ground", which contained a theoretical text. According to Berlanda, the relationship between buildings and their surroundings can be classified into four categories. The first category is the main building and ground relationship, namely, separation, adherence, and interlocking. The second category is how the building meets the ground, which consists of foundations, plinths, and artificial ground. The third category is related to terrain, which includes topography, landing and grounding, strata, and earthwork/landform. The fourth category is the metaphorical relationship, which includes rooting, anchoring, resting and feet in the ground. In order to rationalise and streamline the building and ground relationship, this section focuses on the first two Berlanda categories,

Chapter 2: Literature Review

which describe the physical building and ground relationship. Two categories exist, namely, the main building and its relationship with the ground and the buildings that touch the ground. Additionally, the study contributed to this taxonomy by developing abstract diagrams for each category and approach in the form of figures to assist in understanding the taxonomy (Figure 2.24).

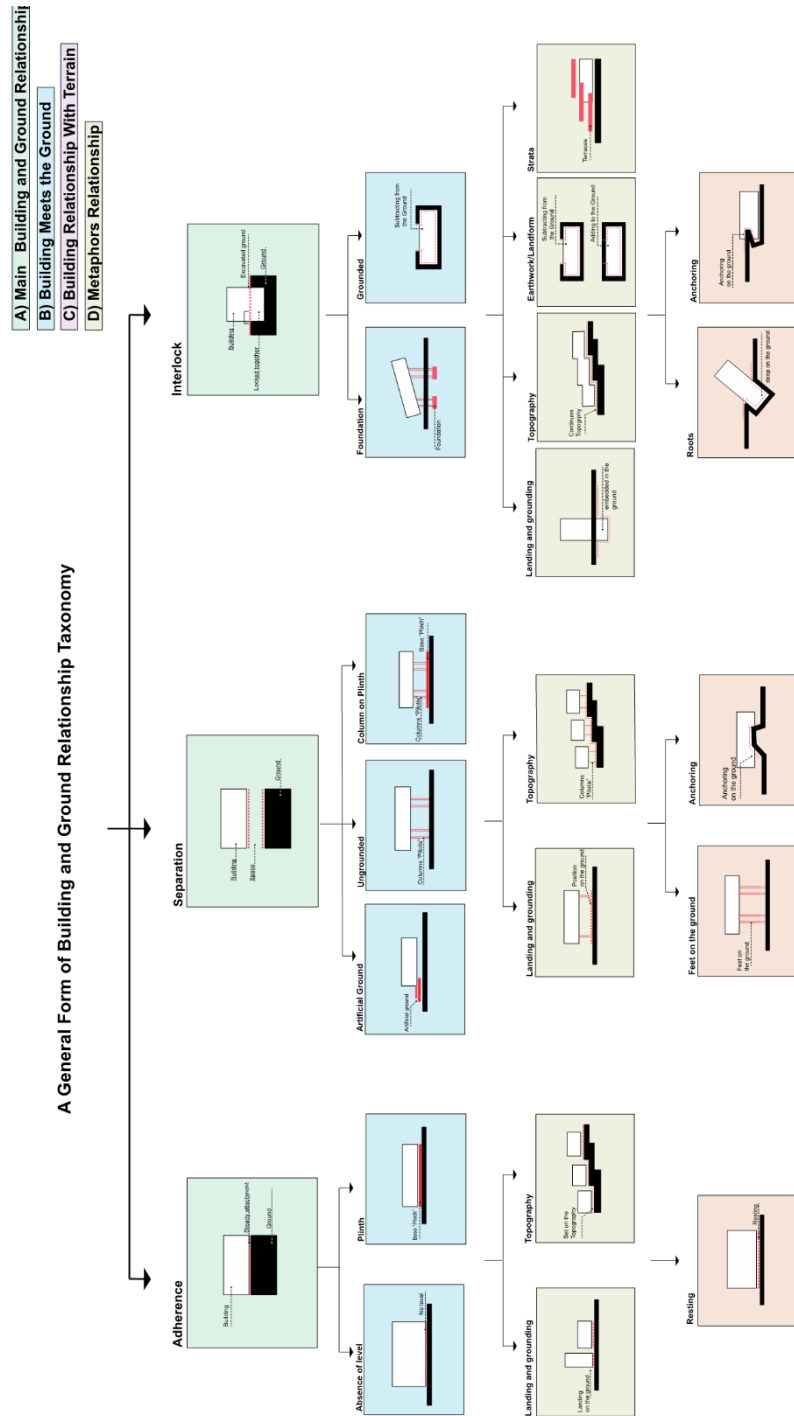

Figure 2.24: A general form of building and ground relationship taxonomy (by author after Berlanda 2014)

Part (B) Design Thinking and Architectural Computational Methods

Designing contemporary buildings that consider the ground as early as possible requires a thoughtful approach that incorporates the existing situation, the design requirements and the architect's needs. Generating and evaluating the outcome of such a complex process, which involves numerous design parameters, requires a systematic procedure for generating and evaluating the outcome in terms of the building and ground relationship qualities. Therefore, using computational analysis and design models makes it easier to manipulate. Additionally, artificial intelligence and machine learning can assist designers in achieving these goals, and they will play an increasingly crucial role in future design practices.

This part examines different design models and processes to determine which approach proves most appropriate for achieving the study's objectives. Furthermore, an understanding of the relationship between the elements of architecture can improve with an overview of different analytical and generative systems.

2.7. Reviewing Design Models and Processes

A review of different design models and processes is presented in this part. In spite of the fact that this part is general information, it is certainly very informative since it provides key contextual information to the intended audience, which is peer academics, students and lecturers interested in computational design methods.

"Design" has a wide range of meanings. According to (Heskett 2005), "design is to design a design to produce a design". In the design process, data is collected, analysed, designed, tested, and evaluated to arrive at a decision. Moreover, this design requires exploring various solutions before selecting the best option (Krish 2011). The following stages comprise the process of architectural design (Figure 2.25):

Phase(1) Defining the design problem.

Phase(2) Collecting the data to clarify the situation.

Phase(3) Analysing the collected data through brainstorming (sketches, diagrams, and images).

Phase(4) Developing a solution and building a test model.

Phase(5) Discussing the different solutions to gain feedback.

Phase(6) Improving the selected solution.

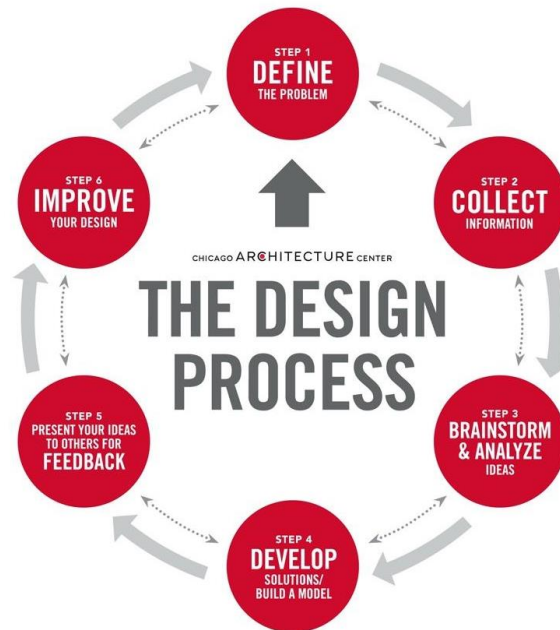

Figure 2.25: The process of Architectural design (Source: <https://discoverdesign.org/handbook>, Accessed: 9 January 2020).

To better understand the design philosophy, different paradigms and models could undergo implementation to achieve the design requirements. These models comprise the analysis synthesis model, the conjecture-analysis model, the abduction model, modular systems, and the computational thinking design model. The process of thinking and exploring creative solutions varies according to each model.

2.7.1. The Analysis Synthesis Model:

The analysis synthesis model is also referred to as a problem-solving process. In other words, the design comprises an activity that aims to solve problems. In 1962, Christopher Jones and Christopher Alexander presented the first paper on design methods at a conference in London. During the design process, they divided it into two phases: analysis and synthesis. They defined this approach as "the process of inventing physical things which display new physical order, organisation and form, in response to function" (Alexander 1964, p. 1).

The model begins with the analytic phase, which comprises three stages:

1. Using mathematics to break a problem down into components known as minor subsystems that are as independent as possible.
2. Organising them into a hierarchy and combining them into subsystems.
3. Identifying "patterns" from the surrounding environment that meet each component's requirements.

Chapter 2: Literature Review

The second phase synthesises these elements into a whole. A hierarchical and rational decomposition of the problem allows the designers to shape the various components of the new structures (Cross 2001).

In 1963, Bruce Archer introduced another approach to help design problems systematically. He contended that solving a design activity requires a model that represents the intention to create a product with creative steps without using an automatic process (Cross 1984). The problem-solving process comprises three interrelated elements: external representation, activity and problem-solving (Mahmoodi 2001). Six stages overlap with various feedback loops: programming, data collection, analysis, synthesis, development, and communication (Cross 1984) (Figure 2.26).

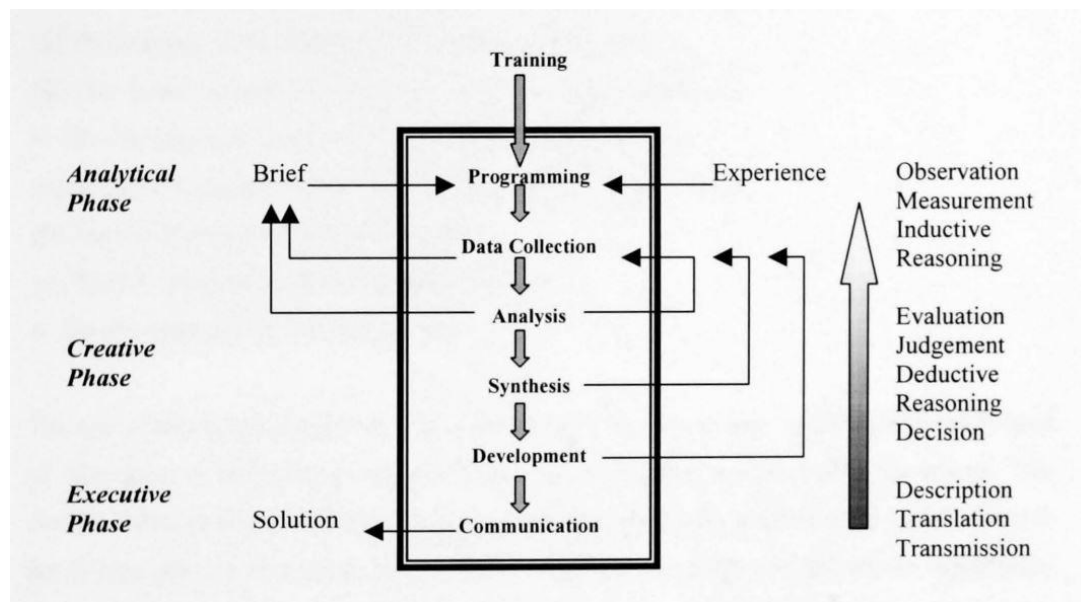

Figure 2.26: A model of a design process based on Archer's work (Mahmoodi 2001).

The real world rarely provides perfect and complete information, and designers cannot wait until they have conducted a thorough analysis (Archer 1984). In this regard, the designer's experience and knowledge from historical cases offer vital evidence, which can reduce the effort needed for the problem-solving process and enable more rational decision-making (Cross 1984). In Archer's view, "if the solution to a problem arises automatically and inevitably from the interaction of the data, then the problem is not, by definition, a design problem" (Cross 1984, p. 4). Using this design model can efficiently solve well-defined problems without searching for a single unique or perfect solution. Evidence suggests that architectural design should take a more innovative approach to find the best and optimum solution rather than simply a process of problem-solving (Maani 2014).

2.7.2. The Conjecture Analysis Model:

The second design management model is predicated on the idea that conjectures prove necessary for the advancement of science. Karl Popper initially proposed this theory in 1963, and other academics, including Bill Hillier and his colleagues, accepted it in 1972.

Scientists may learn from their errors. In 1989, Popper said in the fifth edition of his book "Conjectures and Refutations: the growth of scientific knowledge" that they should test the hypothesis and disprove it rather than attempt to prove it. If the scientist cannot disprove the hypothesis or make a prediction based on it, then it is regarded as a theory (Popper 1962). To appreciate the challenges of the issue and to refute a theory, one must criticise conjectures. This approach brings the scientist closer to the truth.

For instance, a project, which represents a challenge in the design field, has an infinite number of potential solutions. Before the design process begins, two sets of limiting criteria, according to Hillier's model, cut down this range of options (Figure 2.27). First, "external variety reducing constraints" comprise factors beyond the designer's control. These factors include customer preferences, standards for appearance, the availability of technology tools, prices, and other aspects. This kind of restriction may be deterministic in nature. The second group is "internal variety reducers" and includes manifestations of the designer's mental model and his comprehension of solutions (Hillier 1972). Using the same concepts, Jane Darke (1979), quoted in Groat and Wang (2013), suggested a "Primary Generator Model" that consisted of three stages: Generator, Conjecture and Analysis. The model helps the designer to provide a focused solution and frame the issue to make it easier to handle. Based on this approach, early hypotheses require testing to satisfy the project's requirements.

This design process paradigm is distinct from the analysis-synthesis approach in several ways. First, the analysis aims to evaluate hypotheses rather than optimise the information. Second, this paradigm allows for solutions at earlier design phases. Thirdly, this paradigm is comparable to the situation in science where a halt must occur at some point since both knowledge and conjectured answers are fundamentally imperfect. Finally, the conjecture analysis model emphasises how the designer pre-structures the issue and comprises an interactive design process rather than systematic or linear methodologies (Hillier 1972; Mahmoodi 2001).

"Design in Architecture: Architecture and the Human Sciences," showed he was another academic who embraced Popper's Model (Mahmoodi 2001). He identified four categories of "design conjectures" that impact design solutions: pragmatic, typological, analogical and

Chapter 2: Literature Review

syntactic. For instance, an analogy, metaphor or inspiration might introduce conjectures (Hillier 1972). The designer then looked at how these hypotheses (spaces) matched up to several criteria, including how well they suited activities, environmental filtration, cultural symbolism, economic performance, and environmental effect (Broadbent 1973, as quoted in Mahmoodi 2001; Maani 2014).

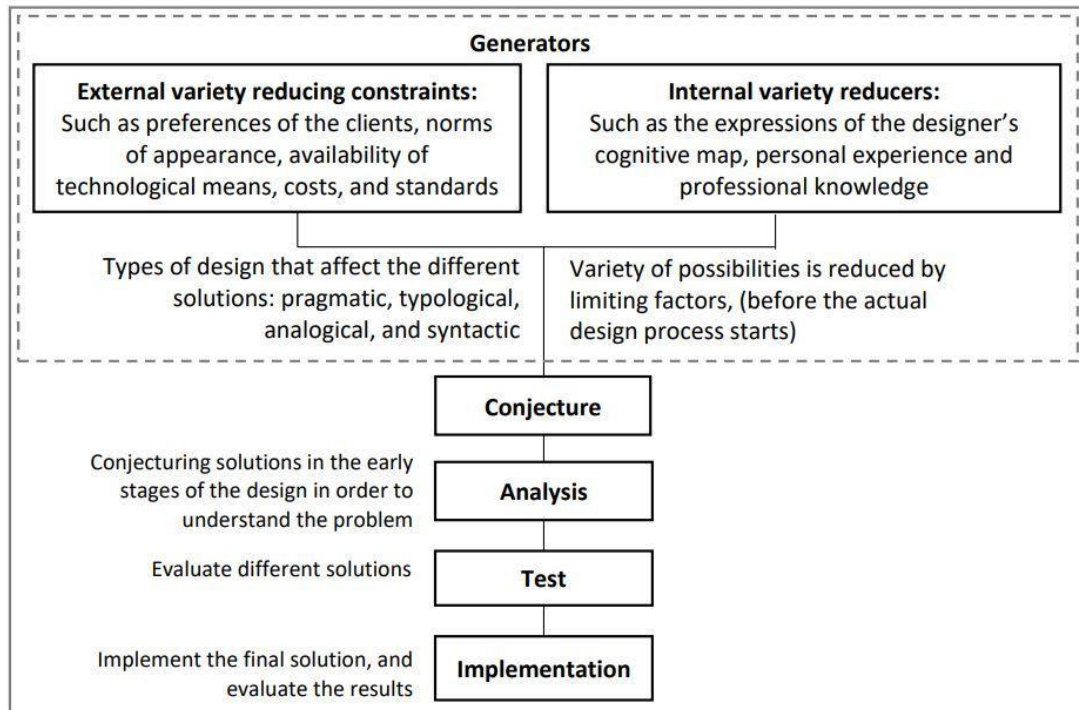

Figure 2.27: Design as a scientific knowledge: the conjecture-analysis test model

Using this scientific framework, Jon Lang (1987) described the design process as an argumentation process and included conjectures and the assessment of these conjectures in his book "Creating Architectural Theory: The Role of the Behavioural Sciences in Environmental Design" (Mahmoodi 2001).

2.7.3. The Abduction Model

This model is also known as a testable design hypothesis. Abduction is a kind of philosophical reasoning that may create a hypothesis verifiable by more information (Johansson 2003). Depending on its interpretation, it could result in accurate or inaccurate results. The American pragmatic philosopher Charles Sanders Peirce (1901) developed the idea of abduction in his work on the "Logic of Drawing History from Ancient Documents," notably from "Testimonies" (Johansson 2003). He referred to it as "guessing". According to Peirce, "deduction" generates a "result based on a rule and a case," whereas "induction" serves as the conclusion of scientific reasoning (Peponis et al. 2002). In other words, to infer a hypothetical explanation 'a' from an

Chapter 2: Literature Review

observable occurrence 'b' is to assume that 'a' may be true but is not essential for 'b' since it is a given.

In the area of architectural research, Nigel Cross (2011) noted that abduction is a helpful technique employed by design researchers for transferring ideas between the necessary functions and suitable forms to achieve that objective (Groat, and WanG 2013). The designer developed a fundamental concept for a solution using this method. The architect then developed a shape and incorporated fresh concepts using hypothesis logic. The testable outcomes acquired by deduction might help choose conjectures using induction. New forms then undergo evaluation in relation to design limitations, goals and needs. By understanding the issue, designers can better generate parallel lines of reasoning for solutions. In other words, it proves tricky to define a design challenge without considering a solution (Cross 1984). An "open form" of abductive methodology was presented by Kees Dorst (2011) and is appropriate for the conceptual design stage. Designers must identify the starting point of the problem-solving process (the "what") and the working principle (the "how") that leads to the desired value in the model, namely "what (thing) and how (working principle)" lead to "Value".

There are two areas where this model and the "conjecture-analysis model" diverge. First, the abduction model is based on logical and mathematical reasoning, but the conjecture-analysis model is based on the designer's prior knowledge and professional experience, known as the "Heuristic Method" (Hudson 2010). Second, designers may use the abduction model to develop fresh ideas. The speculation model, however, takes into account known solution types. The speculation model considers known solution types (Maani 2014).

The researcher believes that the abductive model represents the most appropriate approach for the present study since it begins with gathering data and ends with developing initial assumptions and alternatives that might undergo testing to obtain the desired conclusion (Figure 2.28). However, the result of the analytical procedure can prove to be a novel answer that was not anticipated. These designs represent a reaction to a complex collection of aesthetic, social and physical constraints that also comprise the community's local character.

The researcher may lack the capacity to handle this complexity and identify the best answer using the typical manual manipulation of spaces. Therefore, adopting computer-controlled methods that consider numerous characteristics and restrictions may prove a suitable strategy. The notion of computational design undergoes discussion in the following part, along with several analytical and generative techniques that may enable the researcher to translate the challenging into workable options that meet the desired goal.

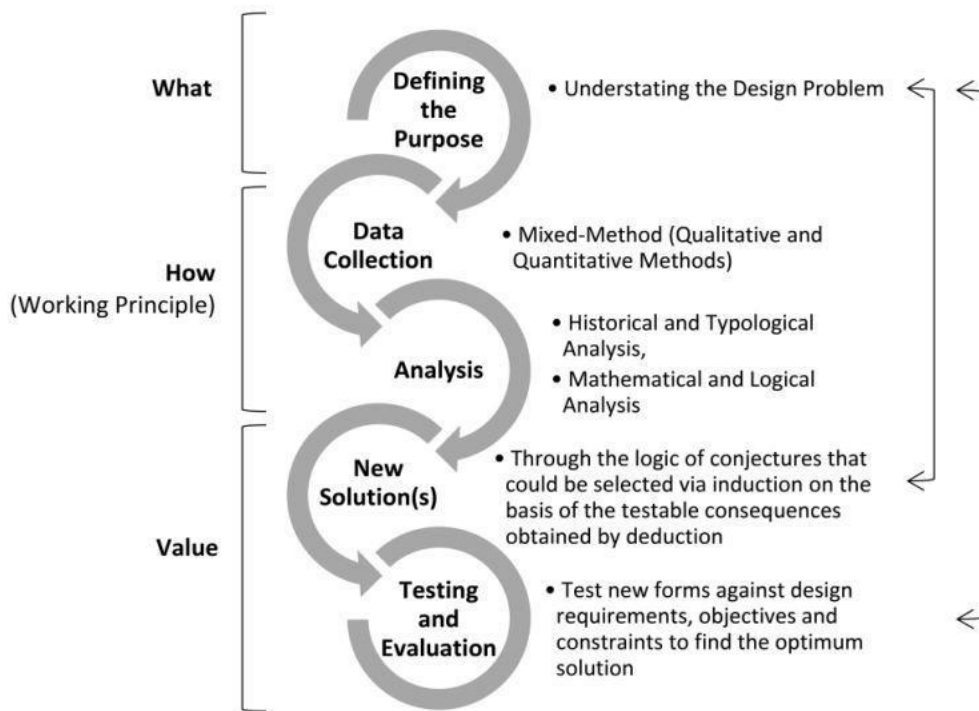

Figure 2.28: The open form of the abductive model (Al-Jokhadar 2018)

2.7.4. Modular Systems

Modularity may be considered the starting point for systematic and mathematical architectural design. Through rationalising and simplifying, modular systems contribute significantly to the design of buildings. Modularity first appeared as a subject of discussion for academics and practitioners. In 1920, Walter Gropius applied the modular grid in the Bauhaus to simplify the technicality of the building and reduce the cost. Gropius implemented the concept of "Modularity" in several projects. A Bauhaus notion was exhibited in 1923 entitled "Big Construction Kit" (Baukasten im GroBen) for developing serial houses. "Big Construction Kit" was designed by Gropius and his partner Adolf Meyer (Seelow 2018). Additionally, Gropius considered the idea of aggregating modules through assembly rules.

One year later, Le Corbusier applied the modular system to a human scale. This "Modulor" was a holistic implementation of the modular principles (Figure 2.29). The "Modulor" was advanced to combine human form, architecture and beauty in a single system. Le Corbusier applied the Modular concept from Unité d'Habitation (1947) to La Tourette (1956), which was the built environment dimensions derived from the human ratios.

Chapter 2: Literature Review

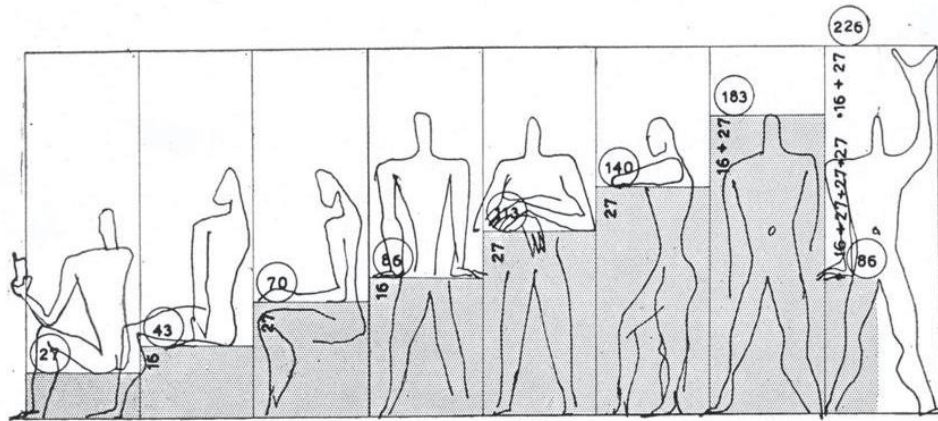

Figure 2.29: Le Corbusier's Modulor (Source: <https://www.lescouleurs.ch/en/journal/posts/the-modulor-human-closeness-as-a-basic-value/>, Accessed: 13 January 2020).

Buckminster Fueller developed modularity as a proof-of-concept for the industry in 1946. Fueller's Dymaxion House was an autonomous single-family dwelling using sustainable technologies and was easy to assemble and mass-produce. Fueller provided an idea of advanced prefabricated modules (Figure 2.30).

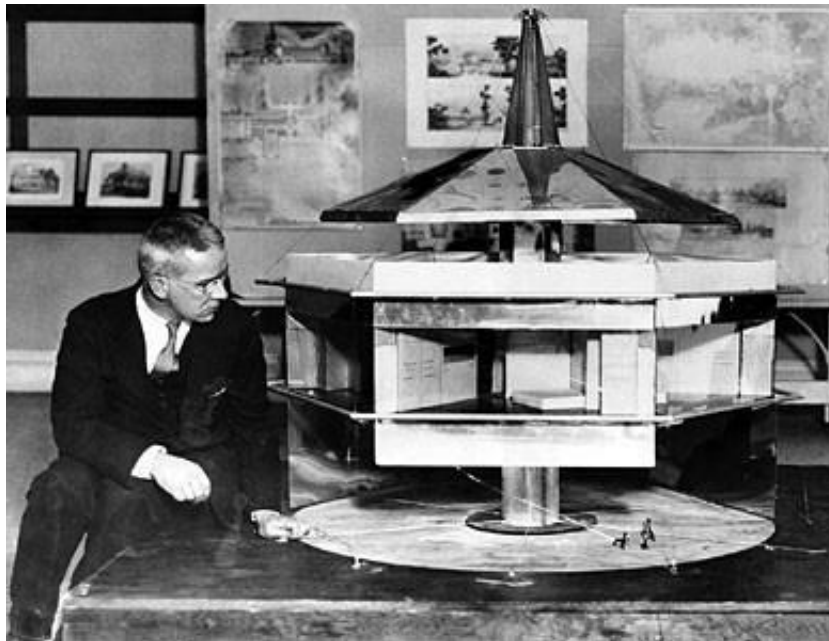

Figure 2.30: Buckminster Fueller Dymaxion House (Source: <https://www.archdaily.com/401528/ad-classics-the-dymaxion-house-buckminster-fuller>, Accessed: 13 January 2020)

On the other hand, modularity also applies to industry and practice. In 1933, Professor Robert W. McLaughlin built Winslow Ames House, which was less hassle, less costly, easier to assemble and more predictable. This innovative house comprised several modules, with the bathroom, kitchen, plumbing and heating systems connected to the service core. Gunnison developed his "Add-on" modules in 1950 and used them in his famous Gunnison Homes.

Chapter 2: Literature Review

These houses consisted of steel frames with customisable features that could extend the houses to create supplementary spaces such as porches, porticos or garages (Figure 2.31).



Figure 2.31: Gunnison Homes (Source: <https://99percentinvisible.org/article/modularity-modern-history-modular-mass-housing-schemes/>, Accessed: 14 January 2020)

Modularity fascinated architects during the 1950s. For example, architect George Nelson's experimental house concept merged new materials, such as plastics, with the space-age futurism Nelson was famous for (Wagner 2016). In the early 1960s, Guy Dessauges created capsule houses, which provided large open windows offering panoramic views. In 1964, modularity reached a sophisticated level of complexity with the Plug-In City by the British avant-garde group Archigram (Figure 2.32). The biggest prefabricated modular megastructure was Habitat 67, built by Moshe Safdie for the 1967 Expo in Montreal. Habitat 67 comprised up to 12 floors, including 354 identical precast concrete apartments arranged in various combinations (Figure 2.33).

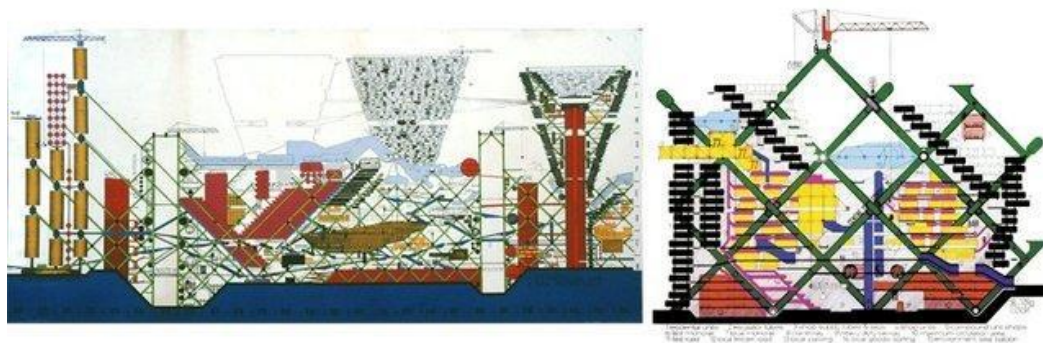

Figure 2.32: Plug-In City, Archigram's. (Source: <https://www.archdaily.com/399329/ad-classics-the-plug-in-city-peter-cook-archigram>, Accessed: 15 January 2020).

Chapter 2: Literature Review



Figure 2.33: Habitat 67, Moshe Safdie. (Source: https://en.wikipedia.org/wiki/Habitat_67 , Accessed: 14 January

Japanese Metabolist concepts, such as Archigram, do not go beyond the theoretical stage. However, some buildings reached the construction stage, such as the Nagakin Capsule Tower by Kisha Kurokawa (1972). Modularity, however, remains alive through its system of rules. Technological advancements prompted a new generation of architects to return to experimental modular housing. For example, the Klip House by Interloop, a computer-designed set of parts, could be snapped together like LEGOs. Klip House was designed to appeal to families looking for a detached home that could adapt to their changing needs. Container City II by CMGlee is another example of a contemporary modular house, where ship containers are repurposed into small homes.

2.7.5. Computational Thinking and Design Process

Computational design involves using computers to manipulate ideas, concepts and interactions among design elements (Terzidis 1994). In a mathematical and abstracted framework, computation forms a logical and dynamic design process resembling the human mind (Hall and Kibler 1985). The primary topic of computational thinking involves determining how to use computation to understand the world. Using a competition model as an experimental method can clarify what has happened, to class a model that describes phenomena that people see daily or a model that helps to predict the future. Science has moved from the physical laboratory space to the computer. Increasingly, science has relied more on computer-based experimentation than traditional experimentation. According to Chaillou (2019), an architect adopts a computational design for the following reasons: (1) increasing design reliability, feasibility, and cost by controlling design geometry; (2) facilitating designer collaboration; and (3) the ability to test and choose better-resulting designs with more iterations than with traditional hand-sketching methods. A computational system for building design comprises four main components: 1) inputs, which refer to conditions and geometric properties of shapes (parameters); (2) rules and algorithms that provide mechanisms for generating solutions; (3) the outputs that determine the design solution; and (4) selecting the most appropriate solution (Dino 2012a). The architect must have the ability

Chapter 2: Literature Review

to think mathematically and algorithmically to implement the computational system (Woodbury 2010).

2.7.5.1. A Parametric Design Approach (Thinking Mathematically)

(Woodbury 2010; Lee et al. 2014), defined parametric architecture as using mathematical expressions and operations to generate multiple solutions. Variations provided by parametric design can extend exploration to creative solutions. (Jumelet 2013), explained how this process correlated with abstraction, which means breaking things down into their basic shapes to determine their fundamental structure. According to Woodbury (2006), this process in parametric design uses a data-flow model to calculate unknown results from specific knowledge. In the data flow, nodes represent objects, and arrows symbolise relationships. Various types of arrows represent the relationships between objects.

Typically, information flows from independent to dependent nodes. An example of a plan that consists of three rooms (room #0, room #1 and room #2) could be illustrated as nodes with different geometric relationships between their width and height. According to (Figure 2.34), $w(1)$, $w(2)$, $h(0)$ and $h(2)$ comprise independent variables, while $w(1)$, $w(2)$, $h(0)$ and $h(2)$ comprise dependent variables.

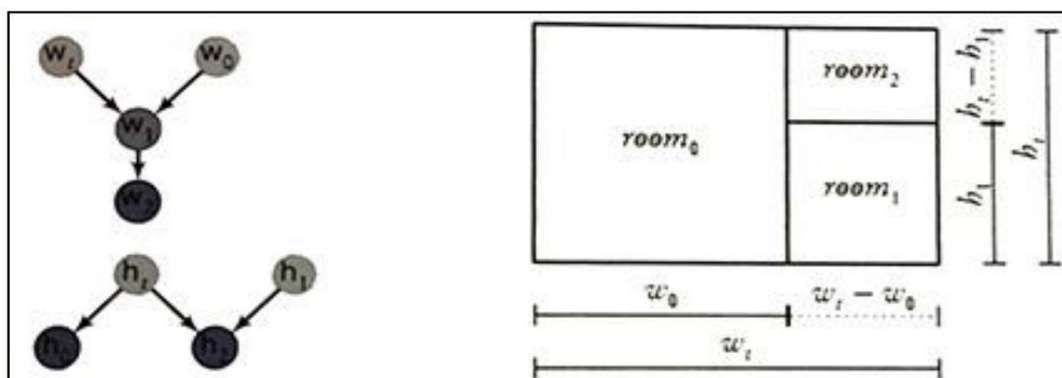

Figure 2.34: An example of the 'propagation-based system' (Woodbury 2010).

Such a process has analytical and generative uses, including validating the logic of the problem and generating new forms and different alternatives interpretable in numerous ways (Nirosh.L 2021).

Parametric models give designers the ability to incorporate all design objectives and relationships between objects as a set of rules and algorithms. This approach contrasts with traditional computer modelling, which requires designers to study the problem with all its constraints. Due to the model's ability to respond and manipulate the design geometry, different alternatives and prototype solutions can be generated within a short period (Dino

Chapter 2: Literature Review

2012; Jabi 2013). A significant advantage of this interactive form-finding method is that it allows the user to adjust parameters and rules at any stage to generate unique and unrepeatably solutions (Correia 2013; Jabi 2013; Serra Fernandes 2013; Oxman and Gu 2015). According to Kheiri et al., the most crucial solutions for the architect involve determining the optimal design based on specific parameters (Kheiri et al. 2013). In this regard, other external simulation tools could be used, or computers could explore solutions and report the most appropriate alternatives.

2.7.5.2. An Object-Oriented Programming (OOP) Approach (Thinking Algorithmically)

Algorithms are "a finite set of instructions that aim to fulfil a clearly defined purpose in a finite number of steps" (Dino 2012, p. 220). Designers perform a finite series of specified steps and rules intelligently and precisely by converting inputs into different solutions and outputs (Woodbury 2010; Dino 2012). Using the arithmetic and logical capabilities of computers, this process involves deduction, induction, abstraction, generalisation, and structured logic (Terzidis 2006). Nevertheless, algorithms are not limited to well-defined problems with predetermined outcomes (Yüksel 2014). Numerous problems have unknown or ill-defined solutions, according to Terzidis (2006). In this case, when computers explore potential solutions, algorithms become the best approach. This algorithmic computational process creates and modifies objects using object-oriented programming (OOP), a programming paradigm used to create and modify databases (Jabi 2013). An object consists of (a) data, in the form of fields, often called "attributes", like edges, centres or names that identify it, and (b) code, in the form of procedures and algorithms that modify the attributes of the object, known as "methods". A "class" or "family of objects" is created when objects share attributes or characteristics (Jabi 2013). A class comprises three components: a name, attributes and operations (Nirosh.L 2021).

In his book "Elements of Parametric Design," Robert Woodbury (2010) argued that parametric systems (algorithms) are implemented through precise and prescribed programming languages. There are different components to each language (Terzidis 2006; Jabi 2013):

- Values: objects have values that determine their attributes. There are many types, including constants, integers, real numbers, characters, strings and booleans. Some values, however, can be functions, which derive their value from other attributes belonging to other objects.
- Variables: symbolic representations of containers that hold changing values. They are called parameters in parametric design, which are opposites of constants and have a range

Chapter 2: Literature Review

of possible values. Depending on the variable in a function, another measure or value could be determined, as the form but not the general nature of a function is determined by it.

- Operations or Expressions: combinations of values, variables, operators and functions that return values.
- Statements: codes that require execution in a particular order. A loop, for example, consists of three parts: an initial condition, a termination condition, and a repetition statement.
- Control statements: such as "if" and "switch" statements providing a list of possible actions based on the value of a variable. The "for-loop" repeats a block code until the loop condition is met, in which it calls an initialiser for a control variable.

Despite this development, architects find it challenging to apply this algorithmic process because it requires an understanding of scripting and programming languages. Grasshopper, developed by David Rutten at Robert McNeel & Associates in 2011, allows detailed control of complex geometry generation through mathematical functions within Rhinoceros 3D computer-aided design (CAD). Grasshopper is a visual scripting tool that does not require any programming knowledge. It is possible to pass input data between components via connecting wires, which store data as parameters (Figure 2.35).

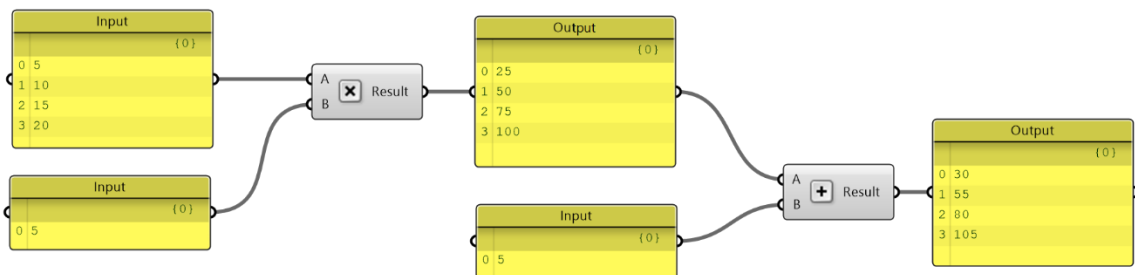

Figure 2.35: An example of how Grasshopper processes mathematical functions (by author)

2.8. Generative Design Processes

2.8.1. Grammar as an Analysis Tool and Generative Design

'Design by Grammar' refers to the generative process of considering the morphology of the form and the components of the internal structure, relationships and processes that generate it (Eilouti and Al-Jokhadar 2007). Design grammar emphasises syntactical and lexical constructions rather than semiotics and semantics. This section explores the potential of using grammar as a tool of analysis and generator of new solutions through implementing rules and constraints on the initial shape.

2.8.1.1. Shape Grammars

Shape grammars utilise generative rule-based systems for describing and generating designs (Stiny 2006). Shape grammars allow the designer to understand and generate designs by working with a shape in two or three dimensions rather than words, numbers and symbolic computations. In the early 1970s, George Stiny and James Gips (1972) conducted studies in this area. The systematic formulation of spatial relationships, parameters, rules and restrictions can create a language of design to analyse existing shapes and create new alternatives (Stiny and Gips 1972; Bonacic et al. 1977; Stiny and Mitchell 1978; Stiny 1980a; Stiny 1980b). The formalism for shape grammars aims to offer a user-friendly and understandable experience while also adapting to computer programmes at the same time (Bonacic et al. 1977). Stiny uncovered the four elements of shape grammar: a finite number of shapes, a finite number of symbols, a finite number of shape rules and an initial shape (Stiny 1980a). To avoid spatial ambiguity, Stiny introduced a labels system (such as letters, symbols, and points) associated with shapes to control the process of generating design alternatives.

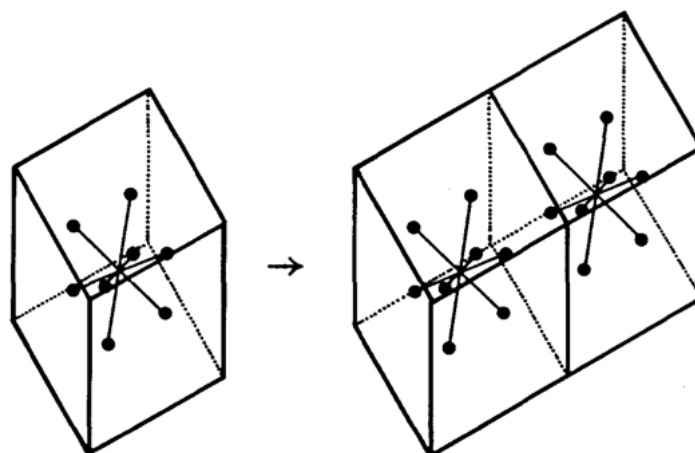

Figure 2.36: Labelling a cube to prevent spatial ambiguity

Chapter 2: Literature Review

This labelled system with the "parametric grammars" could be applied to the shapes, and new solutions could be created using parameters set within the limits of the grammar derived from changing the values of the parameters in the grammar (Figure 2.36). (Stiny 1980a).

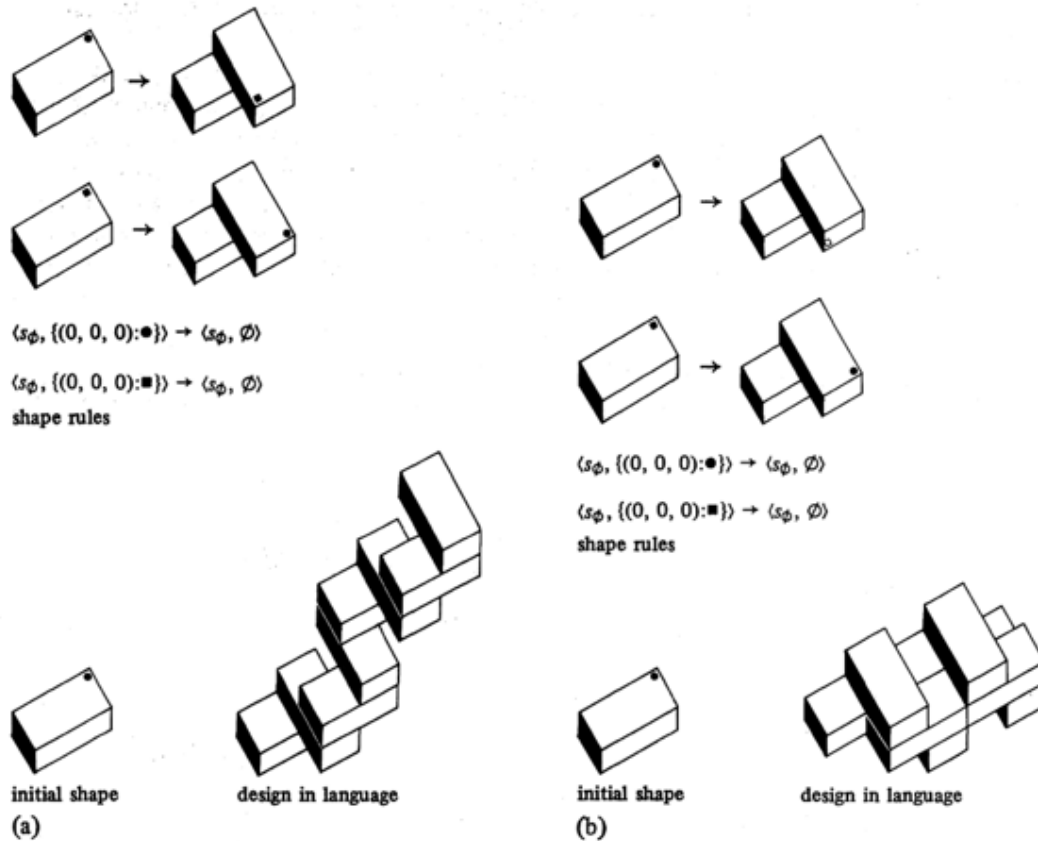

Figure 2.37: Labelling a cube to prevent spatial ambiguity

Since shape grammars do not go into the semantics or semiotics of the layout, they cannot show the historical, social, cultural, economic, or environmental context of the composition (Colakoglu 2005; Knight and Stiny 2015). Besides, the limitation of shape grammars in relation to producing designs has no architectural meaning or lacks relevance. Therefore, to counter these limitations, the authors suggest combining shape grammars with different descriptions and textual information (Figure 2.37).

2.8.1.2. Description Grammars

According to Stiny (1981), the details of design elements are typically provided in text and descriptions. For this reason, George Stiny (1981) proposed adding description functions to the shape rules to generate relevant solutions. To explain the concept of description grammar, Stouffs (2015) provided examples of textual descriptions, such as strings, numbers of lists, functions, operators and parameters. According to Stouffs (2015), there are three types of descriptions: (1) reflections, (2) expressions and (3) design brief.

Chapter 2: Literature Review

Description Grammars as Reflection:

Based on the spatial vocabularies and the combinations of elements used in the design, this scheme was developed by Stiny (1981). For instance, (Li 2001) described the combinations of elements in his design as "six-rafter building, centrally divided, one-rafter beam in front and back, with five columns".

Description Grammars as Expressions:

Several authors have investigated description functions as they relate to spatial grammars applied to mechanical engineering to describe properties such as volume, cost, and manufacturing plan. Agarwal (1999), cited by (Stouffs 2015), introduced cost expressions or equations to evaluate a design's cost during its generation process.

Description Grammars as Design briefs (Programming Grammar):

This type of description is based on user data, which are values input by the user in the rule application or site data. This input parameter could be applied through a listing of "true" or "false," which constrains the parameter beyond a single value (Duarte 2005; Eloy and Duarte 2011). Jose Duarte (2001, 2005), while working on Siza's Malagueira housing programme guidelines and evaluation system, applied these descriptions in the "programming grammar". The purpose was to generate a symbolic description (the housing programme) using the user's input data. There are two types of descriptions in that study: variable and fixed (Figure 2.38, Figure 2.39 and Figure 2.40). According to Duarte (2005) in fixed descriptions, each feature has a fixed value, and the user cannot change them. In variable descriptions, the features comprise three categories.

- A. Constraints are contextual, typological and morphological features defined by the user and unmodified by the programmer.
 - Contextual features: site size, site context and object orientation.
 - Topological features: number of bedrooms and quality level.
 - Morphological features: house type and the number of floors.
- B. A user can evaluate the quality of a design based on its functions and aesthetic qualities.
 - Functions qualities: speciality and Topology, which describes the relationship between two spaces in terms of distance and communication.
 - Aesthetic qualities: size and proportion.
- C. Construction costs by specifying areas, materials, thickness of walls and number of floors (Heitor et al. 2004).

Customized house

Dwellers:

g19: Specifying dwellers information (user), and adding required bedrooms (programmer)

```

 $\alpha_3 \leftarrow \alpha_3, \alpha_3 = \text{custom}$ 
 $\alpha_4 \leftarrow \alpha_4 + < 1, (\text{name}_{n+1}, \text{age}_{n+1}, \text{gender}_{n+1}) >,$ 
     $\text{age}_i \in \{ '0-1', '2-5', '6-13', '14-17', '18-23', '23-65', '> 65' \},$ 
     $\text{gender} \in \{ \text{male}, \text{female} \}$ 
 $\alpha_5 \leftarrow \alpha_5 + < 1, [( \text{couple}, 0), ( \text{double}, 0), ( \text{single}, 1)] >$ 
 $\alpha_6 \leftarrow \alpha_6, q_{\text{level}} = \alpha_6$ 
 $\alpha_{13} \leftarrow \alpha_{13} + < \text{be}, \text{id}_{\text{be}}, (\text{name}_{n+1}), (\text{sleeping}), (\text{single}, 100), (q_{\text{level}}, 100), w_{\text{si}}, h_{\text{si}}, a_{\text{si}} >$ 
     $\text{id}_{\text{be}} = \max(\text{id}) + 1$ 
 $\sim \exists < ?\text{id}_{\text{be}}, ?\text{id}_{\text{r1}}, \text{on}, ?w > \in \alpha_{17}$ 
     $\Rightarrow \alpha_{14} \leftarrow \alpha_{14}, + \text{sleeping}(\text{id}_{\text{be}}, a_{\text{si}})$ 
     $\alpha_{15} \leftarrow \alpha_{15}, + < \text{available}, (0, -a_{\text{si}}, 0, -a_{\text{si}}), (0, 0, 0, 0), (0, -a_{\text{si}}, 0, -a_{\text{si}}), 0 >$ 
     $\alpha_{16} \leftarrow \alpha_{16}, + < \text{used}, (a_{\text{si}}, a_{\text{si}}, 0, a_{\text{si}}), (0, 0, 0, 0), (a_{\text{si}}, a_{\text{si}}, 0, a_{\text{si}}), -a_i / a_u + (a_i + a_{\text{si}} / a_u + a_{\text{si}}) >$ 
     $\alpha_{17} \leftarrow \alpha_{17}, + < [\text{id}_{\text{be}}, \text{id}_{\text{r1}}, \text{on}, 100] >$ 
 $\exists < ?\text{id}_{\text{be}}, ?\text{id}_{\text{r1}}, \text{on}, ?w >$ 
     $\Rightarrow \alpha_{14} \leftarrow \alpha_{14}, + f2(\text{id}_{\text{be}}, a_{\text{si}})$ 
     $\alpha_{15} \leftarrow \alpha_{15}, + < \text{available}, (0, 0, 0, 0), (0, -a_{\text{si}}, 0, -a_{\text{si}}), (0, -a_{\text{si}}, 0, -a_{\text{si}}), 0 >$ 
     $\alpha_{16} \leftarrow \alpha_{16}, + < \text{used}, (0, 0, 0, 0), (a_{\text{si}}, a_{\text{si}}, 0, a_{\text{si}}), (a_{\text{si}}, a_{\text{si}}, 0, a_{\text{si}}), -a_i / a_u + (a_i + a_{\text{si}} / a_u + a_{\text{si}}) >$ 
     $\alpha_{17} \leftarrow \alpha_{17}, + < [\text{id}_{\text{be}}, \text{id}_{\text{r2}}, \text{on}, 100] >$ 
 $\alpha_{24} \leftarrow \alpha_{24} + a_{\text{si}} \cdot \text{cm2}$ 
 $\beta_1 \leftarrow \beta_1, w_{\text{si}} = w(q_{\text{level}}, \text{si})$ 
 $\beta_2 \leftarrow \beta_2, h_{\text{si}} = h(q_{\text{level}}, \text{si})$ 
 $\beta_3 \leftarrow \beta_3, a_{\text{si}} = a(q_{\text{level}}, \text{si})$ 
 $\beta_6 \leftarrow \beta_6, \text{cm2} = \text{cost\_m2}(q_{\text{level}}, \text{covered})$ 

```

Figure 2.38: A sample of the programming grammar (Duarte 2001)

Chapter 2: Literature Review

Variable description (program description)				
Features	Groups of variables		α	Variables
Contexts	Lot		α_0	< w, l, h, a >
	Urban		α_1	<front, right, back, left>
	Solar orientation		α_2	<front, right, back, left>
Typology	Customization		α_3	< degree >
	Users		α_4	< number, [(name, gender, age, share),...] >
	Bedrooms		α_5	< number, [(couple, number), (double, number), (single, number)] >
	House quality		α_6	< initial quality, current quality >
Morphology	Yard location		α_7	< yard >
	Floors		α_8	< floors >
	Balconies		α_9	< balconies >
Spatiality	Capacity	Minimum obligatory spaces	α_{10}	< [use, number, ((articulation, number)...)]... >
		Initial obligatory spaces	α_{11}	< [use, articulation, weight],... >
		Current optional spaces	α_{12}	< [use, articulation, weight],... >
		Current spaces	α_{13}	< [name, id, (users, functions, (capacity, weight), (articulation, weight), (spaciousness, weight), (insertion point, rotations, width, length, height, area)],... >
		Zones	α_{14}	< [use,rooms, area],... >
	Spaciousness	Areas	α_{15}	< available, (max interior gross, min exterior gross, 1 st Floor gross), (max interior gross, min exterior gross, 2 nd Floor gross), (max interior gross, min exterior gross, house gross), useful/gross>
			α_{16}	< used, (inhabitable, interior useful, exterior useful, 1 st Floor useful), (inhabitable, interior useful, exterior useful, 2 nd Floor useful), (inhabitable, interior useful, exterior useful, house useful), inhabitable/useful >
Topology	Adjacency graph		α_{17}	< [(room1, room2, relation, weight)] ... >
Building elements	Windows		α_{18}	< [window, (room 1, room 2), (insertion point, depth, width, height, area)],... >
	Doors		α_{19}	< [door, (room 1, room 2), (insertion point, depth, width, height, area)],... >
	Walls		α_{20}	< [wall, (room 1, room 2), (insertion point, thickness, width, height, area)],... >
	Pavements		α_{21}	< [pavement, floor, (insertion point, width, length, thickness, area)],... >
Aesthetics	Proportion		α_{22}	< [proportion1, weight],...>
Quality			α_{23}	< [function, weight], [spatiality, weight], [capacity, weight], [articulation, weight], [spaciousness, weight], [topology, weight], [aesthetics, weight] >
Cost	Cost		α_{24}	c
History	Rule		α_{25}	< r1, r2,..., rm >

Fixed description				
Spaces dimensions	width	β_1	tables	width (space, quality)
	height	β_2	tables	height (space, quality)
	area	β_3	tables	area (space, quality)
Sectional dimensions	Pavement thickness	β_4		thickness (pavement)
	Floor height	β_5		height (floor)
Cost		β_6	table	unit_cost (element, material)

Figure 2.39: An example of a housing program with variable and fixed descriptions (Duarte 2001)

Chapter 2: Literature Review

Feature	Feature	α	Feature	Values
Morphology	Lot	α_0	Width	8 m ²
			Length	12 m ²
			Area	96 m ²
	Urban	α_1		Houses on three sides (default), house on one side, house at the back, house on the side and back
	Solar orientation	α_2		N, NE, E, SE, S, SW, W, NW
Typology	Customization	α_3		Custom, type (default)
	Dwellers	α_4	Number	1, 2, 3, 4, 5, 6, 7, 8, 9
			Name	User prompted Blank (default)
			Gender	Male Female Blank (default)
			Age	0-1, 2-5, 6-13, 14-17, 18-23 23-65, > 65, Blank (default)
		Share	Room Bed Blank (default)	
	Bedrooms	α_5	Number	1, 2, 3, 4, 5
Quality*	α_6	Initial	Minimum (default), medium, maximum (high)	
		Current	Minimum (default), medium, maximum (high)	
Morphology		α_7	Yard	Front, back
		α_8	Floors	1, 2
		α_9	Balconies	True, False
Spatiality	Capacity (dwelling)	α_{10}	Minimum	List of spaces' IDs
			Initial obligatory	
			Optional	
			Current	
			Zones	
	Spaciousness (dwelling)	α_{15}	Available	See Tables 7.8-7.10
			Used	m ²
	Name			Kitchen, laundry, pantry, living, closet, step-in-closet, stairs, patio, bedroom, bathroom, circulation, corridor, studio, balcony (terrace)
	Space ID			Random number
	Functions			See table 7.7
	Capacity (spaces)			1, 2, 3, 4, 5, 6, 7, 8, 9
Articulation (spaces)			Included, delimited, isolated	
Spaciousness (spaces)			See Tables 7.18-30	
Topology		α_{17}	Relation	Away, close, adjacent, window, door, passage, merged, any (default)
Aesthetics		α_{23}	Proportion	1:1, 1:√2, 1:2, 2:3, 3:4, 5:6
Quality		α_{22}	Weights	0, 5, 10, 15, ..., 100
Cost		α_{24}	Construction	USD \$ / m ²
History		α_{25}	Sequence of rules	Sequence of rule numbers

Figure 2.40: A sample Values associated with housing programs (Duarte 2001)

2.8.1.3. Discursive Grammars

A framework was developed by Jose Pinto Duarte (2001) to manipulate shapes, their descriptions and semantics to optimise a solution known as the deterministic process. There are two scales within the framework: at a micro-scale, choosing a rule for each step of design generation; at a macro-scale, the rules determine the optimum design that is close to the brief and appropriate for the context (Duarte 2001). Duarte (2001), in his PhD dissertation, applied discursive grammar to Alvaro Siza's Portuguese Housing Programme Guidelines at Malagueira.

Chapter 2: Literature Review

Through the use of programming grammar, he created a framework and an interactive computer system to transfer user requirements into a design brief. This grammar takes a variable of dimensions such as context, typology, morphology, space capacity and fixed parameters, including the height and width of the floor. A computer process then translates the brief using designing grammar into a set of solutions (Figure 2.41), (Duarte 2005).

The image shows a complex software interface with multiple panels. The left panel includes sections for Context (Urban: 'houses on both sides and back', Orientation: 'southwest'), Typology (Custom/Type selection, User profiles for John, Mary, David, and room requirements for Bedrooms, Users, Quality), Morphology (Yard: 'Front', Floors: '2', Balconies: 'yes'), and Capacity (dwelling and spaces) with various sliders and dropdowns. The right panel includes Topology (Rooms table with Kitchen, Laundry, and merged entries), Aesthetics (Proportion: '1:1', Weight: '30'), Quality (Current: '2.5 (Medium)'), Weights (Function, Spatiality, Capacity sliders), Articulation (sliders for 30 and 30), Spaciousness (sliders for 30 and 30), Topology (sliders for 40), Aesthetics (sliders for 55), and Cost (Space Type: 'Covered', Cost / m2: '\$ 350.00', Current cost: '\$37,500.00'). At the bottom, there are buttons for 'Done', 'Save', 'Load' under 'Program' and 'Derive', 'Save', 'Load' under 'Solution'.

Figure 2.41: An example of the interface (MALAG) that translates user requirements into a design brief (Duarte 2001)

2.8.1.4. Application of Shape Grammars in Architecture

Several studies implemented shape grammars in the architecture field. The following exemplifies this implementation. In "A Pattern Language," Christopher Alexander (1977) examined the patterns of good design practices to gain insight into what makes architecture so dynamic and beautiful. In pattern languages, the relationships (the syntax) between different patterns (vocabularies) are defined in a hierarchical order (Alexander 1977). Downing and Flemming (1981) presented the measured drawings of seven bungalows. This paper discusses the space-organisation conventions in these bungalows and establishes links

Chapter 2: Literature Review

with other house types in the popular tradition. Using the schemata of a parametric shape grammar, they explained differences between bungalows as different geometric realisations of standard conventions (Downing and Flemming 1981).

(Flemming 1987), uncovered the specific shape grammars that produce Queen Anne houses. Separate grammars were presented to generate and articulate plans in three dimensions. The study emphasised geometric features and the overall design and explained how parts and features relate. (Chiou and Krishnamurti 1995), proved that shape grammars can visually illustrate and explain the style of traditional Taiwanese vernacular housing. (Cagdas 1996), proposed parametric shape grammars for generating plans of traditional Turkish houses. (Wang and Duarte 2001), presented a framework for creating and fabricating architectural massing designs. The framework consists of two components: a computer programme that translates shape grammars into design concepts and technology that produces physical models based on the generated designs.

(Colakoglu 2005), applied an informal shape grammar to generate new Hayat-style house designs. The grammar creates house types in three steps: (1) primitive Hayat house generation, (2) sub-house generation and (3) house variations. Andaroodi et al. (2006) developed methods to extract the attributes of the spatial organisation of caravanserais from a selected corpus of cultural heritage relics using a shape grammars schema. (Eilouti and Al-Jokhadar 2007), demonstrated how to develop a Rule-Based Design (RBD) system using information inferred from case studies. The paper proposed a five-phase system of rules to help restructure and represent the unstructured information embedded in precedents through reproductive and recursive rules. This proposed method can regenerate existing precedents and generate new designs based on the same stylistic prototypes. Said and Embi (2008) presented a parametric shape grammars of traditional Malay houses (TMH) built during the 20th century. Based on simple geometric representations of the houses, TMH grammar consists of rules for generating its structure and form (Said and Embi 2008).

(Torus 2012), demonstrated how to generate repetitive elements (in Correa's case, houses) using such rules. The author used the computing approach to generate the analytical shape grammars studies based on the local vernacular to enable the architect to design adapted and efficient houses. (Eilouti 2012), examined the applicability of a nine-square grid, examining two precedents from Sinan's and Palladio's work. To compare their vocabulary elements, proportions and compositions, two designated designs were visually, morphologically and mathematically analysed. Further, they were mapped to grid units based on their architectural

assignments and their transformations into design configurations. The paper resulted from a report and discussed the similarities and differences between the two designs.

2.8.2. Non-Manifold Topology (NMT)

(NMT) involves a mixture of vertices, edges, surfaces and volume. An NMT representation can combine these elements consistently, whereas the traditional boundary representation cannot represent, for instance, a vertex, edge and a solid in one representation (Jabi 2016). NMT, as a mathematical concept, refers to cell complexes that are subsets of euclidean space (Masuda 1993).

Aish and Pratap (2013), described the distinction between the manifold and non-manifold topology: manifold bodies are 3D objects with boundaries that separate enclosed solids from external voids. The faces of the boundary comprise (interior) solid material on one side and (exterior) void on the other (Figure 2.42). Aish elaborates further by saying, "In practical terms, a manifold body without internal voids can be machined out of a single block of material." However, the non-manifold body has a boundary of composed faces, but it separates the enclosed solid from the external void. "Faces are either external [separating the interior (enclosed space) from the exterior (void)] or internal [separating one enclosed space (or cell) from another]." (Aish et al. 2018, p. 319). Furthermore, non-manifold solids can have edges that meet more than two faces. According to Aish and Pratap (2013), one way to construct non-manifold bodies involves using regular and non-regular Boolean operations (Figure 2.43). Typically, when performing Boolean operations, inputs within the resulting body have their external faces removed. However, when performing non-regular Boolean operations, inputs within the resulting body have their external faces reserved.

Chapter 2: Literature Review

	union	intersection	difference	impose	imprint	slice
regular inputs						
regular operations	 1 body			N/A	 only imprint edges on external faces, no cells created	 multiple bodies
non-regular operations	 1 body with multiple cells	N/A	N/A		 imprint external faces of B within A, creating cells	

Figure 2.42: The result of regular and non-regular Boolean operation with manifold input (Aish and Pratap 2013).

	union	intersection	difference	impose	imprint	slice
non-regular inputs						
regular operations	 Some laminar faces created			N/A	 only imprint edges on external faces, no new cells created	 multiple bodies each with cells
non-regular operations	 1 body with multiple cells	N/A	N/A	 faces of the blank (A) in the tool (B) are removed	 imprint external faces of B within A, creating cells	

Figure 2.43: The result of regular and non-regular Boolean operation with non-manifold input (Aish and Pratap 2013)

In 2018, Jabi and his Topologic team described the difference between manifold and non-manifold geometry from a computational architectural point of view. Building information modelling (BIM), computer-aided design (CAD) and parametric visual data flow programming (VDFP) software typically rely on low-level geometric engines (kernels) and software

Chapter 2: Literature Review

development kits (SDK). These geometrical kernels are classified as manifold or non-manifold (Chatzivasileiadi et al. 2018b). The manifold kernels are three-dimensional entities formed by connecting boundary elements separating the outside space from the interior. An entity with a boundary (manifold), such as a curve or surface, can be unfolded into a continuous flat plane (also known as a 2-manifold). Recent proposals have focused on modelling architectural space using non-manifold topologies (Jabi et al. 2017). Lines, surfaces and voids can be shaped using cells, and the collection of cells is referred to as a cell complex or a cluster. This approach resulted in the Topologic toolkit, which supports simple binary operations on this structure.

2.8.2.1. Topologic Toolkit

Topologic⁽²⁾ is a 3D modelling software library developed by (Jabi et al. 2018), that enhances the representation of space in 3D parametric and generative modelling environments, such as Dynamo⁽³⁾, Grasshopper⁽⁴⁾ and Sverchok⁽⁵⁾. Topologic is based on the concept of non-manifold topology. Topologic's classes include Vertex, Edge, Wire, Face, Shell, Cell, CellComplex, Cluster, Topology, Graph, Aperture, Content and Context (Figure 2.44). A Vertex is a point in 3D space with X, Y and Z coordinates. An Edge connects a start Vertex to an end Vertex. A Wire connects several Edges. A Face comprises a set of closed Wires. A Shell is a set of connected Faces that share Edges. A Cell is made from a closed Shell. A CellComplex is a set of connected Cells that share Faces. A Cluster is a grouping of topologies of any dimensionality. A Graph is a special data structure derived from Topologies. An Aperture is a special type of Face hosted by another Face. Any Topology can have additional Topologies added to its Contents. In turn, these Content Topologies will have a pointer back to their Context Topologies. This development is similar to a parent/child relationship. In addition, any Topology can have a Dictionary that can hold any number of arbitrary key-attribute pairs.

(2) <https://topologic.app> (accessed on 20/03/2019)

(3) <https://dynamobim.org> (accessed on 23/12/2019)

(4) <https://www.grasshopper3d.com> (accessed on 23/12/2018)

(5) <https://github.com/nortikin/sverchok> ((accessed on 03/10/2021)

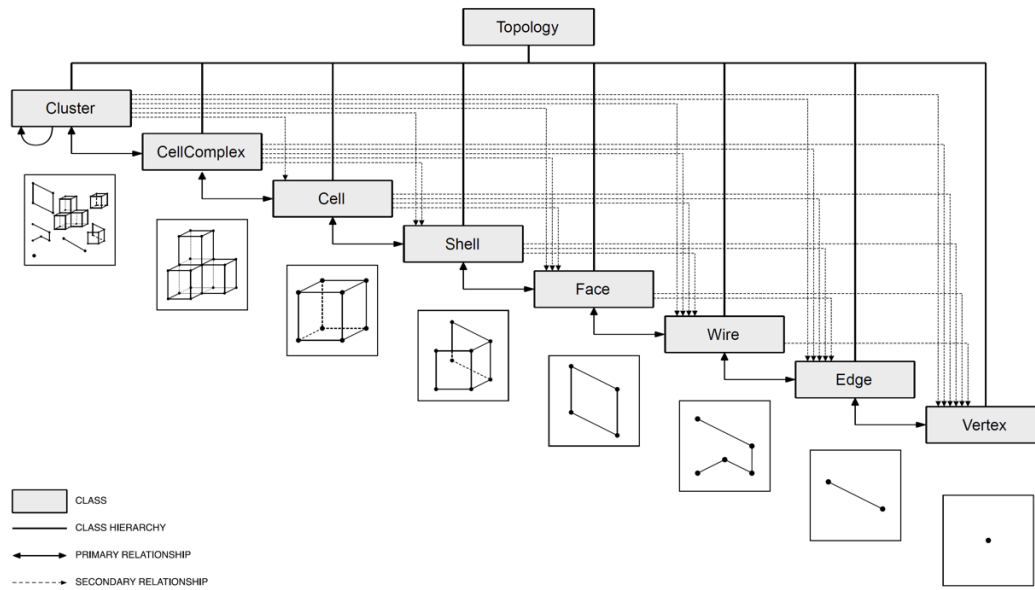

Figure 2.44: Topologic Core Class Hierarchy

According to (Aish et al. 2018), three types of topological relationships can be built and queried using Topologic (Figure 2.45):

Hierarchical relationships: The relationship between topological entities of different dimensions. In other words, whenever a higher dimensional topology construct comprises a collection of lower dimensional topologies, these relationships are created.

Lateral relationships: These appear within a topological construct when its constituents share a topology of lower dimensionality.

Connectivity: A path from two topologies can be queried.

Moreover, Topologic has the opportunity to idealise the architectural representation. Aish et al. (2018) described the four architectural idealised models of Topologic:

Energy Analysis: The partitioning and adjacency of thermal zones and spaces can be represented by a CellComplex.

Structural Analysis: Clusters can represent a mixed-dimensional model. Faces correspond to the structural slabs, blade columns and shear walls, Edges correspond to structural columns, and Cells correspond to the building cores.

Digital Fabrication Analysis: The CellComplex represents the design envelope, in which topology influences the shape and interface of the deposited material.

Circulation Analysis: CellComplexes can be represented as dual graphs that show the relationships between spaces.

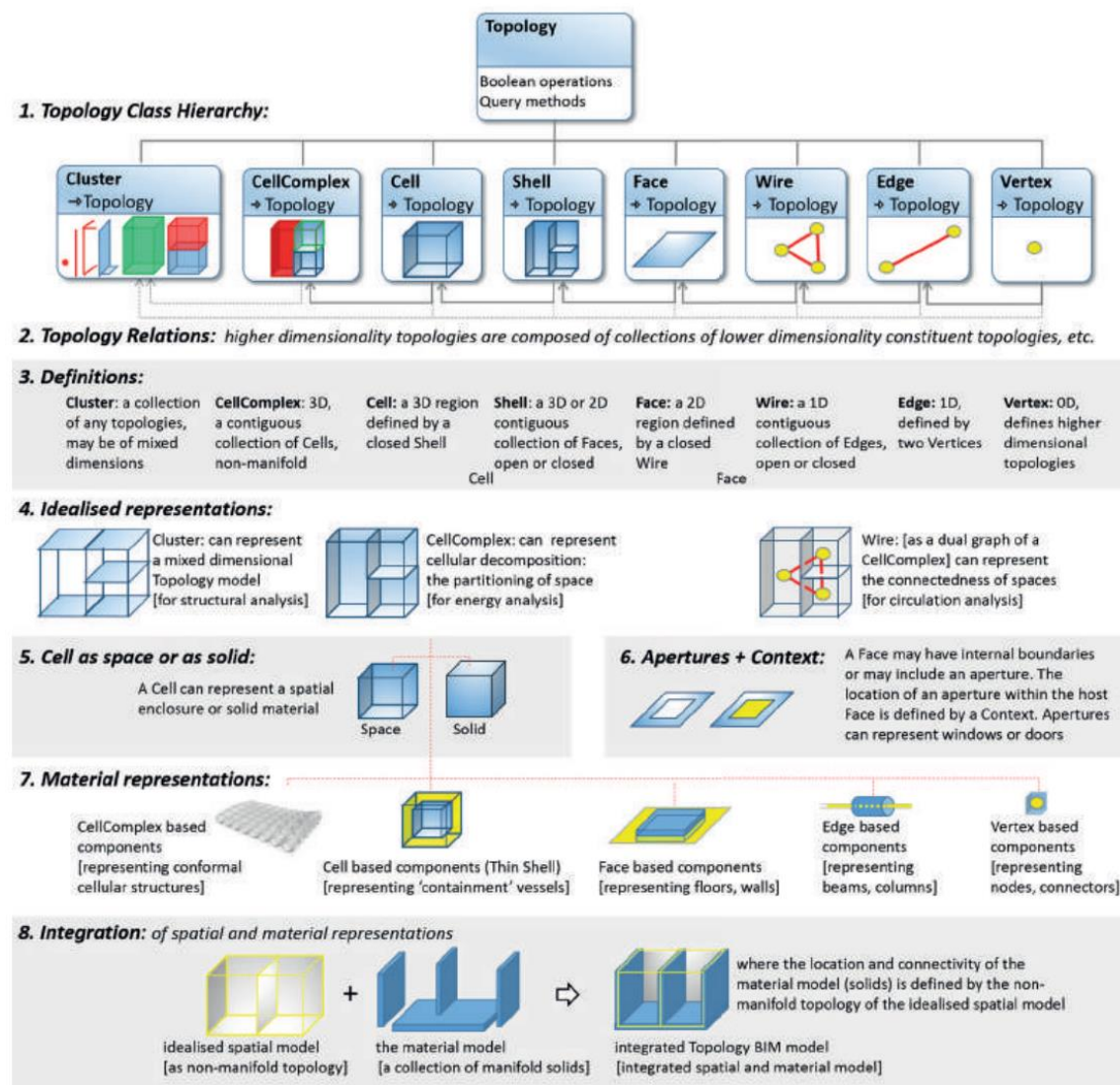

Figure 2.45: Eight key points of the Topologic application toolkit (Aish et al. 2018)

2.8.2.2. Application of Non-Manifold Topology in Architecture

Several research papers have discussed the advantages of using non-manifold modelling over the manifold equivalent (Chang and Woodbury 1997; Lee et al. 2009; Nguyen 2011; Aish and Pratap 2013; Jabi and Aish 2018). NMT can divide the enclosed space into separate zones and spaces using zero-thickness internal surfaces, allowing for a lightweight representation of the building. Due to the topological consistency of NMT, a user can query the spatial spaces and surfaces regarding their topological data and then conduct various analyses.

Jabi (2015); Jabi (2016), discovered the potential of non-manifold topology in the early design stages. His research aimed to investigate a new method for 3D modelling, non-manifold topology (NMT), with the potential to be compatible with early design stages and input

Chapter 2: Literature Review

requirements for building performance simulation (BPS). Jabi proposed an approach where BPS can occur without simplifying polyhedral models produced by BIM software. The research methods consisted of, firstly, studying appropriate software platforms and libraries; secondly, determining design criteria from the literature review; thirdly, building and testing the software prototype; and finally, analysing the case study results. According to the findings, non-manifold topology holds significant potential in representing building surfaces and spaces in a manner that proves compatible with the input requirements of building performance simulation engines. In conjunction with non-manifold topology and a versatile 3D software environment, architects can take a more topological approach to design and investigate the performance of buildings in the early stages of development using simple 3D massing models that maintain design creativity and flexibility.

Chatzivasileiadi et al. (2018a), presented four approaches to the energy modelling of a building with relatively complex geometry and curved surfaces. These four approaches formed a visual data flow programming application (VDFP) using NMT and the model exported to OpenStudio. Second, OpenStudio uses a non-manifold topology (NMT) system based on an open-source geometry library. Third, OpenStudio uses the SketchUp 3D modelling tool and the Design-Builder graphical user interface. These research results demonstrate that the VDFP/NMT pathway could handle complex geometry efficiently and deliver reliable results while benefiting from NMT's advantages. The paper concluded that NMT provided a better spatial representation of a building and an idealisation of curved geometry that proved more suitable for energy simulations.

Jabi et al. (2018), demonstrated the potential of Topologic in preparation for structural analysis. The topologic structure allows users to build structural models and apply structural loads rapidly. Using a list of vertices and indices, Jabi intended to construct a topological shape and apply structural loads. The method used to create a model involved an array of vertices and a list of vertex indexes, defining a list of locator points and applying varied structural loads to these sub-shapes. Consequently, the topological model proved highly compatible with the requirements of structural analysis software.

The (NMT) is a helpful tool for understanding, analysing, and evaluating architectural space and the relationship between space's connectivity and architectural elements. Moreover, NMT can model lightweight representation of the building, which helps the architects take a more topological approach to design and investigate the performance of buildings in the early stages. This approach will enable them to make informed design decisions in the early stages before the BIM models are produced.

2.8.3. Graph Theory

Graph theory is a branch of mathematics used to model relations between objects. A simple graph (G) consists of a set of points called vertices ($V(G)$), and the lines that join pairs of points are called edges ($E(G)$). The degree of a vertex in a graph comprises the number of edges connected to it. Vertices connected by an edge are called adjacent vertices. Similarly, edges that share a common vertex are called adjacent edges. "Digraphs" are graphs in which the edges have a predetermined orientation. Any two graphs that have a one-to-one correspondence between the number of vertices, the number of edges and the degree of vertices are called isomorphic graphs.

In 1735, Leonhard Euler published an analysis of an old puzzle regarding crossing seven bridges that span a river between two central landmasses (no bridge can be crossed twice). Topology and graph theory trace back to Euler's proof that no such path exists and his generalisation of the problem to all possible networks. Communication networks, power transmission systems, transportation networks and computer architectures have all undergone analysis and been designed using graph theory since the mid-20th century (Britannica 2010).

Graphs can represent many types of relationships and processes, including those in physical, biological, social and information systems. Recent studies have applied graph theory to several fields of architecture in the context of planning (Lakshmi 2019).

2.8.3.1. Application of Graph Theory in Architecture

Ruch et al. (1978), proposed an interactive programming approach for the layout of architectural spaces (Ruch et al. 1978). The paper suggested graphs, bubble diagrams and schematic plans as three hierarchical levels of abstraction. Computer-designer interfaces generate alternative designs at each level.

Franz et al. (2005), outlined several regions of common interest between graph applications in architecture and cognitive science beyond the purely formal. These commonalities promise mutual benefit from better awareness and knowledge of the concepts of each other. Below is an overview of the different graph models (Figure 2.46).

Chapter 2: Literature Review

graph model	nodes	edges	pictogram	
occupancy grids	xy-intervalls with obstacle probability	predefined, non-directional		
place graph	local position information at places	local navigation rules		
view graph	local position information at place transitions	local navigation rules, directional		
access graph	spaces	connectivity		
axial map	lines of sight	intersections		
isovist field	viewshed polygon	mutual visibility		
visibility graph	xy-intervalls	mutual visibility		

○ = node ◁ = directional edge ◄ = non-directional edge

Figure 2.46: Overview on the different graph models (Franz et al. 2005).

Shekhawat et al. (2019), aimed to describe an algorithm that generates floor plans corresponding to any given planar graph. A user-friendly tool sought to generate initial layouts of a given graph, which architects and designers could modify. The work only considered adjacency constraints, whereas a floor plan with architectural significance must consider at least dimensional constraints. A year later, (Upasani et al. 2020), proposed a methodology for automatically creating rectangular floor plans (RFPs) that addressed dimensional limitations and adjacency relations. The approach started with rectangular arrays of 2D matrices with dimensional constraints, followed by developing St-graphs to extract adjacency relationships, and finally by modelling them as flow networks, with each edge carrying non-zero, non-negative flow. The problem ultimately found a solution using linear optimisation techniques.

Using structured architectural datasets, (Lu et al. 2021), presented a new synthetic workflow for generating room relation graphs. Vectorised floor plans formed part of the paper method and were parsed to create their intended organisational graph. Using floor plans from the popular CubiCasa5K dataset as inputs, this dataset gathered graph representations generated by the proposed algorithms known as CubiGraph5K. The paper aimed to develop a matching dataset to train neural networks in future research and perform enhanced floor plan parsing, analysis and generation.

2.9. Artificial Intelligence

Machines understand "learning" as the ability to process the complexity of the presented options and then develop an "intuition" to solve the problem at hand. John McCarthy coined the concept of AI in 1956, describing it as "using the human brain as a model for machine logic". Rather than designing a deterministic model based on a set of variables and rules, AI uses information from data transmitted by the user to create intermediary parameters. The machine becomes capable of generating solutions once the "learning phase" has been completed, by answering a set of predefined parameters and simulating the statistical distribution of the data presented to it. AI stands at the core of the paradigm shift brought about by this concept (Chaillou 2019).

Historically, Ada Lovelace is credited with the invention of artificial intelligence. Lovelace wrote a programme that ran on a computer before computers were invented. In 1842, Lovelace stated, "The analytical engine has no pretensions to originate anything. It can do whatever we know how to order it to perform" (De Roure and Willcox 2017, p. 195). This was the beginning of the AI discussion. Alan Turing published his paper presenting the Turing test in 1950 (Turing A. M 1950). During the Second World War, Alan Turing successfully cracked the German code known as the Ultra Code. A milestone was reached after Ady Lovelace's comment in 1842 when Turing published his paper in 1950. During the 1960s, Marvin Minsky wrote a paper titled "Steps Toward Artificial Intelligence" that marked the beginning of the modern era (Minsky 1961).

Some theorists saw AI's potential for architectural design and predicted its penetration in the field. In URBAN II, Negroponte and his team had already begun working on a "machine assistant". Through URBAN V, users could design rooms based on their proximity and light conditions (Chaillou 2019).

Nowadays, AI and ML have become popular and often hyped terms. Unspecialised individuals often use both terms interchangeably when discussing intelligent software or systems. However, AI and ML do not represent the same thing, even though both are based on statistics and mathematics. It has become necessary to examine two crucial differences between AI and ML to determine the differences between them. It is possible to accomplish this by understanding the two definitions. John McCarthy defined AI as "the science and engineering of making intelligent machines". However, in 1959 Arthur Samuel defined ML as the process by which computers can learn automatically by observing data rather than being explicitly programmed (Samuel 1959).

2.9.1. Machine Learning

Machine learning represents a way for computers to learn how to simulate human learning. ML functions by automating the process of building analytical models and adapting to new scenarios independently (Wang et al. 2009). The simplest ML definition is "learning from data" (Geron 2019). Tom Mitchell defined machine learning as more oriented to his field (engineering): "A computer programme is said to learn from experience E with respect to task T and performance measure P, if its performance on T, as measured by P, improves with experience E" (Mitchell 1997, p. 2).

Machine learning has great potential. It is recognised that ML can simplify a code to perform better than hand training or can write a long code of rules. With the help of ML, it becomes possible to find a solution otherwise unobtainable using a conventional approach (Figure 2.47).

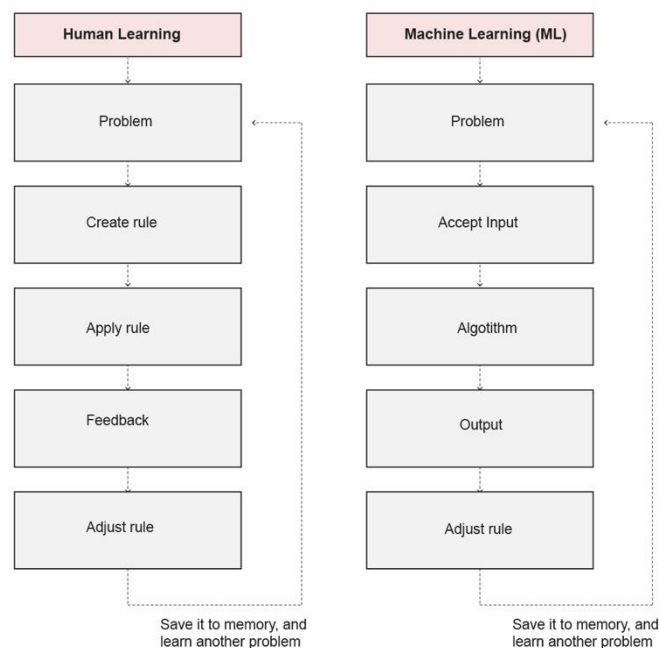

Figure 2.47: Human learning vs. Machine learning

Additionally, ML can handle complex problems and a large amount of data. When using the traditional approach to solve a problem, must first formulate the problem and how it appears, then write the rules and algorithms, test the model and repeat the steps until achieving a satisfactory result. On the other hand, a ML approach learns the problem based on the data provided to the algorithm and then tests the model (Géron 2017).

Chapter 2: Literature Review

Machine learning algorithms can be classified according to the amount and type of supervision provided. There are four major categories of ML: unsupervised, supervised, semi-supervised and reinforcement learning (Géron 2017; Rafique and Velasco 2018) (Figure 2.48).

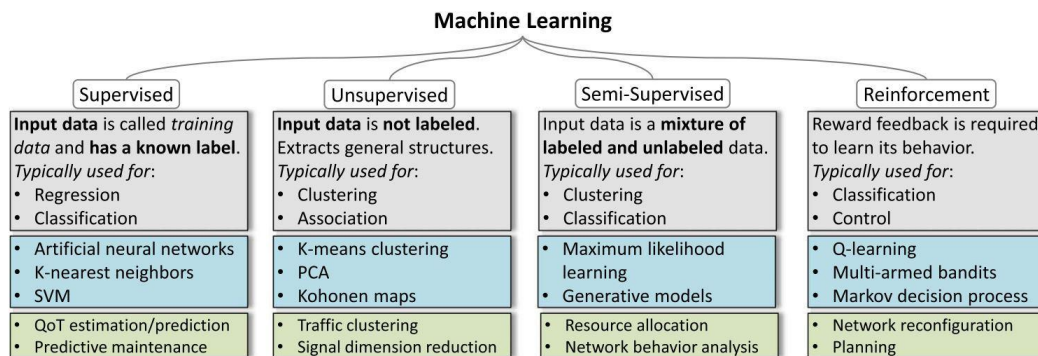

Figure 2.48: ML families. An ML approach is characterized by a square box in the first column; an algorithm example in the second column; and an example of an application which uses the approach in the third column (Rafique and Velasco 2018)

2.9.1.1. Supervised Machine Learning Algorithm

Supervised ML involves feeding the algorithm the training data that includes the desired solution, called labels. An example of supervised learning is classification trained on data labelled with their classes to determine how to classify new information. Regression is another task that involves predicting a target, such as the price of land, based on a set of features (the area of the land, the location and so on). Classification predicts discrete targets while regression predicts continuous targets. Classification and regression are distinct types of machine learning tasks (Geron 2019). According to "hands-on machine learning" with Scikit learn, the most important supervised learning algorithms are: Linear Regression, Logistic Regression, Support Vector Machines (SVMs), Decision Trees and Random Forests, Artificial Neural Network (ANN), and K-Nearest Neighbours (KNN). However, this literature review section focuses on the different types of neural networks in deep learning, especially in the classification task.

2.9.1.2. Unsupervised Machine Learning Algorithm

In unsupervised learning algorithms, the training data is not labelled meaning the algorithm learns without a teacher. According to hands-on machine learning with Scikit learn, the most widely used unsupervised learning algorithm is clustering, such as K-Means, Hierarchical Cluster Analysis (HCA), Expectation Maximisation and Gaussian Mixture (GM). Visualisation and dimensionality reduction include Principal Component Analysis (PCA.), Kernel PCA, Locally Linear Embedding (LLE) and t-distributed Stochastic Neighbour Embedding (t-SNE).

Chapter 2: Literature Review

Unsupervised algorithms also include visualisation algorithms, which present data in 2D and 3D outputs, which can then be plotted. The visualisation algorithm helps clarify the data organisation and find unsuspected patterns through the 2D or 3D output map (Geron 2019). A related task is a dimensional reduction, which simplifies the data without losing match information by merging two features in a process known as feature extraction.

2.9.1.3. Semi-supervised Machine Learning Algorithm

The semi-supervised learning (SSL) technique is a type of ML. This method falls between supervised and unsupervised learning, as the dataset is partially labelled. SSL aims to overcome the limitations of supervised and unsupervised learning. The supervised learning process requires a large amount of labelled training data to classify the test data, which is time-consuming and costly. While unsupervised learning requires no labelled data, it clusters the data by clustering or maximum likelihood using similarity between the data points. This approach shows its limitations because it cannot cluster unknown data accurately. SSL has been proposed by the research community as a way to overcome these issues, which can identify unknown or test data with a small amount of training data. SSL uses a few labelled patterns for training and treats the rest for testing. Semi-supervised learning is divided into semi-supervised classification and semi-supervised clustering (Reddy et al. 2018).

2.9.1.4. Reinforcement Learning

RL, as part of ML, involves optimising an agent's behaviour within an environment to maximise an award (Thombre 2018). RL agents learn to carry out sequences of actions that maximise their cumulative awards, similar to using treats to teach a pet to do tricks. By observing its environment and learning from its own actions, an RL agent learns how to perform the trick. Consequently, it is artificially intelligent in the sense that it trains itself. Therefore, RL agent also learns to avoid actions that do not reward them or give them negative rewards or "punishments" (Jabi et al. 2019).

2.9.2. Clustering Algorithm (Unsupervised)

Cluster analysis groups objects as observations or events based on the datum found in the information describing the objects or their relationships (Sharma et al. 2012). Clustering gathers a set of similar objects into the same group called a cluster. Cluster analysis is a ML task that uses a ML algorithm. The clustering task can be achieved by implementing diverse algorithms that differ in their concept and the process of deciding the output. Clustering plays an essential role in data analysis. Clustering algorithms prove useful in many problem domains

and have continued to develop in various areas because not all algorithms suit all application types (Dharmarajan and Velmurugan 2016).

2.9.2.1. Centroid Clustering Models

In the centroid model, the concept of similarity derives from the closest point to the centre of the clusters. Many algorithms use this clustering approach, such as K-Means, K-Medoids and K-Modes. These models require the user to input the desired number of clusters, which makes it essential to have prior knowledge of the dataset. Centroid clustering models need to run iteratively to find the optimal solution (Figure 2.49).

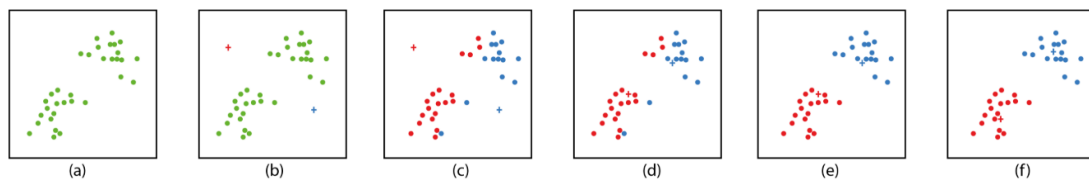

Figure 2.49: The centroid clustering algorithm processes

2.9.2.2. K-Means Cluster Algorithm

K-means is a prevalent ML approach for clustering (Hartigan.J.A and Wong M.A. 2001). K-means is a distance-based, unsupervised machine learning algorithm that uses an intrinsic relationship between data points (Stasiuk and Thomsen 2014). The initialisation steps of the k-means algorithm proceed as follows: (1) selecting the first division with K clusters; (2) generating a new division by assigning each point to its closest cluster centre; and (3) calculating new cluster centres (Jain and Dubes 1988). Step (4) reiterates steps (2) and (3) repeatedly until reaching a stable state, in which the data points no longer change between clusters, meaning centroids do not require any recalculation (Stasiuk and Thomsen 2014).

2.9.2.3. K-Modes Cluster Algorithm

A similar alternative to k-means is the k-modes clustering algorithm, which replaces the "means" of clusters with "modes". K-modes are an unsupervised learning option because there are no assumptions about the data. A crucial k-modes feature involves explicitly optimising a "matching" metric, which corresponds to the loss function (Chaturvedi et al. 2001).

2.9.2.4. Gaussian Mixture Models (GMM)

Gaussian mixture models (GMM) are an extension of the k-means algorithm model in which clusters are modelled with Gaussian distributions. GMM is used primarily for probability density estimation, also known as soft clustering (He et al. 2017). Furthermore, the concept

Chapter 2: Literature Review

of using GMM is to find clusters with similar properties, which means information has overlapped (Yambem and Nandakumar 2016). A GMM comprises numerous Gaussians, each identified by k . $\{1, \dots, K\}$, where K is the number of clusters. Each Gaussian K consists of the following parameters: μ mean, which defines its centre; Σ probability, which defines its width; and π , which defines the Gaussian function's size (Carrasco 2019). Moreover, for a Gaussian function, the mean value or vector defines where the distribution is located or centred. The variance value or covariance matrix defines the width of the distribution in the difference dimensions.

2.9.2.5. Applications of Clustering Machine Learning Approaches in Architecture

This section will focus on clustering algorithm applied to the field of architecture. Grouping the architecture and the architect's style has received much attention over the past decade. The first study of clustering and classifying architectural styles attempted to build a machine vision system for classifying windows according to architectural styles (Shalunts, Gayane, Yll Haxhimusa 2011). A year later, (Shalunts 2012) offered a similar digital approach based on clustering and utilising local features to classify building facades according to Gothic and Baroque styles. According to (Xu et al. 2014), most of the current architectural style classification algorithms focus on the effective extraction of distinctive local patches or patterns (Berg et al. 2007; Philbin et al. 2007). The last five years have seen a new development in architectural style classification using deep convolutional neural networks (DCNN). Obeso et al. (2016), aimed to use DCNN to classify Mexican historical buildings, while (Yoshimura et al. 2019), proposed to apply it during the classification of architectural design.

Glaser and Peng (2003a), examined the LiQuID tool, which clustered lighting simulation data. They aimed to reduce large complex sets of photographs by classifying them into representative prototypes. LiQuID and Light Sketch tools help architects create a quick design and decide on the building's light quality. However, these methods encounter numerous pitfalls. Firstly, the classification does not consider illuminance data. Secondly, the visualisation of clusters requires further development. Finally, the similarities between larger temporal units need to be addressed.

Chen et al. (2015a), conducted experiments examining the resulting population of alternate designs and providing insight into the relationship between architectural features and design performance. The experiments showed that it is possible to gain general knowledge by linking architectural features to design performance. Considerable ambiguity remains about this information because it is not easy to rely on the specific groups undergoing comparison.

Chapter 2: Literature Review

Moreover, it does not seem to have any architectural features, which, in turn, makes it complicated to conclude anything in terms of performance.

Lee and Lee (2016b), investigated the colour pattern difference between Eastern and Western cultures using a case study of Disneyland Paris and Tokyo Disneyland. The result indicated that the former used green and bluish colours while the latter featured more red and yellowish colours based on CIELAB colour space values. This paper encountered difficulties obtaining building images due to trees or visitors in the park obscuring the view. Therefore, the result can improve with higher resolution images.

2.9.3. Deep Learning Neural Network

A subfield of ML known as deep learning uses algorithms inspired by the brain's structure and function called artificial neural networks. Andrew Ng described deep learning in terms of traditional artificial neural networks. His 2013 talk entitled "Deep Learning, Self-Taught Learning, and Unsupervised Feature Learning"⁶ described deep learning as using brain simulations. Such an approach can make learning algorithms more efficient and easier to use and enable breakthroughs in machine learning and artificial intelligence. According to (Schmidhuber 2015), deep learning simplifies and quickens the process when large amounts of data require collection, analysis and interpretation.

There are many types of deep learning neural networks, such as Artificial Neural Networks (ANN), Convolutional Neural Networks (CNNs), Long Short-Term Memory Networks (LSTMs), Recurrent Neural Networks (RNNs), Generative Adversarial Networks (GANs), Radial Basis Function Networks (RBFNs), Multi-layer Perceptrons (MLPs), Self-Organising Maps (SOMs), Deep Belief Networks (DBNs), Restricted Boltzmann Machines (RBMs) and Graph Neural Network (GNN). However, this section will focus on common deep learning types in architectural design.

1. Artificial Neural networks (ANNs) are also called Feed-Forward Neural Networks. ANN proves beneficial because it can sort information on the entire network and work with incomplete knowledge. However, the drawback of ANN is its hardware dependency and unexplained behaviour. A multi-layer fully connected artificial neural network (ANN) looks like the one in (Figure 2.50). Input, hidden, and output layers are all included. In each layer, every node is connected to every other node. Adding hidden layers deepens the network.

⁶ <https://www.youtube.com/watch?v=pfFyZY1RPZU>

Chapter 2: Literature Review

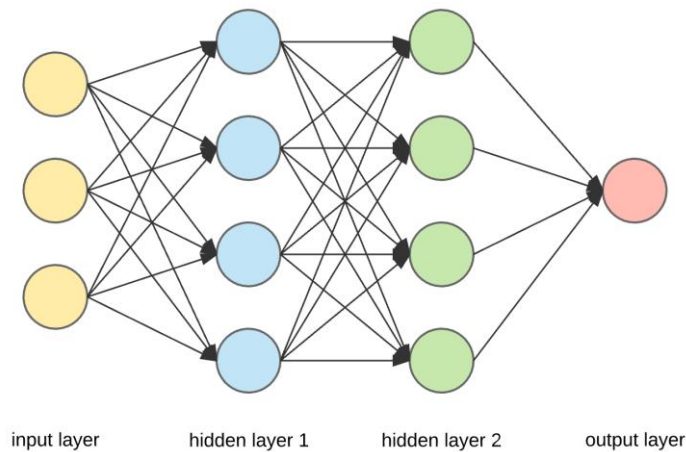

Figure 2.50: An example of ANN structure (Source: <https://towardsdatascience.com/applied-deep-learning-part-1-artificial-neural-networks-d7834f67a4f6>, Accessed: 10 August 2022).

2. Convolutional Neural Networks (CNNs) are a deep learning algorithm that can take an input image and assign weights and biases (learnable weights) to various aspects/objects and differentiate them. The CNN structure contains one or more convolutional layers that can be entirely connected or pooled. The advantage of CNN is that it can accurately solve image recognition problems and automatically detect crucial features without human supervision. However, the drawback of this algorithm is that it does not encode the position, and the orientation of the object and the input data are not spatially invariant.

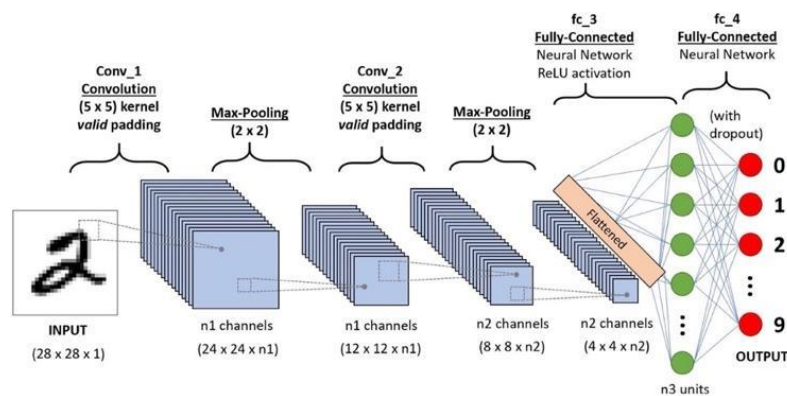

Figure 2.51: An example of CNNs structure (Source <https://towardsdatascience.com/a-comprehensive-guide-to-convolutional-neural-networks-the-eli5-way-3bd2b1164a53>, Accessed: 10 August 2022).

3. Recurrent Neural Network (RNNs) are an artificial neural network commonly used in speech recognition and natural language processing. RNN can recognise the sequential characteristics of data and predict the likely outcome based on patterns. One or more feedback loops connect neurons in this model. Input circles are intermittent cycles that occur after a period of time or succession (Figure 2.52).

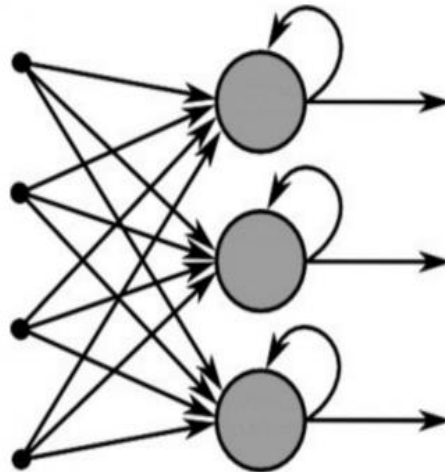

Figure 2.52: An example of RNN structure (Source <https://builtin.com/data-science/recurrent-neural-networks-and- lstm> , Accessed: 10 August 2022).

4. Generative Adversarial Networks (GANs) use two neural networks in competition to enhance their predictive accuracy. GANs consist of two neural networks, the generator and the discriminator (Figure 2.53). Combined neural networks create the generator and discriminator. Generators generate outputs that can be mistaken for real data. In order to identify artificially created outputs, the discriminator distinguishes between them (Pan et al. 2019).

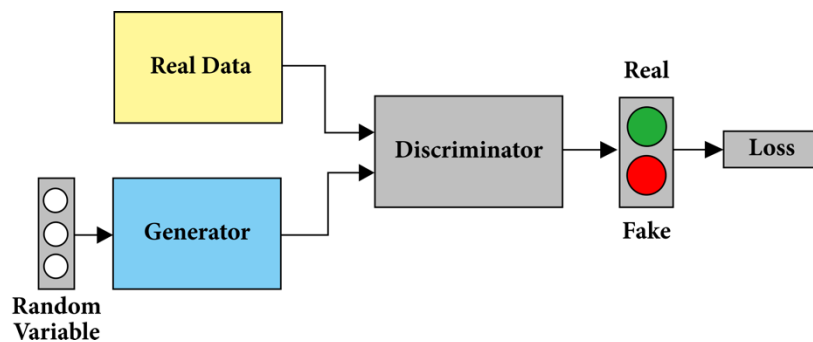

Figure 2.53: An examples of GANs structure (Source:<https://www.hindawi.com/journals/scn/2018/9203076/fig2/> , Accessed: 14 August 2022).

5. Graph Neural Networks (GNNs) combine feature information with graph structure and can learn better representations of graphs using feature propagation and aggregation. In recent years, GNN has become one of the most used tools for graph analysis due to its high interpretability and convincing performance (Figure 2.54). There will be a detailed discussion of GNNs and their different structures in Section 2.9.4.

Chapter 2: Literature Review

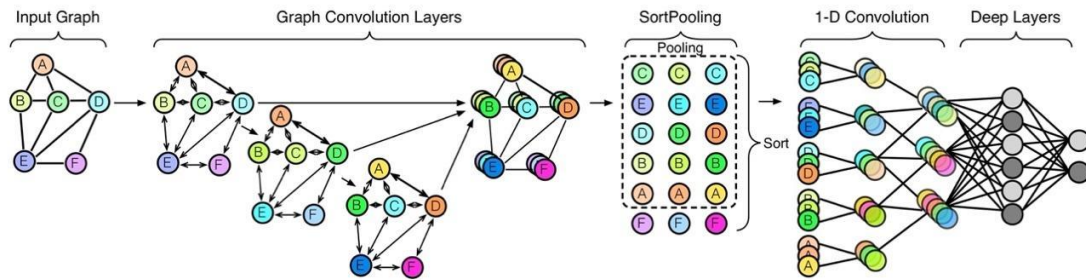

Figure 2.54: The general structure of DGCNN (author after Zhang et al. 2018).

2.9.3.1. The Application of Deep Neural Network in Architecture

In 2016, Silvestre et al. published a paper to assess whether an AI system using deep convolutional neural networks (ConvNet) can "imagine" architecture (Silvestre et al. 2016). Multiple types of image input generate the imagined concept images. The "input architectural content" and "input architectural style" create the output's "architectural concept image". Consequently, deep neural networks have developed the capacity to manipulate architectures in unexpected ways and grasp some notions about them. The research remains limited to exterior architectural images; however, the different scales of the interior spaces will hinder their use as input images. The researcher suggested an RGB+D picture of architectural space to overcome this struggle, which the RGB corresponds to colour information while D corresponds to depth information.

In 2018, Kim et al. proposed that deep learning can recognise interior design elements from digital images based on their design features (Kim et al. 2018). The chair is the target element, and the target design features comprise function, materials, seating capacity and design style. The paper demonstrated how to retrain the model to extract the features needed to efficiently manage and use such design information. There were 3933 chair images in the dataset, and six retrained image recognition models retrained the models. This model had a mean training accuracy of 94.3%, which proves higher than any other model.

In 2019, Yee Ng et al. investigated AI solutions that automatically identified and retrieved a set of AEC files stored in a company's document library (Ng et al. 2019). Convolutional neural networks (CNNs) can recognise patterns and features in large sets of technical drawings, such as sections, plans and elevations. Despite successfully classifying all images, the model failed to achieve this level of accuracy when tested on further inputs. Thus, the paper recommended further adjusting the model's hyperparameters before implementing it in a practice-based scenario. This model could also properly categorise digital or hand-drawn archival files that might have been forgotten in a company's storage but could still inspire knowledge and

Chapter 2: Literature Review

innovation. Furthermore, the model has the potential to distinguish between real pictures of a building and architectural visualisations based on specific features, such as abstract drawings, texts, and renders.

In 2020, Xiao et al. investigated the possibility of using deep learning to recognise and segment architectural components for automatic BIM modelling (Xiao et al. 2020). Preparing a dataset involves making images from an original CAD drawing with the labelled architectural components and then undertaking training and testing, which includes using a deep learning network trained on thousands of labelled images to make predictions. In 2D drawings, the researcher segmented images using "label-me" into five architectural components: walls, doors, windows, stairs and columns. Consequently, the current stage with recognisable element types can be considered successful with an accuracy rating of 80% and fast operation levels.

Studies have taken place to identify architectural drawings using a CNN. Uzun et al. used a CNN transfer learning algorithm to recognise architectural drawings, including plans and sections (Uzun and Çolakoğlu 2019). The paper used an object detection API model for transfer learning and had a small dataset size with 100 plans and 100 sections. Despite the small dataset, the trained algorithm could understand the logic and structure of architectural drawings.

Researchers have discovered that human brains have a focus similar to neural networks. (Hu 2021), introduced a method of extracting quantified style description vectors, used as input for computer analysis by using image-style classification. Architectural photos of three styles (Baroque, Byzantine and Gothic) trained the neural network. Besides this, the paper compared neural networks' cognitive characteristics and human beings.

Another approach discussed a technique that created intuitively modifiable 3D models from pictures (Silvestre 2016). A capture device created digital data representations of architecture. Computer vision algorithms (photogrammetry) and machine learning systems (ConvNet) refined them into parametric models. In photogrammetry, the input data consists of overlapping pictures. A homologous point between two pictures is calculated before a dense correlation is performed to create point clouds. A mesh triangulation algorithm connects the points of the cloud. Using this approach creates a 3D mesh. Despite employing two different algorithms, namely "Twin consensus segmentation network" and "Depth Feature Detector Deep Neural Network (ConvNet)," the author could not determine whether the system

worked. Such a situation could result from the plenoptic camera producing a depth map with numerous errors.

2.9.4. Graph Neural Network (GNN)

Although deep learning effectively captures hidden patterns in Euclidean data, graphs are used increasingly for expressing data. Graphs may have a variable number of nodes, and nodes can have different numbers of neighbours; because of the complex nature of graph data, existing machine learning algorithms face significant challenges. This complexity makes it easier to compute operations (e.g., convolutional) in the image domain than in the graph domain.

According to (Wu et al. 2019), it is possible to generalise a 2D convolution to a graph convolution. The (Figure 2.55) illustrates how an image can be viewed as a special type of graph connecting pixels to adjacent pixels. Similar to 2D convolutions, graph convolutions may be performed by taking the weighted average of a node's neighbourhood information. The 2D convolution, like a graph convolution, is an image that can be compared to a graph, where the filter size determines each pixel's neighbours. In 2D convolution (left), the red node and its neighbours are weighted averages. Nodes have ordered neighbours with a fixed size. However, the graph convolution (right) is an easy way to obtain a hidden representation of the red node by taking the average of its node features and its neighbours. Unlike image data, neighbouring nodes are unordered and variable in size.

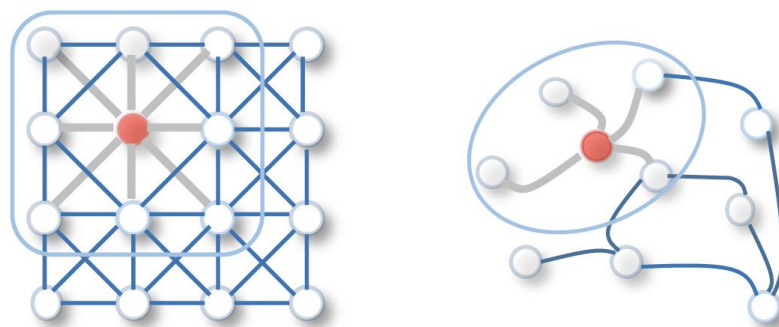

Figure 2.55: Left; 2D convolutional, right; graph convolutional

According to Wu et al. (2019), the GNNs can be categorised into Recurrent Graph Neural Networks (RecGNNs), Convolutional Graph Neural Networks (ConvGNNs), Graph Autoencoders (GAEs) and Spatial-Temporal Graph Neural Networks (STGNNs).

Understanding the above GNN categories requires understanding the history of GNNs. Early studies on GNNs were motivated by (Sperduti and Starita 1997), and their application of neural networks to directed acyclic graphs. The notion of graph neural networks was first

Chapter 2: Literature Review

described in (Goriet et al. 2005), and further developed in (Scarselli et al. 2009), and (Gallicchio and Micheli 2010). The early studies reported here fall into the category of recurrent graph neural networks (RecGNNs). An iterative process is used to learn the representation of a target node by propagating neighbour information until a stable fixed point is reached. This process is computationally expensive, and efforts are being made to overcome these challenges (Dai et al. 2018).

Motivated by the success of CNNs in the computer vision domain, many methods for defining convolution for graph data have been developed. There are two main approaches to converging GNNs: spectral-based and spatial-based. A spectral method uses ideas from spectral graph theory, such as computing the eigenvectors of the graph adjacency matrix. (Bruna et al. 2014), presented the first research on spectral-based ConvGNNs, which employed spectral graph theory to develop a graph convolution. Improvements and extensions have been made to spectral-based ConvGNNs since the beginning of this decade (Defferrard et al. 2016; Kipf and Welling 2017; Levie et al. 2018). Spatial methods, on the other hand, use graph convolution to update the representation of a vertex according to its neighbours. Spatial methods have proved more effective than spectral methods, meaning they are in wider use. The first study of spatial methods was by Micheli et al. in 2009, which addressed graph mutual dependency by using non-recursive architectural layers while borrowing notions of message passing from RecGNNs. Recently, several spatial-based ConvGNNs (Atwood and Towsley 2016; Niepert et al. 2016; Gilmer et al. 2017), have emerged. GNNs can focus on one or more graph analytics tasks based on the graph structure and using node contents as inputs (Wu et al. 2019):

- i. **Node-level:** The outputs relate to node regression and node classification. By using information propagation/graph convolution, RecGNNs and ConvGNNs can extract high-level node representations. However, the output layer of GNNs is a multi-perceptron or a SoftMax, which allows them to handle node-level tasks in an end-to-end manner.
- ii. **Edge-level:** To predict an edge's label/connection strength, can use the hidden representations from two nodes' GNNs as inputs to a similarity function/neural network.
- iii. **Graph-level:** Graph classification task. A GNN is often combined with pooling and readout operations to obtain a compact representation on the graph level.

Chapter 2: Literature Review

In an end-to-end learning framework, GNNs (e.g., ConvGNNs) can be trained in supervised, semi-supervised and unsupervised ways depending on the learning task and the available label information (Wu et al. 2019).

- i. **Supervised learning for graph-level classification:** Classification at the graph level aims to predict the class label of an entire graph. This task can accomplish end-to-end learning by combining graph convolutional layers, graph pooling layers and/or readout layers. In contrast to graph convolutional layers, graph pooling layers serve as down-sampling layers because they coarsen each graph into a substructure. In a readout layer, node representations are collapsed into graph representations. We can build an end-to-end framework for graph classification by applying a multi-layer perceptron and a SoftMax layer to graph representations (Ying et al. 2018; Zhang et al. 2018).
- ii. **Semi-supervised learning for node-level classification:** For a network with labelled and unlabelled nodes, ConvGNNs can learn a robust model that identifies the class labels for the unlabelled nodes. To achieve this end-to-end framework, graph convolutional layers are stacked before a SoftMax layer is used for multi-class classification (Kipf and Welling 2017).
- iii. **Unsupervised learning for graph embedding:** In an end-to-end framework without class labels, we can learn graph embedding in an unsupervised way. One approach involves embedding the graph into the latent representation with convolutional layers, which could be accomplished with an autoencoder, upon which a decoder would reconstruct the graph structure (Kipf and Welling 2016; Pan et al. 2018). Another way involves utilising a negative sampling method, which samples a portion of node pairs as negative pairs and treats existing node pairs with links as positive pairs. A logistic regression layer distinguishes between the positive and negative pairs (Hamilton et al. 2017; Bai et al. 2019a; Bai et al. 2019b; Sun et al. 2020).

2.9.4.1. Graph Embedding (Graph Representation Learning)

Graph embedding represents a method of mapping a graph into a fixed-length vector or matrix that captures a key feature while reducing the dimension. This approach means that graph embedding helps translate a complex graph into a form that a machine can use. Network embedding seeks to present network nodes as low-dimensional vector representations, preserving the network's topology structure and the nodes' contents, enabling subsequent graph analytics tasks, such as classification, clustering, and

Chapter 2: Literature Review

recommendation (Wu et al. 2019). Graph embedding ML models typically learn what is crucial in an unsupervised generalised way.

A. Graph Embedding Input

Three types of graphs can be used as input for graph embedding: homogeneous graphs, heterogeneous graphs, graphs with auxiliary information (Cai et al. 2018).

- i. **Homogeneous graphs**, feature nodes and edges that belong to the same type. According to whether the edges are weighted (or directed) or not, a homogeneous graph can fall into weighted (or directed) or unweighted (or undirected) categories.
- ii. **Heterogeneous graphs** exist in three scenarios. **Community-based question-answering (CQA) sites** offer a crowdsourcing service that allows users to post questions on the CQA website, which other users can answer (Fang et al. 2016). **Multimedia networks** contain multimedia data, such as images, text and so on. Users and images are embedded into the same space so that they can undergo direct comparison for image recommendations by exploiting user-image links (Wu et al. 2016). **Knowledge graphs** connect data from a variety of sources, organise information about entities of interest (like people, places and events) and develop connections between them. Several studies have implemented embedded knowledge graphs (Wu et al. 2015; Feng et al. 2016).
- iii. **Graphs with auxiliary information** include the following types: label, attribute, node feature, information propagation and knowledge base.

B. Graph Embedding Output

Graph embedding output comprises four categories based on output granularity: node embedding, edge embedding, hybrid embedding and whole graph embedding (Cai et al. 2018) (Figure 2.56).

- i. **Node embedding:** This category, also known as vertex embedding, describes each **node's connectivity**. Node embedding is a common embedding output setting that represents nodes as vectors in a low-dimensional space. Graph nodes that "neighbour" each other are embedded with similar vector representations. There are three commonly used metrics for calculating nodes' pairwise similarity: first-order proximity, second-order proximity, and higher-order proximity.
- ii. **Edge embedding:** Known as path embedding, which traverses across the graph. Edge embedding represents an edge as a low-dimensional vector. Edge embedding is

Chapter 2: Literature Review

advantageous for edge/node pair-related graph analysis, including knowledge graph entity/relation prediction.

- iii. **Hybrid embedding:** Hybrid embedding combines different types of graph components, such as nodes and edges. This embedding is also known as substructure embedding.
- iv. **Whole graph embedding:** This category seeks to encode the graph into a single vector (Cai et al. 2018). In the embedded space, two similar graphs are represented by one vector and are embedded close together. Whole graph embedding provides a straightforward and efficient way of calculating graph similarities, which proves essential to graph classification.

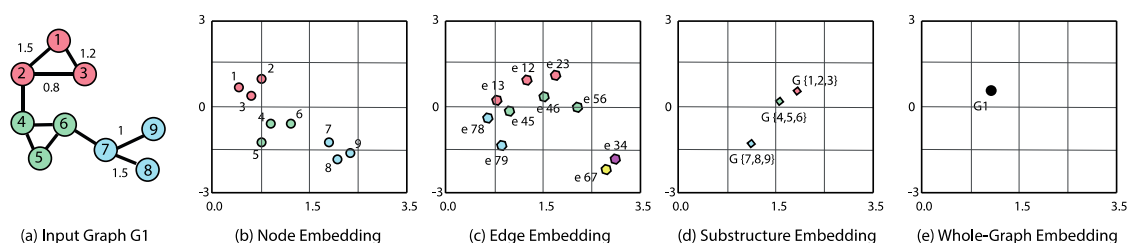

Figure 2.56: Example of embedding a graph into 2D space with different granularities, by author after (Cai et al. 2018)

In 2020, Yun-Sun et al. introduced InfoGraph, a machine learning model that studies the representations of whole graphs in unsupervised and semi-supervised scenarios (Sun et al. 2020). The unsupervised InfoGraph accomplishes this task by providing the number of nodes in G_i as $|G_i|$ and all graph matrix representations as $\Phi \in R^{|G| \times \delta}$. This notation is defining that Phi is a matrix which has $|G|$ rows and delta columns. $|G|$ equals the number of graphs and delta equals the size of the vector used to represent each graph. The purpose of using representation learning to learn a vector representation for each graph. These representations are stored in the matrix Phi (one matrix row for each graph).

The InfoGraph model focuses on graph neural networks (GNNs). Repeated aggregation of local neighbourhood node representations in embedding architectures produces node representations. By aggregating the features of neighbours, one can learn the representations of nodes, known as patch representations. In a GNN, the READOUT function summarises the obtained patch representations into a fixed-length graph representation.

The (Figure 2.57) illustrates the UGLRL model process: a) an input graph is encoded into a feature map with graph convolutions and jumping concatenation; b) (global representation, patch representation) pairs are input to the discriminator, which determines whether they

Chapter 2: Literature Review

belong to the same graph; and c) InfoGraph generates all possible positive and negative samples using a batch-wise fashion. For example, consider the two input graphs in the batch and seven nodes in total (above). The global representation of the green graph (A) will apply seven input pairs to the discriminator and the blue graph (B). In this case, the discriminator will take 14 (global representation, patch representation) pairs as input.

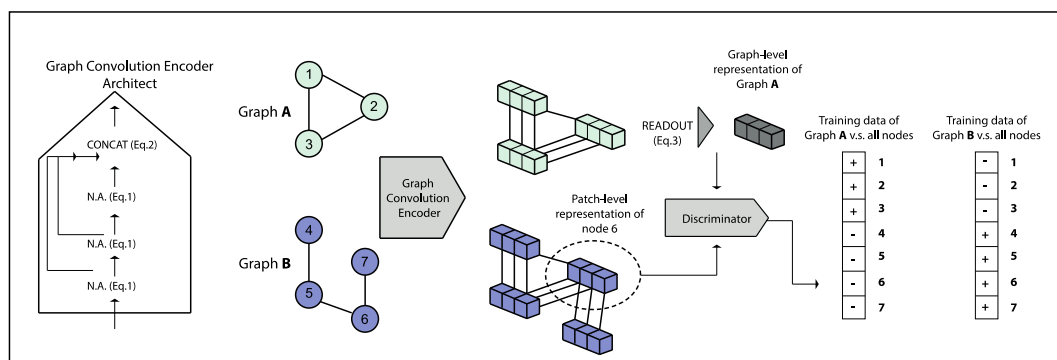

Figure 2.57: Unsupervised graph-level representation learning model (author after Sun et al. 2019)

2.9.4.2. Graph Convolutional Neural Networks (GCNN)

The "convolution" operation in GCNNs is essentially the same as in CNN. An input neuron is multiplied by a set of weights commonly referred to as a filter or kernel. CNNs learn features from neighbouring cells by using the filters as sliding windows across the whole image. Throughout an image, the same filter will be used in the same layer, referred to as weight sharing. Employing CNN to classify images of dogs versus non-dogs would use the same filter in the same layer to detect the animals' noses and ears. However, GNNs are the generalised version of CNNs, where nodes are connected differently and unordered (irregular on non-Euclidean data). CNNs are built to operate on highly structured data, whereas GCNNs are designed to operate on less standard structured data.

Graph convolutional neural networks were first introduced by (Bruna et al. 2014), who demonstrated the possibility of learning convolutional layers with a number of parameters independent of the input size, resulting in efficient deep architectures. In 2018, Xie and Grossman proposed a crystal graph convolutional neural network (CGCNN) that could learn the properties of crystal atoms (Xie and Grossman 2018). CGCNN offered highly accurate predictions of eight different properties of crystals.

In 2018, Chai et al. proposed a multi-graph convolutional neural network that could predict the bike flow at the station-level in a bike-sharing system. Their model could outperform state-of-the-art prediction models by reducing the prediction error by up to 25.1%. Li et al. (2018)

Chapter 2: Literature Review

proposed a Diffusion Convolutional Recurrent Neural Network (DCRNN), a deep learning framework for traffic forecasting that incorporated spatial and temporal dependency in the flow of traffic. Yu et al. (2018) proposed graph convolutional networks to predict traffic speed in road systems that consistently outperform state-of-the-art baselines on various real-world traffic datasets.

In 2019, Kipf and Welling introduced a scalable approach for learning on graph-structured data (Kipf and Welling 2017). Their model scaled linearly and could encode local graph structures and features of nodes. They showed that their approach outperforms related methods by a significant margin on datasets in the domain of citation networks. Although many domains have seen GNN successfully applied, their application in architecture remains relatively new.

2.9.4.3. Deep Graph Convolutional Neural Networks (DGCNN)

In 2018, Zhang et al. introduced an end-to-end deep-graph convolutional neural network (DGCNN) that accepted arbitrary graphs without first converting them into tensors (Zhang et al. 2018). DGCNN could accomplish this goal by first passing the inputted graph through multiple graph convolution layers where node information propagates between neighbours. A second layer then sorts the graph vertices in a consistent order, which are then inputted into a traditional convolutional neural network (Figure 2.58). By sorting the vertex features rather than summing them up, DGCNN retains more information, thus allowing it to learn from global graph topology. Furthermore, Zhang et al. provided theoretical proof that in DGCNN, if two graphs are isomorphic (i.e., have an identical structure), their graph representation after sorting the vertices is the same. This situation avoids the need to run additional costly algorithms to canonise the graph. Compared to state-of-the-art graph kernels, DGCNN has achieved highly competitive accuracy on benchmark graph classification datasets.

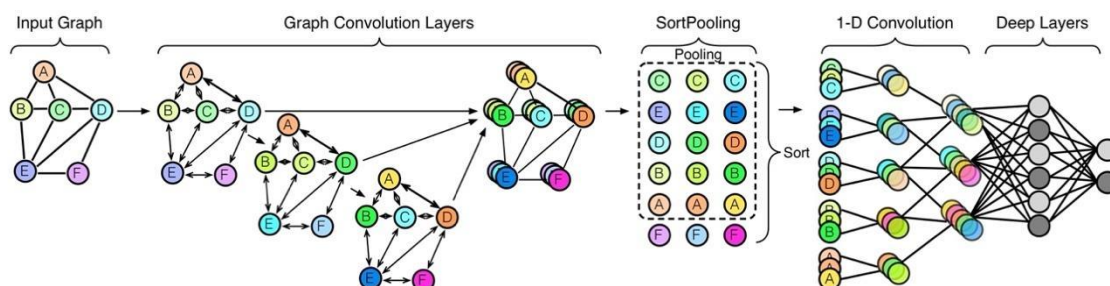

Figure 2.58: The structure of DGCNN (author after Zhang et al. 2018).

2.9.4.4. Application of the Graph Neural Network in Architecture

Derix and Jagganath developed ways to construct spatial typologies by associating spatial attributes with layouts. A building floor plan underwent analysis using isovists, centrality and visual connectivity concepts (Derix and Jagannath 2014). The model facilitated an experience-based approach to architectural and urban design by determining types and sequences of user experiences across buildings instead of strict typologies. To develop a reconfigurable exhibition space plan, Harding and Derix used a two-stage neural network and spectral graph theory as a spatial pattern recognition tool. Due to their capacity to act as a spatial pattern recognition tool, Harding and Derix used two-stage neural network and spectral graph theory to develop an exhibition plan. The researchers utilised spatial adjacencies to construct and classify plans and reduced the graph by finding its "graph spectrum" to facilitate its representation as a synaptic vector in feature space. Such an approach found that comparing graphs becomes significantly easier. A noteworthy aspect of their research is that they used this approach to automatically generate spatial layouts using a repulsion algorithm combined with a diagram that distributes graphs evenly on a boundary plan. To maintain node adjacency, topological connections were simulated as springs.

Beetz researched the use of graph databases for harmonised distributed concept libraries to build information models. He aimed to create "flexible, granular and cascading concept libraries for the building industry". This research sought to standardise the input data for graph neural networks (Beetz 2014).

Tamke investigated supervised and unsupervised ML approaches to deduce implicit information in BIM. His platform can extract literal values, aggregates, and derived values from IFC SPF files. Additionally, the system can perform geometrical and topological analyses that detect anomalies and divide floor plans into two groups based on their geometrical appearance (Tamke et al. 2016).

Ferrando et al. aimed to demonstrate how ML techniques may identify typological and functional traits from building plans based on a dataset of religious buildings. Their analysis of this dataset, via the use of ML techniques, allowed them to identify these buildings as mosques or monasteries and derive other insights into the connections between typology and spatial connectivity within them. This proposed method for classifying buildings based on their spatial structures achieved high levels of accuracy. Although this research dataset focuses on religious complexes, the authors are confident that this approach can be applied to other buildings and help answer other architectural questions (Ferrando et al. 2019).

2.10. Related Work

Table 2.1: A review of studies concerning the relationship between the building and the ground

Study	Aim	Methodology	Main Findings
"Uncommon ground: architecture, technology, and topography" (Leatherbarrow 2000).	By examining how works of modern architecture addressed site and context issues, the researcher contributes to the postmodern recovery of the landscape.	Through carefully examining buildings designed by three mid-20th-century architects, Leatherbarrow has contributed to Frampton's scholarship on the manner in which technological and topographical conflict was understood and addressed within these buildings.	In his essay, Frampton alluded to the idea that an architect reaches a regional expression through creative making rather than simply observing site conditions and following local building practices. Leatherbarrow illustrates this idea through his use of technology rather than observing site conditions and following local building practices. Moreover, in exploring the relationship between site and building, the book contributes to the growing literature that expands and enriches the history of modern architecture.
"Topographical Stories: Studies in landscape and architecture" (Leatherbarrow 2004)	The fields of landscape architecture and architecture are closely related. Some have posited that they belong to the same field. Others believe the disciplines are distinct. Theorists and practitioners debate these designations constantly. Leatherbarrow discusses this argument using different architectural case studies.	Leatherbarrow used approximately 100 illustrations to support this rigorous argument, including examples of topography from the sixteenth, eighteenth, and nineteenth centuries, early modernism and more recent works.	The purpose of landscape architecture and architecture, according to Leatherbarrow, is to accommodate and express the patterns of our lives. His view of topography includes not only terrain, built and unbuilt, but also traces of practical matters, by which culture preserves and renews its usual situations and institutions
"Architectural Topographies: a graphic lexicon of how buildings touch the ground" (Berlanda 2014).	The research objective is to help identify, analyse, select and invent solutions to the problem. The book's keywords refer to "the physical and material relationship between building and ground"; where and how the link is generated; the physical criteria, methods and tools used to know and transform the land; and possible methods	To demonstrate how the keywords might be combined, and to illustrate each architect's position on their built work in relation to the others, the book examines fifty case studies by forty-six of the greatest architects of the past hundred years, which are presented in sectional drawings which place the buildings on a common ground plane.	Using explanatory texts and built architectures establishes a relationship between heterogeneous elements to understand and explain works and statements, constructive details and differing worldviews. Consequently, the dichotomy between abstract pronouncements and architectural concepts should be overcome.

Chapter 2: Literature Review

Study	Aim	Methodology	Main Findings
"Grounds and envelopes: Reshaping architecture and the built environment" (Hensel and Turko 2015).	<p>of transforming the land based on the place's characteristics.</p> <p>The researcher aims to provide a vision for the revitalisation of the ground and envelope as spatial elements employable in the search for embedded local architectures.</p>	<p>Using a methodological approach to integrating essays and projects, Hensel provides a nuanced and rich understanding of the spatial organisation.</p>	<p>According to Hensel and Turko in 2015, efforts need to be made to reignite spatial thinking, discourse and design in architecture and identify the traits of what can be described as an architecture intensively embedded in the local context. In other words, a non-discrete architecture eschews the disengaged object as the primary objective of architectural design. Four theoretical reflections and discussions related to key concepts and potentials of non-discrete architecture design are discovered here. The first, space, focuses on the role of sectional approaches and arrangements in spatial organisation. The second, ground shape, sees the concept of multiple and provisional grounds discussed along with questions pertaining to the ground. The third point, by generating, providing and modulating heterogeneous milieux and microclimates, the building and ground can widen the scope of provision for use and habitation based on local climate conditions. The fourth, locality, aims to synthesise various aspects of the previous chapter to create architectures that may once again be regarded as intensely local.</p>
"Contested terrain" (Porter 2015).	<p>Recent efforts to integrate architecture and landscape have heightened the importance of historical analysis of the forces shaping contemporary discourses and practices. The paper aims to provide a broader</p>	<p>A comparative analysis of theories of ground with the sociology of professions provides a broader historical context for contemporary</p>	<p>According to the researcher, professional jurisdiction provides an excellent context for understanding historical relationships between the ground and the building.</p>

Chapter 2: Literature Review

Study	Aim	Methodology	Main Findings
	historical context for current debates about architecture and landscape design.	architectural and landscape design discussions.	
"Architecture ≠ andscape: The case against hybridization" (Porter 2017).	Despite growing interest in combining architecture and landscape architecture, this essay argues against it. To maintain the legibility of public and private spaces, such a division is deemed necessary.	This essay examines two opposing conceptions of the ground within contemporary urbanism-continuous and discrete-by using examples and case studies.	Architecture and landscape architecture play a critical role in the contemporary city's political structure, according to this essay. This paper argues for discrete approaches to ground, which allow architects to maintain a critical position in relation to the city.
"Dig it! building bound to the ground" (Mastenbroek et al. 2021).	In the physical sense, a building is rooted in the ground, permanently fixed, and enduring. Mastenbroek, Bjarne, research has illuminated fascinating examples of this philosophy - some well-known, some previously unknown.	The book method uses case studies to conduct analysis, and an extensive collection features analytical drawings from SeARCH and photo essays.	Efforts have been made to reconnect architecture and landscape and integrate buildings into the landscape, through Bury, Embed, Absorb, Spiral, Carve, and Mimic techniques. This remarkable survey reveals humanity's link to the earth through building culture.

Chapter 2: Literature Review

Table 2.2: A review of studies of using machine learning approaches to cluster similar architectural style precedents

Study	Aim	Methodology	Main Findings	Limitations and Future Works
"On classifying daylight for design" (Glaser and Peng 2003b).	This paper examines the LiQuID tool, which clusters lighting simulation data. Glaser and Peng, aims to reduce large complex sets of photographs by classifying them into representative prototypes.	The proposed method involves clustering the data based on similar data and grouping the numerical or visual data to reduce the problem. LiQuID uses a K-means clustering algorithm to divide the data into two categories.	LiQuID and Light Sketch tools help architects create a quick design and decide on the building's light quality.	However, these methods encounter several issues. Firstly, the illuminance data is not considered in the classification. Secondly, the visualisation of clusters requires further development. Finally, the similarities between larger temporal units need to be addressed.
"Architectural style classification of building facade windows" (Shalunts, Gayane, Yll Haxhimusa 2011).	To build a machine vision system for classifying windows according to architectural styles. According to the type of windows they contain, Romanesque, Gothic and Renaissance/Baroque architectural periods in Europe are classified.	By clustering and learning local features, the approach employs the intelligence architects use in training to classify windows according to architectural styles. Researchers used local image features and descriptors to cluster windows based on architectural styles employing the K-means algorithm.	The proposed approach achieves a high classification rate, as demonstrated by the experiments.	Some of the cases were clustered in the wrong classes because of the complexity of the architectural details.
"Classification of gothic and baroque architectural elements" (Shalunts et al. 2012).	Describes the problem of classifying Gothic and Baroque architectural elements such as tracery, pediment and balustrade.	Clustering and learning local features comprise the key components of this approach.	The proposed approach achieves a high classification rate, as demonstrated by the experiments.	This paper is limited to a small number of architecture-style classes. Studies should increase the number of architectural styles classified in the future.
"Architectural style classification using multinomial latent logistic regression" (Xu et al. 2014).	This paper applies Deformable Part-based Models (DPMs) to capture architectural component morphology.	In this paper, the researcher proposes the Multinomial Latent Logistic Regression (MLLR), which introduces latent variables into logistic regression.	The Deformable Part-based Model (DPM)-MLLR algorithm performed best with highly distinguishable facades of architectural styles based on experiments with a large-	

Chapter 2: Literature Review

Study	Aim	Methodology	Main Findings	Limitations and Future Works
"Analysing populations of design variants using clustering and archetypal analysis" (Chen et al. 2015)	Experiments examining the resulting population of alternate designs and providing insight into the relationship between architectural features and design performance.	Chen et al. used two-stage methods. A k-means clustering algorithm, once the clustering had been created (Archetypal Analysis), was used to partition the population of design variants into clusters and then extract exemplars for each group	scale dataset of architectural styles. The experiments show that it is possible to gain general knowledge by linking architectural features to design performance.	. Moreover, it does not seem to have any architectural features, which, in turn, makes it complicated to conclude anything in terms of performance.
"Cultural difference in colour usages for building facades focusing on theme park buildings" (Lee and Lee 2016).	An investigation into the colour pattern difference between Eastern and Western cultures using a case study of Disneyland Paris and Tokyo Disneyland.	Lee and Lee, used image-based k-means clustering algorithms and CIELAB colour space to investigate the colour properties.	The results indicate that the former used green and bluish colours while the latter featured more red and yellowish colours based on CIELAB colour space values.	paper encountered difficulties obtaining building images due to trees or visitors in the park. Therefore, higher resolution images can provide improved results.
"Clustering forms for enhancing architectural design optimization" (Yousif and Yan 2018)	The aim here is to make the decision-making process and form evaluation easier for the architect, which helps improve existing models in the architectural field.	This paper proposes two methods. Firstly, classification design solutions according to their geometric correspondence, increasing differences and imposing diversity. Secondly, using a K-means cluster algorithm to aggregate the resulting design forms into groups of similar models and replace each group with a single representative solution.	The model diversity algorithm has successfully filtered out highly diverse forms.	The main limitation is that K-means clustering is still preliminary. Therefore, more experiments are needed to examine the results; K-means visual representation is also required. However, that could prove tricky because there were ten dimensions.

Chapter 2: Literature Review

Table 2.3: A review of studies' classification of architectural works using graph topological machine learning in architecture design

Study	Aim	Methodology	Main Findings	Limitations and Future Works
"A new model for learning in graph domains" (Goriet et al. 2005).	Consequently, topological information may be lost, and the results may be heavily affected by pre-processing. This paper presents a new neural model capable of directly processing graphs: the graph neural network (GNN). Numerous graph types, including undirected, directed, labelled and cyclic, can be used with GNNs, including recursive neural networks.	A novel neural model called graph neural network (GNN) is presented. The graph neural network extends the capabilities of recursive neural networks since it can evaluate a wider set of graphs and use them.	The model shows its promise based on preliminary experimental results.	Future research will focus on experimenting with the approach for larger applications.
"A scalable network of concept libraries using distributed graph databases" (Beetz 2014).	This research seeks to standardise the input data for graph neural networks.	Beetz, use these models to classify types and sequences of user experiences across buildings rather than strict typologies, thus enabling an experience-based approach to architectural and urban design.	Several use cases are presented and discussed that illustrate the potential applications of such systems.	Some of these approaches are currently in the process of being specified, prototyped, evaluated and tested.
"Assessing implicit knowledge in BIM models with machine learning" (Tamke 2015)	Tamke has investigated supervised and unsupervised ML approaches to deduce implicit information in (BIM).	His platform can extract literal values, aggregates, and derived values from IFC SPF files. Additionally, the system can perform geometrical and topological analyses that detect anomalies and divide floor plans into two groups based on their geometrical appearance.	It is possible for non-technical users to query complex BIM datasets for highly practised and project-specific insights with the help of machine learning.	
"Tracking changes in buildings over time- fully automated reconstruction and	This paper aims to detect differences between 3D scans and 3D models of buildings.	Tamke has investigated supervised and unsupervised ML approaches to deduce implicit information in (BIM).	His platform can extract literal values, aggregates and derived values from	It proved challenging to import IFC files into BIM modelling software (Rhino with Visual Arq plugin). Such an issue possibly resulted from the

Chapter 2: Literature Review

Study	Aim	Methodology	Main Findings	Limitations and Future Works
difference detection of 3d scan and BIM file" (Tamke et al. 2016).			IFC SPF files. Additionally, the system can perform geometrical and topological analyses that detect anomalies and divide floor plans into two groups based on their geometrical appearance.	plugin, which was clearly indicative of IFC format ambiguities.
"Architectural distant reading using machine learning to identify typological traits across multiple buildings" (Ferrando et al. 2019).	Ferrando et al. aim to demonstrate how machine learning techniques may identify typological and functional traits from building plans based on a dataset of religious buildings.	Ferrando et al, analysis of this dataset, using ML techniques, allows them to determine whether these buildings are mosques or monasteries and derive other such insights into the connections between typology and spatial connectivity within them.	This proposed method for classifying buildings based on their spatial structures has achieved high levels of accuracy.	Although this research dataset focuses on religious complexes, they are confident that this approach can apply to other buildings and help answer other architectural questions.
"Digital intuition – Autonomous classifiers for spatial analysis and empirical design" (Derix and Jagannath 2014)	Derix and Jagganath have developed ways to construct spatial typologies by associating spatial attributes with layouts. A building floor plan underwent analysis using isovists, centrality and visual connectivity concepts. The model facilitates an experience-based approach to architectural and urban design by determining types and sequences of user experiences across buildings instead of strict typologies.	To develop a reconfigurable exhibition space plan, Harding and Derix used a two-stage neural network and spectral graph theory as a spatial pattern recognition tool. Due to their ability to act as a spatial pattern recognition tool, Harding and Derix used a two-stage neural network and spectral graph theory to develop an exhibition plan. The researchers utilised spatial adjacencies to construct and classify plans and reduced the	Such an approach means that comparing graphs becomes significantly easier. A noteworthy aspect of their research is their use of this approach for automatically generating spatial layouts using a repulsion algorithm combined with a diagram that distributes graphs	

Chapter 2: Literature Review

Study	Aim	Methodology	Main Findings	Limitations and Future Works
"Architectural drawings recognition and generation through machine learning" (Huang and Zheng 2018).	The authors examine the idea of designing by data where machine learning acts as a decision-making tool. They choose machine learning to analyse big image data and generate output drawing data. The researchers aim to generate architectural plans using the Generative Adversarial Network (GAN) tool in machine learning.	Their method involves applying the pix2pixHD tool, a modified version of GAN, to recognise and generate apartment floor plans. They conducted an evaluation and experiment process to achieve that goal. Firstly, a labelling principle defined different functions with varying colours. Then, they trained the network at the beginning by using coloured floor plans of apartments as input and colour-marked maps as output. Next, the team trained another network by doing the process in reverse, which labelled maps as input and floor plans as output.	graph by finding its "graph spectrum" to facilitate its representation as a synaptic vector in feature space. evenly on a boundary plan. The simulation of topological connections as springs-maintained node adjacency. According to the findings, the network becomes more precise and accurate in generating the architectural plan drawing after the network gets deep and more data is trained. Through their experiment and analysis, the researchers found similar learning processes between human and machine learning. Additionally, they posited that artificial intelligence would play a role in the future by generating creative works rather than repetitive ones. Humans will be able to expand in a creative way once they are combined	The authors suggest that the experiment can develop further into "prototypes of powerful tools for drawing review, digitalization, and drawing assistance". Their next step would involve training the network to recognise and generate drawings faster and help architects become more creative.

Chapter 2: Literature Review

Study	Aim	Methodology	Main Findings	Limitations and Future Works
"Visual Architectural Topology: An ontology-based topological tool for use in an architectural case library" (Lin 2013).	This paper seeks to develop a "Visual Architectural Topology" (VAT) tool that encodes topological information within a case library.	The methodology process is as follows: Retrieval involves selecting a case, such as a section image from a case library; Identification involves identifying design objects, such as schematic spaces; Encoding involves assigning topological relationships between identified design objects; Validation involves validating assigned topologies and resolving conflicting topologies; Ontology involves assigning semantic annotations to explain topologies.	with artificial intelligence. Unstructured information, such as pictures or plans of a design case, can be annotated by VAT with design objects and topological information.	
"A graph deep learning approach for urban building grouping" (Yan et al. 2020).	In this study, multiple cognitive features and manual cartographic experiences were integrated to develop a grouping approach using graph deep learning.	The methodology starts with building centre points as nodes, with adjacent buildings arranged in a graph according to cognitive variables, such as size, orientation and shape, defined for each node. An analysis of the adjacent buildings modelled by the graph uses graph convolution and a neural network. A k-means algorithm groups graph nodes based on the predicted position of group centre points.	According to the experiments, the proposed approach performs better than existing approaches using the ARI index in detecting the intrinsic features describing building groupings.	The GCN model should undergo improvement (e.g., by adding the pooling operation and optimising the network architecture) to encourage new research in this area.
"Comparative evaluation of tensor-based Data	Eisenstadt et al. propose a workflow to apply deep learning techniques to architectural	Their adopted methods first involve converting the original floor plan and its Semantic	Their results indicate that the model could process and	

Chapter 2: Literature Review

Study	Aim	Methodology	Main Findings	Limitations and Future Works
representations for deep learning methods in architecture" (Eisenstadt et al. 2021a).	design problems during the early design phase to enable the auto-completion of unfinished designs. Their paper addresses the challenge of transforming semantic building information into a tensor format that libraries can interpret. Eisenstadt et al. focus on sharing information regarding the type of rooms within a building and the type of connections between them.	Building Fingerprint (SBF) into a multi-layer map, one-hot encoded map and a textual map. Subsequent classification helps evaluate all three approaches.	comprehend the latent structure of the select relation map types and their data.	
"CUBIGRAPH5K: Organisational graph generation for structured architectural floor plan dataset" (Lu et al. 2021).	Lu et al. propose a novel synthetic workflow for synthetically generating room relation graphs from structured architectural datasets. The workflow aims to synthesise a graph representation of the room relationship structured floor plan data by extracting geometric information.	Lu et al, present a method for decomposing vectorised floor plans to generate the intended organisational graph for further graph-based deep learning.	The proposed workflow has two main limitations. Due to its high dependence on vectorised floor plans, it was only tested with CubiCasa5K with properly labelled SVG files. The second problem is that the paper's room relationship definition does not consider cross-level connections, which means it only applies to single-floor floor plans.	This approach means future research can train neural networks on enhanced floor plan parsing, analysis and generation.
"A Framework for a comprehensive	This paper proposes a framework for constructing a	The framework methodology consists of two modules that	Since the paper re-utilised three	

Chapter 2: Literature Review

Study	Aim	Methodology	Main Findings	Limitations and Future Works
conceptualization of urban constructs" (Ezzat 2020).	knowledge base of urban constructs based on an ontology of urbanism.	represent the concepts or features of the materialisation of an urban construct. Spatial Net represents concepts as a knowledge graph (KG), while Spatial Features Net represents physical features as a deep neural network (DNN).	different pre-trained CNN models, this approach is currently feasible.	
"Exploring optimal ways to represent topological and spatial features of building designs in deep learning methods and applications for architecture" (Eisenstadt et al. 2021).	To enable auto-completion of unfinished designs, this research harnesses deep learning techniques to support early design problems.	First, they converted the original floor plan and its Semantic Building Fingerprint (SBF) into a multi-layer map, a one-hot encoded map and a textual map. The three approaches then underwent classification to evaluate their effectiveness.	Based on a classification task, a preliminary evaluation of deep learning networks shows that all formats are suitable. Validation accuracy of 98% was achieved for the one-hot encoding map.	
"GAN as a generative architectural plan layout tool: A case study for training DCGAN with Palladian plans and evaluation of DCGAN outputs"(Uzun et al. 2020).	In this study, generative adversarial networks (GANs) generate Andrea Palladio's architectural plans autonomously. This study aims to evaluate the effectiveness and performance of the GAN algorithm as a generative system for drawing architectural plans.	To automate plan production, Uzun et al., used deep convolutional generative adversarial networks (DCGANs), a subset of GANs. To train DCGAN, the researcher used two different datasets. The first dataset contained original villa plans created by Andrea Palladio (16th century). In the second dataset, Palladian grammar rules generated Palladian plans.	According to the findings, GAN is driven by probabilistic models rather than geometric similarities (shapes). Even so, GAN can generate statistically and geometrically accurate models.	In this regard, it remains important to remember that GAN algorithms produce statistically close visual models rather than geometrically close ones.
"Architectural Drawing Recognition: A case study for training the	This paper presents a case study of architectural drawing recognition.	This is accomplished by training the algorithm on a labelled pixel-based dataset of	According to the paper, it is possible to classify pixel-based	To predict drawing images accurately, the dataset must be

Chapter 2: Literature Review

Study	Aim	Methodology	Main Findings	Limitations and Future Works
learning algorithm with architectural plan and section drawing images" (Uzun and Çolakoğlu 2019).		architectural drawings (plans and sections). Transfer learning (pre-training model) is applied during training. Convolutional neural networks and supervised learning are used.	plan and section drawings. Algorithms can correctly predict the drawing class with 80% accuracy when they are shown sections not produced by conventional drawing techniques.	ordered by sample resolution, size and coherence.
"3D object classification using geometric features and pairwise relationships" (Ma et al. 2018).	Research presented here developed a tailored matching algorithm to accurately classify 3D objects based on expert knowledge of shape features and pairwise relationships.	This approach comprises three main steps: representing domain experts' knowledge of object classification using features, identifying the shape and spatial features of 3D objects and classifying objects using mathematical computations.	Three-dimensional bridge objects were classified using an integrated approach employing two models: a model with incorrect object types and a model manually reconstructed from point cloud data. The classification of all these objects proved successful.	However, as of now, machine learning for 3D object classification suffers from a lack of BIM models. Considering that most new projects are built using BIM models, machine learning may be used in the future to automatically create the implicit knowledge bases for object classification.
"Exploring graph neural networks for semantic enrichment: Room type classification" (Wang et al. 2022).	This paper aims to develop and test a novel approach to the semantic enrichment of BIM models, representations of models as graphs and the use of graph neural networks (GNN).	An apartment layout dataset with 224 apartment layouts, nine room types and edge/node features were compiled. To improve efficiency, a batch method processes node and edge features with an improved GNN algorithm, SAGE-E.	Adopting graphs and GNNs represents a viable approach. SAGE-E achieves higher accuracy (79%) and more balanced prediction. Moreover, the validation and training processes are	According to this research, researchers can explore the use of GNNs for more challenging intelligent functions in graph-format BIM models.

Chapter 2: Literature Review

Study	Aim	Methodology	Main Findings	Limitations and Future Works
"Assessing IFC classes with means of geometric deep learning on different graph encodings" (Collins et al. 2021).	Interoperability issues or losses in data exchange can significantly hinder their availability. It is common for the exchange format IFC to have incorrect or imprecise semantics, which complicates knowledge extraction. This paper aims to support the automated correction of IFC objects.	The paper uses Geometric Deep Learning (GDL) to perform classification based solely on 3D shapes. Convolutional Graph Networks (GCNs) create meaningful local features based on the native triangle meshes.	shortened using SAGE-E. Based on the self-assembled, partially industry dataset, the method achieves an accuracy level of 85%.	The lack of publicly available data is a recurring limitation. Most likely, the network shows a bias toward vendor-specific equipment types. This work assumes semantically correct elements in IFC models. The data consistency has only been checked visually.

2.11. Chapter Summary

The researcher divides the literature review into three major topics to find the research gap. The research starts out broad and then becomes more specific. Firstly, a review of studies focuses on the relationship between the building and the ground. Secondly, a review of studies using machine learning approaches to cluster similar architectural style precedents. Thirdly, there is a review of the classification of architectural works using graph topological machine learning in architecture design (Figure 2.59).

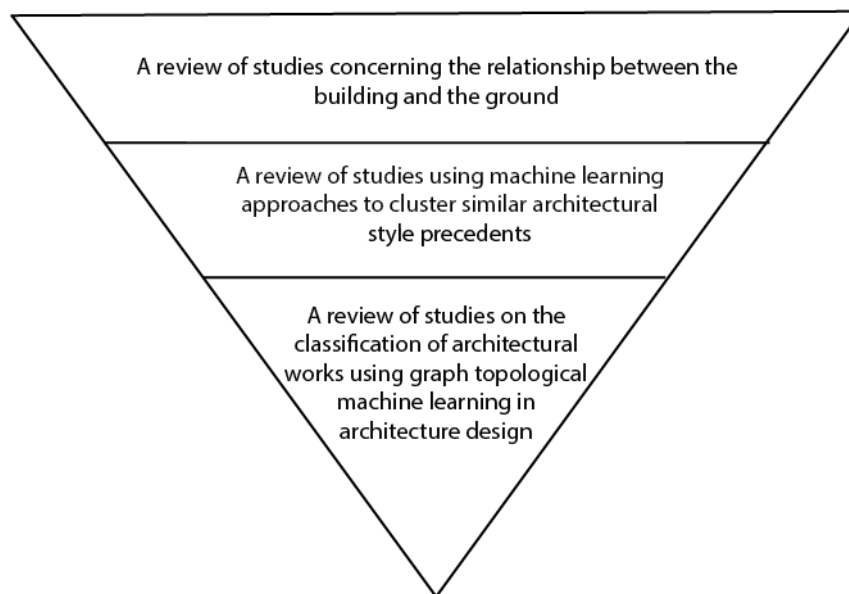

Figure 2.59: Literature review topics range from broad to specific related work.

2.11.1. A Review of Studies Concerning the Relationship Between the Building and the Ground (Table 2.1)

Following reviews of numerous studies focusing on the building and ground relationship, the findings showed that previous work assessed the issues from a theoretical point of view. The theoretical researcher used the case study methodology as an instrument to explain the relationship between the building and the ground. Although this approach focuses on specific research questions within the context of a particular environment, group or building type, in addition to real-life situations, it proves tricky to replicate, since it relies on the theoretical researcher's point of view, and in some cases cannot be generalised. Several researchers used illustrations, diagrams, and images to support their arguments. However, the relationship between the building and ground is complex, 3D and topologically connected. Hensel and Turko (2015) argued that the building and ground relationship is a non-discrete architectural

Chapter 2: Literature Review

design that avoids the disengaged object as its primary design objective. Thus, the building and ground relationship involves more than one theoretical key concept. There are four key concepts to consider in this topic: spatial organisation, ground shape, environment, and locality. Porter (2017) argued against the growing interest in combining architecture and landscape architecture in contrast to Hensel and Turko (2015). Besides these theoretical arguments and ideas and acknowledging that different key concepts affect the building and ground relationship, this research has focused on the physical relationship between the building and the ground.

2.11.2. A Review of Studies Using Machine Learning Approaches to Cluster Similar Architectural Style Precedents (Table 2.2)

Following reviews of numerous studies on using machine learning approaches to cluster similar architectural style precedents, the findings show that previous work has been limited to classifying and clustering architectural styles using images. Even though these approaches are interesting, they do not allow the machine to cluster the data without supervision or the tagging of images by humans. To the best of the author's knowledge, no work has been conducted using unlabelled data (unsupervised) to cluster architectural styles to clarify the relationship between different architects' building styles and the ground. Numerous studies implemented the clustering task using the K-Means algorithm as a machine learning method. The K-Means algorithm showed its effectiveness in achieving the researchers' objectives.

2.11.3. A Review of Studies on the Classification of Architectural Works Using Graph Topological Machine Learning in Architecture Design (Table 2.3)

According to the review of several studies, machine learning techniques have typically classified architectural works based on 2D pixels. There has been a long-standing interest in understanding and classifying architectural forms (Steadman et al. 2000). Several studies have shown the effectiveness of quantitative and statistical methods aided by computational tools in morphological research (Gil et al. 2012). Despite their limited impact on mainstream practices of architectural design, machine learning technologies have shown signs of revolutionising the recognition and classification of architectural forms. The adoption of these technologies still faces several challenges. Firstly, large datasets with labels are required for supervised machine learning. Secondly, most machine learning systems use pixels-based 2D image recognition (Shalunts et al. 2012; Shalunts, Gayane and Yll Haxhimusa 2011; Yoshimura et al. 2019). Even though this approach may seem reasonable given the available data, primarily plans and drawings, it encounters major limitations. Due to these limitations, most

Chapter 2: Literature Review

machine learning systems do not understand the semantics of the image they recognise. The study review also revealed a shortage of distributable 3D data since open-source sets are not uniform in their formats, appropriateness, usability, or licences (Collins et al. 2021; Gröger and Plümer 2012; Ma et al. 2018).

In spite of the availability of 3D datasets, it has become challenging to recognise and classify them. In a recent study (Sarkar, Varanasi and Stricker 2017; Kasaei 2019), researchers investigated whether three-dimensional models could identify features based on representations in two dimensions. However, this approach misses the 3D topology incorporated into the data. In a slightly more sophisticated approach, features from a 3D model are encoded as a vector that can act as input to a neural network (Qin et al. 2014). This approach extracts only a portion of the data, and it must be transformed into a standard input vector. The topological information that can indicate the type of object is ignored.

A promising approach involves using machine learning on graphs (Vishwanathan et al. 2010; Kriege and Mutzel 2012; Orsini et al. 2015). Several approaches face the limitation of decomposing graphs into small substructures, such as walks or paths, and calculating similarities between graphs based on a summation of attributes. The Deep Graph Convolutional Neural Network (DGCNN), Deep Graph Library (DGL), and Unsupervised Graph-level Representation Learning bypass such restrictions by offering a machine learning model that categorises graph-based information. These networks prove beneficial because they accept graphs without changing the data into vectors. Using these machine learning methods produces the following benefits: 1) grouping architectural precedents building and ground relationship approaches into similar classes to increase the availability of the architecture precedent resource; 2) classifying 3D conceptual models based on their topological graphs rather than on their 2D representation.

CHAPTER THREE

RESEARCH DESIGN AND METHODOLOGY

Chapter 3: Research Design and Methodologies

3.1. Chapter Overview

Conducting research forms the groundwork for asking a question. The ways of asking questions are crucial and applying the most suitable methods will certify that the answers provide a unique contribution to knowledge. This contribution will help the researcher establish a large overview of the discipline rather than repeating established knowledge or finding no clear solution (Lucas 2016).

In order for architecture research to progress, the researcher must uncover a suitable strategy to answer the research questions. In section (3.2), research paradigms and theoretical research approaches undergo review. Section (3.3) reviewed a philosophical foundation of mixed methods research. Accordingly, a specific research framework, stages, methods, techniques for collecting data and analysis techniques are presented in section (3.4) to confirm that all research aims, and objectives have been sufficiently and methodically addressed. Additionally, these three sections (3.2, 3.3, and 3.4) provide crucial context for the targeted audience, which includes academic peers, students, and lecturers. If the reader is already familiar with this information, it is advisable to move on to Section 3.5, which discusses the research framework.

3.2. Research Paradigms and Theoretical Approaches

Philosophically, researchers start their projects with 'knowledge claims' or 'paradigms'. Paradigms describe a group of assumptions, beliefs, models, and techniques for gathering and analyzing information (Teddlie and Tashakkori 2009), which are defined as a set of assumptions, beliefs, models, and techniques for gathering and analyzing information (Neuman and Robson 2014). Several scholars have argued that 'knowledge claims' refer to the following considerations (Della Porta and Keating 2008; Groat, and WanG 2013; Creswell 2014; Kumar 2014; Bryman 2016):

- **Ontology:** What do researchers need to know? Objectivism involves understanding social phenomena as external facts that exist independently of the researcher (finding the nature of reality) or constructionism involves understanding others' perspectives on reality, which is subjective, and social facts and their meanings are continuously processed by participants that define research questions (finding the nature of reality).

Chapter 3: Research Design and Methodologies

- **Epistemology:** What do research want to know, and how do they know the information is real? Next, we examine three epistemological viewpoints: positivism, interpretivism, and pragmatism.
- **Methodology:** What are the stages and processes involved in conducting research or 'modes of inquiry'? In collecting data and conducting research in the real world, three methodological approaches are available: (i) ethnography and phenomenology, using qualitative methods; (ii) surveying, using quantitative methods; and (iii) mixed methods.
- **Interpretation:** How the results should be interpreted and analysed to achieve the study's goals.

3.3. Philosophical Foundations of Mixed Methods Research

According to this study, we need to approach problems openly to find solutions based on the pragmatist perspective of our world. Since there is no prior research on this side of the issue, the researcher must focus on the research questions rather than questioning the ontology and epistemology (Wahyuni 2012). Several authors claim that combining quantitative and qualitative methodologies will overcome the weaknesses of either method with the strengths of the other (Johnson and Onwuegbuzie 2007; Creswell 2009; Creswell 2014). This pragmatic thinking means researchers can use interpretivist positivist philosophy instead of becoming fixated on defining their research philosophy. According to positivists, the most salient way to confirm the solution involves methods that will verify it in either case. Interpretivists adhere to a constructivist approach. For the purposes of conducting their research, researchers should have the means to choose from various paradigms and methods.

3.3.1. Positivism Paradigm:

Positivism traditionally believed that social reality was based on objective facts derived from natural science. Consequently, the researcher remains independent from the phenomenon under study, and their views and beliefs have no bearing on the results (Kincheloe and Tobin 2009). Furthermore, positivists believe that scientific methods and techniques represent the best means of discovering the truths of the universe. These methods and techniques seek to determine the extent of the phenomenon by measuring, quantifying, or quantifying it (Mukherji and Albon 2018). To collect numerical data, the researcher formulates a set of hypotheses or research questions. Afterwards, the researcher analyses the data to test or disprove these hypotheses or answer research questions (Naughton et al. 2001). The positivist approach emphasises the importance of stating hypotheses and testing them with empirical data to see if they are supported (Christensen et al. 2011). It is possible to generalise

Chapter 3: Research Design and Methodologies

quantitative research results over time because the context does not affect them (Bassey 1999).

3.3.2. Interpretivism Paradigm:

Qualitative research is based on an interpretive foundation (Mukherji and Albon 2018). According to interpretivism (Wahyuni 2012), multiple realities exist, and subjective methods evaluate those realities. Researchers need to establish direct contact with individuals who can provide data about these multiple realities from their perspective to gain a deeper understanding of them (Mack 2010; Christensen et al. 2011). It is possible to discover deeper meanings in research subjects through the interaction between the researcher and the participant. From an axiological perspective, interpretivists take the participants' perspectives (Christensen et al. 2011). Researcher and participant experiences and values influence data collection and analysis (Wahyuni 2012). Interpretivism lacks generalisation outside of its study context (Mack 2010), which constitutes one of its weaknesses. It has become possible to achieve generalisability in qualitative research by examining the same topic from different perspectives (using several interview participants' perspectives), thereby determining the generalisability of the findings (by comparing them).

Research approaches and paradigms that differ in their epistemological and methodological characteristics have led to the debate that they should never be combined. (Smith 1983), believes the two methods should not be deemed complementary based on different epistemological implications. This study demonstrates that researchers can collect appropriate data by combining quantitative and qualitative methods.

Statistical analysis and numerical data are essential components of quantitative research (Gall and Borg 2002). Nevertheless, qualitative research relies on written data and subjective analysis. Thus, a pragmatic approach allows the researcher to combine methods from both approaches to best answer the research question.

3.3.3. Pragmatism Paradigm:

Due to its flexibility and ability to draw on multiple workable ideas, pragmatism supports mixed methods approaches, which have gained acceptance as the "one best" worldview (Denscombe 2008). Wahyuni and Suter suggest that rather than selecting a method proactively, researchers should focus on answering the research question and use the appropriate approach according to the question (Wahyuni 2012). By employing mixed

Chapter 3: Research Design and Methodologies

methodologies in the same study, pragmatic researchers can dig deeper into a data set and verify the findings of one method with those of the other (Onwuegbuzie and Leech 2007).

According to pragmatists, research questions, not epistemological purity, should shape the research methods (Onwuegbuzie and Leech 2007; Christensen et al. 2011).

Combining various methods can lead to cumbersome findings rather than conflicting results, according to (Yvonne Feilzer 2010). The design, analysis and discussion of mixed methods research require a careful and reflexive approach, according to (Greene et al. 2001).

3.3.4. Justification of Using the Philosophical Foundations of Mixed Methods

Research

The researcher selected a positivist approach because this study utilised numerical analysis. For this study, positivism cannot provide a means of examining human perception, experience, and behaviour in depth on its own. The relationship between a building and its surroundings is tricky to understand in terms of how and why it is handled by architectural practices. Therefore, it was considered essential to generalise the findings. An innovative approach was used, which combines interviews and image sorting surveys conducted with architects.

To gain a comprehensive understanding of the situation, the researcher must become immersed in it. Thus, this research also has an interpretivist component. Data from qualitative sources can provide insight, while data from quantitative sources can aid generalisation. Therefore, the research also attempted to generalise based on the perspectives of numerous interview participants.

3.4. Methodological Approaches and Research Methods/Techniques

Research methodology, as (Kothari 2004) defines it, refers to a systematic inquiry that aims to solve a research problem. According to Crotty (1998), a research method comprises the set of procedures and strategies for collecting and analysing data (Crotty 1998). The research design focuses on planning and executing the research (Punch and Oancea 2014). According to Akšamija, research methods are mechanisms employed to evaluate the established research questions (Akšamija 2021). In terms of research methodologies, there are four common types: quantitative, qualitative, experimental, and mixed with associated techniques and methods.

Chapter 3: Research Design and Methodologies

Table 3.1: Four common types of research methodologies

	Quantitative approach	Qualitative approach	Experimental approach	Mixed-Method approach
Data collection techniques	Simulations and modelling	Archive research	Prototyping	Mix any two or three approaches of Quantitative, Qualitative and Experimental
	Quantitative surveys	Interview	Testing	
	Correlational research	Focus groups	Experiments	
		Observations		
		Case studies		

3.4.1. Quantitative Research

The quantitative approach collects factual data to determine the relationships between them. Quantitative approaches use variables and numbers measured and analysed in a statistical way (Norman and Lincoln 2000). The quantitative approach is often used in social science research to test questions or hypotheses against a list of variables (Crotty 1998; Blaikie 2003). (Akšamija, 2021) stated that quantitative research uses numerical data to explore specific research questions and test hypotheses, typically focusing on questions related to the environment, technology, economics, and the performance aspects of architecture. Employing a quantitative approach makes it possible to examine the performance of buildings and their built environment, test theories, understand people's behaviour and opinions and predict future performance. Moreover, the data analysis process for quantitative methods relies on statistical techniques rather than the researcher's data interpretation. In the quantitative approach, simulation and modelling, a quantitative survey featuring (questionnaires, structured interviews, and structured observations) and correlational research can help collect data (Saunders et al. 2007; Akšamija 2021).

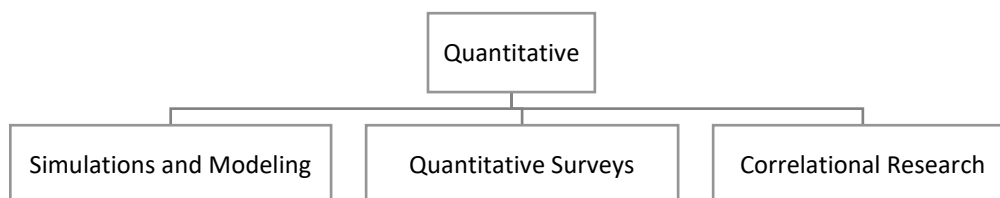

Figure 3.1: Quantitative research methods

3.4.1.1. Simulations and Modelling

A simulation models a real-world phenomenon to study its parameters, behaviour, interaction, and performance. Simulation models can be visual, mathematical, or

Chapter 3: Research Design and Methodologies

computational. Visual models represent phenomena graphically. Mathematical models represent phenomena using equations. In computational models, algorithms represent phenomena, systems and behaviour, and each type of model requires its own software programme. Energy research is a widely employed research method that uses simulation. In architectural research that uses simulations and modelling methods, the main advantage is the ability to understand and explore phenomena computationally, in turn, reducing the time and cost involved. Additionally, simulations can investigate a design decision during the design process, leading to a building's improved outcomes and performance levels. The main drawbacks of this method are the limitations of simulation tools and their uncertainty and validity (Akšamija 2021).

3.4.1.2. Quantitative Surveys

Surveys used to test scientific theories, examine relationships among variables and analyse numerical data employ statistical procedures (Kothari 2004). The technique helps researchers identify factors influencing outcomes, describe trends, attitudes, and opinions or test a theory or explanation. These types of studies have their roots in psychology (Creswell 2014) and closely align with positivism and objective measures (Suter 2014). Researchers who conduct this kind of research examine theories deductively to generalise and reproduce findings. While these surveys are useful for gathering broad information, they do not provide in-depth information. The primary research method of quantitative surveys involves the use of questionnaires to gather numeric data on a specific research topic (Akšamija, 2021). Through this approach, people's feelings, perspectives, experiences, and thoughts are numerically assessed. A researcher must first pinpoint the objective of their study and determine the specific research questions and variables they will investigate to answer the questions. Based on Aksamija (2021), the benefits of quantitative surveys include: 1) large samples of the population can be used to collect information; 2) this method can help investigate various topics; 3) numerous variables can undergo examination; and 4) with the online distribution of surveys, data collection is straightforward. However, this method may have a disadvantage because respondents' characteristics may not represent the general population, and a smaller sample size influences the results. In architectural research, qualitative and quantitative surveys are often used together to allow researchers and scientists, besides collecting numeric data, to gather qualitative information about people's perceptions, beliefs, feelings and opinions.

3.4.1.3. Correlational Research

Relationships between variables are measured in correlational research and can help clarify related events, conditions, or behaviours (Groat and Wang, 2013). This type of research method uses statistical data analysis to determine whether and to what extent a statistical relationship exists between two variables (Akšamija, 2021). One benefit of this research method is discovering new relationships between phenomena. The correlational approach, however, focuses only on the statistical relationship between variables and cannot determine cause and effect.

3.4.2. Qualitative research

Qualitative research obtains non-numerical data to answer questions about specific aspects of architecture, including social, cultural, psychological, historical, or theoretical concerns (Akšamija, 2021). Qualitative approaches, such as phenomenology, investigate, capture, and explain individuals' emotions, attitudes, thoughts, meanings and perceptions during or after a phenomenon (Suter, 2014; Groat and Wang, 2013). Typically, research is inductive since the researcher aims to establish concepts or theories through gathering data instead of deductively testing hypotheses. Qualitative research relies heavily on the researcher's ability to analyse and interpret data, so the researcher's assessment capacity is critical. The most common qualitative methods used in architectural research comprise archival research, interviews, focus groups, observation, and case studies.

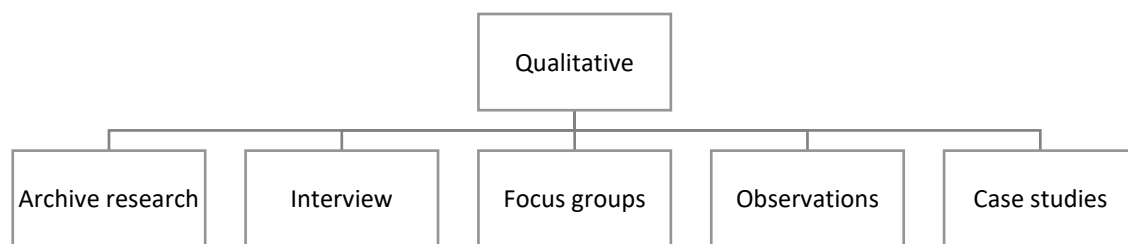

Figure 3.2: Qualitative research methods

3.4.2.1. Archival Research

Archival research involves studying major records held in archives, special collections, libraries or other repositories of documents (Akšamija, 2021). Manuscripts, documents, books, drawings, photography, newspaper articles, objects, sounds and audio-visual materials form part of archival sources.

Archiving data represents an effective tactic that helps put an existing database to effective use and aid further research in the future. An example of this tactic was used in Newman's

Chapter 3: Research Design and Methodologies

study to explain the Housing Authority's measurement of the wealth of demographic variables, which included data on age, income, years of residence, previous background and history of family pathology (Groat and Wang, 2013). According to Newman, using this data made it possible to locate the most dangerous areas, in addition to comparing crime rates in the different types of buildings and project layouts (Newman 1972). Conducting archiving research, both digitally and physically, involves analysing archived documents, drawing conclusions from the evidence, and interpreting the results. The advantage of this approach in architectural research is the use of primary sources. However, as with any qualitative research method, the results rely on the researcher's interpretation, and the data might be missing or incomplete.

3.4.2.2. Interviews

The interview method aims to explore and understand opinions, preferences, experiences, attitudes, behaviour, feelings, and phenomena. Researchers must determine the number of interviewees, their characteristics, how they will be selected and the primary method they will use to collect data during the interview. Interviews are usually of three types: structured, unstructured, and semi-structured. According to (Bryman 2012), the structured interview is a type of quantitative research; however, the unstructured and semi-structured interview are two types of qualitative research.

1. **Structured interview:** Also known as the 'standardised interview'. In this kind of interview, the questions usually vary and offer the interviewee a fixed range of answers. These questions comprise closed, closed-ended, or fixed choice types.
2. **Semi-structured interview:** This type of interview provides more space for the reviewer to ask a general question; the reviewer can also ask a follow-up question.
3. **Unstructured interview:** The interviewer only covers topics in the interview guide; the question style is usually informal.

Chapter 3: Research Design and Methodologies

Table 3.2: Differences between the structured interview and qualitative interview (Researcher after Bryman, 2016)

Structured interview	Qualitative interview (Unstructured, Semi-Structured Interview)
The approach is structured.	The approach tends to be less structured.
Cannot depart from the questions, or it will compromise the data's reliability and validity.	Can depart from the guide, like asking a follow-up question.
Reflects the research concern.	Interest in the interviewee's point of view.
Inflexible because of the need for standardised questions.	Tends to be flexible by going in the direction in which the interviewee takes the interview.
The participant will be interviewed on one occasion only.	Interviews might take place more than one time.
The interview needs a detailed answer.	The interview answer needs to be coded and processed.

According to (Bryman, 2016), distinguished types of purposive interview sampling approaches have been identified by (Patton, 1990) and (Palys, 2008):

- Extreme or deviant case sampling: Cases are unusual and are distant to a specific dimension of interest.
- Typical case sampling: Cases are typical because they exemplify a dimension of interest.
- Critical case sampling: Sampling a crucial case may lead to a logical inference about the phenomenon of interest.
- Maximum variation sampling: Cases are varied to maintain a different dimension of interest.
- Criterion sampling: Targeting all units (cases or individuals) that meet a certain criterion.
- Theoretical sampling: The process of data collection which can undergo analysis to generate a theory.
- Snowball sampling: Studies sensitive areas, which can involve a range of people in a covert issue.
- Opportunistic sampling: Uses the sampling cases as opportunities to collect data, which may contact individuals not in the field of study but may provide data that applies to the research question.
- Sampling in a mixed-method approach: In mixed qualitative and quantitative methods, in some cases, the findings from a survey could act as the source for the selection of a purposive sample.

Interviewing offers the advantage of exploring different aspects of research topics in architecture. The limitation of such an approach is the limited size of participants due to cost and time constraints. The limited numbers of participants also affect the generalisation of the

Chapter 3: Research Design and Methodologies

results. Moreover, an essential consideration of using interviews is that the participants' selection might influence research results.

3.4.2.3. Focus Groups

Focus groups and interviews are fundamentally different because focus groups tend to take place collectively, while interviews are mostly conducted individually (Aksamija, 2021). Moreover, in focus groups, the researcher moderates the participants, who discuss their interests in the topic. Similarly, in interviews, focus groups involve structured discussions designed to gather qualitative data from a group of people. The advantage of using focus groups is that they can provide perceptions on different topics and views. The data can also be collected more quickly and at less cost than an individual interview. However, the drawback of this method is that it creates difficulties drawing conclusions due to the limited number of participants (Masadeh and Masadeh 2012).

3.4.2.4. Observations

Observations, as the primary method of collecting data, rely on noting certain phenomena. The assessments primarily focus on social and behavioural research to understand space use, the interaction between people and the built environment and the environment's physical attributes (Zeisel 2006). Observation can be structured or unstructured. Structured observation focuses on a small number of variables and follows a predefined process for gathering data, whereas unstructured observation collects data organically. Direct observation of physical phenomena and human behaviour is one of the advantages of observation. Nevertheless, it is a time-consuming process that can struggle to observe large numbers of people simultaneously (Aksamija, 2021).

3.4.2.5. Case Studies

Applied case study research focuses on specific research questions within the boundaries of a particular environment, group, building type or building type and in real-life settings. A single case study allows exploration of one subject in detail or can facilitate multiple case studies to compare phenomena according to predetermined research objectives and questions. An advantage of case studies is that they can help gather detailed information and easily integrate with other research methods. Despite this, the case study approach is tricky to replicate, and some cases cannot be generalised (Groat and Wang, 2013).

3.4.3. Experimental Research

This study employs experimental methods to investigate the effect of manipulating independent variables on a dependent variable. Researchers control and measure variables in experimental research and manipulate one or more variables to investigate physical, real-world phenomena. Experimental methods can take place in the field or laboratory settings. While the researcher has more control over the research process and setup in the laboratory, experimental research in the field uses real-world settings. In such an approach, prototyping, testing, and experiments are common types used for data collection (Aksamija, 2021).

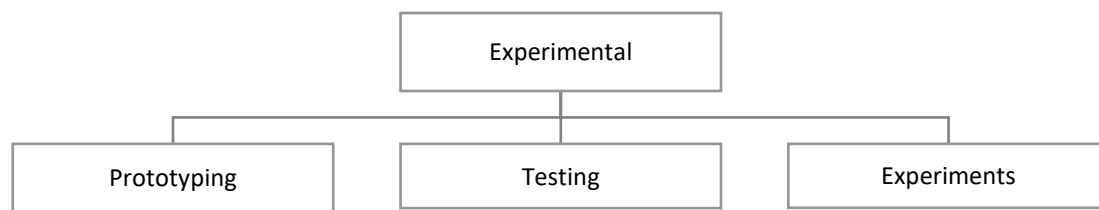

Figure 3.3: Experimental research methods

3.4.3.1. Prototyping

A prototype is a physical model or digital model scaled up or on a real scale to investigate research questions. In prototyping, ideas, assumptions and design approaches undergo testing to validate them before their full implementation in architectural design. Prototyping can be either iterative or parallel (Camburn et al. 2017). Iterative prototyping improves characteristics, performance, and outcomes by gradually refining prototypes. However, parallel prototyping examines multiple prototypes concurrently and enables comparative evaluations. Digital fabrication and computer-aided manufacturing have become more widely used for prototyping (Aksamija 2017). Furthermore, these methods can help evaluate construction, material properties, form, and geometry properties. Researchers can generate multiple prototypes and iterate on design approaches by combining computational design tools and prototyping techniques. The benefits of prototyping include design approaches that can be evaluated before implementation in a building, and prototyping provides flexibility and refinement opportunities. Moreover, the prototyping approaches can combine with other methods, such as testing. The limitation of prototyping is the limited number of possible iterations due to cost and time constraints.

3.4.3.2. Testing

Testing represents a method of evaluating the characteristics of a product, process or phenomenon in accordance with specific guidelines. A physical mock-up is required for testing

Chapter 3: Research Design and Methodologies

materials, products, and systems. In software development, for instance, user evaluations are often used for testing purposes. There are several disadvantages associated with this method, including high costs, the need for test equipment and space and physical prototypes or mock-ups (Aksamija 2021).

3.4.3.3. Experiments

Experimental studies are systematic methods for testing hypotheses, discovering unknown facts or determining causal relationships among variables under controlled conditions. Experiments in architecture examine people's reactions to a design outcome or design process, building performance, energy consumption and building physics. Additionally, experiments can evaluate new building technologies, digital technologies, design processes, products and systems and evaluate design outcomes (Aksamija 2021). In experimental research, graphical representations of the results, such as diagrams, charts, graphs and tables, are essential. A major advantage of using experimental studies is the ability to replicate the experimental setup and results. However, this time-consuming and costly process may encounter difficulties generalising the findings from different scenarios.

3.4.4. Mixed-Method Approach

Mixing qualitative, quantitative, and experimental research into one study or series on the same subject is known as mixed-method research. It combines the strengths of each method and neutralises its weaknesses. Thus, mixed-method research serves as a middle ground that helps researchers fully understand the research problem (Creswell 2014). Mixed-method research combines two or more approaches to address a specific research problem, and its main benefit involves an improved understanding of the problem. Different data collection mechanisms and analysis approaches can analyse the research problem from different perspectives (Aksamija 2021). According to Kumar (2014), such an approach improves the results' qualitative and quantitative validity, significance, accuracy and meaning. For a study with multiple objectives, he recommended a mixed-method study design and generalising and sharing findings with the study population. Creswell (2014) described three different integrations of the mixed-method approach:

1. Using the quantitative approach first, the obtained results will investigate the research problem further. In this manner, quantitative methods will lead to qualitative ones; thus, it has an explanation sequence.
2. The qualitative approach will explore the participants' viewpoints, and a quantitative approach will investigate the research problem further. In this manner, the

Chapter 3: Research Design and Methodologies

qualitative methods will lead to the quantitative ones; thus, it is an exploratory sequence.

- Solving the research problem by combining results from the two approaches (qualitative and quantitative). To allow a comparison of the two approaches, data underwent separate collection. Therefore, contradictions or similarities would become apparent, meaning it follows a parallel logic.

According to a variety of scholars, applying a mixed-method approach presents several benefits and advantages (Alexander et al. 2016; Kumar 2014; Bryman 2016; Creswell 2014, Aksamija 2021). Collecting the data from different resources will help fill the research gap more accurately than one resource, which will lead to increased levels of results confidence. Due to the use of various techniques, tools and software during the data collection and analysis phases, this type of research also requires various skills and more time and financial resources to handle the different stages (Kumar 2014).

Table 3.3: Qualitative, quantitative, and mixed-method approaches (Adopted by the author from (Creswell, 2014; Bryman, 2016; Kumar, 2019))

Tend to	Qualitative approach	Quantitative approach	Mixed-method approach
Use these philosophical assumptions	Constructivist, Advocacy, Participatory knowledge claims	Postpositivist knowledge claims	Pragmatic knowledge claims
Employ these strategies of inquiry	Phenomenology, Ground theory, Ethnography, Case study and narrative	Surveys and experiments	Sequential, concurrent and transformative
Employ these methods	Open-ended questions, Emerging approach, Text, or image data	Closed-ended questions, Predetermined approach, Numeric data	Both open and closed-ended questions, Both emerging and predetermined approaches, Both qualitative and quantitative data and analysis
Use these practices of research as the researcher	Positions him or herself, Collects participant meanings, Focuses on a single concept or phenomenon, Bring personal values into the study, Studies the context or setting of participants, Validates the accuracy of findings, Makes interpretations of data, Creates an agenda for change or reform, Collaborates with the participants	Tests or verifies theories or explanations, Identifies variables to study, Relates variables in questions or hypotheses, Uses standards of validity and reliability, Observes and measures information numerically, Uses unbiased approaches, Employs statistical procedures	Collects both Qualitative and Quantitative data, Develops a rationale for mixing, Integrates the data at different stages of inquiry

3.4.5. Justification of Using the Mixed-Method Approach in the Research

In the research field, varied issues affect the choice of the best methodological approach: reliability, validity and practicality (Haralambos and Holborn 1995; Kumar, 2014).

- a. Reliability: Kumar defined reliability as "consistent and stable, hence predictable and accurate" (Kumar 2019). Meanwhile, Bryman argued that the methods could prove reliable if they show suitability for the time and other researchers produce the same results with similar material and data (Bryman 2016). In the main, quantitative methods provide higher reliability than qualitative methods, as quantitative methods produce data in a statistical form, and the qualitative methods mean the participant can interpret questions differently from other respondents (Haralambos and Holborn, 1995).
- b. Validity: A valid method is defined as accurate reflection and an image of what is being studied or measured. Therefore, interviews or observations, a qualitative methods technique, provide a more accurate picture than the quantitative methods, which may not give the reflect the same view (Haralambos and Holborn 1995).
- c. Practicality: Quantitative methods require less time and less personal consumption. However, carrying out qualitative studies means the researcher wants to see more details and delve into a smaller sample (Haralambos and Holborn 1995). Meanwhile, the quantitative method can give a comprehensive picture of the issue, as it represents a vital representative sample.

The different techniques in a study might be combined or integrated when different methods are used. When combining different methods, one receives higher priority than the other, and the researcher requires additional techniques to provide a complete picture (Alexander 1964; Gilbert and Stoneman 2015). In this research, the data collected could be limited. Therefore, the researcher used an archive method to collect more information. According to the archive method, a survey of image sorting was conducted to cluster images of building and ground relationships. Additionally, a qualitative interview was conducted to validate the taxonomy and problem of building and ground. Furthermore, the researcher generates a dataset using a computational method. A second computational method of machine learning was utilised to cluster and categorise the building and ground relationships.

3.5. Research Framework

The steps in a research process should be clarified at the beginning (Kumar, 2019). Following the formulation of a research problem and research design, researchers need to develop instruments for collecting, analysing, interpreting, and evaluating data.

3.5.1. Formulating the Research Problem

According to the literature review about the different approaches to the building and ground relationship (Berlanda, 2014; Hensel and Turko, 2015; Porter, 2015, 2017, 2018), and to enable architects to make informed design decisions regarding the building and ground relationship, digital aids must help them identify building and ground relationship characteristics in the early design stages. Manually performing this task can prove costly, time-consuming, and prone to errors. In the age of AI and especially graph-based machine learning, designers can predict the buildings and the ground relationship during the design process because of automatic classification. This framework has the potential to introduce into the design process similar precedents such that the designer can quickly estimate the performance consequences of their design decisions. Therefore, the study aims to contribute to this area and presents to the practitioner the importance of taking into consideration the building's ground at the earliest possible design stages before the complexity and rigidity of a fully developed BIM model take hold.

The study sought to develop a computational model for the design of the buildings with taking the ground into consideration in the earlier design stage. Moreover, it sought to find a mechanism for encoding an abstracted 3D model using a computational model. The following comprise the main areas of investigation:

- What is the building and ground relationship taxonomy?
- How could we measure and code the formal relationship between the building and the ground into geometrical and topological parameters?
- How could machine learning models be developed that classify and cluster the building and ground relationship?
- How could a flexible computational tool be developed that guides the designer to take the ground into consideration and help them retrieve a similar precedent?

3.5.2. Conceptualising the Research Design

Following a systematic process and following a set of steps that are oriented toward a specific result, architects are able to identify building parameters that reflect specific characteristics

Chapter 3: Research Design and Methodologies

of the relationship, which facilitates the development of computational models and provides the greatest benefit to the researcher.

One approach to dealing with the problem involves drawing inspiration from historical and contemporary precedents. However, to date, AI techniques have focused on 2D visual image-based representations of building features to classify buildings (Shalunts, Gayane, Yll Haxhimusa 2011; Shalunts 2012; Shalunts et al. 2012; Lee and Lee 2016a; Huang and Zheng 2018). Making use of only pixel information reduces the system's ability to use 3D information. On the other hand, encoding an abstracted 3D model is tricky and too time-consuming for machine learning. Therefore, because of topological graphs, 2D pixel representations are no longer constrained by their limitations and do not necessitate the complexity of encoding an abstracted 3D model. Thus, the challenge shifts to deriving topological graphs from a conceptual abstracted model.

A cross-sectional study obtained a more complete picture of the relationship between the building and the ground. To establish a database for the design of the relationship between the buildings and their grounds, the following sources were utilised:

1. Analysing documents by examining books, reports and scholarly studies that address aspects of building and ground relationships.
2. Archiving historical and contemporary architectural precedents into databases for use in the retrieval stage.
3. An image sorting survey to examine the similarity and performance of human image recognition of the building and ground relationship.
4. An in-depth interview with architects to understand their philosophies in building and ground issues and to validate the building and ground taxonomy.

3.6. Research Design

According to Kumar (2014), the research design is about "the plan, structure, and strategy of investigation to find answers to research questions as validly, objectively, accurately, and economically as possible" (Kumar 2014, p. 122). Colin Robson (2002) defined the research design as a process that helps transform the research question into a research project (Robson 2002). Moreover, Gray (2014) stated that research design is "the overarching plan for the collection, measurement and analysis of data"(Gray 2014, p. 31). According to these definitions, this section addresses the workflow implemented in this research and how the data will be collected, coded and analysed to find the best solution to enable the architect to

Chapter 3: Research Design and Methodologies

learn from the historical precedent of the building and ground relationship. The researcher adopted different methods, presented in the following phases and stages.

Table 3.4: Phases of studies and Research Methods

Phases of the study	In which chapter the phase is presented
Phase (1): Data collection	Chapter Four (Part A)
Phase (2): Data analysis	Chapter Four (Part A)
Phase (3): Grammar construction	Chapter Four (Part B)
Phase (4): The generation of 3D prototypes of building and ground architectural precedents	Chapter Four (Part B)
Phase (5): Machine learning models to cluster and classify the building and ground relationship	Chapter Five (Parts A and B)
Phase (6): Tool for retrieving similar architecture precedents	Chapter Six (Part A)
Phase (7): System Usability Scale (SUS) of using the proposed workflow of the building and ground relationship	Chapter Six (Part B)

3.6.1. Phases of Studies and Research Methods

Phase (1): Data Collection

The data collection stage aims to define the current characteristics of the building and ground relationship. It also sought to study how the architects consider the ground and building relationship. The approach used to collect the data is the quantitative method, such as sorting workshop images to classify the building and ground relationship. The research also assessed qualitative archiving data and utilised interviews to collect architectural viewpoints relating to the building and ground relationship, validate the building and ground relationship taxonomy and discuss the usefulness of using the computational tools to cover this relationship.

Stage 1. Archives Data

Studying several historical cases and examples of contemporary building could provide evidence about specific building and ground relationship themes. These themes could create a building and ground relationship taxonomy. Such a method, which does not require participants, needs effort from the researcher to know where and how to look (Groat and Wang, 2013). This effort can focus on looking at more building cases and then analysing the sectional drawing building, specifically the ground line of these sectional drawings, which could generate concepts of how the building meets the ground.

Chapter 3: Research Design and Methodologies

At this stage, more than 500 architectural precedents were collected. These precedents were focused on a period of the last decade and sorted in a database program (Microsoft Access Database Software).

A random sample of significant architectural precedents was recruited from a period from the 19th century to the present. These 100 years were divided into three considerable periods of architecture: modern, postmodern, and contemporary. The implemented criteria for selecting the architecture precedents comprised:

1. Architectural time precedents, meaning all the case studies collected fall between 1900 and the present.
2. Some of the structure, landscape and urban projects were collected in this study. However, the focus was on buildings.
3. The architectural precedents were collected from two primary architecture domains, namely residential buildings, and public buildings.
4. The collected cases have a clear perspectival image that shows the relationship between the building and the ground.
5. The buildings collected were either existing or built and then demolished. A few unbuilt building designs or imaginarily concepts were used only for explaining unique relationships between the building and the ground.

The architect's name, building name, building stats, building type, the construction or design years, the building location (continent, country and city) and the period of architecture history were collected for each case study. The most important data archived with each case study presented a clear image of how the building can meet the ground. All the data, comprising 'text' and 'images', were inserted into the Access manual.

Stage 2. Interview with Architect Experts

This study aims to develop an architect design computational method of clustering and classifying the building and ground relationship, making it useful to engage with the architects through face-to-face interviews to collect their philosophies and points of view in the study area. The research interview is a noted data-collection strategy in qualitative and quantitative research methods.

In the interviews, the researcher aimed to ask the interviewee about the building and ground relationship problem in relation to architectural design. The interview sought to pinpoint related challenges facing architectural practice during the early design stage and evaluate the building and ground relationship taxonomy, content, and visual appearance. The research also

Chapter 3: Research Design and Methodologies

aimed to uncover the need for and benefit of introducing a computational design tool that can cluster and classify the building and ground relationship. The interview contained 17 questions divided into four sections. The interview's semi-structured nature allowed it to utilise more questions to facilitate further exploration of the topic. Answers to the interview questions can be verbal or make use of images to aid explanations. The interview was designed to take between 50 and 60 minutes. Participation in the interview was limited to architects with more than ten years of experience in building and ground relationships in academic or practical environments.

The interview questions were formulated as follows:

1. Indicate the research area: The research area is to explore the architectural design for the building and ground relationship and validate the building and ground relationship taxonomy. The aim is also to get an expert point of view on the importance of classifying and clustering the building and ground relationship using the architecture computational method.
2. Specify research questions: To facilitate the process of coding the results, a semi-structured interview with experts' architect was adapted to answer the following questions:
 - What are the issues and challenges that face the architect when he designs the building on the ground?
 - How can the building and ground relationship taxonomy help reduce these issues?
 - How can the computational methods achieve these goals of helping the architect spatially in the early stage of design?
3. Different kinds of questions: In this interview, we used a different set of questions for different reasons.
 - Introducing questions: (e.g., Please tell me about...) to introduce a topic.
 - Follow-up questions: (e.g., What do you mean by...) to elaborate his or her answer.
 - Probing questions: (e.g., In what ways do you find this, could you explain more about...) to delve further into a point.
 - Specifying question: (e.g., Where would you like to move to? What did you do then?) to provide a specific answer, such as the location or process.
 - Direct questions: (e.g., Do you find it easy to have...? Are you happy with this...?), perhaps best left until the end of the interview.
 - Indirect questions.

Chapter 3: Research Design and Methodologies

- Structuring questions: To organise the interview (e.g., OK, now I would like to move on to a different section or topic).
- Silence to give the interviewee the opportunity to add or clarify his or her answer.
- Interpreting questions: The interviewer 'sought to verify her interpretations during the course of each interview by offering tentative summaries and inviting participants to challenge or confirm her understanding' (Bosley 2009).

a. Interview Sampling Size:

One of the challenges of qualitative research is that it can be difficult to know how many interviews are needed to reach theoretical saturation. However, according to (Corbin 2015), the research can evaluate the saturation by looking at the interviewees' answers. It is determined by examining the interview answers for each question and determining whether the answers are repeated by a significant number of interviewees. This indicates that theoretical saturation has been reached. Therefore, the researcher examined the interview answers for each question after the fifth interviewer. As a result of the researcher's analysis, the answers were found to be repetitive, which indicates that theoretical saturation has been reached.

b. Translating the Interview:

The interview took place in the preferred language of the interviewee (Arabic or English). In cases where interviewees preferred to answer the questions in Arabic, the researcher recorded the answer and translated it to English before the coding process began.

c. Interview Pilot Study:

During this study, the researcher conducted three interviews to test the interview questions (pilot study) to receive their feedback on the questions' content. Pilot studies test instruments of data collection (Naoum 2012). Performing a pilot test ensures that respondents will not have any difficulty answering the questions after it has undergone testing, and thus, it can be used for a full-scale survey (Bell et al. 2022). Additionally, Robson (2011b) recommended that the first step in any data collection should be a pilot study. Performing pilot tests in this manner will allow the researcher to make changes and adjustments to the proposed study (Saunders et al., 2012). In the pilot study, all three participants were colleagues with experience in conducting qualitative interviews. They were invited to share any comments regarding issues, such as the clarity of questions, instructions and wording. Considering the interview is a qualitative method, the number of pilot participants is not crucial, but instead provides data that enables corrections to the interview questions.

d. Interview Ethical Considerations:

The interview, as part of the research process, was carried out in line with the codes of ethics applied by the research body. An ethical approval form was submitted to the Ethics Committee in the Welsh School of Architecture at Cardiff University, and approval was obtained⁽⁷⁾. Additionally, all participants were knowledgeable about the purpose of the study, including how they were expected to take part in it, what happens to the information in the project, how much time the study was expected to take, that any identifying information (e.g., names, locations) would be removed from the final transcript used for analysis and their right not to answer any question or to withdraw from the study at any time.

Stage 3. Image Sorting Survey

Since the precedent study was collected and archived in the previous stage, the image sorting workshop has been adapted to cluster the building and ground relationship into a group. Since the 1950s, classification by sorting objects into groups has been used in an assortment of cognitive and social sciences. In 1935, Hulin and Katz published a paper in which they described a facial expression using a sorting image tactic (Hulin and Katz 1935). This method of data collection has different names with the common terms being "sorting", also known as "own categories" (Sherif and Sherif 1967), "pile-sort" in cognitive anthropology (Weller and Romney 1988; Trotter 1992), and "clustering" (Fillenbaum and Rapoport 1974). Moreover, mathematicians and statisticians indicate the rustle classification as a "partition" (Arabie and Boorman 1973; Day 1981).

Sorting techniques involve asking a respondent to sort items into groups. The items can be objects, pictures or cards. The noteworthy thing about using a sorting technique is to find out how much agreement and disagreement there is in the task. According to Rugg, sorting techniques are useful for identifying the relevant classification and investigating the commonalities and differences between specialists in the use of this classification (Rugg and McGeorge 2005). Expert participants receive a set of images to classify into different groups. According to (Morente-Molinera et al. 2019), card image sorting can have two different purposes:

- 1) Studying how an expert classifies a specific set of objects: By classifying the objects, it is possible to determine how they think or feel about the sorted topic. Examples of this tactic can be found in (Hazlett et al. 2015) and (Robinson et al. 2016).

⁽⁷⁾ See (Appendix II: The interview ethical approval forms)

Chapter 3: Research Design and Methodologies

- 2) Helping researchers conduct a complex classification: Sorting card images is a convenient way for an expert to classify a certain number of images into a specific group, helping the researcher cluster a complex task (Morente-Molinera et al., 2019).

Image sorts are restricted, the respondents only use visual information, and it is more practical than other kinds of sorting. The advantage of image sorting is that the image can provide more information to the participant, which makes the sorting more accurate. It also helps trim out the unneeded data from the image. It is possible to use the same image for different responses and workshops.

The survey was divided into two different smaller survey as follows:

- The first image sorting survey, clusters the architecture precedents into "Main Building and Ground relationships", which are **Adherence**, **Separation**, and **Interlock**.
- The second image sorting survey, clusters the architecture precedents into "Building Meet the Ground", which are **Grounded**, **Ungrounded**, **Foundation**, **Plinth**, **Artificial Ground** and **Absence of level**.

In each workshop, all the 270 architecture precedents were be given to architect experts to cluster them into the above categories.

a. The Design of the Image Survey

The workshops were start by welcoming the participant and then asking a question to specify the participant's career as one of four different categories: undergraduate student, graduate student (Master or PhD.), architectural academic staff (lecturer or reader or professor) or architectural practitioner. In case the participant was a non-architect, they were receiving a message eliminating them from the workshop, which reads "Thank you. You are not qualified to do this sorting workshop. We are focusing this study on issues, and on this occasion, you do not meet the research qualifications. We sincerely thank you and appreciate your time, dedication and continued participation in our online studies." The next step involves a participant information sheet, including a brief of the study, the purpose of this investigation, what the participants will do in the project and the consent form. After that, a brief description of each relationship was be defined with a sectional diagram illustration.

1. In the first image sorting workshop, the participants were receiving the following definition and sectional diagram illustration (Figure 3.4).

Chapter 3: Research Design and Methodologies

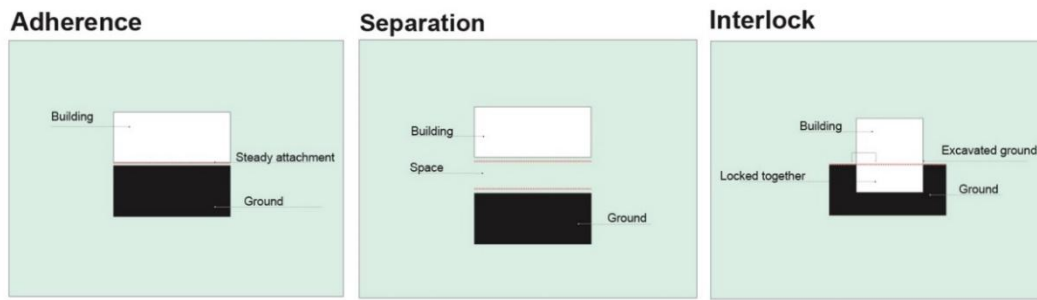

Figure 3.4: Main building and ground relationships

- Adherence: Defined in relation to buildings that stick to the ground or are laid like a carpet on the terrain. Moreover, this relates to using light consolidations or thin platforms to serve as an artificial groundwork that traces the building's contour lines (Berlanda, 2014).
 - Separation: Defined as lifting the building from the ground (on punctual supports) or limiting the links with the ground into a series of points (Berlanda, 2014).
 - Interlock: Defined as "becoming locked together or interconnected". Interlock means a configuration of the ground with the construction while sharing a space completely that complements each other (Berlanda, 2014).
2. In the second image sorting workshop, the participant will receive the following definition and sectional diagram illustration (Figure 3.5).

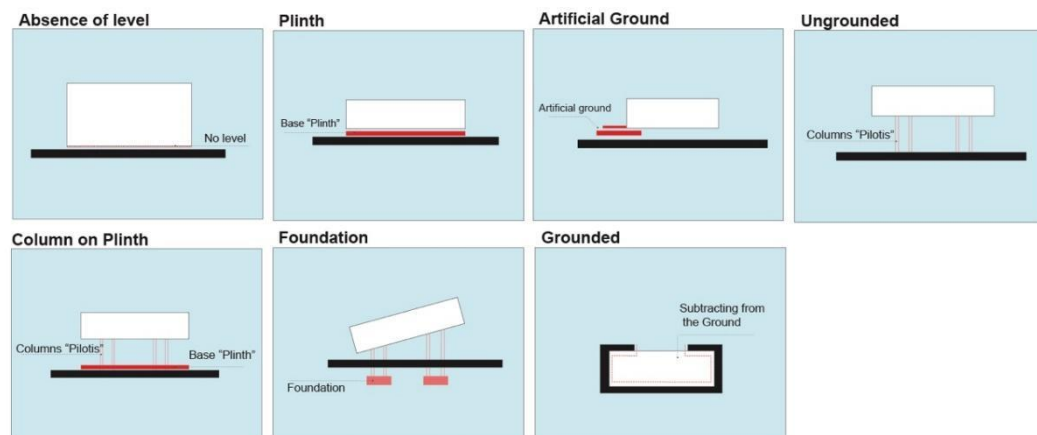

Figure 3.5: Building Meet the Ground

- Grounded: "To ground" is an English verb used to define the connection between the building and the ground; this connection can be the immersion of the building underground.

Chapter 3: Research Design and Methodologies

- Ungrounded: "Ungrounded" refers to the building that detaches from the earth and has no relations with the specific location, meaning it can be replicated anywhere, regardless of location (Rajchman 2000).
- Foundation: The meaning of "Foundation", as a singular noun, refers to building elements that make a way through terrain to reach steady layers in order to transmit the building loads (Deplazes 2005).
- Plinth: This is a portion of the earth's crust that has a dissimilar thickness, which assists as a base of the building (Wright, 1973). Comparatively, a clod is a portion or mass of earth, while a plinth is a layer with different consistency, which acts as a base of the building (Berlanda, 2014).
- Artificial Ground: The artificial ground is a thin human-made ground designed to raise the building from the ground. "We are not touching the ground, the earth we are building on is artificial; it is made from us" (Arets et al. 2002, p. 119).
- Absence of Level: This can be described as the absence of different levels between the building and the ground. The building is set directly on the ground without lifting or penetrating the building onto the earth.

At the next step, a sorting image were displayed to the participant with 30 architectural precedents on the left side of the screen and all building and ground relationship categories on the top of the right side of the screen. The participant can then drag and drop the architectural precedents to the best estimate of what the participant thinks the relationship is. The participant can also see the image on a larger scale by clicking on the magnifier tools. An example of the workshop environment, see (Figure 3.6).

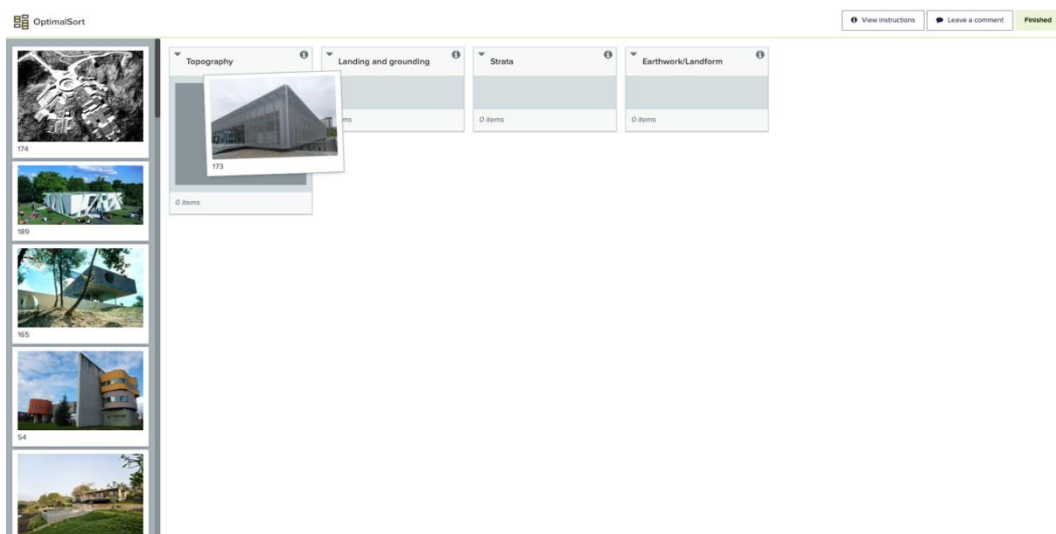

Figure 3.6: An example of the workshop environment

b. Image Sorting Survey Pilot Study

The survey should be validated and tested before publishing it to the collected data. A professionals and colleagues were asked to pre-test the draft questionnaire. The aim is to avoid any unclarity in the software used, the definition and the diagram of the building and ground relationship. The research process involved sending the survey to 15 architects to test the accuracy of the images, the clarity of the definition and the software used (pilot study). Based on the recommendations of (Isaac and Michael 1995), the number was selected. They recommended the sample size should range from 10 to 30, while van Belle (2002) recommended that the sample size should not amount to less than 12.

c. Image Sorting Survey Ethical Considerations

By forming part of the research ethics, the image sorting workshop involved the codes of ethics applied by the research body. An ethical approval form was submitted to Ethics Committee in the Welsh School of Architecture at Cardiff University, and approval was obtained⁽⁸⁾. Additionally, all participants were knowledgeable about the purpose of the study. They knew how they were expected to take part, what happens to the information in the project, how much time the study was expected to take, that any identifying information (e.g., names, locations) would be removed from the final transcript used for analysis and their right not to answer any question or withdraw from the study.

d. The Sample of Image Sorting Survey

According to Bryman (2016, p. 174), the study population is "the universe of units from which the sample is to be selected". For this research, the study population includes all the architects in the world. There is no official data on how many architects there are globally. However, according to a recent article published on Architizer in 2015⁽⁹⁾ estimates range from 3.5 to 3.8 million. To collect the right sample size, the sample calculator has been used⁽¹⁰⁾. Obtaining results requires a confidence level of 90% that the real value is within 10% of the measured/surveyed value, meaning 69 measurements/surveys must be completed. Therefore, the researcher sent an online image sorting survey on different online platforms to capture the overall picture of architects globally. The responses were collected from all these platforms and analysed.

⁽⁸⁾ See (Appendix VI: Image sorting survey ethical approval forms)

⁽⁹⁾ <https://architizer.com/blog/inspiration/industry/how-many-architects-are-in-the-world>

⁽¹⁰⁾ <https://www.calculator.net/sample-size-calculator.html>

e. Software Used in the Image Sorting Survey

Researchers employed OptimalSort ⁽¹¹⁾, which allows users to conduct moderated and unmoderated card sorting online. This technology allows the researcher to collect the necessary data as required. Additionally, it only takes a short time to design and launch a study. By analysing the card sorting data, OptimalSort produces viable insights.

Phase (2): Data Analysis

The data analysis stage includes the analysis of the responses, cases, documents and textual information to explore the different building and ground relationships, and then interpretations can be made.

Stage 1. Analysis of the Collected Architectural Precedents

To begin the process of understanding the collected and coded data at a deeper level, visualising it is an effective tool. In this stage, the 500 architectural precedents will be analysed statically alongside visualised results in the form of tables, charts, and visual images. In this stage, statistical analysis uncovers the following information: period, status, and location of architectural precedents.

Stage 2. Analysis of the Interviews

After formatting the text with Microsoft Office Word, the data were analysed manually. The researcher used manual encoding because the interview sample is small and more accurate than using software, such as NVivo ⁽¹²⁾, for analysis. Before coding, some interviews were written in Arabic and then translated into English. All information was tracked using the collected recordings. Several interactive and progressive processes should be included in the analysis stage (Bazeley 2020). Nevertheless, there is no standard procedure to follow for analysing interviews, since each research project may have circumstances that differ from one another. In this research, direct quotations support the findings of all different methods of analysing interview data.

Stage 3. Analysis of the Image Sorting Survey

To develop a holistic picture of the building and ground relationship, information gathered from participants was encoded into a taxonomy parameter. This process helped categorise the relationship into groups (Bryman, 2016). Moreover, using a confusion matrix to describe the performance of the image sorting classification model helped identify the class that could

⁽¹¹⁾ <https://www.optimalworkshop.com/>

⁽¹²⁾ <https://www.qsrinternational.com/nvivo-qualitative-data-analysis-software/home>

Chapter 3: Research Design and Methodologies

potentially merge with another class. Furthermore, the confusion matrix can describe the degree of performance uncertainty amongst participants and between participants and the researcher.

Phase (3): Grammar Construction

The shape grammars (Stiny 1975), as a rule-based system for describing the topologies, proportions and formal aspects of geometries, is adapted for constructing building and ground relationships in three dimensions.

The framework for constructing the rules outlined in five stages:

- (1) Set the rules for the configuration of the ground.
- (2) Set the rules for the configuration of the plinth.
- (3) Set the rules for the configuration of the columns.
- (4) Set the rules for the configuration of the building.
- (5) Set the rules for the configuration of the core.

Moreover, specific requirements of the building and ground relationship were associated with rules. The design process must, however, take creativity of the designer and flexibility and adaptability of the design into account. Therefore, the grammar was constructed using a parametric design method that allows designers to modify parameters and rules at any time and generate alternative designs.

Phase (4): The Generation of 3D Prototypes of Building and Ground Architectural

Precedents

With the aid of the 3D CAD software Rhinoceros 3D and the parametric modelling software (Grasshopper), the relationship between the building and the ground were translated into a computational parametric tool. In this manner, it became possible to generate customised solutions with a high degree of accuracy within a short period of time.

Moreover, to generate a 3D synthetic dataset with numerous topological variations, several Grasshopper plugin tools were used:

- (1) Topologic⁽¹³⁾: To build topological cells from the geometries and implement the graph inside the cells by using topological graph ID.
- (2) GhPython⁽¹⁴⁾: To create a custom Python script.

⁽¹³⁾ <https://topologic.app>

⁽¹⁴⁾ <https://www.food4rhino.com/en/app/ghpython>

Chapter 3: Research Design and Methodologies

(3) Colibri⁽¹⁵⁾: To generate design iterations from a collection of sliders or values and to save images of each iteration.

(4) Python script (TxtWrite): To create an output result as a text file.

Phase (5): Machine Learning Models to Cluster and Classify the Building and Ground Relationship

Due to the advent of AI, a designer can now predict the relationship between the buildings and the ground during the design process. This requires the development of a ML optimised model that will help solve the problem.

The experiments were conducted on a laptop running the MacOS Catalina 10.15 operating system on an Intel Core i7 Quad-Core CPU running at 2.7GHz with 16 GB of memory. DGCNN was implemented using the Python deep learning software library PyTorch⁽¹⁶⁾.

A. Machine Learning Models to Cluster the Building and Ground Relationship

The clustering task can be achieved by implementing algorithms that differ widely in their concept and the process of deciding the output. This study used three well-known clustering algorithms: the k-means cluster algorithm, the k-modes cluster algorithm and Gaussian mixture models (GMM). The k-means and k-modes models were chosen for three reasons: (1) a general-purpose form of the problem is required; (2) similar cluster sizes; and (3) a moderate number of clusters.

Moreover, GMM was used to determine if there is any uncertainty in the assignment of individual buildings to distinct clusters. K-means can provide information regarding the assignment of individual data points to distinct clusters. On the other hand, GMM provides information on the assignment of individual data points to one or more clusters. This is achieved by representing assignments as probabilities. K-means can be seen as a case of GMM with equal expectations per component. Implementing the clustering algorithm required using the Python machine learning library scikit-learn (Pedregosa Fabian et al. 2011).

The initialisation steps of the K-means clustering algorithm can be explained as follows:

- (1) Selecting the first division with K clusters.
- (2) Generating a new division by assigning each point to its closest cluster centre.
- (3) Calculating new cluster centres (Jain and Dubes 1988).

⁽¹⁵⁾ <https://www.food4rhino.com/en/app/colibri>

⁽¹⁶⁾ <https://pytorch.org>

Chapter 3: Research Design and Methodologies

- (4) Reiterating steps (2) and (3) repeatedly until reaching a stable state, in which the data points no longer change between clusters, meaning centroids do not require any recalculation (Stasiuk and Thomsen, 2014).

However, in the GMM, each Gaussian k consists of the following parameters: μ mean, which defines its centre; Σ probability, which defines its width; and π , which defines how large the Gaussian function will be (Carrasco 2019).

B. Machine Learning Models for Classifying the Building and Ground Relationship

The researcher adopted two machine learning models at this stage of the study. The first is an end-to-end deep graph convolutional neural network (DGCNN), and the second is an unsupervised graph-level representation learning model (UGLRL). Moreover, the researcher used the Deep Graph Library model (DGL), a software library which contains implementations of many models for further testing. The purpose of using UGLRL and DGL was for external validation of the DGCNN results.

The DGCNN model is structured as follows (Figure 3.4):

1. Three graph convolution layers, each containing 32 neurons. These layers are then concatenated to form one layer.
2. The Sort-pooling layer. Prior to feeding these feature descriptors into traditional 1D convolutional and dense layers, Sort-Pooling is responsible for sorting the feature descriptors in a consistent order.
3. On top of that, several MaxPooling layers and 1D convolutional layers are added to learn local patterns on the node sequence.
4. Lastly, there is a fully connected layer followed by a SoftMax layer.

Moreover, the DGCNN has the following default parameters, most of which were maintained throughout the experiments. Below is a summary of these unmodified parameters:

- Decay parameter: The largest power of ten is smaller than the reciprocal of the squared maximum node degree.
- SortingPool k : Set such that 60% of the graphs have more than the k nodes.
- Two 1D convolutional layers. The first layer has 16 output channels with a filter size of 2 and a step size of 2. The second 1D convolutional layer has 32 output channels with a filter size of 5 and a step size of 1.
- The dense layer has 128 hidden units, followed by a SoftMax output layer.
- A dropout layer is added at the end with a dropout rate of 0.5.

Chapter 3: Research Design and Methodologies

- DGCNN uses a nonlinear hyperbolic function (\tanh) in the graph convolution layers and a rectified linear unit (ReLU) in the other layers. DGCNN does not use validation set labels for the training.
- The neural network parameters were optimised using the Adam optimiser.
- DGCNN uses a Cross-entropy to calculate the loss function.

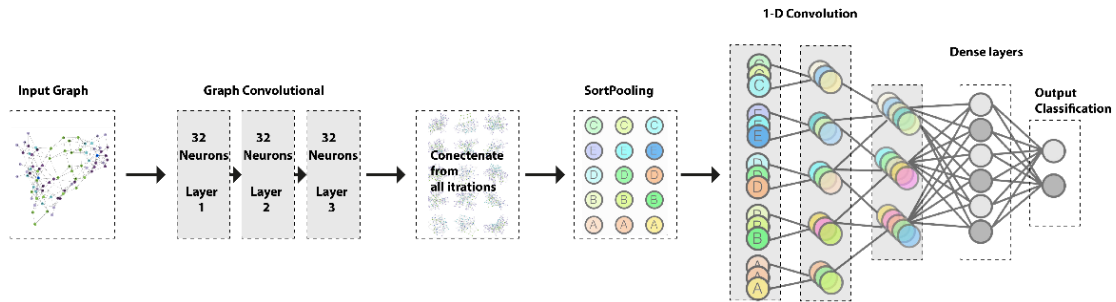

Figure 3.7: DGCNN model is structured by author after (Zhang et al. 2018)

For the Deep Graph Library model (DGL), the researcher used (Topologic DGL) blender model to examine the dataset with different ML models.

For unsupervised graph-level representation learning (UGLRL), the model process content is listed below (Figure 3.8):

1. With graph convolutions and jumping concatenation, an input graph is encoded into a feature map.
2. (Global representation, patch representation) pairs are input to the discriminator, which determines whether they belong to the same graph.
3. InfoGraph generates all possible positive and negative samples using a batch-wise fashion. For example, consider the two input graphs in the batch and seven nodes in total (above). The global representation of graph (A) will apply seven input pairs to the discriminator and graph (B). In this case, the discriminator will take 14 (global representation, patch representation) pairs as input.

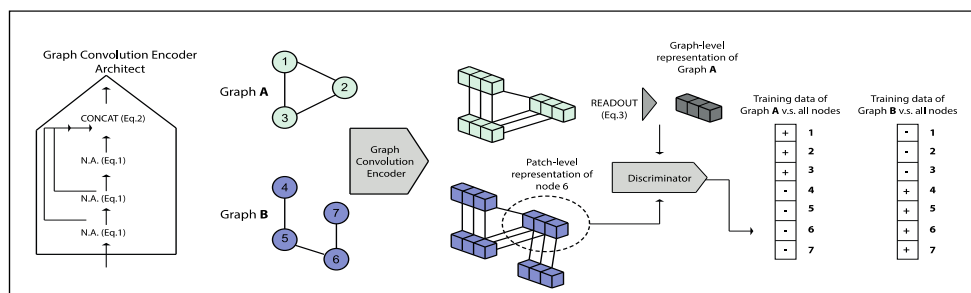

Figure 3.8: unsupervised graph-level representation learning (UGLRL) by author after (Sun et al.2020).

Phase (6): Developing a Computational Tool for Retrieving a Similar Precedent Building and Ground Relationship

The purpose of this phase is to describe the workflow (interface) of the developed computational tool utilised for retrieving a similar precedent building and ground relationship.

This phase consists of three main steps:

1. Creating the 3D architecture topological model using the created rules.
2. Implementing ML models, such as DGCNN, DGL and UGLRL.
3. Retrieving similar data from the 500 architectural precedents database.



Figure 3.9: BGR tool three three main steps

Phase (7): System Usability Scale (SUS) of Using the Proposed Workflow of the Building and Ground Relationship

To evaluate and assess the efficiency of the tool in the early stages of design, a usability questionnaire will be conducted. This questionnaire aims to assess the state-of-the-art system that helps architects classify their projects in the early design stages. This system will enable the architect to retrieve other precedents of building and ground relationships and help them reconsider the design decisions.

Using the System Usability Scale (SUS) can quickly and easily measure usability (Brooke 1995).

Using SUS has the following benefits:

1. The scale is easy to administer to participants.
2. It is possible to obtain reliable results with small sample sizes.
3. It is valid – it can effectively differentiate between usable and unusable systems.

The following summarises Suro's (2011) SUS, based on an in-depth analysis of approximately 5,000 observations (Sauro 2011) :

- "SUS is reliable". According to SUS research, users consistently respond to scale items, and SUS can detect differences at lower sample sizes than other questionnaires.
- "SUS is valid". SUS measures what it intends to measure.
- "SUS is not diagnostic". In other words, it does not explain why a system is useful or not.

Chapter 3: Research Design and Methodologies

- Despite returning a value between 0 and 100, SUS scores are not percentages. A better understanding of how a product compares to others requires looking at its percentile ranking.
- The SUS measures both usability and learnability.
- Scores on the SUS are correlated with task performance in a modest manner, and it is not surprising that subjective assessments may not show consistency with whether or not users are successful with the system. Usability assessments only comprise one element of the overall concept of usability.

a. The Design of the SUS Questionnaire:

The participant will first take part in a tutorial on using the system/tool. Evaluation exercises for the users can last between 20 minutes and an hour and end with subjective measures of the system's usability (Brooke, 1995). The ten-item questionnaire has five response options ranging from strongly agree to strongly disagree.

The responses will undergo an evaluation to measure the System Usability Scale (SUS) quickly and easily. The questionnaire has four sections:

Section one: Four questions to evaluate participants' familiarity with the used tool.

Section two: A ten-item questionnaire to measure the usability of the generative building and ground workflow.

Section three: A ten-item questionnaire to measure the usability of the Deep Graph Neural Network system.

Section four: A ten-item questionnaire to measure the whole system's usability.

In advance, the participants were informed that the questionnaire would take between 20 and 30 minutes to complete. Participants can stop the questionnaire whenever they want to take a break or finish it another time. Moreover, participants can decline to answer any questions.

b. Calculate the Usability Score Using SUS:

An overview of the method determines the SUS score. Based on their level of agreement, participants will have rated each template question on a scale from 1 to 5. On their own, individual scores do not provide meaningful information. First, sum the contribution of each item to the SUS score. Contributions ranging from 0 to 4 will be accounted for each item. In the cases of items 1, 3, 5, 7 and 9, the score contribution equals the scale position minus 1. Items 2, 4, 6, 8 and 10 contribute 5 minus the scale position. Add the sum of the scores

Chapter 3: Research Design and Methodologies

together and multiply by 2.5 to obtain the overall SUS value. These calculations have led to the final score of 100 (Brooke, 1995).

Following the adjectival rating, the results of the score calculation phases were translated into a classification of the system's usability. According to the scale bar below (Figure 3.10), a SUS score of greater than 70 is classified as an acceptable system score. Scores between 50 and 70 will be considered marginal. A score lower than 50 is considered unacceptable (Brooke 2013; Sasmito et al. 2019).

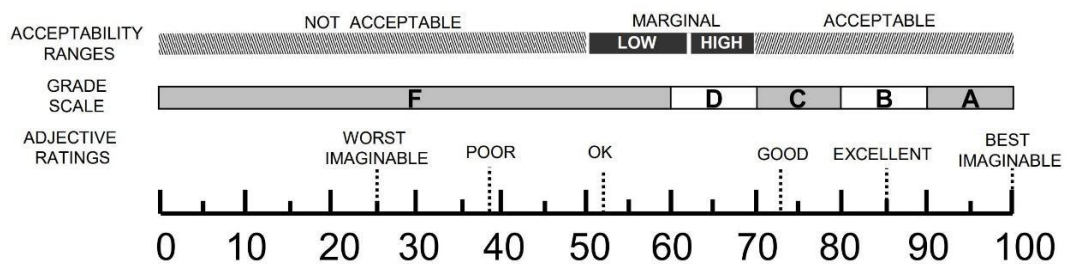

Figure 3.10: Grade rankings of SUS scores (Bangor et al. 2009)

c. SUS Sampling Size:

Tullis and Stetson (2004) suggested that using SUS to analyse a small sample of users (8-14 people) can leave the user reasonably confident that they have accurately evaluated how users perceive a given tool or system (Tullis and Stetson 2004). The chart below shows that the level of correct conclusions of the SUS can reach a level of 100% with 12 or more participants (Figure 3.11). Therefore, this SUS questionnaire sample comprised 12 participants to reach this level of correct conclusions.

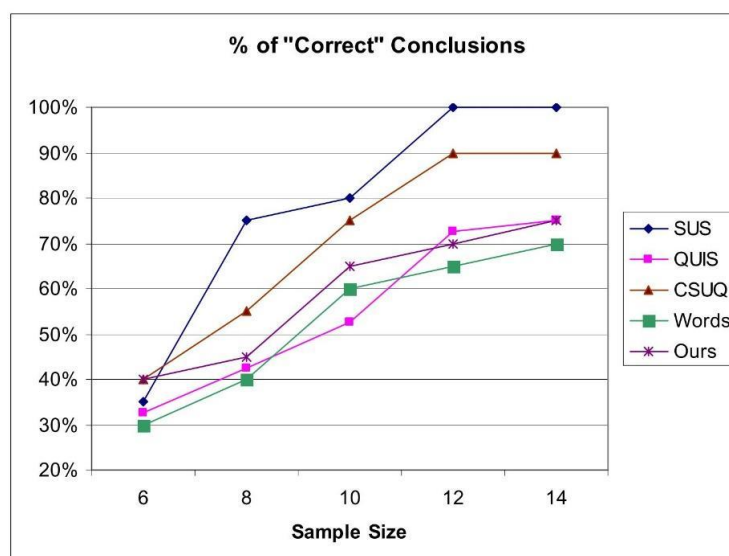

Figure 3.11: "A Comparison of Questionnaires for Assessing Website Usability" (Tullis and Stetson 2004)

System Usability Scale

© Digital Equipment Corporation, 1986.

	Strongly disagree				Strongly agree
1. I think that I would like to use this system frequently	<input type="checkbox"/>	<input type="checkbox"/>	<input type="checkbox"/>	<input type="checkbox"/>	<input type="checkbox"/>
	1	2	3	4	5
2. I found the system unnecessarily complex	<input type="checkbox"/>	<input type="checkbox"/>	<input type="checkbox"/>	<input type="checkbox"/>	<input type="checkbox"/>
	1	2	3	4	5
3. I thought the system was easy to use	<input type="checkbox"/>	<input type="checkbox"/>	<input type="checkbox"/>	<input type="checkbox"/>	<input type="checkbox"/>
	1	2	3	4	5
4. I think that I would need the support of a technical person to be able to use this system	<input type="checkbox"/>	<input type="checkbox"/>	<input type="checkbox"/>	<input type="checkbox"/>	<input type="checkbox"/>
	1	2	3	4	5
5. I found the various functions in this system were well integrated	<input type="checkbox"/>	<input type="checkbox"/>	<input type="checkbox"/>	<input type="checkbox"/>	<input type="checkbox"/>
	1	2	3	4	5
6. I thought there was too much inconsistency in this system	<input type="checkbox"/>	<input type="checkbox"/>	<input type="checkbox"/>	<input type="checkbox"/>	<input type="checkbox"/>
	1	2	3	4	5
7. I would imagine that most people would learn to use this system very quickly	<input type="checkbox"/>	<input type="checkbox"/>	<input type="checkbox"/>	<input type="checkbox"/>	<input type="checkbox"/>
	1	2	3	4	5
8. I found the system very cumbersome to use	<input type="checkbox"/>	<input type="checkbox"/>	<input type="checkbox"/>	<input type="checkbox"/>	<input type="checkbox"/>
	1	2	3	4	5
9. I felt very confident using the system	<input type="checkbox"/>	<input type="checkbox"/>	<input type="checkbox"/>	<input type="checkbox"/>	<input type="checkbox"/>
	1	2	3	4	5
10. I needed to learn a lot of things before I could get going with this system	<input type="checkbox"/>	<input type="checkbox"/>	<input type="checkbox"/>	<input type="checkbox"/>	<input type="checkbox"/>
	1	2	3	4	5

Figure 3.12: An example of SUS questionnaire

System Usability Scale

© Digital Equipment Corporation, 1986.

	Strongly disagree				Strongly agree	
1. I think that I would like to use this system frequently	□	□	□	□	√	4
	1	2	3	4	5	
2. I found the system unnecessarily complex	□	□	□	√	□	1
	1	2	3	4	5	
3. I thought the system was easy to use	□	√	□	□	□	1
	1	2	3	4	5	
4. I think that I would need the support of a technical person to be able to use this system	√	□	□	□	□	4
	1	2	3	4	5	
5. I found the various functions in this system were well integrated	□	√	□	□	□	1
	1	2	3	4	5	
6. I thought there was too much inconsistency in this system	□	□	√	□	□	2
	1	2	3	4	5	
7. I would imagine that most people would learn to use this system very quickly	□	√	□	□	□	1
	1	2	3	4	5	
8. I found the system very cumbersome to use	□	□	□	√	□	1
	1	2	3	4	5	
9. I felt very confident using the system	□	□	□	□	√	4
	1	2	3	4	5	
10. I needed to learn a lot of things before I could get going with this system	□	√	□	□	□	3
	1	2	3	4	5	

Total score = 22

SUS Score = 22 * 2.5 = 55

Figure 3.13: An example of SUS calculating the score

3.7. Chapter Summary

This chapter provides an overview of the research paradigms and theoretical approaches that have been used in this field of research. Then, a philosophical foundation for mixed methods research was reviewed in order to justify the use of philosophical grounds for mixed methods research. This chapter also gives a brief summary of the formulation and construct of this research problem in order to provide a better understanding.

As a result, a research design was developed for this thesis. The content of this research design is divided into seven phases: the collection of data, the analysis of the data, the construction of grammar, the creation of 3D prototypes of architectural precedents and the clustering and classification of these precedents using machine learning models, the development of a computational tool for retrieving a similar precedent building and ground relationship and a system usability scale (SUS) for the proposed workflow for the building and ground relationship. There was also a discussion regarding the ethical guidelines that were used in the research process.

Table 3.5: Research objective and research methods

	Research Objectives	Research Methods
1.	To identify the existing building and ground relationship	Literature search and interview
2.	To investigate the building and ground relationship	Image archiving and image sorting survey
3.	To extract and create building and ground rules	Shape grammars
4.	To generate and prototype the 3D building and ground relationship	Computational methods
5.	To classify and cluster the building and ground relationship	Machine learning model
6.	To develop a computational tool to retrieve a similar architectural precedent	Machine learning and computational methods
7.	To validate the developed computational tool	System Usability Scale

Chapter 3: Research Design and Methodologies

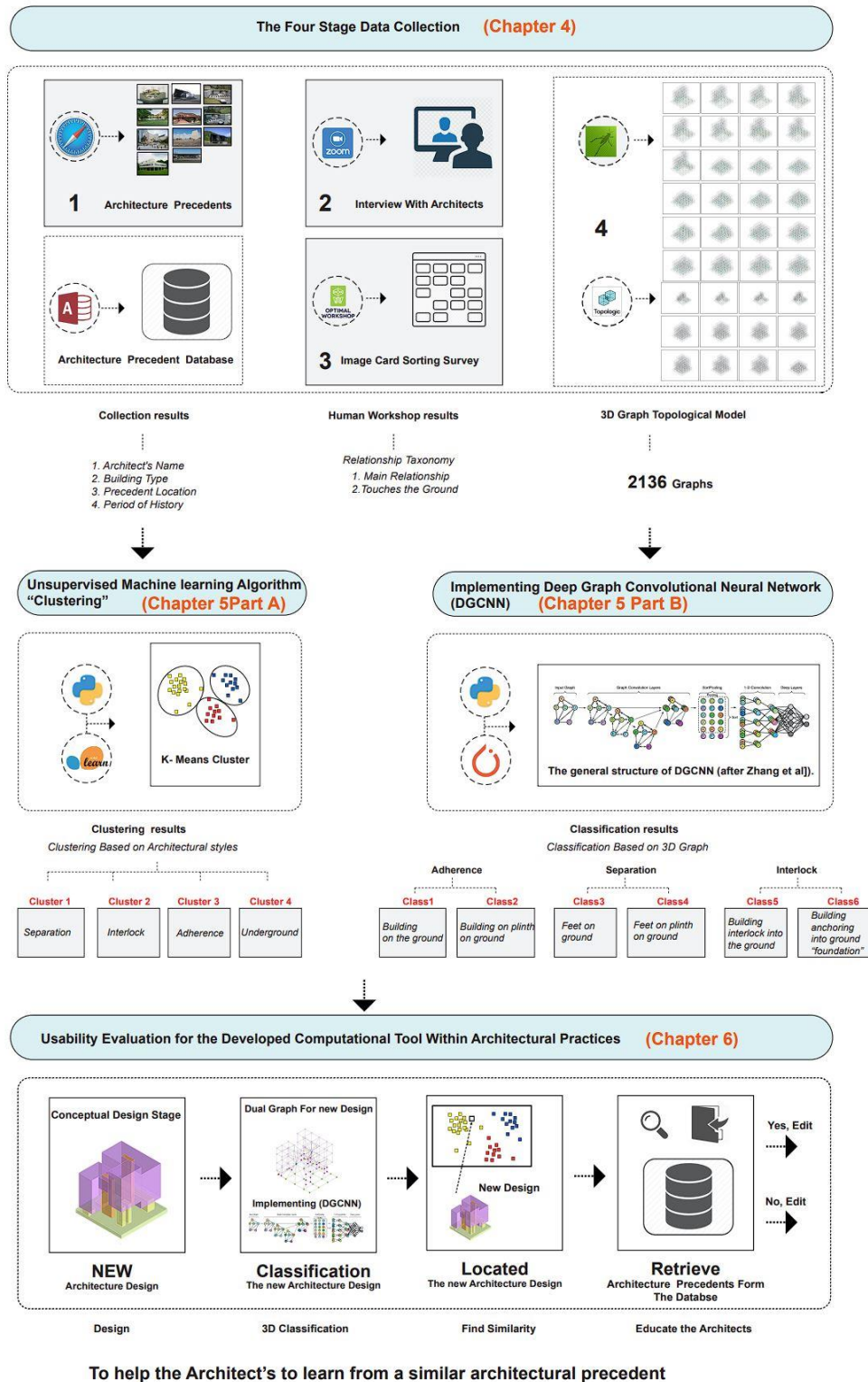

Figure 3.14: Research Design Workflow

CHAPTER FOUR

ANALYSIS AND SYNTHESIS OF BUILDING AND GROUND RELATIONSHIP

Part (A): An Investigation of Building and Ground Relationship

Part (B): Derive Prototypical Design Pattern via Architectural Precedents

Chapter 4: Analysis and Synthesis of Building and Ground Relationship

4.1. Chapter Overview

This chapter examines how architects can address the current issue in the relationship between buildings and the ground and use their knowledge to cluster this relationship. This chapter comprises two parts.

Part A starts with Section (4.2) and features an interview with architect professionals to highlight building and ground relationship challenges facing the architecture practice during the early design stage, validate the collected building and ground relationship taxonomy, and uncover the need and benefit of classifying/clustering the building and ground relationship using computational design. Then, a statistical analysis is conducted of the collected and archived building and ground relationship architecture precedents, as illustrated in Section (4.3). Such precedents help clarify the relationship between a building and its ground and can extract and translate various parameters that can feature in the design of buildings. A survey on image sorting occurred as part of Section (4.4) to determine how architects classify a specific set of images and how their answers match or do not match those of the expert (the researcher). Furthermore, the relationship between the building and the ground represents a complex task, and the image sorting survey can help the researcher to cluster the building and ground relationship.

In Part B, the study derives prototypical design patterns based on collected architectural precedents. Such a prototypical design pattern appears in Section (4.5) by extracting the rules from architectural precedents gathered in Section (4.2). The rules were constructed using George Stiny's "shape grammar" to invent systems that generate geometric shapes (Stiny and Gips 1972). Finally, in Section (4.6), generative 3D topological building and ground relationship models were generated using a visual programming language and environment referred to as Grasshopper. Moreover, the study uses Topologic, which enhances the representation of 3D models through non-manifold topology and embedded semantic information.

Part (A) An Investigation of the Building and Ground Relationship

To investigate the relationship between the building and the ground, this part presents three techniques used by the researcher. These three techniques underwent assessment in the following order: a qualitative interview with architects, followed by the collection of architectural precedents and a survey on architectural image sorting.

4.2. Interviews with Professional Architects

This section presents the interview guide used in the interview and highlights the primary architect's responses to the researcher's questions.

4.2.1. An Interview Guide with Architects to Uncover the Building and Ground Relationship

Table 4.1: The interview guide with architects

Categories	Set of Questions
<p>1. General information (approximately five minutes): (This section will highlight the participant's experience and background).</p>	<p>1) What is your profession? - Academic staff - Architectural professional</p> <p>2) How long have you been working in your role? - Less than five years - 5 – 9 years - 10 – 14 years - 15 – 19 years - 20 – 24 years - 25 – 29 years - 30 years or more</p> <p>3) Please provide two or three examples of building and ground relationship projects or research in which you have participated:</p>
<p>2. Architectural designs for the building and ground relationship (approximately 15 minutes): (This section will explore building and ground designs and how participants feel about this issue, based on their background)</p>	<p>Issues and Challenges</p> <p>4) What types of ground form part of your designs? 5) What types of ground do you prefer to use in your designs? 6) What issues or challenges require consideration during the first stage of building design on flat or sloped ground? 7) During the first design stage, what design processes do you use when designing a building on the ground?</p>
	<p>Historical Development</p>
	<p>8) This timeline represents the development of physical building and ground designs over the last 100 years. 9) Do you think this timeline accurately represents the development of physical building and ground designs? Or do you want to change anything?</p>

Chapter 4: Analysis and Synthesis of Building and Ground Relationship

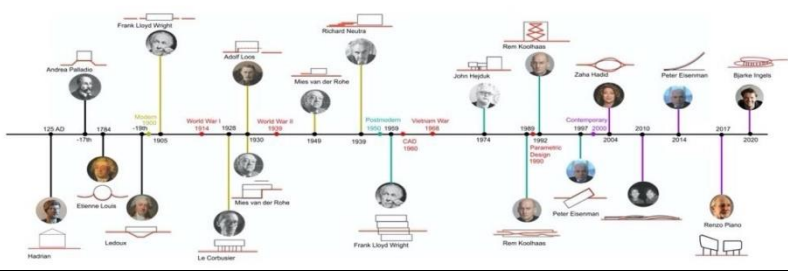
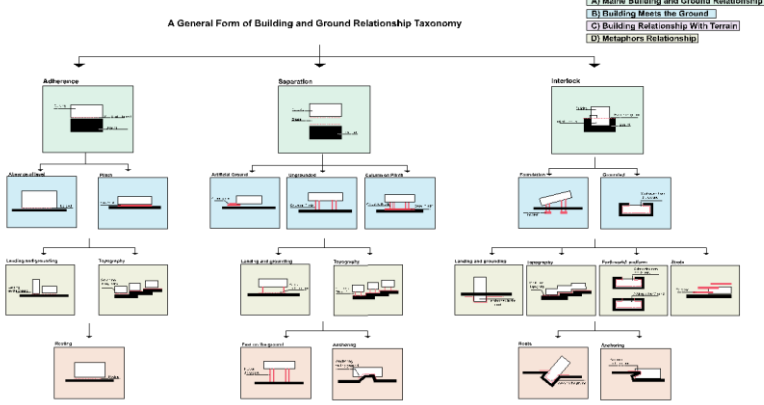
Categories	Set of Questions
<p>experience, knowledge, and preferences. This section aims to highlight building and ground relationship challenges facing the architecture practice during the early design stage).</p>	 <p>Resources</p>
	<p>10) Which of the following do you consider viable resources that help illustrate the building and ground relationship? 11) Written academic papers and articles (academic literature). 12) Case studies (photographs) of projects/architectural precedents. Others (please specify). 13) Are you aware of any analytical or generative design tools which can help you design a building in relation to the ground? If yes, can you please specify?</p>
<p>3. Building and ground relationship taxonomy (approximately 20 minutes):</p> <p>(This section will focus on validating the building and ground relationship taxonomy collected from the literature review. The section aims to evaluate the created taxonomy content, name or title of the taxonomy and visual appearance)</p>	<p>Taxonomy Validation</p> <p>14) The following diagram resulted from the literature review to describe the building and ground relationship.</p>  <p>15) Is this taxonomy information helpful for architects during the early design stage? Do you want to add or delete? (Feel free to describe by drawing the relationship that requires improvement)</p> <p>16) How can the previous diagram be improved? a. How can the title and labelling be improved? b. How can the visual diagram be improved? (Feel free to describe by drawing the relationship that requires improvement)</p> <p>Importance of Taxonomy</p>

Chapter 4: Analysis and Synthesis of Building and Ground Relationship

Categories	Set of Questions
	17) In your opinion, how important is it to have a specific building and ground relationship taxonomy in the early design stage? Why?
4. A computational design tool to cluster and classify building and ground relationships (ten minutes): (This section will focus on exploring the importance of classifying and clustering building and ground relationships. It also aims to uncover the need and benefit of classifying and clustering the computational design)	Importance of Computational design tool 18) Do you, as an architect/academic, think it is important during the early design stage to have a computational tool that can classify and cluster the building and ground precedents into different groups? 19) Why do you think this computational tool is important/not important?
	Benefits of the Computational design tool
	20) How do you think this building and ground relationship taxonomy will benefit architects and the architectural discipline during the early design stage? 21) Are you happy to see the result of the tool?

4.2.2. Analysis of Interview Responses

The following highlight the prime architect's responses to the interview questions⁽¹⁷⁾.

Section (1) General information:

1. Architectural experience for the interviewee:

- Three of the five interviewees were academic staff, while all practice architecture or have done so at some point in their careers.
- Participants have an average experience of more than ten years; one participant has experience of over 20 years, and another participant has experience of more than 30 years.
- The ground was considered in the design of the building during the interviewee's career.

2. Examples of projects:

- STC Campus is an urban project sharing a unique relationship with the ground, which separates it from its surroundings. A key objective of the project involves creating an

⁽¹⁷⁾ See Appendix: Responses from the Interviews with Architects

Chapter 4: Analysis and Synthesis of Building and Ground Relationship

urban and architectural identity for STC Campus that reflects the nature and power of the company (Figure 4.1).

- Twelve dwellings designed by bRijUNi architects in Jaen, Spain are embedded in the ground, which gives this project a solid relationship with the ground. This project was built on varied topography and in a small area; therefore, the architect inserted the building to create more architecturally special spaces (Figure 4.2).



Figure 4.1: STC Campus (designed by the interviewee)



Figure 4.2: Twelve dwellings designed by bRijUNi architects

- One of the unique aspects of Obama's Public Library is its relationship with the ground. A random grid of columns used in the project separates the building from its surrounding context. Moreover, part of the building has a different method of meeting the ground, which is set directly to the ground (Figure 4.3).

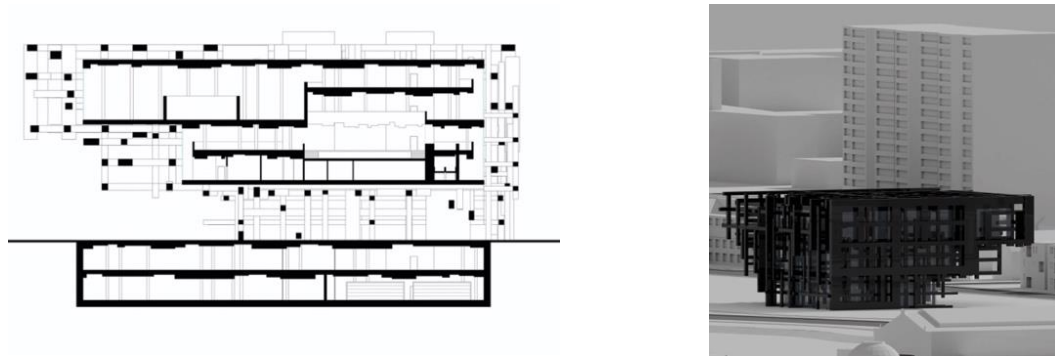

Figure 4.3: Obama's Public Library (designed by the interviewee)

- Project Jabal Omar in Makkah has diverse and robust typography. During this project, interviewee participants and his team study the slope and categorise it into different conditions before determining the most effective way to address them. To handle these situations, they use a basic landscape unit. Additionally, they place the building on terraces to mimic the topography of the mountain. The result is a better view, better ventilation, and less mountain cutting. All these ideas were based on understanding the ground and the relationship between the building and the ground.
- A community for older people in Ekram village in Al Baha, Saudi Arabia. The strong topography of this project prompted the decision to design the slope in the form of an architectural terrace, which would reflect the existing cultural landscape. Moreover, the interviewee participant and his team designed a bridge to connect the houses and the services, thereby improving the elderly's mobility.

Section (2) Architectural Designs for the Building and Ground Relationship:

1. The preferred architectural ground:

- The interviewee design primarily focuses on flat ground. Nevertheless, there are exceptions, such as the Ekram village, the Jabal Omar project, 12 dwellings in Jaen and Al Bohierat City, designed to be built on slopes.
- Architects often have different preferences; some prefer working with flat ground so the architect can manipulate it by cutting and filing, enabling the architect to create the ground level according to the project criteria. In contrast, other architects prefer to work on slopes or topography grounds, as the topography gives the site distinct characteristics.
- To give a more three-dimensional response, architects prefer slopes that face the prevailing wind or views.

Chapter 4: Analysis and Synthesis of Building and Ground Relationship

- Some architects prefer the terrace ground to create opportunities and deal more easily with the terrace ground as the terrace ground is a repetitive flat ground with different levels.

2. Issues and challenges:

- Any architectural design involves two main deliverables: the ground "site" and the architectural "function programme". The challenge involves analysing the site and determining its advantages and disadvantages. The second challenge consists of matching the function programme with the existing ground.
- It remains imperative to consider the structure in any architectural project, regardless of its construction on a slope or flat ground.

3. The design processes:

- The first step involves analysing the site. Alongside topographical analysis, hydrological analysis, soil specifications and studying the context of the surrounding area, pedestrian circulation and infrastructure, an environmental analysis also takes place.
- The second step involves establishing the starting and end points of the construction based on a thorough understanding of the surrounding context's infrastructure and land dimensions.
- Rather than constructing the road and building and leaving the rest to the landscape, a conventional design process used in the architectural practices, the participants suggest starting at the ground and responding to the architectural solution to the ground.

4. Building and ground historical development:

- The timeline generalised the development of the building and ground and presented it in a professional manner.
- According to Anthony Vidler, "the wars are the ones shaping the different periods in the history of architecture", so it remains essential to see first and second world wars in the timeline.
- According to this timeline, architects like Le Corbusier and Renzo Bino drove a similar architectural approach.
- According to the timeline, modern architects consider the ground as the receiver. However, architects after 1950 consider the relationship between the building and the ground.

Chapter 4: Analysis and Synthesis of Building and Ground Relationship

- The CAD and Parametric revolution in the contemporary period have provided architects with more tools to "shape the ground" and create a complex approach to the ground.

5. Knowledge resources:

- Building and ground relationships are best illustrated by the case study image because the image clearly demonstrates the relationship. Images often remain in architects' minds longer than text.
- Further, written academic papers and books are essential to extending the architects' understanding and identifying the purpose of the proposed relationship.
- The use of 3D models also helps clarify the relationship between a building and its surroundings.
- The relationship between the building and the ground is usually modelled manually as no tools can assist architects in designing, classifying, or generating a solution.

Section (3) Building and ground relationship taxonomy:

1. Taxonomy Validation

a. The usefulness of the taxonomy

- Taxonomy, as educational knowledge, will contribute to the architecture discipline.
- Tools for practice can clarify the relationship between buildings and the ground.
- Taxonomy can address other aspects, such as environmental, structural, and programming aspects.

b. Validation diagram title and labelling

- Taxonomies require definition architecturally and lexically.
- A topography label should specify interlock topography, separation topography and adherence topography.

c. Validation visual diagram

- The diagrams are visually clear. A legend for the diagrams should go next to the horizontal matrix.

2. Importance of the taxonomy

- The ground issue begins in the early design phase, meaning that at this stage, the taxonomy and diversity of this taxonomy become necessary.
- This taxonomy can serve as an excellent reference for all architectural practices.

Chapter 4: Analysis and Synthesis of Building and Ground Relationship

- A taxonomy will assist the architect in solving the function and formal problems more effectively.

Section (4) A Computational Design Tool to Cluster and Classify Building and Ground Relationships:

1. Classify and cluster the building and ground precedent to different groups

- The architects will benefit from categorising and clustering architectural precedents into groups.
- The classified groups mean architects can save time and effort when researching similar architectural precedents.
- At the early stage of the design process, the classified groups will clarify how architects' approaches fit within the architectural history or timeline the study has provided.
- There remains a need for classified precedents groups as a source of education information at all stages, not just in the first design phase.

4.3. Architectural Precedents Collection and Visualisation

4.3.1. Statistical Analysis

This section presents the statistical analysis of the gathered architectural precedents. A total of 500 architectural precedents were collected and archived⁽¹⁸⁾ (Figure 4.4).

ID	Architect Name	Building Name	Status	Type	Building Type	Year	Country	City
1	1	1	1	1	1	2019	North America	United States of America, New York
2	2	2	2	2	2	2019	Europe	Spain
3	3	3	3	3	3	2019	North America	United States of America, Florida
4	4	4	4	4	4	2019	Europe	Spain
5	5	5	5	5	5	2019	Europe	Spain
6	6	6	6	6	6	2019	Europe	Spain
7	7	7	7	7	7	2019	Europe	Spain
8	8	8	8	8	8	2019	Europe	Spain
9	9	9	9	9	9	2019	Europe	Spain
10	10	10	10	10	10	2019	Europe	Spain
11	11	11	11	11	11	2019	Europe	Spain
12	12	12	12	12	12	2019	Europe	Spain
13	13	13	13	13	13	2019	Europe	Spain
14	14	14	14	14	14	2019	Europe	Spain
15	15	15	15	15	15	2019	Europe	Spain
16	16	16	16	16	16	2019	Europe	Spain
17	17	17	17	17	17	2019	Europe	Spain
18	18	18	18	18	18	2019	Europe	Spain
19	19	19	19	19	19	2019	Europe	Spain
20	20	20	20	20	20	2019	Europe	Spain
21	21	21	21	21	21	2019	Europe	Spain
22	22	22	22	22	22	2019	Europe	Spain
23	23	23	23	23	23	2019	Europe	Spain
24	24	24	24	24	24	2019	Europe	Spain
25	25	25	25	25	25	2019	Europe	Spain
26	26	26	26	26	26	2019	Europe	Spain
27	27	27	27	27	27	2019	Europe	Spain
28	28	28	28	28	28	2019	Europe	Spain
29	29	29	29	29	29	2019	Europe	Spain
30	30	30	30	30	30	2019	Europe	Spain
31	31	31	31	31	31	2019	Europe	Spain
32	32	32	32	32	32	2019	Europe	Spain
33	33	33	33	33	33	2019	Europe	Spain
34	34	34	34	34	34	2019	Europe	Spain
35	35	35	35	35	35	2019	Europe	Spain
36	36	36	36	36	36	2019	Europe	Spain
37	37	37	37	37	37	2019	Europe	Spain
38	38	38	38	38	38	2019	Europe	Spain
39	39	39	39	39	39	2019	Europe	Spain
40	40	40	40	40	40	2019	Europe	Spain
41	41	41	41	41	41	2019	Europe	Spain
42	42	42	42	42	42	2019	Europe	Spain
43	43	43	43	43	43	2019	Europe	Spain
44	44	44	44	44	44	2019	Europe	Spain
45	45	45	45	45	45	2019	Europe	Spain
46	46	46	46	46	46	2019	Europe	Spain
47	47	47	47	47	47	2019	Europe	Spain
48	48	48	48	48	48	2019	Europe	Spain
49	49	49	49	49	49	2019	Europe	Spain
50	50	50	50	50	50	2019	Europe	Spain
51	51	51	51	51	51	2019	Europe	Spain
52	52	52	52	52	52	2019	Europe	Spain
53	53	53	53	53	53	2019	Europe	Spain
54	54	54	54	54	54	2019	Europe	Spain
55	55	55	55	55	55	2019	Europe	Spain
56	56	56	56	56	56	2019	Europe	Spain
57	57	57	57	57	57	2019	Europe	Spain
58	58	58	58	58	58	2019	Europe	Spain
59	59	59	59	59	59	2019	Europe	Spain
60	60	60	60	60	60	2019	Europe	Spain
61	61	61	61	61	61	2019	Europe	Spain
62	62	62	62	62	62	2019	Europe	Spain
63	63	63	63	63	63	2019	Europe	Spain
64	64	64	64	64	64	2019	Europe	Spain
65	65	65	65	65	65	2019	Europe	Spain
66	66	66	66	66	66	2019	Europe	Spain
67	67	67	67	67	67	2019	Europe	Spain
68	68	68	68	68	68	2019	Europe	Spain
69	69	69	69	69	69	2019	Europe	Spain
70	70	70	70	70	70	2019	Europe	Spain
71	71	71	71	71	71	2019	Europe	Spain
72	72	72	72	72	72	2019	Europe	Spain
73	73	73	73	73	73	2019	Europe	Spain
74	74	74	74	74	74	2019	Europe	Spain
75	75	75	75	75	75	2019	Europe	Spain
76	76	76	76	76	76	2019	Europe	Spain
77	77	77	77	77	77	2019	Europe	Spain
78	78	78	78	78	78	2019	Europe	Spain
79	79	79	79	79	79	2019	Europe	Spain
80	80	80	80	80	80	2019	Europe	Spain
81	81	81	81	81	81	2019	Europe	Spain
82	82	82	82	82	82	2019	Europe	Spain
83	83	83	83	83	83	2019	Europe	Spain
84	84	84	84	84	84	2019	Europe	Spain
85	85	85	85	85	85	2019	Europe	Spain
86	86	86	86	86	86	2019	Europe	Spain
87	87	87	87	87	87	2019	Europe	Spain
88	88	88	88	88	88	2019	Europe	Spain
89	89	89	89	89	89	2019	Europe	Spain
90	90	90	90	90	90	2019	Europe	Spain
91	91	91	91	91	91	2019	Europe	Spain
92	92	92	92	92	92	2019	Europe	Spain
93	93	93	93	93	93	2019	Europe	Spain
94	94	94	94	94	94	2019	Europe	Spain
95	95	95	95	95	95	2019	Europe	Spain
96	96	96	96	96	96	2019	Europe	Spain
97	97	97	97	97	97	2019	Europe	Spain
98	98	98	98	98	98	2019	Europe	Spain
99	99	99	99	99	99	2019	Europe	Spain
100	100	100	100	100	100	2019	Europe	Spain
101	101	101	101	101	101	2019	Europe	Spain
102	102	102	102	102	102	2019	Europe	Spain
103	103	103	103	103	103	2019	Europe	Spain
104	104	104	104	104	104	2019	Europe	Spain
105	105	105	105	105	105	2019	Europe	Spain
106	106	106	106	106	106	2019	Europe	Spain
107	107	107	107	107	107	2019	Europe	Spain
108	108	108	108	108	108	2019	Europe	Spain
109	109	109	109	109	109	2019	Europe	Spain
110	110	110	110	110	110	2019	Europe	Spain
111	111	111	111	111	111	2019	Europe	Spain
112	112	112	112	112	112	2019	Europe	Spain
113	113	113	113	113	113	2019	Europe	Spain
114	114	114	114	114	114	2019	Europe	Spain
115	115	115	115	115	115	2019	Europe	Spain
116	116	116	116	116	116	2019	Europe	Spain
117	117	117	117	117	117	2019	Europe	Spain
118	118	118	118	118	118	2019	Europe	Spain
119	119	119	119	119	119	2019	Europe	Spain
120	120	120	120	120	120	2019	Europe	Spain
121	121	121	121	121	121	2019	Europe	Spain
122	122	122	122	122	122	2019	Europe	Spain
123	123	123	123	123	123	2019	Europe	Spain
124	124	124	124	124	124	2019	Europe	Spain
125	125	125	125	125	125	2019	Europe	Spain
126	126	126	126	126	126	2019	Europe	Spain
127	127	127	127	127	127	2019	Europe	Spain
128	128	128	128	128	128	2019	Europe	Spain
129	129	129	129	129	129	2019	Europe	Spain
130	130	130	130	130	130	2019	Europe	Spain
131	131	131	131	131	131	2019	Europe	Spain
132	132	132	132	132	132	2019	Europe	Spain
133	133	133	133	133	133	2019	Europe	Spain
134	134	134	134	134	134	2019	Europe	Spain
135	135	135	135	135	135	2019	Europe	Spain
136	136	136	136	136	136	2019	Europe	Spain
137	137	137	137	137	137	2019	Europe	Spain
138	138	138	138	138	138	2019	Europe	Spain
139	139	139	139	139	139	2019	Europe	Spain
140	140	140	140	140	140	2019	Europe	Spain
141	141	141	141	141	141	2019	Europe	Spain
142	142	142	142	142	142	2019	Europe	Spain
143	143	143	143	143	143	2019	Europe	Spain
144	144	144	144	144	144	2019	Europe	Spain
145	145	145	145	145	145	2019	Europe	Spain
146	146	146	146	146	146	2019	Europe	Spain
147	147	147	147	147	147	2019	Europe	Spain
148	148	148	148	148	148	2019	Europe	Spain
149	149	149	149	149	149	2019	Europe	Spain
150	150	150	150	150	150	2019	Europe	Spain
151	151	151	151	151	151	2019	Europe	Spain
152	152	152	152	152	152	2019	Europe	Spain
153	153	153	153	153	153	2019	Europe	Spain
154	154	154	154	154	154	2019	Europe	Spain
155	155	155	155	155	155	2019	Europe	Spain
156	156	156	156	156	156	2019	Europe	Spain
157	157	157	157	157	157	2019	Europe	Spain
158	158	158	158	158	158	2019	Europe	Spain
159	159	159	159	159	159	2019	Europe	Spain
160	160	160	160	160	160	2019	Europe	Spain
161	161	161	161	161	161	2019	Europe	Spain
162	162	162	162	162	162	2019	Europe	Spain
163	163	163	163	163	163	2019	Europe	Spain
164	164	164	164	164	164	2019	Europe	Spain
165	165	165	165	165	165	2019	Europe	Spain
166	166	166	166	166	166	2019	Europe	Spain
167	167	167	167	167	167	2019	Europe	Spain
168	168	168	168	168	168	2019	Europe	Spain
169	169	169	169	169	169	2019	Europe	

Chapter 4: Analysis and Synthesis of Building and Ground Relationship

contemporary period, which has a wider variety of examples and a more pronounced relationship with the ground.

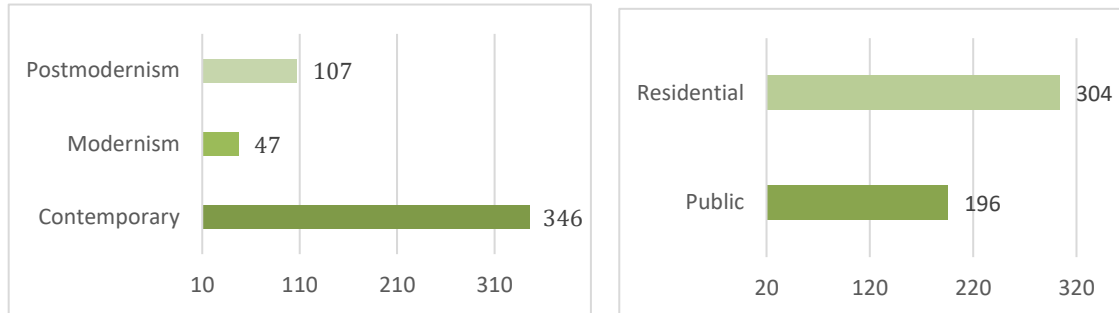

Figure 4.5: Period of collected architectural precedents

- **Type of Architectural Precedents:** Most precedents (60%) comprised residential buildings, representing 304 of the collected data. The remainder were public precedents, which totalled 196. This selection aims to examine a different project scale, but the focus is on a residential building with two to three floors. Due to this study's aims, most of the data collected were building case studies (468), along with urban cases (9) and landscape projects (5) (Figure 4.6).

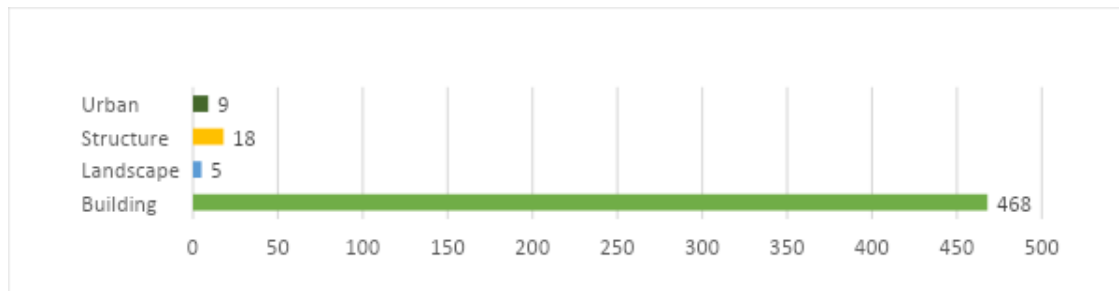

Figure 4.6: Type of collected architectural precedents

- **Status of Architectural Precedents:** There were 458 architectural precedents that were built. There were 41 cases with conceptual ideas that were not yet built. There was only one case built and then demolished. Several of the projects remain under construction and will be completed soon; therefore, they form part of the as-built category (Figure 4.7).

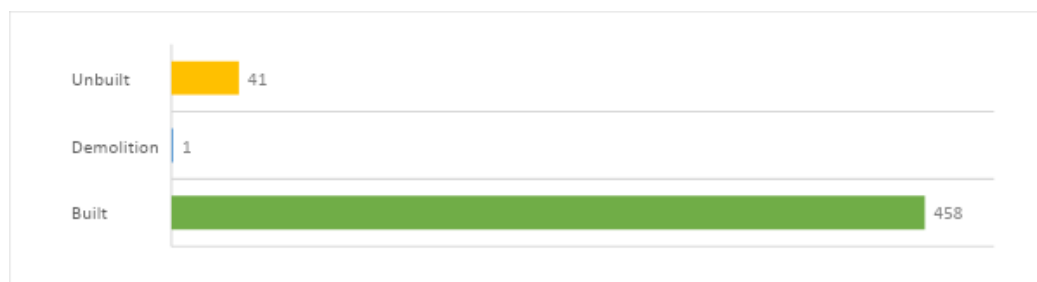

Figure 4.7: Status of collected architectural precedents

Chapter 4: Analysis and Synthesis of Building and Ground Relationship

- **Location of Architectural Precedents:** To generalise the data, precedents were gathered from around the world, and the variation in the location of the cases underwent consideration. It should be noted, however, that most of the precedents came from North America and Europe, which amounts to more than 340 of the total precedents (Figure 4.8). In terms of how the building meets the ground, North America and Europe showed the greatest variation (Figure 4.9). Approximately 9 case studies have not been located, which means they remain conceptual or unbuilt.

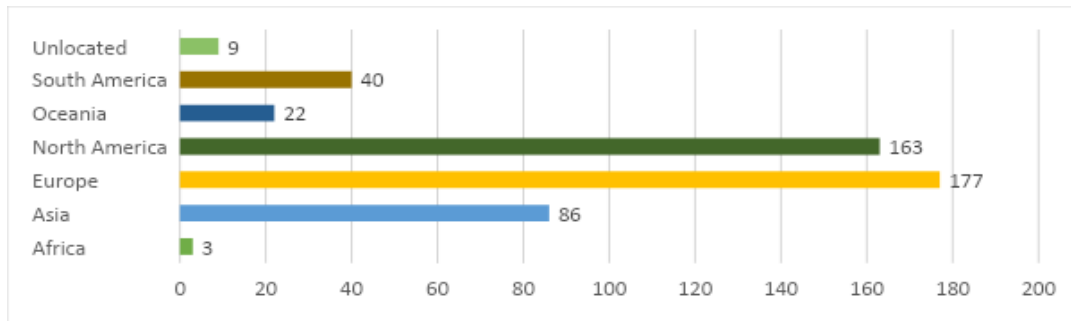

Figure 4.8: Location of collected architectural precedents

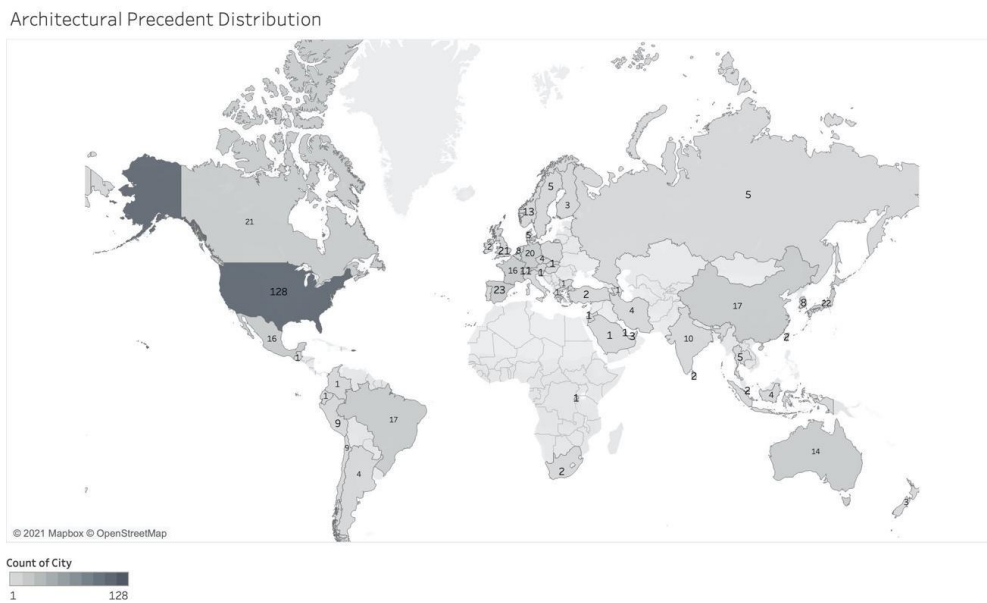

Figure 4.9: Distribution of collected architectural precedents

- **Repetition of Architectural Precedents:** Based on the collected data, Frank Lloyd Wright proved the most repetitive architect in our database with 23 instances, followed by Mies Van der Rohe with 15 instances and Mackay-Lyons Sweetapple Architects with 13 instances (Figure 4.10).

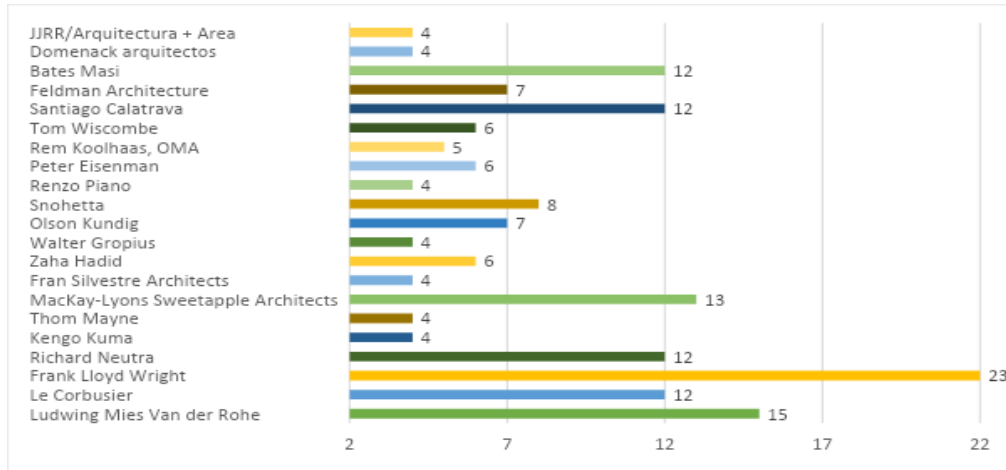

Figure 4.10: Repetition of collected architectural precedents

4.4. Sorting Data Techniques; Image Sorting of Architectural Precedents

The following section presents the results of the image sorting survey. The image sorting fell into two surveys. Firstly, (Section 4.4.1) features the main building and ground relationship image sorting survey responses. Secondly, (Section 4.4.2) features the building meets the ground image sorting survey responses.

4.4.1. Main Building and Ground Relationship Image Sorting Survey Responses

The first survey began on November 24, 2019, and ended on April 30, 2021. The survey was open for 17 months. In total, 86 participants opened the survey; however, 42 completed the survey, representing approximately 49% of the total participants. On average, participants took ten minutes and 27 seconds to complete the sorting task. The longest time was approximately 34 minutes, and the shortest was approximately 2 minutes. Participants primarily came from the United Kingdom (Figure 4.11).

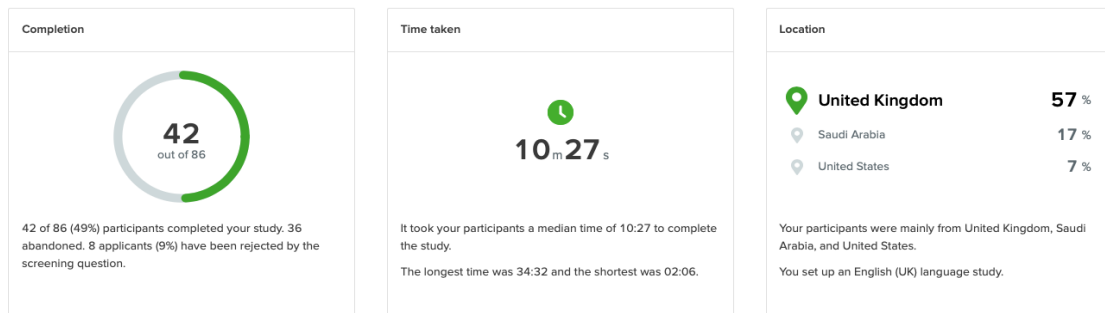

Figure 4.11: The completion, time taken and location of the participants on main building and ground relationship image sorting survey

4.4.1.1. Participant Analysis

This section contains information about the participants. The responses received from nine countries totalled 48. The final sample size of 42 architects was achieved with a reasonable response rate of 87.5% after arranging and revising the returned survey (Figure 4.12). Several responses did not qualify due to a lack of understanding of the diagrams or incomplete responses. A total of 25 participants were undergraduate and graduate students. The remaining participants were architectural academic staff, with seven participants, and architectural practitioners, with ten participants (Figure 4.13).

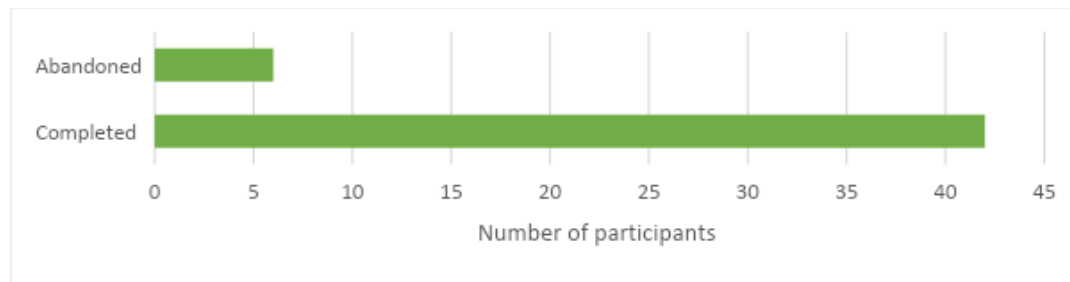

Figure 4.12: Number of participants that completed or abandoned the main building and ground relationship image sorting survey

Answer	Percentage	Count
Undergraduate Architecture Student	14.3%	6
Graduated Architecture Student (Master or PhD)	45.2%	19
Architectural Academic Staff (lecturer or Reader or Professor)	16.7%	7
Architectural Practitioner	23.8%	10
Non-Architect	0%	0

Figure 4.13: Participants' careers who responded to the main survey on building and ground relationships

Due to the online distribution of the sorting survey link, the architectural participants came from 9 different countries (Figure 4.14). A significant number of participants came from the United Kingdom and Saudi Arabia (Figure 4.15).

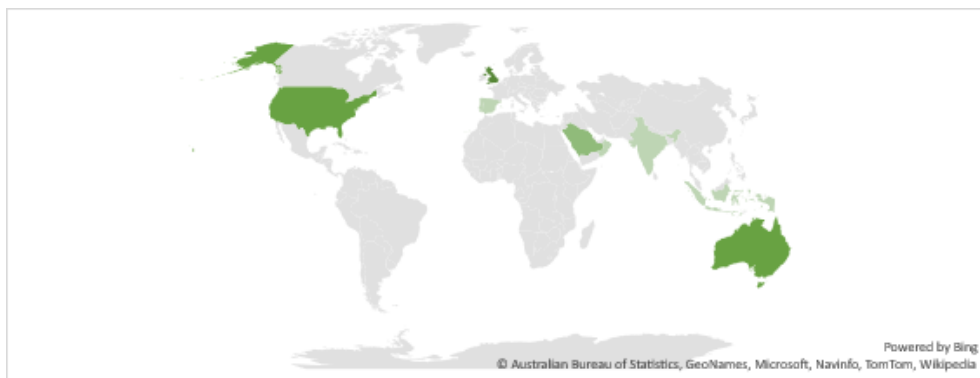

Figure 4.14: The worldwide distribution of the participants on the main building and ground relationship image sorting survey

Chapter 4: Analysis and Synthesis of Building and Ground Relationship

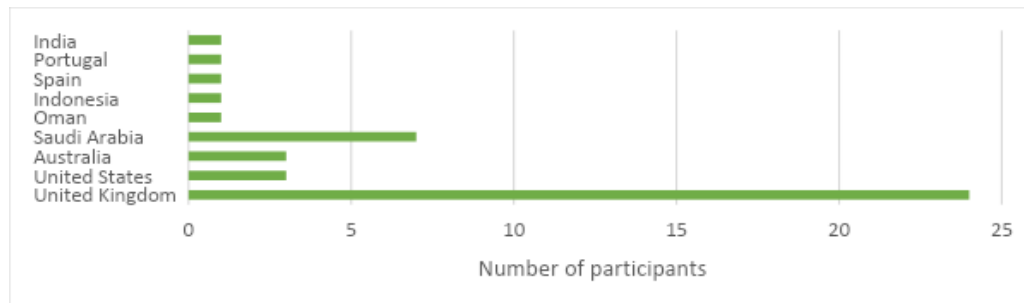

Figure 4.15: Number of responses received from different countries to the main building and ground relationship image sorting survey

Surveys occurred between November 2019 and April 2021; however, sorting was only completed by the participants during the following months in November 2019, December 2019, April 2020, May 202, February 2021, March 2021, and April 2021. Most responses were received in the first quarter of 2021 (Figure 4.16).

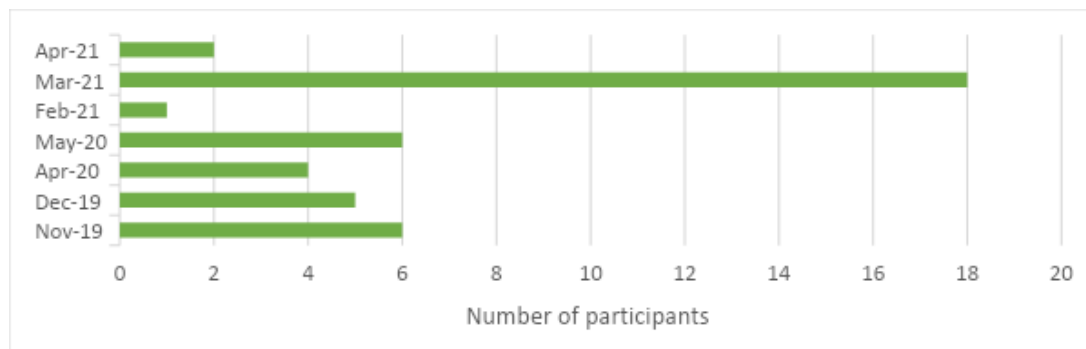

Figure 4.16: The time of the responses received to the main building and ground relationship image sorting survey

4.4.1.2. Pre-Study Questions Analysis

Prior to the sorting task, seven questions were asked. Completing the workshop required answering all questions. The seven questions were successfully answered by all 42 participants (Table 4.2).

Table 4.2: Number of participants answering pre-study questions

No. of question	Type of question	I understand	I don't understand
Question 1	Participant Information Sheet	42	0
Question 2	Consent Form	42	0
Question 3	Participant Name (optional)	NA	NA
Question 4	General introduction	42	0
Question 5	Interlock diagram	42	0
Question 6	Separation diagram	42	0
Question 7	Adherence diagram	42	0
	Total number of participants	42	0

4.4.1.3. Image Sorting Task Analysis

This survey involved sorting 269 images. Several participants sorted the images. The figure below illustrates the agreement between all participants. There were 238 (88%) images grouped in the same cluster; however, 31 (12%) images were grouped in different clusters (Figure 4.17). In spite of this, not all 238 images were 100% grouped in the same cluster, but because more than 50% of the participants were in agreement, we considered their answers as agreements (Figure 4.17).

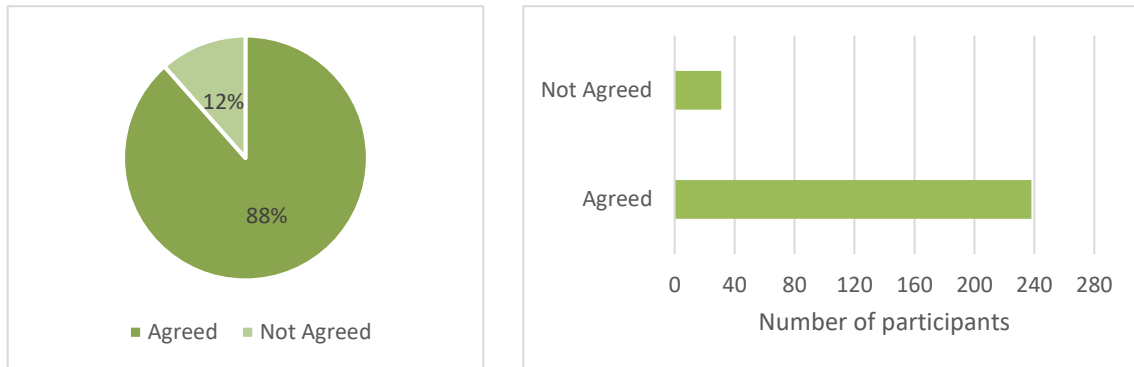

Figure 4.17: The agreements between the participants for all images

The two graphs below illustrate the number of images that match the expert clustering answer (the researcher). The expert grouping matched 219 (81%) images; however, 50 (19%) images did not match (Figure 4.18).

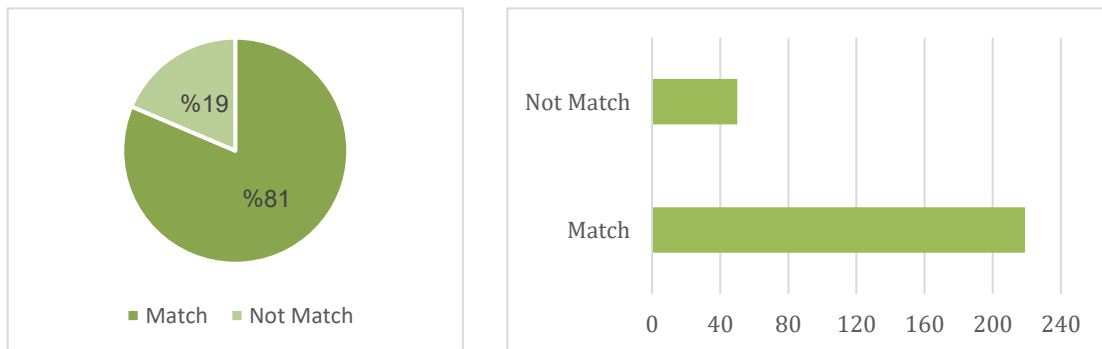

Figure 4.18: The number of images that match the expert clustering answer (The researcher)

The table⁽¹⁹⁾ shows all the 269 images sorted into the three different main building and ground relationships. A list of all the images and their IDs is appended to this research.

⁽¹⁹⁾ See Appendix VII: Responses from the Participants Main Building and Ground Relationship Sorting Survey

Chapter 4: Analysis and Synthesis of Building and Ground Relationship

The researcher utilised the confusion matrix to conclude the analysis results of the building and ground relationship sorting survey. This survey involved 1,255 images: 894 images were grouped in the same cluster, and 361 images were ground with different classes (Figure 4.19).

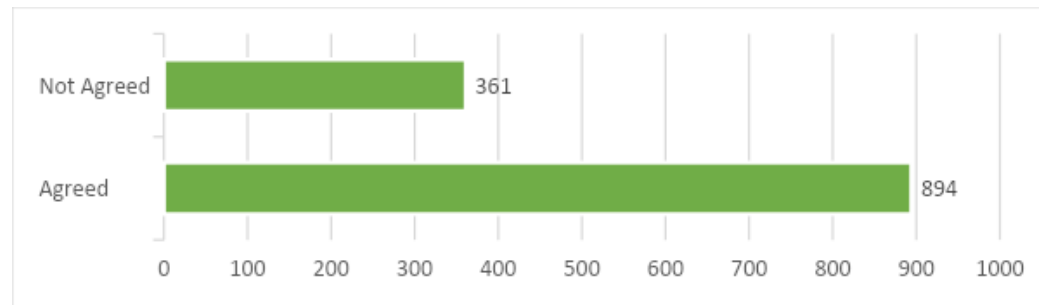

Figure 4.19: A total of 1255 images sorted, 894 images were grouped in same cluster, however, 361 images were ground with different classes

- The confusion matrix (Table 4.3) indicates 146 total (incorrect) interlock images clustered within different classes; most of them fall under the category of adherence (120 images).
- In terms of separation, the confusion matrix indicates a total of 110 (incorrect) separation images grouped into different classes; most of these falls under the category of adhesion (69 images).
- Finally, for adherence, the confusion matrix indicates a total of 105 (incorrect) separation images grouped into different classes; most of these falls under the category of interlock (69 images).

This indicates a crucial finding that the participants have difficulties sorting the interlock and adherence images. Approximately 20% of the adherence image was sorted in the interlock group. Approximately 37% of the interlock image was sorted in the adherence group. Consequently, interlocking and adherence appear the most problematic areas in the survey.

Table 4.3: A confusion matrix for all the main building and ground relationship image sorting surveys

		Actual Values		
		Interlock	Separation	Adherence
Sorted Values	Interlock	319	41	72
	Separation	26	313	33
	Adherence	120	69	262

4.4.1.4. Post-Study Questions Analysis

After the participant finished the sorting task, a feedback question estimated the amount of participant satisfaction and ease of the interface software (Figure 4.20). The survey was positively received by more than 33 out of 42 participants.

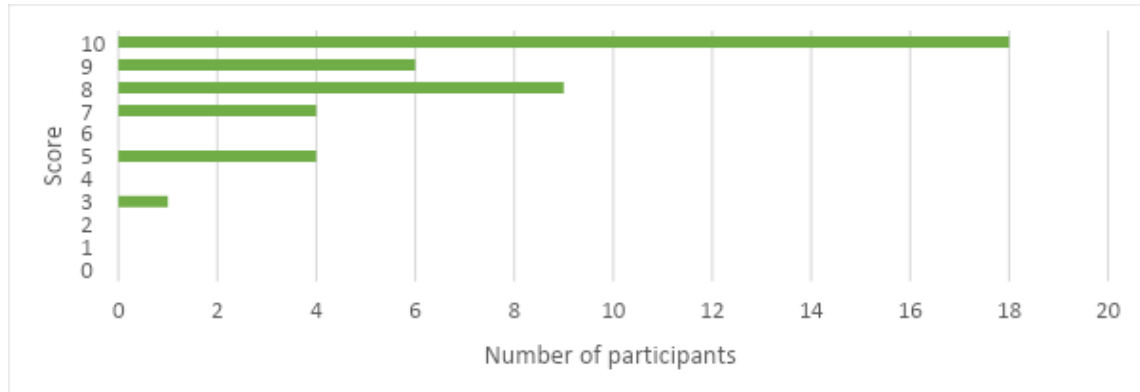

Figure 4.20: Score of the participants or the main building and ground relationship image sorting survey

4.4.2. The Building Meets the Ground Image Sorting Survey Responses

The second survey launched on May 14, 2021, and closed on May 27, 2022. The workshop was open for 12 months. The survey featured 71 participants, but only 35 completed it. This represents 49% of the participants. The participants took an average of 11 minutes and eight seconds to complete the sorting task. Approximately one hour and one minute was the longest time, while the shortest time was approximately three minutes. Most participants came from the United Kingdom (Figure 4.21).

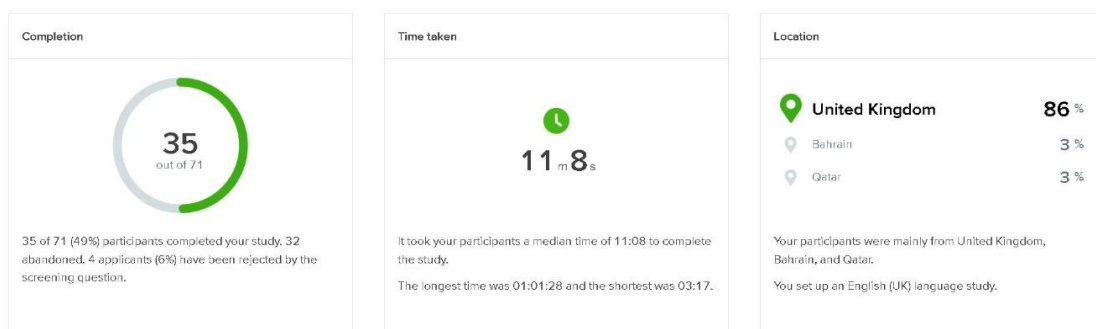

Figure 4.21: The completed number, time taken, and the location of the building meets the ground image sorting survey participants

4.4.2.1. Participants Analysis

This part focuses on the data collected about the participants. A total number of 67 responses from 14 countries were returned. After arranging and revising the returned survey, a final overall sample size of 35 architect participants was achieved with a reasonable response rate

Chapter 4: Analysis and Synthesis of Building and Ground Relationship

of 52.2%. Reasons for the disqualification of 6 responses included a misunderstanding of the diagrams or incomplete responses (Figure 4.22). A total of 25 participants were undergraduate and graduate students; however, the other participants were 4 architectural academic staff and 6 architectural practitioners (Figure 4.23).

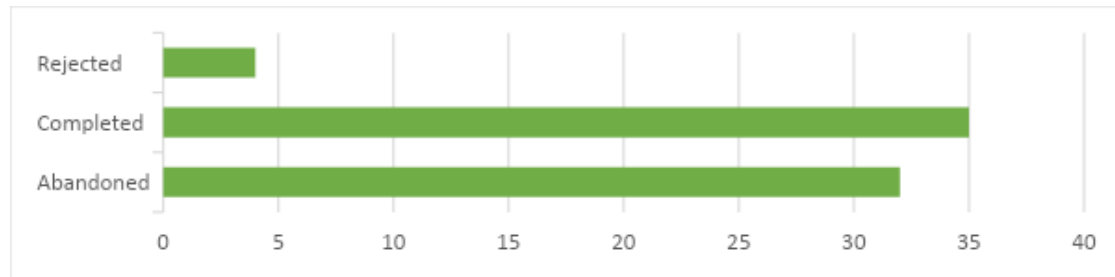

Figure 4.22: Number of participants completed the building meets the ground image sorting survey participants

Answer	Percentage	Count
Undergraduate Architecture Student	8.6%	3
Graduated Architecture Student (Master or PhD.)	62.9%	22
Architectural Academic Staff (lecturer or Reader or Professor)	17.1%	6
Architectural Practitioner	11.4%	4
Non-Architect	0%	0

Figure 4.23: Participants' careers who responded to the building meets the ground image sorting survey participants



Figure 4.24: The worldwide distribution of the participants received from "the building meets the ground" image sorting survey

Due to the online distribution of the sorting survey link, the diverse architectural participants came from over 14 different countries (Figure 4.24). Most participants were from the United Kingdom, Saudi Arabia, and Jordan (Figure 4.25).

Chapter 4: Analysis and Synthesis of Building and Ground Relationship

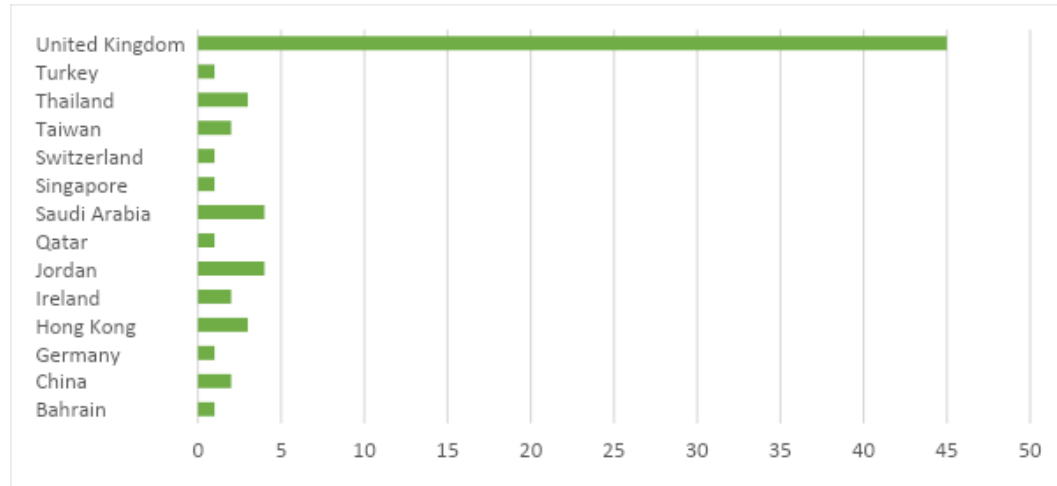

Figure 4.25: Number of responses received from different countries to "the building meets the ground" image sorting survey

The survey took place from May 2021 to May 2022, but the participants were involved in the sorting only during the following months: May 2021, Jun 2021, Nov 2021, Jan 2022, Feb 2022, Apr 2022, and May 2022. Most responses were received in the first quarter of 2021 (Figure 4.26).

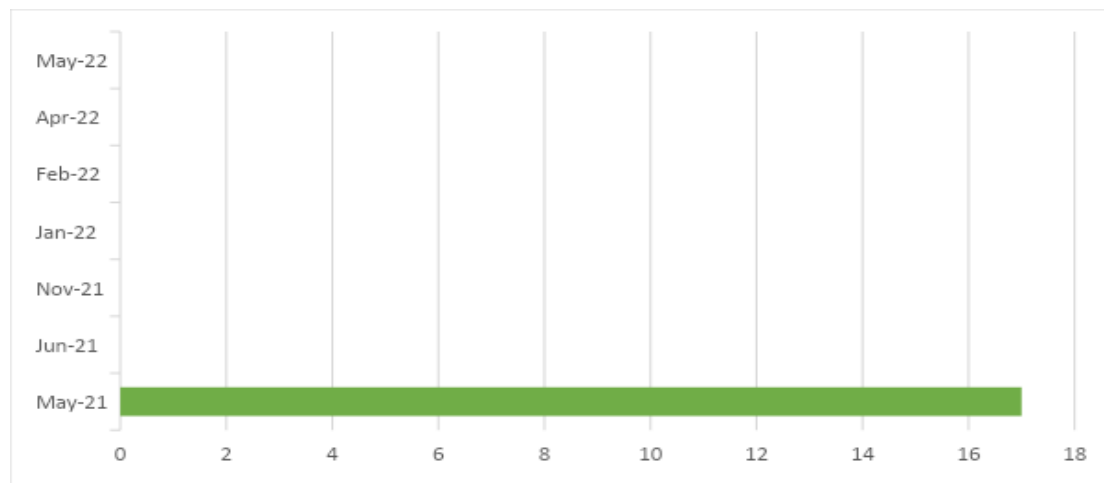

Figure 4.26: The time of the responses received to "the building meets the ground" image sorting survey

4.4.2.2. Pre-Study Questions Analysis

Before sorting, 9 questions were asked. All 35 participants successfully answered the seven questions (Table 4.4).

Chapter 4: Analysis and Synthesis of Building and Ground Relationship

Table 4.4: Number of participants answering pre-study questions

No. of question	Type of question	I understand	I don't understand
Question 1	Participant Information Sheet	34	1
Question 2	Consent Form	35	0
Question 3	Participant Name (optional)	NA	NA
Question 4	General introduction	35	0
Question 5	Grounded diagram	35	0
Question 6	Ungrounded diagram	35	0
Question 7	Foundation diagram	35	0
Question 8	Plinth diagram	33	2
Question 9	Artificial Ground diagram	34	1
Question 9	Absence of Level diagram	33	2
	Total number of participants	33	2

4.4.2.3. Image Sorting Task Analysis

This survey involved 262 sorted images. These images were sorted by different individuals. Therefore, the figure below illustrates the agreements between the participants for all images. There were 179 (69%) images grouped into the same cluster. However, 83 (31%) images were grouped into different clusters (Figure 4.27). Though not all 238 images were grouped in the same cluster, more than 50% of the participants agreed with each other, meaning we considered their responses as agreement (Figure 4.27).

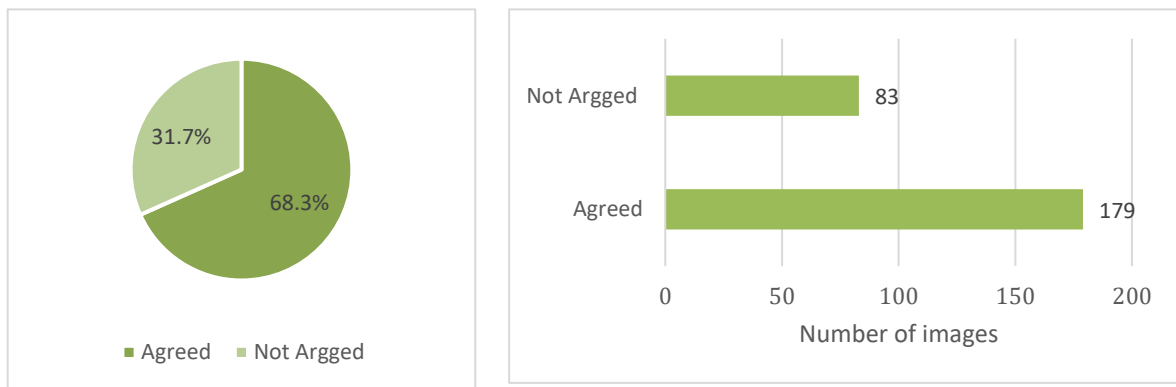

Figure 4.27: The agreements between the participants for all images

Moreover, to demonstrate how the survey matches the expert grouping, the two figures below illustrate the number of images that match the expert clustering answer (the researcher). The findings show that 125 (47.7%) images were matched; however, 137 (52.2%) images were not matched by the expert grouping (Figure 4.28).

Chapter 4: Analysis and Synthesis of Building and Ground Relationship

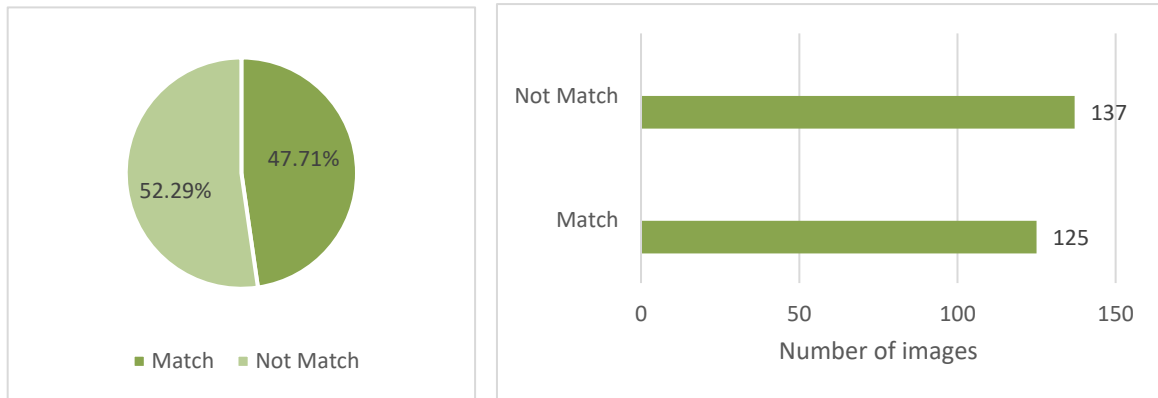

Figure 4.28: The number of images that match the expert clustering answer (The researcher)

The table ⁽²⁰⁾ shows all the 262 images sorted into six different buildings to meet the ground groups. All the images and their ID are appended with this research.

To conclude the analysis results of the building meets the ground relationship sorting survey, a confusion matrix was used. This survey features a total of 1,050 images: 485 images grouped in the same cluster and 565 images that were ground with different classes (Figure 4.29).

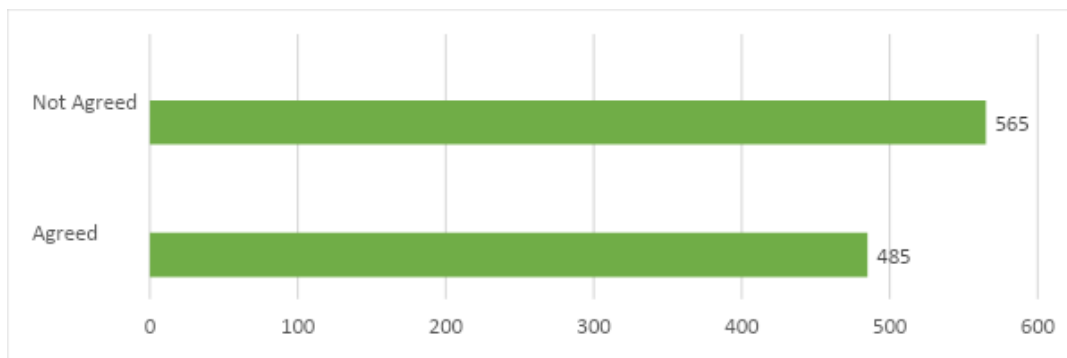

Figure 4.29: A total of 1050 images sorted, 485 images were grouped in same cluster, however, 565 images were ground with different classes

- According to the confusion matrix (Table 4.5), there are 77 total (incorrect) grounded images clustered in different classes. Thus, 40% of the grounded images were interpreted incorrectly by the participants.
- The confusion matrix indicates that out of 269 ungrounded images, 115 are grouped into different classes (incorrect). Therefore, 42% of the ungrounded images were interpreted incorrectly by participants.

⁽²⁰⁾ Appendix VIII: Responses from the Participants Building Meet the Ground Image Sorting Survey (Two)

Chapter 4: Analysis and Synthesis of Building and Ground Relationship

- Based on the confusion matrix, out of 238 foundation images, 173 have been classified in different classes (incorrect). Consequently, 72% of the foundation images were misinterpreted by participants.
- Out of 96 plinth images, 46 have been classified differently (incorrectly) according to the confusion matrix. This development resulted in 66% of the plinth images being misinterpreted by participants.
- Based on the confusion matrix, 32 of the 61 images of artificial ground have been incorrectly classified. The participants thus misinterpreted 52% of the artificial ground images.
- Furthermore, it has been found that out of 197 absence of level images, 104 have been classified in different classes (incorrect). Therefore, 52% of the absence of level images were misinterpreted by participants.

Considering this, a pivotal finding was that participants have difficulties sorting the images of the foundation and plinth. Most participants missed grouping the foundation class with the grounded class (72 images). Therefore, these classes should merge into a single class. Most participants misidentified the plinth class as part of the artificial ground class (19 images). Therefore, these two classes should merge into a single class.

Table 4.5: A confusion matrix to all building meets the ground image sorting survey responses

		Actual Values					
		Grounded	Ungrounded	Foundation	Plinth	Artificial Ground	Absence of level
Sorted Values	Grounded	112	16	72	7	5	25
	Ungrounded	9	154	23	10	9	13
	Foundation	16	37	65	13	6	23
	Plinth	6	30	25	32	6	26
	Artificial Ground	29	19	27	19	29	17
	Absence of level	17	13	26	15	6	93

4.4.2.4. Post-Study Questions Analysis

Participants were asked to complete feedback questions to determine their satisfaction with the interface software and the ease of using it (Figure 4.30). More than 23 out of 33 participants expressed satisfaction with the survey.

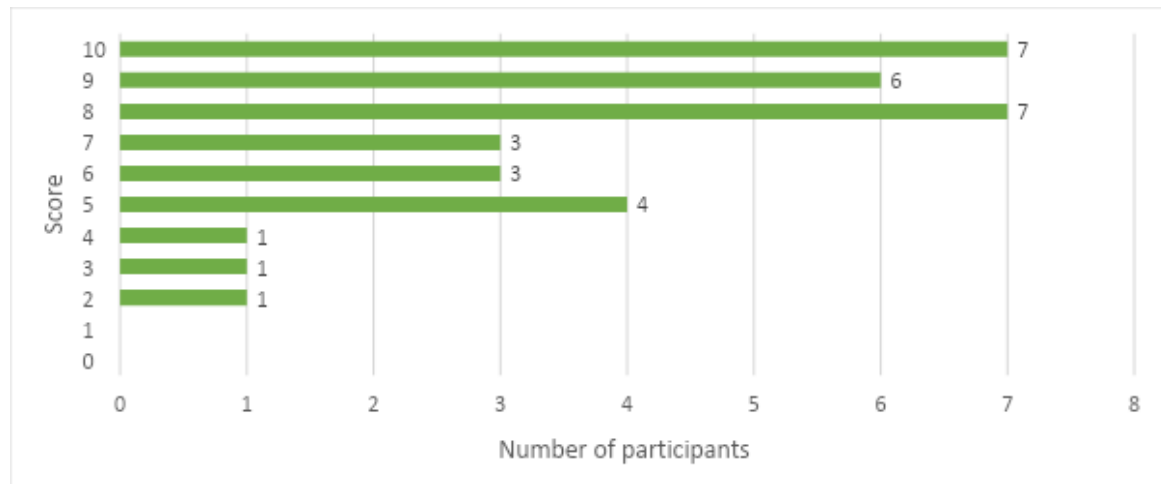

Figure 4.30: Score of the participants of the building meets the ground image sorting survey

Part (B): Generative 3D Graph Topological Model of the Building and Ground Relationship

4.5. Extraction of Parametric Rules from Architectural Precedents

The building and ground parameters were extracted from 500 case studies to understand the relationship between the building and the ground. Additionally, the image sorting survey (Section 4.4) demonstrated the similarity of the most common building and ground relationships. The researcher also uses the lexicon and diagrams to extract the architectural element and create a rule based on Tome Berland's taxonomy (Figure 4.31). Then, this relationship was transferred to rules using the shape grammars approach.

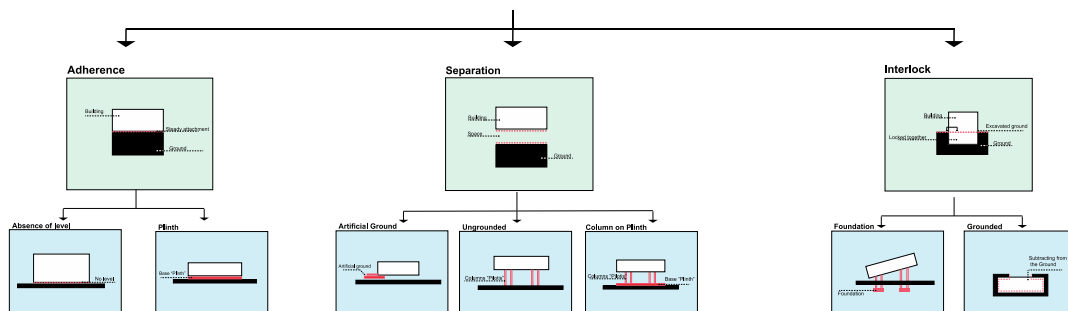

Figure 4.31: Used building and ground relationship taxonomy to extract the rules

4.5.1. Sets of Parametric Rules

A design prototype was developed based on analysing 500 architectural precedents. A set of 76 parametric rules are categorised into six groups and define the language of the relationship between the building and the ground (Table 4.6). To address the geometric aspects such as width, length and height, a mathematical expression was added to the rules.

Table 4.6: Sets of parametric rules that define the language of the building and ground relationship

Set of Rules	Number of Parametric Rules
Set #1: Rules for the configuration of the ground (G)	13
Set #2: Rules for the configuration of the building (B)	7
Set #3: Rules for the configuration of the columns (CL)	33
Set #4: Rules for the configuration of the core (CO)	7
Set #5: Rules for the configuration of the plinth (P)	4
Total number of parametric rules	76

Set #1: Rules for the Configuration of the Ground (G)

The first set of the grammar (G) starts on (0,0, -1) with a labelled point that represents the lower left corner (G1). The ground vertices are labelled as (G1, G2, G3, G4) on the X and Y axis. The distance from G1 to G2 is 14 m and G1 to G4 is 14 (Figure 4.32).

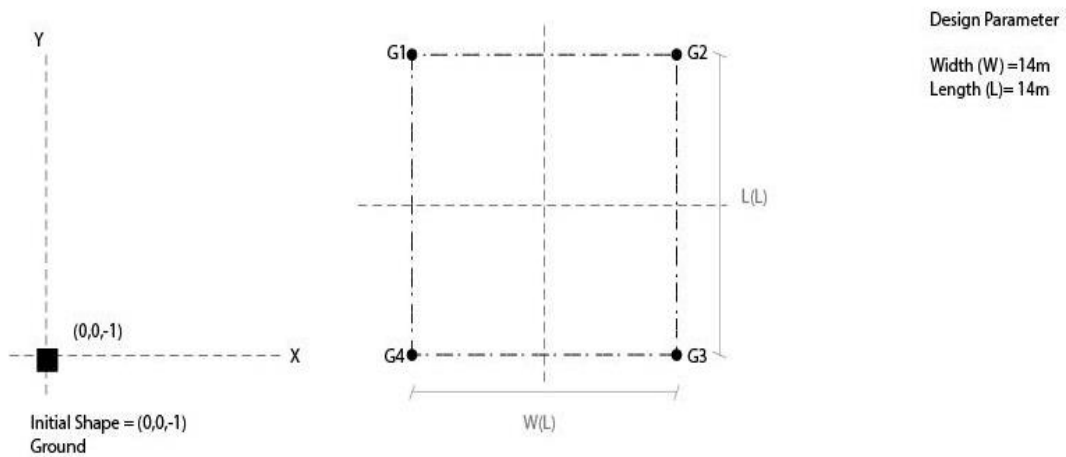

Figure 4.32: Ground (G) design parameter rules

Chapter 4: Analysis and Synthesis of Building and Ground Relationship

Applying the ground rule means one of the following types of ground will occur: flat ground, sloped ground, or level ground:

a. Flat Ground (FG)

Flat ground has one fixed highest of one m. The initial starting point, G1, is set at (0,0,0). In this case, the distance between G1 and G4 is one metre, which is the height of the ground. The ground is fixed at fourteen metres in width and length (Figure 4.33).

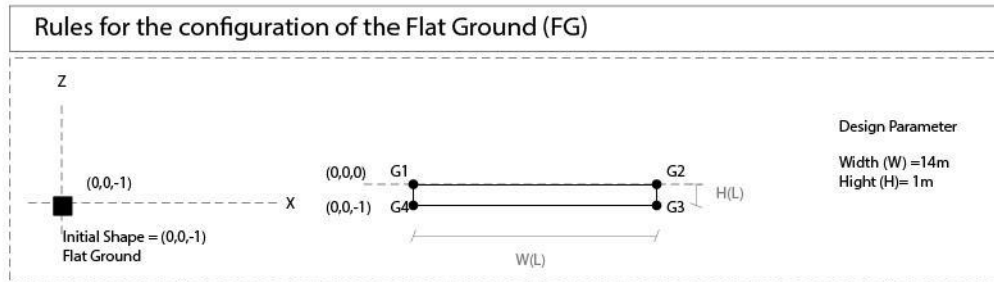

Figure 4.33: Parametric rules for the configuration of Flat Ground (FG)

b. Sloped Ground (FG)

Sloped ground has three different rules. All the rules have the same height from G2 to G3, which is one metre. However, on the other side of the ground, there are three different heights: two metres, three metres and four metres. Fixed width and length are established for the ground (Figure 4.34).

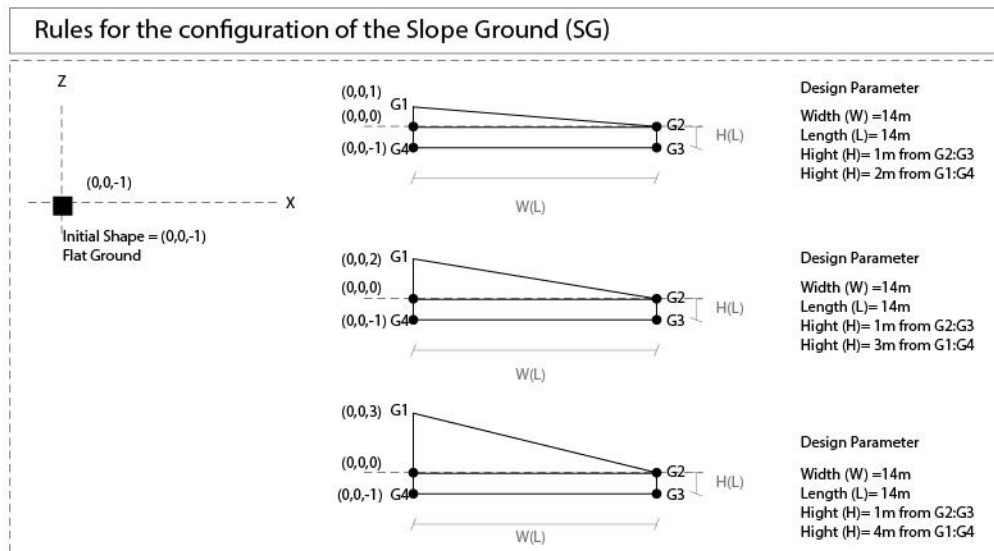

Figure 4.34: Parametric rules for the configuration of Sloped Ground (FG)

c. Level Ground (LG)

The level ground has nine different rules. All the rules have the same height from G2 to G3, which is one metre. However, the other side of the ground (G4 to G5) has three heights: two,

Chapter 4: Analysis and Synthesis of Building and Ground Relationship

three and four metres. The width and length of the ground (G4 to G3) are fixed to fourteen metres. The one-level step width changes to three different iterations (G5 to G6) can be nine, seven or five metres (Figure 4.35).

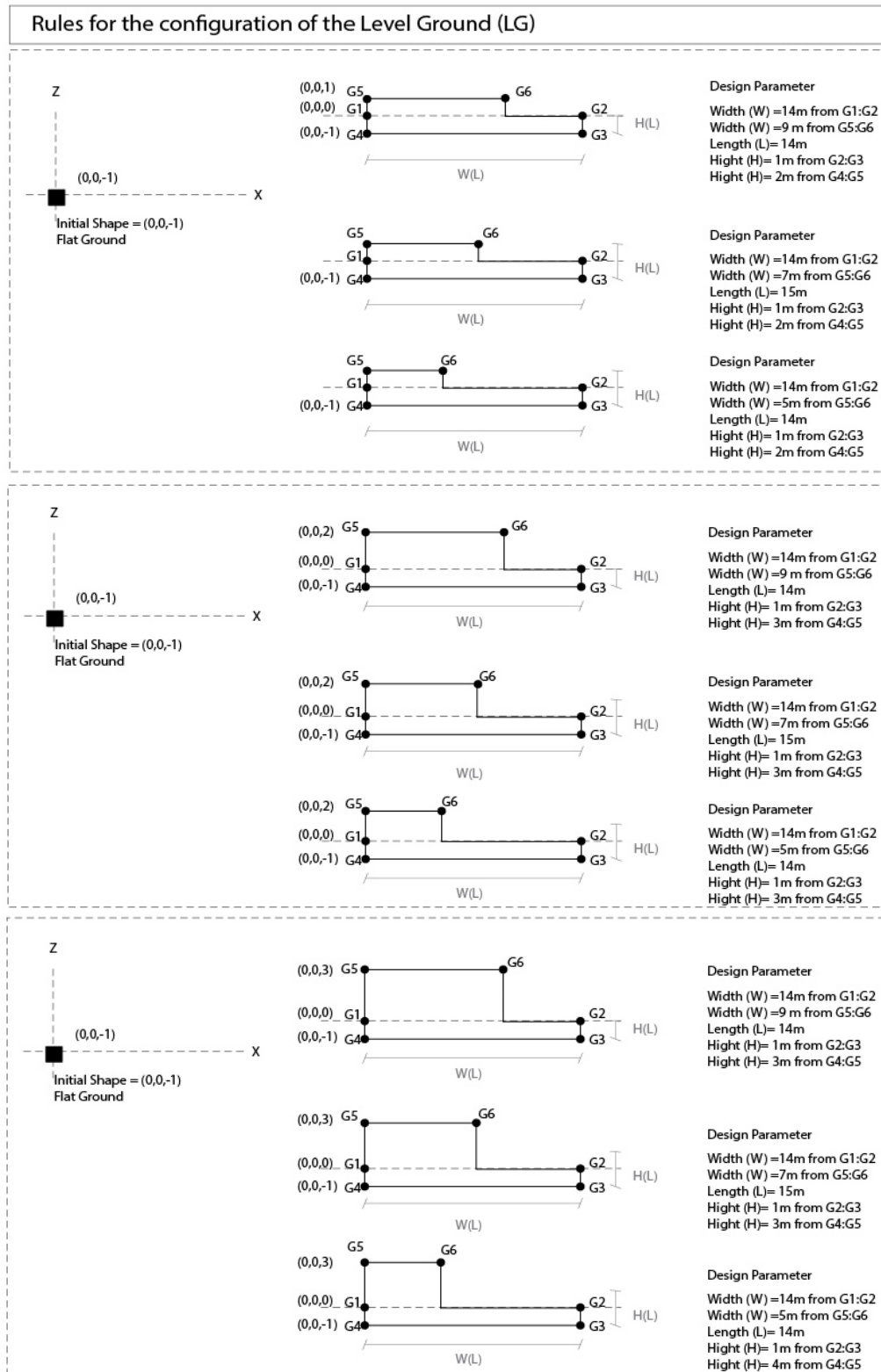

Figure 4.35: Parametric rules for the configuration of Level Ground (LG)

Set #2: Rules for the Configuration of the Building (B)

Due to the building rule, there will be either a small building, a medium building, or a large-area building. A small building has a width of six metres by a length of six metres, a medium building has a width of six metres by a length of twelve metres horizontally and vertical width of six metres by a length of twelve metres vertically. The large-area building is twelve metres by twelve metres. Each of these four forms has three variations in height, namely three, six or nine metres (Figure 4.36). A total of seven building rules starts at the initial point of (1,1,0).

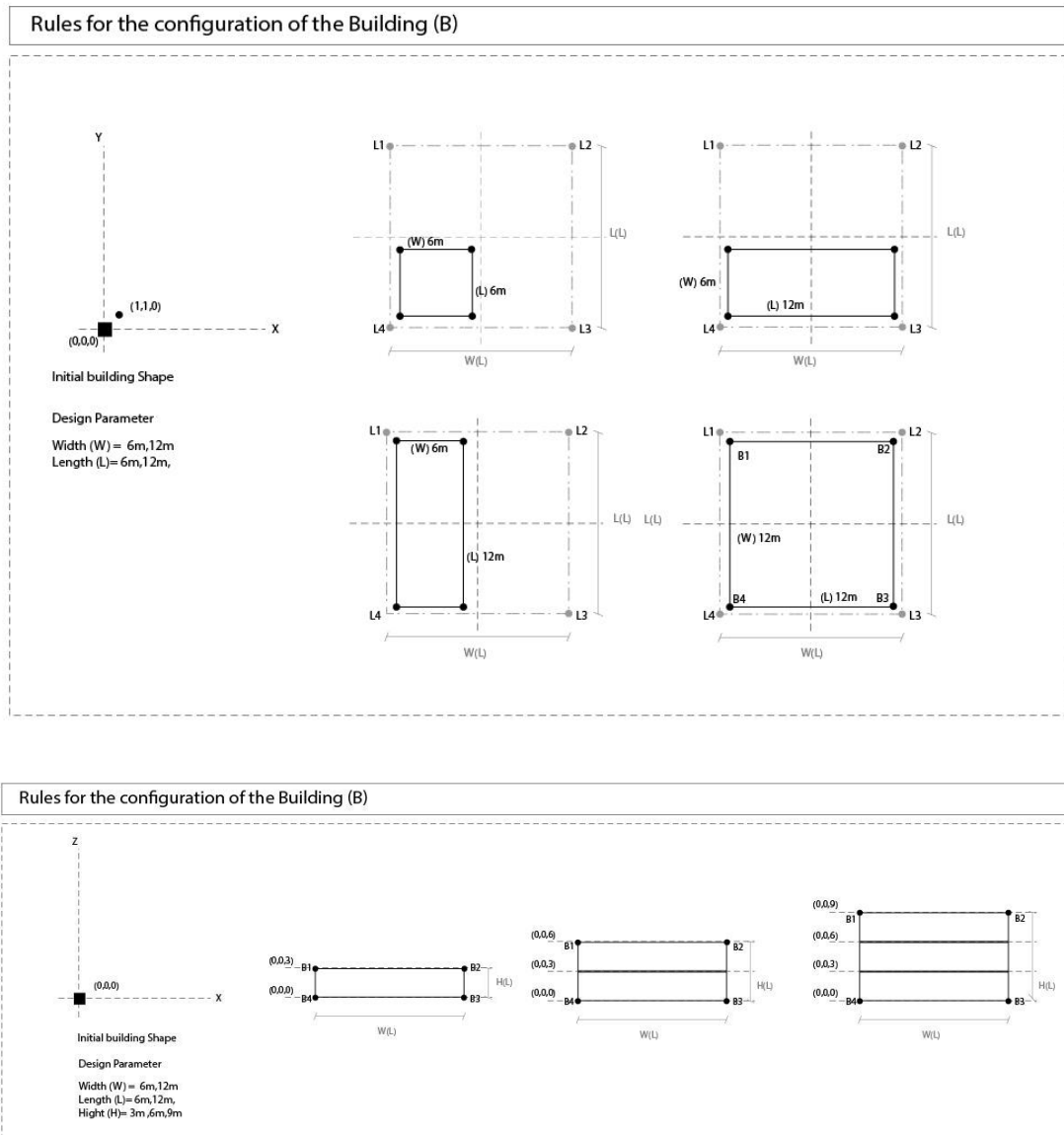

Figure 4.36: Parametric rules for the configuration of the building (B)

Chapter 4: Analysis and Synthesis of Building and Ground Relationship

Set #3: Rules for the Configuration of the Columns (CL)

The columns have three different scales: small, medium, and large. Depending on the size of the building, a grid of columns with different parameters will be applied. For example, nine small columns will be applied with one metre by one metre width to support the small building, eighteen columns of one metre by one metre width to support the medium columns and 36 columns of one metre by one metre width to support the large building. The grid rules will be applied for medium and large columns with different dimensions.

A grid of columns with a width of three metres by three metres will support the medium building. One or two columns measuring three metres by nine metres will support the medium and large buildings (Figure 4.37). Moreover, the columns have three height variants: one, two and three metres (Figure 4.38).

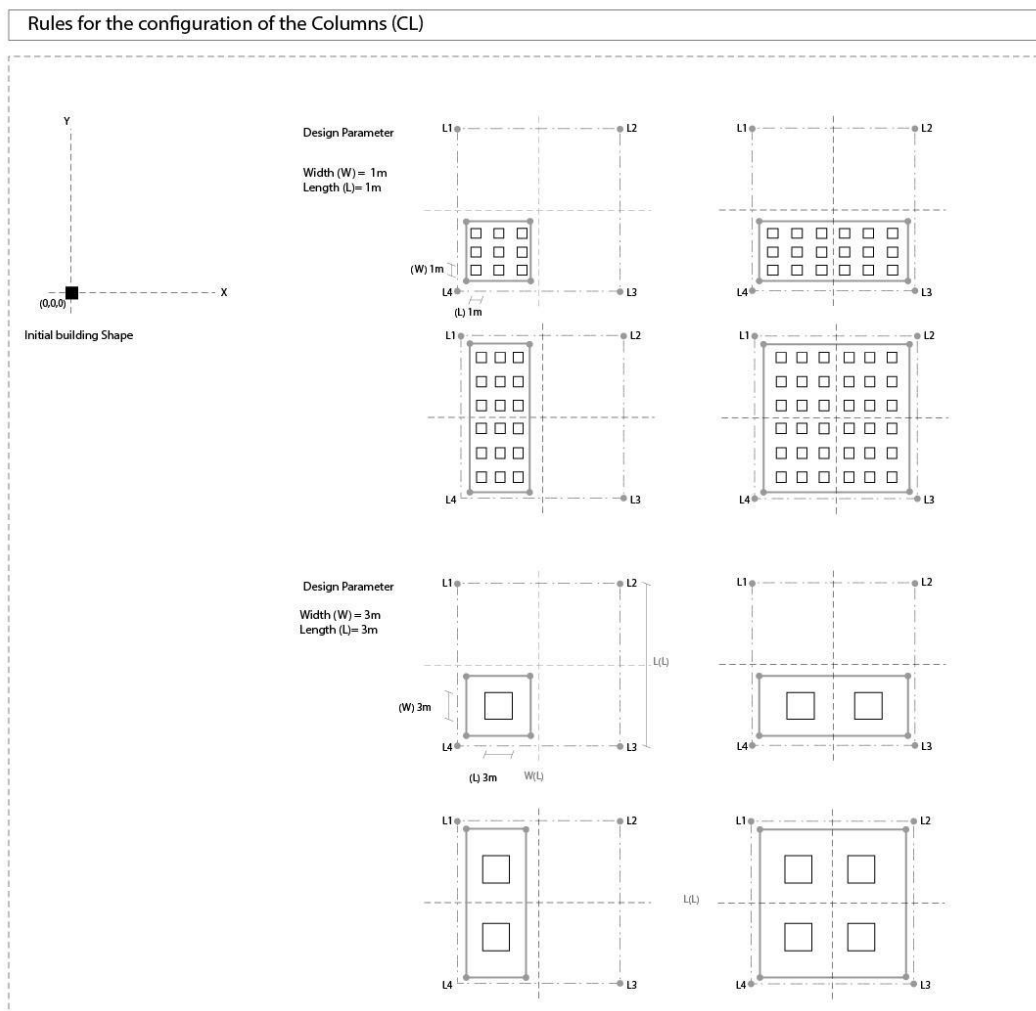

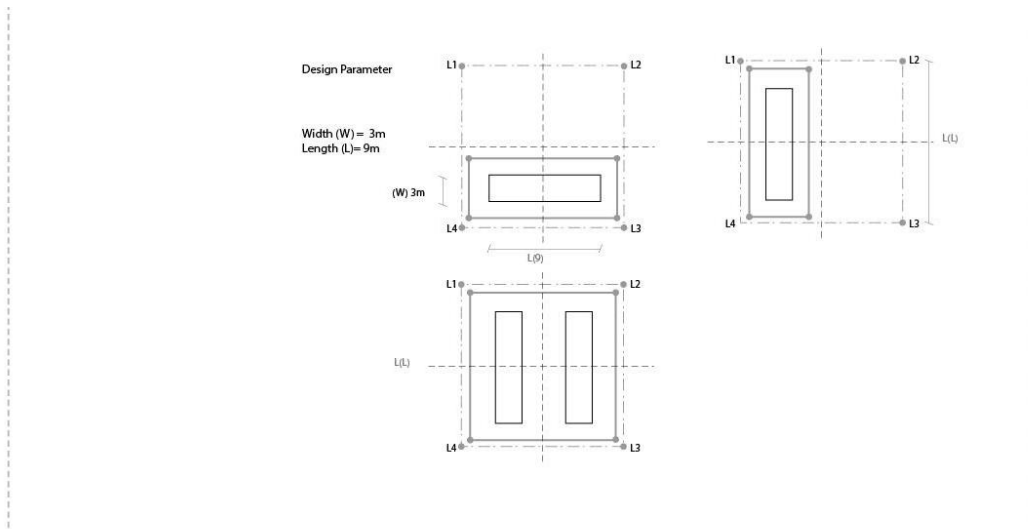

Figure 4.37: Parametric rules for the configuration of columns (CL) (Plan)

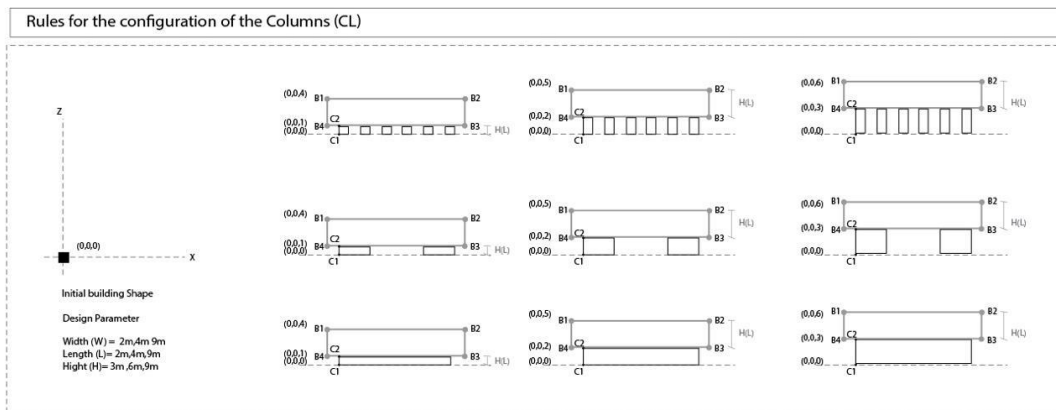

Figure 4.38: Parametric rules for the configuration of Columns (CL) (Elevation)

Set #4: Rules for the Configuration of the Core (CO)

The core has variant sizes. The core area is approximately 11% of the building area. The core starts with two metres by two metres for small buildings, two metres by four metres for medium buildings and four metres by four metres for large buildings (Figure 4.39). The core will start from the ground level and extrude with the building heights. The cores have variant heights of three, six and nine metres to match the building height (Figure 4.40).

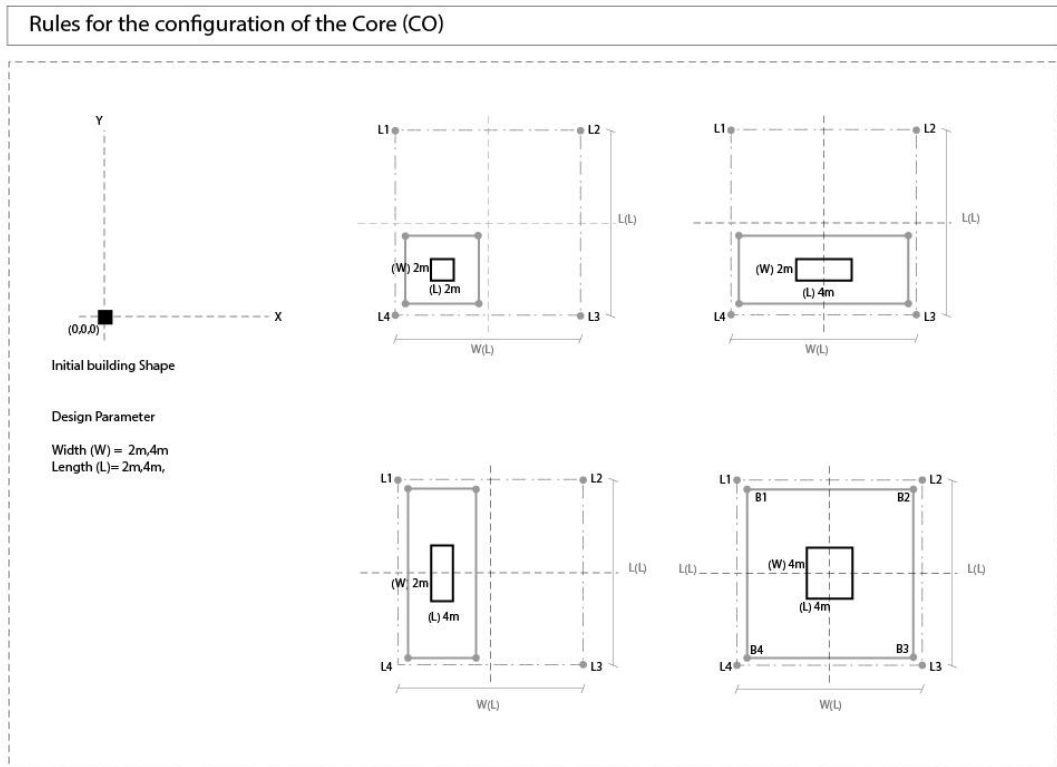

Figure 4.39: Parametric rules for the configuration of the Core (Co) (Plan)

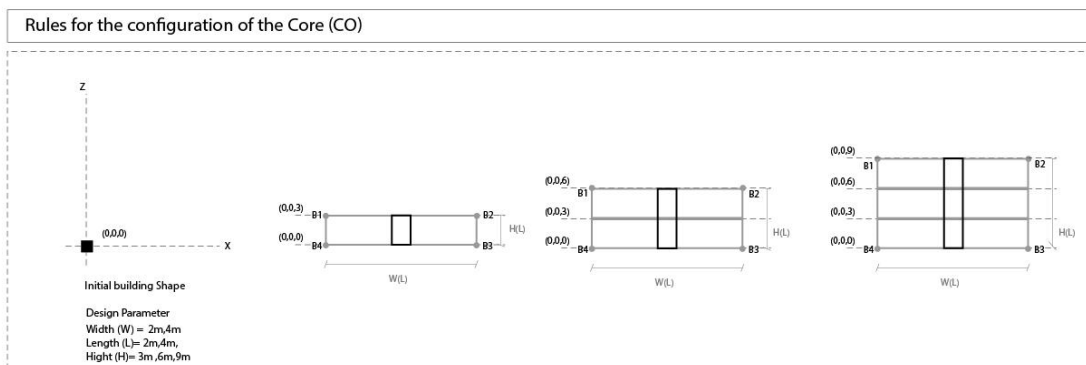

Figure 4.40: Parametric rules for the configuration of the Core (Co) (Elevation)

Set #5: Rules for the Configuration of the Plinth (P)

There are three types of plinths: small, medium, or large. Small plinths are six metres wide by six metres long, medium plinths are six metres wide by twelve metres long horizontally, and six metres wide by twelve metres long vertically. The large plinth measures twelve metres by twelve metres (Figure 4.41). The plinth height is fixed to one metre.

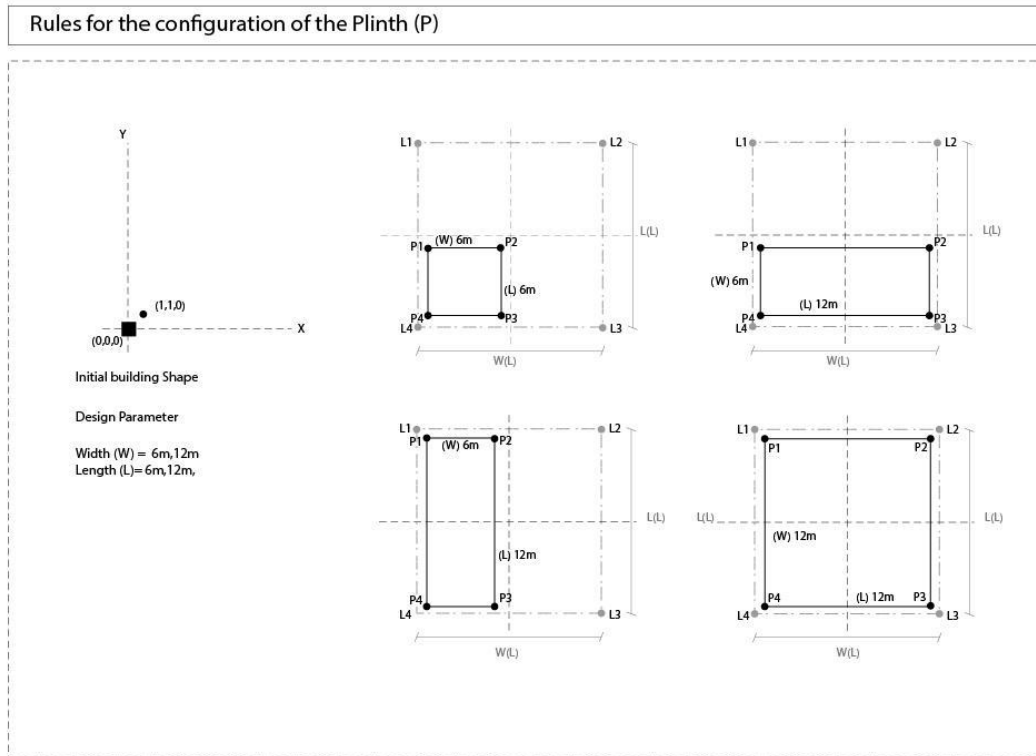

Figure 4.41: Parametric rules for the configuration of Plinth (P)

4.6. Generative 3D Topological Building and Ground Relationships

There are three forms in which data can be collected in this section, besides on the ground. The ground can be generalised into three forms: flat, sloped and level (topographical).

1. Flat Ground Generative Iterations:

The ground plate is fixed. The plinth is then dimensioned to be a certain percentage of the ground plate with equal offsets. The plinth can be 80%, 40% or 20% of the ground area; however, the plinth height is fixed. The building geometries are then placed with appropriate offsets and spacing. For the separation relationship, the columns exist to separate the building from the ground. The columns are diverse with three forms: small, medium, and large. All column forms are set within the building and plinth dimension. The column's height is also diverse with one, two or three units. The building width is varied, and it follows the plinth dimension. There are different heights of buildings, either one floor, two floors, or three floors. However, all buildings maintain the same height, which is not more than twelve metres. Finally, the building geometries are subdivided internally into a grid of cells.

2. Sloped Ground Generative Iterations:

The ground plate is varied. One of the ground plate edges is fixed, and the opposite side is changeable to three heights: two metres, three metres, and four metres. The plinth is then

dimensioned to be a certain percentage of the ground plate with equal offsets and a similar slope. The plinth, building and columns have similar rules and iterations as mentioned in the flat ground.

3. Level Ground (Topographical ground) Generative Iterations:

The ground plate is varied. One of the ground plate edges is fixed and the opposite side is changeable to three heights: two metres, three metres, and four metres. The plinth is then sized to be a certain percentage of the ground plate with equal offsets and a similar slope. The plinth, building and columns have similar rules and iterations as mentioned in the flat ground.

4.6.1. A Workflow for Generating Various 3D Parametric Models Using the Visual Programming Language and Environment "Grasshopper"

Due to the parametric nature of the constructed grammar, each derivation process produces a different solution, making it tricky to manage the process. Designers also strive to convey their ideas physically and to deliver an accurate and precise resolution within a short period (Segers et al. 2001). Therefore, the grammar has undergone translation into a computational interface and is coded using "Rhino 3D" software with its "Grasshopper", "Topologic" and "Colibri" plugins, and Python custom script in Grasshopper.

4.6.1.1. Implementation Strategy

In this research, creating a dataset requires completing three tasks. The first task was to create the objects. The objects included ground, plinth, columns, building, and cores geometries. The geometries were then subdivided internally into grids of Cells. The next step focused on two key features of the proposed workflow: 1) the automatic derivation of 3D topological dual graphs using the Cell, CellComplex and Graph classes, and 2) the embedding of semantic information through custom dictionaries. A CellComplex comprises enclosed 3D spatial units (Cells) that share Faces. Cells that share Faces are called adjacent Cells (Figure 4.42, left). Graph class and associated methods are based on graph theory. A Graph is composed of Vertices and Edges that connect Vertices to each other. A Graph accepts as input any Topology with additional optional parameters and outputs a Graph. In its simplest form, the dual graph of a CellComplex is a Graph that connects the adjacent Cells with a straight Edge (Figure 4.42, right).

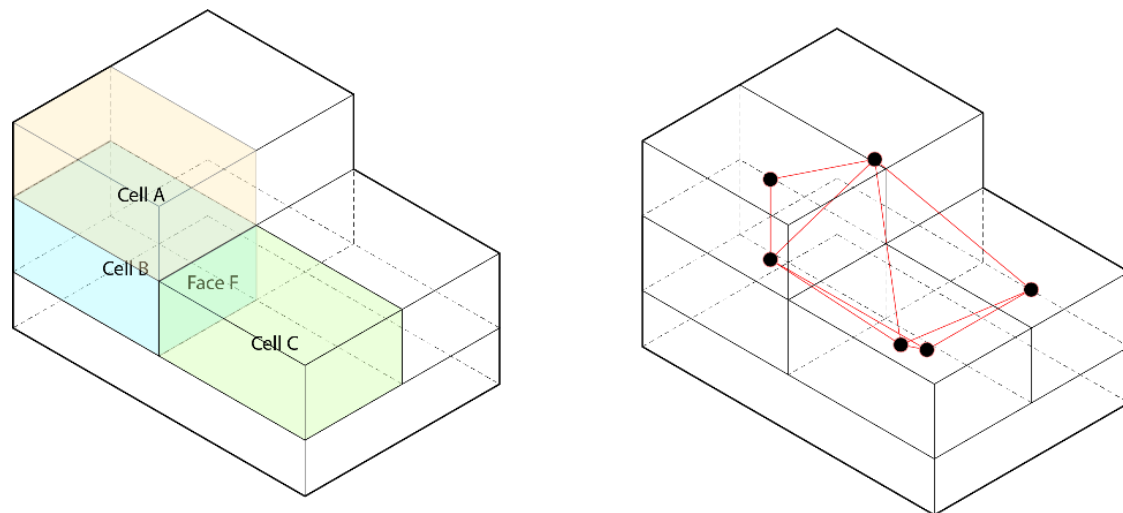

Figure 4.42: Left: an example CellComplex. Cell A and Cell B are said to be adjacent because they share Face. Figure 4.42 Right: an example dual graph of the CellComplex. Each Cell is represented by a Vertex and the Vertices of adjacent Cells are connected by an Edge

The second task was to label both the overall graph and the vertices. A dictionary is a data structure made of key/value pairs. A key is any identifying string "ID". The value of a key can be of any data type, such as "an integer" (in our workflow were "0" for the Ground, "1" for the Plinth, "2" for the Columns, "3" for the building and "4" for the Core). This approach enables the embedding of arbitrary dictionaries in any topology. Furthermore, when a dual graph is created from a topology, the dictionaries of the constituent topologies are transferred to their corresponding vertices. We use this capability to label the vertices in the dual graph. Therefore, the vertices were labelled according to five categories: 0) Ground, 1) Plinth, 2) Columns, 3) Building and 4) Core. The final task involved integrating the visual definition with a custom Python script to convert the 3D dual graph into a text file according to DGCCN format requirements.

4.6.1.2. Code Flowchart and the User Interface

The form generation process consists of three primary steps: (a) conditions and parameters (inputs); (b) the generative mechanism (rules and algorithms); and (c) the results (outputs). Based on a finite set of inputs, this mechanism executes a set of rules and actions to fulfil a defined purpose, and finally produces the result or results as outputs (Dino 2012). The following section illustrates the code flowchart that includes these components to generate a building and ground relationship dataset. The process involved five stages. It started with creating the geometry, then slicing the generated geometry using vertical and horizontal carving tools, transferring the geometry to the topology, and implementing the graph into the created topology with the Topologic tool. To run the iterations, a Python script associated with

Chapter 4: Analysis and Synthesis of Building and Ground Relationship

Colibri (Grasshopper plugin) was used. Lastly, for output results, a Text file was generated for each iteration. These text files were formatted according to the machine learning requirements (Table 4.).

Table 4.7: The three primary steps of the generation process

Generation process	Stages of design	Stages of design	
(a) Conditions and parameters (inputs)	STAGE 1	A. The allowable built-up area for the building	
		B. Generating ground objects (G)	
		C. Generating a plinth “base” object (P)	
		D. Generating columns objects (CL)	
		E. Generating a vertical circulation core (VC)	
		F. Generating building objects (B)	
(b) The generative mechanism (rules and algorithms)	STAGE 2	G. Vertical slicing G1. Vertical ground slicing (VGS) G2. Vertical plinth slicing (VPS) G3. Vertical building slicing (VBS)	
		H. Horizontal slicing H1. Horizontal ground slicing (HGS) H2. Horizontal columns slicing (HCLS) H3. Horizontal building slicing (HBS)	
		I. Ground geometry > Topological (G)	
	STAGE 3	J. Plinth geometry > Topological (P)	
		K. Columns geometry > Topological (CL)	
		L. Core geometry > Topological (CO)	
		M. Building geometry > Topological (B)	
		N. Topological Graph	
	STAGE4	O. Python Script	
		P. Colibri	
	(C) Results (Output)	STAGE5	Q. Text File
			R. Visualising and rendering

a. Input Parameters

Grasshopper, by McNeel and Associates, is a visual scripting tool that helps the design process and allows input data to be passed from one component to another via connecting wires. The interface is structured interactively, where the designer can modify a total of 76 unique parameters.

Stage 1. Generating the Geometry

The geometry of the building and ground was generated in accordance with the rules described in (Section 4.5). The first step involved calculating the allowed build-up area of the site. Afterwards, the ground requires preparation, and the building, plinth, columns, and core are constructed within the permitted building area.

Chapter 4: Analysis and Synthesis of Building and Ground Relationship

A. Generating the Allowable Built-up Area for the Building

To determine the building's allowable built-up area, it is first necessary to specify the width and length (Table 4.). The upper limit for each value is fixed at fourteen metres. The coordinate for the starting point of the layout is specified as (-1, -1, -1) (Figure 4.43).

Table 4.8: Generating allowable built-up area objects parameters

Parameters for the allowable built-up area for the building	Domain of numeric range (Inputs)	Type of input data
Width	(Fixed 14 metres)	Fixed Integer
Length	(Fixed 14 metres)	Fixed Integer

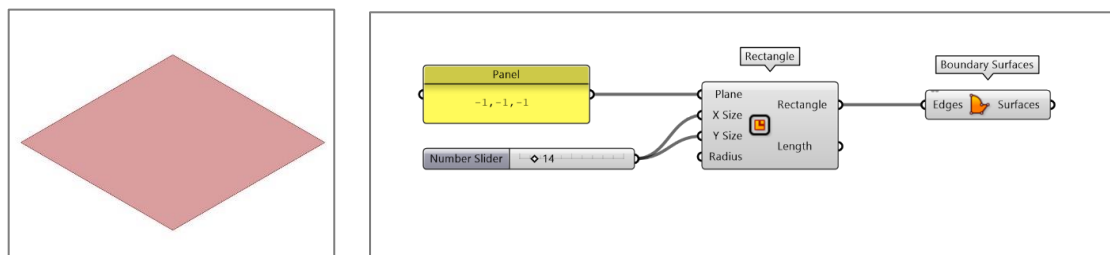

Figure 4.43: Script for generating the allowable built-up area for the building

B. Generating Ground Objects (G)

There were three parameters used in the construction of the flat ground: width, length, and height (Table 4.). This rectangle curve is fixed at fourteen metres by fourteen metres and extends by one metre in the Z direction (Figure 4.44). For the sloped ground, a similar number of parameters were used. The rectangle curve is fixed at fourteen metres by fourteen metres. However, the height of the sloped ground varies in the Z direction one, two or three metres (Figure 4.45). Finally, the level ground has a rectangle curve with a fixed width of fourteen metres and a fixed length of fourteen metres. However, on the height, there are three variations of one metre on one side and either two, three or four metres on the other (Figure 4.46).

Chapter 4: Analysis and Synthesis of Building and Ground Relationship

Table 4.9: Generating ground objects parameters

Ground parameters		Domain of numeric range (Inputs)	Type of input data
Flat Ground	Width Length Height	(14 metres) (Fixed 14 metres) (Fixed 1 metre)	Fixed Integer Fixed Integer Fixed Integer
Slope Ground	Width Length Height	(Fixed 14 metres) (Fixed 14 metres) (1 metre, 2 metres, 3 metres)	Fixed Integer Fixed Integer Slider Integer
Level Ground	Width Length Height Option 1 Height Option 2 Height Option 3	(Fixed 14 metres) (Fixed 14 metres) (1 metre, 2 metres on the other) (1 metre, 3 metres on the other) (1 metre, 4 metres on the other)	Fixed Integer Fixed Integer Slider Integer

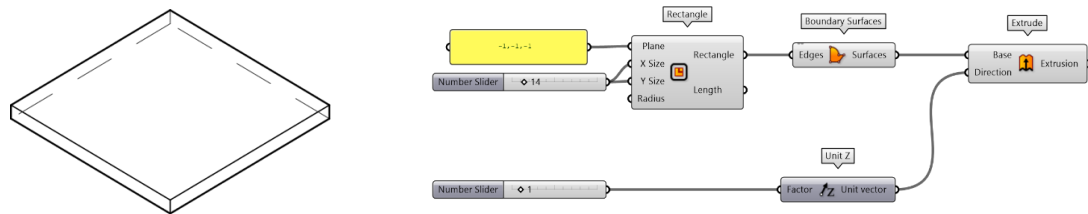

Figure 4.44: Script for generating the Flat ground (FG)

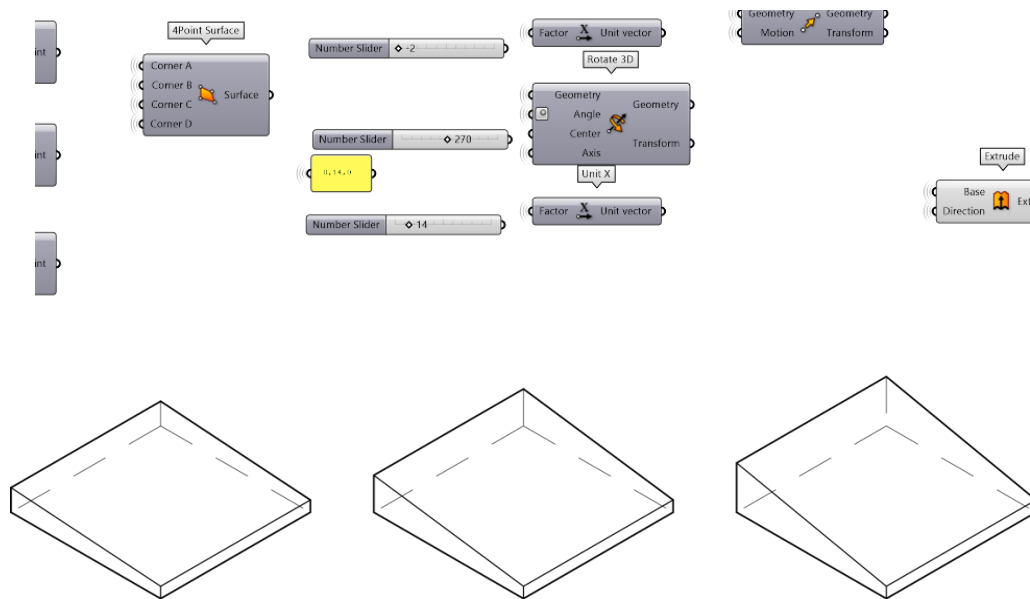

Figure 4.45: Script for generating the sloped ground (SG)

Chapter 4: Analysis and Synthesis of Building and Ground Relationship

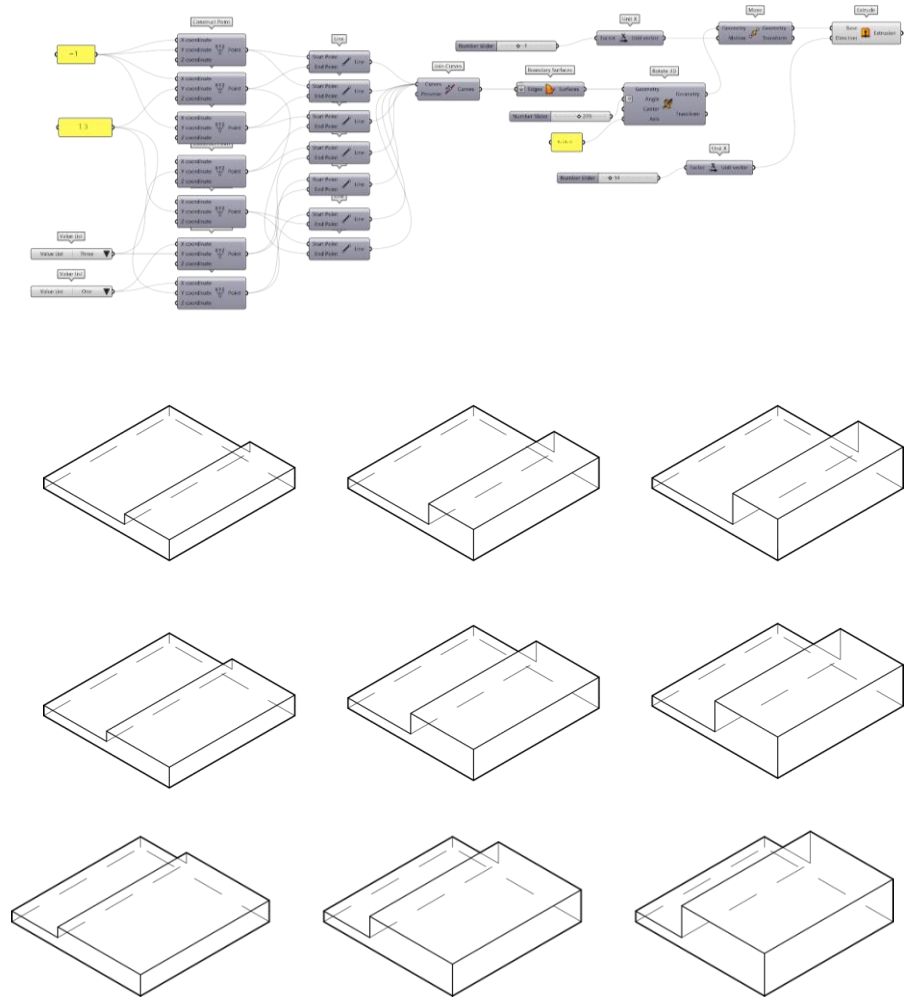

Figure 4.46: Script for generating the level ground (LG)

C. Generating a Plinth “Base” Object (P)

The plinths were designed as bases for the building objects. Plinths have three different parameters, namely width, length, and height (Table 4.). The plinths vary in width and length by six or twelve metres, but their height is fixed at one metre (Figure 4.47).

Table 4.10: Generating plinth objects parameters

Plinth parameters		Domain of numeric range (Inputs)	Type of input data
Plinth	Width	(6 or 12 metres)	Slider Integer
	Length	(6 or 12 metres)	Slider Integer
	Height	(Fixed 1 metre)	Fixed Integer

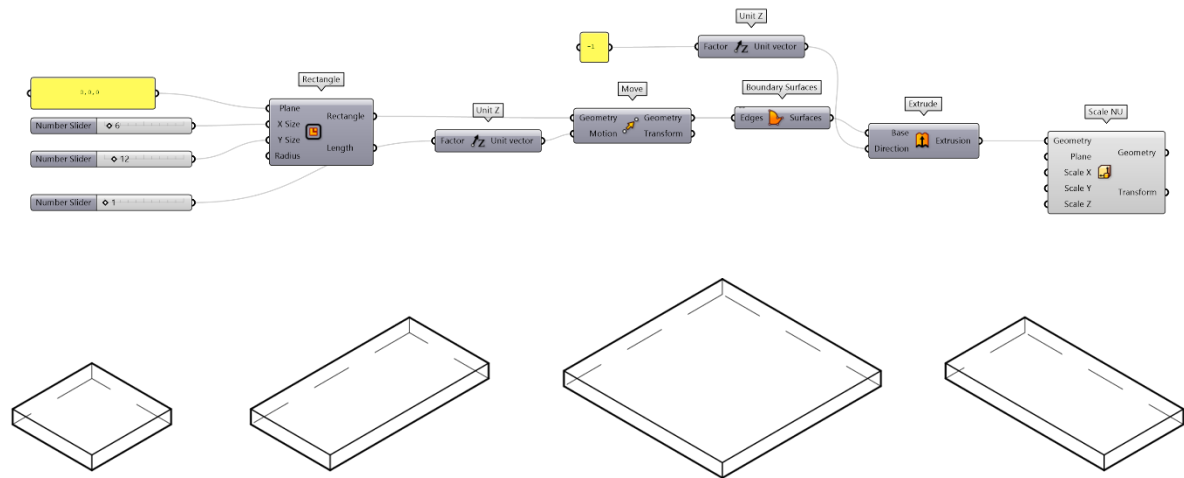

Figure 4.47: Script for generating plinth (P)

D. Generating Columns Object (CL)

The columns have three forms: small, medium, and large (Table 4.). Small and medium columns have fixed widths and lengths of one metre and three metres, respectively. Large columns vary in width and length and the slider's integer can be three or nine metres. There are, however, similarities in the height parameters of all three types of columns, which can be altered using the sliders to a height of one, two or three metres (Figure 4.48).

Table 4.11: Generating columns objects parameters

Columns parameters		Domain of numeric range (Inputs)	Number of columns in the Y and X axis	Type of input data
Small Columns	Width Length Height	(Fixed 1 metre) (Fixed 1 metre) (1, 2, 3 metres)	X axis (3, 6 columns) Y axis (3, 6 columns)	Fixed Integer Fixed Integer Slider Integer
Medium Columns	Width Length Height	(Fixed 3 metres) (Fixed 3 metres) (1, 2, 3 metres)	X axis (1, 2 columns) Y axis (1, 2 columns)	Fixed Integer Fixed Integer Slider Integer
Large Columns	Width Length Height	(3,9 metres) (3,9 metres) (1, 2, 3 metres)	X axis (1, 2 columns) Y axis (1, 2 columns)	Slider Integer Slider Integer Slider Integer

Columns S

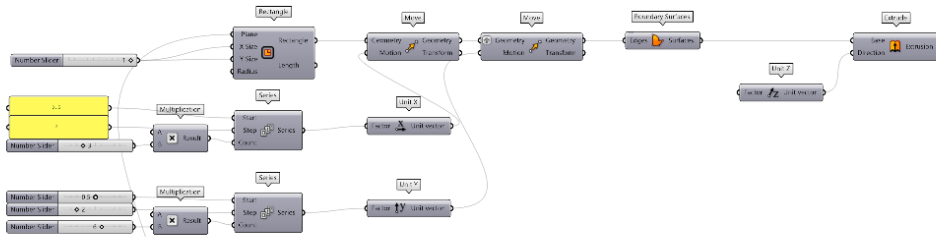

Columns M

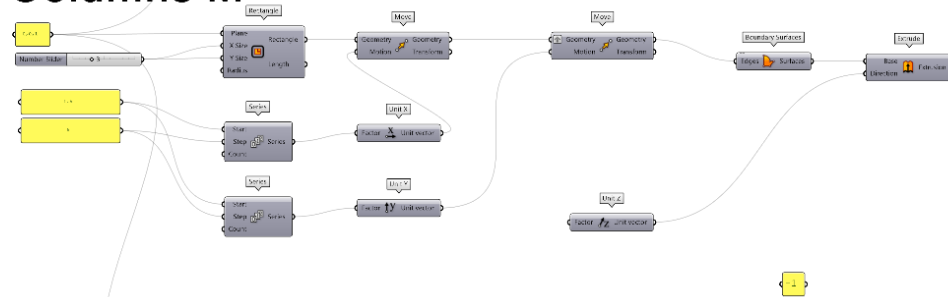

Columns L

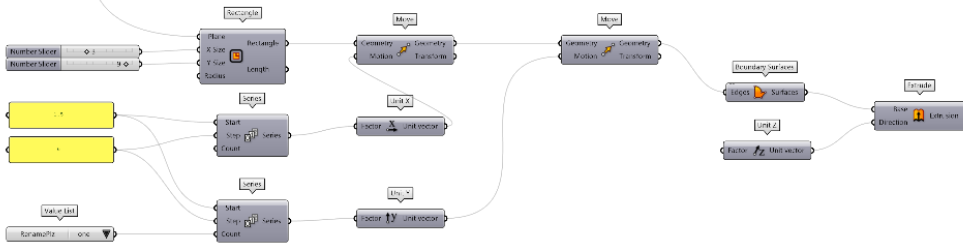

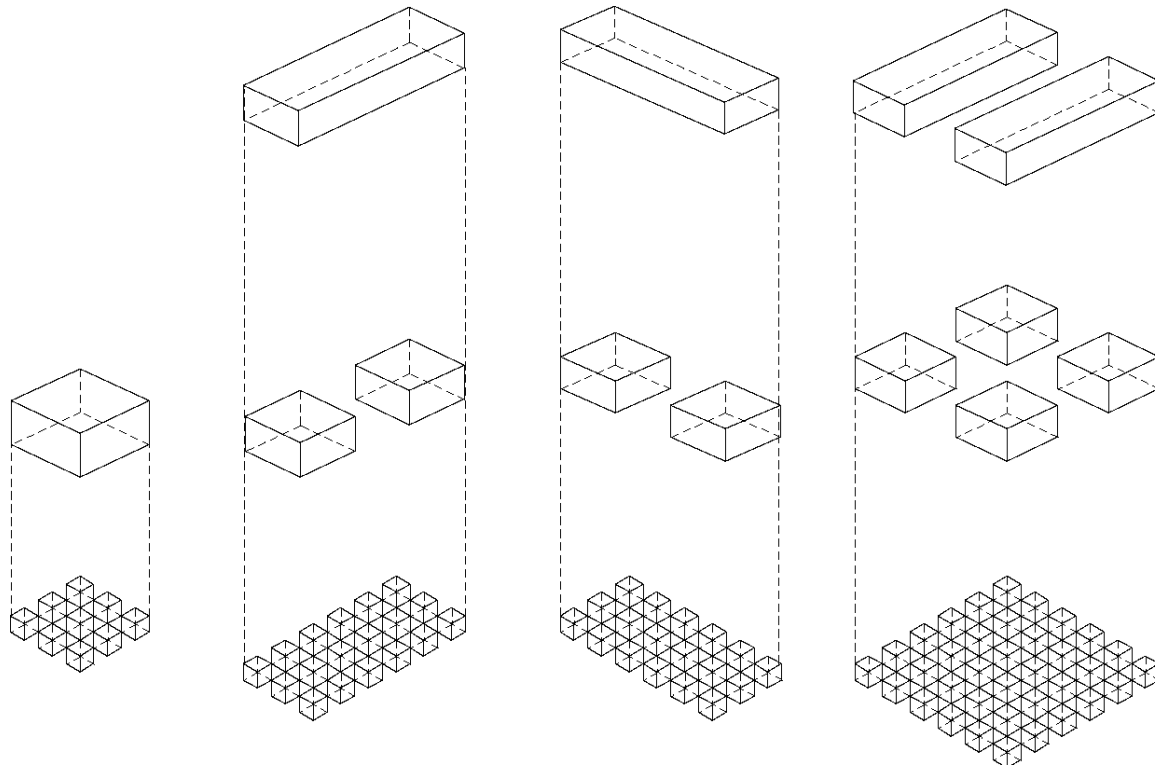

Figure 4.48: Script for generating Columns (CL)

E. Generating Vertical Circulation “Core” (VC)

The core of the building consists of vertical circulation. Starting from the ground, it passes through the building's height to reach the roof. The core has three dimensions, namely width, length, and height (Table 4.). Dimensions of the core vary in width, length, and height. The core width and length vary between two and four metres, but their height varies based on the building, so it varies between six, nine and twelve metres (Figure 4.49).

Table 4.12: Generating vertical circulation “Core” objects parameters

Core Parameters		Domain of Numeric Range (Inputs)	Type of Input Data
Core	Width	(2 or 4 metres)	Slider Integer
	Length	(2 or 4 metres)	Slider Integer
	Height	(6, 9, 12 metres)	Slider Integer

Chapter 4: Analysis and Synthesis of Building and Ground Relationship

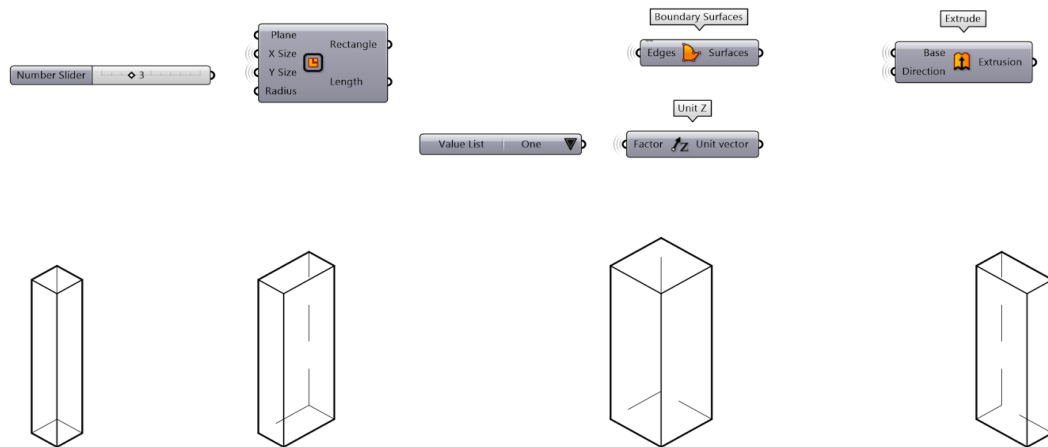

Figure 4.49: Script for generating vertical circulation "Core" (VC)

F. Generating Building Objects (B)

The building geometries were created with different width, length, and height parameters (Table 4.). The building geometry varied to six metres by six metres, six metres by nine metres, six metres by twelve metres or twelve metres by twelve metres. Moreover, the height of the building varied to one floor or two or three which are six, nine-, or twelve-meters heights (Figure 4.50).

Table 4.13: Generating Building objects parameters

Building Parameters	Domain of Numeric Range (Inputs)	Type of Input Data
Width	(6, 9, 12 metres)	Slider Integer
Length	(6, 9, 12 metres)	Slider Integer
Height	(6, 9, 12 metres)	Slider Integer

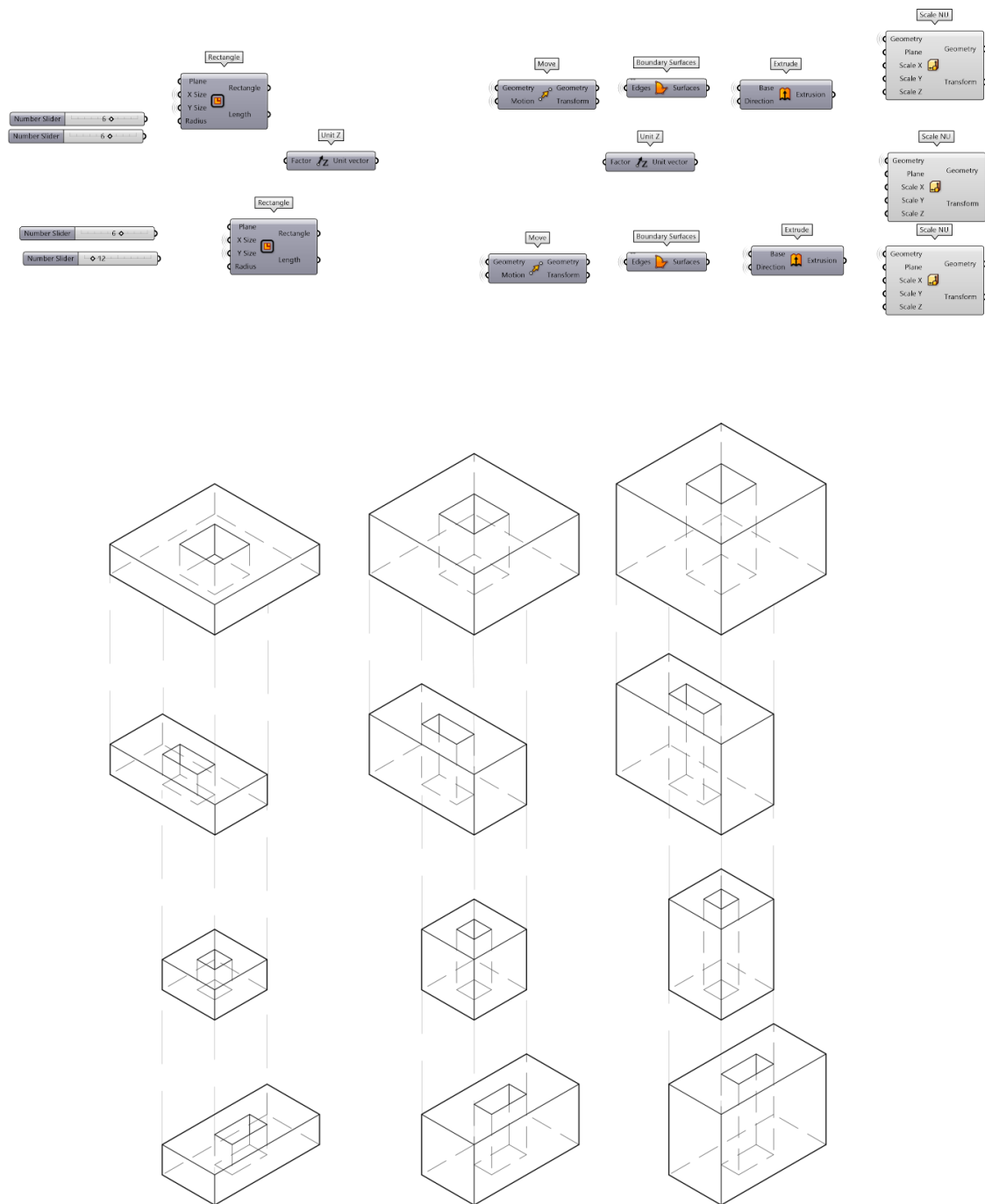

Figure 4.50: Script for generating Building (B)

Stage 2. Vertical and horizontal slicing

According to the rules in (Part B), slicing curves were created. Following the geometry types, the curves were created.

- For the *Ground and Columns geometries* (Figure 4.51), five curves slicer were created on “Unit X” and “Unit Y”, and two on “Unit Z”.

Chapter 4: Analysis and Synthesis of Building and Ground Relationship

- For the *building geometries* (Figure 4.52), five curves slicer were created on “Unit X”, “Unit Y” and “Unit Z”.
- For the *plinth geometries* (Figure 4.53), three curves slicer were created on “Unit X”, “Unit Y” and “Unit Z”.

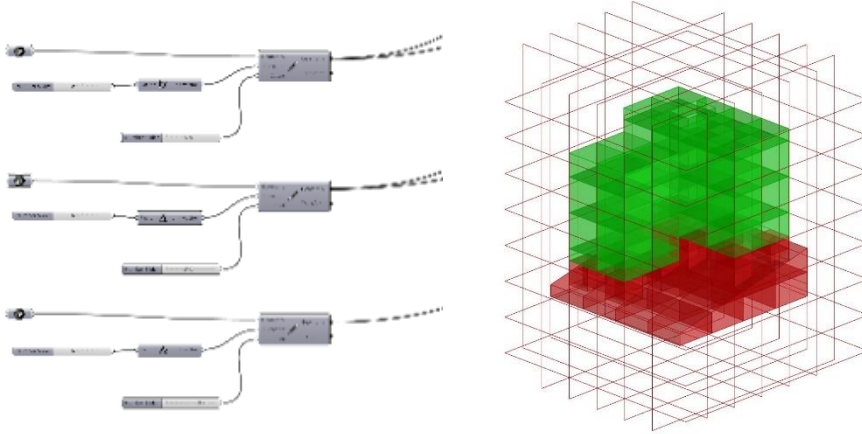

Figure 4.51: Create slicing curves for building geometries

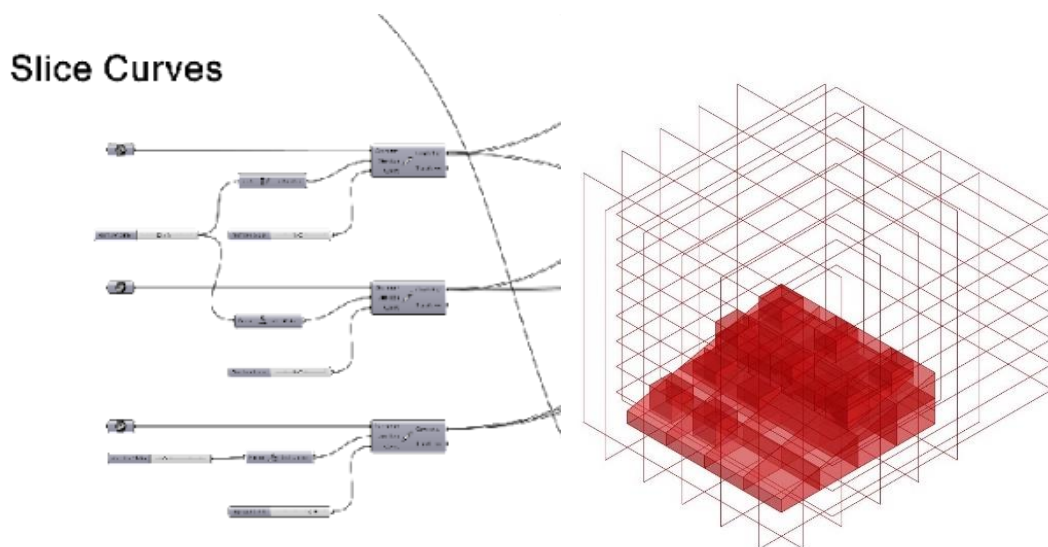

Figure 4.52: Create slicing curves for ground and columns geometries

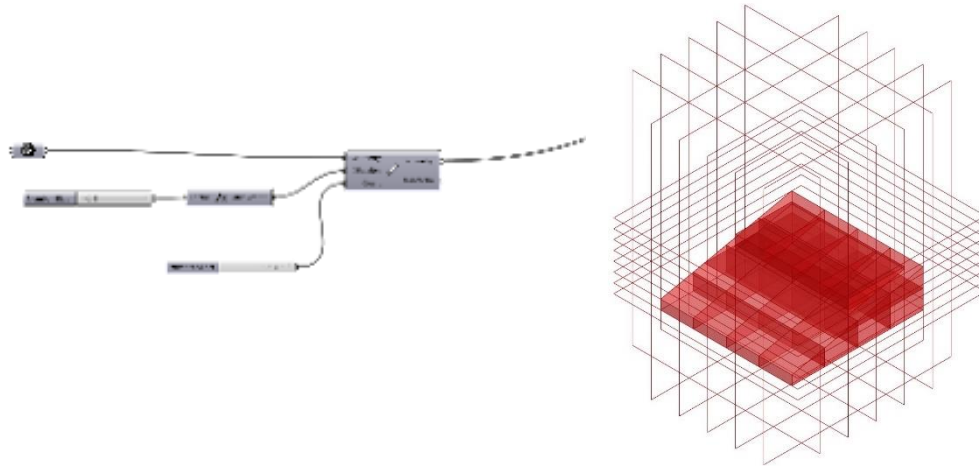

Figure 4.53: Create slicing curves for plinth geometries

Stage 3. Geometry to Topologic

In this stage, the researcher utilises the Topologic plugin to generate a topology from the geometry. All created ground, plinth, columns, core and building geometries were translated to topologies. The workflow in this stage comprised the following steps (Figure 4.54):

- In Grasshopper, for each of the five ground, building, plinth, columns and core geometries, there are five "Topology.ByGeometries" that require definition.
- All the "geometries" created in the first stage should be connected to "Topology.ByGeometry".
- Assign four "Face.ByWire" in the Grasshopper canvas, then connect "Topology.ByGeometry" to "Face.ByWire".
- Create four "Cluster.ByTopologies" in the Grasshopper canvas, then connect the "Face.ByWire" to the "Cluster.ByTopologies".
- Create another four "Topology.ByGeometries" in the Grasshopper canvas for all slice curves, then connect all the "Linear Arrays" that slice the ground to the first "Topology.ByGeometry", all the "Linear Arrays" that slice the plinth to the second "Topology.ByGeometry", all the "Linear Arrays" that slice the building to the third "Topology.ByGeometry" and all the "Linear Arrays" that slice the columns to the fourth "Topology.ByGeometry".
- Create four "Topology.Slices" in the Grasshopper canvas for the ground, building and plinth column geometries. There is no need for a "Topology.Slice" for the core geometry before connecting all the "Topology.ByGeometries" of the slicing curves to the "Topology.Slice" in the Tool input. Connect all the "Topology.ByGeometries" of the geometries to the "Topology.Slice" in the Topology input.

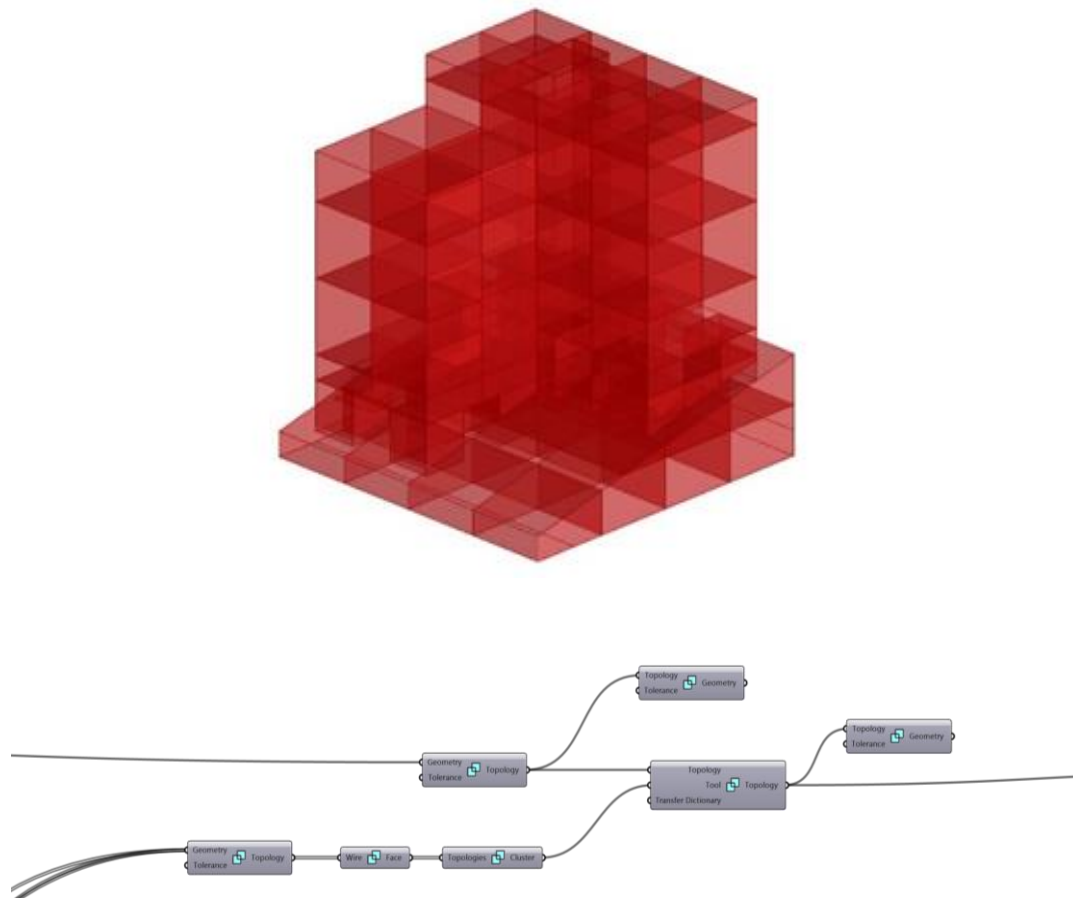

Figure 4.54: An example of converting Geometry to Topology

Stage 4.Set Dictionary

In this stage, the vertices were labelled according to five categories: ground (0), plinth (1), columns (2), building (3) and core (4). The researcher used Topologic to set the dictionary of each vertex. The workflow in this stage comprised the following (Figure 4.55).

- Create five "Topology.Cells" in the Grasshopper canvas. Then, connect the ground's "Topology.Slice" to the first "Topology.Cells", the plinth's "Topology.Slice" to the second "Topology.Cells", the column's "Topology.Slice" to the third "Topology.Cells", the building's "Topology.Slice" to the fourth "Topology.Cells" and the core's "Topology.ByGeometry" to the final "Topology.Slice".
- Create five "Dictionary.ByKeysValues" and create ten "Panel" in grasshopper canvas.
- Label five panels with the name "ID". Label the value "0" as "Ground" on one panel. Label the value "1" on one panel as the "Plinth". Label the value "2" on one panel as the "Columns". Label the value "3" on one panel as the "Building". Finally, label the value "4" on one panel as the "Core".

Chapter 4: Analysis and Synthesis of Building and Ground Relationship

- Create five "Dictionary.ByKeysValues" in the Grasshopper canvas, then connect all the "ID" to the key input of all "Dictionary.ByKeysValues", respectively. Then, connect all the "0", "1", "2", "3" and "4" panels to the value input of the "Dictionary.ByKeysValues", respectively.
- Create five "Topology.SetDictionary" in the Grasshopper canvas. Then, connect all the "Topology.Cells" to the Topology input of all "Topology.SetDictionary", respectively.
- Finally, connect all the Dictionary.ByKeysValues to the Dictionary input of all "Topology.SetDictionary", respectively.

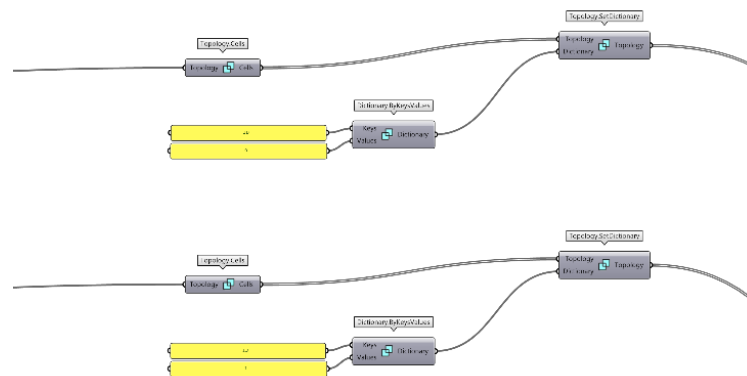

Figure 4.55: Setting the dictionary script

Stage 5. Create Topological Graph

In this stage, the topology will be merged as one cell complex and then passed to "Graph.ByTopology" to produce the final graphs. The workflow in this stage comprised the following (Figure 4.56).

- Create "Flatten Tree" in the Grasshopper canvas, then connect all the "Topology.SetDictionary" to "Flatten Tree".
- Create "CellComplex.ByCells" in the Grasshopper canvas, then connect the "Flatten Tree" to "CellComplex.ByCells" to create a cell complex.
- Create "Graph.ByTopology" in the Grasshopper canvas, then connect the "CellComplex.ByCells" to the topology input of "Graph.ByTopology".
- Create "Graph.Vertices" in the Grasshopper canvas, then connect the "Graph.ByTopology" to the *graph* input of "Graph.Vertices".
- Create "Topology.Dictionary" in the Grasshopper canvas, then connect the "Graph.Vertices" to "Topology.Dictionary".

Chapter 4: Analysis and Synthesis of Building and Ground Relationship

- Create “Dictionary.ValueAtKey” in the Grasshopper canvas, then connect the “Topology.Dictionary” to the *Dictionary* input of “Dictionary.ValueAtKey”.
 - Create “Panel” in the Grasshopper canvas, then connect the “Panel” to the “Dictionary.ValueAtKey” key input.
 - Create “Graph.Topology” in the Grasshopper canvas, then connect the “Graph.ByTopology” to the *graph* input of “Graph.Topology”.
- Create “Topology.Geometry” in the Grasshopper canvas, then connect the “Graph.Topology” to the *Topology* input of “Topology.Geometry”, then connect the “Graph.Vertices” to the *Topology* input of “Topology.Geometry”.

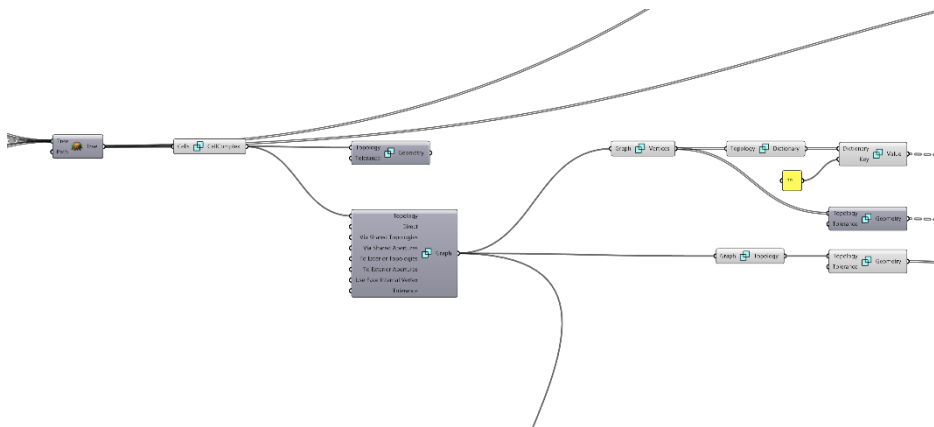

Figure 4.56: Script for creating Topological Graph

Stage 6.Create Loop and Run the Iteration

In this stage, the researcher used Grasshopper (Stream Filter) to sort all the different building and ground elements (Figure 4.57). These gates were connected to a Python script to create a loop for generating all the possible iterations (Figure 4.58).

For examples of the Stream Filter input on the separation on flat ground:

- Gate0: Separation includes ground, small columns, buildings, cores, and geometries.
- Gate1: Separation includes ground, medium columns, buildings, cores, and geometries.
- Gate2: Separation includes ground, large columns, buildings, cores, and geometries.
- Gate3: Separation with plinth includes ground, plinth, small columns, buildings, cores, and geometries.
- Gate4: Separation with plinth includes ground, plinth, medium columns, buildings, cores, and geometries.
- Gate5: Separation with plinth includes ground, plinth, large columns, buildings, cores, and geometries.

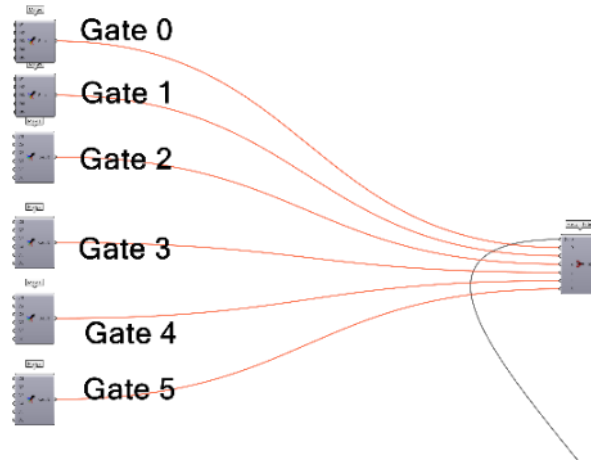

Figure 4.57: Script for creating Stream Filter

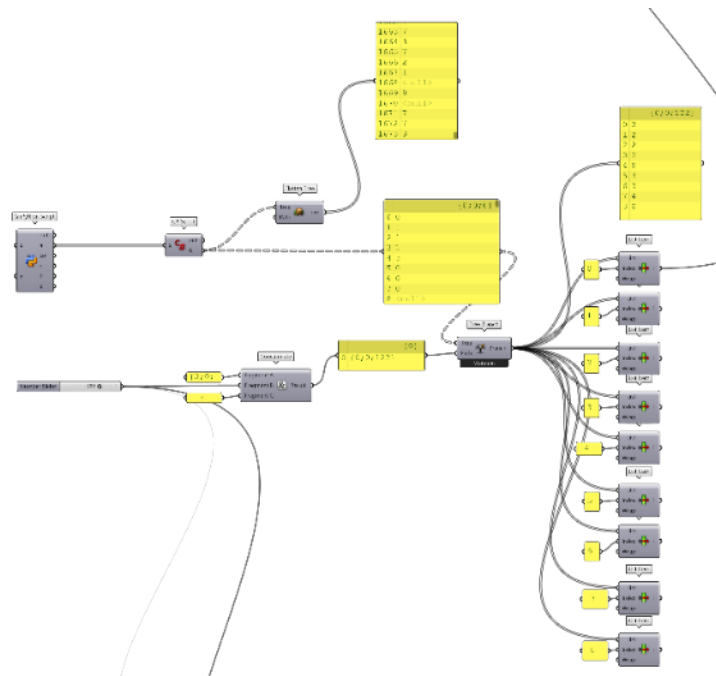

Figure 4.58: Script for creating the python loop

```

1. import rhinoscriptsyntax as rs
2. import clr
3. clr.AddReference("Grasshopper")
4. from Grasshopper.Kernel.Data import GH_Path
5. from Grasshopper import DataTree
6.
7. dataTree = DataTree[object]()
8. output = []
9. for gate in range(0,6,1):
10.     for sColumnX in range(1,3,1):
11.         if gate == 2 or gate == 5:
12.             maxY = 2
13.         else:
14.             maxY = 3
15.         for sColumnY in range(1,maxY,1):
16.             for sColumnZ in range(1,4,1):
17.                 for buildingZ in range(3,10,3):

```



```

18.         if gate == 0:
19.             co = 0
20.             r = 0
21.             b = 0
22.         if gate == 1:
23.             co = 1
24.             r = 1
25.             b = 1
26.         if gate == 2:
27.             co = 2
28.             r = 2
29.             b = 2
30.         if gate == 3:
31.             co = 3
32.             r = 3
33.             b = 4
34.             p = 0
35.         if gate == 4:
36.             co = 4
37.             r = 4
38.             b = 5
39.             p = 1
40.         if gate == 5:
41.             co = 5
42.             r = 5
43.             b = 6
44.             p = 2
45.         output.append([gate,sColumnX, sColumnY, sColumnZ, buildingZ, co, r, b, p])
46.     for gate in range(6,8,1):
47.         for buildingZ in range(3,10,3):
48.             for buildingX in range(1,3,1):
49.                 for buildingY in range(1,3,1):
50.                     if gate == 6:
51.                         r = 6
52.                         b = 3
53.                     if gate == 7:
54.                         r = 7
55.                         b = 7
56.                         p = 3
57.                 output.append([gate,sColumnX, sColumnY, None, buildingZ, None, r, b, p])
58. # Assign your output to the OUT variable.
59. a = output

```

Following this, researchers employed (Colibri Iterator) to control the number of each iteration. Further, they used the image setting to save the top, right and perspective views for each iteration (Figure 4.59).

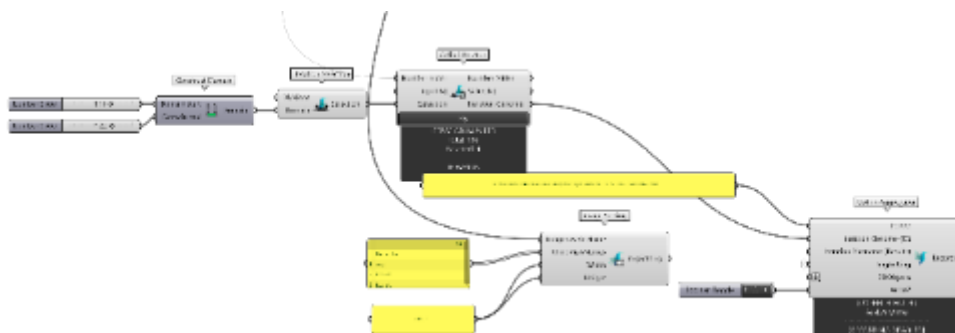

Figure 4.59: Script for creating the Colibri Iterator and save the produced views

Stage 7. Text Files

This final stage integrated the visual dataflow definition with a custom Python script to convert the 3D dual graph created by Topologic into a text file to meet the DGCNN format requirements. The workflow in this stage comprised the following:

- A **“GhPython Script”** is used in Grasshopper to write the below code. The code labels the graph as a whole and the vertices (nodes) within the graph to flag any unlabelled vertices.

```
1. import rhinoscriptsyntax as rs
2. import sys
3. import clr
4. clr.AddReference('TopologicNET')
5. import Topologic
6.
7. def vertexIndex(vertex, vertices):
8.     for i in range(len(vertices)):
9.         if Topologic.Topology.IsSame(vertex, vertices[i]):
10.            return i
11.     return None
12.
13. def vertexCategory(vertex):
14.     z = vertex.Z
15.     category = 0
16.     if z < 70:
17.         category = 0
18.     elif z < 120:
19.         category = 1
20.     else:
21.         category = 3
22.     return category
23.
24. vertices = graph.Vertices
25. if label > 3:
26.     label = 0
27. else:
28.     label = 0
29. outputString = str(len(vertices))+ " "+str(label)+"\n"
30.
31. for j in range(len(vertices)):
32.     dict = vertices[j].Dictionary
33.     vLabel = int(dict["ID"])
34.     #if vLabel == 3:
35.         #vLabel = vLabel + vertexCategory(vertices[j]);
36.     av = Topologic.Graph.AdjacentVertices(graph, vertices[j])
37.     outputString = outputString+str(vLabel)+" "+ str(len(av))+ " "
38.     for k in range(len(av)):
39.         vi = vertexIndex(av[k], vertices)
40.         outputString = outputString+str(vi)+" "
41.     if j < len(vertices)-1:
42.         outputString = outputString+"\n"
43.
44. a = outputString
```

- The second code is **“Python script (TxtWrite)”**. Connecting the Grasshopper "Toggle" and setting it to true allows the code to transfer the Grasshopper panels to a text file.

Chapter 4: Analysis and Synthesis of Building and Ground Relationship

```
1. import os
2. from scriptcontext import sticky as st
3.
4. # Add a counter variable to sticky
5. if "count" not in st or Reset:
6.     st["count"] = 0
7.
8. if Write:
9.
10. # Use the ghenv variable to get the current GH file path
11. filePath = ghenv.LocalScope.ghdoc.Path
12. fileName = ghenv.LocalScope.ghdoc.Name
13. filePath = filePath.replace(".gh", "")
14. filePath = filePath.replace(fileName, "")
15.
16. # Add file name, count and extension
17. filePath = os.path.join(filePath, Name + "_" + str(st["count"]) + ".txt")
18.
19. # Open file
20. fileWrite = open(filePath, "w")
21.
22. # Write text data to file
23. for line in Data:
24.     fileWrite.write(line + "\n")
25.
26. # Close file
27. fileWrite.close()
28.
29. # Increment count
30. st["count"] += 1
```

To summarize all the previous stages, the overall grasshopper definition of generating 3D parametric models and their associated topological dual graph is below. The grasshopper definition is an example of building ground relationships, which is separation (Figure 4.60).

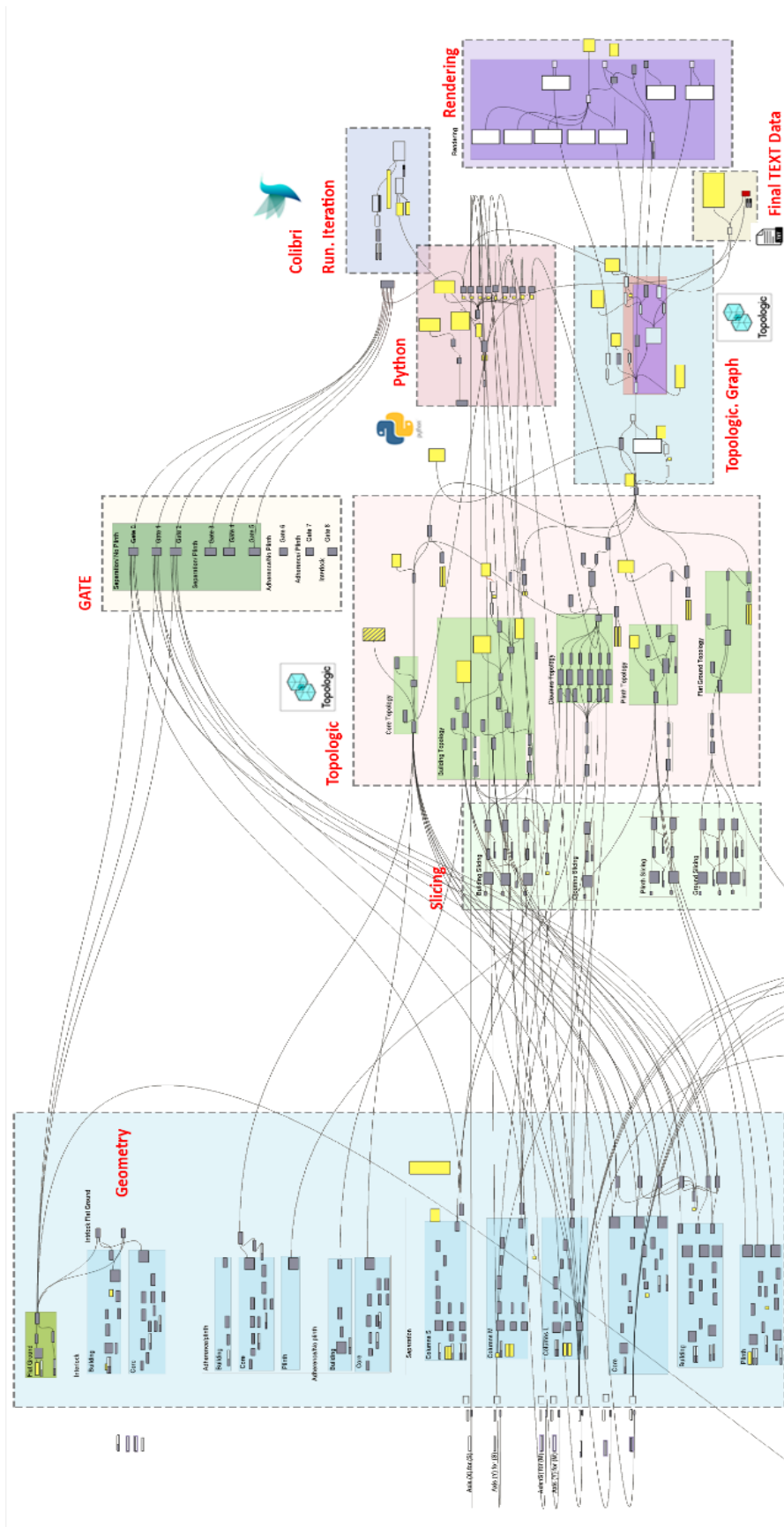

Figure 4.60: Grasshopper definition of generating 3D parametric models and their associated topological dual graph

4.6.1.3. The Required DGCNN Format

The DGCNN required a unique format. In the text file, the first line indicates the total graphs (g). Following this is g blocks of graphs, each of which contains a line indicating the number of vertices (n) and a number indicating the classification (p) of that graph. Afterwards, there is a block of n vertices, where each line begins with the label of the vertex (v_i) and continues with the index of its adjacent vertex. The index of a vertex is implied by its line position using a zero-based numbering system (Figure 4.61).

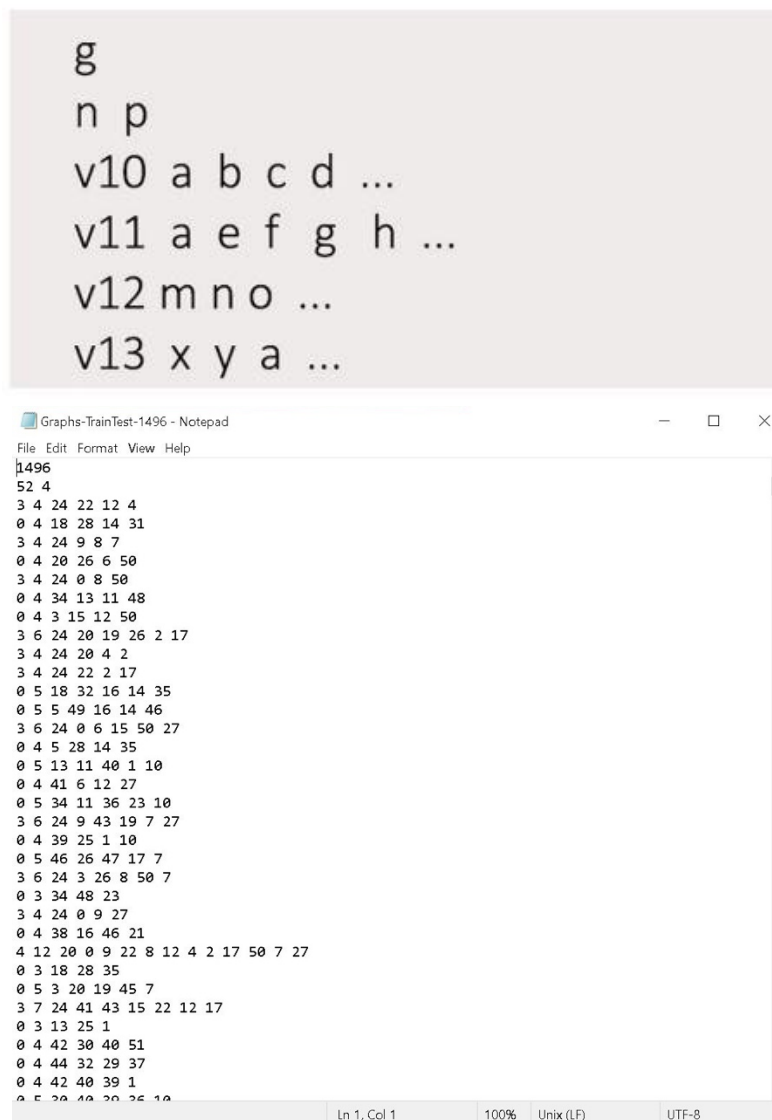

Figure 4.61: The general data set format required for DGCNN

4.6.1.4. Results of the Generated 3D Topological Building and Ground Relationship

Datasets

Consequently, the generated 3D topological building and ground relationship datasets can be summarised as follows:

1. The flat ground has three main relationship forms: separation, adherence, and interlock (Figure 4.62). This section will produce 240 iterations. For separation, the building columns can form the iterations by being either on a plinth or could be set directly to the ground without needing a plinth. This will occur from 180 building and ground separated relationship iterations. For the adherence iteration, the building could be either on a plinth or set directly to the ground. This will create approximately another 24 iterations. Finally, for the interlock iteration, the building will have one unique form to integrate with the ground, producing another 36 iterations (Table 4.14).

Table 4.14: Flat ground iterations

Ground type	Classes	Categories	No. iteration	
Flat Ground	Separation	No plinth	S columns	36
			M columns	36
			L columns	18
		Plinth	S columns	36
			M columns	36
			L columns	18
	Total			180
	Adherence	No plinth		12
		Plinth		12
		Total		24
	Interlock	With the ground		36
Total		36		
Total Flat Ground iteration			240	

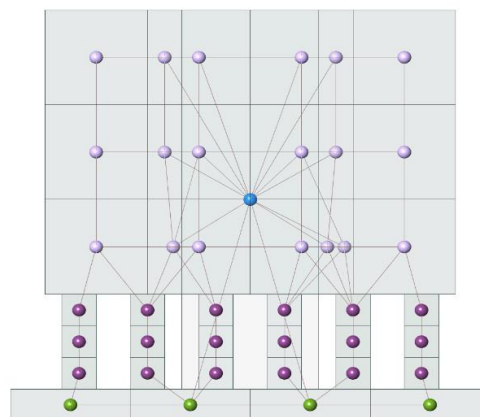
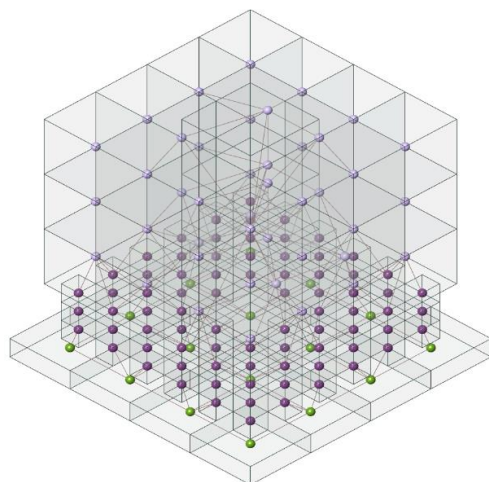

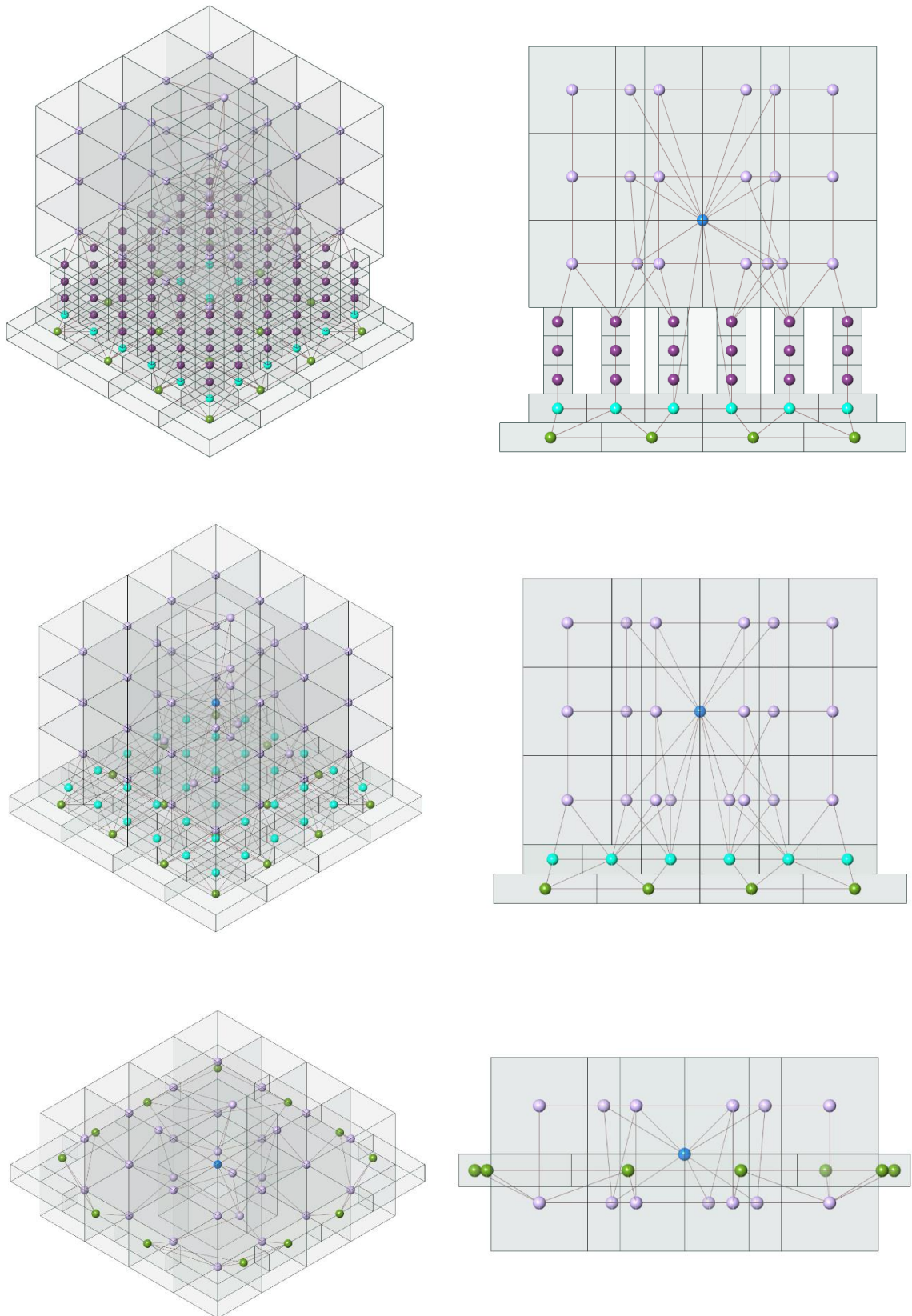

Figure 4.62: Examples of building and ground iteration on flat ground

Chapter 4: Analysis and Synthesis of Building and Ground Relationship

2. The sloped ground has three primary relationship forms: separation, adherence, and interlock (Figure 4.63). This section will produce a total of 684 iterations. For separation, the building columns can form the iterations by being either on a plinth or set directly to the ground without needing a plinth. This will occur from 540 building and ground separated relationship iterations. For the adherence iteration, the building could be either on a plinth or set directly to the ground. This will create approximately another 72 iterations. Finally, for the interlock iteration, the building will have one unique form to integrate with the ground, producing another 72 iterations (Table 4.).

Table 4.15: Sloped ground iterations

Ground type	Classes	Categories	No. iteration	
Sloped Ground	Separation	No plinth	S columns	108
			M columns	108
			L columns	54
		Plinth	S columns	108
			M columns	108
			L columns	54
	Total			540
	Adherence	No plinth		36
		Plinth		36
		Total		72
Interlock	With the ground		72	
	Total		72	
Total Sloped Ground iteration			684	

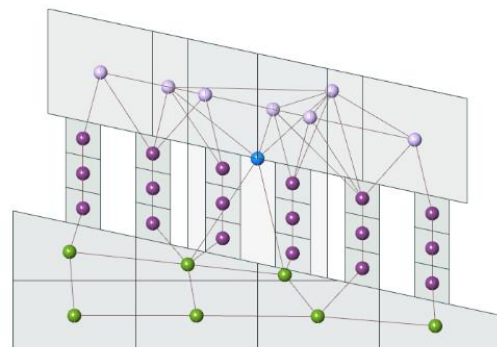
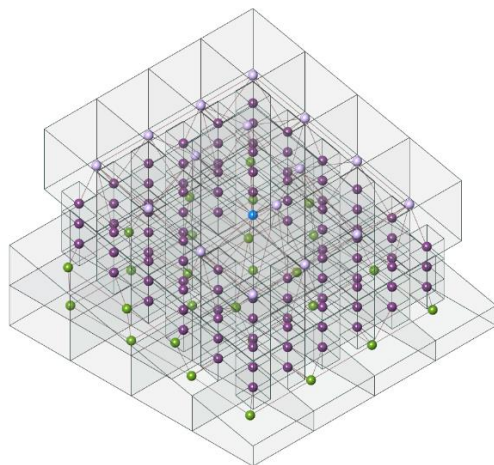

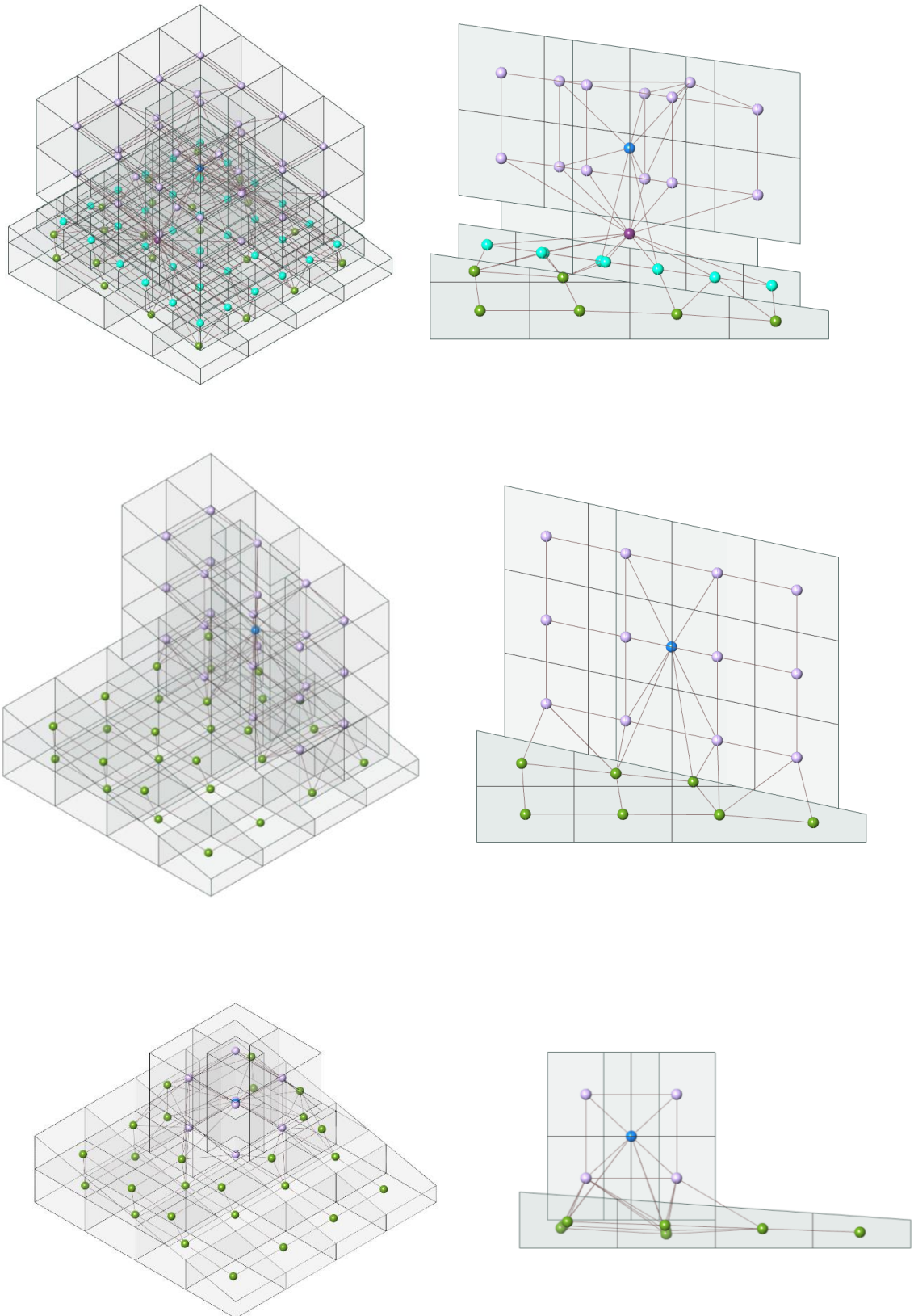

Figure 4.63: Examples of building and ground iteration on sloped ground

Chapter 4: Analysis and Synthesis of Building and Ground Relationship

3. Level ground (Topographical ground) has three main relationship forms: separation, adherence, and interlock (Figure 4.64). This section will produce a total of 1,242 iterations. For separation, the building columns can form the iterations by being either on a plinth or set directly to the ground without needing a plinth. This will be from 810 building and ground separated relationship iterations. For the adherence iteration, the building could be either on a plinth or set directly to the ground. This will create approximately another 108 iterations. Finally, for the interlock iteration, the building will have one unique form to integrate with the ground, and this will produce another 324 iterations (Table 4.).

Table 4.16: Level ground iterations

Ground type	Classes	Categories	No. iteration	
Level Ground	Separation	No plinth	S columns	162
			M columns	162
			L columns	54
		Plinth	S columns	162
			M columns	162
			L columns	54
	Total			810
	Adherence	No plinth		54
		Plinth		54
		Total		108
	Interlock	With the ground		324
Total		324		
Total Level Ground iteration			1242	

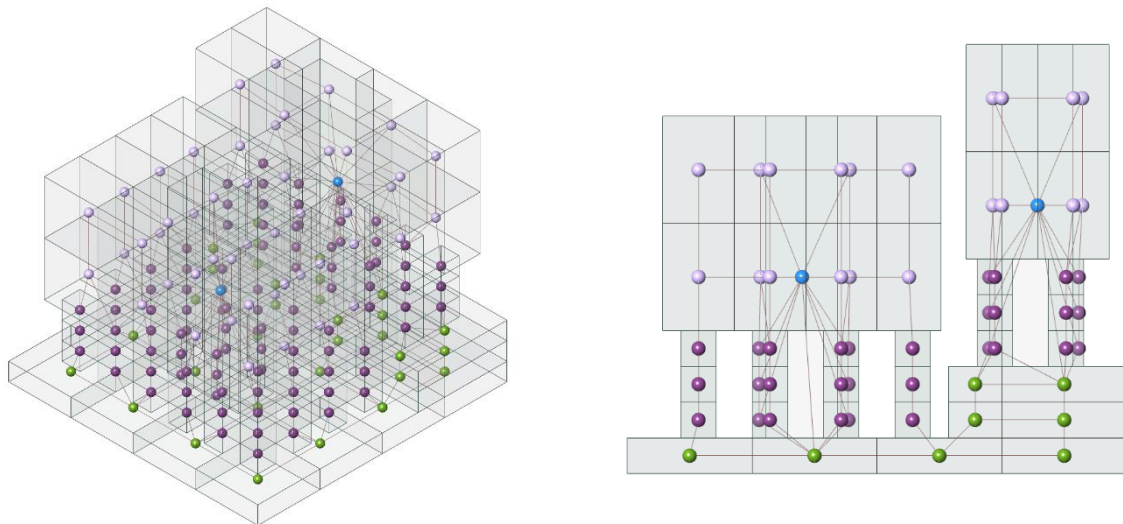

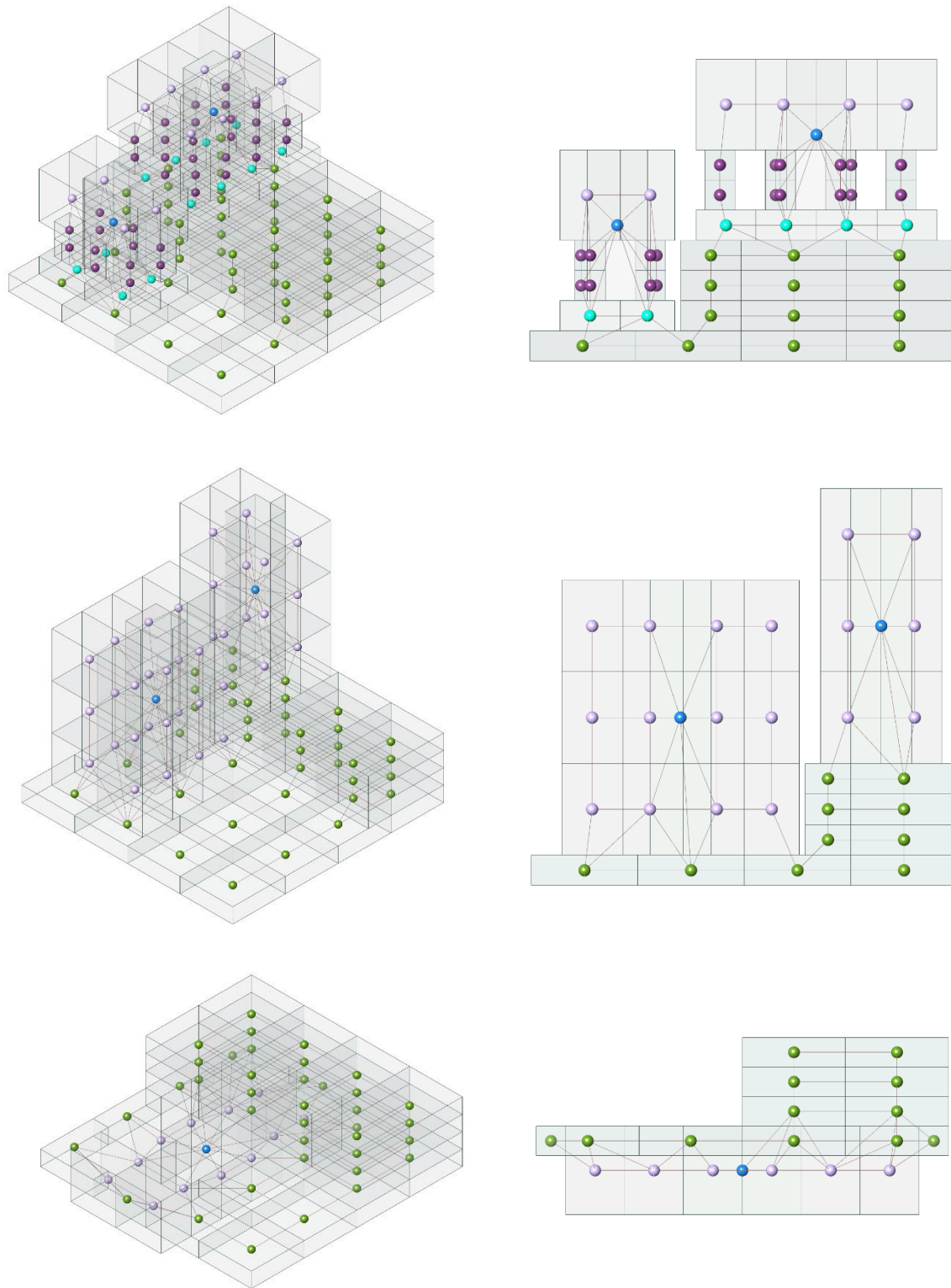

Figure 4.64: Examples of building and ground iteration on Level ground

Chapter 4: Analysis and Synthesis of Building and Ground Relationship

4.6.1.5. Errors in the Generated 3D Topological Building and Ground Relationship

This research produced 2,166 iterations of ground and building relationships, each accompanied by a dual graph. However, some of the iterations contained errors in labelling the vertices of the dual graph. However, despite the researcher's efforts to rectify the errors manually, approximately 30 iterations were eliminated to the conditions that produced the errors. The errors were primarily found in the sloped ground since some of the cells generated might be smaller than the cells that could be translated to the topology. In the sloped ground, 23 errors were found out of 30. The remaining seven were detected in the Level 1 terrain (Table 4.7).

Table 4.17: Errors in labelling the vertices of the dual graph

Flat Ground		Sloped Ground		Level Ground	
The relationship	No. Errors	The relationship	No. Errors	The relationship	No. Errors
Separation, no plinth	0	Separation, no plinth	-1	Separation, no plinth	-3
	0		0		0
	0		-2		-3
Separation plinth	0	Separation plinth	-9	Separation plinth	0
	0		-3		0
	0		-3		0
Adherence, no plinth	0	Adherence, no plinth	0	Adherence, no plinth	0
Adherence plinth	0	Adherence plinth	-5	Adherence plinth	0
Interlock	0	Interlock	0	Interlock	-1
Total	0	Total	-23	Total	-7

4.6.1.6. Examples of the Generated 3D Topological Building and Ground Relationship (Flat Ground) (Figure 4.65 to Figure 4.68)

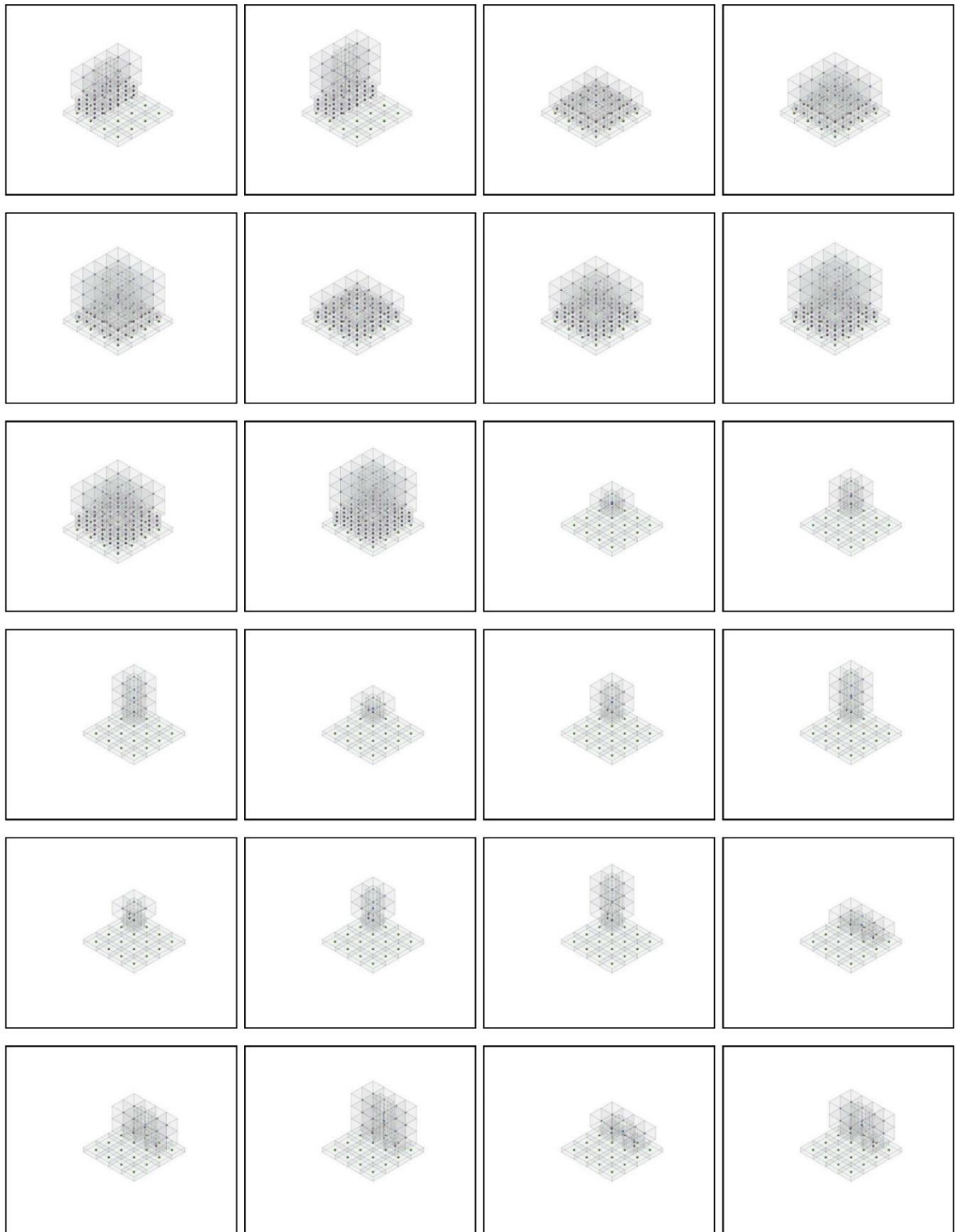

Figure 4.65: Sample of automatically generated (Separation on flat ground)

Chapter 4: Analysis and Synthesis of Building and Ground Relationship

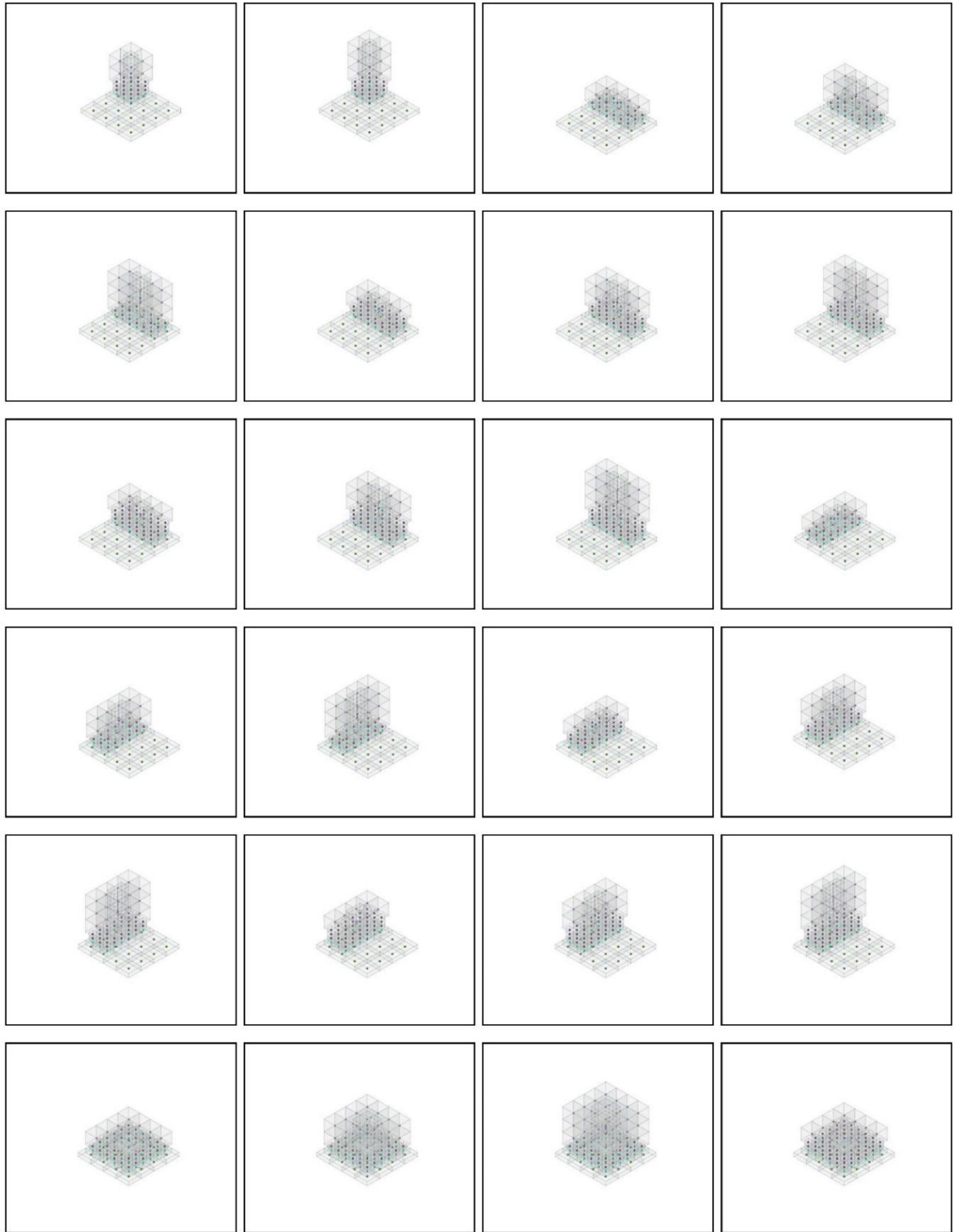

Figure 4.66: Sample of automatically generated (Separation with plinth on flat ground)

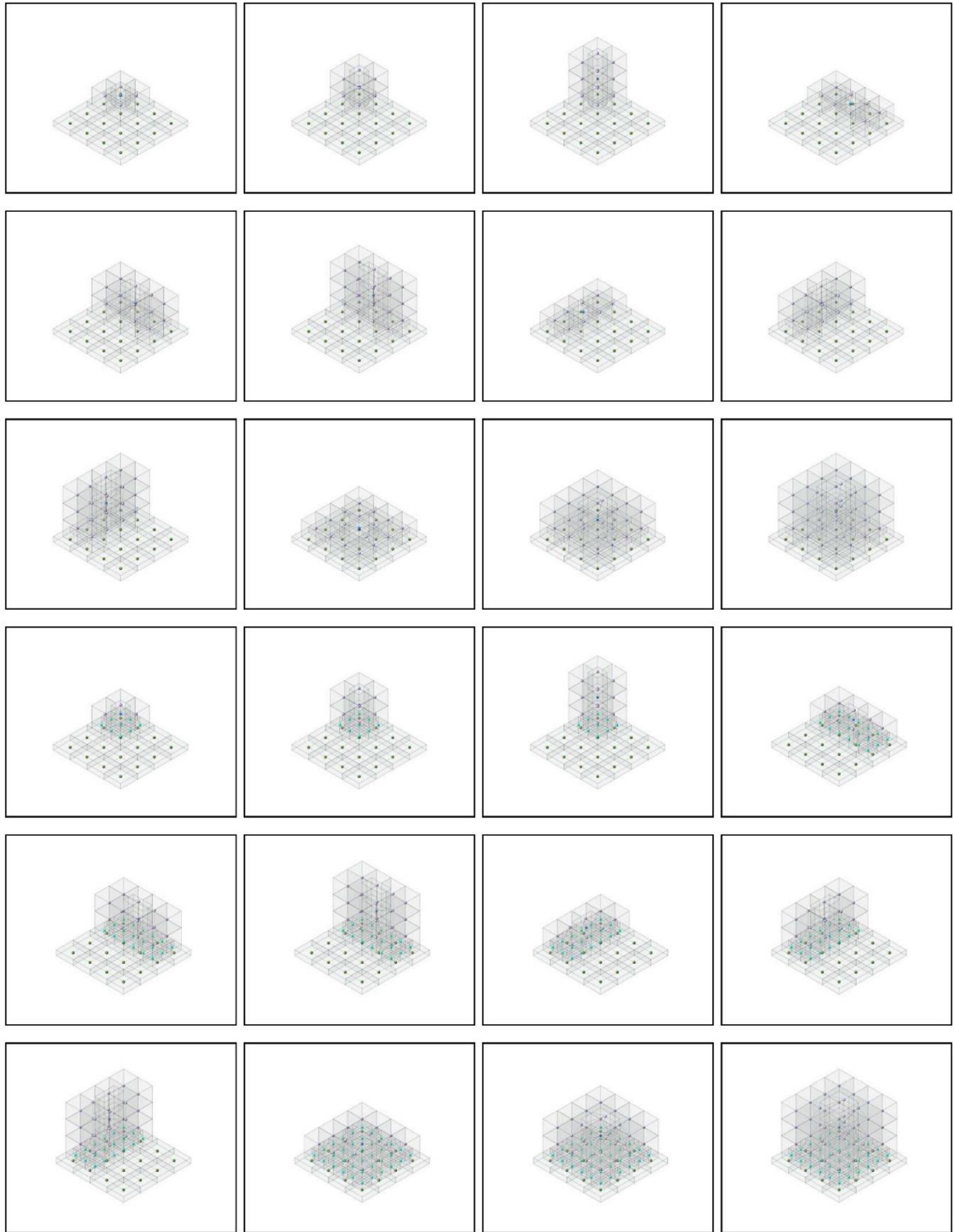

Figure 4.67: Sample of automatically generated (Adherence and Adherence with plinth on flat ground)

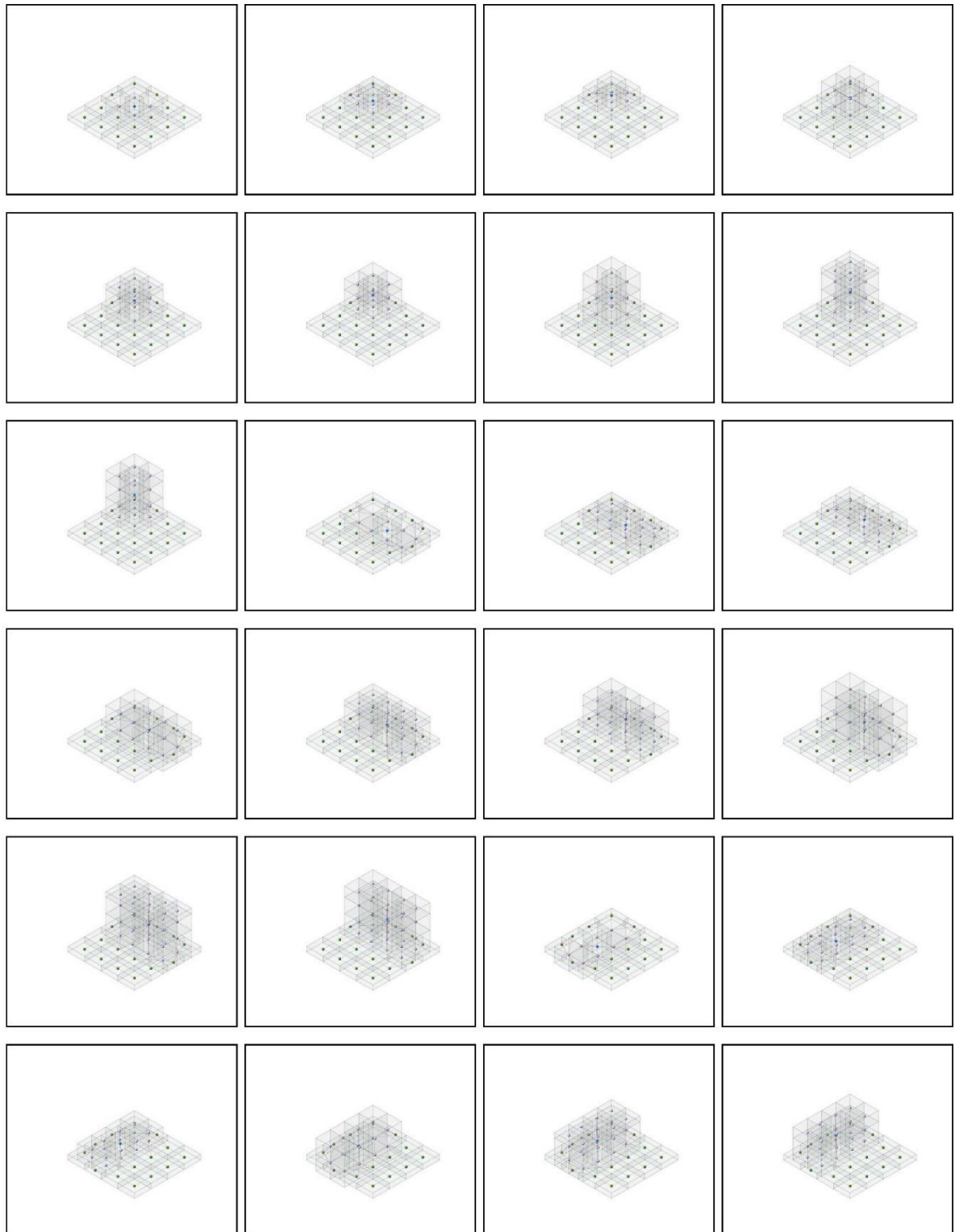

Figure 4.68: Sample of automatically generated (Interlock on flat ground)

**4.6.1.7. Examples of the Generated 3D Topological Building and Ground Relationship
(Sloped Ground) (Figure 4.69 to Figure 4.72).**

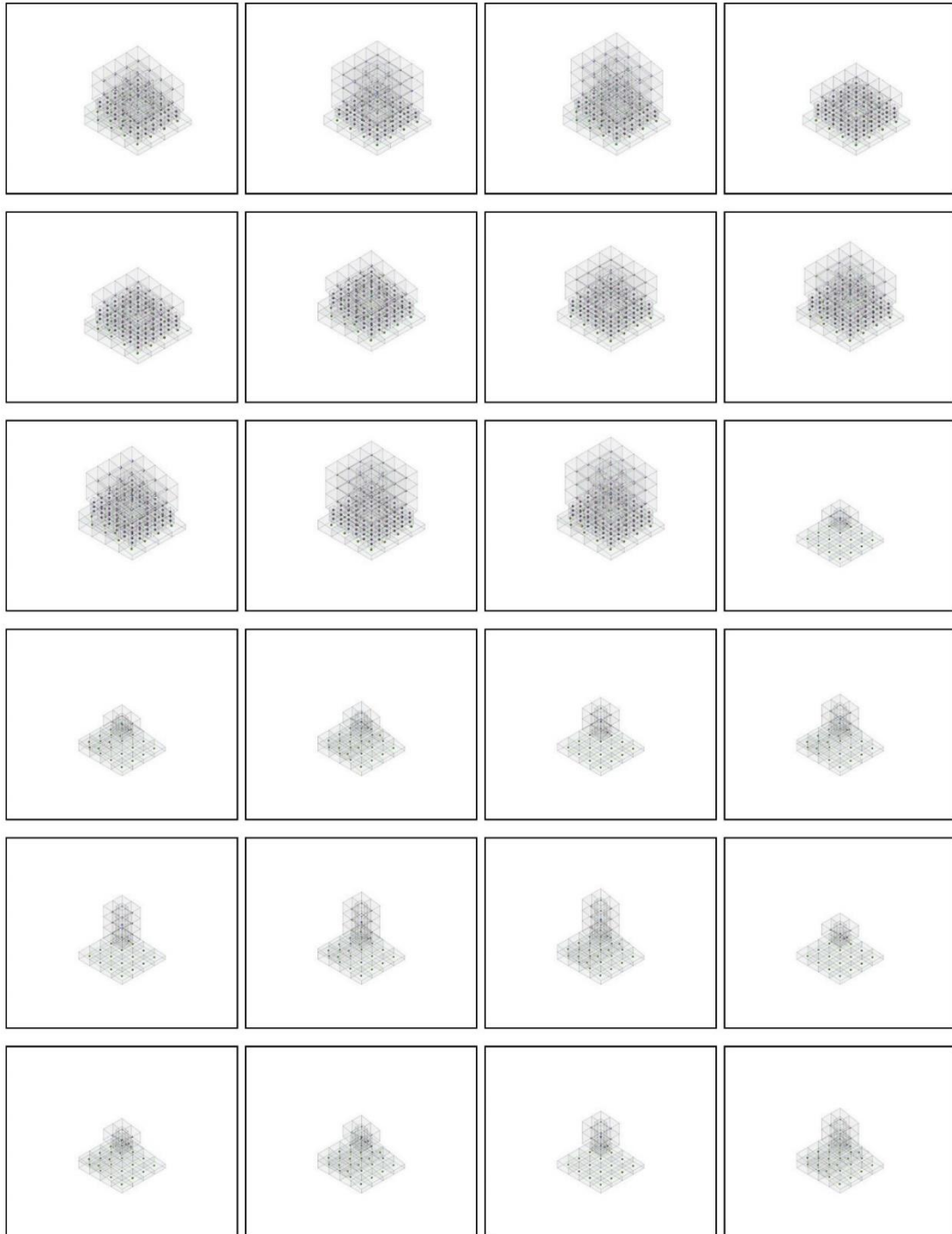

Figure 4.69: Sample of automatically generated (Separation with plinth on sloped ground)

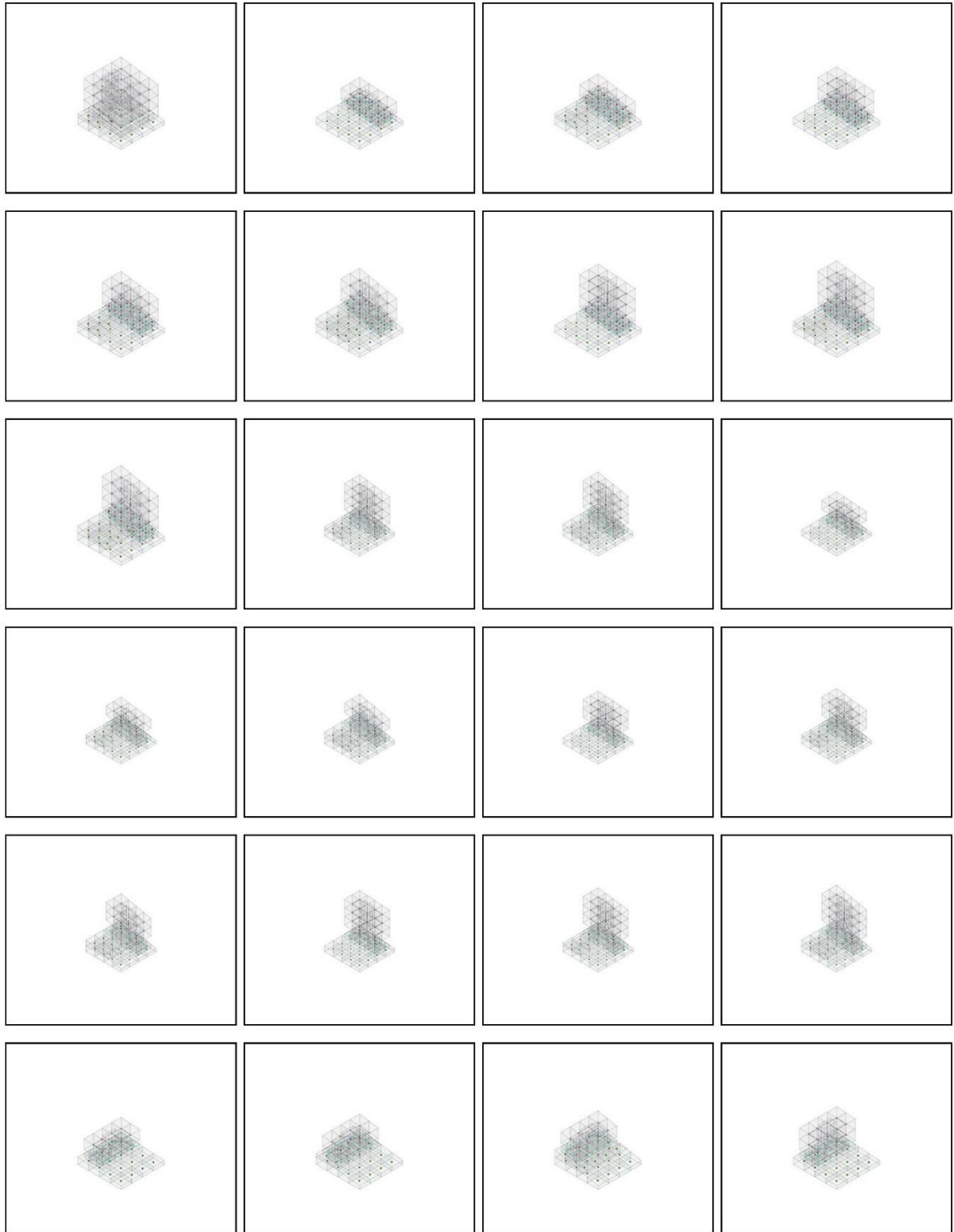

Figure 4.70: Sample of automatically generated (Separation on sloped ground)

Chapter 4: Analysis and Synthesis of Building and Ground Relationship

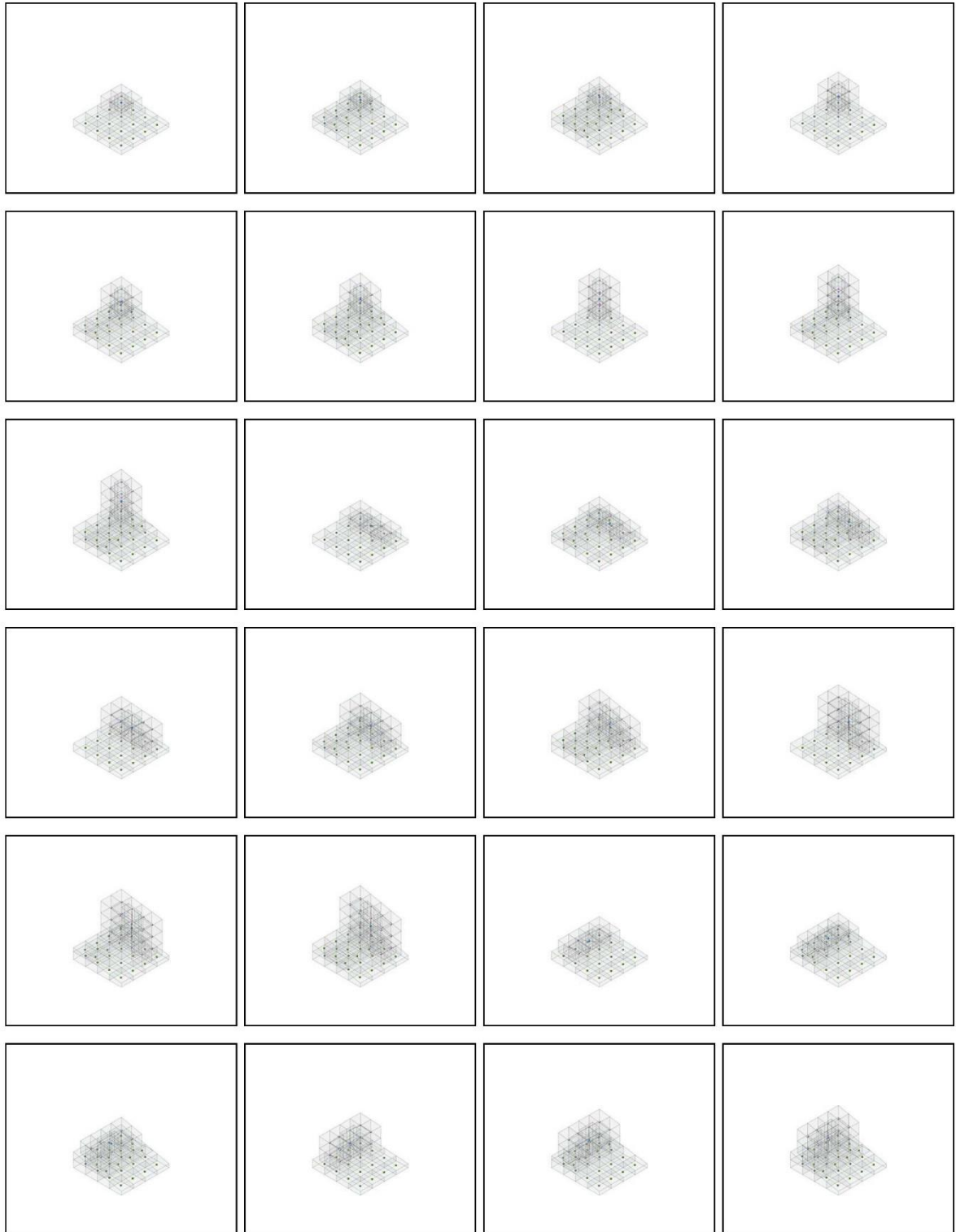

Figure 4.71: Sample of automatically generated (Adherence on sloped ground)



Figure 4.72: Sample of automatically generated (Adherence with plinth on sloped ground)

4.6.1.8. Examples of the Generated 3D Topological Building and Ground relationship (Level Ground) (Figure 4.73 to Figure 4.77)

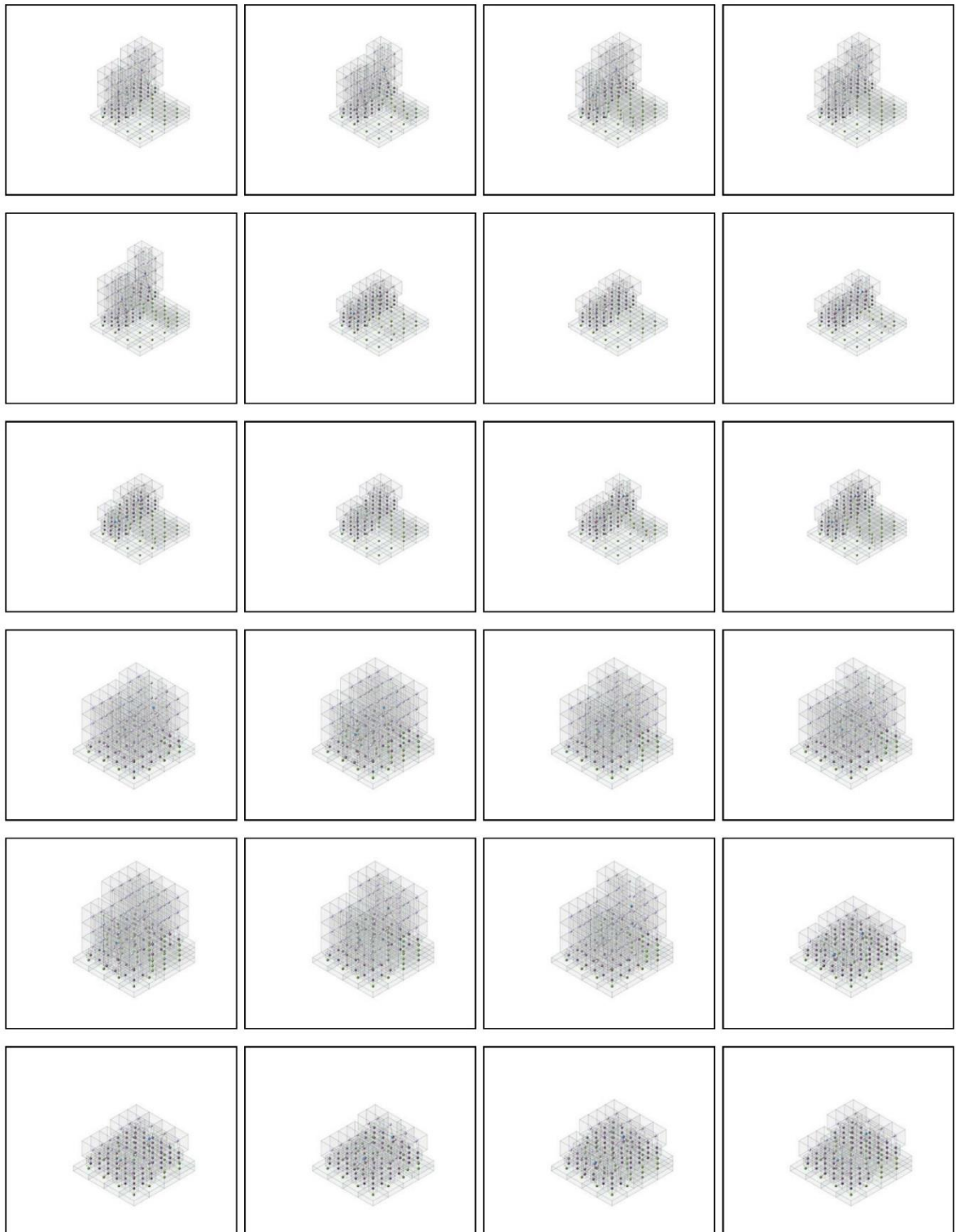

Figure 4.73: Sample of automatically generated (Separation on Level ground)



Figure 4.74: Sample of automatically generated (Separation with plinth on Level ground)



Figure 4.75: Sample of automatically generated (Adherence on Level ground)



Figure 4.76: Sample of automatically generated (Adherence with plinth on Level ground)

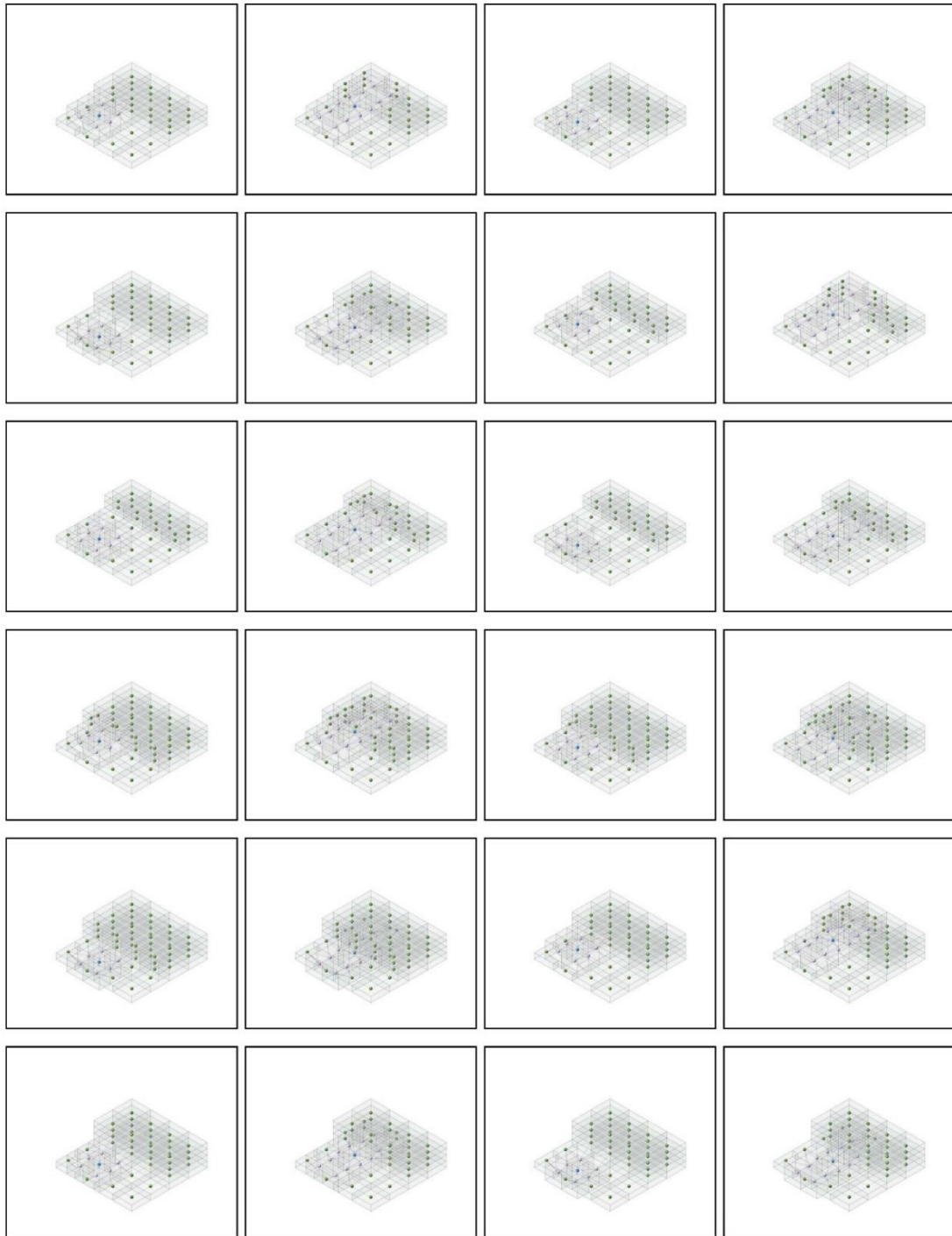

Figure 4.77: Sample of automatically generated (Interlock on Level ground)

4.7. Chapter Summary

Developing a computational model for designing the building by considering the ground in the early design stages requires a holistic approach to clarify the architectural elements that affect the relationship. Based on the information obtained from the interview with architects, it became evident that the architecture profession faces challenges associated with the relationship between the building and the ground during the early stages of design. Additionally, the interview provided an evaluation of the collected building and ground taxonomy and indicated that architects would benefit from classifying and clustering the building and ground relationships using computational design, which would reduce the amount of time and effort spent searching for similar precedents.

Collecting building and ground relationship precedents provides architectural practices with unique datasets that specify this issue. The developed system with 500 different architectural precedents will retrieve a similar case study in a short time and with less effort. Moreover, these precedents extract the rules used in the generated 3D topological building and ground relationship dataset.

Analysing “the main building and ground relationship image sorting survey” revealed that respondents have difficulties sorting the interlock and adherence images. Furthermore, there are difficulties sorting the images of the plinth and foundation in “the building meets the ground image sorting survey”. Thus, these two classes should merge into a single “interlock” category. Most participants misidentified the plinth class as part of the artificial ground. Consequently, merging these two classes into a “plinth” is recommended. Based on these two-image sorting survey results, five classes will be used: separation, adherence, interlock, plinth with separation and plinth with adherence.

Using the predefined five classes, the parametric rules were extracted. These rules were divided into five sets. The sets were as follows: rules for configuring the ground (G), rules for configuring the building (B), rules for configuring the columns (CL), rules for configuring the core (CO) and rules for configuring the plinth (P). These rules generated the 3D topological building and ground relationship dataset.

To perform machine learning, especially deep neural networks, requires a large amount of data. Researchers used Grasshopper and Topologic to generate a synthetic dataset of 3D Topological buildings and ground relationships, employable for machine learning training purposes. This approach saw the researcher produce more than 2,136 graphs.

CHAPTER FIVE

MACHINE LEARNING MODELS TO CLUSTER AND CLASSIFY BUILDING AND GROUND RELATIONSHIP

**Part (A): Unsupervised Machine Learning Model to Clustering Architectural
Precedents**

**Part (B): Graph Machine learning 3D Model to Classifying Building and Ground
Relationship**

Chapter 5: Machine Learning Models to Cluster and Classify Building and Ground Relationship

5.1. Chapter Overview

This chapter aims to implement ML models to cluster and classify building and ground relationships utilising graph theory. This chapter includes two parts. The first part, (Part A: Unsupervised Machine Learning Model to Clustering Architectural Precedents), performs a sensitivity analysis on several clustering algorithms to determine which algorithm proves most suitable to deal with this type of problem. Clustering an architect's style through their approach to the relationship between buildings and the ground allows the categorisation of an extensive database into semantic groups belonging to specific historical periods, building types and regions. These database groups can quickly and effectively retrieve data.

The second part, (Part B: Graph Machine Learning 3D Model to Classifying Building and Ground Relationship), implements a Deep Graph Convolutional Neural Network (DGCNN) to classify 3D building and ground relationship datasets according to their topology. The study employed a morphology based on the shared connection between buildings and the ground to aid the research. This section used the BGR dataset generated in Chapter 4.6 as input to train the DGCNN for graph classification. The Deep Graph Library (DGL) machine learning algorithm verified the results in this section. Moreover, this part examines unsupervised ML approaches. Unsupervised learning focuses on unlabelled data and generates a representation, which can aid future downstream tasks, such as classification. Therefore, the use of Unsupervised Graph-Level Representation Learning (UGLRL) classified the building-ground relationship.

Part (A): Unsupervised Machine Learning to Cluster Architectural Precedents

The primary purpose of this section is to establish an architectural description framework of the building-ground relationship within various architectural styles. The primary concern involves clarifying the different architects' building styles and their relationship with the ground. A cluster machine learning technique will form part of this study to create a taxonomy based on discovered similarities in the relationships between buildings and the ground.

5.2. Clustering the Relationship Between Buildings and the Ground Using Unsupervised Machine Learning Algorithms

Clustering and analysing several case studies will enable the reader to understand the architect's approach to the building-ground relationship. An innovative proof-of-concept workflow was developed to show how a machine learning computer system can learn how to cluster aspects of an architect's style when designing a building and determine how such buildings relate to the ground. Various clustering algorithms have undergone evaluation to determine which algorithm proves most suitable for this type of problem. The Jupyter notebook ran all models using Scikit-learn, a free Python machine learning library. For three reasons, the K-modes and K-means models were selected: (1) the problem must be general-purpose; (2) cluster sizes should be similar; and (3) a moderate number of clusters must be present. The Scikit-learn library implemented the clustering algorithm because it provides an easy way to use the Python language interface (Pedregosa Fabian et al., 2011). Additionally, GMM determined any uncertainties associated with clustering methods. K-means can provide information about which data points belong to which cluster, whereas GMM can provide details about the possible subgroups.

Chapter 4 collected 500 case studies, including residential and public case studies. The study included 304 residential case studies and 196 public case studies. It remains possible that the final cluster result visualisation will differ due to the different scales of the building. Therefore, the unsupervised clustering algorithm was run three times with different datasets. The residential cases were run first, followed by the public cases for all 500 cases.

5.2.1. Performance Evaluation

Two types of performance evaluation can evaluate the algorithm model. The first, external evaluation, utilises information about the datasets, such as normalised mutual information,

the Rand index, and the F-measure. Meanwhile, the second, internal evaluation, assesses the dataset using the silhouette score, Davies-Bouldin index, Partition coefficient and others. The silhouette index score measured the separation distance between the resulting clusters. The silhouette is a method of performance and validation of consistency within clusters of data. The silhouette score displays the closeness of each data point in one group to the neighbouring groups. It has a range of [-1, 0, 1], which means the +1 rating indicates this data is far from the adjacent clusters, while the score closest to - 1 implies that the data might belong to the wrong group. Furthermore, the squared Euclidean distance measured the dissimilarity between objects for K-means and K-modes clustering and computing the silhouette score.

The formula for this distance between a point X (X1, X2, etc.) and a point Y (Y1, Y2, etc.) is:

$$d = \sqrt{\sum_{i=1}^n (x_i - y_i)^2}$$

5.2.2. Data Pre-Processing

A total of 500 architectural precedents were collected for this study. The architectural examples were collected during the data collection step (Chapter 4). The first step after reading the excel data file involves translating the non-numerical data to numerical data to enable the machine to read it (Figure 5.1). Machine learning algorithms cannot work on label data directly. They require all input and output variables to be numerical data. This development means that categorical data requires conversion to a numerical data form. There are two steps for converting categorical data to numerical data: integer encoding and one-hot encoding. In this experiment, a one-hot encoding array acted as a way of changing the input data. One-hot encoding involves converting a categorical variable into a form that enables the ML algorithm to learn more clearly. In a one-hot encoding form, a 0 indicates a non-existing category, while 1 means an existing category (Figure 5.1). The purpose of using one-hot encoding is that it will allow the model to assume a natural ordering between categories (Brownlee 2017).

Architect	Touces Ground	Main Relationship	Metaphors Relationship	Relation with Terrain
50	2	1	1	2
50	1	2	1	0
50	0	0	1	0
50	2	5	1	2
46	2	5	1	2
46	2	5	1	2
50	2	1	1	2

Touces Ground					Main Relationship			Metaphors Relationship					Relation with Terrain				
0	4	5	3	2	1	0	1	2	0	1	2	3	4	0	1	2	3
1	0	0	0	0	0	1	0	0	0	1	0	0	0	1	0	0	0
0	1	0	0	0	0	0	0	1	0	0	0	0	1	1	0	0	0
0	0	0	0	1	0	0	1	0	0	0	0	0	1	1	0	0	0
0	0	0	1	0	0	1	0	0	0	0	1	0	0	1	0	0	0
0	0	0	1	0	0	1	0	0	0	0	1	0	0	1	0	0	0
0	0	0	1	0	0	1	0	0	0	0	1	0	0	1	0	0	0

Figure 5.1: Transferring normal numerical data to one-hot encoding

5.2.3. Experimental Results

Three different unsupervised algorithms were adapted: K-means, K-modes and GMM. An attempt was made to cluster the architectural precedent into different groups called “Architect’s styles”. All experiments set the training and testing ratio to 70 % training data and 30 % testing data. The only changed hyperparameters involved the k number and fitting time. In the experiments, researcher used t-SNE methods to demonstrate the clustering results. T-Distributed Stochastic Neighbour Embedding (t-SNE) visualises unsupervised high-dimensional data by projecting each datapoint to a spot in a 2D or 3D dimensional map (van der Maaten and Hinton 2008). The t-SNE algorithm measures the similarity between pairs of states in high-dimensional and low-dimensional spaces. It then tries to improve these two similarities using the cost function. Moreover, we used Elbow methods to determine the optimal number of clusters. Elbow methods consider the contrast ratio shown as a function of the number of clusters (Bholowalia and Kumar 2014). We identified the “elbow criterion” by following the line chart that resembles an arm. The point of inflection on the curve then acts as an indication of the best model provided at that point (Yellowbrick 2016).

5.2.3.1. All dataset Experimental Results

This experiment used all the data collected in chapter 4. The purpose of this experiment is to see how the machine can cluster different types of architectural precedents, which are residential and public.

5.2.3.1.1. K-Means and K-Mode’s Experiment Results

The K-means algorithm was run with different numbers of clusters (Table 5.1). The best silhouette score related to the appropriate time was found in Cluster 4, with a 0.64 silhouette score (82%). In K-means, the model did not affect the time like the other algorithms; therefore, the best result appeared at k=11, which reached a 0.88 silhouette score (94%). However, the purpose of using clustering algorithms is to find a small clustering number. Therefore, the acceptable number of clusters compared with this piratical kind of problem appeared in the fourth cluster (Figure 5.2, left).

In parallel, the K-modes algorithm was run using the same number of clusters (Figure 5.2, right). The best silhouette score appeared with five clusters with a silhouette score of 0.64 (82 %). This development proved similar to the K-means algorithm. Furthermore, the Elbow methods suggested that the best cluster number is K=3, which is the silhouette score of less than 0.58 (79 %). This result proved worse than K-means. Moreover, the K-modes model showed no improvement of the score after the 5 k; an increase only appeared in Cluster 10, with a 0.66 silhouette score (83 %). While both clustering algorithms revealed strong accuracy, the K-means method yielded a better silhouette score with less fit time.

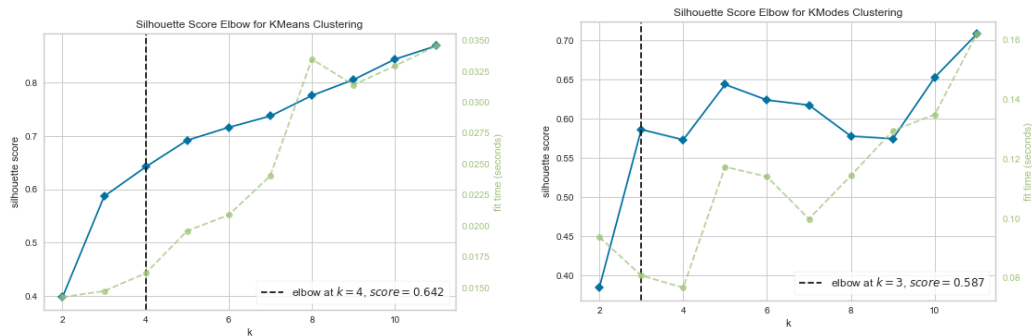

Figure 5.2: Silhouette score Elbow for K-means clustering (left) and K-modes clustering (right)

To validate the results obtained from K-means, the study used a plot t-SNE to show the clustering distribution. In the t-SNE graph, all four clusters show a clear group separation. Therefore, the algorithm worked well in terms of the partitioning concept (Figure 5.3, left). Equally, in the K-modes algorithms, the four-cluster plot demonstrates clear separation (Figure 5.3, right). A comparison between K-means and K-modes shows both models have a clear plot t-SNE, which means both succeed in describing the partitioning idea.

Chapter 5: Machine Learning Models to Cluster and Classify Building and Ground Relationship

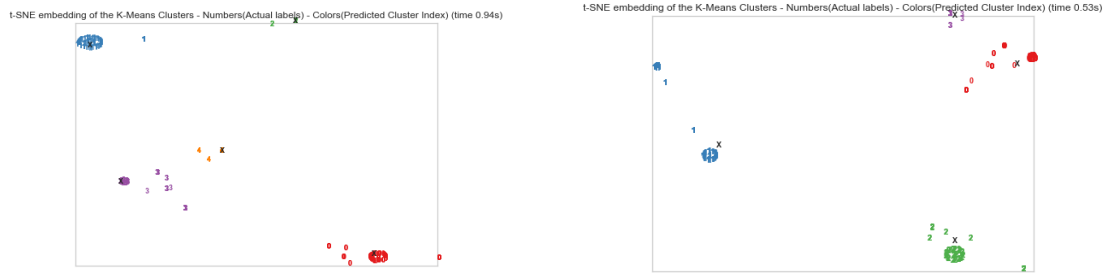

Figure 5.3: t-SNE embedding of the K-means clusters (left) and K-modes clusters (right)

To visualise the results, the testing result was split into groups of images. The figure below shows the architectural precedents and their designers. To present all clusters, only 20% of testing data were presented (Figure 5.4).



Figure 5.4: Examples of clusters of architects' styles in four groups of building and ground relationships

Cluster 0 presented similar architectural styles, which involved interlock approaches to the ground. The case studies grouped in Cluster 0 were: (1) Villa Tugendhat by Ludwing Mies Van der Rohe, (2) First Unitarian Society of Madison by Frank Lloyd Wright, (3) Lovell House by

Chapter 5: Machine Learning Models to Cluster and Classify Building and Ground Relationship

Richard Neutra, (4) Scarborough Home by Borrmeister Architects, (5) House on The Rocks by Fran Silvestre Architects, (6) C-Glass House, by Deegan Day Design LLC, (7) Camillo Alps Villa by Botticini Architetto, (8) Harris house by Rudolph schindle and (9) Vega Cottage by Kolman Boye Architects.

On other hand, **Cluster 1** presented similar architectural styles, which involved adherence approaches to the ground. The case studies grouped in Cluster 1 were: (1) Johnson House by Frank Lloyd Wright, (2) Singleton House by Richard Neutra, (3) Casa Bucerius House by Richard Neutra, (4) Summer Seaside House by Joakim Hoen, (5) Serpentine Gallery Pavilion by Toyo Ito, (6) Endesa Pavilion by Institute for Advanced Architecture of Catalonia, (7) National Taichung Opera House by Toyo Ito, (8) Plaza Biblioteca by Gonzalez Moix Architects Sur, (9) Venturi House by Robert Venturi, (10) Mountain Cabin by Marte Architects,(11) The Riverside Museum by Zaha Hadid, (12) Wuxi TAIHU Show Theatre By Steven Chilton Architects, (13) Sculpture Studio by Modus Studio and (14) Jetwan House by Design Work Group.

Cluster 2 presented similar architectural styles, which involved separation approaches to the ground. The case studies grouped in Cluster 2 were: (1) Villa Savoye by Le Corbusier, (2) Pavillon Suisse by Le Corbusier, (3) David and Gladys Wright House by Frank Lloyd Wright, (4) Colección Jumex by David Chippereld Architects, (5) Villa Vpro by MVRDV, (6) Blur Building by Diller Scodio and Renfro, (7) Centro Sports by Thom Mayne, (8) Learning Hub by Heatherwick Studio, (9) Media Perra House by Santos Bolívar, (10) Simgok by SsD and (11) Zeidler Residence by Bernard Zimmerman.

Finally, **Cluster 3** presented similar architectural styles, which involved Interlock approaches to the ground while this time is more merging in the ground. The case studies grouped in Cluster 3 were: (1) George Sturges House by Frank Lloyd Wright, (2) SØF Maritime Museum by Bjarke Ingels Group, (3) Meydan - Umraniyet by Foreign Office, (4) Leca Swimming Pool by Alvaro Siza and (5) Olympic Archery Rang by Enric Miralles and Carme Pinos.

5.2.3.1.2. GMM Experiment Results

The GMM algorithm ran in a different number of clusters (Figure 5.5, left). The purpose of using GMM involved locating uncertainty in the groups. The t-SNE of the GMM experiment shows no overlap between the clusters, which means that all the groups were partitioning (Figure 5.5, right). Moreover, GMM obtained a good accuracy result, such as a 0.69 silhouette score (84.5 %) at Cluster 5. Comparing the GMM rustles with K-Means and K-Modes at similar K number K=4, we found that GMM performs similarly to K-Means and K-Modes with a silhouette score of 0.64 (82 %).

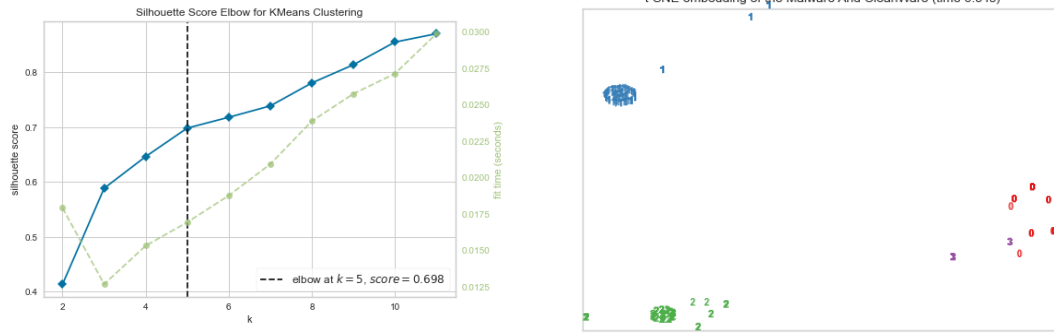

Figure 5.5: Silhouette Score Elbow for GMM clustering (Left), t-SNE embedding of GMM clusters (Right)

Table 5.1: Results of different machine learning algorithms (K-Means, K-Modes and GMM) with different K numbers

Clustering Methods	K-Means		K-Modes		GMM	
	Silhouette score	% Accuracy	Silhouette score	% Accuracy	Silhouette score	% Accuracy
3	0.59	79.5%	0.58	79%	0.59	79.5%
4	0.64	82%	0.56	78%	0.64	82%
5	0.69	84.5%	0.66	83%	0.69	84.5%

5.2.3.2. Residential Dataset Experimental Results

5.2.3.2.1. K-Means and K-Mode’s Experiment Results

The K-means algorithm was run with different numbers of clusters (Table 5.2). The best silhouette score related to the appropriate time was found in Cluster 5, with a silhouette score of 0.69 (84.5%). In parallel, the K-modes algorithm was run using the same number of clusters (Figure 5.6). The best silhouette score was found in Cluster 4, with a silhouette score of 0.64 (82%). Moreover, in the K-modes model, no improvement of the score appeared after the 4 K; an increase only appeared in Cluster 11, with a silhouette score of 0.68 (84%). While both clustering algorithms revealed strong accuracy, the K-means method yielded a better overall silhouette score with less fit time.

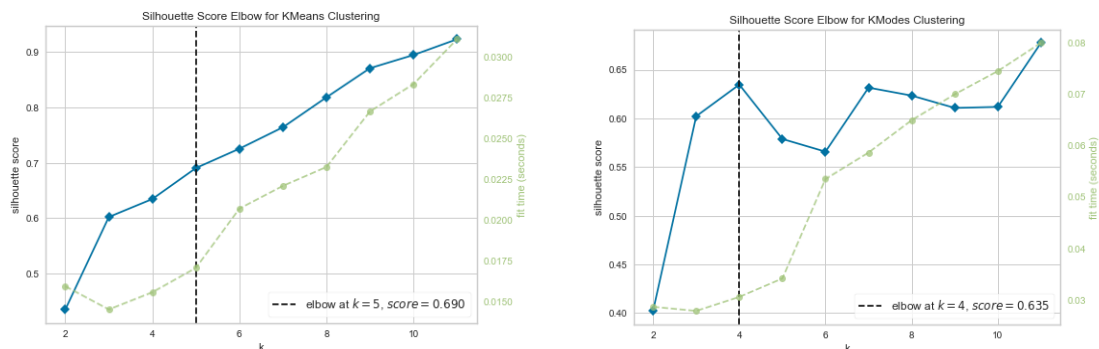

Chapter 5: Machine Learning Models to Cluster and Classify Building and Ground Relationship

Figure 5.6: Silhouette Score Elbow for K-Means clustering (Left) and K-Mode's clustering (Right)

To validate the results obtained from K-means, a plot t-SNE showed the clustering distribution. In the t-SNE graph, all four clusters show a clear group separation. Therefore, the algorithm worked well in terms of the partitioning concept (Figure 5.7, left). Equally, in the K-modes algorithms, the four-cluster plot demonstrates clear separation (Figure 5.7 right). A comparison between K-means and K-modes shows both models have a clear plot t-SNE, which means both succeed in describing the partitioning idea.

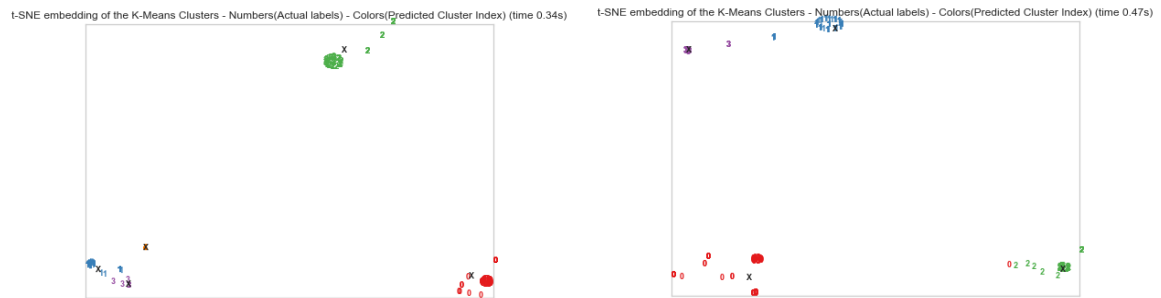

Figure 5.7: t-SNE embedding of the K-means clusters (left) and K-modes clusters (right)

To visualise the results, the testing result was split into groups of images. The figure below shows the architectural precedents and their designers. To present all clusters, only 20% of testing data were presented (Figure 5.8).

Chapter 5: Machine Learning Models to Cluster and Classify Building and Ground Relationship

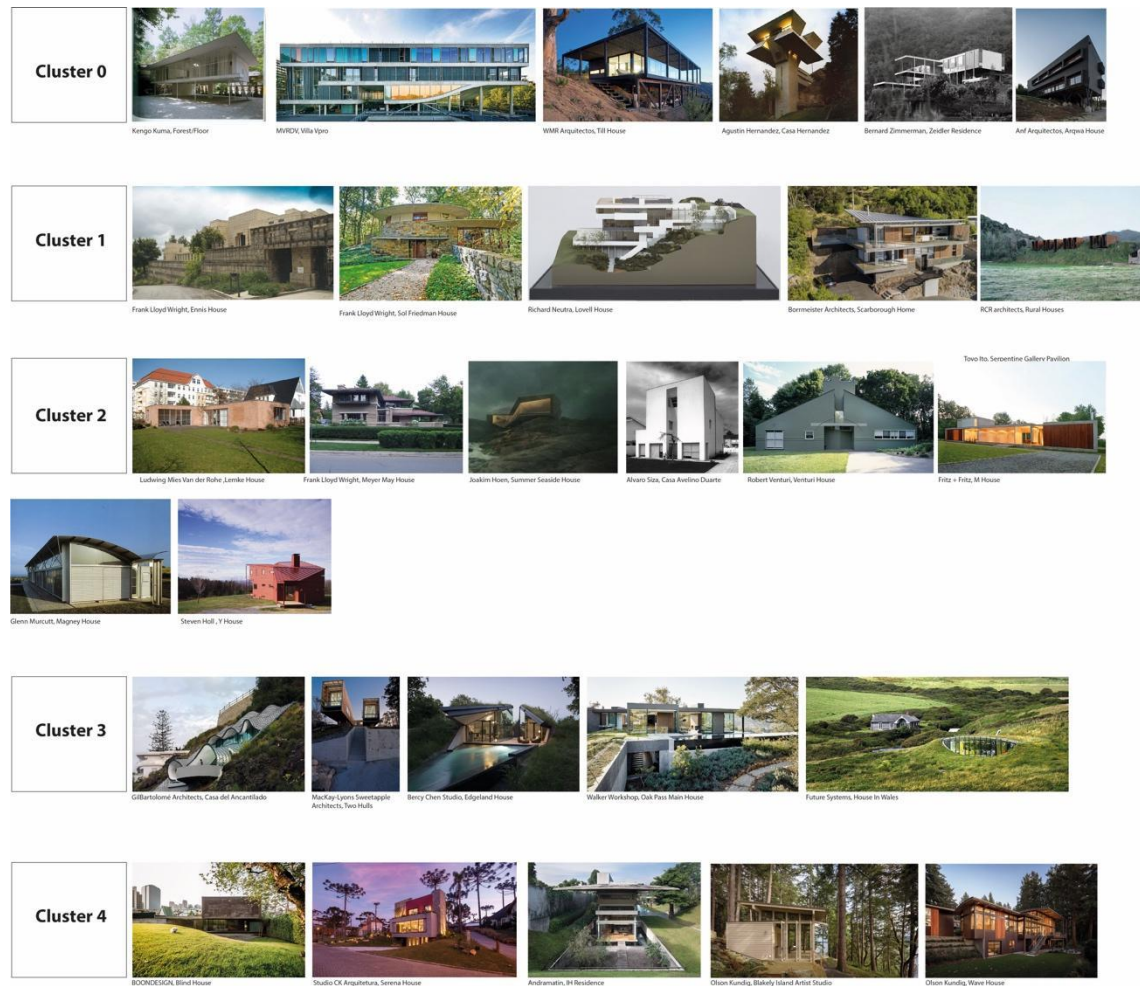

Figure 5.8: Examples of clusters architects' styles in different five groups of building and ground relationship for residential houses

Similar architectural styles were present in **Cluster 0**, including Separation approaches to the ground. The case studies grouped in Cluster 0 were: (1) Forest/Floor by Kengo Kuma, (2) Villa Vpro by MVRDV, (3) Till House by WMR Arquitectos, (4) Casa Hernandez by Agustin Hernandez, (5) Zeidler Residence by Bernard Zimmerman and (6) Arqwa House by Anf Arquitectos.

In **Cluster 1**, similar architectural styles involved interlocking ground approaches. The case studies grouped in Cluster 1 were: (1) Ennis House by Frank Lloyd Wright, (2) Sol Friedman House by Frank Lloyd Wright, (3) Lovell House by Richard Neutra, (4) Scarborough Home by Borrmester Architects and (5) Rural Houses by RCR architects.

In contrast, **Cluster 2** showcased similar architectural styles using Adherence approaches. The case studies grouped in Cluster 2 were: (1) Lemke House by Ludwig Mies Van der Rohe, (2) Meyer May House by Frank Lloyd Wright, (3) Summer Seaside House by Joakim Hoen, (4) Casa

Chapter 5: Machine Learning Models to Cluster and Classify Building and Ground Relationship

AveliNo.Duarte by Alvaro Siza, (5) Magney by Glenn Murcutt, (6) Y House by House Steven Holl, (7) Venturi House by Robert Venturi and (8) M House by Fritz + Fritz.

Furthermore, **Cluster 3** featured similar architectural styles, which also involved Interlock. Compared to cluster 1, this cluster has a "grounded" approach to the ground. The case studies grouped in Cluster 3 were: (1) Casa del Ancantilado by Gil Bartolomé Architects, (2) Two Hulls by MacKay-Lyons Sweetapple Architects, (3) Edgeland House by Bercy Chen Studio, (4) Oak Pass Main House by Walker Workshop and (5) House in Wales by Future Systems.

Finally, **Cluster 4** presented the similar architectural styles, which involved Interlock as well. However, the difference between this cluster and Clusters 1 and 3 is that the building touches the ground with foundation support. The case studies grouped in Cluster 4 were: (1) Blind House by BOONDESIGN, (2) Serena House by Studio CK Arquitetura, (3) IH Residence by Andramatin, (4) Blakely Island Artist Studio by Olson Kundig and (5) Wave House by Olson Kundig.

5.2.3.2.2. GMM Experiment Results

The GMM algorithm was run with a different number of clusters (Table 5.2) to locate uncertainty in the groups. The t-SNE of the GMM experiment shows no overlap between the clusters, which means that all the groups were separated from each other (Figure 5.9). Moreover, it obtained a good accuracy result, a silhouette score of 0.68 (84%) at Cluster 5. Comparing the GMM rustles with K-Means and K-Modes at similar K number K=5, we found that GMM performs similarly to K-Means with a silhouette score of 0.68 (84%).

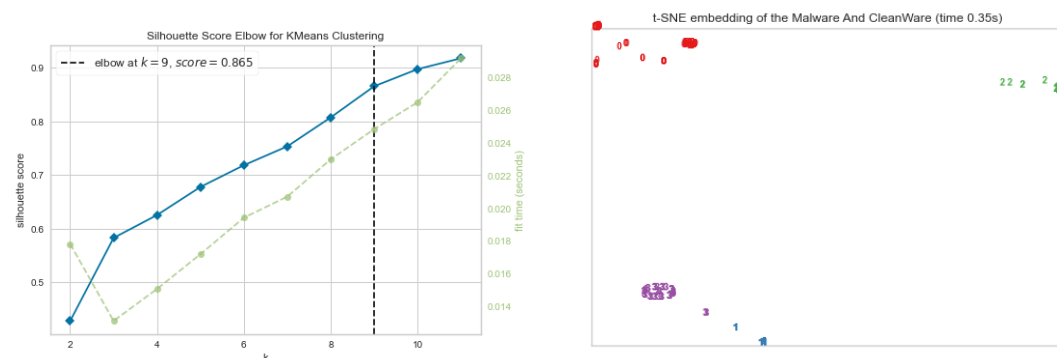

Figure 5.9: Silhouette Score Elbow for GMM clustering (Left), t-SNE embedding of GMM clusters (Right)

Table 5.2: Residential dataset experimental results of different machine learning algorithms (K-Means, K-Modes and GMM) with different numbers of K

Clustering Methods	K-Means		K-Modes		GMM	
	Silhouette score	% Accuracy	Silhouette score	% Accuracy	silhouette score	% Accuracy
3	0.61	80.5%	0.61	80.5%	0.59	79.5%
4	0.64	82%	0.69	84.5%	0.63	81.5%
5	0.69	84.5%	0.57	78.5%	0.68	84%

5.2.3.3. Public Dataset Experimental Results

5.2.3.3.1. K-Means and K-Mode’s Experiment Results

The K-means algorithm was run with different numbers of clusters (Table 5.3). The best silhouette score related to the appropriate time was found in Cluster 4, with a silhouette score of 0.67 (83.5%). In K-means, the time was not affected by the model like the other algorithms; therefore, the best result was found at K=10, which reached a 0.88 silhouette score (94 %). However, the purpose of using clustering algorithms is to find a small number of clustering. Therefore, the acceptable number of clusters compared with this piratical kind of problem appeared in Cluster 5, which featured a silhouette score of 0.70 (85%),(Figure 5.10, left).

In parallel, the K-modes algorithm was run using the same number of clusters (Figure 5.10, right). The best silhouette score was found with five clusters with a silhouette score of 0.70 (85%). This finding proved similar to the K-means algorithm. Furthermore, the elbow method suggested that the best cluster number is K=4, which has a silhouette score of 0.67 (83.5%). This result proved similar to the K-means algorithm. While both clustering algorithms revealed strong accuracy, the K-means method yielded a better overall silhouette score with less fit time.

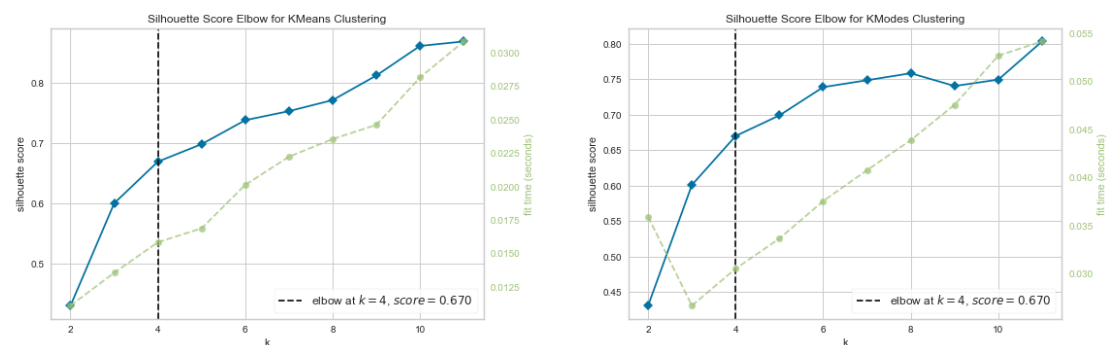

Figure 5.10: Silhouette score Elbow for K-Means Clustering (Left) and K-Modes Clustering (Right)

To validate the results obtained from K-means, a plot t-SNE showed the clustering distribution. In the t-SNE graph, all five clusters show a clear group separation. Therefore, the algorithm

Chapter 5: Machine Learning Models to Cluster and Classify Building and Ground Relationship

worked well in terms of the partitioning concept (Figure 5.11, left). Equally, in the K-modes algorithms, the five-cluster plot demonstrates clear separation (Figure 5.11, right). A comparison between K-means and K-modes shows both models have a clear plot t-SNE, which means both succeed in describing the partitioning idea.

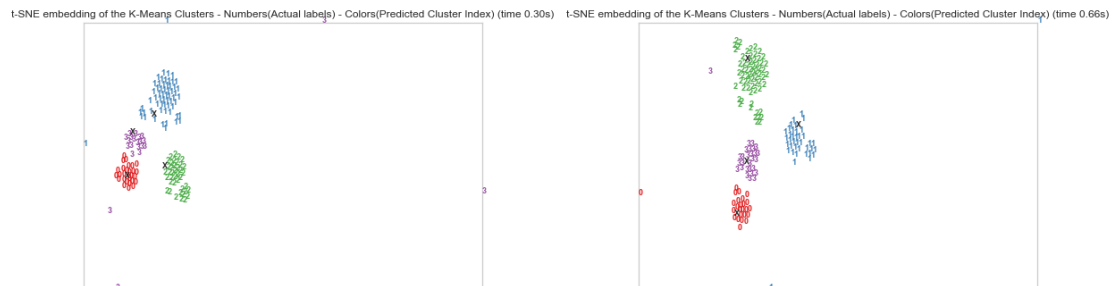

Figure 5.11: t-SNE embedding of the K-Means clusters (Left) and K-Modes clusters (Right)

To visualise the results, the testing result was split into groups of images. Architectural precedents and their designers are shown in the (Figure 5.12). To present all clusters, only 20% of testing data were presented.

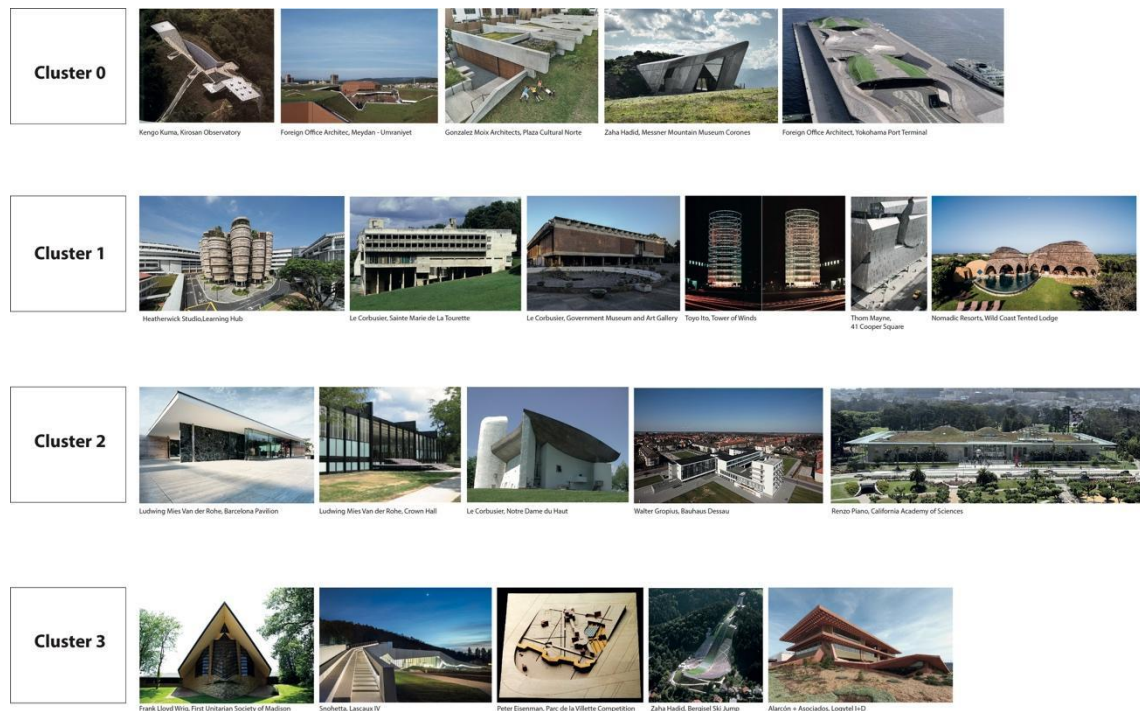

Figure 5.12: Examples of clusters architects' styles in different four groups of building and ground relationship for public dataset

Cluster 0 presented similar architectural styles, which involved Interlock approaches to the ground. Examples of the case studies grouped in Cluster 0 were: (1) Kiroan Observatory by Kengo Kuma, (2) Meydan - Umrianiyet by Foreign Office Architect, (3) Plaza Cultural Norte by Gonzalez Moix Architects, (4) Messner Mountain Museum Coronas by Zaha Hadid, (5)

Chapter 5: Machine Learning Models to Cluster and Classify Building and Ground Relationship

Yokohama Port Terminal by Foreign Office Architect and (6) Logytel I+D by Alarcón + Asociados.

Cluster 1 presented similar architectural styles, which involved Separation approaches to the ground. Examples of the case studies grouped in Cluster 0 were: (1) Learning Hub by Heatherwick Studio, (2) Sainte Marie de La Tourette by Le Corbusier, (3) Government Museum and Art Gallery by Le Corbusier, (4) Tower of Winds by Toyo Ito, (5) 41 Cooper Square by Thom Mayne and (6) Wild Coast Tented Lodge by Nomadic Resorts.

On other hand, **Cluster 2** presented similar architectural styles, which involved Adherence approaches to the ground. Examples of the case studies grouped in Cluster 2 were: (1) Notre Dame du Haut by Le Corbusier, (2) Bauhaus Dessau by Walter Gropius, (3) California Academy of Sciences by Renzo Piano, (4) Barcelona Pavilion by Ludwig Mies Van der Rohe and (5) Crown Hall by Ludwig Mies Van der Rohe.

Finally, **Cluster 3** presented similar architectural styles, which involved Interlock, although the difference between this cluster and Clusters 1 and 3 is the building touches the ground with foundation support. Examples of the case studies grouped in Cluster 4 were: (1) First Unitarian Society of Madison by Frank Lloyd Wright, (2) Lascaux IV by Snohetta, (3) Parc de la Villette Competition by Peter Eisenman, (4) Bergisel Ski Jump by Zaha Hadid and (5) Logytel I+D by Alarcón + Asociados.

5.2.3.3.2. GMM Experiment Results

The GMM algorithm was run in a different number of clusters (Table 5.3) to locate uncertainty in the groups. The t-SNE of the GMM experiment shows no overlap between the clusters, which means all the groups were partitioning (Figure 5.13). Moreover, GMM obtained a good accuracy result, such as a 0.68 silhouette score (84%) at Cluster 5. Comparing the GMM rustles with K-Means and K-Modes at similar K number K=4, we found that GMM performs similarly to K-Means, with a 0.68 silhouette score (84%).

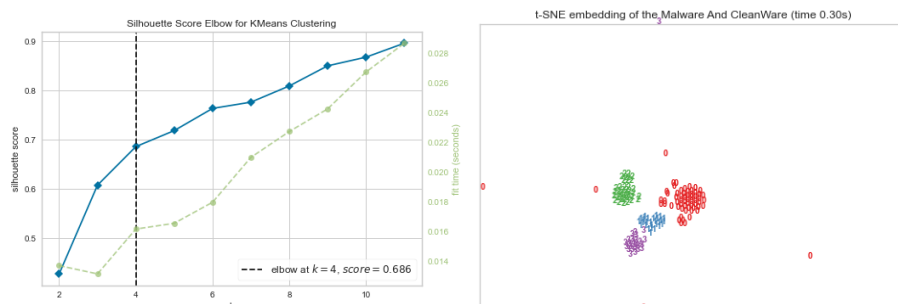

Figure 5.13: Silhouette Score Elbow for GMM clustering (Left), t-SNE embedding of GMM clusters (Right)

Chapter 5: Machine Learning Models to Cluster and Classify Building and Ground Relationship

Table 5.3: Residential dataset experimental results of different machine learning algorithms (K-Means, K-Modes and GMM) with different numbers of K

Clustering Methods	K-Means		K-Modes		GMM	
	Silhouette score	% Accuracy	Silhouette score	% Accuracy	Silhouette score	% Accuracy
3	0.61	80.5%	0.61	80.5%	0.61	80.5%
4	0.67	83.5%	0.67	83.5%	0.68	84%
5	0.70	85%	0.70	85%	0.68	84%

According to the results shown in Table 5.1, Table 5.2 and, Table 5.3, all the models reach a high level of accuracy. High model performance requires selecting the optimum number of clusters. In this case, the ideal k number was five clusters. The K-means model offers the most consistent accuracy. The purpose of using GMM was to locate uncertainty in the groups. However, in this model, GMM does not provide this probability because of the data points' separation into groups. Although the GMM model does not cluster soft assignments, it clusters hard assignments with similarly high accuracy to K-means. The results seem to demonstrate that K-Means, K-Modes and GMM achieved high accuracy in clustering architects' styles. Therefore, this approach would lend itself well for use by researchers to create taxonomy based on a similarity between architectural precedents.

Part (B): Graph Machine Learning 3D Model to Classifying the Building and Ground Relationship

In this section, a Deep Graph Convolutional Neural Network (DGCNN) is utilized to classify 3D topological building and ground relationships (BGRs). Experiments were conducted to tune the hyperparameters to optimize DGCNN. The best-optimised model was saved to test the model with unseen data. Then, to generalise the model, DGCNN predicted new scenarios never previously trained. In this part, the same dataset was tested with a different machine learning algorithm (DGL). Furthermore, the researcher tests the use of Unsupervised Graph Level Representation Learning (UGLRL) to classifying the task and then representing the whole graph in embedded space.

5.3. Deep Graph Convolutional Neural Network

Presented here is a summary of the DGCNN's structure: Firstly, the input graph passes through several layers of graph convolution in which the node information is propagated between neighbours. Following this, a SortPooling layer sorts and pools the vertex features before passing those features to a conventional CNN structure for learning a prediction model.

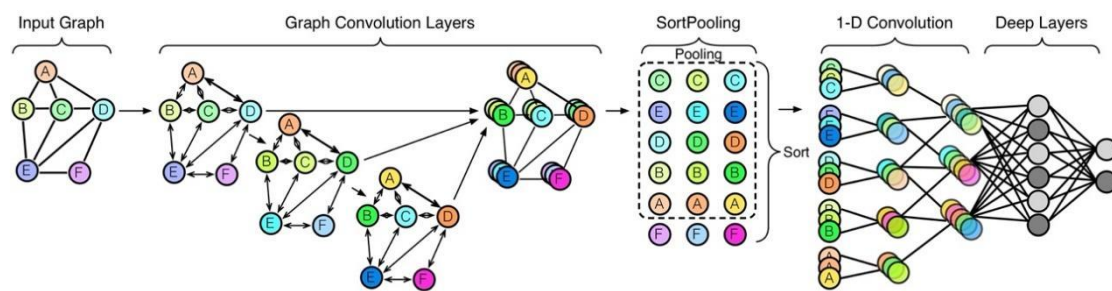

Figure 5.14: The general structure of DGCNN (re-presented after : Zhang et al. 2018)

The figure above shows the DGCNN structure. The DGCNN structure consists of three stages: 1) graph convolution layers determine the local substructure features of vertices and determine a vertex ordering; 2) a SortPooling layer arranges the vertices in the previously defined order; and 3) traditional convolutional and dense layers perform predictions using the sorted graph representations.

5.3.1. The Dataset Detail

This experiment used the BGR dataset. The total number of graphs amounts to 2,136. The nodes total 171,232. The average vertices per graph are 80. The minimum number of vertices is 20. The maximum number of vertices is 258.

5.3.2. Splitting the Dataset

Initially, the dataset is split into training, validation, and testing sets. The 2,136 graphs were divided into 70% training, and testing and 30% validation. Per the experimental results below, we varied the following hyperparameters: the number of convolutional layers, the number of neurons in the convolutional layer, the number of hidden layers for the final dense layer, the number of epochs, the learning rate and the batch size. 70% of the total dataset (1,496 graphs) was used as training and testing to optimize the hyperparameters (Figure 5.15).

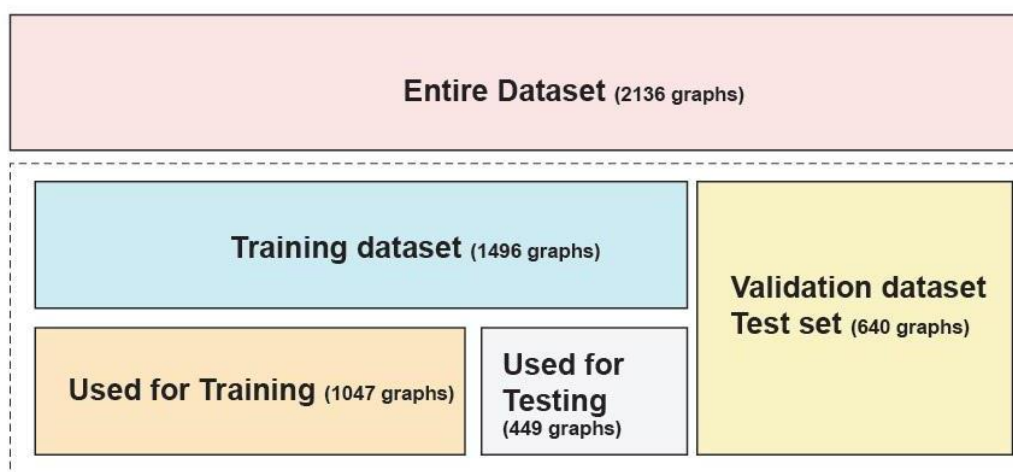

Figure 5.15: The dataset split into training, validation, and testing sets

5.3.3. Optimisation of Deep Graph Convolutional Neural Network (DGCNN)

Hyperparameter tuning helps to optimise the performance of machine learning models. Tuning hyperparameters involves selecting the best hyperparameters for a learning algorithm. This experiment used a random search method to create a grid of possible values for each parameter. This grid is iterated over successively, recording the performance for each combination of parameters, and returning the best combination. To optimise the DGCNN architecture, the flowing hyperparameter was modified. The modified hyperparameter was, the number of convolutional layers, number of neurons in the convolutional layer, number of hidden layers for the final dense layer, number of epochs, learning rate and batch size (Table 5.4).

Chapter 5: Machine Learning Models to Cluster and Classify Building and Ground Relationship

Table 5.4: The hyperparameters used to tune the best model

Number of convolutional layers	Number of neural in the convolutional layer	Number of hidden layers for final dense layers	Number of epochs	Learning rate	Batch size
1	32	64	500	1e-5	1
2	64	128	300	1e-4	2
3	128	256	200	1e-3	5
			100	1e-2	10
					20

The experiment starts with a varying number of neurons in the convolutional layer. The test involved 32, 64 and 128 layers, and the best two results were used in the subsequent experiments. Various convolutional layers were then examined: one, two and three convolutional layers. The two best numbers of convolutional layers results were reported and used in the subsequent experiments. The experiments then varied the number of hidden layers for the final de40

se layers. The study tested and reported 64, 128 and 256 hidden layers for final dense layers. The best experiment result was used in the subsequent experiments. The investigation then carried on with a varying number of epochs. Various epochs were tested, such as 500, 300, 200 and 100. The best experiment result was used in the subsequent experiments. Then, the investigation carried on tuning the learning rate. The final set of experiments varied the batch size. Different batch sizes, such as 1, 2, 5, 10 and 20, were reported in this last set of experiments.

5.3.3.1. Number of Neurons in the Convolutional Layer

Before training the network, one of the hyperparameters requiring specification is the filter size. The neurons that make up convolutional neural networks have learnable weights and biases. The neurons receive inputs, perform a dot product, and optionally follow it up with a nonlinear effect. In the following experiments, the number of neural in the convolutional layer was tested with 32, 64 and 128 neurals (Table 5.5). All three experiments reported a high result. However, the best accuracy results were reported in Experiment 1 (32 neural) and Experiment 2 (64 neural) with 98.2% and 98.7% accuracy, respectively (Table 5.5). Therefore, the subsequent experiments used this neural in the convolutional layer to continue tuning and improving the accuracy of the results.

Table 5.5: Tuning number of neural in the convolutional layer

Serial experiment No.	Number of neural in the convolutional layer	Loss	Accuracy
Experiment 1	32	0.053	98.2 %

Chapter 5: Machine Learning Models to Cluster and Classify Building and Ground Relationship

Experiment 2	64	0.041	98.7 %
Experiment 3	128	0.049	97.8 %

5.3.3.1.1. Experiment 1

The experiment's model demonstrates a high level of accuracy (98.2%), with three layers of 32 neurons. (Figure 5.16, right), illustrates the average loss in every number of epochs. The loss metric is calculated based on training and validation and interpreted as the model's performance on these two sets. The experiment started with a 1.322 loss, and then the model sharply decreased in the first 25 epochs to approximately 0.3. Following 25 epochs, the loss gradually decreased to reach 0.053. On the other hand, the average accuracy (Figure 5.16, left) shows a sharp increase in the accuracy in the first 25 epochs to reach more than 90%. After 25 epochs, the accuracy gradually increased to 98.2%.

Code 1: Experiment 1 model structure

1. Namespace(batch_size=1, conv1d_activation='ReLU', data='DIT', dropout=True, edge_feat_dim=0, extract_features=False, feat_dim=0, fold=1, gm='DGCNN', hidden=128, latent_dim=[32, 32, 32, 1], learning_rate=1e-05, max_lv=4, mode='cpu', num_class=0, num_epochs=200, out_dim=0, predict=False, printAUC=False, seed=1, sortpooling_k=0.6, test_number=449)
2. loading data
3. # classes: 5
4. # maximum node tag: 5
5. {4: 0, 0: 1, 1: 2, 3: 3, 2: 4}
6. # train: 1047, # test: 449
7. k used in SortPooling is: 81

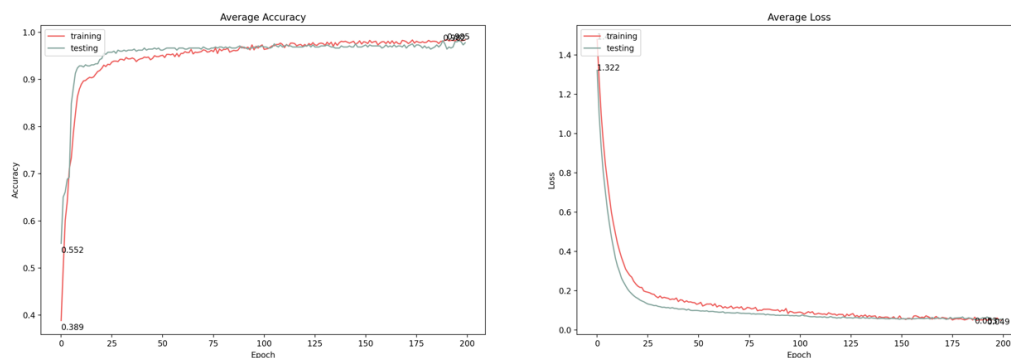

Figure 5.16: Experiment 1 average accuracy (left), average loss (right)

5.3.3.1.2. Experiment 2

The experiment's model demonstrates a high level of accuracy (98.7%), with three layers of 64 neurons, which exceeds the first experiment (0.5%). (Figure 5.17, right) illustrates the average loss in every number of epochs. The investigation started with a 1.322 loss on the training set, and then the model sharply decreased in the first 25 epochs to approximately 0.3. Regarding the later 25 epochs, the loss gradually decreased to reach 0.044, better than the first experiment by 0.012. On the other hand, the average accuracy (Figure 5.17, left) shows a

sharp accuracy increase in the first 25 epochs to reach more than 90%. After 25 epochs, the accuracy gradually increased to 98.7%.

Code 2: Experiment 2 model structure

1. Namespace(batch_size=1, conv1d_activation='ReLU', data='DIT', dropout=True, edge_feat_dim=0, extract_features=False, feat_dim=0, fold=1, gm='DGCNN', hidden=128, latent_dim=[64, 64, 64, 1], learning_rate=1e-05, max_lv=4, mode='cpu', num_class=0, num_epochs=200, out_dim=0, predict=False, printAUC=False, seed=1, sortpooling_k=0.6, test_number=449)
2. loading data
3. # classes: 5
4. # maximum node tag: 5
5. {4: 0, 0: 1, 1: 2, 3: 3, 2: 4}
6. # train: 1047, # test: 449
7. k used in SortPooling is: 81

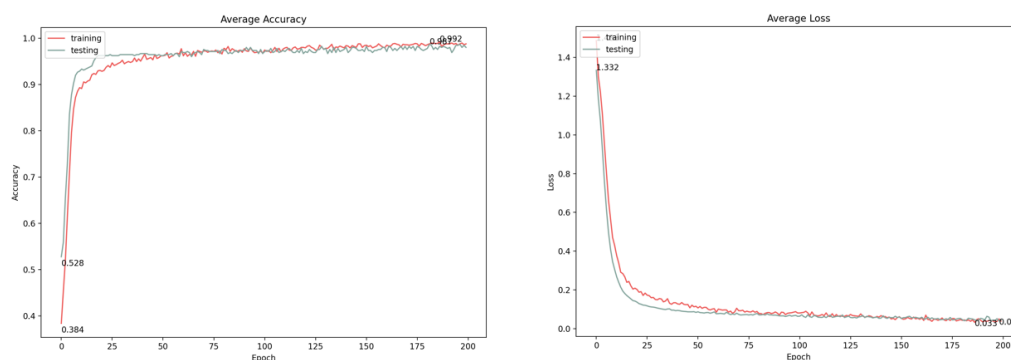

Figure 5.17: Experiment 2 average accuracy (left), average loss (right)

5.3.3.1.3. Experiment 3

This experiment is the final test that varies the number of neural in the convolutional layer. The experiment's model demonstrates a high accuracy (97.8%) (Figure 5.18, left), although it proves lower than the first two experiments (0.4 and 0.9). Moreover, the loss function proves higher than in the first experiment by approximately (0.04) (Figure 5.18, right). Due to the recommendation in ML, using the least number of hidden neurons is necessary to accomplish the task since adding each hidden neuron will increase the number of weights and complexity. Therefore, the best two models with higher accuracy (32 and 64 neurons) were selected for the subsequent experiments (Table 5.5).

Code 3: Experiment 3 model structure

1. Namespace(batch_size=1, conv1d_activation='ReLU', data='DIT', dropout=True, edge_feat_dim=0, extract_features=False, feat_dim=0, fold=1, gm='DGCNN', hidden=128, latent_dim=[128, 128, 128, 1], learning_rate=1e-05, max_lv=4, mode='cpu', num_class=0, num_epochs=200, out_dim=0, predict=False, printAUC=False, seed=1, sortpooling_k=0.6, test_number=449)
2. loading data
3. # classes: 5
4. # maximum node tag: 5
5. {4: 0, 0: 1, 1: 2, 3: 3, 2: 4}
6. # train: 1047, # test: 449

7. k used in SortPooling is: 81

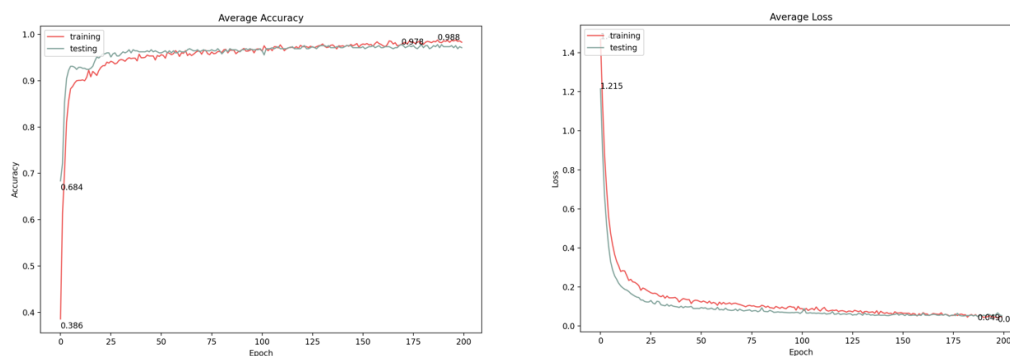

Figure 5.18: Experiment 3 average accuracy (left), average loss (right)

5.3.3.2. Number of Convolutional Layers

Since the layers of convolution are stacked, we can decompose the input in a hierarchical way. Convolutional layers comprise the prime components of convolutional neural networks. A convolutional neural network works by multiplying a set of weights with the input. Since the technique was designed for two-dimensional data input, each input is multiplied by an array of weights called a filter or kernel. Varying the layers and neural numbers can affect the results' accuracy. However, all the results exceed 97.8% accuracy. In the following six experiments (Experiment 4 to Experiment 9), the number of convolutional layers varied. Moreover, the neural number in the convolutional layer was maintained at 32 and 64 (Table 5.6). The best two experiments were reported on the two layers of "32 -32-1" and three layers of "64-64 -64-1" with 98.8% accuracy and 98.7% accuracy, respectively (Table 5.6). Therefore, subsequent experiments used these two convolutional layers.

Table 5.6: Tuning the number of convolutional layers

Serial Experiment No.	Number of convolutional layers	Loss	Accuracy
Experiment 4	One layer of "32 -1"	0.068	98.0 %
Experiment 5	Two layers of "32 -32-1"	0.045	98.9 %
Experiment 6	Three layers of "32-32 -32-1"	0.053	98.2 %
Experiment 7	One layer of "64 -1"	0.078	97.8 %
Experiment 8	Two layers of "64 -64-1"	0.044	98.7 %
Experiment 9	Three layers of "64-64 -64-1"	0.041	98.7 %

5.3.3.2.1. Experiment 4

With one layer of 32 neurons, the experiment's model shows high accuracy (98.0%). (Figure 5.19, right), is the average loss per epoch. The experiment started with a loss of 1.39 on the training set, and then in the first 50 epochs, the loss sharply decreased to approximately 0.2. Thereafter, the loss gradually decreased to 0.068. In contrast, the average accuracy (Figure 5.19, left) shows a sharp increase in accuracy over the first 25 epochs to exceed 90%. Over time, the accuracy increased to 98% after 25 epochs.

Code 4: Experiment 4 model structure

```

1. Namespace(batch_size=1,conv1d_activation='ReLU', data='DIT', dropout=True, edge_feat_dim=0,
extract_features=False, feat_dim=0, fold=1, gm='DGCNN', hidden=128, latent_dim=[32, 1],
learning_rate=1e-05, max_lv=4, mode='cpu', num_class=0, num_epochs=200, out_dim=0, predict=Fals2e,
printAUC=False, seed=1, sortpooling_k=0.6, test_number=449)
2. loading data
3. # classes: 5
4. # maximum node tag: 5
5. {4: 0, 0: 1, 1: 2, 3: 3, 2: 4}
6. # train: 1047, # test: 449
7. k used in SortPooling is: 81
    
```

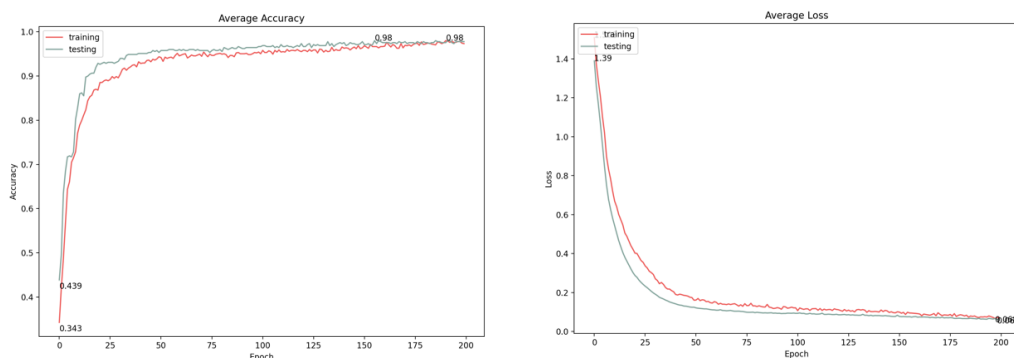

Figure 5.19: Experiment 4 average accuracy (left), average loss (right)

5.3.3.2.2. Experiment 5

With two layers of 32 neurons, the experiment model shows a high level of accuracy (98.8%). The following figure shows the average loss for every epoch (Figure 5.20, right). With a 1.32 loss on the training set, the model quickly decreased in the first 25 epochs to approximately 0.2. After another 25 epochs, the loss gradually decreased to approximately 0.045. A sharp increase in accuracy appears in the first 25 epochs of the average accuracy (Figure 5.20, left) to reach more than 90% on the training set. Over the next 25 epochs, the accuracy gradually increased to 98.9%. This model is one of the best performance models. Therefore, the subsequent experiments used this hyperparameter.

Code 5: Experiment 5 model structure

1. Namespace(batch_size=1, conv1d_activation='ReLU', data='DIT', dropout=True, edge_feat_dim=0, extract_features=False, feat_dim=0, fold=1, gm='DGCNN', hidden=128, latent_dim=[32, 32, 1], learning_rate=1e-05, max_lv=4, mode='cpu', num_class=0, num_epochs=200, out_dim=0, predict=False, printAUC=False, seed=1, sortpooling_k=0.6, test_number=449)
2. loading data
3. # classes: 5
4. # maximum node tag: 5
5. {4: 0, 0: 1, 1: 2, 3: 3, 2: 4}
6. # train: 1047, # test: 449
7. k used in SortPooling is: 81

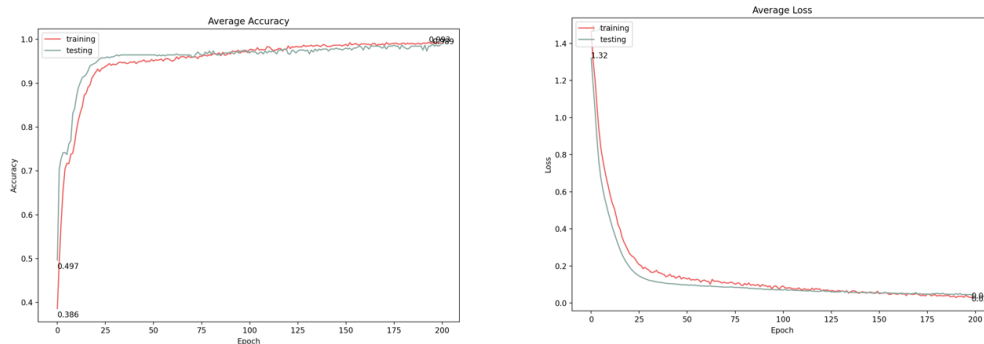

Figure 5.20: Experiment 5 average accuracy (left), average loss (right)

5.3.3.2.3. Experiment 6

With three layers of 32 neurons, the experiment model shows a high level of accuracy (98.2%). (Figure 5.21, right), shows the average loss for every epoch. With a 1.322 loss on the training set, the model quickly decreased in the first 25 epochs to approximately 0.2. After 25 epochs, the loss gradually decreased to approximately 0.053. On the other hand, a sharp increase in accuracy appears in the first 15 epochs of the average accuracy (Figure 5.21, left) to reach more than 95% on the training set. Over the next 185 epochs, the accuracy gradually increased to 98.2%. Despite the model bearing high accuracy, it lacks suitability for use in the following experiments.

Code 6: Experiment 6 model structure

1. Namespace(batch_size=1, conv1d_activation='ReLU', data='DIT', dropout=True, edge_feat_dim=0, extract_features=False, feat_dim=0, fold=1, gm='DGCNN', hidden=128, latent_dim=[32, 32, 32, 1], learning_rate=1e-05, max_lv=4, mode='cpu', num_class=0, num_epochs=200, out_dim=0, predict=False, printAUC=False, seed=1, sortpooling_k=0.6, test_number=449)
2. loading data
3. # classes: 5
4. # maximum node tag: 5
5. {4: 0, 0: 1, 1: 2, 3: 3, 2: 4}
6. # train: 1047, # test: 449
7. k used in SortPooling is: 81

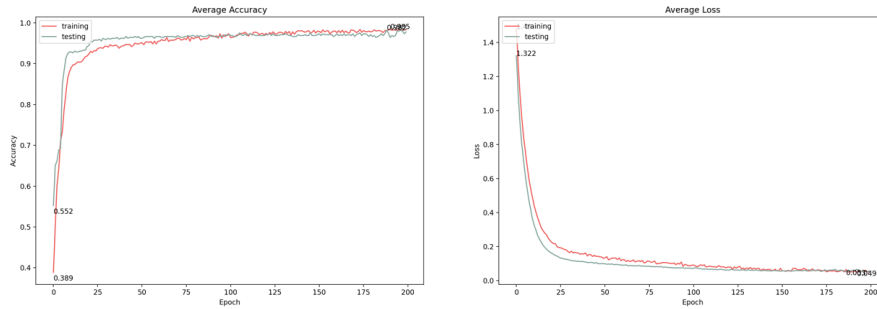

Figure 5.21: Experiment 6 average accuracy (left), average loss (right)

5.3.3.2.4. Experiment 7

With one layer of 64 neurons, the experiment model shows a high accuracy (97.8%). (Figure 5.22, right), shows the average loss for every epoch. With a 1.322 loss on the training set, the model quickly decreased in the first 25 epochs to approximately 0.2. After 25 epochs, the loss gradually decreased to approximately 0.078. On the other hand, a sharp increase in accuracy appears in the first 20 epochs of the average accuracy (Figure 5.22, left) to reach more than 95% on the training and testing set. Over the next 180 epochs, the accuracy gradually increased to 97.8%. Despite the model bearing high accuracy, it lacks suitability for the following experiments.

Code 7: Experiment 7 model structure

1. Namespace(batch_size=1, conv1d_activation='ReLU', data='DIT', dropout=True, edge_feat_dim=0, extract_features=False, feat_dim=0, fold=1, gm='DGCNN', hidden=128, latent_dim=[64, 1], learning_rate=1e-05, max_lv=4, mode='cpu', num_class=0, num_epochs=200, out_dim=0, predict=False, printAUC=False, seed=1, sortpooling_k=0.6, test_number=449)
2. loading data
3. # classes: 5
4. # maximum node tag: 5
5. {4: 0, 0: 1, 1: 2, 3: 3, 2: 4}
6. # train: 1047, # test: 449
7. k used in SortPooling is: 81

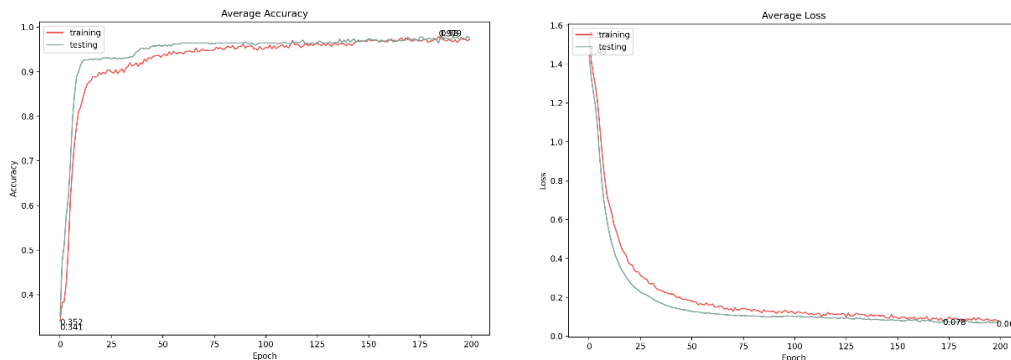

Figure 5.22: Experiment 7 average accuracy (left), average loss (right)

5.3.3.2.5. Experiment 8

With two layers of 64 neurons, the experiment model shows a high accuracy level (98.7%). (Figure 5.23, right), shows the average loss for every epoch. With a 1.377 loss on the training set, the model quickly decreased in the first 25 epochs to approximately 0.2. After 25 epochs, the loss gradually decreased to approximately 0.044. On the other hand, a sharp increase in accuracy appears in the first 20 epochs of the average accuracy (Figure 5.23, left) to reach more than 95% on the training and testing set. Over the next 180 epochs, the accuracy gradually increased to 98.7%.

Code 8: Experiment 8 model structure

```

1. Namespace(batch_size=1, conv1d_activation='ReLU', data='DIT', dropout=True, edge_feat_dim=0,
extract_features=False, feat_dim=0, fold=1, gm='DGCNN', hidden=128, latent_dim=[64, 64, 1],
learning_rate=1e-05, max_lv=4, mode='cpu', num_class=0, num_epochs=200, out_dim=0,
predict=False, printAUC=False, seed=1, sortpooling_k=0.6, test_number=449)
2. loading data
3. # classes: 5
4. # maximum node tag: 5
5. {4: 0, 0: 1, 1: 2, 3: 3, 2: 4}
6. # train: 1047, # test: 449
7. k used in SortPooling is: 81
    
```

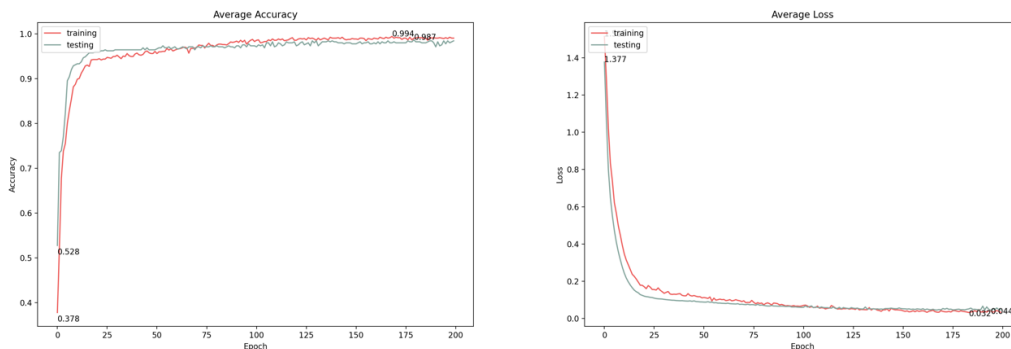

Figure 5.23: Experiment 8 average accuracy (left), average loss (right)

5.3.3.2.6. Experiment 9

Using three layers of 64 neurons, the experiment model achieves 98.7% accuracy. (Figure 5.24, right), testing the average loss for every epoch. After suffering a loss of 1.33 on the training set, the model rapidly decreased to approximately 0.25 after 25 epochs. The loss decreased over 25 epochs and reached approximately 0.041. However, a dramatic increase in accuracy occurs after the first 20 epochs (Figure 5.24, left) that exceeds 95% on the training and testing data. In the subsequent 180 epochs, the accuracy gradually increased to 98.7%. Although the performance of this experiment aligns with that of the last experiment, it has a better loss. Thus, the most suitable two models with higher accuracy and lower loss were Experiments 5

and 9, consisting of two layers of "32-32-1" and three layers of "64-64-64-1", respectively. The hyperparameters for both experiments were selected for further analysis (Table 5.7).

Code 9: Experiment 9 model structure

```

1. Namespace(batch_size=1, conv1d_activation='ReLU', data='DIT', dropout=True, edge_feat_dim=0,
extract_features=False, feat_dim=0, fold=1, gm='DGCNN', hidden=128, latent_dim=[64, 64, 64, 1],
learning_rate=1e-05, max_lv=4, mode='cpu', num_class=0, num_epochs=200, out_dim=0,
predict=False, printAUC=False, seed=1, sortpooling_k=0.6, test_number=449)
2. loading data
3. # classes: 5
4. # maximum node tag: 5
5. {4: 0, 0: 1, 1: 2, 3: 3, 2: 4}
6. # train: 1047, # test: 449
7. k used in SortPooling is: 81
    
```

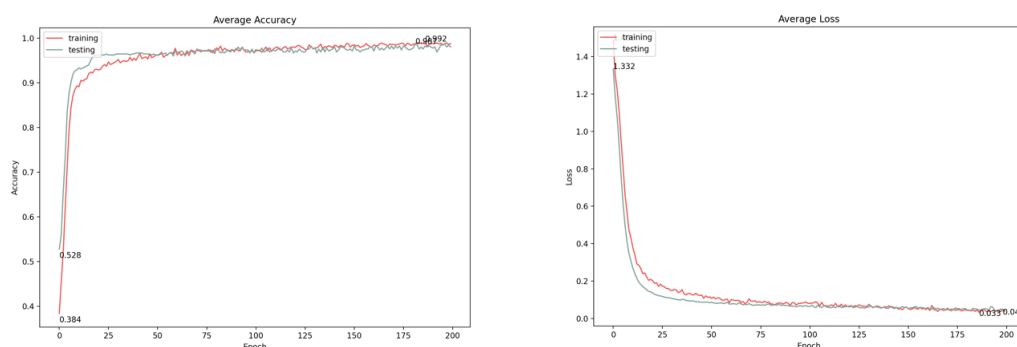

Figure 5.24: Experiment 9 average accuracy (left), average loss (right)

5.3.3.3. Number of Hidden Layers for Final Dense Layers

Several neurons are arranged in the dense layer, in which each neuron receives input from the previous layer’s neurons. Dense layers classify images or graphs based on the output of convolutional layers. In the following five experiments (Experiments 10 to 15), the researcher used the following number of hidden neurons for the final dense layer: 64, 128 and 256.

Table 5.7: Tuning the number of hidden neurons for final dense layers

Serial experiment No.	Number of convolutional layers	Number of hidden neurons for final dense layers	Loss	Accuracy
Experiment 10	Two layers of “32 -32-1”	64	0.057	98.0%
Experiment 11	Three layers of “32 -32-1”	256	0.049	98.7%
Experiment 12	Three layers of “64-64 -64-1”	256	0.051	98.0%

5.3.3.3.1. Experiment 10

A model based on two layers of 32 convolutional neurons and 64 hidden neurons for the dense layer shows high accuracy (98.0%). (Figure 5.25, right), displays the average loss for each epoch. Initially, the model had a 1.39 loss on the training set, which quickly decreased to approximately 0.20 after 25 epochs. Over the course of 25 epochs, the loss decreased

gradually to approximately 0.057. In contrast, a sharp increase in accuracy appears in the first 20 epochs of average accuracy (Figure 5.25, left), reaching over 90% for the training and testing data. The accuracy increased gradually over the following 180 epochs, reaching 98.0%.

Code 10: Experiment 10 model structure

1. Namespace(batch_size=1, conv1d_activation='ReLU', data='DIT', dropout=True, edge_feat_dim=0, extract_features=False, feat_dim=0, fold=1, gm='DGCNN', hidden=64, latent_dim=[32, 32, 1], learning_rate=1e-05, max_lv=4, mode='cpu', num_class=0, num_epochs=200, out_dim=0, predict=False, printAUC=False, seed=1, sortpooling_k=0.6, test_number=449)
2. loading data
3. # classes: 5
4. # maximum node tag: 5
5. {4: 0, 0: 1, 1: 2, 3: 3, 2: 4}
6. # train: 1047, # test: 449
7. k used in SortPooling is: 81

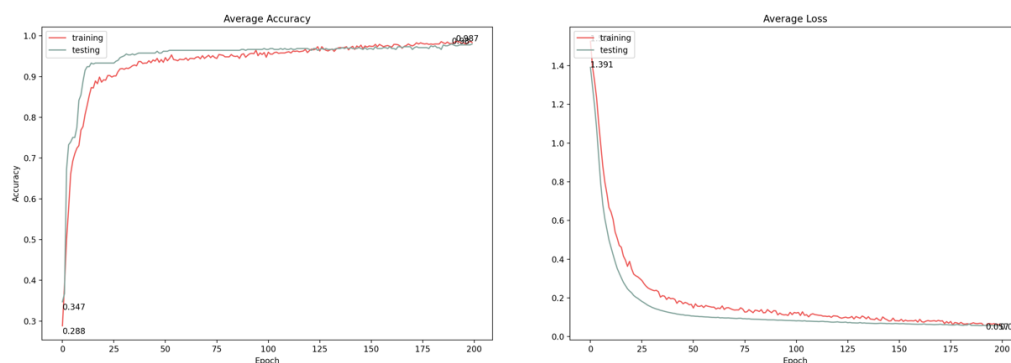

Figure 5.25: Experiment 10 average accuracy (left), average loss (right)

5.3.3.2. Experiment 11

Per the result of two layers of 32 neurons of convolutional layers and 256 hidden neurons for the final dense layer, the experiment model displays a high level of accuracy (98.7%). (Figure 5.26, right), shows the average loss for every epoch. After achieving a loss of 1.39 on the training set, the model rapidly decreased to approximately 0.20 within the first 25 epochs. The loss gradually decreased to approximately 0.057 after 25 cycles. Nevertheless, the accuracy of the model increased sharply during the first 20 epochs (Figure 5.26, left) to reach over 90% in the testing and training datasets. In the subsequent 180 epochs, the accuracy increased to 98.0%.

Code 11: Experiment 11 model structure

1. Namespace(batch_size=1, conv1d_activation='ReLU', data='DIT', dropout=True, edge_feat_dim=0, extract_features=False, feat_dim=0, fold=1, gm='DGCNN', hidden=256, latent_dim=[32, 32, 1], learning_rate=1e-05, max_lv=4, mode='cpu', num_class=0, num_epochs=200, out_dim=0, predict=False, printAUC=False, seed=1, sortpooling_k=0.6, test_number=449)
2. loading data
3. # classes: 5
4. # maximum node tag: 5
5. {4: 0, 0: 1, 1: 2, 3: 3, 2: 4}
6. # train: 1047, # test: 449

7. k used in SortPooling is: 81

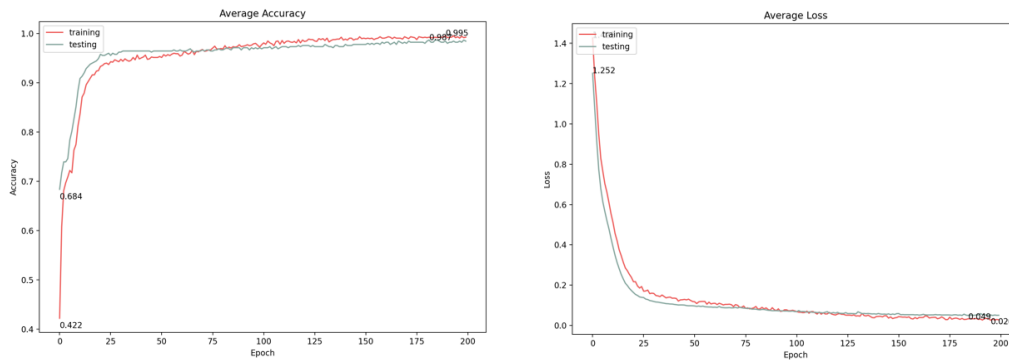

Figure 5.26: Experiment 11 average accuracy (left), average loss (right)

5.3.3.3. Experiment 12

Based on three convolutional layers of 64 neurons each and 256 hidden neurons for the dense layer, the experiment model has a high level of accuracy (98.0%). (Figure 5.27, right), illustrates the average loss of each epoch. Within the first 25 epochs of the model, the model had achieved a loss of 1.27 on the training set and quickly decreased to approximately 0.20. The loss then decreased gradually over the course of 25 cycles to approximately 0.051. However, the accuracy of the model increased sharply during the first 20 epochs (Figure 5.27, left) to reach over 90% in both the training and testing datasets. Following 180 epochs, the accuracy reached 98.0%.

Code 12: Experiment 12 model structure

1. Namespace(batch_size=1, conv1d_activation='ReLU', data='DIT', dropout=True, edge_feat_dim=0, extract_features=False, feat_dim=0, fold=1, gm='DGCNN', hidden=256, latent_dim=[64, 64, 64, 1], learning_rate=1e-05, max_lv=4, mode='cpu', num_class=0, num_epochs=200, out_dim=0, predict=False, printAUC=False, seed=1, sortpooling_k=0.6, test_number=449)
2. loading data
3. # classes: 5
4. # maximum node tag: 5
5. {4: 0, 0: 1, 1: 2, 3: 3, 2: 4}
6. # train: 1047, # test: 449
7. k used in SortPooling is: 81

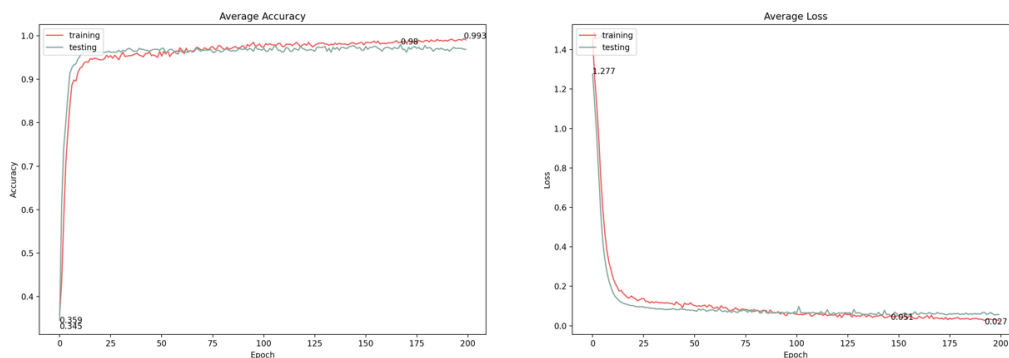

Figure 5.27: Experiment 12 average accuracy (left), average loss (right)

The best performance was obtained in Experiment 5. The experiment hyperparameter comprised two layers of 32 neurons of convolutional layers and 128 hidden neurons for the final dense layer. This hyperparameter experiment was selected for further analysis (Table 5.8).

5.3.3.4. Number of Epochs

The number of epochs represents the number of complete iterations through the training dataset. By increasing the number of epochs, the weights of the neural network will change more often, and the curve will move from an underfitting to an optimal to an overfitting curve. In the following four experiments (Experiments 15 to 18), the researcher used 100, 200, 300 and 500 epochs (Table 5.8) while maintaining two layers of 32 neurons of convolutional layers and 128 hidden neurons for the final dense layer.

Table 5.8: Tuning the number of epochs

Serial experiment No.	Number of epochs	Loss	Accuracy
Experiment 13	100	0.073	97.5%
Experiment 14	300	0.041	99.1%
Experiment 15	500	0.041	99.1%

5.3.3.4.1. Experiment 13

With two convolutional layers of 32 neurons each, 128 hidden neurons for the dense layer and 100 epochs, the experiment model achieves a high degree of accuracy (97.5%). (Figure 5.28, right), illustrates the average loss of each epoch. The model started with a loss of 1.32 on the training set and decreased quickly to approximately 0.20 over the first 20 epochs. Following this, the loss decreased gradually over the course of 25 cycles to approximately 0.073. However, it is noteworthy that the accuracy of the model increases significantly during the first fifteen epochs (Figure 5.28, left) to reach over 92% in both training and testing datasets. Following 180 epochs, the accuracy reached 97.5%.

Code 13: Experiment 13 model structure

```
1. Namespace(batch_size=1, conv1d_activation='ReLU', data='DIT', dropout=True, edge_feat_dim=0,
  extract_features=False, feat_dim=0, fold=1, gm='DGCNN', hidden=512, latent_dim=[32, 32, 1],
  learning_rate=1e-05, max_lv=4, mode='cpu', num_class=0, num_epochs=100, out_dim=0,
  predict=False, printAUC=False, seed=1, sortpooling_k=0.6, test_number=449)
2. loading data
3. # classes: 5
4. # maximum node tag: 5
5. {4: 0, 0: 1, 1: 2, 3: 3, 2: 4}
6. # train: 1047, # test: 449
7. k used in SortPooling is: 81
```

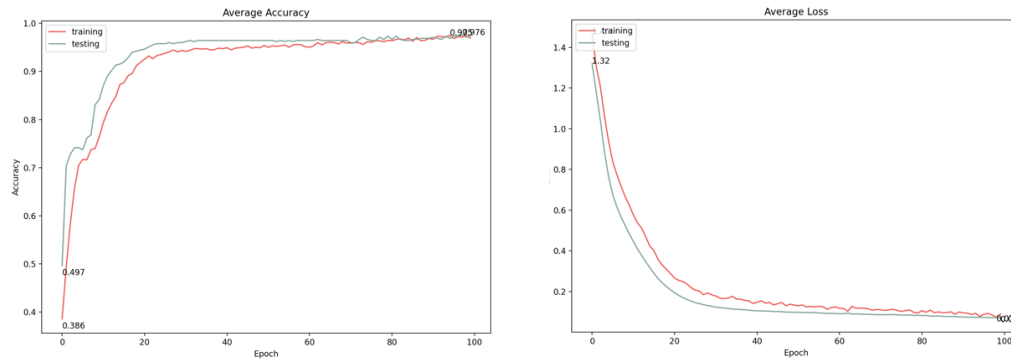



Figure 5.28: Experiment 13 average accuracy (left), average loss (right)

5.3.3.4.2. Experiment 14

Using 300 epochs, the experiment model achieved a high degree of accuracy (99.1%). (Figure 5.29, right), illustrates the average loss of each epoch. The model started with a loss of 1.32 on the training set and decreased quickly to approximately 0.20 over the first 20 epochs. Following this, the loss decreased gradually over the course of 25 cycles to approximately 0.041. Nevertheless, it should be noted that the accuracy of the model increased significantly for the first 20 epochs (Figure 5.29, left) to reach over 95% in both training and testing datasets. Following 180 epochs, the accuracy reached 99.1%. Although this model demonstrated the best accuracy and loss performance, it started to overfit after approximately 200 epochs. Consequently, this experiment did not undergo further consideration in the optimisation analysis.

Code 14: Experiment 14 model structure

1. Namespace(batch_size=1, conv1d_activation='ReLU', data='DIT', dropout=True, edge_feat_dim=0, extract_features=False, feat_dim=0, fold=1, gm='DGCNN', hidden=128, latent_dim=[32, 32, 1], learning_rate=1e-05, max_lv=4, mode='cpu', num_class=0, num_epochs=300, out_dim=0, predict=False, printAUC=False, seed=1, sortpooling_k=0.6, test_number=449)
2. loading data
3. # classes: 5
4. # maximum node tag: 5
5. {4: 0, 0: 1, 1: 2, 3: 3, 2: 4}
6. # train: 1047, # test: 449
7. k used in SortPooling is: 81

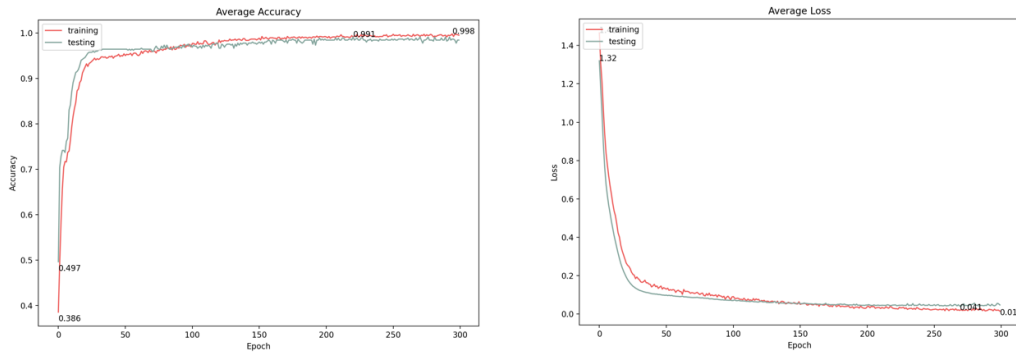

Figure 5.29: Experiment 14 average accuracy (left), average loss (right)

5.3.3.4.3. Experiment 15

Using 500 epochs, the experiment model achieved a high degree of accuracy (99.1%). (Figure 5.30, right), illustrates the average loss of each epoch. The model started with a loss of 1.32 on the training set and decreased quickly to approximately 0.20 over the first 20 epochs. Following this, the loss decreased gradually over the course of 25 cycles to approximately 0.041. On the other hand, it should be noted that the accuracy of the model increased significantly after the first 20 epochs (Figure 5.30, left) until it reaches above 95% in both training and testing datasets. Following 180 epochs, the accuracy reached 99.1%. While this model demonstrates the best accuracy and loss performance, it begins to overfit after approximately 200 epochs. Accordingly, this experiment will not undergo consideration during the optimisation process.

Code 15: Experiment 15 model structure

1. Namespace(batch_size=1, conv1d_activation='ReLU', data='DIT', dropout=True, edge_feat_dim=0, extract_features=False, feat_dim=0, fold=1, gm='DGCNN', hidden=128, latent_dim=[32, 32, 1], learning_rate=1e-05, max_lv=4, mode='cpu', num_class=0, num_epochs=500, out_dim=0, predict=False, printAUC=False, seed=1, sortpooling_k=0.6, test_number=449)
2. loading data
3. # classes: 5
4. # maximum node tag: 5
5. {4: 0, 0: 1, 1: 2, 3: 3, 2: 4}
6. # train: 1047, # test: 449
7. k used in SortPooling is: 81

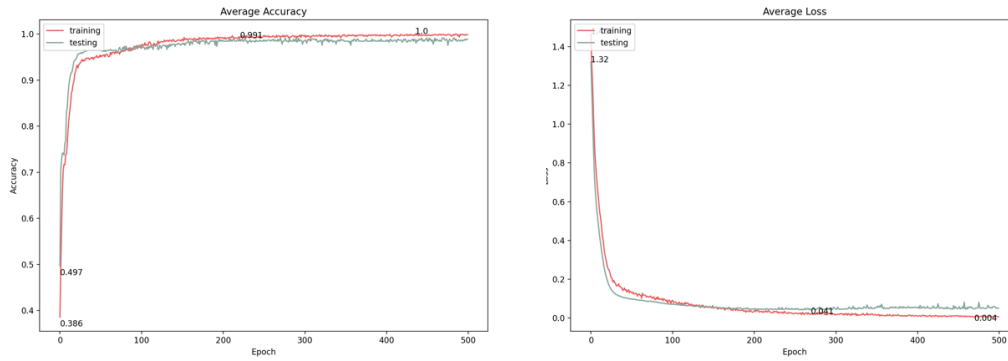

Figure 5.30: Experiment 15 average accuracy (left), average loss (right)

As yet the best performance was obtained in Experiment 5. The experiment hyperparameter comprised two layers of 32 neurons of convolutional layers, 128 hidden neurons for the final dense layer and 200 epochs. It was decided to perform further analysis using this hyperparameter experiment (Table 5.9).

5.3.3.5. Learning Rate

The learning rate represents the amount by which the weights of nodes are updated during training in convolutional neural networks. A value that proves too small may result in a long and tedious training process that will likely get stuck, while a value that proves too large may result in learning a suboptimal weight set too fast or an unstable training process. In the following four experiments (Experiments 19 to 22), the researcher used the following number of learning rate epochs: 1e-04, 1e-03 and 1e-02 (Table 5.9).

Table 5.9: Tuning the learning rate

Serial experiment No.	Learning rate number	Loss	Accuracy
Experiment 16	1e-04	0.044	99.1 %
Experiment 17	1e-03	0.54	99.1 %
Experiment 18	1e-02	1.31	41.6 %

5.3.3.5.1. Experiment 16

When using a lower learning rate, such as 1e-04, the experiment model achieves a high degree of accuracy (99.1%). The model started with a loss of 0.50 on the training set and decreased quickly to approximately 0.10 over the first ten epochs (Figure 5.31, right). Following this, the loss decreased gradually over the course of 25 cycles to approximately 0.041. On the other hand, it should be noted that the accuracy of the model increases significantly after the first five epochs (Figure 5.31, left) until it reaches above 95% in training and testing datasets. Following 180 epochs, the accuracy reached 99.1%. This has so far proven to be the best DGCNN model.

Code 16: Experiment 16 model structure

1. Namespace(batch_size=1, conv1d_activation='ReLU', data='DIT', dropout=True, edge_feat_dim=0, extract_features=False, feat_dim=0, fold=1, gm='DGCNN', hidden=128, latent_dim=[32, 32, 1], learning_rate=0.0001, max_lv=4, mode='cpu', num_class=0, num_epochs=200, out_dim=0, predict=False, printAUC=False, seed=1, sortpooling_k=0.6, test_number=449)
2. loading data
3. # classes: 5
4. # maximum node tag: 5
5. {4: 0, 0: 1, 1: 2, 3: 3, 2: 4}
6. # train: 1047, # test: 449
7. k used in SortPooling is: 81

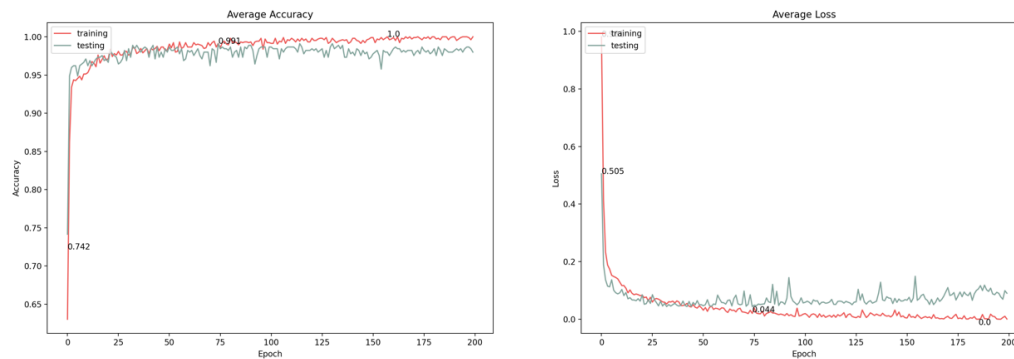

Figure 5.31: Experiment 16 average accuracy (left), average loss (right)

5.3.3.5.2. Experiment 17

Using different learning rates, such as 1e-03, the experiment model achieves a high degree of accuracy (99.1). However, the average losses proved unacceptably high. In the training set, the model started with a loss of 0.64 and fluctuated to reach a loss of 0.54 (Figure 5.32, right). On the other hand, it should be noted that the accuracy of the model increases significantly after the first five epochs until it reaches above 95% in both training and testing datasets (Figure 5.32, left). Following 180 epochs, the accuracy reached 99.1%. Although this model demonstrates the best accuracy and loss performance, its performance fluctuated, preventing it from undergoing consideration for optimisation.

Code 17: Experiment 17 model structure

1. Namespace(batch_size=1, conv1d_activation='ReLU', data='DIT', dropout=True, edge_feat_dim=0, extract_features=False, feat_dim=0, fold=1, gm='DGCNN', hidden=128, latent_dim=[32, 32, 1], learning_rate=0.001, max_lv=4, mode='cpu', num_class=0, num_epochs=200, out_dim=0, predict=False, printAUC=False, seed=1, sortpooling_k=0.6, test_number=449)
2. loading data
3. # classes: 5
4. # maximum node tag: 5
5. {4: 0, 0: 1, 1: 2, 3: 3, 2: 4}
6. # train: 1047, # test: 449
7. k used in SortPooling is: 81

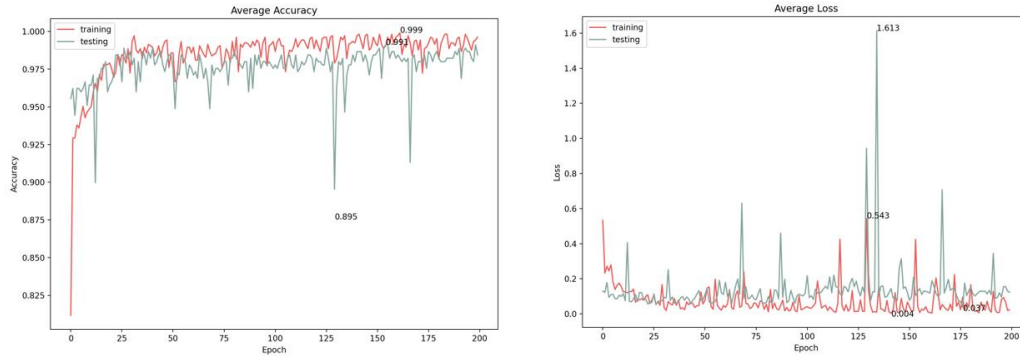

Figure 5.32: Experiment 17 average accuracy (left), average loss (right)

5.3.3.5.3. Experiment 18

Using a 1e-02 learning rate, the experiment model falls dramatically to reach 41.6% accuracy and continues to fall below 30% (Figure 5.33, left). Additionally, the average loss on the training dataset is 1.33 and falls to approximately 1.35 (Figure 5.33, right). Based on the testing dataset, the average loss began at approximately 1.1 and then increased to 1.33. The model's performance fluctuated highly, and the model presented an unacceptable performance, which prevented it from undergoing optimisation.

Code 18: Experiment 18 model structure

1. Namespace(batch_size=1, conv1d_activation='ReLU', data='DIT', dropout=True, edge_feat_dim=0, extract_features=False, feat_dim=0, fold=1, gm='DGCNN', hidden=128, latent_dim=[32, 32, 1], learning_rate=0.01, max_lv=4, mode='cpu', num_class=0, num_epochs=200, out_dim=0, predict=False, printAUC=False, seed=1, sortpooling_k=0.6, test_number=449)
2. loading data
3. # classes: 5
4. # maximum node tag: 5
5. {4: 0, 0: 1, 1: 2, 3: 3, 2: 4}
6. # train: 1047, # test: 449
7. k used in SortPooling is: 81

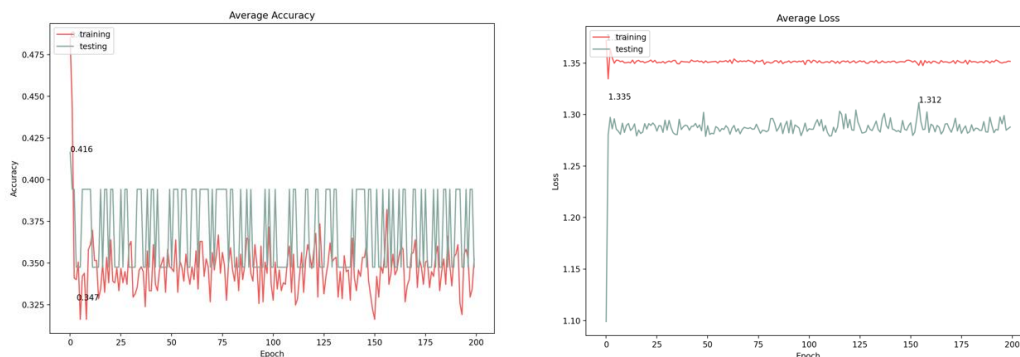

Figure 5.33: Experiment 18 average accuracy (left), average loss (right)

5.3.3.6. Batch Size

In machine learning, batch size refers to the number of data used in one iteration of the training process. Moreover, the batch size of gradient descent in convolutional neural networks controls the number of training samples to iterate before the model’s internal parameters are updated. The batch size configures as follows:

1. Batch mode: the batch size equals the total dataset, thus ensuring that epoch values and iterations are equivalent.
2. Mini-batch mode: each batch size exceeds one, but not more than the size of the total dataset. Typically, a number can be divided into the total dataset size.
3. Stochastic mode: a batch size of one. This means that the gradient and the neural network parameters are updated after each sample.

Table 5.10: Tuning the batch size

Serial experiment No.	Batch size	Time processing	Loss	Accuracy
Experiment 19	1	12:30:50	0.044	99.1%
Experiment 20	2	08:17:71	0.045	97.8%
Experiment 21	5	03:58:76	0.077	97.1%
Experiment 22	10	02:54:85	0.093	96.4%
Experiment 23	20	02:04:73	0.101	96.4%

5.3.3.6.1. Experiment 19

A similar set of hyperparameters is used in Experiments 5. These results undergo discussion in Experiments 5. This experiment takes 12.5 minutes, which represents the longest total processing time. Nevertheless, this time frame proves acceptable in the area of neural networks.

5.3.3.6.2. Experiment 20

Using two batch sizes, the experiment model achieves a high degree of accuracy (97.8%) (Figure 5.34, right). However, the average losses were unacceptably high. In the training set, the model started with a loss of 0.64 and fluctuated to reach a loss of 0.54. On the other hand, it should be noted that the accuracy of the model increases significantly after the first five epochs (Figure 5.34, left) until it reaches above 95% in training and testing datasets. Following 180 epochs, the accuracy reached 99.1%. Although this model demonstrates the best accuracy and loss performance, its performance fluctuated, preventing it from undergoing consideration for optimisation.

Code 20: Experiment 20 model structure

1. Namespace(batch_size=2, conv1d_activation='ReLU', data='DIT', dropout=True, edge_feat_dim=0, extract_features=False, feat_dim=0, fold=1, gm='DGCNN', hidden=128, latent_dim=[32, 32, 1], learning_rate=1e-04, max_lv=4, mode='cpu', num_class=0, num_epochs=200, out_dim=0, predict=False, printAUC=False, seed=1, sortpooling_k=0.6, test_number=449)
2. loading data
3. # classes: 5
4. # maximum node tag: 5
5. {4: 0, 0: 1, 1: 2, 3: 3, 2: 4}
6. # train: 1047, # test: 449
7. k used in SortPooling is: 81

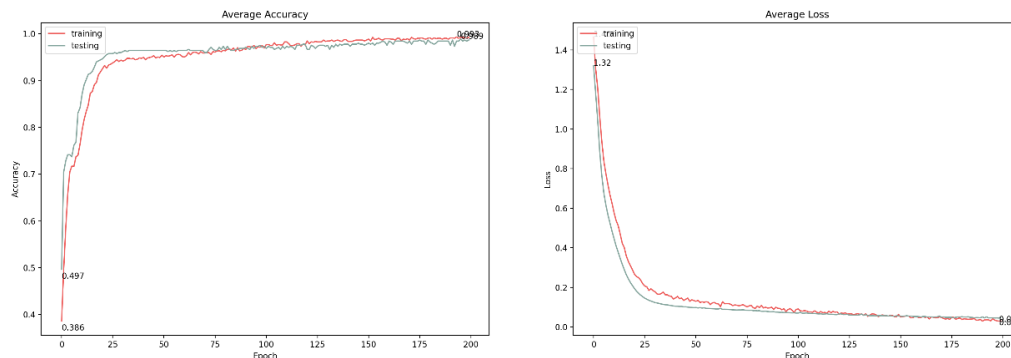

Figure 5.34: Experiment 20 average accuracy (left), average loss (right)

5.3.3.6.3. Experiment 21

With a five-batch size, the experimental model still achieves high accuracy (97.1%) (Figure 5.35, left). Over the first 50 iterations, the model had a loss of 1.60 and decreased quickly to approximately 0.77 (Figure 5.35, right). In contrast, it should be noted that the accuracy of the model significantly increases after the first 50 epochs until it reaches over 95% for training and testing datasets. The accuracy reached 97.1% after 150 epochs. This experiment takes approximately four minutes, which is faster than Experiments 19 and 20. The significantly lower processing time affects the model's accuracy.

Code 21: Experiment 21 model structure

1. Namespace(batch_size=5, conv1d_activation='ReLU', data='DIT', dropout=True, edge_feat_dim=0, extract_features=False, feat_dim=0, fold=1, gm='DGCNN', hidden=128, latent_dim=[32, 32, 1], learning_rate=1e-04, max_lv=4, mode='cpu', num_class=0, num_epochs=200, out_dim=0, predict=False, printAUC=False, seed=1, sortpooling_k=0.6, test_number=449)
2. loading data
3. classes: 5
4. maximum node tag: 5
5. {4: 0, 0: 1, 1: 2, 3: 3, 2: 4}
6. train: 1047, # test: 449
7. used in SortPooling is: 81

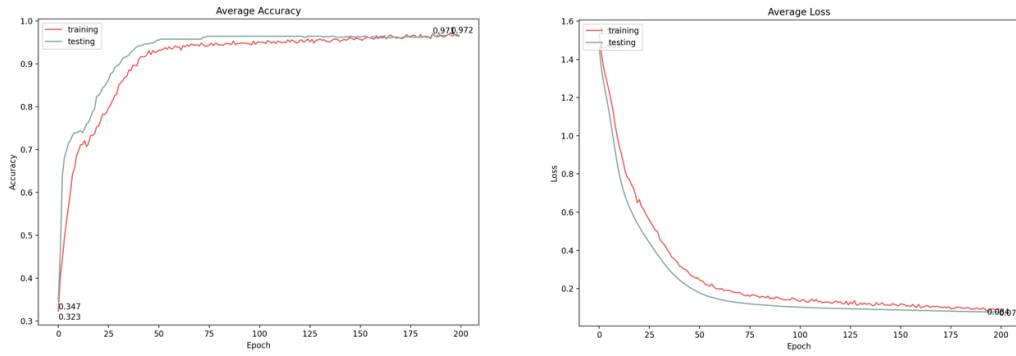

Figure 5.35: Experiment 21 average accuracy (left), average loss (right)

5.3.3.6.4. Experiment 22

With a ten-batch size, the experimental model achieves high accuracy (96.4 %) (Figure 5.36, left). Over the first 75 iterations, the model experienced a loss of 1.60, then decreased quickly to approximately 0.93 (Figure 5.36, left). In contrast, it should be noted that the accuracy of the model significantly increases in the first 75 epochs until it exceeds 95% for training and testing datasets. The accuracy reached 96.4% after 100 epochs. This experiment takes approximately three minutes, which is faster than Experiments 19, 20 and 21. Although this processing time is significantly less, it affects the accuracy of the model. For this reason, it plays no part in the experiments.

Code 22: Experiment 22 model structure

1. Namespace(batch_size=10, conv1d_activation='ReLU', data='DIT', dropout=True, edge_feat_dim=0, extract_features=False, feat_dim=0, fold=1, gm='DGCNN', hidden=128, latent_dim=[32, 32, 1], learning_rate=1e-04, max_lv=4, mode='cpu', num_class=0, num_epochs=200, out_dim=0, predict=False, printAUC=False, seed=1, sortpooling_k=0.6, test_number=449)
2. loading data
3. # classes: 5
4. maximum node tag: 5
5. 4: 0, 0: 1, 1: 2, 3: 3, 2: 4}
6. train: 1047, # test: 449
7. k used in SortPooling is: 81

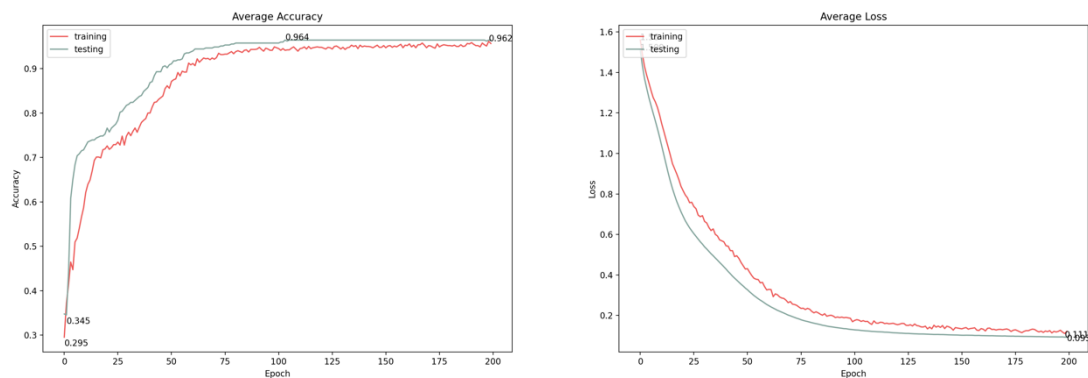

Figure 5.36: Experiment 22 average accuracy (left), average loss (right)

5.3.3.6.5. Experiment 23

Finally, with a 20-batch size, the experimental model still achieves high accuracy (96.4) (Figure 5.37, left). However, the batch size clearly affects both losses and accuracy in this experiment. Over the first 75 iterations, the model experienced a loss of 1.60, then decreased quickly to approximately 0.45 (Figure 5.37, right). In contrast, it should be noted that the accuracy of the model significantly increases in the first 75 epochs until it exceeds 90% for training and testing datasets. Although this processing time is significantly less (Table 5.10), it affects the accuracy of the model. For this reason, it plays no part in the experiments.

Code 23: Experiment 23 model structure

```

1. Namespace(batch_size=20, conv1d_activation='ReLU', data='DIT', dropout=True,
edge_feat_dim=0, extract_features=False, feat_dim=0, fold=1, gm='DGCNN', hidden=128,
latent_dim=[32, 32, 1], learning_rate=1e-04, max_lv=4, mode='cpu', num_class=0,
num_epochs=200, out_dim=0, predict=False, printAUC=False, seed=1, sortpooling_k=0.6,
test_number=449)
2. loading data
3. # classes: 5
4. # maximum node tag: 5
5. {4: 0, 0: 1, 1: 2, 3: 3, 2: 4}
6. # train: 1047, # test: 449
7. k used in SortPooling is: 81
    
```

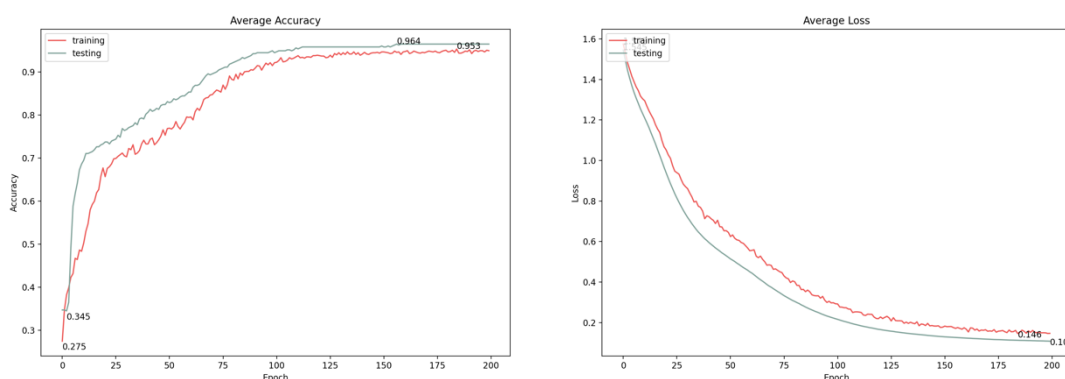

Figure 5.37: Experiment 23 average accuracy (left), average loss (right)

5.3.4. Testing the Deep Graph Convolutional Neural Network (DGCNN)

Architecture

After 23 experiments, the best model parameter became clear. The optimal parameters of the model comprised two layers of convolutional layers, each layer having 32 neurons, 128 hidden layers for the final dense layers, 200 epochs, 1-e4 learning rate and a batch size of 1. The final model achieved 99.1% accuracy with an average loss of 0.044 (Figure 5.38). The best-performing model was then saved and tested on the test set after the training dataset tuned the hyperparameter.

Chapter 5: Machine Learning Models to Cluster and Classify Building and Ground Relationship

Code: Saved best model

1. Namespace(batch_size=1, conv1d_activation='ReLU', data='DIT', dropout=True, edge_feat_dim=0, extract_features=False, feat_dim=0, fold=1, gm='DGCNN', hidden=128, latent_dim=[32, 32, 1], learning_rate=0.0001, max_lv=4, mode='cpu', num_class=0, num_epochs=200, out_dim=0, predict=False, printAUC=False, seed=1, sortpooling_k=0.6, test_number=449)
2. loading data
3. # classes: 5
4. # maximum node tag: 5
5. {4: 0, 0: 1, 1: 2, 3: 3, 2: 4}
6. # train: 1047, # test: 449
7. k used in SortPooling is: 81

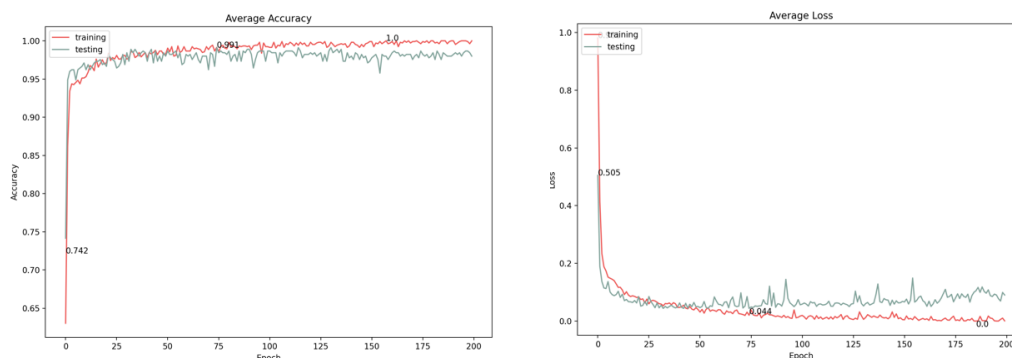

Figure 5.38: Test of the saved model using unseen data, average accuracy (left), average loss (right)

For testing the model, the researcher utilised unseen 640-test data. The process started as the following:

1. First, the 'run_DGCNN.sh' file requires modification. In line 17, add the parameter predict = True. All other parameters should remain unchanged.

```
1. #!/bin/bash
2. # input arguments
3. DATA="${1-MUTAG}" # MUTAG, ENZYMES, NCI1, NCI109, DD, PTC, PROTEINS, COLLAB, IMDBBINARY,
  IMDBMULTI
4. fold=${2-1} # which fold as testing data
5. test_number=${3-0} # if specified, use the last test_number graphs as test data
6. # general settings
7. gm=DGCNN # model
8. gpu_or_cpu=cpu
9. GPU=0 # select the GPU number
10. CONV_SIZE="32-32-32-1"
11. sortpooling_k=0.6 # If k <= 1, then k is set to an integer so that k% of graphs have nodes less than this
  integer
12. 1FP_LEN=0 # final dense layer's input dimension, decided by data
13. n_hidden=128 # final dense layer's hidden size
14. bsize=50 # batch size, set to 50 or 100 to accelerate training
15. dropout=True
16. predict=False
17. # dataset-specific settings
18. case ${DATA} in
19. *)
```

2. Add the following line to the bottom of 'run_DGCNN.sh': -predict \$predict / below the CUDA_VISIBLE_DEVICES list.

```
1. CUDA_VISIBLE_DEVICES=${GPU} python main.py \
```

```
2. -seed 1 \  
3. -data $DATA \  
4. -fold $fold \  
5. -learning_rate $learning_rate \  
6. -num_epochs $num_epochs \  
7. -hidden $n_hidden \  
8. -latent_dim $CONV_SIZE \  
9. -sortpooling_k $sortpooling_k \  
10. -out_dim $FP_LEN \  
11. -batch_size $bsize \  
12. -gm $gm \  
13. -mode $gpu_or_cpu \  
14. -dropout $dropout \  
15. -predict $predict \  
16. -test_number ${test_number}
```

3. The name of the saved model for use as a prediction should be the same as in "main.py" line 210

```
2. if cmd_args.predict:  
3. classifier = Classifier()  
4. if cmd_args.mode == 'gpu':  
5. classifier = classifier.cuda()  
6. model_name = 'saved_model/test1.bin'  
7. classifier.load_state_dict(torch.load(model_name))
```

4. The code can now be run in the terminal. Similar to the train mode, enter the following command:

```
1. pytorch_DGCNN-master % ./run_DGCNN.sh DIT 1 640
```

5. Upon completing the code, the terminal will print the results for the prediction along with the probability distribution of the classifications present in the data.

```
1. Namespace(batch_size=1, conv1d_activation='ReLU', data='DIT', dropout=True, edge_feat_dim=0, extract_features=False, feat_dim=0, fold=1, gm='DGCNN', hidden=128, latent_dim=[32, 32, 1], learning_rate=0.0001, max_lv=4, mode='cpu', num_class=0, num_epochs=200, out_dim=0, predict=True, printAUC=False, seed=1, sortpooling_k=0.6, test_number=39)  
2. loading data  
3. # classes: 5  
4. # maximum node tag: 5  
5. {4: 0, 0: 1, 1: 2, 3: 3, 2: 4}  
6. # train: 1936, # test: 39  
7. k used in SortPooling is: 81  
8. Initialising DGCNN  
9. {4: 0, 0: 1, 1: 2, 3: 3, 2: 4}  
10. [[0. 1. 0. 0. 0. ]  
11. [0. 0. 1. 0. 0. ]  
12. [0. 0. 1. 0. 0. ]  
13. [0. 1. 0. 0. 0. ]  
14. [1. 0. 0. 0. 0. ]  
15. ..  
16. [0.0182 0. 0. 0. 0.9818]  
17. [1. 0. 0. 0. 0. ]  
18. [1. 0. 0. 0. 0. ]  
19. [0. 0. 1. 0. 0. ]  
20. [0. 1. 0. 0. 0. ]  
21. Predictions for DIT are saved in data/DIT_pred.txt
```

Chapter 5: Machine Learning Models to Cluster and Classify Building and Ground Relationship

The (Table 5.11) below outlines this process, which includes the index location, the class and a graph representative of each line, and each column features the likelihood that it will be labelled. Below are ten examples of the 640 unseen datasets. All ten examples were 100% correctly predicted; however, one example was predicted with 98% accuracy in the right class.

Table 5.11: Ten examples of unseen datasets

Index location	0	1	2	3	4
Classification	4	0	1	3	2
A graph is represented by each line, and each column is the probability that it will be labelled.	0.	1.	0.	0.	0.
	0.	0.	1.	0.	0.
	0.	0.	1.	0.	0.
	0.	1.	0.	0.	0.
	1.	0.	0.	0.	0.
	0.0182	0.	0.	0.	0.9818
	1.	0.	0.	0.	0.
	1.	0.	0.	0.	0.
	0.	0.	1.	0.	0.
	0.	1.	0.	0.	0.

Confusion matrices evaluate the performance of classification models, where (N) represents the number of target classes. In the matrix, the target values undergo a comparison with the values predicted by the machine learning model. Confusion matrices allow the comparison of properly classified examples against those that were misclassified, providing insight into the performance of the classifier.

The matrix featured 640 predicted data points high accuracy in both classes (Table 5.12). In total, 633 examples were assigned to the correct class, but only seven were predicted incorrectly. The seven examples were accumulated in Classes 2 and 4. Two of them were incorrectly classified as Class 4, while their values require classification as Class 2. Moreover, five of them were incorrectly classified as Class 2, while their actual values require classification as Class 4. Consequently, it remains crucial to note that the accuracy of Classes 0, 1 and 3 was accurate. Despite the seven errors being limited to Classes 2 and 4, the model was performed with high accuracy in both classes.

Table 5.12: A confusion matrix of 640 unseen datasets

		Actual Values				
		Separation	Separation with plinth	Adherence	Adherence with plinth	Interlock
		Class 0	Class 1	Class 2	Class 3	Class 4
Predicted Values	Class 0	233	0	0	0	0
	Class 1	0	205	0	0	0
	Class 2	0	0	28	0	5
	Class 3	0	0	0	40	0
	Class 4	0	0	2	0	127

5.3.5. Unbalanced Data (Under Sampling Approach)

The created dataset was unbalanced, which often occurs for classification exercises. Furthermore, the synthetic data can be regarded as homogeneous within the same category. Nevertheless, to demonstrate the impact of under-sampling on classification performance, the researcher reanalysed the final model and tested it with under-sampling. According to (Table 5.13), the total amount of the dataset was 2,136. The separation data amounted to 759, separation with plinth data amounted to 747, Adherence amounted to 102, Adherence plinth amounted to 96, and the interlock dataset amounted to 432.

In this test, the researcher used an under-sampling technique to test the model’s performance. The researcher randomly chose to cut off the separation dataset from 759 to 270, similar to the separation with the plinth dataset from 747 to 270. Moreover, the interlock dataset was cut down from 432 to 198 (Table 5.14). Using this approach makes the data more balanced.

Table 5.13: The original dataset used in optimising the DGCNN

	Flat Ground	Slope Ground	Level Ground	Total
Separation	90	267	402	759
Separation plinth	90	255	402	747
Adherence	12	36	54	102
Adherence plinth	12	30	54	96
Interlock	36	72	324	432
	240	660	1236	
			2136	

Table 5.14: New balanced dataset used to demonstrate the unbalanced data effect

	Flat Ground	Slope Ground	Level Ground	Total
Separation	90	90	90	270
Separation plinth	90	90	90	270
Adherence	12	36	54	102
Adherence plinth	12	30	54	96
Interlock	36	72	90	198
	240	318	378	
			936	

The same hyperparameters for the best-saved model comprised two convolutional layers, each layer having 32 neurons, 128 hidden layers, 200 epochs, 1-e4 learning rate and a batch size of 1. The model achieved a high accuracy of 95.7%, with a loss of 1.07. However, closer examination of (Figure 5.39) reveals that the model fluctuated and did not perform consistently. Accordingly, changing only the learning rate from 1-e4 to 1-e5 resulted in more stable performance. Based on this change, the model achieved an accuracy rating of 95.7%,

Chapter 5: Machine Learning Models to Cluster and Classify Building and Ground Relationship

with a loss of 0.128. This model showed that the unbalanced data had a minimal effect, which proved 3.4% less than the best-performed model (Figure 5.40).

Code: Experiment under-sampling data model structure

1. Namespace(batch_size=1, conv1d_activation='ReLU', data='BALA', dropout=True, edge_feat_dim=0, extract_features=False, feat_dim=0, fold=1, gm='DGCNN', hidden=128, latent_dim=[32, 32, 1], learning_rate=0.0001, max_lv=4, mode='cpu', num_class=0, num_epochs=200, out_dim=0, predict=False, printAUC=False, seed=1, sortpooling_k=0.6, test_number=280)
2. loading data
3. # classes: 5
4. # maximum node tag: 5
5. {0: 0, 2: 1, 4: 2, 1: 3, 3: 4}
6. # train: 656, # test: 280
7. k used in SortPooling is: 72

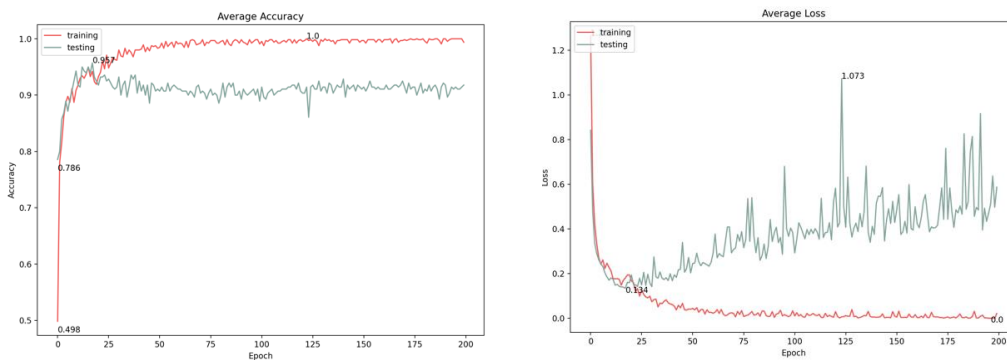

Figure 5.39: Experiment of under-sampling approach average accuracy (left), average loss (right)

Code: Experiment under-sampling 2 data model structure

1. Namespace(batch_size=1, conv1d_activation='ReLU', data='BALA', dropout=True, edge_feat_dim=0, extract_features=False, feat_dim=0, fold=1, gm='DGCNN', hidden=128, latent_dim=[32, 32, 1], learning_rate=1e-05, max_lv=4, mode='cpu', num_class=0, num_epochs=200, out_dim=0, predict=False, printAUC=False, seed=1, sortpooling_k=0.6, test_number=280)
2. loading data
3. # classes: 5
4. # maximum node tag: 5
5. {0: 0, 2: 1, 4: 2, 1: 3, 3: 4}
6. # train: 656, # test: 280
7. k used in SortPooling is: 7

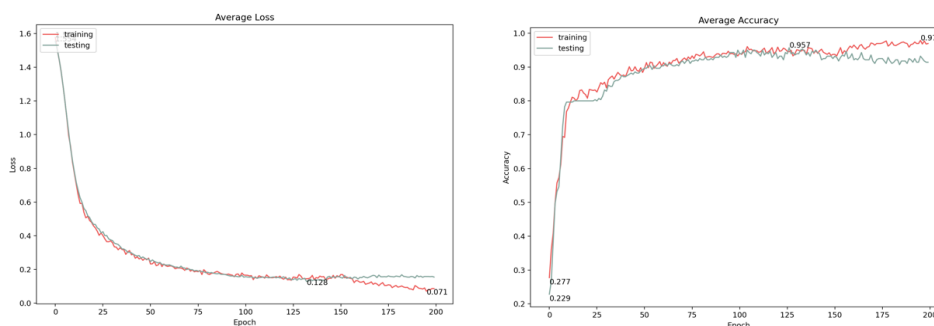

Figure 5.40: Experiment of under-sampling 2 approach average accuracy (left), average loss (right)

5.3.6. Prediction of New Building and Ground Relationship Scenarios

The best-trained model was saved after the DGCNN underwent training and validation. In this section, the researcher created a set of new test scenarios that did not form part of the data used to build the DGCNN model, using a Grasshopper definition (Figure 5.41). The new design considers several new building and ground precedents. The new scenario adopted similar rules and comparable node categories, although it employed more varied approaches on the ground.

The 12 new architectural precedents were conducted and fed into the best-saved model. The first set of scenarios was designed on flat ground (FG). The additional set of scenarios was designed on sloped ground (SG). The final set of scenarios was designed on level ground (LG). Despite all scenarios having different topological elements compared with the trained ones, each new scenario was predicted successfully (Table 5.15).

Table 5.15: Twelve examples of new scenarios

No. of Scenario	The Ground	Class 0	Class 1	Class 2	Class 3	Class 4	Prediction True /False
		Separation	Separation with plinth	Adherence	Adherence with plinth	Interlock	
1	Flat	0%	100%	0%	0%	0%	True
2		0%	0%	0%	100%	0%	True
3		0%	0%	13.9%	0%	86.1%	True
4		100%	0%	0%	0%	0%	True
5	Sloped	0%	0%	0%	0%	100%	True
6		100%	0%	0%	0%	0%	True
7		0%	0%	0%	100%	0%	True
8		0%	0%	1%	0%	99%	True
9	Level	0%	100%	0%	0%	0%	True
10		0%	0%	0%	100%	0%	True
11		0%	0%	0%	0%	99.9%	True
12		0%	100%	0%	0%	0%	True

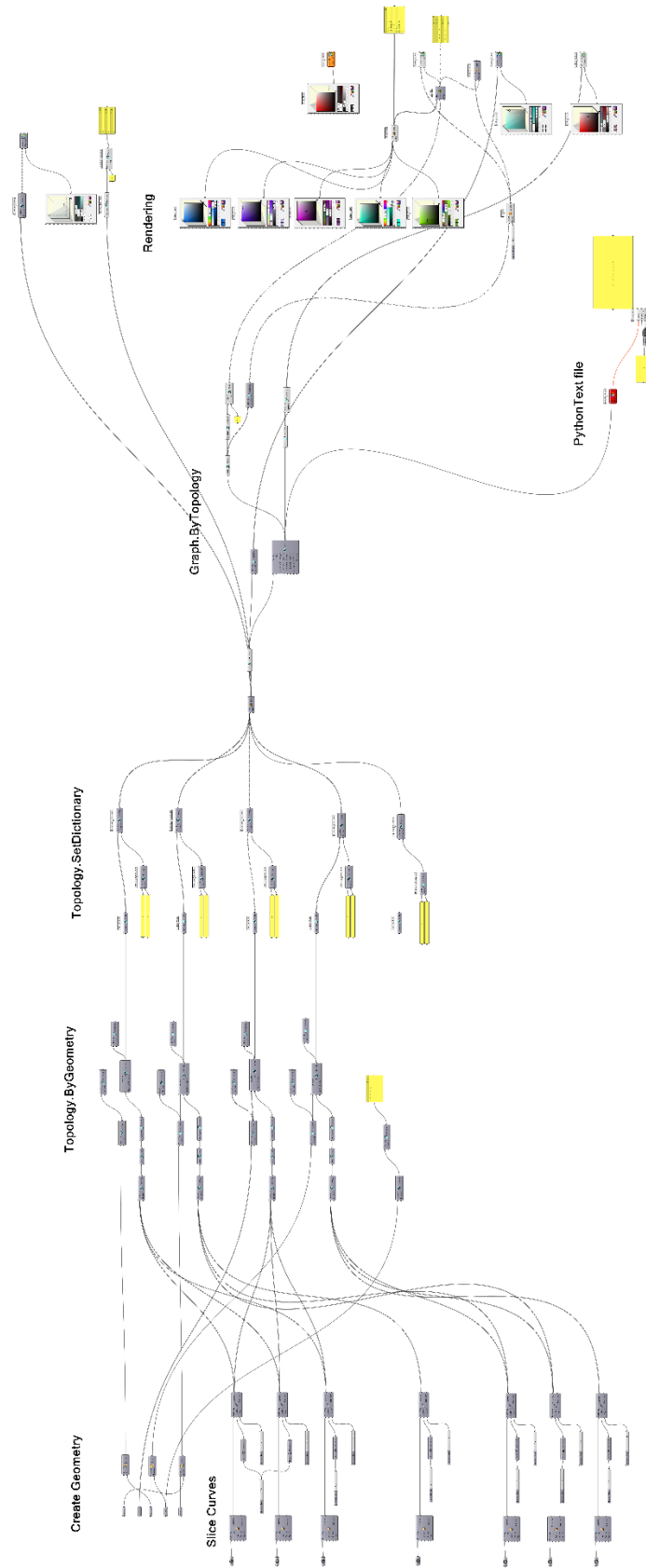

Figure 5.41: Grasshopper definition to create new building and ground scenarios

Chapter 5: Machine Learning Models to Cluster and Classify Building and Ground Relationship

(Figure 5.42, left) illustrates Scenario 1 with two cores, and the models did not undergo training to determine the topology of the two cores; DGCNN predicted this case as a separation with a plinth of 100% true. With respect to Scenario 2 (Figure 5.42, right), the model has an L-shaped building that has not been pre-trained to recognise this topology. Even so, the model successfully predicted the building and ground relationship as adherence with a plinth with 100% accuracy. Scenarios 3 and 4 (Figure 5.43) had two buildings at different heights from the ground, with both successfully classified as separation and interlock with 86.1% and 100% accuracy.

In Scenario 5 (Figure 5.44, left), the two buildings have a different interlock level with the ground, with the case predicted successfully with 100% accuracy as an interlock. In Scenario 6 (Figure 5.44, right), the columns are set into the sloped ground. The two buildings are separated from each other, and the model was not previously trained. Nevertheless, the model successfully predicted the new precedents with 100% accuracy. In Scenario 7 (Figure 5.45, left), the plinth followed the ground's slope, with the model predicting the case with 100% accuracy. In Scenario 8 (Figure 5.45, right), the building dips completely underground, and the model predicted this case with 99% accuracy.

The building has four cores in Scenario 9 (Figure 5.46, left). In the case of level ground, the building is partially set on the plinth, while other portions are raised above the ground. The model was classified successfully as Class 1 (separation with plinth) with 100% accuracy. The next scenario 10 shows a building situated on a plinth and then on the ground with differing heights (Figure 5.46, right). The model was classified as Class 3 (adherence to plinth) with 100% accuracy. Moreover, the scenario 11 was classified correctly and placed with Class 4 interlock with the ground (Figure 5.47, left). Finally, the last scenario 12 was classified correctly and placed in Class 1 due to its separation from the ground (Figure 5.47, right).

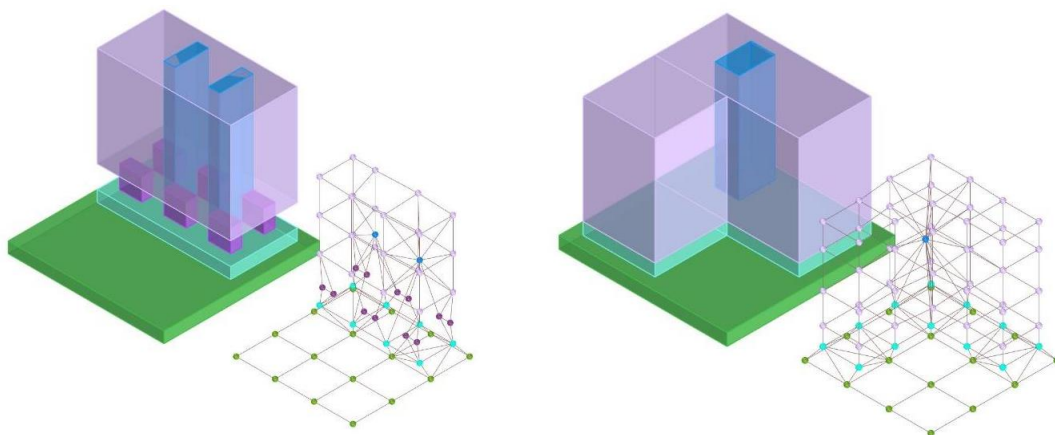

Figure 5.42: Scenario 1 (left), Scenario 2 (right)

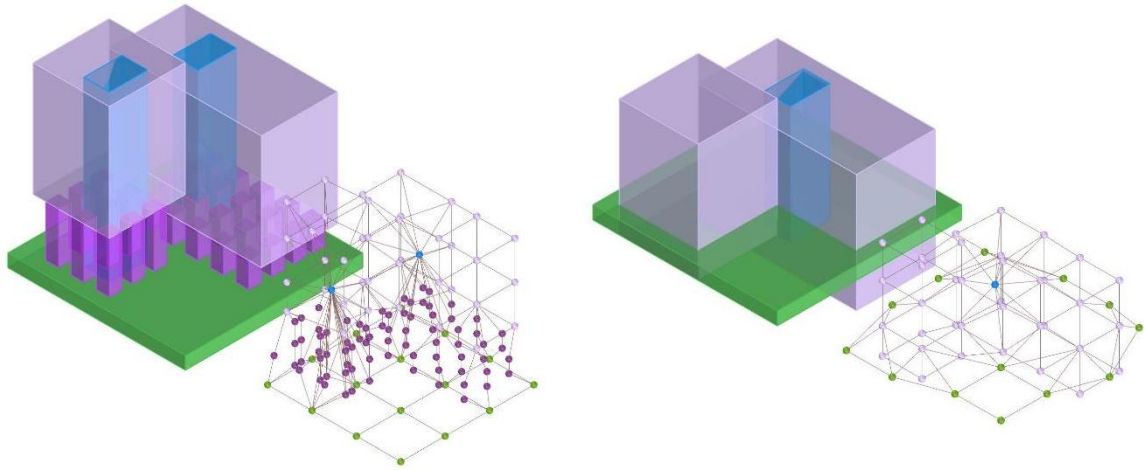

Figure 5.43: Scenario 3 (left), Scenario 4 (right)

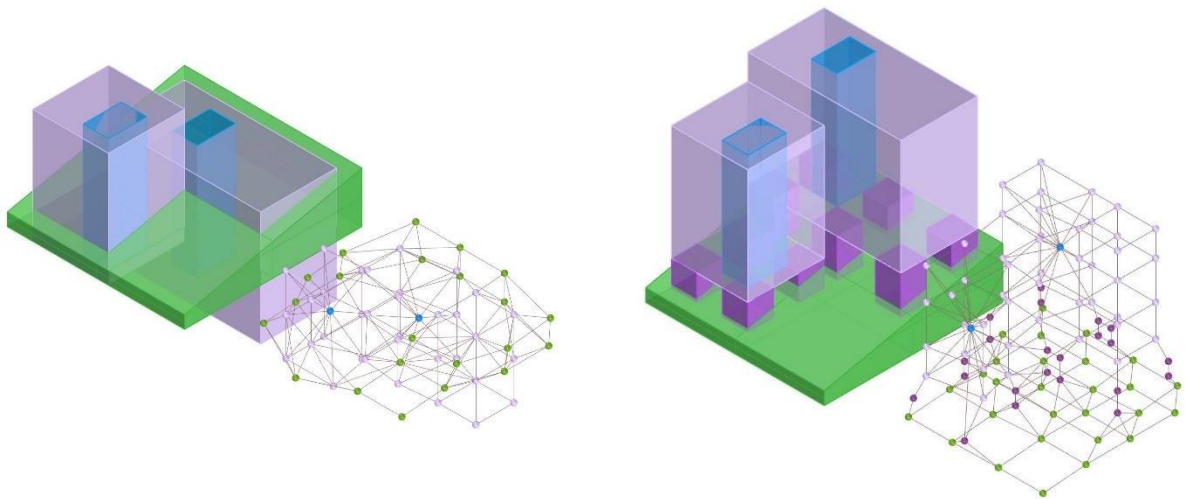

Figure 5.44: Scenario 5 (left), Scenario 6 (right)

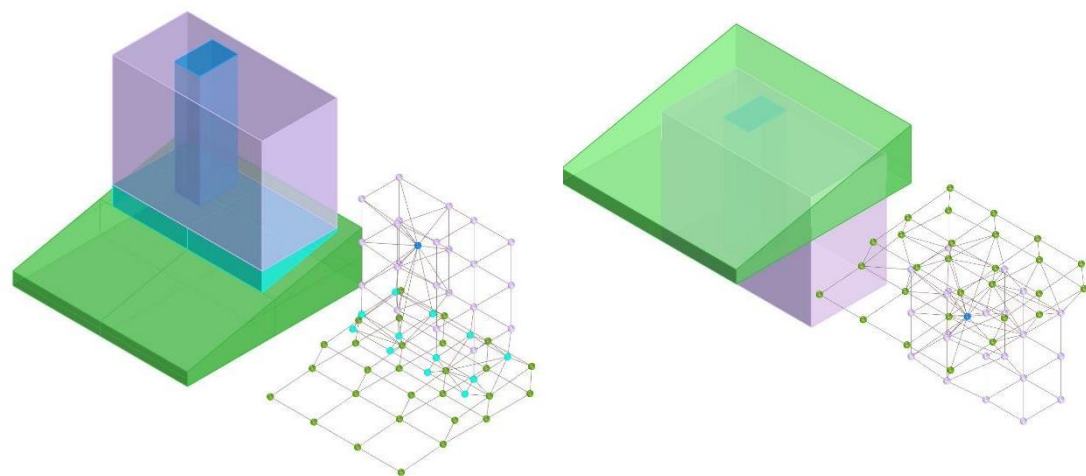

Figure 5.45: Scenario 7 (left), Scenario 8 (right)

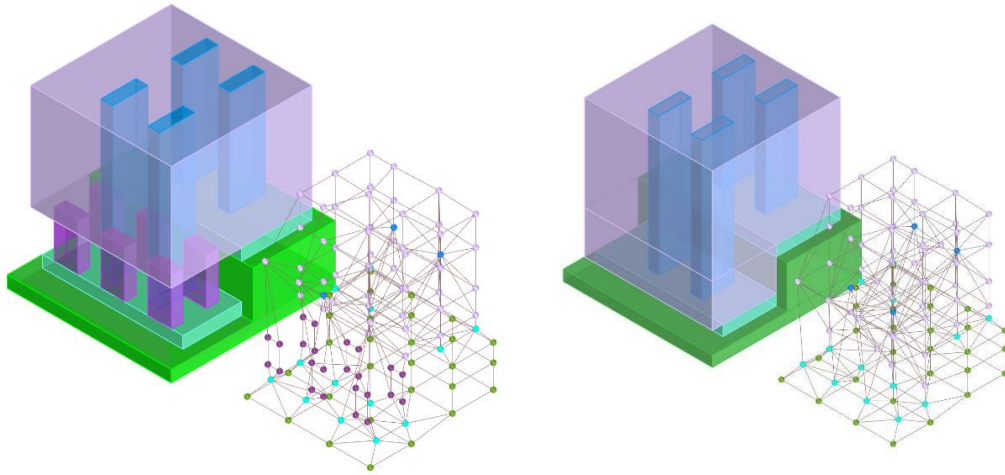

Figure 5.46: Scenario 9 (left), Scenario 10 (right)

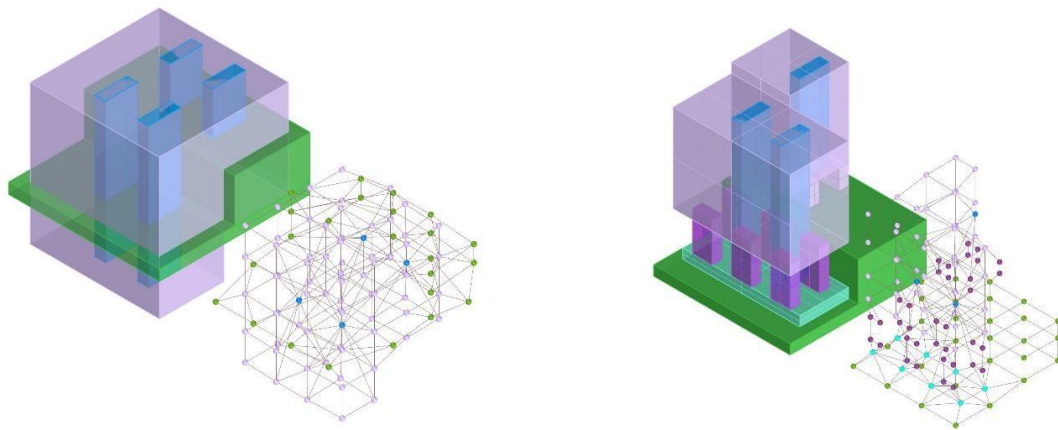

Figure 5.47: Scenario 11 (left), Scenario 12 (right)

5.3.7. Applying the Different Deep Graph Neural Network (Deep Graph Library (DGL))

In this section, the researcher applies a different Deep Graph Neural Network, namely, the Deep Graph Library (DGL). Using different machine learning algorithms, this section evaluates the results of the same dataset. The results of DGL reach 98.4% accuracy performance with 0.1 error loss (Figure 5.48). The DGL structure was developed as part of Topologic by Professor Wassim Jabi, in Blender, a free and open-source 3D computer programme, and its plugin (Sverchok), an advanced parametric tool. The best structure performance of the DGL comprised 32 hidden layers, Adam optimizer, the Conv layer type SAGEConv, a train and test split ratio of 80-20%, MaxPooling layer, loss function is, 100 epochs, a batch size of 5 and a learning rate of 0.001 (Figure 5.49).

The best model was saved after training the DGL, followed by testing the DGL model on 640 unseen datasets (Figure 5.50). The accuracy of the model exceeded 98%. In the 640 datasets,

Chapter 5: Machine Learning Models to Cluster and Classify Building and Ground Relationship

the model correctly predicts 627 cases in the right category, while only 13 cases fall into the incorrect category.

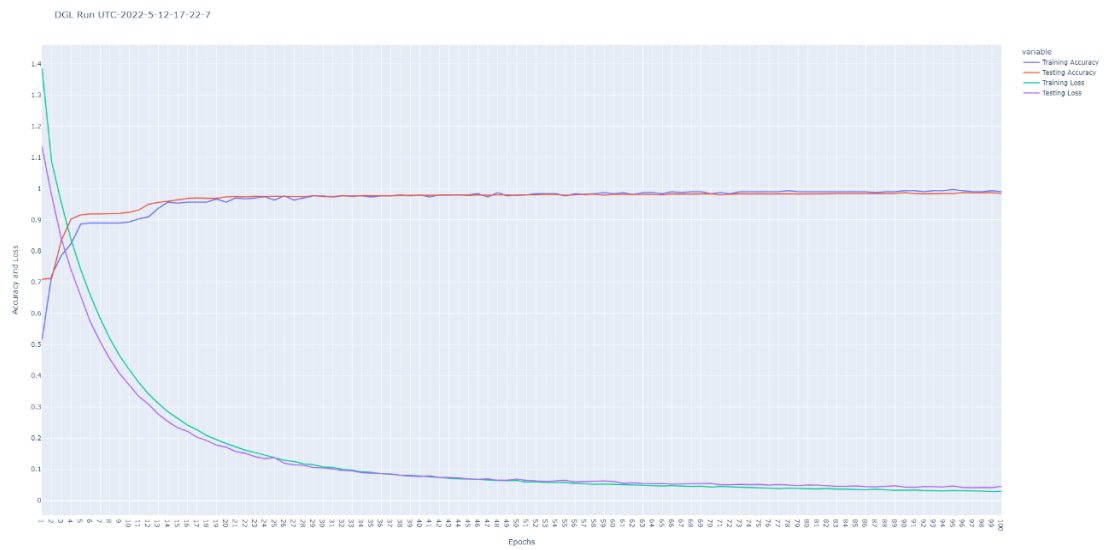

Figure 5.48: DGL performance plots, average accuracy, and average loss

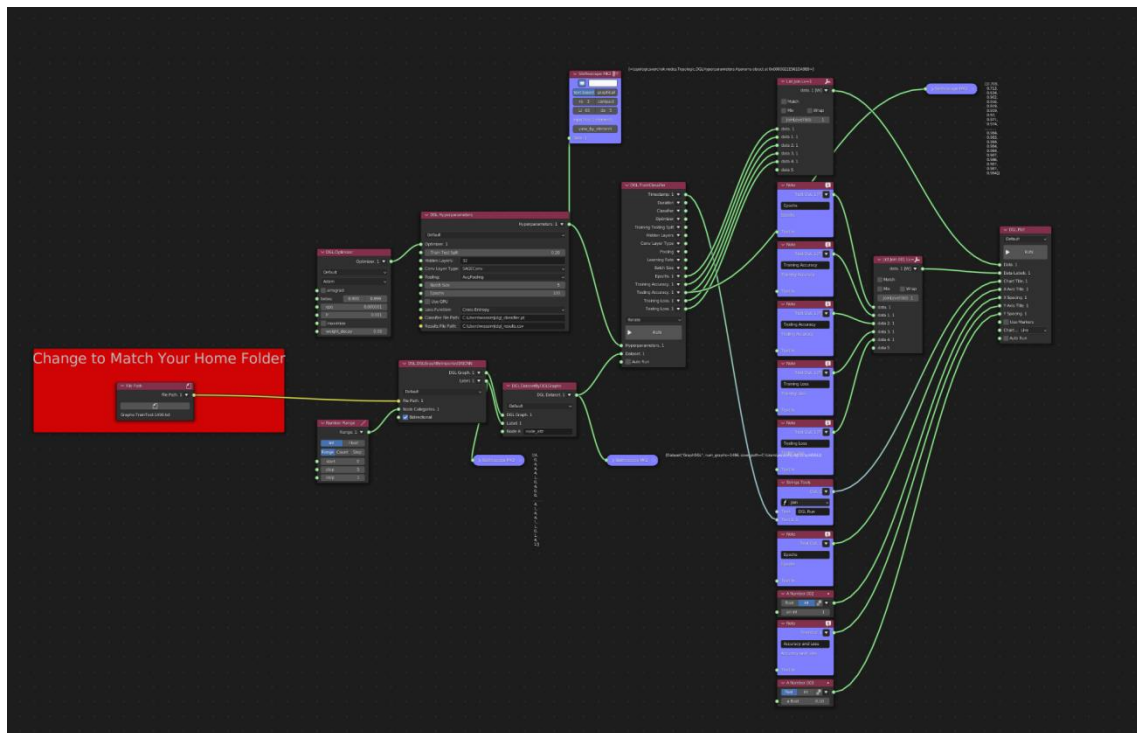

Figure 5.49: The DGL Workflow in Blender (Training the DGL)

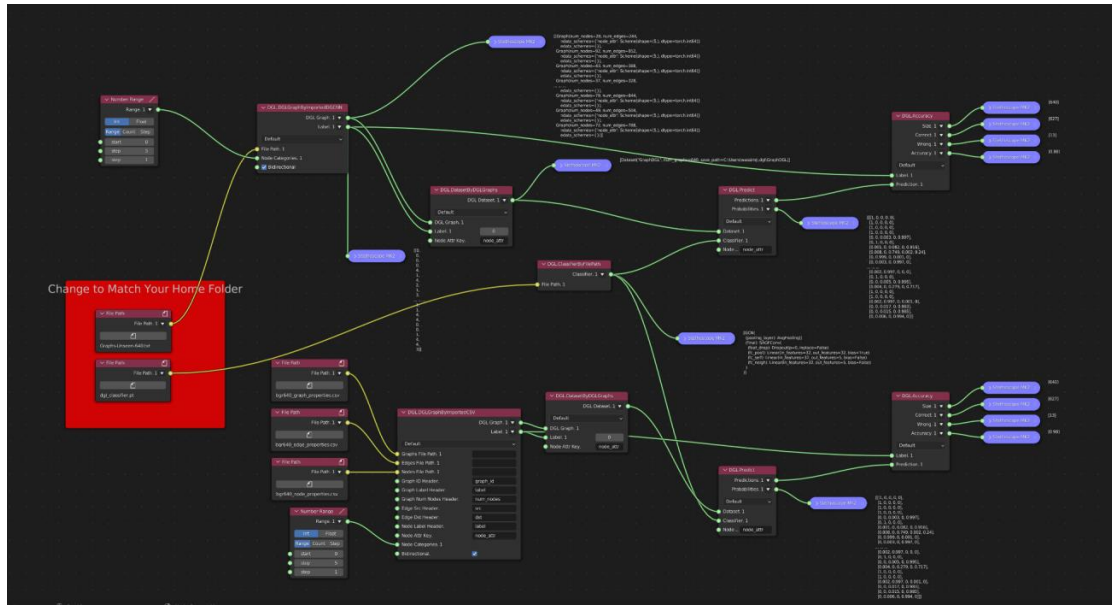

Figure 5.50: The DGL Workflow in Blender (Prediction using the saved DGL)

5.3.8. Unsupervised Graph-Level Representation Learning (UGLRL) Experimental Results

This section applies a different ML algorithm. However, this time it is an unsupervised learning algorithm. This approach started by classifying the task and then representing the whole graph in embedded space. Figure 5.51 clarifies the representations of the topological graph within the 3D environment and within the ML software. While the nodes in the original dual graph (Figure 5.51, left) are placed at the centre of the model elements within 3D space, the topological graph (Figure 5.51, middle) and its textual representation (Figure 5.51, right) are geometry independent. Thus, the XYZ coordinates of the original dual graph nodes are not required.

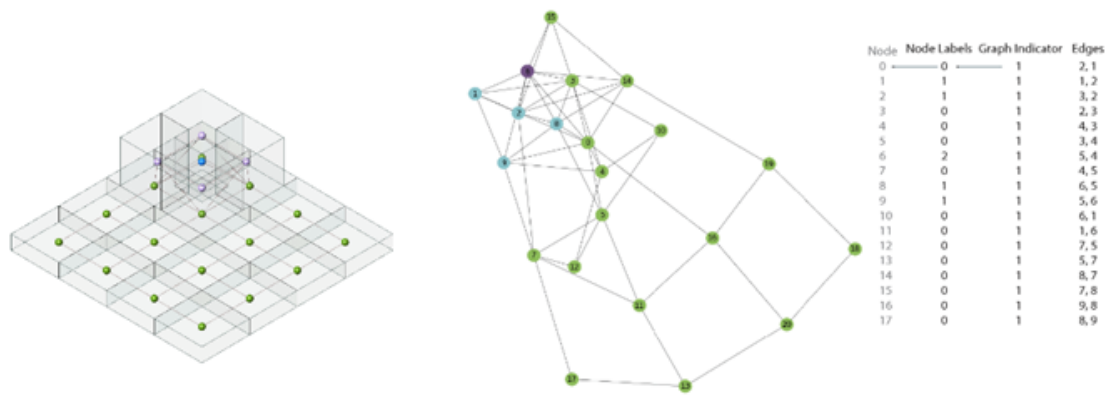

Figure 5.51: Graph 1 from data. Visualised with matplotlib. The table shows how an adjacency matrix, node labels and graph indicators work within the text files

5.3.8.1. Date Conversion

The code for InfoGraph ⁽²¹⁾ was created to run using the TUDataset module from Pytorch Geometric. Therefore, the input data required conversion into the same format as all the TUDatasets. The original data containing all 2,136 graphs were created to work with the format from the DGCNN. Using the dataset MUTAG as an example, a code generated an adjacency matrix for all 2,136 graphs (Figure 5.52).

To convert the data, the researcher prepared the following three text files as input to (InfoGraph), which is the used unsupervised graph representation learning model.

1. DS_A.txt: Adjacency matrix for all graphs, in which each line corresponds to (row, columns) for (node_id, node_id).
2. DS_graph_indicator: The column vector of graph identifiers for all nodes of all graphs, the value in the i-th line is the graph_id of the node with node_id i.
3. DS_node_labels: The column vector of node labels, the value in the i-th line corresponds to the node with node_id i.

It is crucial to mention that the data that worked with InfoGraph comprised undirected graphs, so all the edges were bidirectional. Additionally, the nodes needed to be in a continuous list, starting from 1 to 120,160 (the number of nodes in the dataset).

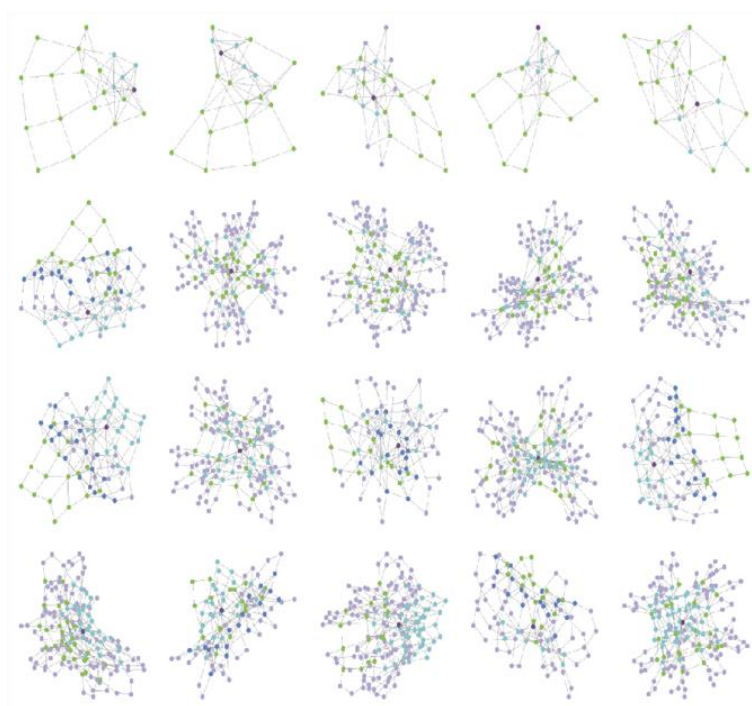

Figure 5.52: First 25 graphs of the data were created and visualized using network X and matplotlib.

⁽²¹⁾ <https://github.com/fanyun-sun/InfoGraph>

5.3.8.2. Optimisation of the Unsupervised Graph-Level Representation Learning (UGLRL)

The experiment maintained the default Graph Isomorphism Network (GIN) model (Sun et al. 2020). The experiment results are shown below, and according to Sun *et al.* (2020), the researcher varied the following hyperparameters: learning rate, number of epochs and batch size. To visualise the graph, a t-SNE plot embedded the whole graph into a 2D space for graph visualisation, where each graph becomes a point. Providing human insights into the dataset facilitates further analysis of the data. The code was run in CPU mode in a Dell XPS Intel Core i7 with 16 GB RAM.

5.3.8.2.1. Learning Rate

Variations in the model's learning rate may affect its performance. The results of four different learning rates (1e-5, 1e-4, 1e-3 and 1e-2) have been documented (Table 5.16). The test had initially involved a fixed batch size of 128 and epochs set to 20. All four runs achieved high representation learning accuracy when used in the downstream classification task. A learning rate of 1e-4 achieved the highest prediction accuracy (99.3%) (Table 5.16). The t-SNE plot for the last epoch of each run underwent examination to determine the learning rate for the next experiment. Each t-SNE plot displays a clear distributed representation of the graphs in each group (Figure 5.53). Thus, the best accuracy (99.3%) with a learning rate of 1e-4 was selected as the baseline for further evaluation of other hyperparameters.

Table 5.16: Accuracy results using various learning rates

Learning rate	Mutual information loss (MI)	Accuracies			
		logreg	Svc	Linear svc	Random forest
1e-5	2196.70	0.983	0.991	0.990	0.989
1e-4*	205.20	0.981	0.993	0.993	0.988
1e-3	23.20	0.983	0.987	0.993	0.977
1e-2	28.58	0.984	0.993	0.988	0.987

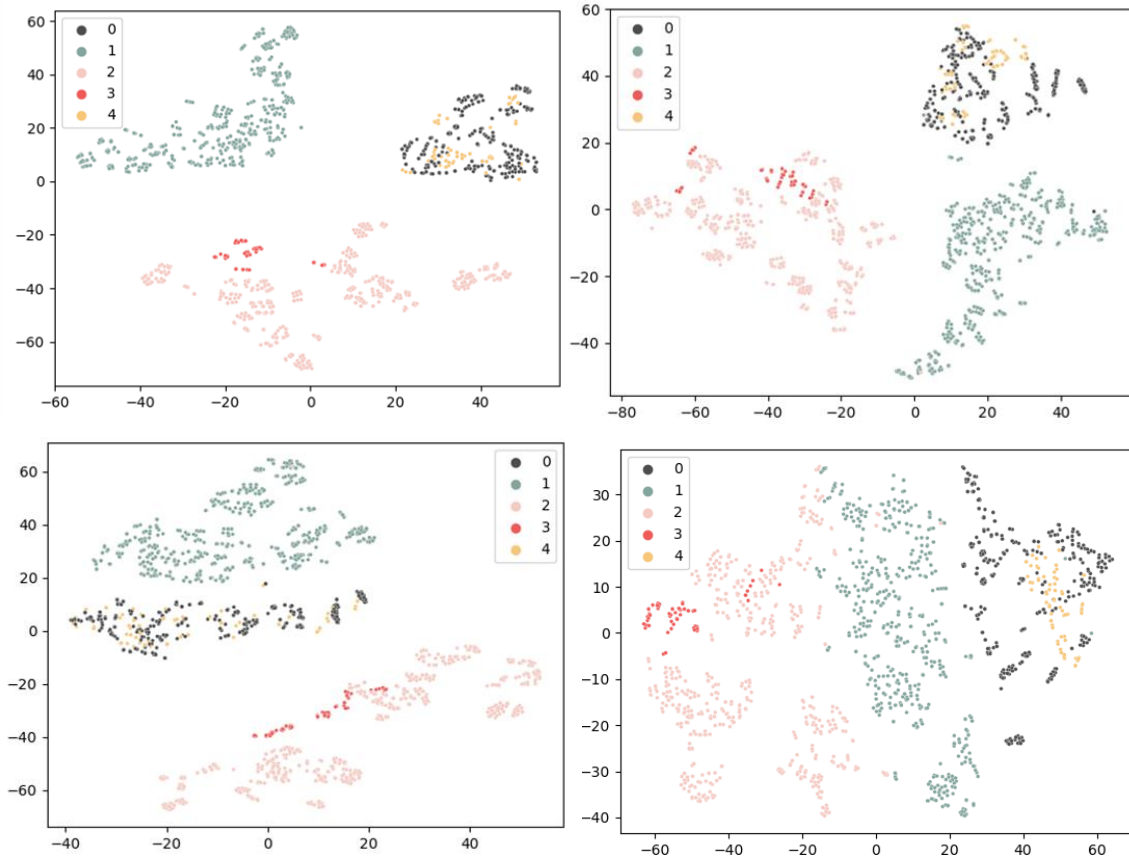

Figure 5.53: t-SNE plot for, 1e-5(top-left),1e-4(top-right),1e-3(below-left) and 1e-2(below-right)

5.3.8.2.2. Number of Epochs

It remains crucial to optimise the number of epochs since too low or too high a value can lead to underfitting or overfitting, respectively. The experiment involved numerous epochs while maintaining a testing rate of 1e-4 (Table 5.17). All 10, 20 and 50 epochs of the representation learning model produced highly accurate accuracy results. However, across the different accuracy performance levels, the 20 epochs show the most consistent accuracy. To determine the distribution of each graph, the researcher used the t-SNE plot. Even though all runs perform well, based on the t-SNE plot (Figure 5.54), we chose to run with 20 epochs to continue testing other hyperparameters in subsequent experiments.

Table 5.17: Accuracy results using various numbers of epochs

Number of epochs	Mutual information loss (MI)	Accuracies			
		logreg	Svc	Linear svc	Random forest
10	385.92	0.981	0.992	0.989	0.985
20	205.20	0.981	0.993	0.993	0.988
50	39.80	0.985	0.993	0.995	0.973

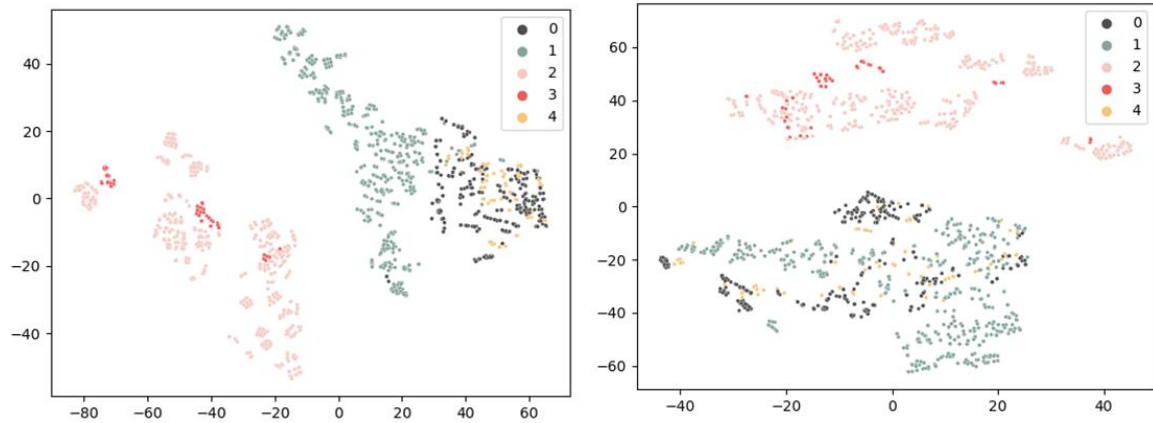

Figure 5.54: t-SNE plot for 10 epochs (left) and 50 epochs (right)

5.3.8.2.3. Batch Size

The last hyperparameter experiment involved a learning rate of 1e-4 and 20 epochs. The experiment featured three different batch sizes of 32, 64 and 128 (Table 5.18). To determine the best-distributed representation for each graph, the t-SNE plot underwent examination (Figure 5.55). Additionally, the total processing/run time requires documentation to determine how the batch size affects the time taken. In the 32 and 64 batch size cases, the total time was negligible. However, it became time-consuming and costly in the case of 128 batch sizes.

Table 5.18: Accuracy results using various batch sizes

Batch sizes	Accuracies				Total processing time
	logreg	Svc	Linear svc	Random forest	
32*	0.981	0.993	0.993	0.988	1.20 hours
64	0.994	0.994	0.986	0.988	2.12 hours
128	0.987	0.989	0.994	0.975	24.89 hours

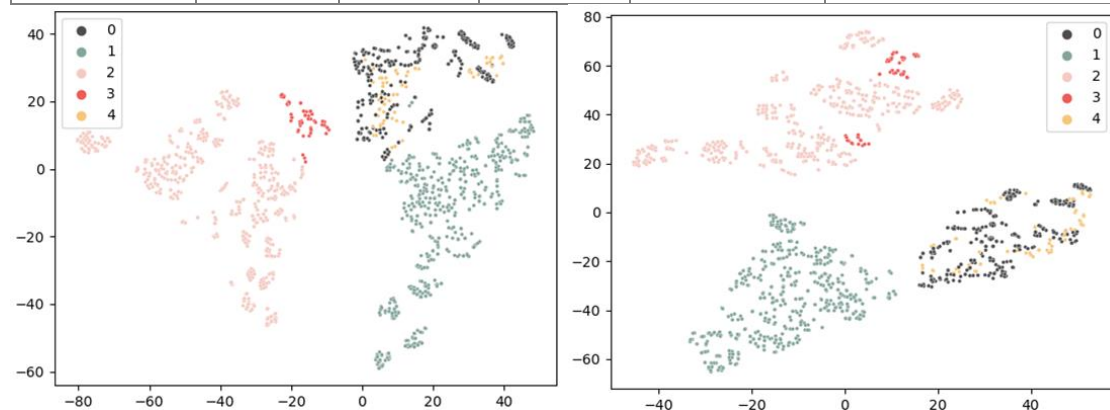

Figure 5.55: t-SNE plot for 64 batch sizes (left) and 128 batch sizes (right)

5.4. Chapter Summary

Through the clustering of architects' styles based on their approach to the relationship between building and ground, it is possible to categorize an extensive database into semantic groups associated with specific historical periods, building types, and regions. With the help of these database groups, data can be retrieved quickly and efficiently. An examination of the most widely used unsupervised learning algorithms, K-Means, K-Modes, and Gaussian Mixture Models, is presented. Although all the unsupervised learning algorithms used achieved high accuracy, experiments involving the K-means clustering algorithm showed a higher and constant level of accuracy than experiments using other clustering algorithms.

Based on the results of the experiment (Table 5.19), it can be concluded that all datasets, both residential and public precedents, were able to achieve 84.5% accuracy using 5 clusters (K). Further, the residential precedents demonstrate a similar performance (84.5%) at the same number of clusters, which is 5 (K). Further, public precedents demonstrate a marginally higher performance (85%) when compared to the same number of clusters (K). Thus, researchers will be able to create a taxonomy of architectural precedents based on the similarity between them.

Table 5.19: Best K-means experiments for the different dataset

Clustering Methods K-means	All dataset (Residential and Public)		Residential dataset		Public dataset	
	silhouette score	% Accuracy	silhouette score	% Accuracy	silhouette score	% Accuracy
Number of K						
5	0.69	84.5%	0.69	84.5%	0.70	85%

In the second part of this chapter, the researcher implemented a variety of algorithms to achieve the goal of classifying architectural topology through a novel workflow that utilizes ML on 3D graphs rather than 2D images. One of the first algorithms implemented was DGCNN. During the experiment, it was demonstrated that the DGCNN was able to accurately predict and classify the building and ground relationship into five separate classes with a high degree of accuracy. The best model parameter was determined after 23 experiments with tuning the hyperparameters. Optimal parameters of the model were as follows: two layers of convolutional layers, each layer with 32 neurons, 128 hidden layers for the final dense layer, 200 epochs, 1-e4 learning rate, and one batch size. The DGCNN model that was developed achieved 99.1% accuracy with an average loss of 0.044. As soon as the hyperparameters were tuned using the training dataset, the model that performed best was saved and tested on the

Chapter 5: Machine Learning Models to Cluster and Classify Building and Ground Relationship

test set. Afterward, the researcher utilized the unseen data, which comprised of 640 predict data points. A total of 633 examples were correctly classified, but only seven examples were incorrectly predicted, demonstrating a 98.9% accuracy rate.

To validate the results and the workflow further, the researcher used DGL algorithms. In both training and prediction, DGL achieved high accuracy results. According to the results of DGL, the accuracy performance reached 98.4% with an error loss of 0.1. The best structure performance was achieved using 32 hidden layers, Adam optimizer, SAGEConv layer, 80-20% split between training and testing, MaxPooling layer, Loss function, and Number of epochs is 100, Batch size is 5, and the learning rate is 0.001. The same as DGCNN the best DGL model was saved. Following this, 640 unseen datasets were used to test the DGL model. Approximately 98% of the model was accurate. Among the 640 datasets, the model correctly predicted 627 cases in the right category, while only 13 cases fell into the wrong category.

Finally, the researcher implemented Unsupervised Graph-Level Representation Learning (UGLRL). Unsupervised learning focuses on unlabelled data and generates a representation, which can aid future downstream tasks, such as classification. The approach is promising for the recognition of architectural forms based on semantically relevant and structured data. According to the results of the experiments, all four different accuracy measures, Logreg, SVC, Linear SVC, and Random Forest, achieved high representation learning with more than 98% accuracy.

CHAPTER SIX

COMPUTATIONAL TOOL TO RETRIEVING SIMILAR BUILDING AND GROUND RELATIONSHIP PRECEDENTS (BGR TOOL)

Part (A): Interface of Building and Ground Relationship Precedents (BGR Tool)

Part (B): Evaluate the (BGR Tool) Using System Usability Scale (SUS)

Chapter 6: Computational Tool to Retrieving Similar Building and Ground Relationship Precedents (BGR Tool)

6.1. Chapter Overview

At the end of the process, designing a computational tool will require an interface or workflow guideline that is easy to use for the architect user. Moreover, a test involves using the tool to generate different solutions and then verifying the results to ensure the model is reliable and effective, as well as its ability to fulfil the actual purpose for which it was developed. An evaluation of the usability of a tool consists of examining its clarity, functionality, accessibility, and flexibility (Carley 1996).

Chapter six includes two parts. The first part, (Part A: Interface of Building and Ground Relationship Precedents (BGR Tool)), presents the BGR interface tool. The workflow (interface) is intended to assist architects during the early stages of design in making informed decisions. This research part seeks to develop a guideline for the BGR software tool.

After a computational tool has been developed, usability testing and evaluation should be performed. The second part, (Part B: Evaluate the (BGR Tool) Using System Usability Scale (SUS)), examines and evaluates the developed computational tool for retrieving similar architectural precedents of BGR. Two parts are involved in this process. Firstly, a mix of architects and third-year architecture students were asked to produce concepts for conceptual designs, and then the proposed BGR tool was used to test the results by classifying and retrieving similar architectural precedents. The second part, a usability evaluation, is intended to determine the effectiveness of the tool at an early stage of design through the distribution of a (SUS) questionnaire to the participants.

Part (A) Interface of Building and Ground Relationship Precedents (BGR Tool)

6.2. Develop Building and Ground Relationship (BGR) Tool

To assist architects in making informed decisions during the early stages of design, this research seeks to develop a software tool. The developed workflow tool consists of three main stages: create, implement, and retrieve (Figure 6.1).

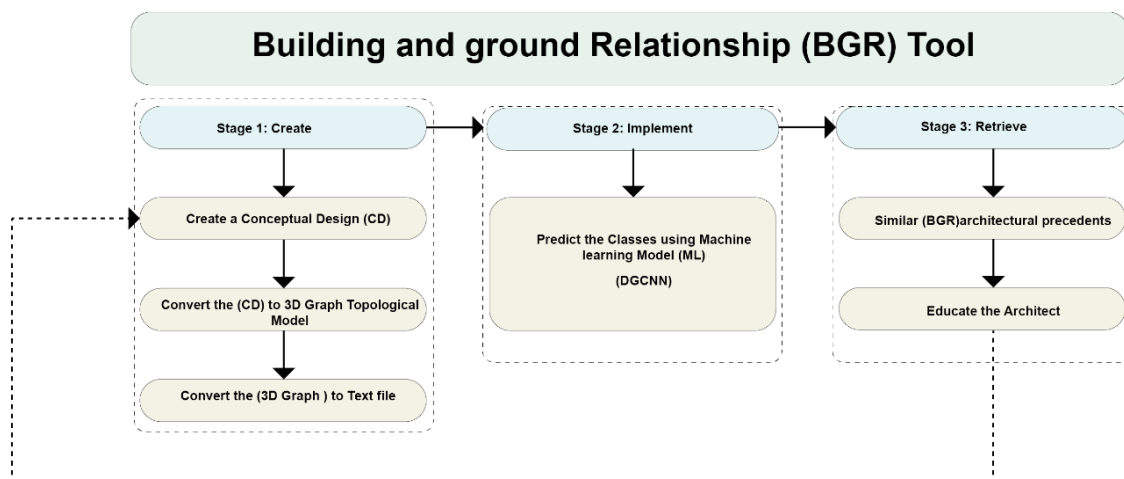

Figure 6.1: The Workflow of the BGR Tool

Stage 1: **Creating** the building ground relationship object. In this stage, the architects will develop a 3D design with simple geometry and then convert it into its dual 3D topological graph. Rhinoceros, Grasshopper, and Topologic software applications will be utilised to design and produce the graph. Afterwards, the graph will be converted to text (Figure 6.2).

Stage 2: **Implement** the saved DGCNN machine learning model to predict the 3D graph of the produced conceptual design. The 3D graph will be classified into 5 different classes, which are separation, separation with plinth, adherence, adherence with plinth, and interlock (Figure 6.2).

Stage 3: **Retrieve** similar architecture precedents - With the datasets collected and archived, the architects could obtain not only images of architectural precedents but could also retrieve the name of the architect, building type, building status, building location, and building period (Figure 6.2).

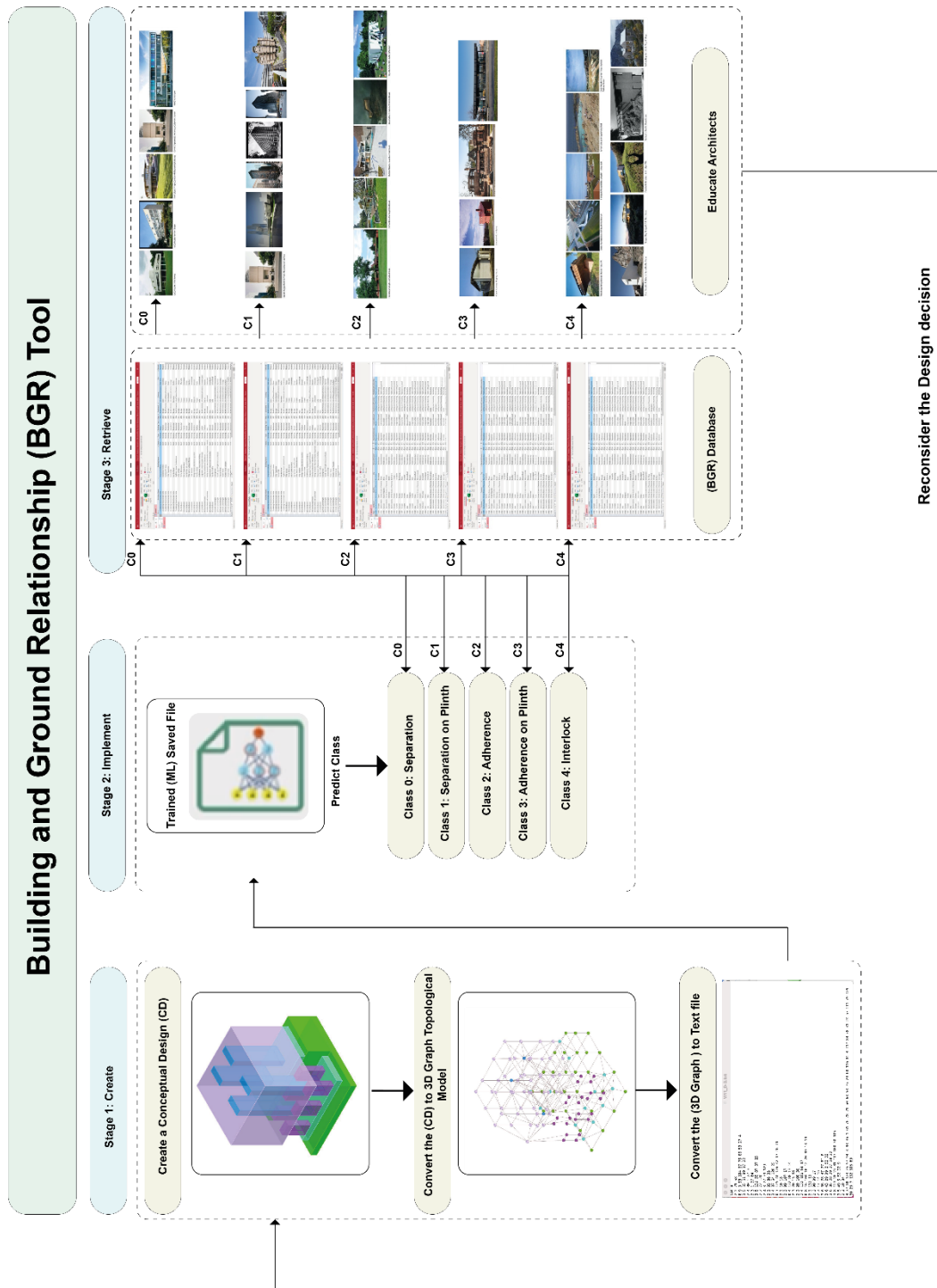

Figure 6.2: Detailed Workflow of the created BGR tool

Part (B) Evaluate the (BGR Tool) Using System Usability Scale (SUS)

6.3. Usability Evaluation for the Developed Computational Tool: An Experimental Study

The concept of usability cannot be defined in an absolute sense; it must be viewed in the context of a given situation. Although this is the case, a general measure of usability needs to be employed to compare usability across a range of contexts (Brooke, 1995). Furthermore, there is a need for low-cost methods for evaluating the usability of industrial systems quickly. System Usability Scale (SUS) is a reliable, low-cost method of assessing the ease of use of systems that can be used for global assessments (Brooke 1995; Brooke 2013).

The usability of any tool depends on its clarity of application (Kitchley and Srivathsan 2014). It could be measured by three aspects: (a) effectiveness: how well the tool achieves its objectives; (b) efficiency: time and effort that have been expended to achieve the objectives; and (c) satisfaction: the acceptability of the tool by users (Park and Hwan Lim 1999). Consequently, an experimental study has been conducted to determine how well the developed tool addresses these aspects.

The study asked professionals, and 3rd-year architecture students, to use the tool for the design of a multi-story residential building. The target was to assess the flexibility and creativity of the tool in the early stage of the design and to compare the results of users who were not experienced with the interface with results produced by the researcher.

6.3.1. Criteria for the Evaluation Process

A user-based assessment can be used to determine if a computational tool is effective, efficient, and satisfactory. This evaluation could be carried out empirically through the testing of the tool with real users to evaluate its usability (Nielsen 1994). An acceptable user interface should meet a set of usability criteria (Jeffries et al. 1991; Park and Hwan Lim 1999; Paryudi and Fenz 2013): Suitability for the task, controllability by the user, adaptability, robustness (in preventing and correcting errors), compatibility (with users' expectations), self-explain ability, and consistency (in location, format, syntax, and naming).

6.3.2. The Questionnaire Design

According to the aforementioned criteria, a questionnaire was designed to evaluate the developed tool. A total of 34 questions were categorised into four sections. As part of the survey, participants were asked to rate the following issues on a five-point scale ranging from

Chapter 6: Computational Tool to Retrieving Similar Building and Ground Relationship Precedents (BGR Tool)

(1) to (5), where (1) indicates a strong disagreement, and (5) indicates strong agreement. Participants were asked to add comments after each section of the questionnaire. These comments will suggest a list of issues that need to be considered to enhance the interface and positive aspects of the tool.

Section One: Four questions to evaluate participants' familiarity with the used tools. (*Extremely familiar - Very familiar- Familiar- Somewhat familiar- Not familiar*).

1. How familiar are you with Visual Dataflow Programming tools?
2. How familiar are you with Grasshopper?
3. How familiar are you with Topologic?
4. How familiar are you with the Deep Graph Convolutional Neural Network (DGCNN)?

Section Two: A ten-item questionnaire to measure the usability of the generative building and ground workflow. (*Strongly agree -Agree -Neutral -Disagree -Strongly disagree*)

1. I think that I would like to use this workflow frequently.
2. I thought this workflow was easy to use.
3. I found the proposed workflow unnecessarily complex.
4. I think that I would need the support of a technical person to be able to use the workflow.
5. I found the various functions in the workflow well integrated.
6. I thought there was too much inconsistency in the workflow.
7. I would imagine that most people would learn to use the workflow very quickly.
8. I found the workflow very cumbersome to use.
9. I felt very confident using the workflow.
10. I needed to learn a lot of things before I could get going with the workflow.

Section Three: A ten-item questionnaire to measure the usability of the Deep Graph Neural Network system. (*Strongly agree -Agree -Neutral -Disagree -Strongly disagree*)

1. I think that I would like to use this DGCNN frequently.
2. I thought this DGCNN was easy to use.
3. I found the proposed DGCNN unnecessarily complex.
4. I think that I would need the support of a technical person to be able to use the DGCNN.
5. I found the various functions in the DGCNN well integrated.
6. I thought there was too much inconsistency in the DGCNN.
7. I would imagine that most people would learn to use the DGCNN very quickly.
8. I found the DGCNN very cumbersome to use.

Chapter 6: Computational Tool to Retrieving Similar Building and Ground Relationship Precedents (BGR Tool)

9. I felt very confident using the DGCNN.
10. I needed to learn a lot of things before I could get going with the DGCNN.

Section Four: A ten-item questionnaire to measure the whole system's usability. (*Strongly agree -Agree -Neutral -Disagree -Strongly disagree*)

1. I think that I would like to use this system frequently.
2. I thought this system was easy to use.
3. I found the proposed system unnecessarily complex.
4. I think that I would need the support of a technical person to be able to use the system.
5. I found the various functions in the system well integrated.
6. I thought there was too much inconsistency in the system.
7. I would imagine that most people would learn to use the system very quickly.
8. I found the system very cumbersome to use.
9. I felt very confident using the system.
10. I needed to learn a lot of things before I could get going with the system.

This work was carried out according to the codes of ethics applied by the investigating body as part of the research ethics. A form requesting ethical approval was submitted to the Welsh School of Architecture Ethics Committee, Cardiff University, together with the research proposal and ethics statement. On 07/04/2022, approval was obtained (SREC reference: 2216).²²

Additionally, every participant was informed about the purpose of the study, how they would participate, how long the experiment would take, and that they had the right not to answer a particular question or to withdraw from the experiment at any time. Each participant gave his or her informed consent to participate in the study.

6.3.3. Choosing a Sample of Users

As a primary goal of this experiment, the efficacy and performance of the computational tool among two groups of users: professional architects and architecture students, are compared. Despite this, participants are not expected to have any prior knowledge of Grasshopper or Machine Learning (DGCNN) to utilise the design tool.

The study included ten participants, who were either professionals or post-graduate researchers with previous experience in design in their countries, and two students who were

²² Appendix XIII: System usability scale (SUS) ethical approval forms

Chapter 6: Computational Tool to Retrieving Similar Building and Ground Relationship Precedents (BGR Tool)

in their third year of study. To maintain a reasonable time and budget for the experiment, as well as to control the execution process by the researcher, the experiment was conducted between 13.06.2022 and 20.06.2022. During each experiment, the same conditions were used, and it took approximately 45 minutes to complete each experiment (Table 1). Before each experiment, the researcher provided a brief tutorial. Moreover, the participants were introduced to the rules and Grasshopper through a detailed description. Users completed an evaluation form regarding the tool at the end of the implementation.

Table 6.1: Sample of users who participated in the experimental study

Number	Background and professional experience			
	3 rd Year architecture student	Architect	Years of experience	Country (Where the architect practised the profession or studied)
Participant # 1		x	8 years	USA/ Switzerland
Participant # 2		x	6 years	Singapore
Participant # 3		x	11 years	USA/UK/ Saudi Arabia
Participant # 4	x		-	UK
Participant # 5		x	16 years	USA/UK/ Saudi Arabia
Participant # 6		x	11 years	Libya/UK
Participant # 7		x	10 years	USA/Saudi Arabia
Participant # 8	x		-	UK
Participant # 9		x	3 years	USA/Saudi Arabia
Participant # 10		x	10 years	USA/UK/ Saudi Arabia
Participant # 11		x	6 years	Saudi Arabia
Participant # 12		x	12 years	USA/Saudi Arabia

6.3.4. Solutions Produced by Participants

Participants were asked to design a building that met the following requirements:

- An individual had the option to choose between flat ground, sloped ground, or stepped ground.
- The number of building objects is not limited; neither is the number of cores.
- The height and number of floors are not restricted.
- If the participant intends to design the relationship as separation with plinth or adherence with plinth, plinths and columns are required.

The relationship was created by all participants in accordance with the rules that were explained to them. A variety of solutions was produced. Two participants designed the building as a separation on a plinth, while three participants designed the concept as separation. Three participants used the adherence approach as a method of ensuring the ground meets the building, while one used the adherence with plinth method. The interlocking design solution was, however, preferred by three architects. In total, 1275 nodes

Chapter 6: Computational Tool to Retrieving Similar Building and Ground Relationship Precedents (BGR Tool)

were produced from 12 graphs by the participants. All the predicted classes were correct according to DGCNN saved models. The total number of retrieved cases from the dataset was 1651 cases (Table 6.2).

Table 6.2: All the Solutions produced by participants

Participant Number	Solutions Produced by Participants				
	Building/ ground relationship	Number of Nodes	The predicted class accuracy	The predicted class (True /False)	Number of retrieved cases
Participant # 1	Separation	84	100%	True	156
Participant # 2	Separation with plinth	58	100%	True	7
Participant # 3	Adherence with plinth	94	100%	True	52
Participant # 4	Interlock	118	99.9%	True	177
Participant # 5	Separation	165	11%	True	165
	Adherence		89%	True	115
Participant # 6	Interlock	73	99.9%	True	177
Participant # 7	Separation	190	100%	True	156
Participant # 8	Separation with plinth	111	100%	True	7
Participant # 9	Interlock	78	99.9%	True	177
Participant # 10	Adherence	113	98.9%	True	115
	Interlock		1.1%	True	177
Participant # 11	Separation	112	100%	True	156
Participant # 12	Adherence	79	100%	True	14
Total		1275		12	1651

As compared to other applications, the tool allowed architects and students to complete the design in a shorter period (Figure 6.3). This is because they are required to follow a structured process, along with predefined parameters that control the process of generation. An average third-year student can usually complete the design, classification, and retrieval of architectural cases for a building and ground relationship using the BGR tool within 30 minutes, while completing a sketch manually or using other software will take them between 2 and 3 hours. According to the results of the 12 participants, 50% of the participants finished the task in around 25 minutes; however, only 8% of the participants finished the task in around 35 minutes. All participants took an average of 28 minutes to complete the task.

Chapter 6: Computational Tool to Retrieving Similar Building and Ground Relationship Precedents (BGR Tool)

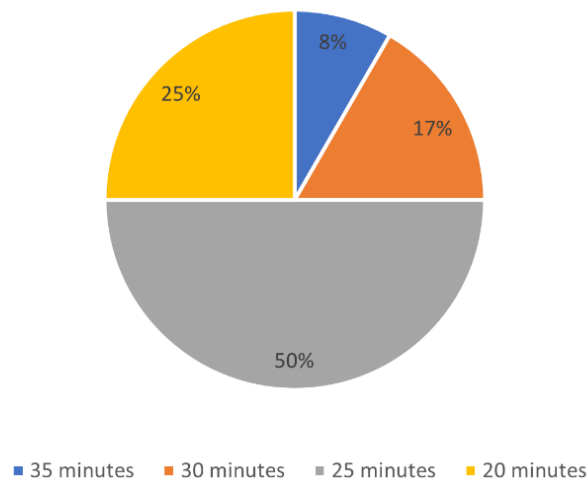

Figure 6.3: Amount of time for completing the design using BGR tool

According to most users (92% of the sample), performing tasks was not difficult to learn. Nearly 58.3% of participants stated that the tutorials and information provided during each stage were clear and effective, and thus there were no questions regarding the process (Figure 6.4). Regarding the grasshopper commands, 25% of the participants had clear understanding of the used commands. However, 33.3%, 33.3%, and 8.33% of participants asked one, two, or three questions, respectively, regarding commands. They were primarily concerned with how to use commands in Grasshopper and how to run the DGCNN in Python. Such comments can be useful for improving the representation of the interface.

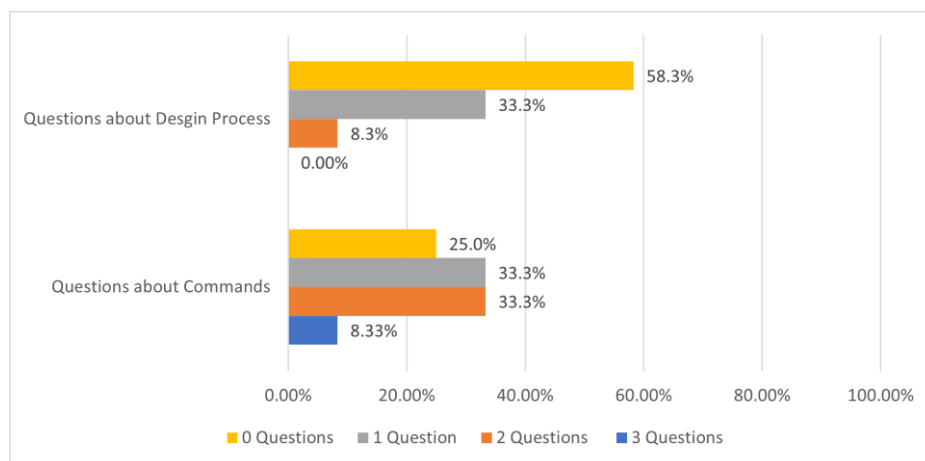

Figure 6.4: Number of questions from participants regarding commands and design processes

As a result of the implementation, only 33.3% of users encountered errors when producing the graph from the designed geometry (Figure 6.5), but these errors were easily corrected. Most architects (66.7%) were able to design, predict and retrieve similar cases without any errors. This demonstrated the effectiveness of the BGR Tool.

Chapter 6: Computational Tool to Retrieving Similar Building and Ground Relationship Precedents (BGR Tool)

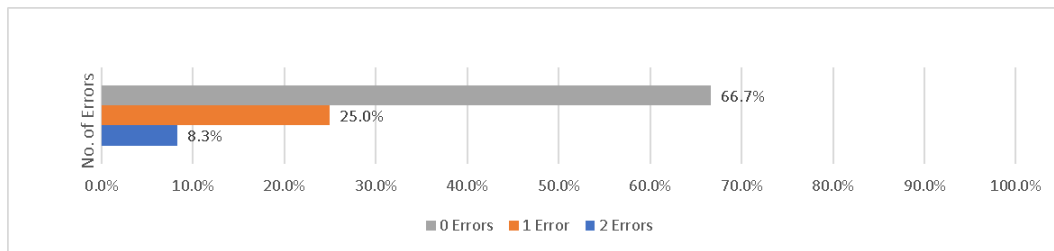

Figure 6.5: Number of errors faced the users during implementation process

The researcher provided all participants with a demonstration of the BGR interface tool. The tool interface is divided into three sections: design, prediction, and retrieval. (Figure 6.6). The following is a list of all the solutions produced by the participants, starting with participants 1 to 12 (Figure 6.7 to Figure 6.18).

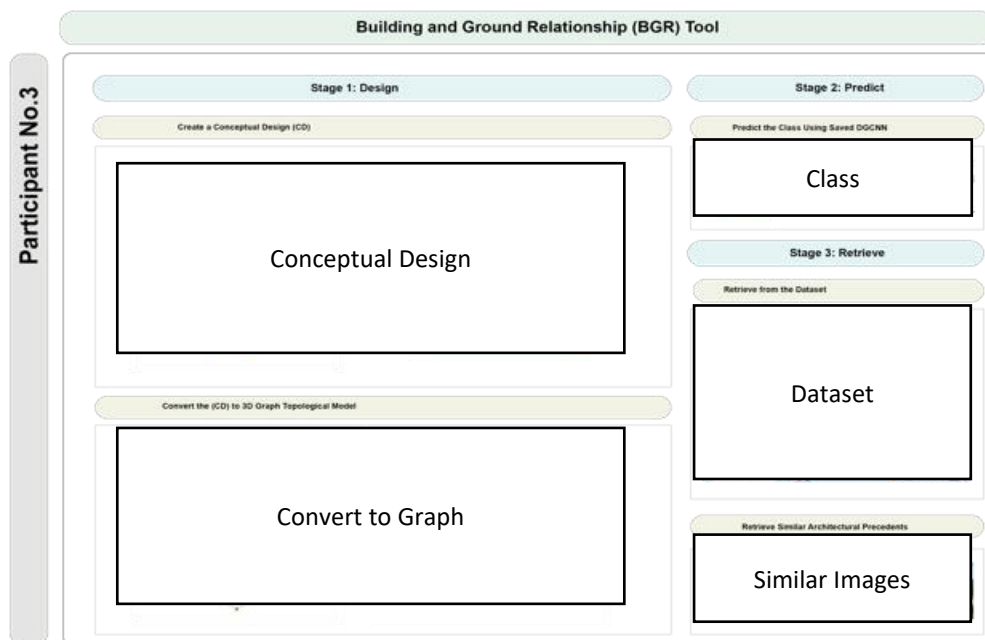

Figure 6.6: An example of the initial interface provided to participants

Chapter 6: Computational Tool to Retrieving Similar Building and Ground Relationship Precedents (BGR Tool)

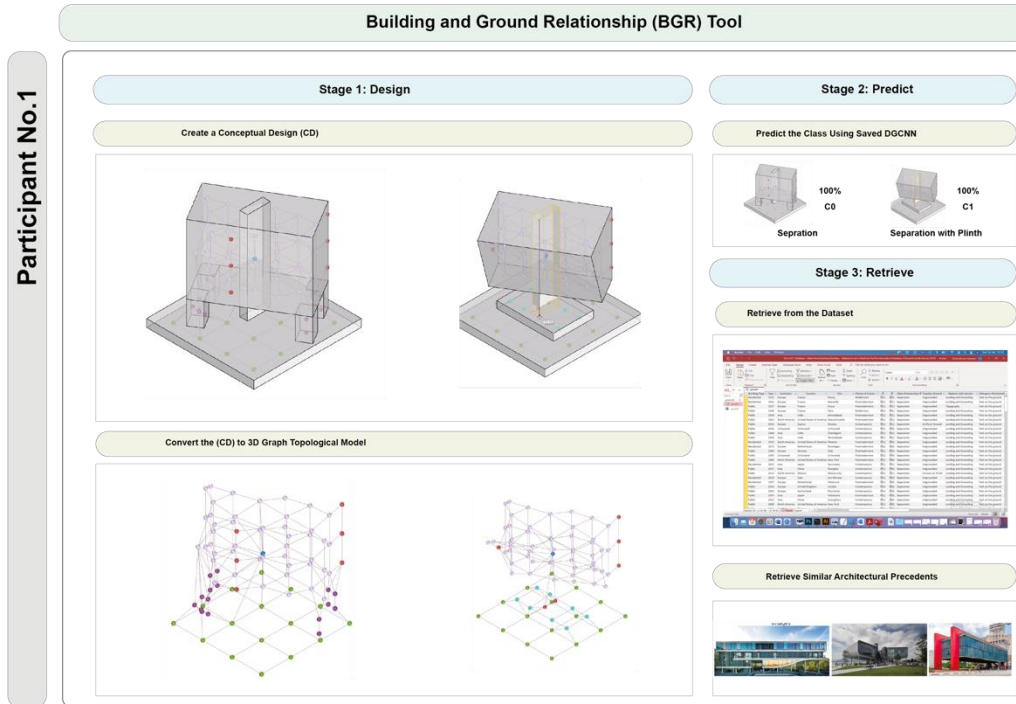

Figure 6.7: Solution produced by participant 1

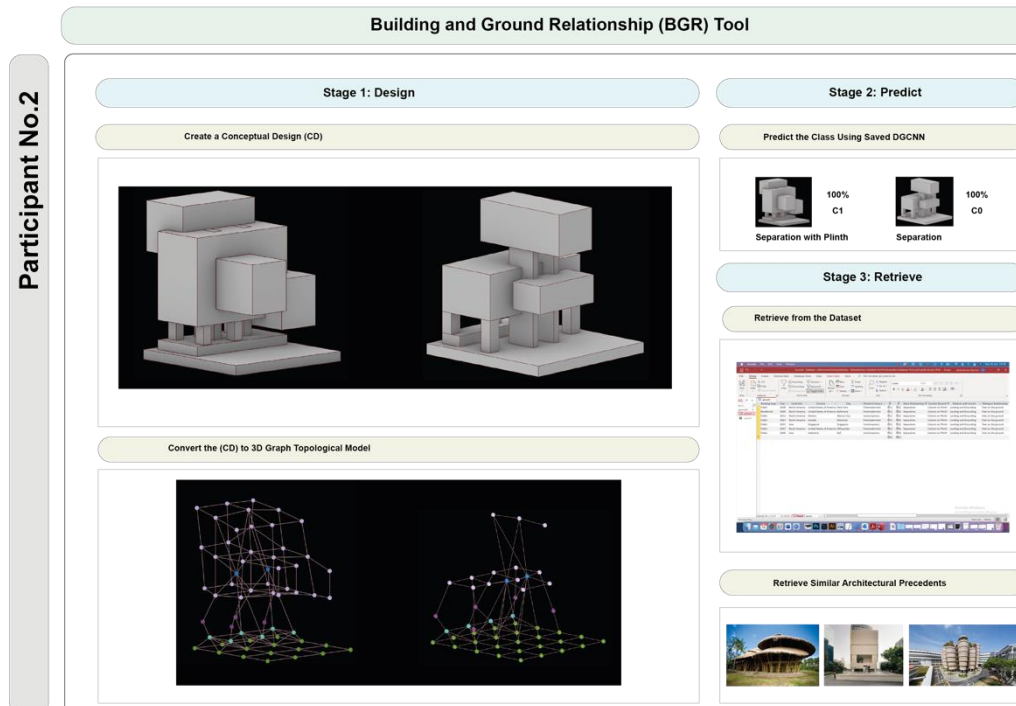

Figure 6.8: Solution produced by participant 2

Chapter 6: Computational Tool to Retrieving Similar Building and Ground Relationship Precedents (BGR Tool)

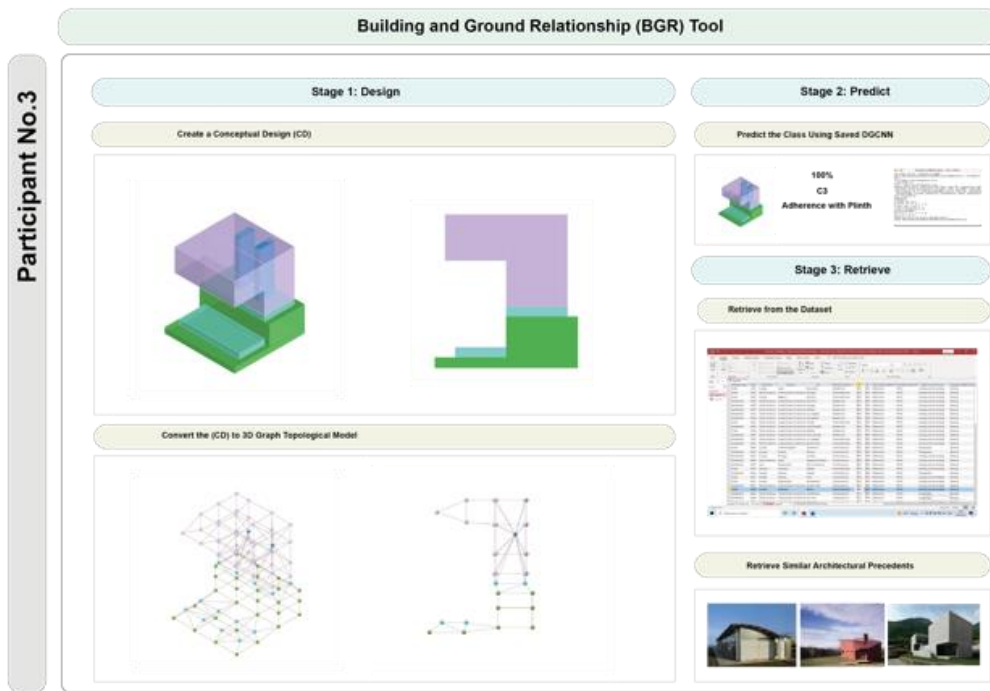

Figure 6.9: Solution produced by participant 3

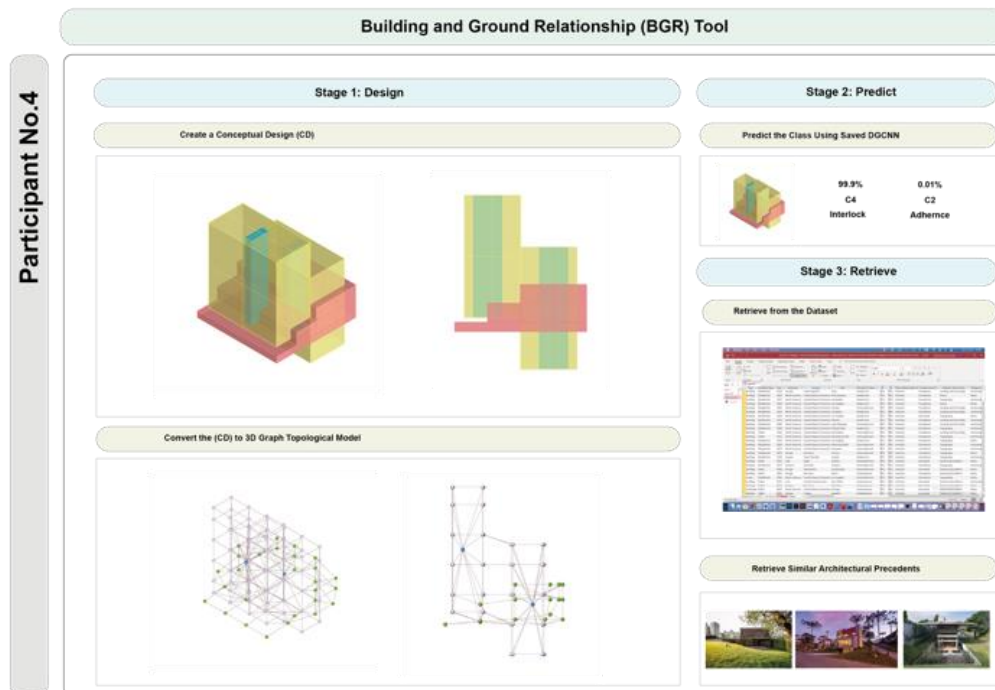

Figure 6.10: Solution produced by participant 4

Chapter 6: Computational Tool to Retrieving Similar Building and Ground Relationship Precedents (BGR Tool)

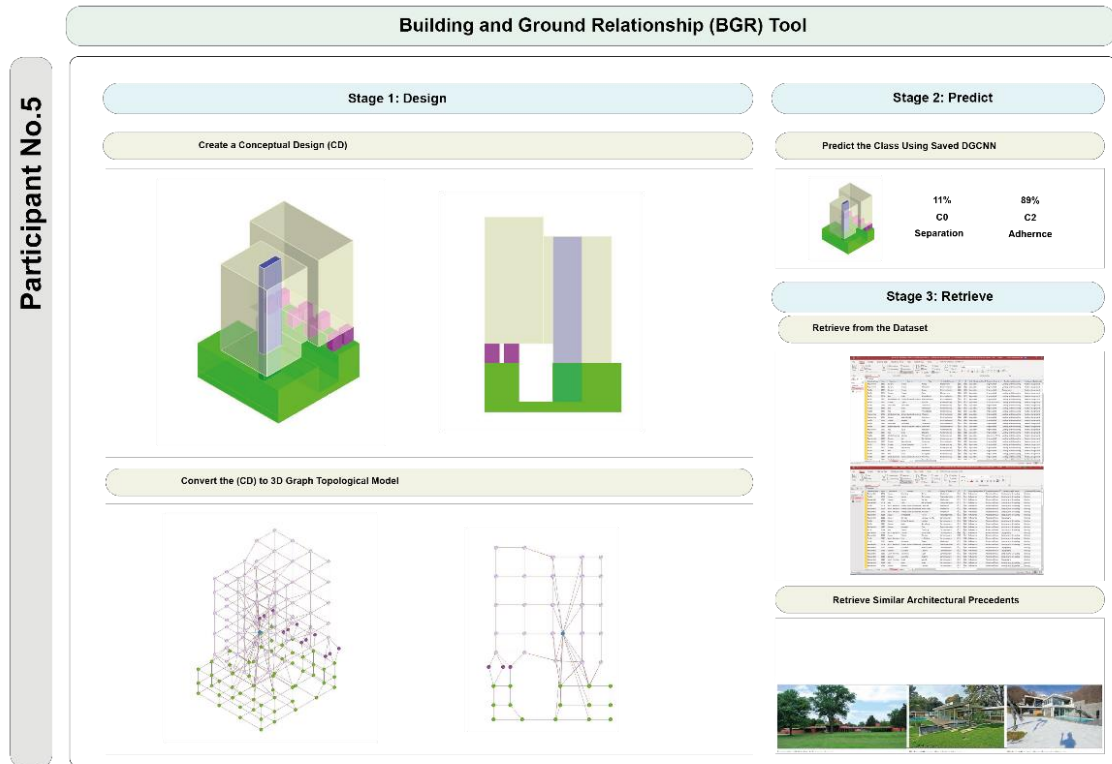

Figure 6.11: Solution produced by participant 5

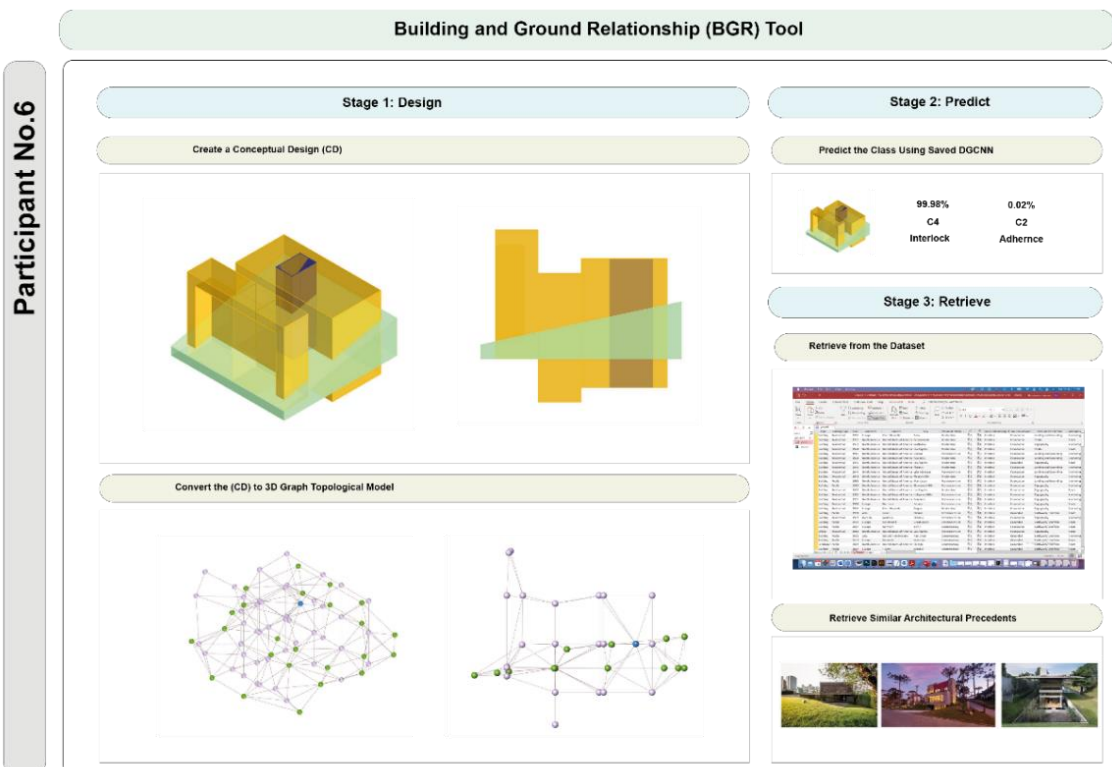

Figure 6.12: Solution produced by participant 6

Chapter 6: Computational Tool to Retrieving Similar Building and Ground Relationship Precedents (BGR Tool)

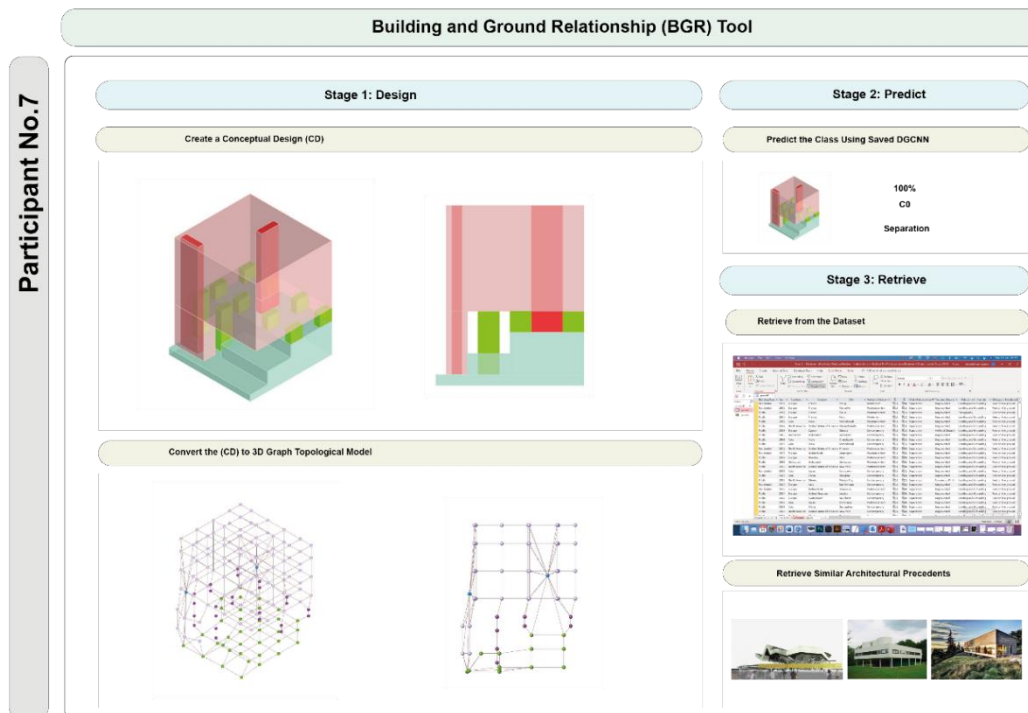

Figure 6.13: Solution produced by participant 7

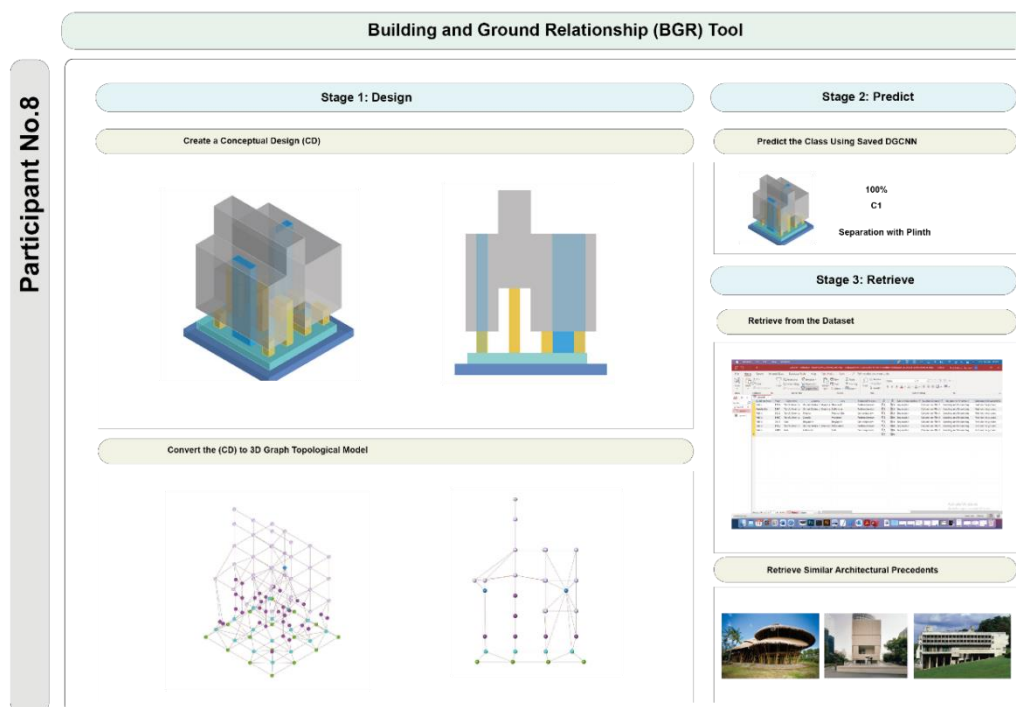

Figure 6.14: Solution produced by participant 8

Chapter 6: Computational Tool to Retrieving Similar Building and Ground Relationship Precedents (BGR Tool)

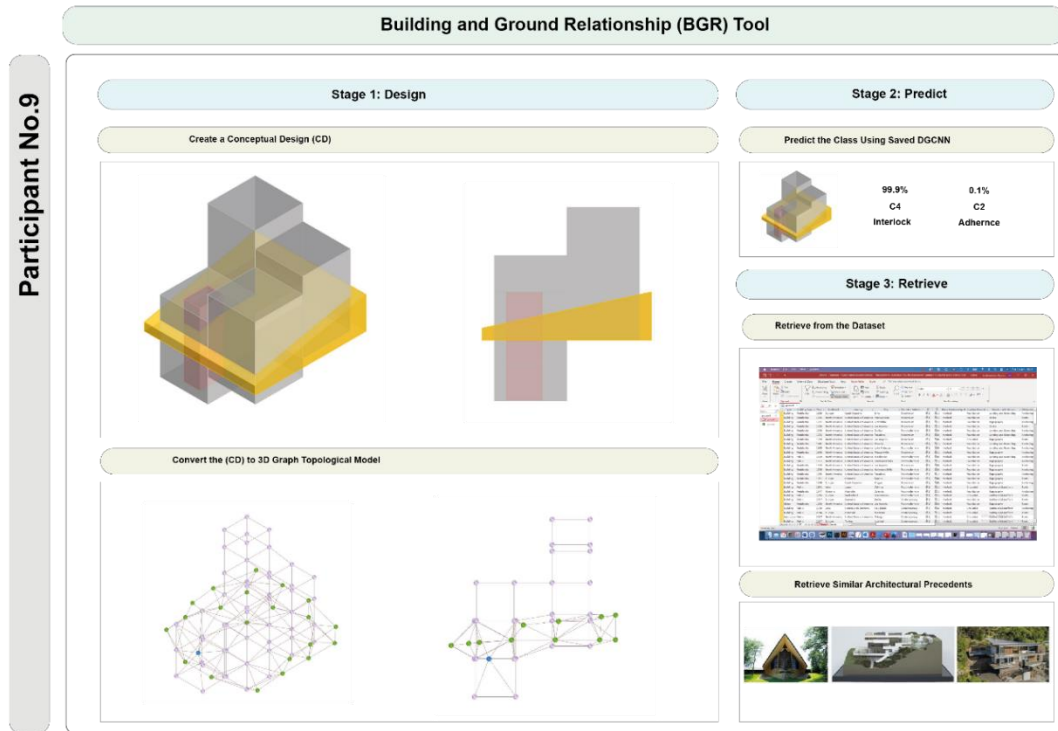

Figure 6.15: Solutions produced by participant 9

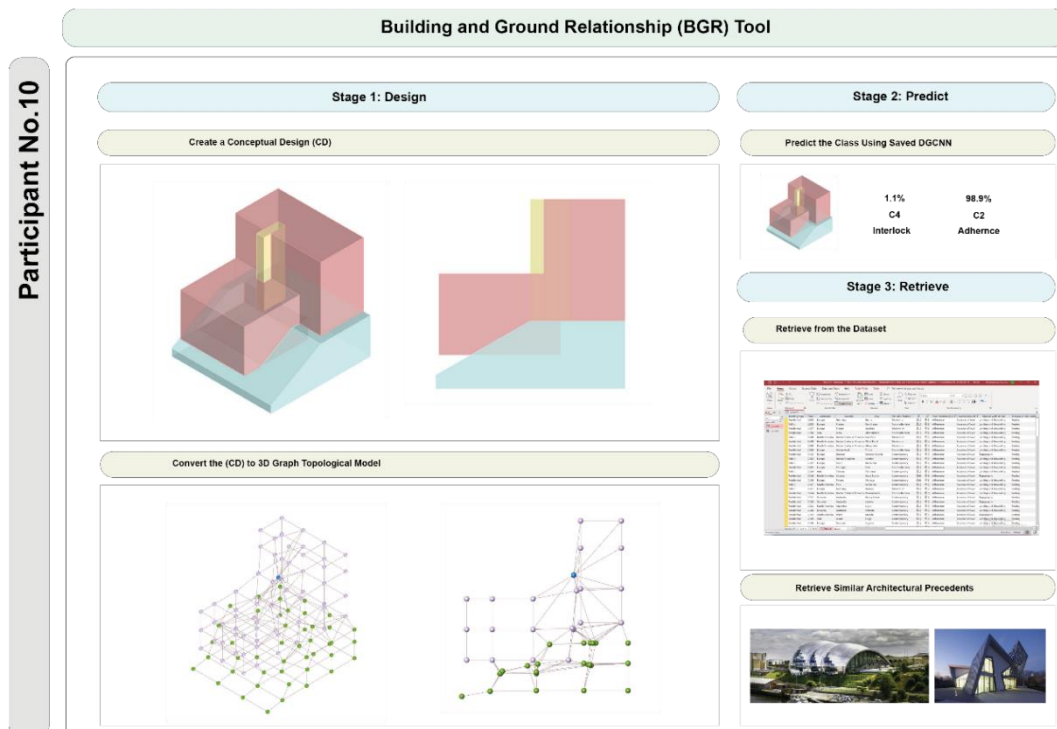

Figure 6.16: Solution produced by participant 10

Chapter 6: Computational Tool to Retrieving Similar Building and Ground Relationship Precedents (BGR Tool)

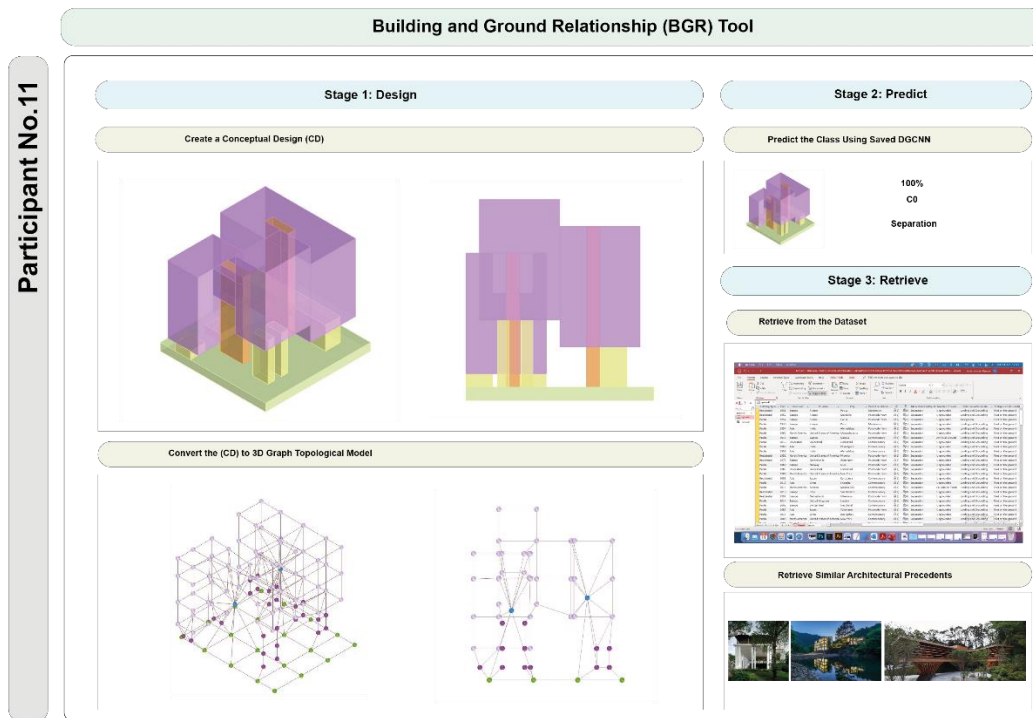

Figure 6.17: Solution produced by participant 11

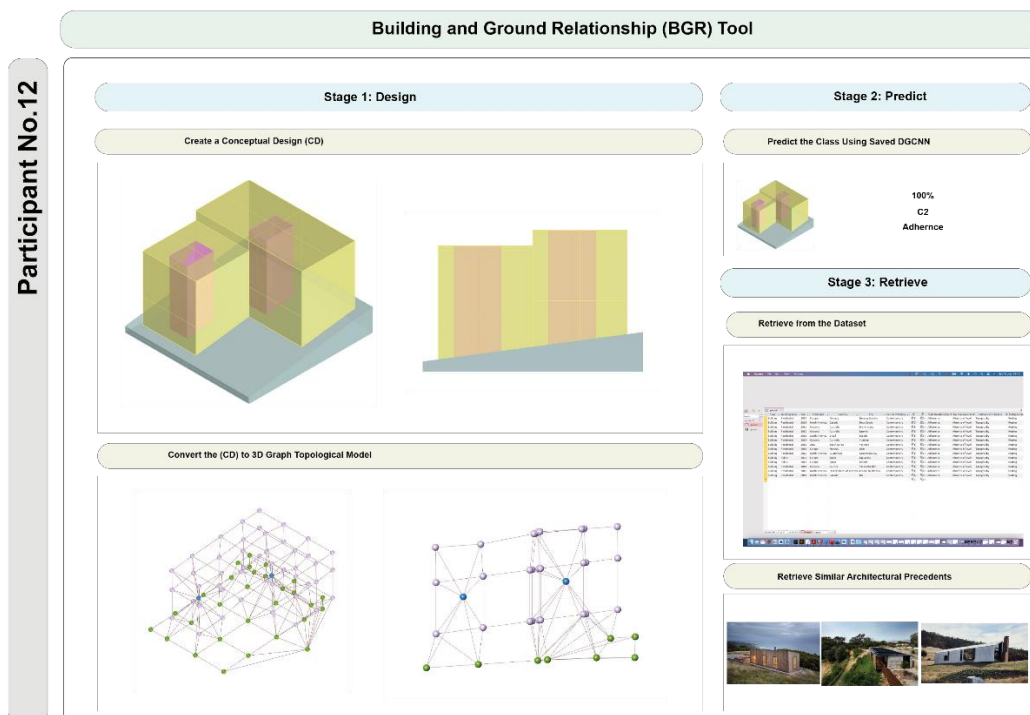

Figure 6.18: Solutions produced by participant 12

6.3.5. Results From the Usability Evaluation

In response to the questionnaire, most respondents indicated that they had positive opinions of the tool. The system usability scale analysis results indicate that the BGR tool has an acceptable score (Table 6.3). Participant responses indicate that question one, which measured the usability of the generative building and ground workflow, received a score of 69.8 out of 100, which is the “highest marginal level”. For the second questionnaire, which aims to evaluate the usability of DGCNN, participant responses indicate that DGCNN has received a score of 71.1 out of 100, which is a “good and acceptable”. Furthermore, the overall system, which assesses the usability of the entire system, received a rating of 74.37 out of 100, which is a “good and acceptable” level (Figure 6.19). Based on all previous SUS scores, the BGR tool appears to be an acceptable method for use in architectural education and practice.

Table 6.3: The results of the Usability evaluation using SUS

Questioners	Questioners Aims	SUS Score
Questioner 1	Measure the usability of the generative building and ground workflow	69.80
Questioner 2	Measure the usability of the DGCNN system.	71.10
Questioner 3	Measure the whole system’s usability.	74.37

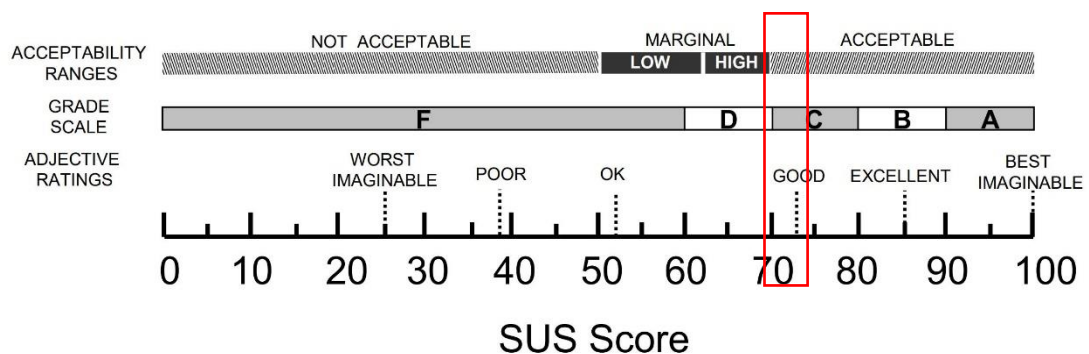

Figure 6.19: The system usability score of BGR tool

The following are the main findings of the evaluation based on their responses to questions and the comments they made during the implementation process:

a. Results of Participants’ Familiarity with the Used Tool

Even though participants do not need prior knowledge of the software used on the BGR tool, the following five questions are intended to measure participants' familiarity with the software associated with the BGR tool. The result indicates that 25% of participants are familiar with Visual Dataflow Programming. Most of the participants (66.67%) have no

Chapter 6: Computational Tool to Retrieving Similar Building and Ground Relationship Precedents (BGR Tool)

knowledge of Blender (Sverchok). However, approximately (41.6%) familiar with Grasshopper. In addition, 83% of the participants are either somewhat familiar or not familiar with Topologic. Lastly, the results indicate that the participants seem to be unfamiliar with DGCNN (Figure 6.20).

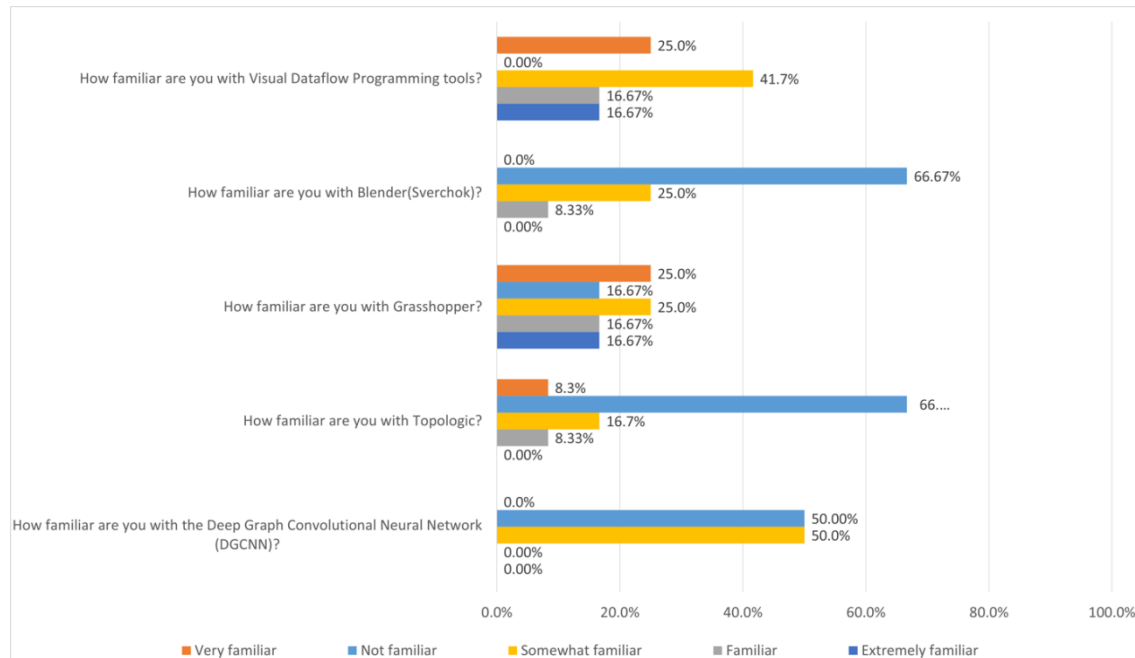

Figure 6.20: Results of participants' familiarity with the used tools

b. Results of the Usability of the Generative Building and Ground Workflow

The main findings of the results collected from this questionnaire have been summarised as follows (Figure 6.21) for more information about the results:

- 75% of the participants expressed a desire to frequently use the generative building and ground workflow.
- Approximately 66.6% of the participants disagree that the generative building and ground workflow is unnecessarily complex.
- Approximately 92% of the architects felt that the generative building and ground workflow was easy to use.
- Half of the architects (50%) feel that they don't need help from a technical person to use the generative building and ground workflow, and the other half believe that some assistance from a technical person would be helpful.
- Approximately 91% of the participants surveyed believe that the generative building and ground workflow were well integrated.
- Approximately 92% of participants do not agree that the generative building and ground workflow was inconsistent.

Chapter 6: Computational Tool to Retrieving Similar Building and Ground Relationship Precedents (BGR Tool)

- Approximately (66.6%) of the architects believe that the generative building and ground workflow will be relatively straightforward and quick to learn.
- Approximately (75%) of the participants do not agree that the generative building and ground workflow is cumbersome to use.
- Approximately (83%) of the participants expressed high levels of confidence in using the generative building and ground workflows.
- Approximately (33%) of the participants believe that they need to learn things before they can use the proposed generative building and ground workflow. Others (50%) were neutral on the issue.

c. Results of the Usability of the Deep Graph Neural Network System

As a result of this questionnaire, the following findings have been summarised (Figure 6.22) for more information about the results:

- Approximately 83% of the architects stated that they would frequently use DGCNN to classify their designs.
- Approximately (91%) of participants disagree that the DGCNN is unnecessarily complex.
- Approximately (75%) of the participants think that DGCNN is easy to use.
- Approximately (58%) of the participants believe they do not require technical assistance to use the DGCNN. The other, however, believe technical assistance would be useful.
- (83.3%) of the architects surveyed believe that the DGCNN was well integrated.
- Approximately (82%) of the participants do not agree that the DGCNN was inconsistent.
- Approximately (75%) of the participants thought that the DGCNN would be relatively simple to learn.
- Approximately (83%) of the participants do not agree that the DGCNN is cumbersome to use.
- Approximately (83%) of the participants expressed high levels of confidence in the DGCNN.
- Half of the architects believe that they must learn certain things to utilise the proposed DGCNN. However, the other half disagree or remain neutral on the matter.

d. Results of the Whole BGR Tool System's Usability

The following are the main findings derived from the results collected for this questionnaire: (Figure 6.23) for more information about the results:

- Approximately 91.7% of the participants indicated that they would frequently utilise BGR in their design practice or educational activities.

Chapter 6: Computational Tool to Retrieving Similar Building and Ground Relationship Precedents (BGR Tool)

- Approximately (83%) of the participants disagree that the BGR tool is unnecessarily complex.
- BGR tool was rated as easy to use by all the architect participants.
- Half of the participants (50%) believe that they do not need the assistance of a technical person to use the BGR tool, while the other half believe it would be helpful to have the assistance of a technical person.
- Approximately (81%) of the participants surveyed felt that the BGR tools were well integrated.
- The BGR tool was not inconsistent with (83%) of architects' opinions.
- Approximately (75%) of the participants believe that BGR will be relatively easy to use and simple to learn.
- Approximately (83%) of the participants do not find the BGR tool to be cumbersome.
- There was a high level of confidence among architects (91.7%) in using the BGR tool.
- Approximately (41,7%) of architects believe that they need to learn certain things to be able to use the proposed generative building and ground workflow. The remainder were neutral.

Chapter 6: Computational Tool to Retrieving Similar Building and Ground Relationship Precedents (BGR Tool)

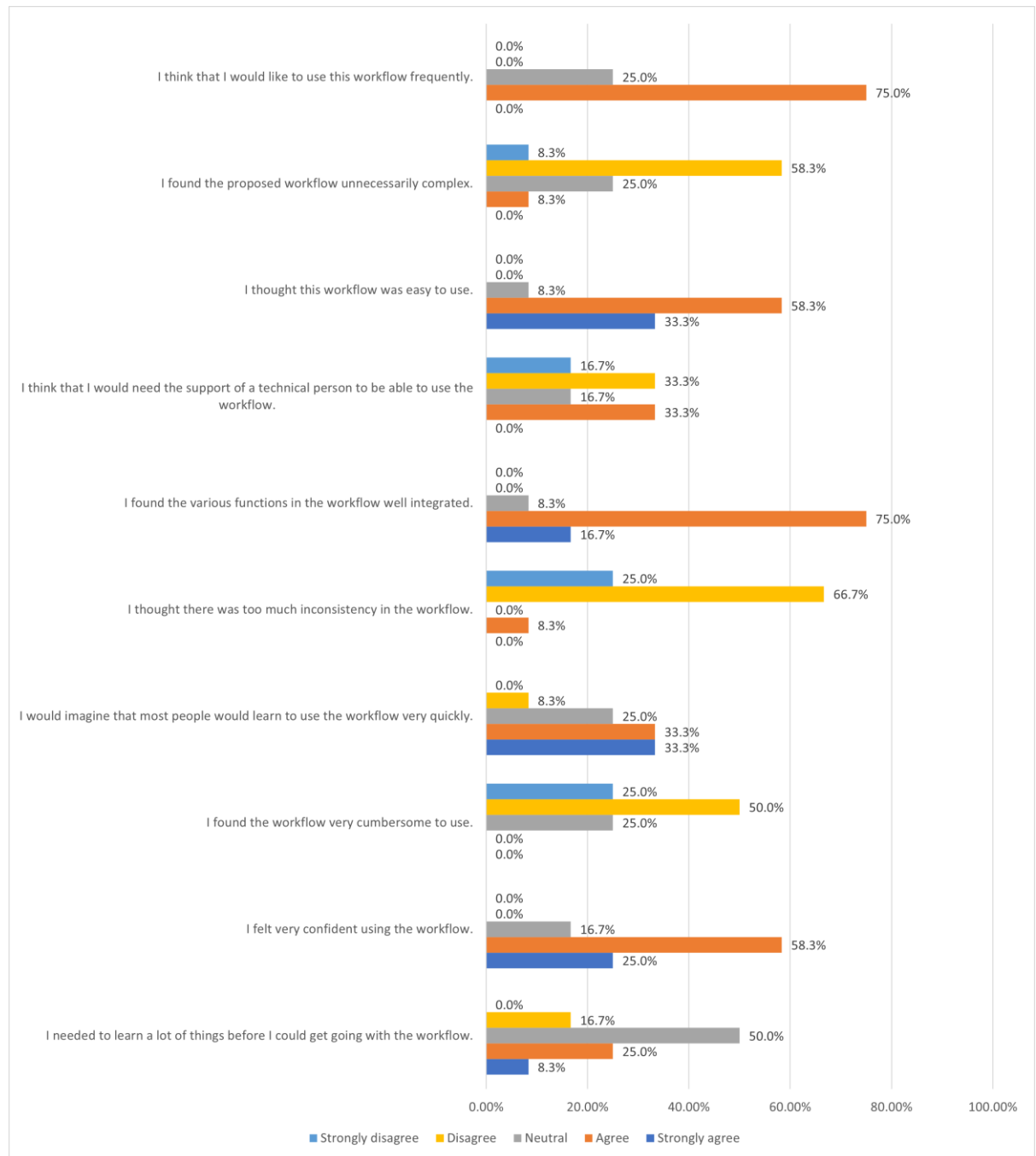

Figure 6.21: Results of the usability of the generative building and ground workflow

Chapter 6: Computational Tool to Retrieving Similar Building and Ground Relationship Precedents (BGR Tool)

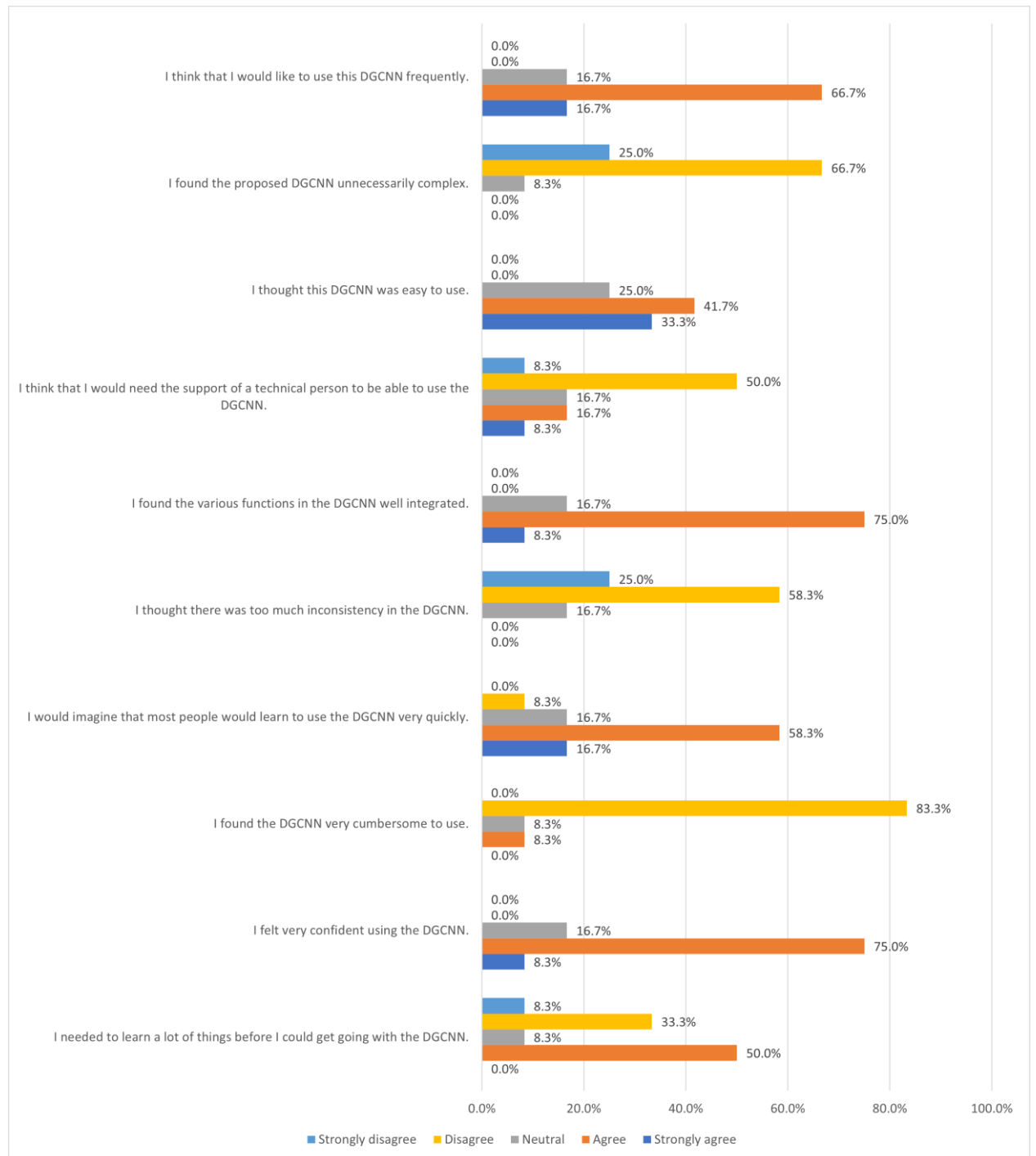

Figure 6.22: Results of the usability for the Deep Graph Neural Network system

Chapter 6: Computational Tool to Retrieving Similar Building and Ground Relationship Precedents (BGR Tool)

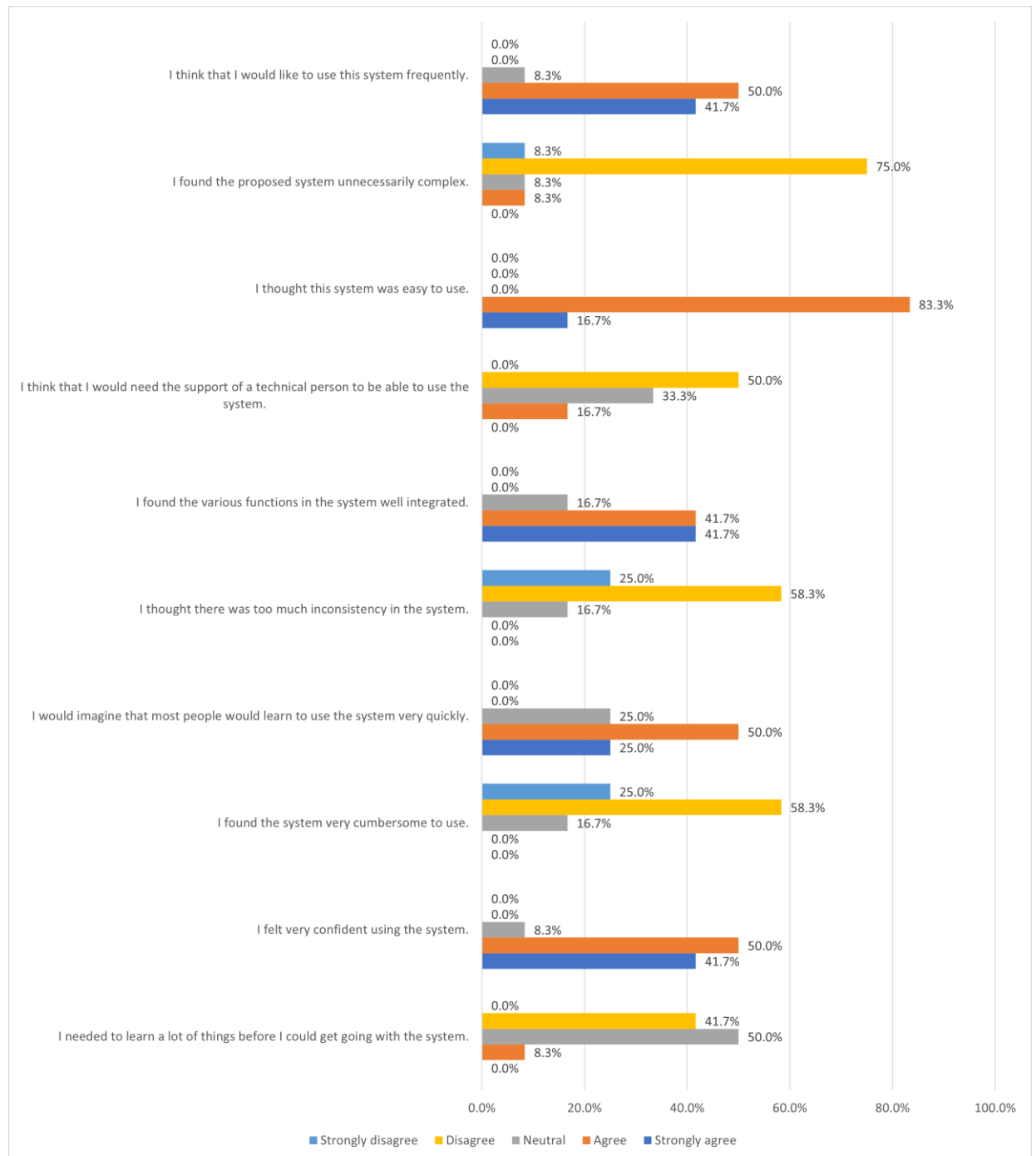

Figure 6.23: Results of the whole BGR tool system's usability

Participants identified the following as positive aspects of the tool:

- Remarkably accurate in predicting the results of the design. "Easy workflow".
- "This software will help architects in the future a lot and provide them with case studies".
- The use of different colours for each architectural element simplifies the visual understanding of the overall graph.
- Machine learning helps to accelerate the process significantly.
- "Looking forward to the next update."

Chapter 6: Computational Tool to Retrieving Similar Building and Ground Relationship Precedents (BGR Tool)

- “Interesting!! If I have a ground, is it possible to have the case studies before having the building designed?”.
- “Good luck!!” I am very impressed by the tool’s performance.

The users, however, suggested a list of matters to be considered regarding the enhancement of the interface:

- Addition of more information regarding building material and energy performance/ consumption.
- Addition of a link to access the precedents for further information and a closer look at the building.
- Addition of all the BGR tools as one node in Grasshopper to predict the design for the selected ground. Therefore, all steps need to be connected as one plugin.
- Finalisation of the system as a "plugin" will give better results and make it easier to control.
- Addition of more details to the design stage, such as windows, structural calculations, and materials.
- Allowance to the designers to change the permitted built-up area, the height of the building, and the bounce of the building from the surrounding area.

6.4. Chapter Summary

As determined through the assessment process and the usability test for the computational tool, the model successfully achieved its intended objective of designing, classifying, and retrieving similar precedents for the relationship between building and ground. In contrast to traditional methods, which focus on a single design solution, the BGR tool enables architects to think dynamically with multi-dimensional constraints and be able to retrieve similar designs that could help the architect to reconsider, develop, or change the first design solution.

Although the tool is limited to the small built-up and not complete as separate software, it gives the user the proposed objective. In addition, the tool allows developers to specify parameters such as the number of cores, the size, and the number of columns.

An evaluation of the usability of the tool indicates that most users found it useful for designing and retrieving similar architectural precedents. In addition, they indicated that they were interested in using the BGR tool at the early stage of the design so that they could investigate alternatives that would otherwise be hidden. As opposed to other applications, the BGR tool allows architects and students to complete the design in a short period of time.

CHAPTER SEVEN

RESEARCH DISCUSSION AND CONCLUSION

Chapter 7: Research Discussion and Conclusion

7.1. Introduction

The ground often acts as a passive foundation for going higher, but architects can also dig deeper into the rich and endless possibilities of buildings that merge with the surroundings and the earth (Mastenbroek et al. 2021). Architects tend to ignore the land's physical characteristics and use only their repertoire of methods to meet the ground; others take the flat terrain for granted without taking into consideration the terrain's geographical characteristics in terms of place and form. Understanding the typology of the link between the building and the ground can extrapolate relevant performative information that helps architects make more informed design choices.

The research motivation centres around the fact that digital aids must help architects identify building performance characteristics at an early stage of design for them to make informed design decisions. Performing this task manually can prove to be slow, costly, and prone to errors. The automatic classification methods used in the age of AI, and especially in the case of GML, have made it possible for designers to predict the performance of buildings and the ground during the design process. Thus, because of this framework, relevant precedents may be introduced into the design process, allowing the designer to quickly estimate the performance effects of the decisions they make in relation to the design. Although AI techniques have been used for several years to classify buildings, up to this point, they have taken their inspiration from 2D visual representations of building features. By using only pixel-level information, these systems lacked the capacity to use 3D information due to a reduction in their ability to analyse it. Yet, encoding and analysing a full 3D model is challenging and time-consuming for ML algorithms. A solution can be found in topological graphs that do not face any of the restrictions imposed by the limitations of 2D pixels, and, at the same time, do not place a burden on encoding a full 3D model. Consequently, the challenge shifts to the generation of topological graphs. A key learning outcome from this dissertation concerns the notion that practitioners must take into consideration the building's ground at the earliest stage of the design process before they have to manage the burden surrounding the complexity and rigidity of a fully developed BIM. Thus, this research advocates the derivation of topological graphs from conceptual models rather than fully developed ones. As the design field moves forward, different technologies, such as AI, are likely to play an increasingly crucial role in helping designers accomplish this objective.

Chapter 7: Research Discussion and Conclusion

The aim of this research is to help academic and practising architects understand and identify the typological and topological characteristics of their architectural building and ground syntax and place it within the most relevant architectural canons. Consequently, this approach accumulated a significant amount of knowledge regarding the various types of buildings and ground relationships.

Thus, because of the study, the following original contributions were made:

- The generation of a building and ground relationship taxonomy.
- The construction of building and ground parametric rules using shape grammars, extracted from collected precedents, and an image sorting survey.
- The development of a mechanism for generating 3D graph topological models of architectural building and ground relationships.
- The development of a workflow that implements graph machine learning classification using an architectural building and ground relationship.
- The development of building and ground relationship tools (BGR Tool).

7.2. Significance of the Findings and Research Contributions

This section provides a summary of the research findings and their contribution. The section comprises eight key findings that make contributions to the body of research knowledge.

7.2.1. A Collected Building and Ground Relationship Taxonomy

A great deal of discussion in the literature review has focused on the building and ground (Berlanda, 2014; Hensel and Turko, 2015; Porter, 2015, 2017; Mastenbroek *et al.*, 2021). Despite this, it remains worthwhile to note the lack of building and ground taxonomies. To the best of the researcher's knowledge, the resources of the building ground taxonomy are seldom found (Berlanda, 2014). This problem needs further exploration to support the architects in gaining a deeper understanding of all building and ground taxonomies and to provide guidelines for a first-stage design process through the classification of building and ground relationships.

Buildings can meet the ground in a variety of ways. Adherence, separation, and interlock constitute the three main building and ground relationships. All other approaches must fall into one of these three principal categories (Berlanda 2014). In addition, according to Berlanda, there are different types of building and ground relationships, each of which falls

Chapter 7: Research Discussion and Conclusion

into one of three principal categories: grounded, ungrounded, foundation, plinth, artificial ground, and absence of level.

Therefore, because of this collected taxonomy, the study explained the variety of approaches that can be applied to building and grounding relationships, which, in turn, simplified the identification of related approaches. Moreover, the taxonomy can help educate the young architects about the diversity of the building and ground relationship approaches that play a role in architectural discipline. Such an approach can also heighten their interest in taking the ground into consideration.

7.2.2. Clustering Building and Ground Relationship Using a Human Image Sorting Survey

Sorting techniques tend to involve asking a respondent to sort things into groups. The thing in question can be an object, picture, or card. The noteworthy aspect of using a sorting technique is to find out the level of agreement and disagreement a task may entail. Researchers have used image sorting to accomplish different objectives, such as studying how experts classify a specific set of objects. It becomes possible to determine their thoughts and feelings about a sorted topic by analysing the classified objects in groups. Examples of this tactic appear in (Hazlett, Figueroa and Nielson, 2015) and (Robinson *et al.*, 2016). Image sorting also helps researchers conduct a complex classification, such as the building and ground relationship, while card image sorting represents a convenient way for an expert to classify a set number of images into a specific group, which can help the researcher cluster this complex task (Morente-Molinera *et al.* 2019).

The “main building and ground” image sorting survey revealed an insightful finding: participants can encounter difficulties classifying interlock and adherence images. Approximately 20% of the adherence image underwent sorting in the interlock group and approximately 37% of the interlock image was sorted into the adherence group. Thus, as a result, the survey reveals that interlocking and adherence appear to be the most problematic areas. In addition, the "building meets the ground" image sorting survey revealed that participants had difficulties sorting the images of the foundation and plinth. Most participants missed grouping the foundation class with the grounded class (72 images). Therefore, the researcher merged these two classes into a single class. Participants incorrectly identified plinths as artificial ground (19 images). Therefore, the researcher also merged these two classes into a single class.

Chapter 7: Research Discussion and Conclusion

According to the image sorting survey, one significant finding was that the discovery of a taxonomy enables humans to classify buildings and ground relationships. Thus, as part of this taxonomy, the following relationships are used as machine learning classes:

- Separation: separation (Ungrounded), separation with plinth (Columns in plinth).
- Adherence: absences of level, adherence with plinth.
- Interlocked: grounded.

7.2.3. The Use of Architectural Precedents in Architectural Design

The study aimed to develop a computational model that can play a role in architectural design education and allow practitioners to make creative use of architectural precedents. Architectural design can gain leverage by connecting it to something else using design precedents. Moreover, it can help the designer to rethink the design ideas from the early stages. An architectural precedent study makes it possible to solve problems in the design process that were previously solved in other designs. The architectural design process relies heavily on precedent studies, whether through describing a construction method, a material choice, or a design concept. However, there exists no dataset of architectural precedents that documents the focus on the relationship between the building and the ground. By providing a database of more than 500 precedents in the field of architecture, this study filled a gap in the literature. In the archived data set, images do not constitute the only type of data that has been collected. The architect's name, building name, building stats, building type, the construction or design years, the building location (continent, country, and city) and the period of architecture history were collected for each case study. All these compiled pieces of information expanded the user's research. For example, the period of architectural precedents served as a restriction or expansion in research precedents.

This study uses architectural precedents to allow the user to retrieve case studies for review, education, and reconsideration of the design solution. In addition, the user has the ability to use them in other aspects of design, such as construction or structural design, building materials, building façades and designing building apertures.

In the study, the retrieved building and ground relationship process underwent examination, and the users agreed with the number of precedents retrieved during the examiner process (presented in Chapter 6). The research process saw a total of 1,651 architectural precedents retrieved from 12 different participants. The average number of architectural precedents per participant totalled 138.

7.2.4. The Process of Design Aided by Generative Design and Machine Learning

With generative design, architects can provide accurate and sophisticated architectural solutions in record time, which would otherwise prove impossible to achieve with traditional design methods. Even though generative design is not new to the world of architecture, its application has encountered limitations due to its complexity. This is because it requires expert architects to analyse a large amount of data in to arrive at the most suitable design. Due to the complexity of dealing with such a large amount of data and technology, many architects do not consider generative design a useful tool beyond iconic buildings and large projects. Nevertheless, if we combine machine learning with generative design tools, we can present them in a more practical and simpler way than ever before. Architects can take advantage of this integration to produce highly accurate and complete architectural designs that can play a viable role in their daily work. Such an approach can process different types of data related to building codes specific to each region or building relationships with different ground contexts. Thus, it can be utilised to design houses, apartment buildings, commercial centres, zoning, and the interiors of residential and commercial buildings. It can also be used in the analysis of spaces, relationships between rooms, privacy, wind direction, light and heat and so on. Rather than manually considering all these factors, AI technology can automate generative design processes in an efficient manner that considers all the previous factors in addition to many others. Using generative design and machine learning, designers are able to produce a large number of designs regardless of their skill level or experience. These designs can be manipulated within a short period of time.

7.2.5. Unsupervised Machine Learning to Cluster Similar Architectural Styles Using Architectural Precedents

According to the results of Chapter 5 (Part A), a new proof of concept workflow has been proposed to automatically detect different architectural designs in how a building interacts with its surroundings. After analysing a collection of architectural precedents, the researcher applied three ML algorithms and found that all three models performed well. The experiment obtained accurate results, proving that all machine learning algorithms have the capacity to cluster the problem accurately. However, according to the findings, K-means proved to be the most effective ML algorithm for this type of data. In the mixed data set containing both public and residential data, the K-means method consistently provided the most accurate results, which amounted to an approximate silhouette score of 0.69 (84.5%). Based on the experimental results for the residential data set, the K-means method again provided the most

Chapter 7: Research Discussion and Conclusion

accurate results, which amounted to an approximate silhouette score of 0.69 (84.5%). Finally, in the experimental results for the public data set, the K-means method yet again provided the most accurate results, which amounted to an approximate silhouette score of 0.70 (85%). Prior work has focused on categorising and clustering architectural styles using an image database (Shalunts, Gayane, Yll Haxhimusa 2011; Shalunts et al. 2012; Shalunts 2012; Chen et al. 2015; Lee and Lee 2016). While these approaches offer intriguing insights, they do not allow the machine to cluster the data without supervision or the tagging of images. To the best of the author's knowledge, no work has been conducted using unlabelled data (unsupervised) to cluster architectural styles to clarify the relationship between different architects' building styles and the ground. To fill this gap, this study uses unlabelled data (unsupervised) to cluster architectural styles to clarify how different architects' building styles relate to the ground. Moreover, most studies implement the clustering task using the K-means algorithm as a ML method (Shalunts, Gayane, Yll Haxhimusa 2011; Shalunts et al. 2012; Shalunts 2012; Chen et al. 2015; Lee and Lee 2016; Yousif and Yan 2018). This study used a similar clustering K-means algorithm. Although, in this study, the K-means clustering algorithm method achieved a higher level of accuracy than other clustering algorithms, the K-modes and GMM methods also achieved high accuracy results.

Consequently, categorising architects' styles according to their approach to the relationship between the building and the ground can divide a large database into specific historical periods, types of buildings and geographical regions. Fast and efficient retrieval of this data is enabled by these database groups.

7.2.6. Generating 3D Graph Topological Model of Architectural Building and Ground Relationship

The building and ground relationship is 3D, topologically connected, and complex. The lack of shareable 3D data sets creates a real challenge, and while some open-source sets do exist (Gröger and Plümer, 2012), their format, suitability, accessibility, and licensing vary. Even if 3D data sets become available, it remains tricky to recognise and classify them. The major challenge involves cleaning the data set and converting it from mesh geometry to abstracted topology. Moreover, ML requires a large amount of data to train the neural network, so the researcher utilised shape grammars to create a set of rules to develop a syntactical data set. In this study, the researcher used 500 case studies to create a large data set. The parameters of the building and ground underwent extraction from these case studies. Moreover, the image sorting survey revealed a similarity between the most common building and ground

Chapter 7: Research Discussion and Conclusion

relationships. A rule based on Tome Berland's taxonomy was also developed based on the lexicon and diagrams. Then shape grammars translated these relationships into rules (Berlanda 2014).

For the syntactical case study, the researcher developed prototype rules based on built architectural precedents. Grasshopper and Topologic then generated various 3D parametric models and their associated topological dual graphs. The size of the ground plate was fixed. The plinth was then dimensioned to be a percentage of the ground plate with equal offsets on all sides. The next step saw the building geometries placed with appropriate offsets and spacing. The buildings varied in height. Finally, the building geometries were subdivided internally into a grid of cells. A crucial point to note is that the internal sub-division of the building sought to assist the neural network in identifying structures of different heights rather than providing details at the room level. Based on the building and ground relationship, three categories of rules were created:

- Separation (of ground, building, core, columns, plinth).
- Adherence (of ground, building, core, plinth).
- Interlock (of ground, building, core).

Creating a data set required the completion of three tasks. Labelling the overall graph was the first step. Separation occurs when the building is elevated from the ground on columns (labelled as Class 0) or on a plinth and columns (labelled as Class 1). A building that adheres to the ground is set directly on the ground (labelled as Class 2) or on a plinth that rests on the ground itself (labelled as Class 3). Lastly, an interlocking structure is one which overlaps with the surrounding topography (labelled as Class 4).

The second task involved labelling the vertices. DGCNN requires labelling of both the overall graph and the vertices within it; in this data set, the vertices were labelled in accordance with five categories: Ground (0), Plinth (1), Columns (2), Building (3) and Core (4). Generated models are aware of the categories in which they belong, as well as the types of nodes within them. Consequently, the graph label and node labels can be assigned correctly when exporting to DGCNN.

To meet the DGCNN format requirements, the final step involved integrating the visual dataflow definition along with a Python script to convert the 3D dual graph created by Topologic into a text file that would comply with the format requirements for DGCNN. Consequently, the generated 3D topological building and ground relationship data sets can be summarised as follows:

Chapter 7: Research Discussion and Conclusion

- The flat ground has three main relationship forms: separation, adherence, and interlock. This section produced 240 iterations.
- The sloped ground has three primary relationship forms: separation, adherence, and interlock. This section produces a total of 684 iterations.
- Level ground (Topographical ground) has three main relationship forms: separation, adherence, and interlock. This section produced a total of 1,242 iterations.

Iterative and nested loops synthesise the data set, resulting in a sequential list that is not random. To prevent a bias in training, the final list of graphs underwent random reordering to avoid testing only a specific level of complexity.

7.2.7. Graph Machine Learning Classification Using Architectural Building and Ground Relationship Precedents

This study aimed to implement GML models to classify building and ground relationships utilising graph theory. The study examined different approaches to classifying the building and ground relationship using GML. The Deep Graph Convolutional Neural Network (DGCNN) classifies 3D building and ground relationship data sets based on their topology. The application of morphology based on the shared connection between buildings and the ground aided this research. The BGR data set trained the DGCNN for graph classification. The results underwent verification using the Deep Graph Library (DGL) machine learning algorithm. Furthermore, unsupervised machine learning approaches have also undergone examination in this investigation. Such an unsupervised learning process generates a representation from unlabelled data, which can be used for downstream tasks, such as classification.

The experiment started with tuning the hyperparameters of the DGCNN approach. Optimised models were saved for testing with unseen data. DGCNN then predicted new scenarios that had never been trained previously. The data set includes a total of 2,136 graphs. The data set was initially divided into training, validation, and testing sets. A total of 2,136 graphs were divided by 35% training, 35% testing and 30% validation. A random search method created a grid of possible values for each parameter in this experiment.

The best model parameter was determined after 23 experiments. The optimal parameters of the model included two convolutional layers of 32 neurons each, 128 hidden layers for the final dense layers, 200 epochs, a 1-e4 learning rate and a batch size of 1. A 99.1% accuracy was achieved with an average loss of 0.044. After the training data set tuned the hyperparameters, the best-performing model was saved and tested on the test set.

Chapter 7: Research Discussion and Conclusion

There were 640 predicted data points in the confusion matrix. Ultimately, 633 examples underwent correct classification: with only 7 being mis-classified into Class 2 and Class 4. Two of the examples should have been classified as Class 2, but their values were incorrectly classified as Class 4. In addition, five of the examples were incorrectly classified as Class 2 when their actual values mandated classification as Class 4. Therefore, it remains crucial to note that Classes 0, 1, and 3 proved accurate. The model performed well in both Classes 2 and 4 despite the 7 errors.

Using the best-saved model enabled predictions of 12 new architectural precedents. Each new scenario was correctly predicted despite having different topological elements from the trained ones. This included a building with two cores, an L-shaped building, two buildings with different heights, a building that dips completely underground and a building partially set on a plinth, while other portions are raised above the ground.

The study assessed the DGCNN results using the Deep Graph Library (DGL) machine learning algorithms with the same data set. DGL achieved 98.4% accuracy with a 0.1 error loss. In the DGL, the most suitable structure comprised one hidden layer with 32 neurons, Adam optimizer, Convolution layer type SAGEConv, a train and test split ratio of 80-20%, MaxPooling layer, 100 epochs, five batches and a 0.001 learning rate. After training the DGL, 640 unseen data sets tested the DGL model. Over 98% of the model's predictions proved accurate. Only 13 cases were incorrectly classified in the 640 data sets, with the model correctly predicting 627 cases.

The final step involved implementing unsupervised graph-level representation learning (UGLRL). Unsupervised learning generates a representation of unlabelled data, which can be used for downstream tasks, such as classification, in the future. Based on semantically relevant and structured data, the approach shows promise for recognising architectural forms. Experimental results showed that all four accuracy measures, Logreg, SVC, Linear SVC and Random Forest, achieved high representation learning with more than 98% accuracy.

Based on the results obtained from the DGCNN and the DGL experiments, it can be concluded that both models have learned to effectively to classify the relationship between the building and the ground. While the results of this study cannot undergo comparison with benchmark data sets, the results achieved in this study align with the accuracy results DGCNN achieves when using benchmark data sets. Consequently, the study has been able to utilise all DGCNN's capabilities. Therefore, the DGCNN and DGL approaches show strong promise for recognising architectural forms using more semantically relevant and structured data. Moreover, the

results obtained from (UGLRL) achieved the study objective: to provide a vector for each graph to encode the relationship similarity between two 3D building and ground topological graphs.

7.2.8. Building and Ground Relationship Tool (BGR Tool)

Developing a computational tool with an easy-to-use interface has helped to simplify the workflow process for architects. Early in the design process, the tool assist architects in making informed decisions. A workflow tool has been developed that consists of three major stages: creation, implementation, and retrieval. The building ground relationship object is created, the DGCNN model is implemented to predict the 3D graph of the conceptual design, and similar precedents are retrieved.

The produced tool can benefit architectural practice and architectural education in the following areas:

- In the early design stage, the practitioner can use the tool to classify their concept regarding the building and ground relationship.
- By retrieving similar architectural precedents, the architectural practitioner can improve, change, or mix different concepts regarding the relationship between the building and the ground.
- By educating the architects to consider a variety of different approaches to how the building can meet the ground.

The usability and effectiveness of a computational tool undergo testing and evaluation after its development. Since it is a low-cost method of assessing the ease of use of systems, the System Usability Scale (SUS) suits this process. The SUS twice evaluated each component of the system separately. The first assessed the usability of the generative building and ground workflow, while the second evaluated the usability of the Deep Graph Neural Network (DGCNN) system. After that, SUS once more assessed the usability of the entire system.

Initially, participants were asked to design a building that satisfied the following criteria:

- Depending on the type of ground, an individual may choose flat ground, sloped ground, or stepped ground.
- Building objects and cores are not limited in number.
- There are no restrictions on the height or number of floors.
- Plinths and columns are required if the participant intends to design the relationship as separation with plinth or adherence with plinth.

Chapter 7: Research Discussion and Conclusion

Therefore, these constraints enable the user to come up with various solutions while also providing an opportunity for the researcher to assess the tool's practicality in generating alternatives.

The model has successfully achieved its intended objective of designing, categorising, and retrieving similar precedents for the relationship between the building and the ground, as determined by the assessment process and the usability test for the computational tool. Contrary to traditional methods that focus on a single design solution, the BGR tool allows architects to consider multidimensional constraints dynamically and identify similar designs that can reconsider, develop, or modify the first design solution.

Based on an evaluation of the tool's usability, it appears that most users found it suitable for designing and retrieving similar architectural precedents when designing their own buildings. The system scored 74.37 out of 100, a rating that indicates that it is a good and acceptable tool for the above purpose. Additionally, the participants indicated their interest in using the BGR tool at an early stage of the design process so that they could examine alternatives that would otherwise go unnoticed during the initial design phase. In comparison to other applications, the BGR tool allows architects and students to complete the design process in a shorter period. The average time taken by all participants to complete the task was 28 minutes.

7.3. Research Limitations

Although this study has provided encouraging results, some limitations nevertheless require attention:

- The research used the conventional building and ground relationship, which comprises separation, separation with plinth, adherence, adherence with plinth and interlock. In addition, this study only addressed the issue of an architectural object's relationship to the ground. Its applicability to other types of architecture is yet to be determined.
- Extracting building and ground relationship rules from 500 architectural precedents to fill the lack of "real" data sets created a synthetic data set. For real data sets to show their suitability for dual graph extraction, the researcher should note that they may require modification and translation.
- The synthetic data set was limited to five architectural elements with high semantic richness: the building, the ground, the plinth, the columns, and the cores. It is yet

Chapter 7: Research Discussion and Conclusion

unknown if adding more semantically rich information will result in a more comprehensive picture.

- Numerous alternative clustering algorithms can cluster the architecture styles of the building and ground relationship, such as KMedoids, KMedians, and fuzzy C-means, that can act as alternatives to the three unsupervised machine learning algorithms used in the study.
- Although DGCNN offered high accuracy, sometimes the model can misclassify adherence (Class 2), as an interlock (Class 4) and vice-versa. A similar interpretation can apply to the relationship between the building node (level one) and the ground node in the adherence class. Adding more building node labelling can resolve this issue. Adding more labels to building levels one, two and three, for example, may prove necessary. The topological graph relationship can be distinguished by this method depending on whether building level one is buried in the ground or if it is connected to the ground by building level two. However, this will result in geometrical information being added and not just topological information.
- Despite the tool helping the user achieve the proposed objective, switching between the different software platforms presented some challenges.
- The generated syntactical 3D graph topological dataset was limited to 2136 elements. The size of the initial set may limit the capabilities of ML models.

7.4. Recommendations for Future Work

Rather than representing a final solution, this research study aims to contribute to the body of knowledge in an ongoing manner. Therefore, future research should focus on the following:

- Adding more semantically rich information to the building and ground data set, such as windows (aperture) environmental analysis, more building context and building throwback, will result in a more comprehensive picture.
- Applying these approaches to a real 3D BIM data set building with different research orientations.
- It is intended that future work will focus on applying this approach to different types of data to generalise it. This research will serve as a foundation for future studies that will employ unsupervised ML algorithms to solve similar clustering problems in the architectural discipline.
- The DGCNN results have identified several new research areas. The first step will involve classifying nodes rather than just the overall graph. Among other future plans,

Chapter 7: Research Discussion and Conclusion

this technique will act as a fitness function within an evolutionary algorithm to generate and evaluate design options.

- Despite this, this study focused on the field of architectural design. The approach's applicability to other typologies remains to be determined in future studies.
- The same data set will undergo classification using a semi-supervised graph level representation learning technique, and the results will undergo comparison with those obtained using an unsupervised graph level representation learning technique.
- The BGR tool includes three steps: creating the building and ground relationship object, implementing the saved DGCNN machine learning model for prediction and retrieving similar architecture precedents. A work in progress to compile all these stages into one Blender tool using DGL.
- After creating and evaluating the BGR tool, the created tool needs to explain how this tool impacts architectural processes and the mental process of acquiring knowledge via the senses to experience the BGR tool.

REFERENCES

References

References

Aish, R., Jabi, W., Lannon, S., Wardhana, N. and Chatzivasileiadi, A. 2018. Topologic: tools to explore architectural topology. *AAG 2018: Advances in Architectural Geometry 2018* (September), pp. 316–341.

Aish, R. and Pratap, A. 2013. Spatial Information Modeling of Buildings Using Non-Manifold Topology with ASM and DesignScript. *Advances in Architectural Geometry 2012* (February). doi: 10.1007/978-3-7091-1251-9.

Aksamija, A. 2017. *Integrating innovation in architecture: Design, methods and technology for progressive practice and research*. John Wiley & Sons.

Akšamija, A. 2021. *Research methods for the architectural profession*. doi: 10.4324/9781003002932.

Alexander, C. 1964. *Notes on the synthesis of form*. Cambridge, Mass.: Harvard University Press.

Alexander, C. 1977. *A pattern language : towns, buildings, construction*. 36. print. New York NY: Oxford Univ. Press. Available at: http://www.worldcat.org/title/pattern-language-towns-buildings-construction/oclc/931400468&referer=brief_results [Accessed: 25 October 2018].

Al-Jokhadar, A. (Moh'D I. 2018. Towards a socio-spatial parametric grammar for sustainable tall residential buildings in hot-arid regions: Learning from the vernacular model of the Middle East and North Africa. (January)

Allen, Stan. and McQuade, M. 2011. *Landform building : architecture's new terrain*. Lars Müller Publishers.

Arabie, P. and Boorman, S.A. 1973. Multidimensional scaling of measures of distance between partitions. *Journal of Mathematical Psychology* 10(2), pp. 148–203.

Arets, Wiel., Costa, X. and Binet, H. 2002. *Wiel Arets : [works, projects, writings]*. New York: Princeton Architectural Press.

Arnold, F. and Cling, D. 2002. *Transmettre en architecture : de l'héritage de Le Corbusier à l'enseignement de Henri Ciriani*. Paris: Le Moniteur.

Artigas, R. 2007. *Paulo Mendes da Rocha: Fifty Years (Projects 1957-2007)*. New York N.Y.

Atwood, J. and Towsley, D. 2016. Diffusion-convolutional neural networks. *Advances in Neural Information Processing Systems (Nips)*, pp. 2001–2009.

Bai, Y. et al. 2019a. Unsupervised inductive graph-level representation learning via graph-graph proximity. *IJCAI International Joint Conference on Artificial Intelligence 2019-Augus*, pp. 1988–1994. doi: 10.24963/ijcai.2019/275.

Bai, Y. et al. 2019b. Unsupervised Inductive Whole-Graph Embedding by Preserving Graph Proximity. In: *ICLR 2019 Workshop: Representation Learning on Graphs and Manifolds.*, pp. 1–21.

References

- Balmori, Diana. and Sanders, J. 2011. *Groundwork : between landscape and architecture*. Monacelli Press.
- Bassey, M. 1999. *Case study research in educational settings*. McGraw-Hill Education (UK).
- Bazeley, P. 2020. Qualitative data analysis: Practical strategies. *Qualitative Data Analysis* , pp. 1–584.
- Beetz, J. 2014. A Scalable Network of Concept Libraries Using Distributed Graph Databases. *Computing in Civil and Building Engineering* , pp. 955–1865.
- Bell, E., Bryman, A. and Harley, B. 2022. *Business research methods*. Oxford university press.
- Berg, A.C., Grabler, F. and Malik, J. 2007. Parsing images of architectural scenes. *Proceedings of the IEEE International Conference on Computer Vision* . doi: 10.1109/ICCV.2007.4409091.
- Berlanda, T. 2014. *Architectural Topographies: a graphic lexicon of how buildings touch the ground*. Available at: <http://search.lib.virginia.edu/catalog/u6268613> [Accessed: 17 October 2018].
- Bholowalia, P. and Kumar, A. 2014. EBK-Means: A Clustering Technique based on Elbow Method and K-Means in WSN. *International Journal of Computer Applications* 105(9), pp. 975–8887.
- Blaikie, N. 2003. *Analyzing Quantitative Data*. (SAGE Publications Ltd)
- Bonacic, V., Gips, J. and Stiny, G. 1977. *Shape Grammars and Their Uses: Artificial Perception, Shape Generation and Computer Aesthetics*. doi: 10.2307/1573793.
- Bosley, S.L.C., A.J. and C.L. 2009. How other people shape our careers: A typology drawn from career narratives' (2009) ', , 62(10),. *Human Relations* 62(10), pp. 1487–1520.
- Britannica, T.E. 2010. Graph Theory Summary. Available at: <https://www.britannica.com/summary/graph-theory> [Accessed: 15 August 2022].
- Broadbent, G. 1973. *Design in Architecture: Architecture and the Human Sciences*. Wiley. Available at: https://books.google.com.sa/books?id=-_YoswEACAAJ.
- Brooke, J. 1995. SUS: A “Quick and Dirty” Usability Scale. *Usability Evaluation In Industry* (November 1995), pp. 207–212. doi: 10.1201/9781498710411-35.
- Brooke, J. 2013. SUS : A Retrospective. *Journal of usability studies* 8(January 2013), pp. 29–40.
- Brownlee, J. 2017. Why One-Hot Encode Data in Machine Learning? Available at: <https://machinelearningmastery.com/why-one-hot-encode-data-in-machine-learning/>.
- Bruna, J., Zaremba, W., Szlam, A. and LeCun, Y. 2014. Spectral networks and deep locally connected networks on graphs. *2nd International Conference on Learning Representations, ICLR 2014 - Conference Track Proceedings* , pp. 1–14.
- Bryman, A. 2012. *Social Research Methods*. Fourth edi. Oxford University Press Inc., New York.
- Bryman, A. 2016. *Social research methods*. Fifth edit. Oxford University Press Inc., New York.

References

Cagdas, G. 1996. A shape grammar: The language of traditional Turkish houses. *Environment and Planning B: Planning and Design* 23(4), pp. 443–464. doi: 10.1068/b230443.

Cai, H., Zheng, V.W. and Chang, K.C.C. 2018. A Comprehensive Survey of Graph Embedding: Problems, Techniques, and Applications. *IEEE Transactions on Knowledge and Data Engineering* 30(9), pp. 1616–1637. doi: 10.1109/TKDE.2018.2807452.

Camburn, B. et al. 2017. Design prototyping methods: state of the art in strategies, techniques, and guidelines. *Design Science* 3

Carley, K.M. 1996. Validating computational models. *Working Paper* 0793(September), pp. 1–24. Available at: <http://reports-archive.adm.cs.cmu.edu/anon/anon/home/ftp/usr0/ftp/isr2017/CMU-ISR-17-105.pdf>.

Carrasco, O.C. 2019. Gaussian Mixture Models Explained. Available at: <https://towardsdatascience.com/gaussian-mixture-models-explained-6986aaf5a95>.

Chaillou, S. 2019. The Advent of Architectural AI - A Historical Perspective. *Towards Data Science*, pp. 1–17.

Chang, T.-W. and Woodbury, R. 1997. Efficient Design Spaces of Non-Manifold Solids. In: *Efficient Design Spaces of Non-Manifold Solids*. The Second conference on Computer-Aided Architectural Design Research in Asia (CAADRIA), p. 335.

Chaturvedi, A., Fooda, K. and Green, P. 2001. K-modes Clustering. *Journal of Classification*, pp. 36–55.

Chatzivasileiadi, A., Lannon, S., Jabi, W., Wardhana, N.M. and Aish, R. 2018a. Addressing pathways to energy modelling through non-manifold topology. *Simulation Series* 50(7), pp. 31–38. doi: 10.22360/simaud.2018.simaud.005.

Chatzivasileiadi, A., Wardhana, N., Jabi, W., Aish, R. and Lannon, S. 2018b. A Review of 3D Solid Modeling Software Libraries for Non-Manifold Modeling. *Proceedings of CAD'18* (July), pp. 59–65. doi: 10.14733/cadconfp.2018.59-65.

Chen, K.W., Janssen, P. and Schlueter, A. 2015a. Analysing Populations of Design Variants Using Clustering and Archetypal Analysis. In: *Proceedings of the 33rd eCAADe Conference.*, pp. 251–260. Available at: http://papers.cumincad.org/data/works/att/ecaade2015_55.content.pdf [Accessed: 29 January 2019].

Chen, K.W., Janssen, P. and Schlueter, A. 2015b. Analysing Populations of Design Variants Using Clustering and Archetypal Analysis. In: *Proceedings of the 33rd eCAADe Conference.*, pp. 251–260. Available at: http://papers.cumincad.org/data/works/att/ecaade2015_55.content.pdf [Accessed: 29 January 2019].

Chiou, S.C. and Krishnamurti, R. 1995. The grammar of Taiwanese traditional vernacular dwellings. *Environment & Planning B: Planning & Design* 22(6), pp. 689–720. doi: 10.1068/b220689.

Chipperfield, David. 1994. *Theoretical practice*. London: Artemis.

References

Christensen, L.B., Johnson, B., Turner, L.A. and Christensen, L.B. 2011. Research methods, design, and analysis.

Cohen, J.-Louis., Lautner, J., Olsberg, R.N., Escher, Frank. and Museum., H. 2008. *Between earth and heaven : the architecture of John Lautner*.

Colakoglu, B. 2005. Design by grammar: An interpretation and generation of vernacular hayat houses in contemporary context. *Environment and Planning B: Planning and Design* 32(1), pp. 141–149. doi: 10.1068/b3096.

Collins, F.C., Braun, A., Ringsquandl, M., Hall, D.M. and Borrmann, A. 2021. Assessing IFC classes with means of geometric deep learning on different graph encodings. *Proceedings of the 2021 European Conference on Computing in Construction 2*, pp. 332–341. doi: 10.35490/ec3.2021.168.

Collins, P. 1998. *Changing ideals in modern architecture, 1750-1950*. 2nd ed. Montreal: Montreal : McGill-Queens University Press.

Corner, J. 1999. Recovering Landscape: Essays in Contemporary Landscape Theory., p. 287. Available at: https://www.worldcat.org/title/recovering-landscape-essays-in-contemporary-landscape-architecture/oclc/799442431&referer=brief_results [Accessed: 30 December 2018].

Correia, R.C. 2013. DESIGNA -A Shape Grammar Interpreter. *Tecnico Lisboa* (June)

Creswell, J.W. 2009. *Research design : qualitative, quantitative, and mixed methods approaches*. 3rd ed. Thousand Oaks, CA : Thousand Oaks, CA .

Creswell, J.W. 2014. *Research Design: qualitative, quantitative, and mixed methods approaches*. 4th ed. Thousand Oaks, CA.

Cross, N. 1984. *Introduction to the management of design process*. New York: John Wiley and Sons Ltd.

Cross, N. 2001. Designerly Ways of Knowing: Design Discipline Versus Design Science. *Design Issues* 17(3), pp. 49–55. doi: 10.1162/074793601750357196.

Crotty, M. 1998. *The foundations of social research : meaning and perspective in the research process*. London ; Thousand Oaks, Calif.: Sage Publications.

Dai, H., Kozareva, Z., Dai, B., Smola, A. and Song, L. 2018. Learning Steady-States of Iterative Algorithms over Graphs. In: Dy, J. and Krause, A. eds. *Proceedings of the 35th International Conference on Machine Learning*. Proceedings of Machine Learning Research. PMLR, pp. 1106–1114. Available at: <https://proceedings.mlr.press/v80/dai18a.html>.

Day, E. 1981. *Ellen Day Hale, 1855-1940 : [exhibition] October 17 - November 14, 1981, Richard York Gallery*. New York, N.Y.: The Gallery.

Defferrard, M., Bresson, X. and Vandergheynst, P. 2016. Convolutional neural networks on graphs with fast localized spectral filtering. *Advances in Neural Information Processing Systems (Nips)*, pp. 3844–3852.

References

Denscombe, M. 2008. Communities of practice: A research paradigm for the mixed methods approach. *Journal of mixed methods research* 2(3), pp. 270–283.

Deplazes, A. 2005. *Constructing architecture : materials, processes, structures, a handbook*. Available at: <http://fama.us.es/record> [Accessed: 17 November 2018].

De Roure, D. and Willcox, P. 2017. Experimental humanities: An adventure with lovelace and babbage. *Proceedings - 13th IEEE International Conference on eScience, eScience 2017* , pp. 194–201. doi: 10.1109/eScience.2017.32.

Derix, C. and Jagannath, P. 2014. Digital intuition – Autonomous classifiers for spatial analysis and empirical design. *The Journal of Space Syntax* 5(2), pp. 189–215.

Dharmarajan, A. and Velmurugan, T. 2016. Efficiency of k-Means and k-Medoids Clustering Algorithms using Lung Cancer Dataset. *International Journal of Data Mining Techniques and Applications* (150), pp. 150–156.

Dino, I.G. 2012a. Creative design exploration by parametric generative systems in architecture. *Metu Journal of the Faculty of Architecture* 29(1), pp. 207–224. doi: 10.4305/METU.JFA.2012.1.12.

Dino, I.G. 2012b. Creative design exploration by parametric generative systems in architecture. *Metu Journal of the Faculty of Architecture* 29(1), pp. 207–224. doi: 10.4305/METU.JFA.2012.1.12.

Downing, F. and Flemming, U. 1981. The Bungalows of Buffalo. *Environment and Planning B: Planning and Design* 8(3), pp. 269–293. doi: 10.1068/b080269.

Duarte, J.P. 2001. Customizing Mass Housing: A Discursive Grammar for Siza's Malagueira Houses. *PhD Dissertation*

Duarte, J.P. 2005. A discursive grammar for customizing mass housing: The case of Siza's houses at Malagueira. *Automation in Construction* 14(2 SPEC. ISS.), pp. 265–275. doi: 10.1016/j.autcon.2004.07.013.

Eilouti, B. 2012. Sinan and Palladio: Two cultures and nine squares. *International Journal of Architectural Heritage* 6(1), pp. 1–18. doi: 10.1080/15583058.2010.495821.

Eilouti, B.H. and Al-Jokhadar, A.M.I. 2007. A computer-aided rule-based mamluk madrasa plan generator. *Nexus Network Journal* 9(1), pp. 31–58. doi: 10.1007/s00004-006-0028-4.

Eisenstadt, V. et al. 2021a. Evaluation of Data Representations for Deep Learning Methods in. 1, pp. 45–54.

Eisenstadt, V., Arora, H., Ziegler, C., Bielski, J., Langenhan, C., Althoff, K.D. and Dengel, A. 2021b. Exploring optimal ways to represent topological and spatial features of building designs in deep learning methods and applications for architecture. *Projections - Proceedings of the 26th International Conference of the Association for Computer-Aided Architectural Design Research in Asia, CAADRIA 2021* 1(DI), pp. 191–200.

Eloy, S. and Duarte, J.P. 2011. A Transformation Grammar for Housing Rehabilitation. *Nexus Network Journal* 13(1), pp. 49–71. doi: 10.1007/s00004-011-0052-x.

References

- Ezzat, M. 2020. A Framework for a Comprehensive Conceptualization of Urban Constructs. In: *RE: Anthropocene, Design in the Age of Humans - Proceedings of the 25th International Conference on Computer-Aided Architectural Design Research in Asia, CAADRIA 2020.*, pp. 111–120.
- Fernndez Galiano Herzog & de Meuron., L.A. 2019. *Herzog & de Meuron : 1978-2002*. Madrid: Arquitectura Viva.
- Ferrando, C., Mai, J., Llach, D. and Dalmaso, N. 2019. Architectural Distant Reading. *CAADFutures* , pp. 204–217.
- Fillenbaum, S. and Rapoport, A. 1974. Verbs of judging, judged: A case study. *YVLVB Journal of Verbal Learning and Verbal Behavior* 13(1), pp. 54–62.
- Flemming, U. 1987. More than the sum of parts: the grammar of Queen Anne houses. *Environment and Planning B: Planning and Design* 14(3), pp. 323–350. doi: 10.1068/b140323.
- Franz, G., Mallot, H.A. and Wiener, J.M. 2005. Graph-based models of space in architecture and cognitive science- a comparative analysis. *Proceedings of the 17th International Conference on Systems Research, Informatics and Cybernetics* , pp. 30–38. Available at: <http://eprints.bournemouth.ac.uk/13803/1/licence.txt>.
- Gall, B. and Borg, W. 2002. Gall.(1996). *Educational Research: Una introducción*
- Gallicchio, C. and Micheli, A. 2010. Graph echo state networks. *Proceedings of the International Joint Conference on Neural Networks* , pp. 1–8. doi: 10.1109/IJCNN.2010.5596796.
- Géron, A. 2017. *Hands-On Machine Learning with Scikit-Learn and TensorFlow*. O’Reilly Media.
- Geron, A. 2019. *Hands-on Machine Learning with Scikit-Learn, Keras and Tensorflow*. O’Reilly Media.
- Gilbert, N. and Stoneman, P. 2015. *Researching social life*. Forth edit. Sage Publications Ltd.
- Gilmer, J., Schoenholz, S.S., Riley, P.F., Vinyals, O. and Dahl, G.E. 2017. Neural message passing for quantum chemistry. *34th International Conference on Machine Learning, ICML 2017* 3, pp. 2053–2070.
- Glaser, D. and Peng, J. 2003a. On Classifying Daylight for Design. *International Journal of Architectural Computing* 1(2), pp. 205–217. Available at: <http://papers.cumincad.org/data/works/att/ijac20031206.content.pdf> [Accessed: 29 January 2019].
- Glaser, D. and Peng, J. 2003b. On Classifying Daylight for Design. *International Journal of Architectural Computing* 1(2), pp. 205–217. Available at: <http://papers.cumincad.org/data/works/att/ijac20031206.content.pdf> [Accessed: 29 January 2019].
- Glenn, M. 2012. *El Croquis*.

References

Goriet, M., Monfardini, G. and Scarselli, F. 2005. A new model for learning in graph domains. *Proceedings of the International Joint Conference on Neural Networks 2*, pp. 729–734. doi: 10.1109/IJCNN.2005.1555942.

Gray, D.E. (David E. 2014. *Doing research in the real world*. 3rd ed. London: SAGE.

Greene, J.C., Benjamin, L. and Goodyear, L. 2001. The Merits of Mixing Methods in Evaluation. *Evaluation* 7(1), pp. 25–44. Available at: <https://doi.org/10.1177/13563890122209504>.

Groat, and Wang, D. 2013. *Architectural Research Methods*. second ed. John Wiley & Sons, Inc. All.

Hall, R.P. and Kibler, D.F. 1985. Differing Methodological Perspectives in Artificial Intelligence Research. *AI Magazine* 6(3), pp. 166–178.

Hamilton, W.L., Ying, R. and Leskovec, J. 2017. Inductive representation learning on large graphs. *Advances in Neural Information Processing Systems 2017-Decem(Nips)*, pp. 1025–1035.

Haralambos, Michael. and Holborn, Martin. 1995. *Sociology*. London: Collins Educational.

Hartigan, J.A. and Wong, M.A. 2001. A K-means Clustering Algorithm. *Applied Statistics* 28, pp. 100–108.

Hazlett, K.E., Figueroa, C.M. and Nielson, K.A. 2015. Executive functioning and risk for Alzheimer's disease in the cognitively intact: Family history predicts Wisconsin Card Sorting Test performance. *Neuropsychology* 29(4), p. 582.

He, C., Fu, H., Guo, C., Luk, W. and Yang, G. 2017. A Fully-Pipelined Hardware Design for Gaussian Mixture Models. *IEEE Transactions on Computers* 66(11), pp. 1837–1850. doi: 10.1109/TC.2017.2712152.

Heitor, T. v., Duarte, J.P. and Pinto, R.M. 2004. Combining Grammars and Space Syntax: Formulating, Generating and Evaluating Designs. *International Journal of Architectural Computing* 2(4), pp. 491–515. doi: 10.1260/1478077042906221.

Hensel, M.U. and Turko, J.P. 2015. *Grounds and envelopes: Reshaping architecture and the built environment*. doi: 10.4324/9781315728117.

Heskett, J. 2005. *Design: A Very Short Introduction*. Oxford: Oxford University Press.

Hillier, B.R. 1972. KNOWLEDGE AND DESIGN. *Environmental Design: Research and Practice* 2, pp. 1–14.

Holl, S. 1988. Within the City: Phenomena of Relations. *Design Quarterly* (139), pp. 1–30. Available at: <http://www.jstor.org/stable/4091209>.

Holl, Steven. 2007. *House: black swan theory*. New York: Princeton Architectural Press. Available at: <http://public.eblib.com/choice/publicfullrecord.aspx?p=3387431>.

Hu, W.E.I. 2021. THE EXPERIMENT OF NEURAL NETWORK ON THE COGNITION OF STYLE., pp. 61–70.

References

Huang, W. and Zheng, H. 2018. Architectural drawings recognition and generation through machine learning. *Recalibration on Imprecision and Infidelity - Proceedings of the 38th Annual Conference of the Association for Computer Aided Design in Architecture, ACADIA 2018*, pp. 156–165. Available at: <https://www.scopus.com/inward/record.uri?eid=2-s2.0-85060372020&partnerID=40&md5=2fa5fecb30a89d016f9537579267c3fa>.

Hudson, R. 2010. Strategies for Parametric Design in Architecture: An application of practice led research - Opus. Available at: <http://opus.bath.ac.uk/20947/>.

Hulin, W.S. and Katz, D. 1935. The Frois-Wittmann pictures of facial expression. *Journal of Experimental Psychology* 18(4), pp. 482–498. doi: 10.1037/h0056770.

Isaac, S. and Michael, W.B. 1995. *Handbook in research and evaluation: A collection of principles, methods, and strategies useful in the planning, design, and evaluation of studies in education and the behavioral sciences*. Edits publishers.

Jabi, W. 2013. Parametric Design for Architecture. In: *International Journal of Architectural Computing*. London : Laurence King Publishing, pp. 465–468. Available at: <http://multi-science.metapress.com/index/4HUK11NQ615VQ311.pdf> [Accessed: 17 October 2018].

Jabi, W. 2015. *The potential of non-manifold topology in the early design stages*. Available at: http://papers.cumincad.org/data/works/att/acadia15_381.pdf [Accessed: 19 December 2018].

Jabi, W. 2016. Linking design and simulation using non-manifold topology. *Architectural Science Review* 59(4), pp. 323–334. Available at: <https://doi.org/10.1080/00038628.2015.1117959>.

Jabi, W. and Aish, R. 2018. Non-manifold Topology for Architectural and Engineering Modelling. *eCAADe Workshops: Computing for a better tomorrow* 1, pp. 57–60.

Jabi, W., Aish, R., Lannon, S., Chatzivasileiadi, A. and Wardhana, N.M. 2018. Topologic A toolkit for spatial and topological modelling. In: *SHAPE, FORM & GEOMETRY*. Available at: http://papers.cumincad.org/data/works/att/ecaade2018_310.pdf [Accessed: 19 December 2018].

Jabi, W., Chatzivasileiadi, A., Wardhana, N.M., Lannon, S. and Aish, R. 2019. The synergy of non-manifold topology and reinforcement learning for fire egress. *Proceedings of the International Conference on Education and Research in Computer Aided Architectural Design in Europe 2*, pp. 85–94. doi: 10.5151/proceedings-ecaadesigradi2019_671.

Jabi, W., Soe, S., Theobald, P., Aish, R. and Lannon, S. 2017. Enhancing parametric design through non-manifold topology. *Design Studies* 52, pp. 96–114. Available at: <http://dx.doi.org/10.1016/j.destud.2017.04.003>.

Jain, A.K. and Dubes, R.C. 1988. *Algorithms for Clustering Data*. Prentice-Hll, Inc.

Jeffries, R., Miller, J.R., Wharton, C. and Uyeda, K.M. 1991. User interface evaluation in the real world: A comparison of four techniques. *Conference on Human Factors in Computing Systems - Proceedings* 91(c), pp. 119–124. doi: 10.1145/108844.108862.

Johansson, R. 2003. Case Study Methodology. In: *International Conference "Methodologies in Housing Research."*, pp. 60–82. doi: 10.4018/978-1-5225-9429-1.ch004.

References

- Johnson, R.B. and Onwuegbuzie, A.J. 2007. Toward a Definition of Mixed Methods Research. *Journal of Mixed Methods Research* 1(2), pp. 112–133. doi: 10.1177/1558689806298224.
- Joroff, M.L., Morse, S.J., Technology., M.I. of and Planning., L. of A. and 1983. *A proposed framework for the emerging field of architectural research*. [Cambridge, Mass.]: Laboratory of Architecture and Planning, Massachusetts Institute of Technology.
- Jumelet, D. 2013. Jumelet, D. (2013). Architecture Levels of Abstraction and Detail: How to Make Those Work for You.
- Kheiri, F., Daneshpoor, A. and Khanmohammadi, M. 2013. A Comparison of Different Paradigms of Architectural Design Process: Unconsciousness, Consciousness, Hyperconscious.
- Kim, J.I.N.S., Song, J.A.E.Y. and Lee, J.I.N.K. 2018. APPROACH TO THE EXTRACTION OF DESIGN FEATURES OF INTERIOR DESIGN ELEMENTS USING IMAGE RECOGNITION TECHNIQUE., pp. 287–296.
- Kincheloe, J.L. and Tobin, K. 2009. The much exaggerated death of positivism. *Cultural Studies of Science Education* 4(3), pp. 513–528. doi: 10.1007/s11422-009-9178-5.
- Kipf, T.N. and Welling, M. 2017. Semi-supervised classification with graph convolutional networks. *5th International Conference on Learning Representations, ICLR 2017 - Conference Track Proceedings* , pp. 1–14.
- Kipnis, Jeffrey. 2013. *A Question of Qualities: Essays in Architecture*. Available at: https://www.amazon.com/Question-Qualities-Essays-Architecture-Writing/dp/0262519550/ref=sr_1_70?s=books&ie=UTF8&qid=1472298162&sr=1-70&keywords=architecture+philosophy [Accessed: 30 January 2019].
- Kitchley, J.J.L. and Srivathsan, A. 2014. Generative methods and the design process: A design tool for conceptual settlement planning. *Applied Soft Computing Journal* 14(PART C), pp. 634–652. doi: 10.1016/j.asoc.2013.08.017.
- K.Norman, D. and Lincoln, Y.S. 2000. Handbook of Qualitative Research., p. 1144.
- Kothari, C.R. 2004. *Research Methodology, Methods and Techniques*.
- Krish, S. 2011. A practical generative design method. *Computer aided design* 43(1), pp. 88–100.
- Kuma, K. 2005. *GA Architect 19 MINT*. ADA Editors, Japan.
- Kuma, K. 2008. *Anti-object : the dissolution and disintegration of architecture*. Architectural Association.
- Kumar, R. 2014. *Research methodology : a step-by-step guide for beginners*. Fourth edi.
- Kumar, R. 2019. *Research methodology : a step-by-step guide for beginners*. Fifth edit. Los Angeles .
- Lakshmi, L. 2019. Graph theory and architecture. (December)

References

Leatherbarrow, David. 2000. *Uncommon ground : architecture, technology, and topography / David Leatherbarrow*. Cambridge Mass.;;London: MIT Press. Available at: <https://www.worldcat.org/search?q=isbn%3A9780262122306> [Accessed: 1 January 2019].

Leatherbarrow, David. 2004. *Topographical Stories: Studies in Landscape and Architecture*. Philadelphia : University of Pennsylvania Press.

Lee, J., Gu, N. and Williams, A. 2014. Parametric design strategies for the generation of creative designs. *International Journal of Architectural Computing* 12(3), pp. 263–282. doi: 10.1260/1478-0771.12.3.263.

Lee, J.H. and Lee, J.-H. 2016a. Cultural Difference in Colour Usages for Building Facades focusing on Theme Park Buildings. In: *Living Systems and Micro-Utopias: Towards Continuous Designing: Proceedings of the 21st International Conference of CAADRIA.*, pp. 621–630. Available at: http://papers.cumincad.org/data/works/att/caadria2016_621.pdf [Accessed: 21 February 2019].

Lee, J.H. and Lee, J.-H. 2016b. Cultural Difference in Colour Usages for Building Facades focusing on Theme Park Buildings. In: *Living Systems and Micro-Utopias: Towards Continuous Designing: Proceedings of the 21st International Conference of CAADRIA.*, pp. 621–630. Available at: http://papers.cumincad.org/data/works/att/caadria2016_621.pdf [Accessed: 21 February 2019].

Lee, S.U., Roh, M. il, Cha, J.H. and Lee, K.Y. 2009. Ship compartment modeling based on a non-manifold polyhedron modeling kernel. *Advances in Engineering Software* 40(5), pp. 378–388. Available at: <http://dx.doi.org/10.1016/j.advengsoft.2007.12.001>.

Levie, R., Monti, F., Bresson, X. and Bronstein, M.M. 2018. CayleyNets: Graph Convolutional Neural Networks with Complex Rational Spectral Filters. *IEEE Transactions on Signal Processing* 67(1), pp. 97–109. doi: 10.1109/TSP.2018.2879624.

Li, A.I. 2001. A shape grammar for teaching the architectural style of the Yingzao fashi. *Thesis (Ph. D.)--Massachusetts Institute of Technology, Dept. of Architecture*, 1

Lin, C.J. 2013. Visual architectural topology: An ontology-based topological tool for use in an architectural case library. *Computer-Aided Design and Applications* 10(6), pp. 929–937. doi: 10.3722/cadaps.2013.929-937.

Lu, Y., Tian, R., Li, A., Wang, X. and del Castillo Lopez Jose Luis, G. 2021. CUBIGRAPH5K: Organizational graph generation for structured architectural floor plan dataset. *Projections - Proceedings of the 26th International Conference of the Association for Computer-Aided Architectural Design Research in Asia, CAADRIA 2021* 1, pp. 81–90.

Lucas, R. 2016. *Research Methods for Architecture*. doi: 10.1080/24751448.2017.1292802.

Ma, L., Sacks, R., Kattel, U. and Bloch, T. 2018. 3D Object Classification Using Geometric Features and Pairwise Relationships. *Computer-Aided Civil and Infrastructure Engineering* 33(2), pp. 152–164. doi: 10.1111/mice.12336.

Maani, D.O. 2014. Notes on Architectural Design. 26(Kockabiyik 2004), pp. 57–68.

van der Maaten, L. and Hinton, G. 2008. Visualizing data using t-SNE. *Journal of Machine Learning Research* 9, pp. 2579–2625.

References

- Mack, L. 2010. The Philosophical Underpinnings of Educational Research. *Polyglossia* , pp. 5–11. Available at: http://www.apu.ac.jp/rcaps/uploads/fckeditor/publications/polyglossia/Polyglossia_V19_Lindsay.pdf.
- Mahmoodi, A.S. 2001. The design process in architecture: a pedagogic approach using interactive thinking. (September), p. 353. Available at: http://etheses.whiterose.ac.uk/2155/1/uk_bl_ethos_543080.pdf.
- Masadeh, M. and Masadeh, M.A. 2012. Focus Group: Reviews and Practices The Influence of Employee Empowerment on Employee Job Satisfaction in Five-Star Hotels in Jordan View project Focus Group: Reviews and Practices. *International Journal of Applied Science and Technology* 2(10)
- Mastenbroek, B., Mecredy, E., Baan, I. 1975- and (Firm), S. 2021. *Dig it! : Building bound to the ground*. Köln SE - 1390 pages : illustrations (chiefly color), charts, maps, plans, portraits ; 27 cm: Taschen.
- Masuda, H. 1993. Topological operators and Boolean operations for complex-based nonmanifold geometric models. *Computer-Aided Design* 25(2), pp. 119–129. doi: 10.1016/0010-4485(93)90097-8.
- Minsky, M. 1961. Steps Toward Artificial Intelligence. *Proceedings of the IRE* 49(1), pp. 8–30. doi: 10.1109/JRPROC.1961.287775.
- Mitchell, T. 1997. *Machine Learning*.
- Morente-Molinera, J.A., Ríos-Aguilar, S., González-Crespo, R. and Herrera-Viedma, E. 2019. Dealing with group decision-making environments that have a high amount of alternatives using card-sorting techniques. *Expert Systems with Applications* 127, pp. 187–198. doi: 10.1016/j.eswa.2019.03.023.
- Mukherji, P. and Albon, D. 2018. *Research methods in early childhood: An introductory guide*. Sage.
- Naoum, S.G. 2012. *Dissertation research and writing for construction students*. Routledge.
- mac Naughton, G., Rolfe, S.A. and Siraj-Blatchford, I. 2001. *Doing early childhood research: International perspectives on theory and practice*. Maidenhead, BRK, England: Open University Press.
- Neuman, W.L. and Robson, K. 2014. *Basics of social research*. Pearson Canada Toronto.
- Newman, O. 1972. *Defensible space : crime prevention through urban design*. New York: Macmillan.
- Ng, J.M.Y., Khean, N., Madden, D., Fabbri, A., Gardner, N., Haeusler, M.H. and Zavoleas, Y. 2019. Optimising image classification implementation of convolutional neural network algorithms to distinguish between plans and sections within the architectural, engineering and construction (AEC) industry. *Intelligent and Informed - Proceedings of the 24th International Conference on Computer-Aided Architectural Design Research in Asia, CAADRRIA 2019 2*, pp. 795–804.

References

Nguyen, T.D. 2011. Simplifying the Non-Manifold Topology of Multi-Partitioning Surface Networks. *Department of Computer Science & Engineering Master of*

Nielsen, J. 1994. Usability inspection methods. *Conference on Human Factors in Computing Systems - Proceedings 1994-April*, pp. 413–414. doi: 10.1145/259963.260531.

Niepert, M., Ahmad, M. and Kutzkov, K. 2016. Learning convolutional neural networks for graphs. *33rd International Conference on Machine Learning, ICML 2016 4*, pp. 2958–2967.

Nirosh.L 2021. Introduction to Object Oriented Programming Concepts (OOP) and More. Available at: <http://www.codeproject.com/Articles/22769/Introduction-to-Object-Oriented-%0DProgramming-Concept> [Accessed: 15 August 2022].

Obeso, A.M., Benois-Pineau, J., Acosta, A.Á.R. and Vázquez, M.S.G. 2016. Architectural style classification of Mexican historical buildings using deep convolutional neural networks and sparse features. *Journal of Electronic Imaging* 26(1), p. 011016. doi: 10.1117/1.jei.26.1.011016.

Onwuegbuzie, A.J. and Leech, N.L. 2007. Sampling designs in qualitative research: Making the sampling process more public. *Qualitative Report* 12(2), pp. 238–254.

Oxman, R. and Gu, N. 2015. Theories and Models of Parametric Design Thinking. *Proceedings of the International Conference on Education and Research in Computer Aided Architectural Design in Europe 2*, pp. 477–482. doi: 10.52842/conf.ecaade.2015.2.477.

Pan, Z., Yu, W., Yi, X., Khan, A., Yuan, F. and Zheng, Y. 2019. Recent Progress on Generative Adversarial Networks (GANs): A Survey. *IEEE Access* 7, pp. 36322–36333. doi: 10.1109/ACCESS.2019.2905015.

Park, K.S. and Hwan Lim, C. 1999. A structured methodology for comparative evaluation of user interface designs using usability criteria and measures. *International Journal of Industrial Ergonomics* 23(5–6), pp. 379–389. doi: 10.1016/S0169-8141(97)00059-0.

Paryudi, I. and Fenz, S. 2013. Friendly User Interface Design For Architects In An Energy Simulation Tool. *International Journal of Scientific & Technology Research* 2(11), pp. 203–208.

Pedregosa Fabian et al. 2011. Scikit-learn: Machine Learning in Python Gaël Varoquaux Bertrand Thirion Vincent Dubourg Alexandre Passos PEDREGOSA, VAROQUAUX, GRAMFORT ET AL. Matthieu Perrot. *Journal of Machine Learning Research* 12, pp. 2825–2830. Available at: <http://scikit-learn.sourceforge.net>. [Accessed: 5 March 2019].

Peponis, J., Lycourioti, I. and Mari, I. 2002. Spatial Models Design Reasons and the Construction of Spatial Meaning. *Philosophica* 70

Philbin, J., Chum, O., Isard, M., Sivic, J. and Zisserman, A. 2007. Object retrieval with large vocabularies and fast spatial matching. *Proceedings of the IEEE Computer Society Conference on Computer Vision and Pattern Recognition* . doi: 10.1109/CVPR.2007.383172.

Popper, K.R. 1962. CONJECTURES AND REFUTATIONS. *Manufactured in the United States of America* |

Della Porta, D. and Keating, M. 2008. Approaches and Methodologies in the Social Sciences. *Approaches and methodologies in the social sciences* , p. 316.

References

- Porter, Z.T. 2015. Contested Terrain. *Chapter Title (ACSA will complete)* , pp. 1–6.
- Porter, Z.T. 2016. Lecture Note, CS2496.
- Porter, Z.T. 2017. Architecture ≠ Landscape: The Case Against Hybridization. Available at: https://www.academia.edu/36278512/Architecture_Landscape_The_Case_Against_Hybridization [Accessed: 14 December 2018].
- Punch, K.F. and Oancea, A. 2014. *Introduction to research methods in education*. Sage.
- Rafique, D. and Velasco, L. 2018. Machine Learning for Network Automation: Overview, Architecture, and Applications [Invited Tutorial]. *Journal of Optical Communications and Networking* 10(10), p. 18. Available at: <https://www.osapublishing.org/abstract.cfm?URI=jocn-10-10-D126>.
- Rajchman, J. 2000. *Constructions*. Cambridge, Mass: MIT Press.
- Reddy, Y.C.A.P., Viswanath, P. and Reddy, B.E. 2018. Semi - supervised learning : a brief review. *International Journal of Engineering & Technology* 7, pp. 81–85.
- Riley, Terence. and Reed, Peter. 1994. *Frank Lloyd Wright: architect*. New York; New York: The Museum of Modern Art ; Distributed by Abrams.
- Robinson, L.J., Gray, J.M., Ferrier, I.N. and Gallagher, P. 2016. The effect of self-monitoring on Wisconsin Card Sorting Test performance in euthymic patients with bipolar disorder: a pilot study. *Cognitive Neuropsychiatry* 21(3), pp. 256–270. Available at: <http://dx.doi.org/10.1080/13546805.2016.1184134>.
- Robson, C. 2002. *Real world research : a resource for social scientists and practitioner-researchers*. 2nd ed. Oxford: Blackwell Publishers.
- de Roure, D. and Willcox, P. 2017. Experimental humanities: An adventure with lovelace and babbage. *Proceedings - 13th IEEE International Conference on eScience, eScience 2017* , pp. 194–201. doi: 10.1109/eScience.2017.32.
- Ruch, J., Owings, S. and Merrill 1978. Interactive space layout: A Graph theoretical approach. *Proceedings - Design Automation Conference* , pp. 152–157. doi: 10.1109/DAC.1978.1585162.
- Ruff, Thomas. 1995. *Architectures of Herzog & de Meuron*. New York: Peter Blum.
- Rugg, G. and McGeorge, P. 2005. A rticle picture sorts and item sorts. *Expert Systems* 22(3), pp. 94–107.
- Said, S. and Embi, M.R. 2008. A Parametric Shape Grammar of the Traditional Malay Long-Roof Type Houses. *International Journal of Architectural Computing* 6(2), pp. 121–144. doi: 10.1260/147807708785850113.
- Samuel, A.L. 1959. Some studies in machine learning using the game of checkers. *IBM Journal of Research and Development* 44(1.2), pp. 206–226. Available at: <http://ieeexplore.ieee.org/document/5389202/>.
- Sanders, J. 2011. HUMAN / NATURE : WILDERNESS AND THE LANDSCAPE / ARCHITECTURE DIVIDE (The Monacelli Press). In: *Groundwork: Between Landscape and Architecture*.

References

Sasmito, G.W., Zulfiqar, L.O.M. and Nishom, M. 2019. Usability Testing based on System Usability Scale and Net Promoter Score. *2019 2nd International Seminar on Research of Information Technology and Intelligent Systems, ISRITI 2019* , pp. 540–545. doi: 10.1109/ISRITI48646.2019.9034666.

Saunders, M., Lewis, P. and Thornhill, A. 2007. Research methods. *Business Students 4th edition Pearson Education Limited, England*

Sauro, Jeff. 2011. *A practical guide to the system usability scale : background, benchmarks & best practices*. Denver, Colo: Measuring Usability LCC.

Scarselli, F., Gori, M., Tsoi, A.C., Hagenbuchner, M. and Monfardini, G. 2009. The graph neural network model. *IEEE Transactions on Neural Networks* 20(1), pp. 61–80. doi: 10.1109/TNN.2008.2005605.

Schindler, R.M., Smith, E.A.T., Darling, Michael., Museum of Contemporary Art (Los Angeles, Calif.), (U.S.), N.B.M. and Kunst., O.M. für A. 2001. *The architecture of R.M. Schindler*. Los Angeles, Calif.; New York: Museum of Contemporary Art, Los Angeles ; in association with Harry N. Abrams.

Schmidhuber, J. 2015. Deep Learning in neural networks: An overview. *Neural Networks* 61, pp. 85–117. Available at: <http://dx.doi.org/10.1016/j.neunet.2014.09.003>.

Seelow, A. 2018. The Construction Kit and the Assembly Line—Walter Gropius' Concepts for Rationalizing Architecture. *Arts* 7(4), p. 95. doi: 10.3390/arts7040095.

Segers, N., Vries, B., Achten, H. and Timmermans, H. 2001. Towards computer-aided support of associative reasoning in the early phase of architectural design. *CAADRIA* (July), pp. 95–98.

Serra Fernandes, R.M. 2013. Generative Design : a new stage in the design process. (June), p. 132. Available at: <https://www.google.com.gh/url?sa=t&rct=j&q=&esrc=s&source=web&cd=2&cad=rja&uact=8&ved=0ahUKEwujwuqa-orUAhVrC8AKHWnhBrsQFggwMAE&url=https%3A%2F%2Fwww.scribd.com%2Fdocument%2F283766905%2FGenerative-Design-Generative-Design-a-new-stage-in-the-design-procesa->

Shalunts, G. 2012. Architectural Style Classification of Building Facade Towers. *Advances in Visual Computing* 7432, pp. 346–357. Available at: http://link.springer.com/chapter/10.1007/978-3-642-33191-6_34%5Cnhttp://www.springerlink.com/index/10.1007/978-3-642-33191-6.

Shalunts, G., Haxhimusa, Y. and Sablatnig, R. 2012. Classification of gothic and baroque architectural elements. *2012 19th International Conference on Systems, Signals and Image Processing, IWSSIP 2012* (April), pp. 316–319.

Shalunts, Gayane, Yll Haxhimusa, R.S. 2011. Architectural Style Classification of Building Facade Windows. *Lecture Notes in Computer Science (including subseries Lecture Notes in Artificial Intelligence and Lecture Notes in Bioinformatics)* 9474, pp. 285–294. doi: 10.1007/978-3-319-27857-5_26.

Sharma, N., Bajpai, A. and Litoriya, R. 2012. Comparison the various clustering algorithms of weka tools. *International Journal of Emerging Technology and Advanced Engineering* 2(5), pp. 73–80.

References

Shekhawat, K., Pinki and Duarte, J.P. 2019. A Graph Theoretical Approach for Creating Building Floor Plans. *Communications in Computer and Information Science* 1028, pp. 3–14. doi: 10.1007/978-981-13-8410-3_1.

Sherif, M. and Sherif, C.W. 1967. *Problems of youth : transition to adulthood in a changing world, edited by Muzafer Sherif and Carolyn W. Sherif*. Chicago: Aldine Pub. Co.

Silvestre, J. 2016. Edition-oriented 3d model rebuilt from photography., pp. 445–454.

Silvestre, J., IKEDA, Y.I. and GUÉNA, F. 2016. ARTIFICIAL IMAGINATION OF ARCHITECTURE WITH DEEP CONVOLUTIONAL NEURAL NETWORK " Laissez-faire " : loss of control in the esquisse phase., pp. 881–890. Available at: http://papers.cumincad.org/data/works/att/caadria2016_881.pdf.

Smith, J.K. 1983. Quantitative versus qualitative research: An attempt to clarify the issue. *Educational researcher* 12(3), pp. 6–13.

Snozzi, L., Disch, Peter., Siza, A., Diener, Roger. and Croset, P.-Alain. 1995. *Luigi Snozzi : costruzioni e progetti 1958-1993 = buildings and projects 1958-1993*. ADV Pub. House. Available at: https://whel-primo.hosted.exlibrisgroup.com/primo-explore/fulldisplay?docid=44CAR_ALMA2161703220002420&context=L&vid=44WHELFCAR_VU1&lang=en_US&search_scope=CSCOP_EVERYTHING&adaptor=Local Search Engine&tab=searchall@cardiff&query=any,contains,Snozzi,luigi [Accessed: 18 November 2018].

Sperduti, A. and Starita, A. 1997. Supervised neural networks for the classification of structures. *IEEE transactions on neural networks* 8(3), pp. 714–735. doi: 10.1109/72.572108.

Stasiuk, D. and Thomsen, M.R. 2014. Learning to be a Vault - Implementing learning strategies for design exploration in inter-scalar systems. *Fusion, Proceedings of the 32nd International Conference on Education and research in Computer Aided Architectural Design in Europe 1*, pp. 381–390. Available at: <http://cita.karch.dk/> [Accessed: 29 January 2019].

Stiny, G. 1980a. Kindergarten grammars: designing with Froebel's building gifts. *Environment and Planning B: Planning and Design* 7(4), pp. 409–462. doi: 10.1068/b070409.

Stiny, G. 2006. *Shape : talking about seeing and doing*. Cambridge, Mass. ; London: MIT.

Stiny, G. and Mitchell, W.J. 1978. The Palladian grammar. *Environment and Planning B: Planning and Design* 5(1), pp. 5–18. doi: 10.1068/b050005.

Stiny, G.N. 1980b. Introduction to shape grammars. *ACM SIGGRAPH 2008 Classes* 7(November), p. 36. doi: 10.1145/1401132.1401182.

Stiny, G.N. and Gips, J. 1972. Shape Grammars and the Generative Specification of Painting and Sculpture," *Information Processing 71, IFIP, North-Holland, Amsterdam. Information Processing* 71, pp. 125–135. Available at: http://scholar.google.com/scholar?q=related:KltbNKT-FrkJ:scholar.google.com/&hl=en&num=20&as_sdt=0,5%5Cnpapers3://publication/uuid/167EBFAC-F37B-43EF-B5C6-0891B1EA9B1E.

References

Stouffs, R. 2015. Description grammars: An overview. *CAADRIA 2015 - 20th International Conference on Computer-Aided Architectural Design Research in Asia: Emerging Experiences in the Past, Present and Future of Digital Architecture* (August), pp. 137–146.

Sun, F.-Y., Hoffmann, J., Verma, V. and Tang, J. 2020. InfoGraph: Unsupervised and Semi-supervised Graph-Level Representation Learning via Mutual Information Maximization. *ICLR 2020* (2019), pp. 1–22. Available at: <http://arxiv.org/abs/1908.01000>.

Suter, W. 2014. *Qualitative Data, Analysis, and Design*. doi: 10.4135/9781483384443.n12.

T. Wiscombe 2014. Discreteness, or Towards a Flat Ontology of Architecture. *PROJECT* (3), p. 108. Available at: <http://projectjournal.org/product/project-issue-three-spring-2013/> [Accessed: 21 January 2019].

Tamke, M. 2015. Assessing implicit knowledge in BIM models with machine learning. *Modelling Behaviour* (December). doi: 10.1007/978-3-319-24208-8.

Tamke, M., Zwierzycki, M., Evers, H.L., Ochmann, S., Vock, R. and Wessel, R. 2016. Tracking Changes in Buildings over Time - Fully Automated Reconstruction and Difference Detection of 3d Scan and BIM files. *34th eCAADe Conference 2*, pp. 643–651. Available at: http://papers.cumincad.org/cgi-bin/works/Show?ecaade2016_147.

Teddlie, C. and Tashakkori, A. 2009. *Foundations of mixed methods research: Integrating quantitative and qualitative approaches in the social and behavioral sciences*. Sage.

Terzidis, C. 1994. Computer-aided Extraction of Morphological Information from Architectural Drawings. *ACADIA*, pp. 77–86.

Thau, Carsten. and Vindum, Kjeld. 2001. *Arne Jacobsen*. Copenhagen: Arkitektens Forlag.

Thombre, P. 2018. Multi-objective path finding using reinforcement learning., p. 52. Available at: https://scholarworks.sjsu.edu/cgi/viewcontent.cgi?article=1632&context=etd_projects.

Torus, B. 2012. Charles correa's housing language. *Archi-Cultural Translations through the Slik Road, 2nd International Conference*, pp. 207–212.

Trotter, Janet. 1992. *Information technology in initial teacher training : two years after the Trotter Report : September 1989 - April 1991*. [London]: DES.

Tschumi, B. 1990. *Questions of space: lectures on architecture*. Bernard Tschumi and the Architectural Association. Available at: https://whel-primo.hosted.exlibrisgroup.com/primo-explore/fulldisplay?docid=44CAR_ALMA2153760260002420&context=L&vid=44WHELP_CAR_VU1&lang=en_US&search_scope=CSCOP_EVERYTHING&adaptor=Local Search Engine&tab=searchall@cardiff&query=any,contains,Tschumi,Ques [Accessed: 30 December 2018].

Tullis, T.S. and Stetson, J.N. 2004. A Comparison of Questionnaires for Assessing Website Usability ABSTRACT : Introduction. *Usability Professional Association Conference*, pp. 1–12.

Upasani, N., Shekhawat, K. and Sachdeva, G. 2020. Automated generation of dimensioned rectangular floorplans. *Automation in Construction* 113. doi: 10.1016/j.autcon.2020.103149.

References

Uzun, C. and Çolakoğlu, M.B. 2019. Architectural Drawing Recognition A case study for training the learning algorithm with architectural plan and section drawing images. *Proceedings of the International Conference on Education and Research in Computer Aided Architectural Design in Europe 2*(December), pp. 29–34. doi: 10.5151/proceedings-ecaadesigradi2019_171.

Uzun, C., Çolakoğlu, M.B. and İnceoğlu, A. 2020. GAN as a generative architectural plan layout tool: A case study for training DCGAN with palladian plans and evaluation of DCGAN outputs. *A/Z ITU Journal of the Faculty of Architecture* 17(2), pp. 185–198. doi: 10.5505/itujfa.2020.54037.

Wagner, K. 2016. The Modularity is Here: A Modern History of Modular Mass Housing Schemes. *99% Invisible*

Wahyuni, D. 2012. The research design maze: Understanding paradigms, cases, methods and methodologies. (June 2012)

Wang, H., Ma, C. and Zhou, L. 2009. A brief review of machine learning and its application. *Proceedings - 2009 International Conference on Information Engineering and Computer Science, ICIECS 2009*, pp. 1–4. doi: 10.1109/ICIECS.2009.5362936.

Wang, Y. and Duarte, J.P. 2001. Automatic generation and fabrication of designs. *Automation in Construction* 11(3), pp. 291–302. doi: 10.1016/S0926-5805(00)00112-6.

Wang, Z., Sacks, R. and Yeung, T. 2022. Exploring graph neural networks for semantic enrichment: Room type classification. *Automation in Construction* 134(October 2021), p. 104039. Available at: <https://doi.org/10.1016/j.autcon.2021.104039>.

Weller, S.C. and Romney, A.K. 1988. *Systematic data collection*. Newbury Park: Sage.

Weston, R. 1995. *Alvar Aalto*. London: Phaidon Press.

Woodbury, R. (Robert F. 2010. *Elements of parametric design*. London ;;New York: Routledge. Available at: https://www.worldcat.org/title/elements-of-parametric-design/oclc/916484801&referer=brief_results [Accessed: 17 October 2018].

Wright, F.L. 1955. *An American architecture*. New York: Horizon Press. Available at: <https://www.worldcat.org/search?q=no%3A271207> [Accessed: 30 December 2018].

Wright, F.L. 1975. in the Cause of Architecture. *New York: Architectural record.*, pp. 44–129. doi: 10.1016/b978-0-85139-352-0.50007-5.

Wu, Z., Pan, S., Chen, F., Long, G., Zhang, C. and Yu, P.S. 2019. A Comprehensive Survey on Graph Neural Networks. XX(Xx), pp. 1–22.

Xiao, Y., Chen, S., Ikeda, Y. and Hotta, K. 2020. Automatic recognition and segmentation of architectural elements from 2D drawings by convolutional neural network. *RE: Anthropocene, Design in the Age of Humans - Proceedings of the 25th International Conference on Computer-Aided Architectural Design Research in Asia, CAADRIA 2020 1*, pp. 843–852.

Xie, T. and Grossman, J.C. 2018. Crystal Graph Convolutional Neural Networks for an Accurate and Interpretable Prediction of Material Properties. *Physical Review Letters* 120(14). doi: 10.1103/PhysRevLett.120.145301.

References

Xu, Z., Tao, D., Zhang, Y., Wu, J. and Tsoi, A.C. 2014. Architectural style classification using multinomial latent logistic regression. *Lecture Notes in Computer Science (including subseries Lecture Notes in Artificial Intelligence and Lecture Notes in Bioinformatics)* 8689 LNCS(PART 1), pp. 600–615. doi: 10.1007/978-3-319-10590-1_39.

Yambem, N. and Nandakumar, A.N. 2016. A Technical Insight into Clustering Algorithms & Applications. *International Research Journal of Engineering and Technology (IRJET)* 3, pp. 529–533.

Yan, X., Ai, T., Yang, M., Tong, X. and Liu, Q. 2020. A graph deep learning approach for urban building grouping. *Geocarto International* 0(0), pp. 1–24. Available at: <https://doi.org/10.1080/10106049.2020.1856195>.

Yellowbrick 2016. Yellowbrick: Machine Learning Visualization. Available at: <https://www.scikit-yb.org/en/latest/api/cluster/elbow.html> [Accessed: 17 March 2020].

Yoshimura, Y., Cai, B., Wang, Z. and Ratti, C. 2019. Deep learning architect: Classification for architectural design through the eye of artificial intelligence. *Lecture Notes in Geoinformation and Cartography*, pp. 249–265. doi: 10.1007/978-3-030-19424-6_14.

Yousif, S. and Yan, W. 2018. CLUSTERING FORMS FOR ENHANCING ARCHITECTURAL DESIGN OPTIMIZATION. In: *Proceedings of the 23rd International Conference of the Association for Computer-Aided Architectural Design Research in Asia (CAADRIA)*. Available at: http://papers.cumincad.org/data/works/att/caadria2018_257.pdf [Accessed: 28 January 2019].

Yüksel, E. 2014. Architect's Role in Parametric Design. *Explore Lab Research Thesis. Delft: TU Delft, the Netherlands*

Yvonne Feilzer, M. 2010. Doing mixed methods research pragmatically: Implications for the rediscovery of pragmatism as a research paradigm. *Journal of mixed methods research* 4(1), pp. 6–16.

Zeisel, John. 2006. *Inquiry by design : environment/behavior/neuroscience in architecture, interiors, landscape, and planning* LK - <https://mountolivecollege.on.worldcat.org/oclc/60839489>. Rev. ed. New York SE - 400 pages : illustrations, maps ; 24 cm: W.W. Norton & Company.

Zhang, M., Cui, Z., Neumann, M. and Chen, Y. 2018. An end-to-end deep learning architecture for graph classification. *32nd AAAI Conference on Artificial Intelligence, AAAI 2018*, pp. 4438–4445.

APPENDIX

Appendix: I
The Interview Guide with Architects



Introduction

My name is Abdulrahman Alymani, and I am a PhD student at Cardiff University, UK, under the supervision of Dr Wassim Jabi, a Reader in Architectural Computational Methods. We are researching the use of artificial intelligence machine learning methods to uncover the relationship between a building and the ground around it.

What is the purpose of this interview?

The building and ground relationship has not been researched fully in the architectural discipline. Therefore, the current research aims to pinpoint related challenges facing architectural practice during the early design stage, to evaluate the building and ground relationship taxonomy, content, and visual appearance. Finally, the research aims to uncover the need for and benefit of introducing a computational design tool that can cluster and classify the building ground relationship.

What will take place in the interview?

The interview contains 17 questions divided into four sections. The interview's semi-structured nature allows it to utilise more questions to facilitate further exploration of the topic. Answers to the interview questions can either be verbal or make use of images to aid explanations. The interview will take between 50 and 60 minutes. Participants can stop the interview at any moment to take a break or finish it another time. Moreover, participants can decline to answer any questions. Additionally, the interview will be video recorded if the subject gives their consent.

Who can take part?

Participation in the interview will be limited to architects with more than 10 years' experience of the building and ground relationship, whether in academic or practical environments. An expert interview is voluntary, and it is the participant's decision whether they take part in the interview or not.

Appendix

What happens to the collected information?

Any information provided will remain private and anonymous. Nobody will be identified in the final report, and no names will be used anywhere else.

How will participants' personal information be used?

All data acquired during the research will be securely stored. No person will be identified in the research project, and the results will remain anonymous. Any identifiable information, such as names and locations, will be removed from the final transcript.

Thank you for reading this information – please ask any questions if you are unsure about what is written here.

What happens next?

If you are happy to be involved in the interview process, please sign the consent form. If you do not wish to be involved, thank you for your time.

Note: This investigation was granted with ethical approval by the School Research Ethics Committee, Welsh School of Architecture.

Researcher Contact Details:
Abdulrahman Alymani PhD.
Welsh School of Architecture
Cardiff University
Bute Building (Level 3)
King Edward VII Ave.
CARDIFF CF10 3NB
Tel: 07305595852
Email: Alymaniala@cardiff.ac.uk



Welsh School of Architecture
Cardiff University
Bute Building
King Edward VII Avenue
Cardiff, CF10 3NB
Wales, UK
Tel: +44 (0)29 087 4430
Fax: +44 (0)29 2087 4623

Consent form

1. I confirm that I have read the information above and have had the opportunity to ask questions regarding the activity and how my information will be used.
2. I understand that my participation in this project will involve completing an interview related to the building and ground relationship. This interview will require approximately 50 minutes of my time.
3. I understand that participation in this study is entirely voluntary and that I can withdraw from the study at any time without giving a reason.
4. I understand that I am free to ask any questions at any time. I am free to withdraw or discuss my concerns with Dr Wassim Jabi.
5. I understand that the information provided by me will be held confidentially, such that only the Principal Investigator and can trace this information back to me individually. The information will be retained for up to 2 years when it will be deleted/destroyed.
6. I understand that I can ask for the information I provide to be deleted/destroyed at any time and, in accordance with the Data Protection Act, I can have access to the information at any time.
7. I agree that the interview will be video recorded so the researcher can go back to review the answers.
8. I agree to take part in the above study.

I, _____ **[PRINT NAME]** consent to participate in the study conducted by Abdulrahman Alymani, Welsh School of Architecture, Cardiff University with the supervision of Dr. *Wassim Jabi*.

Signature: _____



Welsh School of Architecture
Cardiff University
Bute Building
King Edward VII Avenue
Cardiff, CF10 3NB
Wales, UK
Tel: +44 (0)29 087 4430
Fax: +44 (0)29 2087 4623

An interview guide with architects to uncover the building and ground relationship

The following guide outlines the interview structure with architects who have experience of the building and ground relationship. The interview forms part of a study undertaken during a PhD programme and focuses on uncovering the building and ground relationship using an artificial intelligence machine learning approach. The researcher would like to ask you about the building and ground relationship problem in relation to architectural design. Your answers are appreciated, and any information you provide will help raise understanding of the building and ground relationship and the different ways in which buildings interact with the ground around them. The interview will take approximately 50 - 60 minutes. Please do not feel obliged to answer any question you do not wish to. Your responses will be confidential and used only for this research.

Please feel free to add your comments and do not hesitate to ask any questions. Thank you for your time and feedback.

Researcher: **Abdulrahman Alymani**
Email: Alymaniaa@cardiff.ac.uk
Tel (UK): 0044 - 7305595852
Tel (Saudi Ariba) 00966 - 562000743

Supervisor: **Dr. Wassim Jabi, Reader**
Email: jabiw@cardiff.ac.uk
Tel (UK): 0044 - 2920875981

Appendix

Date of Interview: _____ ID: _____

Section (1) General information (approximately five minutes):

This section will highlight the participant's experience and background.

1. What is your profession?

- Academic staff
- Architectural professional

2. How long have you been working in your role?

- Less than five years
- 5 – 9 years
- 10 – 14 years
- 15 – 19 years
- 20 – 24 years
- 25 – 29 years
- 30 years or more

3. Please provide two or three examples of building and ground relationship projects or research in which you have participated:

Appendix

Section (2) Architectural designs for the building and ground relationship (approximately 15 minutes):

This section will explore building and ground designs and how participants feel about this issue, based on their background experience, knowledge, and preferences. This section aims to highlight building and ground relationship challenges facing the architecture practice during the early design stage.

Phase(1) Issues and challenges:

4. What types of ground form part of your designs?
5. What types of ground do you prefer to use in your designs?
6. What issues or challenges require consideration during the first stage of building design on flat or sloped ground?
7. During the first design stage, what design processes do you use when designing a building on the ground?

Phase(2) Historical development:

This timeline represents the development of physical building and ground designs over the last 100 years.

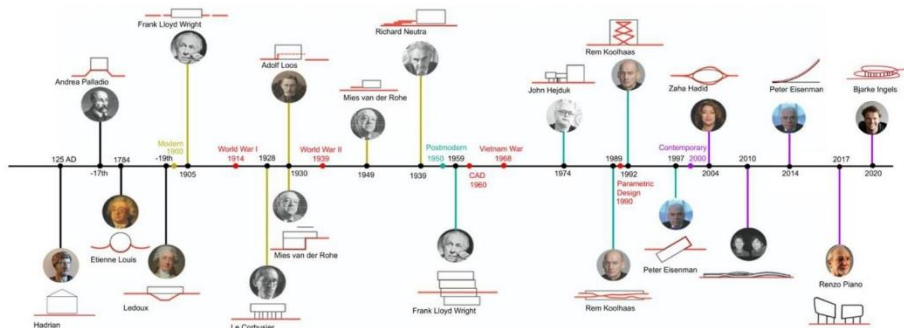

8. Do you think this timeline accurately represents the development of physical building and ground designs? Or do you want to change anything?

Phase(3) Resources:

9. Which of the following do you consider useful resources that help illustrate the building and ground relationship?
 - a) Written academic papers and articles (academic literature)
 - b) Case studies (photographs) of projects/architectural precedents
 - c) Others (please specify)
10. Are you aware of any analytical or generative design tools which can help you design a building in relation to the ground? If yes, can you please specify?

Appendix

Section (3) Building and ground relationship taxonomy (approximately 20 minutes):

This section will focus on validating the building and ground relationship taxonomy collected from the literature review. The section aims to evaluate the created taxonomy content, name or title of the taxonomy and visual appearance.

Phase(1) Taxonomy validation

The following diagram was collected from the literature review to describe the building and ground relationship.

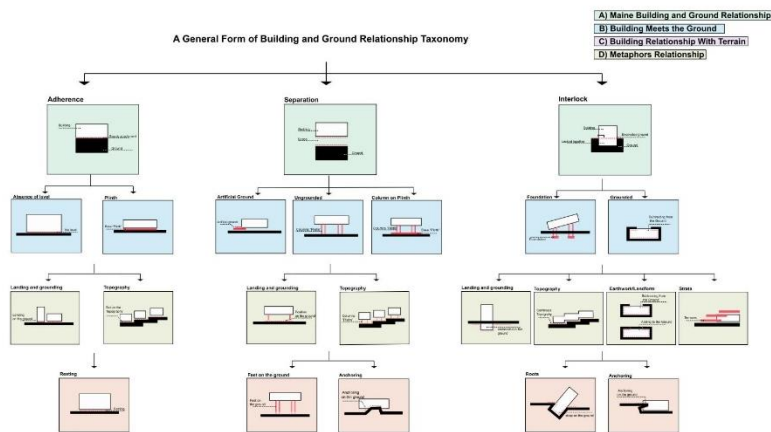

11. Is this taxonomy information useful for architects during the early design stage? Do you want to add or delete? (Feel free to describe by drawing the relationship that requires improvement)

12. How can the previous diagram be improved?

- How can the title and labelling be improved?
- How can the visual diagram be improved? (Feel free to describe by drawing the relationship that requires improvement)

Phase (2) Importance of taxonomy

13. In your opinion, how important is it to have a specific building and ground relationship taxonomy in the early design stage? Why?

Appendix

Section (4) A computational design tool to cluster and classify building and ground relationships (approximately 10 minutes):

This section will focus on exploring the importance of classifying and clustering building and ground relationships. It also aims to uncover the need and benefit of classifying and clustering the computational design.

Phase(1) Importance of the computational design tool

- 14. Do you, as an architect/ academic, think it is important during the early design stage to have a computational tool that can classify and cluster the building and ground precedents into different groups?**
- 15. Why do you think this computational tool is important/not important?**

Phase(2) The computational design tool benefit

- 16. How do you think this building and ground relationship taxonomy will benefit architects and the architectural discipline during the early design stage?**
- 17. Are you happy to see the result of the tool?**

Appendix: II
The Interview Ethical Approval Forms

WELSH SCHOOL OF ARCHITECTURE ETHICS APPROVAL FORM FOR STAFF AND PHD/MPHIL PROJECTS		WS 3		
Tick one box:	<input type="checkbox"/> STAFF	<input checked="" type="checkbox"/> PHD/MPHIL		
Title of project:	Interview with architects to uncover the building and ground relationship			
Name of researcher(s):	Abdulrahman Ahmed Alymani			
Name of principal investigator:	Abdulrahman Ahmed Alymani, under Dr Wassim Jabi supervision.			
Contact e-mail address:	Alymaniala@cardiff.ac.uk			
Date:	10/1/20			
Participants		YES	NO	N/A
Does the research involve participants from any of the following groups?	• Children (under 16 years of age)		√	
	• People with learning difficulties		√	
	• Patients (NHS approval is required)		√	
	• People in custody		√	
	• People engaged in illegal activities		√	
	• Vulnerable elderly people		√	
	• Any other vulnerable group not listed here		√	
• When working with children: I have read the Interim Guidance for Researchers Working with Children and Young People (http://www.cardiff.ac.uk/archi/ethics_committee.php)				√
Consent Procedure		YES	NO	N/A
• Will you describe the research process to participants in advance, so that they are informed about what to expect?		√		
• Will you tell participants that their participation is voluntary?		√		
• Will you tell participants that they may withdraw from the research at any time and for any reason?		√		
• Will you obtain valid consent from participants? (specify how consent will be obtained in Box A) ¹		√		
• Will you give participants the option of omitting questions they do not want to answer?		√		
• If the research is observational, will you ask participants for their consent to being observed?		√		
• If the research involves photography or other audio-visual recording, will you ask participants for their consent to being photographed / recorded and for its use/publication?		√		
Possible Harm to Participants		YES	NO	N/A
• Is there any realistic risk of any participants experiencing either physical or psychological distress or discomfort?			√	
• Is there any realistic risk of any participants experience a detriment to their interests as a result of participation?			√	
Data Protection		YES	NO	N/A
• Will any non-anonymous and/or personalised data be generated or stored?			√	
• If the research involves non-anonymous and/or personalised data, will you:	• gain written consent from the participants	√		
	• allow the participants the option of anonymity for all or part of the information they provide	√		
Health and Safety		YES		
Does the research meet the requirements of the University's Health & Safety policies? (http://www.cf.ac.uk/osheu/index.html)		√		
Research Governance		YES	NO	N/A
Does your study include the use of a drug? You need to contact Research Governance before submission (resqgov@cf.ac.uk)			√	

¹ If any non-anonymous and/or personalised data be generated or stored, *written consent* is required.

Appendix

Does the study involve the collection or use of human tissue? You need to contact the Human Tissue Act team before submission (hta@cf.ac.uk)		√	
---	--	---	--

Prevent Duty	YES	
Has due regard be given to the 'Prevent duty', in particular to prevent anyone being drawn into terrorism? https://www.gov.uk/government/uploads/system/uploads/attachment_data/file/445916/Prevent_Duty_Guidance_For_Higher_Education_England_Wales_.pdf http://www.cardiff.ac.uk/publicinformation/policies-and-procedures/freedom-of-speech	√	

If any of the shaded boxes have been ticked, you must explain in Box A how the ethical issues are addressed. If none of the boxes have been ticked, you must still provide the following information. The list of ethical issues on this form is not exhaustive; if you are aware of any other ethical issues you need to make the SREC aware of them.

Box A The Project (provide all the information listed below in a separate attachment)

An interview guide with architects to uncover the building and ground relationship (attached with this form)

Introduction

My name is Abdulrahman Alymani, and I am a PhD student at Cardiff University, UK, under the supervision of Dr Wassim Jabi, a Reader in Architectural Computational Methods. We are researching the use of artificial intelligence machine learning methods to uncover the building and ground relationship.

What is the purpose of this interview?

The building and ground relationship has been dispersed around the architectural discipline. Therefore, the current research aims to pinpoint related challenges facing the architecture practice during the early design stage, to evaluate the building and ground relationship taxonomy content, title and visual appearance. Finally, the research aims to uncover the need and benefit of clustering and classifying the computational design tool.

What will take place in the interview?

The interview contains 17 questions divided into four sections. The interview's sim-structured nature allows it to utilise more questions to facilitate further exploration of the topic. Answers to the interview questions can either be verbal or make use of images to aid explanations. The interview will take between 50 and 60 minutes. Participants can stop the interview at any moment to take a break or finish it another time. Moreover, participants can decline to answer any questions. Additionally, the interview will be video recorded if the subject gives their consent.

Who can take part?

Appendix

Participation in the interview will be limited to architects with more than 10 years' experience of the building and ground relationship, whether in academic or practical environments. An expert interview is voluntary, and it is the participant's decision whether they take part in the interview or not.

What happens to the collected information?

Any information provided will remain private and anonymous. Nobody will be identified in the final report, and no names will be used anywhere else.

How will participants' personal information be used?

All data acquired during the research will be securely stored. No person will be identified in the research project, and the results will remain anonymous. Any identifiable information, such as names and locations, will be removed from the final transcript.



Thank you for reading this information – please ask any questions if you are unsure about what is written here.

What happens next?

If you are happy to be involved in the interview process, please sign the consent form. If you do not wish to be involved, thank you for your time.

Note: This investigation was granted with ethical approval by the School Research Ethics Committee, Welsh School of Architecture.

Researcher Contact Details:
 Abdulrahman Alymani PhD.
 Welsh School of Architecture
 Cardiff University
 Bute Building (Level 3)
 King Edward VII Ave.
 CARDIFF CF10 3NB
 Tel: 07305595852
 Email: Alymaniana@cardiff.ac.uk

Researcher's declaration (tick as appropriate)			
• I consider this project to have negligible ethical implications (can only be used if none of the grey areas of the checklist have been ticked).	<input checked="" type="checkbox"/>		√
• I consider this project research to have some ethical implications .	<input type="checkbox"/>		
• I consider this project to have significant ethical implications	<input type="checkbox"/>		
Signature  CONFIDENTIAL Researcher or MPhil/PhD student		Name Abdulrahman Alymani	Date 13/1/21
Signature  CONFIDENTIAL Lead investigator or supervisor		Name Dr Wassim Jabi	Date

Appendix

Advice from the School Research Ethics Committee

STATEMENT OF ETHICAL APPROVAL
<p>This project had been considered using agreed Departmental procedures and is now approved</p> <p>Signature <i>abdurahmanalymani</i> CONFIDENTIAL Name Dr Chris Whitman Date 21/01/21</p> <p>Chair, School Research Ethics Committee</p>

Appendix: III
Responses from the
Interviews with Architects

Appendix

Interview # 1

Date of Interview: 26/01/2021 (19:00 pm – 19:55 pm)

Section (One) General information (approximately five minutes):

What is your profession?

- Architectural professional

How long have you been working in your role?

- 10– 14 years

1. Please provide two or three examples of building and ground relationship projects or research in which you have participated?



Section (Two) Architectural designs for the building and ground relationship (approximately 15 minutes):

Phase(1) Issues and challenges:

2. What types of ground form part of your designs?

- Most of the design that I faced is a flat ground.
- The biggest challenging is how to integrate the infrastructure with the ground.

3. What types of ground do you prefer to use in your designs?

- I prefer to work with a flat ground, and I like to miniplate the flat ground.
- Catting and fling the ground allow me to create my ground-level biased on my project criteria.

What issues or challenges require consideration during the first stage of building design on flat or sloped ground?

- On the flat ground, the issue is how to specify the starting point or the reference point of starting the construction and the finishing level.

Appendix

- On the sloping ground, the main issue is how to connect the spaces according to the different height that you have in the sloping ground, so you have to define the relation with these different spaces on this different level. For example, the vertical circulation needs to study will to connect these spaces on o this sloping ground.

During the first design stage, what design processes do you use when designing a building on the ground?

- Firstly, analyse the site by doing different studies, such as topographical, hydrological and soil analysis, and if the project is at an urban scale, we need to study the pedestrian circulation roots.
- Secondly, understanding the surrounding contexts' infrastructure and the land dimension then specify the construction's starting and endpoint.

Phase(2)Historical development:

Do you think this timeline accurately represents the development of physical building and ground designs? Or do you want to change anything?

- I think the timeline is studied very well, and it shows a significant changing of understanding the relationship with the ground.
- The timeline covers the significant movement, which is essential to start understanding.

Phase(3)Resources:

4. Which of the following do you consider useful resources that help illustrate the building and ground relationship?

- Written academic papers and articles (academic literature)**
 - Case studies (photographs) of projects/architectural precedents**
 - Others (please specify)**
- Mostly images of case studies and new project.

5. Are you aware of any analytical or generative design tools which can help you design a building in relation to the ground? If yes, can you please specify?

- As far as I know there is no tools can help me to design or analysis a building in relation to the ground.

Section (Three)Building and ground relationship taxonomy (approximately 20 minutes):

Phase(1)Taxonomy validation

Is this taxonomy information useful for architects during the early design stage? Do you want to add or delete? (Feel free to describe by drawing the relationship that requires improvement)

Appendix

- Yes, this taxonomy will be helpful to be used in the early design stage.
- It will allow defining the designer path or why to tackle the ground.
- Also, it gives the designer more option to choose from.
- For example, if the designer used the interlocking approach, he would have different interlock approaches, making it easier to define an approach suitable for the project.

How can the previous diagram be improved?

a. How can the title and labelling be improved?

- The title makes sense, however, need a definition for all of taxonomy.

b. How can the visual diagram be improved? (Feel free to describe by drawing the relationship that requires improvement)

- The diagram of landing and grounding and the rooting look similar, so need to define the difference between the two.
- It can be the rooting not vertical, and the landing and grounding are vertical.
- The diagram can also be expanded to tackle different aspects of the relation, such as environmental, structure, and programming.
- Also, it needs a legend will help to understand the diagram colour better.

Phase(2)Importance of taxonomy

In your opinion, how important is it to have a specific building and ground relationship taxonomy in the early design stage? Why?

- Yes, it is essential.
- You want to make sure that the design is harmonies with the surrounding urban, and one of the crucial factors of the urban fabric is the level “the ground level”.
- If you want to make the design special, we must tackle the architectural facade or the ground? and I think the ground will be more vital because it affects the human more.
- Moreover, it is essential from the early design stage to choose the right relationship and show a wide range of possible solution according to the building relation with the ground.

Section (Four)A computational design tool to cluster and classify building and ground relationships (approximately 10 minutes):

Phase(1)Importance of the computational design tool

Do you, as an architect/ academic, think it is important during the early design stage to have a computational tool that can classify and cluster the building and ground precedents into different groups?

- Yes

Appendix

Why do you think this computational tool is important/not important?

- Besides, it gives a wide range of possible solution according to the building relation with the ground, it gives an idea of the building and ground relationship and let you focuses more on this problem first not on the interior design “a horizontal plan”.

Phase(2)The computational design tool benefit

How do you think this building and ground relationship taxonomy will benefit architects and the architectural discipline during the early design stage?

- I designed the project from inside to outside; however, after seeing this interview, I will now think more about designing the building from outside to inside and not only considering the environmental aspect but also how the building meets the ground.

Are you happy to see the result of the tool?

- **Yes, I would like to see the result.**
- Finally, I would like to thank you to show me a massing part of our design process which is the "ground". I'm working now for more than 10 years and never think about the ground relationship. so, thank you.

End the interview

Appendix

Interview # 2 - Architect

Date of Interview: 27/01/2021 (18:00 pm – 19:03 pm)

Section (One) General information (approximately five minutes):

1. What is your profession?
 - Academic staff
2. How long have you been working in your role?
 - 10– 14 years
3. Please provide two or three examples of building and ground relationship projects or research in which you have participated?

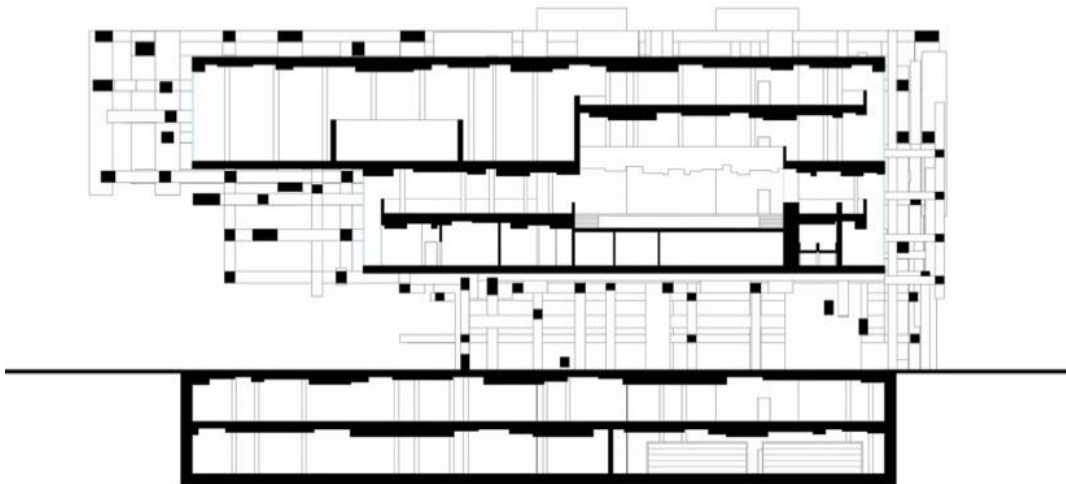
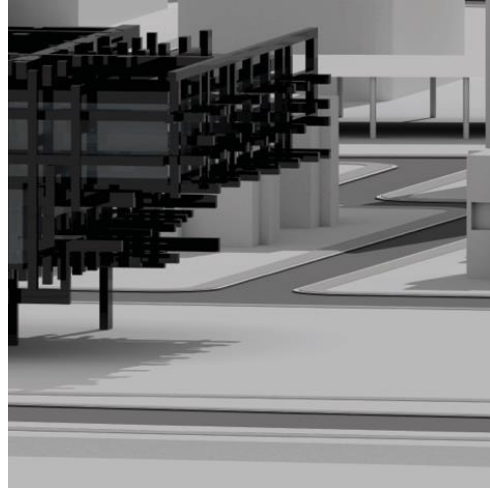

SECTION C-C

SECTION
1/16"
0 1 2 3 4

Section (Two) Architectural designs for the building and ground relationship

(approximately 15 minutes):

Phase(1) Issues and challenges:

- 4. What types of ground form part of your designs?**
 - flat ground.
- 5. What types of ground do you prefer to use in your designs?**
 - I prefer to work with both a flat ground, and topography ground.
- 6. What issues or challenges require consideration during the first stage of building design on flat or sloped ground?**
 - On the sloping ground, you need to study the slope and link your design to this sloping ground.
 - On the flat ground, there is no challenge because interaction with the flat ground will be mostly flat. Also, the interaction with the flat ground is boring.
- 1.1. You mention that the interaction with the flat ground is boring!! Do you know that you have a diversity of option such as the Pilotis to use the ground for more interactive activity on flat ground?**
 - Yes, you right. I mean in the flat ground you make the opportunity, but, in the sloping ground, the ground makes the opportunity, so that what I meant by “boring”.
- 2. During the first design stage, what design processes do you use when designing a building on the ground?**
 - Firstly, determine the kind of the ground if its flat or have different level.
 - Secondly, understanding the ground or soil specification if the designer can cut or fill on to the ground.
- 2.1. What about the analysis of the surrounding context?**
 - Yes, that important to analysis all the surrounding contexts.

Phase(2) Historical development:

- 3. Do you think this timeline accurately represents the development of physical building and ground designs? Or do you want to change anything?**
 - I think the timeline has represented the development of the relationship between the building and ground during this period.
 - I can observe here on the contemporary period have a more sophisticated approach to the ground because of the CAD and Parametricism revolution.
 - Also, I think after the 1960, the architect starts to “shape the ground” and give it more effect to the building.

Phase(4) Resources:

Appendix

4. Which of the following do you consider useful resources that help illustrate the building and ground relationship?

- a. Written academic papers and articles (academic literature)
- b. Case studies (photographs) of projects/architectural precedents
- c. Others (please specify)

- I will go to (a) and (b), I will start with an academic article to read how the building meets the ground and then go to case studies to imagine this relationship.
- The papers will also give me the limitation and the benefit of this relationship.

5. Are you aware of any analytical or generative design tools which can help you design a building in relation to the ground? If yes, can you please specify?

- I am not sure. Nevertheless, no tool looks to the building and ground problem to classify or cluster or even generate an alternative to how the building can meet the ground.

Section (Three) Building and ground relationship taxonomy (approximately 20 minutes):

Phase(3) Taxonomy validation

6. Is this taxonomy information useful for architects during the early design stage? Do you want to add or delete? (Feel free to describe by drawing the relationship that requires improvement)

- Yes, this is important and useful, also do you think about the integration between two categories such as interlock and separation at the same time? For example, the design that I give you on to the 3rd question has two way of meeting the ground adherence and at the same time separation on columns.
- Researcher, Yes, right some examples have two relationships, but you will be classified into a more dominant relationship. What is interesting is that you start to think about this taxonomy and try to classify your project to this provided taxonomy.
- Yes, we can combine this relationship and come up with a new way.



7. How can the previous diagram be improved?

d. How can the title and labelling be improved?

Appendix

- I think it fine, but you have 3 Topography I think you need to specify every one such as interlock topography or separation topography.

e. How can the visual diagram be improved? (Feel free to describe by drawing the relationship that requires improvement)

Phase(4)Importance of taxonomy

8. In your opinion, how important is it to have a specific building and ground relationship taxonomy in the early design stage? Why?

- The building and ground are part of architecture design and is also part of the architectural solution before you design you have to think about the ground and the relationship with the ground.
- The taxonomy is essential because in the first stage of design, you have to imagine all kinds of relationships, so you don't need to focus only on one class such as separation and neglecting others.

Section (Four)A computational design tool to cluster and classify building and ground relationships (approximately 10 minutes):

Phase(3)Importance of the computational design tool

9. Do you, as an architect/ academic, think it is important during the early design stage to have a computational tool that can classify and cluster the building and ground precedents into different groups?

- Yes and NO. If this tool gives to students, it will not be essential and not useful to them, because you need to give them a chance to discover all relationship by studying and learning, not by giving them a tool.
- However, if this tool will give to the architectural practice, this will help save a time and give them a larger picture to all relationship with the ground.

10. Why do you think this computational tool is important/not important?

- Yes, for the previous reason that I discuss

Phase(4)The computational design tool benefit

11. How do you think this building and ground relationship taxonomy will benefit architects and the architectural discipline during the early design stage?

- will help save a time and give them a larger picture to all relationship with the ground.

12. Are you happy to see the result of the tool?

- yes, that will be great.

End the interview

Appendix

Interview # 3

Date of Interview: 03/02/2021 (20:00 pm – 21:10 pm)

Section (One)General information (approximately five minutes):

1. What is your profession?

- Both, Academic staff and Architectural professional.

2. How long have you been working in your role?

- More than 30 years as Academic staff.
- More than 52 years as Architectural professional.

3. Please provide two or three examples of building and ground relationship projects or research in which you have participated?

- In the research: Crystallizing the relationship between architecture and landscape architecture.
- In the practice: Jabal Omar project in Makka, Bohierat city and Ekram village at Al Baha in Saudi Ariba.

Section (Two)Architectural designs for the building and ground relationship (approximately 15 minutes):

Phase(1)Issues and challenges:

4. What types of ground form part of your designs?

- Most of the work was urban projects, which means the ground is flat, but there are important exceptions, such as “Jabal Omar project” in Makkah, which has various and robust typography. In this project, we study the slop and categorise it into different conditions to deal with all this condition with the right treatment, so we deal with these different situations using basic landscape unite.
- Also, in “Jabal Omar project” we tried to mimic the mountain topography without digging or cutting in the mountain by putting the building on to terraces, to maximises the view, helping the ventilation of drafting air and minimise the cutting on to the mountain. All idea was based on understanding the ground and the relationship between the building and the ground.
- There is another project “Bohierat city”. The design was U-shape was designed to open the view and respect the other private.
- Another project is Ekram village at Al Baha in Saudi Ariba, housing for ageing people. This project has a strong topography, so the slope was designed as an architecture terraces, to mimic the existing cultural landscape. Also, we designed bridge to connect

Appendix

the houses with the services so the movement will be more comfortable for the ageing people.

5. What types of ground do you prefer to use in your designs?

- I prefer the topography site because the topography gives characteristic to the site. Moreover, prefer the slope that faces the prevailing wind or the views, to give more three-dimension diversity and variety in the responses.

6. What issues or challenges require consideration during the first stage of building design on flat or sloped ground?

- We deal with two main deliverables, the ground "site" and the architectural program "function program" on any design. The challenge is to analyse the site and determine the basic landscape unit and come up with the advantage and disadvantage. The second challenge is how to match the function program with the existing ground. So, what I suggest is to start to the ground and respond to the architectural solution to the ground that will be nicer than the conventional solution that builds the road and the building and leaves the rest for the landscape opening.

7. During the first design stage, what design processes do you use when designing a building on the ground?

- I think I answered this question "on question 6".

Phase(2)Historical development:

8. Do you think this timeline accurately represents the development of physical building and ground designs? Or do you want to change anything?

I think your right the most of le Corbusier work is lifting from the ground, but I think you need to add the next le Corbusier revolution after his travelling to Greek and north Africa. Le Corbusier changes his approach from the "machine house" to "play of masses brought together in light". So, I think it essential to the Ronchamp chapel. If you are generalising the diagrams is look right and good. Frank Lloyd wright his work is extruded from the natural, such as the Falling water you can fell the Waterfall is extruded from the building and can read the Falling water in two related to the ground the interlock and separation or flaying from the mountain. However, Mies van der rohe has a different attitude to the ground: the building is deblending from the neutral, opposite way from Frank Lloyd wright. Also, to give Mies van der rohe credit, the huge stairs that he mead in the Crown Hall become a social space. Cristofer alexander when he mentions that the stars can become a social space spatially in the university. This is a comment that I think it can give the timeline more retches.

Appendix

Phase(3)Resources:

9. Which of the following do you consider useful resources that help illustrate the building and ground relationship?
- Written academic papers and articles (academic literature)
 - Case studies (photographs) of projects/architectural precedents
 - Others (please specify)
- I think the Cases studies is the strongest one, which can stay in the architect mined for a long time. However, written academic paper and book it's important too. So, both will give the architect a strong understanding of the issue.
10. Are you aware of any analytical or generative design tools which can help you design a building in relation to the ground? If yes, can you please specify?
- no, manually

Section (Three)Building and ground relationship taxonomy (approximately 20 minutes):

Phase(1)Taxonomy validation

11. Is this taxonomy information useful for architects during the early design stage? Do you want to add or delete? (Feel free to describe by drawing the relationship that requires improvement)
- Sure, it's important. There is no hesitation.
12. How can the previous diagram be improved?
- How can the title and labelling be improved?
- Metaphor's word is it hard to understand
- How can the visual diagram be improved? (Feel free to describe by drawing the relationship that requires improvement)
- The horizontal rows were clear however the vertical rows not. I think need to add the key legend next to the diagrams.

Phase(2)Importance of taxonomy

13. In your opinion, how important is it to have a specific building and ground relationship taxonomy in the early design stage? Why?
- Any knowledge is important. The architects who know two relationships are not better than the architects who know ten relationships. Knowing more forms of relationship will help the architects solve the problem better functionally and formally.

Section (Four)A computational design tool to cluster and classify building and ground relationships (approximately 10 minutes):

Appendix

Phase(1)Importance of the computational design tool

14. Do you, as an architect/ academic, think it is important during the early design stage to have a computational tool that can classify and cluster the building and ground precedents into different groups?

- Yes, it useful as education information to extend the architect knowledge. if it necessary for every project I think it depend on the project.

15. Why do you think this computational tool is important/not important?

- As I mentioned it important for the architect as education information in all stages not only first stage design.

Phase(2)The computational design tool benefit

16. How do you think this building and ground relationship taxonomy will benefit architects and the architectural discipline during the early design stage?

- Already answer.

17. Are you happy to see the result of the tool?

- Sure, I will be happy.

End the interview

Appendix

Interview # 4

Date of Interview: 15/02/2021 (16:00 pm – 16:55 pm)

Section (One) General information (approximately five minutes):

1. What is your profession?

- Both, now I'm Academic staff and before, I was Architectural practice.

2. How long have you been working in your role?

- Total is 22 years.
- 10 years as architectural practice and 10 years as Academic staff.

3. Please provide two or three examples of building and ground relationship projects or research in which you have participated?

- 12 dwellings in Jaen -bRijUNi architects, this projects that I worked on I think has strong relation to the ground because it embedded in the ground.



Section (Two) Architectural designs for the building and ground relationship

(approximately 15 minutes):

Phase(1) Issues and challenges:

4. What types of ground form part of your designs?

- Most likely the slope ground. for examples the “12 dwellings in Jaen” is built in sloped ground so it become project status of landscape or nature.

5. What types of ground do you prefer to use in your designs?

- I prefer a flat ground, which is an abstract context.

5.5. Why you choose flat?

- I choose flat because it gives freedom when you design and it easier to tackle. I want a blank page to start with. I do not want the topography limitation.

6. What issues or challenges require consideration during the first stage of building design on flat or sloped ground?

Appendix

- The first challenge is structural challenging how to ground the building in the sloping ground, and from the conceptual and programmatic point of view on how to take advantage of the ground to enhance the design.

7. During the first design stage, what design processes do you use when designing a building on the ground?

- It starts with analysing the context and the ground, then how this concept will set in the ground and how tectonic the building is.

Phase(2)Historical development:

8. Do you think this timeline accurately represents the development of physical building and ground designs? Or do you want to change anything?

- Yes, it is well studied, and it is nice to see the War I and War II in the timeline, because as Anthony Vidler says, "the wars are the ones shaping the different periods in the history of architecture". It will also be helpful to cluster the similar architect approach like Le Corbusier and Renzo bino, so we can know how this timeline linked together.

Phase(3)Resources:

9. Which of the following do you consider useful resources that help illustrate the building and ground relationship?

- Written academic papers and articles (academic literature)**
- Case studies (photographs) of projects/architectural precedents**
- Others (please specify)**

- The case studies are the most important because you can see the relationship clearly on images, and academic paper also as academic if you want to read more about the building. I can add one more thing, which is the 3d model.

10. Are you aware of any analytical or generative design tools which can help you design a building in relation to the ground? If yes, can you please specify?

- I think no, there is no tool can help in this issue which is building and ground.

Section (Three)Building and ground relationship taxonomy (approximately 20 minutes):

Phase(1)Taxonomy validation

11. Is this taxonomy information useful for architects during the early design stage? Do you want to add or delete? (Feel free to describe by drawing the relationship that requires improvement)

- This taxonomy is useful to understand all kind of building and ground relationship and I think its Inclusive.

12. How can the previous diagram be improved?

Appendix

a. How can the title and labelling be improved?

- That clear to me and I can understand you mean.

b. How can the visual diagram be improved? (Feel free to describe by drawing the relationship that requires improvement)

- I think it clear but need a key for the whole diagram.

Phase(2)Importance of taxonomy

13. In your opinion, how important is it to have a specific building and ground relationship taxonomy in the early design stage? Why?

- It is vital to have a similar taxonomy to have a larger view of all the taxonomy and compare them. For example, the topography approach has three forms into different class interlock and separation and adherence, so the designer can think if he wants a large building interlock with the ground or a smaller discrete building raised on a column.

Section (Four)A computational design tool to cluster and classify building and ground relationships (approximately 10 minutes):

Phase(1)Importance of the computational design tool

14. Do you, as an architect/ academic, think it is important during the early design stage to have a computational tool that can classify and cluster the building and ground precedents into different groups?

- Yes, I think it's important, as I suggested to see it in the timeline.

15. Why do you think this computational tool is important/not important?

- This tool is important to give you wide range of approaches to the ground whether similar or different which will help at the early design to see how your approach is cluster within the architectural history or timeline you provided early.

Phase(2)The computational design tool benefit

16. How do you think this building and ground relationship taxonomy will benefit architects and the architectural discipline during the early design stage?

- As I said early, I think it will benefit the architect to give them a wide range of approaches to the ground.

17. Are you happy to see the result of the tool?

- Yes, I am happy to see that, and I will read the paper you published regarding this critical topic.

End the interview

Interview # 5

Date of Interview: 25/02/2021 (1:00 pm – 1:56 pm)

Section (One) General information (approximately five minutes):

1. What is your profession?

- I was Architectural practice working as architect and urban designer.

2. How long have you been working in your role?

- Total experience more than 10 years.

3. Please provide two or three examples of building and ground relationship projects or research in which you have participated?

Section (Two) Architectural designs for the building and ground relationship (approximately 15 minutes):

Phase(1) Issues and challenges:

4. What types of ground form part of your designs?

- Flat ground is the most.

5. What types of ground do you prefer to use in your designs?

- I prefer a terraces ground or stairs ground not flat not slope.

1.1. Why you choose terraces ground?

- I choose terraces ground because the opportunity that this kind of ground gives me and dealing with terraces ground is not challenging like the slope ground because the terraces ground is a repetitive flat ground with different level.

6. What issues or challenges require consideration during the first stage of building design on flat or sloped ground?

- The slope elevation spot is not equal, and may the design have a weird edge meeting the ground. Normally, when I faced any sloping ground first, I tried to transform this slope to terraces ground to work with quickly.
- There are not any Features in the flat ground that I can use to develop the design. Also, the flat land has no identity or characteristic that can benefit the building mass.

7. During the first design stage, what design processes do you use when designing a building on the ground?

- Study topography if the topography has a small changing in the contour level, so I will consider it as flat ground. However, if this topography has a significant level change, I will consider it organic ground requiring special treatment. Also, the surrounding context needs to be studied and water analysis and environmental analyses as well.

Appendix

Phase(2)Historical development:

8. Do you think this timeline accurately represents the development of physical building and ground designs? Or do you want to change anything?

- It looks that the modern architect was deal with the ground as a receiver; however, after 1950, they work with two things (Building as one and the ground as other) to find a relation between them.
- This timeline represents the development in an excellent exact way.

Phase(3)Resources:

9. Which of the following do you consider useful resources that help illustrate the building and ground relationship?

- a. **Written academic papers and articles (academic literature)**
- d. **Case studies (photographs) of projects/architectural precedents**
- e. **Others (please specify)**
- The case studies are the most important, so I can analyse them using my knowledge and academic paper to read more about the building and justifying the purpose of the relationship.

10. Are you aware of any analytical or generative design tools which can help you design a building in relation to the ground? If yes, can you please specify?

- I think the GIS it can help in this. however, there is no tools specifically help to design the building in the ground. normally I model the relationship to the ground manually.

Section (Three)Building and ground relationship taxonomy (approximately 20 minutes):

Phase(1)Taxonomy validation

11. Is this taxonomy information useful for architects during the early design stage? Do you want to add or delete? (Feel free to describe by drawing the relationship that requires improvement)

- It is useful because it gives multiple solutions for the same ground. Sometimes the architect ignores some interesting features in the ground because he does not have a full understanding of all this relationship. For examples, the topography has three different solutions. An architect goes typically to the interlock ones and ignores the other here; you give us all the relationship, which is helpful.

12. How can the previous diagram be improved?

- a. **How can the title and labelling be improved?**

Appendix

- The labelling is working well with the diagram.

b. How can the visual diagram be improved? (Feel free to describe by drawing the relationship that requires improvement)

- key need to be added to the diagram.
- The colour of the diagram can be removed.

Phase(2)Importance of taxonomy

13. In your opinion, how important is it to have a specific building and ground relationship taxonomy in the early design stage? Why?

- This information of the taxonomy is an excellent reference to any architectural work in the field of research or practices. While you are designing a building, it is hard to know or remember all the relationships, so you need this taxonomy to be available at the early design stage.
- The starting point for any project is the ground. The ground issue starts from the early-stage design, so in this phase, you should have this relationship diversity to benefit from this taxonomy.
- Moreover, I can use this taxonomy to help me searching on the internet to look for an architectural precedent as case studies to find similar cases I can learn from it.

Section (Four)A computational design tool to cluster and classify building and ground relationships (approximately 10 minutes):

Phase(1)Importance of the computational design tool

14. Do you, as an architect/ academic, think it is important during the early design stage to have a computational tool that can classify and cluster the building and ground precedents into different groups?

- Yes, I think it is useful.

15. Why do you think this computational tool is important/not important?

- Primary, save your time and effort looking for similar architectural precedents. Educate me more about the different concepts of reaching the ground.

Phase(2)The computational design tool benefit

16. How do you think this building and ground relationship taxonomy will benefit architects and the architectural discipline during the early design stage?

- Answered previously

17. Are you happy to see the result of the tool?

- Yes sure. I would be happy.



















End the interview

Appendix: IV
Architectural Precedents Dataset

Appendix

ground1		Friday, July 1, 2022 10:51:28 PM					
ID	Architect Name	Building Name	Status	Type	Building Type	Year	Continent
1	Ludwing Mies Van der Rohe	Seagram Building	Built	Building	Public	1958	North America
2	Ludwing Mies Van der Rohe	Barcelona Pavilion	Built	Building	Public	1929	Europe
3	Ludwing Mies Van der Rohe	Farnsworth House	Built	Building	Residential	1951	North America
4	Ludwing Mies Van der Rohe	Villa Tugendhat	Built	Building	Residential	1930	Europe
5	Ludwing Mies Van der Rohe	Crown Hall	Built	Building	Public	1956	North America
6	Ludwing Mies Van der Rohe	Lemke House	Built	Building	Residential	1933	Europe
7	Ludwing Mies Van der Rohe	Highfield House Condominium	Built	Building	Residential	1964	North America
8	Le Corbusier	Villa Savoye	Built	Building	Residential	1931	Europe
9	Le Corbusier	Unité d'habitation	Built	Building	Residential	1952	Europe
10	Le Corbusier	Notre Dame du Haut	Built	Building	Public	1955	Europe





















Appendix

Country	City	Period of history	image	Diagram	Main Relationship	Touches Ground
United States of America	New York	Postmodernism			Separation	Column on Plinth
Spain	Barcelona	Modernism			Adherence	Plinth
United States of America	Plano	Postmodernism			Separation	Artificial Ground
Czech Republic	Brno	Modernism			Interlock	Foundation
United States of America	Chicago	Postmodernism			Adherence	Plinth
Germany	Berlin	Modernism			Adherence	Absence of level
United States of America	Baltimore	Postmodernism			Separation	Column on Plinth
France	Poissy	Modernism			Separation	Ungrounded
France	Marseille	Postmodernism			Separation	Ungrounded
France	Ronchamp	Postmodernism			Adherence	Absence of level

Appendix

ID	Architect Name	Building Name	Status	Type	Building Type	Year	Continent
11	Le Corbusier	Sainte Marie de La Tourette	Built	Building	Public	1957	Europe
12	Le Corbusier	Villa Stein or Villa de Monzie	Built	Building	Residential	1927	Europe
13	Le Corbusier	Villa Shodhan	Built	Building	Residential	1956	Asia
14	Le Corbusier	Philips Pavilion,World's Fair pavilion	Built	Building	Public	1958	Europe
15	Le Corbusier	Pavillon Suisse	Built	Building	Public	1930	Europe
16	Le Corbusier	Mill Owners' Association Building	Built	Building	Public	1954	Asia
17	Le Corbusier	Carpenter Center,Harvard University	Built	Building	Public	1962	North America
18	Charilaos Kythreotis	Pavilion at Architect's Residence	Built	Building	Public	2013	Europe
19	Aidan Doyle and Sarah Wan	Philip Johnson's New York World Fair pavilion	Unbuilt	Building	Public	2016	Unlocated
20	Le Corbusier	Government Museum and Art Gallery	Built	Building	Public	1968	Asia
21	Le Corbusier	Sanskar Kendra	Built	Building	Public	1956	Asia

















Appendix

Country	City	Period of history	image	Diagram	Main Relationship	Touches Ground
France	Éveux	Postmodernism			Separation	Ungrounded
France	Garches	Modernism			Adherence	Absence of level
India	Ahmedabad	Postmodernism			Adherence	Absence of level
Belgium	Brussels	Postmodernism			Adherence	Plinth
France	Paris	Modernism			Separation	Ungrounded
India	Ahmedabad	Postmodernism			Separation	Ungrounded
United States of America	Massachusetts	Postmodernism			Separation	Ungrounded
Cyprus	Nicosia	Contemporary			Separation	Artificial Ground
Unlocated	Unlocated	Contemporary			Separation	Ungrounded
India	Chandigarh	Contemporary			Separation	Ungrounded
India	Ahmedabad	Contemporary			Separation	Ungrounded

Appendix

ID	Architect Name	Building Name	Status	Type	Building Type	Year	Continent
22	Frank Lloyd Wright	Fallingwater	Built	Building	Residential	1935	North America
23	Frank Lloyd Wright	Frank Lloyd Wright Home and Studio	Built	Building	Residential	1909	North America
24	Frank Lloyd Wright	Taliesin West	Built	Building	Residential	1937	North America
25	Frank Lloyd Wright	Robie House	Built	Building	Residential	1909	North America
26	Frank Lloyd Wright	Martin House Complex	Built	Building	Residential	1905	North America
27	Frank Lloyd Wright	Ennis House	Built	Building	Residential	1924	North America
28	Frank Lloyd Wright	Hollyhock House	Built	Building	Residential	1921	North America
29	Frank Lloyd Wright	Unity Temple	Built	Building	Public	1908	North America
30	Frank Lloyd Wright	Kentuck Knob	Built	Building	Residential	1956	North America
31	Frank Lloyd Wright	Johnson House,Wingspread	Built	Building	Residential	1939	North America
32	Frank Lloyd Wright	Millard House	Built	Building	Residential	1923	North America















Appendix

Country	City	Period of history	image	Diagram	Main Relationship	Touches Ground
United States of America	Pennsylvania	Modernism			Interlock	Foundation
United States of America	Oak Park	Modernism			Adherence	Plinth
United States of America	Scottsdale	Modernism			Interlock	Foundation
United States of America	Chicago	Modernism			Adherence	Plinth
United States of America	Buffalo	Modernism			Adherence	Plinth
United States of America	Los Angeles	Modernism			Interlock	Foundation
United States of America	Los Angeles	Modernism			Adherence	Plinth
United States of America	Oak Park	Modernism			Adherence	Absence of level
United States of America	Dunbar	Postmodernism			Interlock	Foundation
United States of America	Wind Point	Modernism			Adherence	Absence of level
United States of America	Pasadena	Modernism			Interlock	Foundation

Appendix

ID	Architect Name	Building Name	Status	Type	Building Type	Year	Continent
33	Frank Lloyd Wright	Dana Thomas House	Built	Building	Residential	1904	North America
34	Frank Lloyd Wright	David and Gladys Wright House	Built	Building	Residential	1952	North America
35	Frank Lloyd Wright	ASU Gammage	Built	Building	Public	1964	North America
36	Frank Lloyd Wright	Meyer May House	Built	Building	Residential	1909	North America
37	Frank Lloyd Wright	George Sturges House	Built	Building	Residential	1939	North America
38	Frank Lloyd Wright	Pope-Leighey House	Built	Building	Residential	1940	North America
39	Frank Lloyd Wright	Larkin Administration Building	Built	Building	Public	1904	North America
40	Frank Lloyd Wright	Rose Pauson House	Built	Building	Residential	1942	North America
41	Frank Lloyd Wright	Massaro House	Built	Building	Residential	1949	North America
42	Frank Lloyd Wright	Sol Friedman House	Built	Building	Residential	1948	North America
43	Frank Lloyd Wright	Solomon R. Guggenheim Museum	Built	Building	Public	1959	North America













Appendix

Country	City	Period of history	image	Diagram	Main Relationship	Touches Ground
United States of America	Springfield	Modernism			Adherence	Plinth
United States of America	Phoenix	Postmodernism			Separation	Ungrounded
United States of America	Tempe	Postmodernism			Adherence	Plinth
United States of America	Grand Rapids	Modernism			Adherence	Plinth
United States of America	Los Angeles	Modernism			Interlock	Grounded
United States of America	Alexandria	Modernism			Adherence	Absence of level
United States of America	Buffalo	Modernism			Adherence	Plinth
United States of America	Phoenix	Modernism			Interlock	Foundation
United States of America	Lake Mahopac	Postmodernism			Interlock	Foundation
United States of America	Pleasantville	Modernism			Interlock	Foundation
United States of America	Manhattan	Postmodernism			Interlock	Foundation

Appendix

ID	Architect Name	Building Name	Status	Type	Building Type	Year	Continent
44	Frank Lloyd Wright	First Unitarian Society of Madison	Built	Building	Public	1951	North America
45	Richard Neutra	Kaufmann Desert House	Built	Building	Residential	1946	North America
46	Richard Neutra	Lovell House	Built	Building	Residential	1929	North America
47	Richard Neutra	Singleton House	Built	Building	Residential	1959	North America
48	Richard Neutra	Kronish House	Built	Building	Residential	1955	North America
49	Richard Neutra	Chuey House	Built	Building	Residential	1956	North America
50	Richard Neutra	Constance Perkins House	Built	Building	Residential	1955	North America
51	Richard Neutra	Casa Bucerius House	Built	Building	Residential	1966	Europe
52	Richard Neutra	Rang house	Built	Building	Residential	1961	Europe
53	Adolf Loos	Villa Müller	Built	Building	Residential	1930	Europe
54	John Hejduk	Wall house II	Built	Building	Residential	1973	Europe

















Appendix

Country	City	Period of history	image	Diagram	Main Relationship	Touches Ground
United States of America	Shorewood Hills	Postmodernism			Interlock	Foundation
United States of America	Palm Springs	Modernism			Adherence	Plinth
United States of America	Los Angeles	Modernism			Interlock	Foundation
United States of America	Los Angeles	Postmodernism			Adherence	Plinth
United States of America	Beverly Hills	Postmodernism			Adherence	Plinth
United States of America	Hollywood Hills	Postmodernism			Interlock	Foundation
United States of America	Pasadena	Postmodernism			Interlock	Foundation
Switzerland	Ticino	Postmodernism			Adherence	Absence of level
Germany	Tanus	Postmodernism			Interlock	Foundation
Czech Republic	Prague	Modernism			Interlock	Foundation
Netherlands	Groningen	Postmodernism			Separation	Ungrounded

Appendix

ID	Architect Name	Building Name	Status	Type	Building Type	Year	Continent
55	John Hejduk	Security	Built	Structure	Public	1989	Europe
56	John Hejduk	Lancaster/Hanover Masque Project	Unbuilt	Structure	Public	1983	Unlocated
57	Ron Herron	Archigram Walking City	Unbuilt	Urban	Public	1966	North America
169	Kengo Kuma	Kirosan Observatory	Built	Building	Public	1991	Asia
170	Kengo Kuma	Forest/Floor	Built	Building	Residential	2001	Asia
171	Glenn Murcutts	Ockens House	Built	Building	Residential	1977	Oceania
172	Peter Zumthor	Thermal baths in vals	Built	Building	Public	1996	Europe
173	Peter Zumthor	Topography of Terror	Built	Building	Public	2007	Europe
174	Cesar Pelli's	Urban Nucleus	Built	Urban	Residential	1966	North America
175	Norman Foster	Zayed National Museum	Unbuilt	Building	Public	2019	Asia
176	Norman Foster	The Sage Music Center	Built	Building	Public	2004	Europe

















Appendix

Country	City	Period of history	image	Diagram	Main Relationship	Touches Ground
Norway	Oslo	Postmodernism			Separation	Ungrounded
Unlocated	Unlocated	Postmodernism			Separation	Ungrounded
United States of America	New York	Postmodernism			Separation	Ungrounded
Japan	Oshima	Postmodernism			Interlock	Grounded
Japan	Karuizawa	Contemporary			Separation	Ungrounded
Australia	Oceania	Postmodernism			Interlock	Foundation
Switzerland	Graubunden	Postmodernism			Interlock	Grounded
Germany	Berlin	Contemporary			Interlock	Foundation
United States of America	Los Angeles	Postmodernism			Interlock	Foundation
United Arab Emirates	Abu Dhabi	Contemporary			Interlock	Grounded
United Kingdom	Gateshead	Contemporary			Adherence	Plinth

Appendix

ID	Architect Name	Building Name	Status	Type	Building Type	Year	Continent
177	Norman Foster	Bund Finance Centre	Built	Building	Public	2017	Asia
178	Bjarke Ingels Group	SØF Maritime Museum	Built	Building	Public	2014	Europe
179	David Chipperfield Architects	Colección Jumex	Built	Building	Public	2013	North America
180	LDA.iMda	House in the Orchard	Built	Building	Residential	2019	Europe
181	Weiss/Manfredi	Olympic Sculpture Park	Built	Landscape	Public	2007	North America
182	Foreign Office Architect	Meydan - Umraniye	Built	Building	Public	2007	Europe
183	Eduardo Souto de Moura	Municipal Stadium of Braga	Built	Building	Public	2003	Europe
184	Alvaro Siza	Leca Swimming Pool	Built	Structure	Public	1966	Europe
185	R & Sie Architecture	Asphalt Sopt	Built	Structure	Public	2003	Asia
186	MVRDV	Villa Vpro	Built	Building	Residential	1997	Europe
187	Joakim Hoen	Summer Seaside House	Unbuilt	Building	Residential	2012	Europe













Appendix

Country	City	Period of history	image	Diagram	Main Relationship	Touches Ground
China	Shanghai	Contemporary			Separation	Ungrounded
Denmark	Maritime	Contemporary			Interlock	Grounded
Mexico	Mexico City	Contemporary			Separation	Column on Plinth
Italy	San Miniato	Contemporary			Separation	Ungrounded
United States of America	Chicago	Contemporary			Interlock	Grounded
Turkey	Istanbul	Contemporary			Interlock	Grounded
Portugal	Braga	Contemporary			Interlock	Grounded
Portugal	Porto	Postmodernism			Interlock	Grounded
Japan	Tokamashi	Contemporary			Interlock	Grounded
Netherlands	Hilversum	Postmodernism			Separation	Ungrounded
Norway	Norway Seaside	Contemporary			Adherence	Absence of level

Appendix

ID	Architect Name	Building Name	Status	Type	Building Type	Year	Continent
188	Smiljan Radic	Serpentine Gallery Pavilion	Built	Building	Public	2014	Europe
189	Toyo Ito	Serpentine Gallery Pavilion	Built	Building	Public	2002	Europe
190	Enric Miralles & Carme Pinos	Olympic Archery Range	Built	Building	Public	1992	Europe
191	Institute for Advanced Architecture of Catalonia	Endesa Pavilion	Built	Building	Public	2011	Europe
192	Diller Scofidio and Renfro	Blur Building	Built	Building	Public	2002	Europe
193	Alvaro Siza	Casa Avelino Duarte	Built	Building	Residential	1985	Europe
194	Toyo Ito	National Taichung, Opera House	Built	Building	Public	2014	Asia
195	Toyo Ito	Tower of Winds	Built	Building	Public	1987	Asia
196	UNStudio	Three Museums One Square	Unbuilt	Urban	Public	2013	Asia
197	Thom Mayne	41 Cooper Square	Built	Building	Public	2009	North America
198	Thom Mayne	Centro Sports Center	Unbuilt	Building	Public	2004	North America











Appendix

Country	City	Period of history	image	Diagram	Main Relationship	Touches Ground
United Kingdom	London	Contemporary			Separation	Ungrounded
United Kingdom	London	Contemporary			Adherence	Absence of level
Spain	Barcelona	Postmodernism			Interlock	Grounded
Spain	Barcelona	Contemporary			Adherence	Absence of level
Switzerland	Neuchatel	Contemporary			Separation	Ungrounded
Portugal	Ovar	Postmodernism			Adherence	Absence of level
Taiwan	Taichung	Contemporary			Adherence	Absence of level
Japan	Yokohama	Postmodernism			Separation	Ungrounded
China	Guangzhou	Contemporary			Separation	Ungrounded
United States of America	New York	Contemporary			Separation	Ungrounded
Mexico	Guadalajara	Contemporary			Separation	Ungrounded

Appendix

ID	Architect Name	Building Name	Status	Type	Building Type	Year	Continent
199	Thom Mayne	Air Force Memorial Competition	Unbuilt	Building	Public	2002	North America
200	Thom Mayne	Was Residence	Unbuilt	Building	Residential	1988	North America
201	Open Platform for Architecture (OPA)	Casa Brutale	Built	Building	Residential	2020	Europe
202	GilBartolomé Architects	Casa del Ancantilado Casa del Ancantilado	Built	Building	Residential	2015	Europe
203	Modscape Concept	Cliff House	Unbuilt	Building	Residential	2014	Oceania
204	WMR Arquitectos	Till House	Built	Building	Residential	2014	South America
205	MacKay-Lyons Sweetapple Architects	Cliff House	Built	Building	Residential	2013	North America
206	MacKay-Lyons Sweetapple Architects	Mirror Point Cottage	Built	Building	Residential	2015	North America
207	MacKay-Lyons Sweetapple Architects	Two Hulls	Built	Building	Residential	2011	North America
208	MacKay-Lyons Sweetapple Architects	De Vries House	Built	Building	Residential	2016	North America

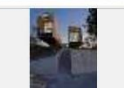
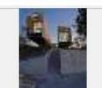









Appendix

Country	City	Period of history	image	Diagram	Main Relationship	Touches Ground
United States of America	Virginia	Contemporary			Interlock	Foundation
United States of America	Los Angeles	Contemporary			Interlock	Foundation
Italy	Naples	Contemporary			Interlock	Grounded
Spain	Salobreña	Contemporary			Interlock	Grounded
Australia	coastal	Contemporary			Interlock	Foundation
Chile	Los Arcos	Contemporary			Separation	Ungrounded
Canada	Nova Scotia	Contemporary			Separation	Ungrounded
Canada	Nova Scotia	Contemporary			Separation	Ungrounded
Canada	Nova Scotia	Contemporary			Interlock	Grounded
Canada	Nova Scotia	Contemporary			Adherence	Absence of level

Appendix

ID	Architect Name	Building Name	Status	Type	Building Type	Year	Continent
209	Borrmeister Architects	Scarborough Home	Built	Building	Residential	2017	Oceania
210	Matthias Arndt	Triangle Cliff House	Unbuilt	Building	Residential	2017	Unlocated
211	Design time	Container House	Unbuilt	Building	Residential	2019	Europe
212	Gonzalez Moix Architects	Temporary Housing	Unbuilt	Building	Residential	2014	South America
213	Gonzalez Moix Architects	Plaza Biblioteca Sur	Built	Building	Public	2017	South America
214	Fran Silvestre Architects	Casa del Acantilado	Built	Building	Residential	2012	Europe
215	Fran Silvestre Architects	House On The Rocks	Built	Building	Residential	2010	Europe
216	Gonzalez Moix Architects	Plaza Cultural Norte	Built	Building	Public	2016	South America
217	Vetsch Architects	Earth Homes	Built	Building	Residential	1979	Europe
218	Robert Oshatz	Chenequa Residence	Built	Building	Residential	2011	North America
219	Deca Architects	Aloni earth sheltered home	Built	Building	Residential	2008	Europe











Appendix

Country	City	Period of history	image	Diagram	Main Relationship	Touches Ground
New Zealand	Christchurch	Contemporary			Interlock	Foundation
Fictional	Fictional	Contemporary			Interlock	Foundation
Poland	Warsaw	Contemporary			Adherence	Absence of level
Peru	Pucusana	Contemporary			Interlock	Foundation
Peru	La Molina	Contemporary			Adherence	Absence of level
Spain	Calp	Contemporary			Interlock	Foundation
Spain	Valencia	Contemporary			Interlock	Foundation
Peru	La Molina	Contemporary			Interlock	Grounded
Switzerland	Dietikon	Postmodernism			Interlock	Grounded
United States of America	Milwaukee	Contemporary			Interlock	Foundation
Greece	Antiparos	Contemporary			Interlock	Grounded

Appendix

ID	Architect Name	Building Name	Status	Type	Building Type	Year	Continent
220	Bercy Chen Studio	Edgeland House	Built	Building	Residential	2012	North America
221	SeARCH, CMA	Villa Vals	Built	Building	Residential	2009	Europe
222	Longhi Architects	Pachacamac House	Built	Building	Residential	2008	South America
223	Nigel Kirkwood	Hobbit House	Built	Building	Residential	2016	Oceania
224	Zaha Hadid	The Opus	Built	Building	Public	2018	Asia
225	Walter Gropius	John F. Kennedy Federal Building	Built	Building	Public	1966	North America
226	Walter Gropius	Gropiushaus	Built	Building	Residential	1957	Europe
227	Walter Gropius	Bauhaus Dessau	Built	Building	Public	1927	Europe
228	I. M. Pei	Louvre Pyramid	Built	Building	Public	1984	Europe
229	I. M. Pei	Miho Museum	Built	Building	Public	1997	Asia
230	Oscar Niemeyer	Oscar Niemeyer Museum	Built	Building	Public	1978	South America









Appendix

Country	City	Period of history	image	Diagram	Main Relationship	Touches Ground
United States of America	Austin	Contemporary			Interlock	Grounded
Switzerland	Vals	Contemporary			Interlock	Grounded
Peru	Lima	Contemporary			Interlock	Grounded
Australia	Quindalup	Contemporary			Interlock	Grounded
United Arab Emirates	Dubai	Contemporary			Separation	Ungrounded
United States of America	Boston	Postmodernism			Separation	Ungrounded
Germany	Berlin	Postmodernism			Separation	Ungrounded
Germany	Dessau	Modernism			Adherence	Absence of level
France	Paris	Postmodernism			Interlock	Grounded
Japan	Kyoto	Postmodernism			Interlock	Foundation
Brazil	Curitiba	Postmodernism			Separation	Ungrounded

Appendix

ID	Architect Name	Building Name	Status	Type	Building Type	Year	Continent
231	Oscar Niemeyer	Niterói Contemporary Art Museum Source: https://www.yellowtrace.com.au/brazilian-architect-oscar-niemeyer	Built	Building	Public	1996	South America
232	Oscar Niemeyer	Attorney General building	Built	Building	Public	1995	South America
233	Robert Venturi	Venturi House	Built	Building	Residential	1964	North America
234	Minoru Yamasaki	Rainier Tower	Built	Building	Public	1971	North America
235	Lina Bo Bardi	The Dream House	Built	Building	Residential	1951	South America
236	Olson Kundig	Olson Cabin	Built	Building	Residential	2003	North America
237	John Wardle	The Shearers' Quarters	Built	Building	Residential	2011	Oceania
238	Marte Architects	Mountain Cabin	Built	Building	Residential	2010	Oceania
239	Robert Konieczny	Ark House	Built	Building	Residential	2011	Europe











Appendix

Country	City	Period of history	image	Diagram	Main Relationship	Touches Ground
Brazil	Rio de Janeiro Source: https://www.yellowtrace.com.au/brazilian-architect-oscar	Postmodernism			Separation	Ungrounded
Brazil	Brasilia	Postmodernism			Separation	Ungrounded
United States of America	Pennsylvania	Postmodernism			Adherence	Absence of level
United States of America	Seattle	Postmodernism			Separation	Ungrounded
Brazil	São Paulo	Postmodernism			Separation	Ungrounded
United States of America	Washington	Contemporary			Interlock	Foundation
Australia	Bruny Island	Contemporary			Adherence	Absence of level
Australia	Laterns	Contemporary			Adherence	Absence of level
Poland	Brenna	Contemporary			Adherence	Plinth

Appendix

ID	Architect Name	Building Name	Status	Type	Building Type	Year	Continent
240	Fritz + Fritz	M House	Built	Building	Residential	2011	South America
241	Edition Office	Fish Creek House	Built	Building	Residential	2016	Oceania
242	Vazio S/A	Cerrado House	Built	Building	Residential	2013	South America
243	Kraus Schönberg Architects	W House	Built	Building	Residential	2007	Europe
244	A for Architecture	Panorama House	Built	Building	Residential	2014	Asia
245	FORM/Kouichi Kimura Architects	Framing House	Built	Building	Residential	2015	Asia
246	Dekleva Gregorič Architects	Chimney House	Built	Building	Residential	2016	Europe
247	Spaceworkers	Casa Cabo de Vila	Built	Building	Residential	2015	Europe
248	Paul de Ruiter Architects	Villa Kogelhof	Built	Building	Residential	2006	Europe
249	Fernando Velasco + Paola Morales	Casa Alta	Built	Building	Residential	2010	South America
250	Andrade Morettin Arquitetos Associados	CJ House	Built	Building	Residential	2011	South America













Appendix

Country	City	Period of history	image	Diagram	Main Relationship	Touches Ground
Argentina	Lujan	Contemporary			Adherence	Absence of level
Australia	Victoria	Contemporary			Adherence	Absence of level
Brazil	Moeda	Contemporary			Adherence	Absence of level
Germany	Hamburg	Contemporary			Interlock	Grounded
India	Nashik	Contemporary			Separation	Ungrounded
Japan	Shiga	Contemporary			Adherence	Absence of level
Slovenia	Logatec	Contemporary			Adherence	Absence of level
Portugal	Paredes	Contemporary			Adherence	Plinth
Netherlands	Beveland	Contemporary			Separation	Ungrounded
Mexico	Huixquilucan	Contemporary			Interlock	Foundation
Brazil	São Paulo	Contemporary			Separation	Artificial Ground

Appendix

ID	Architect Name	Building Name	Status	Type	Building Type	Year	Continent
251	Petra Gipp Architektur	Forrester's House	Built	Building	Residential	2007	Europe
252	Open Y Office	House GePo	Built	Building	Residential	2012	Europe
253	Yuri Vital	Two Beams House	Built	Building	Residential	2016	South America
254	Carlos Torres Alcalde / Ruca Proyectos	La Quimera House	Built	Building	Residential	2015	South America
255	Titus Bernhard Architekten BDA	House 11 x 11	Built	Building	Residential	2011	Europe
256	Deegan Day Design LLC	C-Glass House	Built	Building	Residential	2014	North America
257	Jackson Clements Burrows Architects	Moonlight Cabin	Built	Building	Residential	2014	Oceania
258	Elding Oscarson	Mölle by the Sea	Built	Building	Residential	2013	Europe
259	Studio mk27	Redux House	Built	Building	Residential	2009	South America
260	Stpmj	Shear House	Built	Building	Residential	2016	Asia
261	Davide Macullo Architects	House in Lumino	Built	Building	Residential	2007	Asia











Appendix

Country	City	Period of history	image	Diagram	Main Relationship	Touches Ground
Sweden	Varberg	Contemporary			Separation	Ungrounded
Belgium	Wijgmaal	Contemporary			Adherence	Absence of level
Brazil	Rio Grande do Norte	Contemporary			Separation	Ungrounded
Chile	Aysén Region	Contemporary			Separation	Ungrounded
Germany	Munich	Contemporary			Adherence	Absence of level
United States of America	San Francisco	Contemporary			Interlock	Foundation
Australia	Yuulong	Contemporary			Adherence	Absence of level
Sweden	Mölle	Contemporary			Adherence	Absence of level
Brazil	Bragança Paulista	Contemporary			Adherence	Plinth
South Korea	Yecheon	Contemporary			Adherence	Absence of level
Switzerland	IFEC Consulenza	Contemporary			Adherence	Plinth

Appendix

ID	Architect Name	Building Name	Status	Type	Building Type	Year	Continent
262	Bernardo Bader Architekten	Haus am Stürcherwald	Built	Building	Residential	2017	Europe
263	Cadaval & Solà-Morales	MA House	Built	Building	Residential	2013	South America
264	Santiago Carlos Viale Lescano/Daniella Beviglia	La Rufina House	Built	Building	Residential	2013	South America
265	Camillo Botticini Architetto	Alps Villa	Built	Building	Residential	2012	Europe
266	YounghanChung + Studio Archiholic	9x9 Experimental House	Built	Building	Residential	2012	Asia
267	Walter Netsch, Skidmore, Owings and Merrill	Cadet Chapel	Built	Building	Public	1956	North America
268	Moisei Ginzburg	Narkomfin building	Built	Building	Public	1928	Europe
269	Jørn Utzon	Sydney Opera House	Built	Building	Public	1957	Oceania
270	AS+P	Criminal Court Complex	Built	Building	Public	2005	Asia
	Zaha Hadid	The Riverside Museum	Built	Building	Public	2011	Europe
	Zaha Hadid	Dubai Financial market	Unbuilt	Building	Public	2007	Asia

Appendix











Country	City	Period of history	image	Diagram	Main Relationship	Touches Ground
Austria	Latarns	Contemporary			Separation	Ungrounded
Mexico	Morelos	Contemporary			Adherence	Absence of level
Argentina	Córdoba	Contemporary			Separation	Ungrounded
Italy	Brescia	Contemporary			Interlock	Foundation
South Korea	Kyungki-do	Contemporary			Adherence	Absence of level
United States of America	Colorado	Postmodernism			Separation	Ungrounded
Russia	Moscow	Modernism			Separation	Ungrounded
Australia	Sydney	Postmodernism			Adherence	Plinth
Saudi Arabia	Riyadh	Contemporary			Interlock	Grounded
United Kingdom	Scotland	Contemporary			Adherence	Absence of level
United Arab Emirates	Dubai	Contemporary			Separation	Ungrounded

.7

Appendix

ID	Architect Name	Building Name	Status	Type	Building Type	Year	Continent
168	Zaha Hadid	Messner Mountain Museum Coronas	Built	Building	Public	2015	Europe
	Bjarke Ingels	KISTEFOS Museum of Modern Art	Unbuilt	Building	Public	2018	Europe
	BOONDESIGN	Blind House	Built	Building	Residential	2013	Asia
	BOONDESIGN	Raya Heritage Hotel	Built	Building	Public	2018	Asia
	David Chipperfield	Xixi Wetland Estate	Built	Building	Residential	2015	Asia
	Niko Architect	House in the Landscape	Built	Building	Residential	2019	Europe
	Dreissen and Jager Janssen architecten	Het Bosch Restaurant	Built	Building	Public	2010	Europe
	V+, Office Bouwtechniek	Town Hall in Montigny-le-Tilleul	Built	Building	Public	2013	Europe
	Farshad Mehdizadeh Architects	Termeh Office Commercial Building	Built	Building	Residential	2015	Asia
	Steven Chilton Architects	Wuxi TAIHU Show Theatre	Built	Building	Public	2019	Asia
134	Rudolph schindle	Harris house	Built	Building	Residential	1942	North America













Appendix

Country	City	Period of history	image	Diagram	Main Relationship	Touches Ground
Italy	Bolzano	Contemporary			Interlock	Grounded
Norway	Jevnaker	Contemporary			Separation	Ungrounded
Thailand	Bangkok	Contemporary			Interlock	Foundation
Thailand	Chiang Mai	Contemporary			Separation	Ungrounded
China	Hangzhou	Contemporary			Adherence	Absence of level
Russia	Moscow	Contemporary			Interlock	Grounded
Netherlands	Amsterdam	Contemporary			Separation	Ungrounded
Belgium	Montigny-Le-Tilleul	Contemporary			Separation	Ungrounded
Iran	Hamedan	Contemporary			Adherence	Absence of level
China	Wuxi	Contemporary			Adherence	Absence of level
United States of America	Los Angeles	Modernism			Interlock	Foundation

Appendix

ID	Architect Name	Building Name	Status	Type	Building Type	Year	Continent
135	Rudolph schindle	Wolfe House	Demolition	Building	Residential	1928	North America
136	Kengo Kuma	Kokohi bath house	Built	Structure	Public	2003	Asia
137	RCR architects	Rural Houses	Built	Building	Residential	2007	Europe
138	Ensamble Studio	Hemeroscopium House	Built	Building	Residential	2008	Europe
139	Pezo von Ellrichshausen	Solo Pezo Von Ellrichshausen	Built	Building	Residential	2013	Europe
140	Pezo von Ellrichshausen	Lopa House	Built	Building	Residential	2017	South America
141	SPASM Design Architects	The House Cast in Liquid Stone	Built	Building	Residential	2013	Asia
142	Malik Architecture	House of three streams	Built	Building	Residential	2016	Asia
143	Architecture BRIO	The Riparian House	Built	Building	Residential	2015	Asia
144	Kolman Boye Architects	Vega Cottage	Built	Building	Residential	2012	Europe
145	Jensen& Skodvin Architect	Summer House Storfjord	Built	Building	Residential	2013	Europe













Appendix

Country	City	Period of history	image	Diagram	Main Relationship	Touches Ground
United States of America	California	Modernism			Interlock	Foundation
Japan	Atami	Contemporary			Interlock	Foundation
Spain	Girona	Contemporary			Interlock	Foundation
Spain	Las Rozas	Contemporary			Separation	Ungrounded
Spain	Cretas	Contemporary			Separation	Ungrounded
Chile	Tome	Contemporary			Interlock	Foundation
India	Khopoli	Contemporary			Interlock	Foundation
India	Maharashtra	Contemporary			Interlock	Foundation
India	Karjat	Contemporary			Interlock	Foundation
Norway	Island of Vega	Contemporary			Interlock	Foundation
Norway	Storfjord	Contemporary			Separation	Ungrounded

Appendix

ID	Architect Name	Building Name	Status	Type	Building Type	Year	Continent
146	Carl-Viggo Hølmebakk	Concrete House	Built	Building	Residential	2014	Europe
147	BIO-architects	Bridge House	Built	Building	Residential	2018	Europe
148	Lucas Maino Fernandez	Guest House	Built	Building	Residential	2018	South America
149	Snohetta	Oslo Opera House	Built	Building	Public	2007	Europe
150	Camarim Arquitectos	House in Gateira	Built	Building	Residential	2014	Europe
151	Evolution Design	Flexhouse	Built	Building	Residential	2016	Europe
152	Renzo Piano	Centro Botín	Built	Building	Public	2017	Europe
153	Renzo Piano	Zentrum Paul Klee	Built	Building	Public	2005	Europe
154	Shigeru Ban Architects	Villa Vista	Built	Building	Residential	2010	Asia
155	Snohetta	Path of Perspectives Panorama Trail	Built	Structure	Public	2019	Europe
156	Snohetta	Outdoor Care Retreat	Built	Building	Residential	2018	Europe

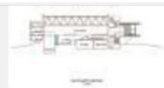











Appendix

Country	City	Period of history	image	Diagram	Main Relationship	Touches Ground
Norway	Stange	Contemporary			Adherence	Plinth
Russia	Zaokskiy	Contemporary			Separation	Ungrounded
Chile	Chonchi	Contemporary			Separation	Ungrounded
Norway	Oslo	Contemporary			Adherence	Plinth
Portugal	Portugal	Contemporary			Interlock	Foundation
Switzerland	Switzerland	Contemporary			Interlock	Foundation
Spain	Cantabria	Contemporary			Separation	Ungrounded
Switzerland	Bern	Contemporary			Interlock	Foundation
Sri Lanka	Weligama	Contemporary			Interlock	Foundation
Austria	Innsbruck	Contemporary			Interlock	Grounded
Norway	Oslo	Contemporary			Adherence	Absence of level

Appendix

ID	Architect Name	Building Name	Status	Type	Building Type	Year	Continent
157	Snohetta	Holmen Industrial Area	Built	Building	Public	2017	Europe
158	Snohetta	Lascaux IV	Built	Building	Public	2017	Europe
159	Snohetta	The 7th Room	Built	Building	Residential	2017	Europe
160	Snohetta	Eggum Tourist Route	Built	Building	Public	2007	Europe
161	Snohetta	Petter Dass Museum	Built	Building	Public	2007	Europe
162	Nicholas Plewman	Bisate Lodge	Built	Building	Residential	2018	Africa
102	Richard Neutra	Pescher House	Built	Building	Residential	1968	Europe
103	Richard Neutra	Rentsch House	Built	Building	Residential	1964	Europe
104	Richard Neutra	Josef Kun House	Built	Building	Residential	1936	North America
106	Superstudio	Continuous Monument	Unbuilt	Urban	Public	1969	Unlocated
107	Peter Eisenman	University Art Museum	Unbuilt	Urban	Public	1986	North America









Appendix

Country	City	Period of history	image	Diagram	Main Relationship	Touches Ground
Norway	Sortland Municipality	Contemporary			Separation	Ungrounded
France	Dordogne	Contemporary			Interlock	Foundation
Sweden	Harads	Contemporary			Separation	Ungrounded
Norway	Eggum	Contemporary			Interlock	Grounded
Norway	Alstahaug	Contemporary			Interlock	Grounded
Rwanda	Rwanda	Contemporary			Separation	Ungrounded
Germany	Wuppertal	Postmodernism			Adherence	Absence of level
Switzerland	Wengen	Postmodernism			Interlock	Foundation
United States of America	Los Angeles	Modernism			Interlock	Foundation
Unlocated	Unlocated	Postmodernism			Separation	Artificial Ground
United States of America	Long Beach	Postmodernism			Interlock	Grounded

Appendix

ID	Architect Name	Building Name	Status	Type	Building Type	Year	Continent
108	Peter Eisenman	Cannaregio Town Square	Unbuilt	Urban	Public	1978	Unlocated
109	Peter Eisenman	Parc de la Villette Competition	Unbuilt	Landscape	Public	1987	Unlocated
110	Peter Eisenman	Castelvecchio Museum Courtyard	Built	Landscape	Public	2003	Europe
111	Peter Eisenman	Memorial to the Murdered Jews of Europe	Built	Landscape	Public	2005	Europe
112	Peter Eisenman	City of Culture of Galicia	Built	Building	Public	2014	Europe
113	Rem Koolhaas, OMA	Exodus, or the Voluntary Prisoners of Architecture	Unbuilt	Urban	Public	1972	Europe
114	Rem Koolhaas, OMA	Seattle Central Library	Built	Building	Public	2004	North America
115	Walter Jonas	Intrapolis	Unbuilt	Urban	Public	1962	Unlocated
116	Tom Wiscombe	Rosatom Atomic Pavilion	Unbuilt	Building	Public	2015	Europe



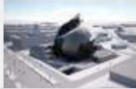







Appendix

Country	City	Period of history	image	Diagram	Main Relationship	Touches Ground
Unlocated	Unlocated	Postmodernism			Interlock	Foundation
Unlocated	Unlocated	Postmodernism			Interlock	Foundation
Italy	Verona	Contemporary			Interlock	Grounded
Germany	Berlin	Contemporary			Interlock	Grounded
Spain	Galicia	Contemporary			Interlock	Grounded
Germany	Berlin	Postmodernism			Separation	Artificial Ground
United States of America	Seattle (2004), Seattle, WA, OMA (2004), Seattle (2004), Seattle	Contemporary			Adherence	Absence of level
Unlocated	Unlocated	Postmodernism			Separation	Ungrounded
Russia	Moscow	Contemporary			Separation	Artificial Ground

Appendix

ID	Architect Name	Building Name	Status	Type	Building Type	Year	Continent
117	Tom Wiscombe	Guggenheim Helsinki	Unbuilt	Building	Public	2013	Europe
118	Tom Wiscombe	Powder Mountain House	Unbuilt	Building	Residential	2017	North America
119	Tom Wiscombe	Moscow Center for Contemporary Art	Unbuilt	Building	Public	2013	Europe
120	Tom Wiscombe	Lima Art Museum	Unbuilt	Building	Public	2015	South America
121	Tom Wiscombe	Collider Activity Center	Unbuilt	Building	Public	2012	Europe
122	P-A-T-T-E-R-N-S	Mapo Cultural Park	Unbuilt	Landscape	Public	2014	Asia
123	P-A-T-T-E-R-N-S	House of Hungarian Music	Unbuilt	Building	Public	2014	Europe
124	Rem Koolhaas, OMA	City of the Captive Globe	Unbuilt	Urban	Public	1972	North America
125	Will Alsop	Sharp Centre for Design	Built	Building	Public	2004	North America
126	Foreign Office Architect	Yokohama Port Terminal	Built	Building	Public	2002	Asia
127	Renzo Piano	Vulcano Bueno Shopping Centre	Built	Building	Public	2007	Europe













Appendix

Country	City	Period of history	image	Diagram	Main Relationship	Touches Ground
Finland	Helsinki	Contemporary			Separation	Artificial Ground
United States of America	Utah	Contemporary			Interlock	Foundation
Russia	Moscow	Contemporary			Separation	Artificial Ground
Peru	Lima	Contemporary			Interlock	Foundation
Bulgaria	Sofia	Contemporary			Separation	Artificial Ground
South Korea	Seoul	Contemporary			Interlock	Grounded
Hungary	Budapest	Contemporary			Interlock	Foundation
United States of America	New York	Postmodernism			Separation	Artificial Ground
Canada	Toronto	Contemporary			Separation	Ungrounded
Japan	Yokohama	Contemporary			Interlock	Grounded
Italy	Nola	Contemporary			Interlock	Grounded

Appendix

ID	Architect Name	Building Name	Status	Type	Building Type	Year	Continent
128	Renzo Piano	California Academy of Sciences	Built	Building	Public	2008	North America
129	Gluck+	Lakeside Retreat	Built	Building	Residential	2010	North America
130	Gluck+	House in the Mountains	Built	Building	Residential	2012	North America
131	Glenn Murcutt	Marika-Alderton House	Built	Building	Residential	1994	Oceania
132	Glenn Murcutt	Magney House	Built	Building	Residential	1984	Oceania
133	Paulo Mendes da Rocha	Brazilian Pavilion Osaka World Expo	Built	Structure	Public	1970	Asia
163	SANAA	Art Gallery of New South Wales	Unbuilt	Building	Public	2019	Oceania
164	Henning Larsen Architects	Viborg Town Hall	Built	Building	Public	2011	Europe
165	Rem Koolhaas, OMA	Maison Bordeaux	Built	Building	Residential	1998	Europe
166	Jean Nouvel	National Museum of Qatar	Built	Building	Public	2019	Asia
167	Zaha Hadid	Heydar Aliyev Center	Built	Building	Public	2013	Asia













Appendix

Country	City	Period of history	image	Diagram	Main Relationship	Touches Ground
United States of America	San Francisco	Contemporary			Adherence	Absence of level
United States of America	Adirondack	Contemporary			Interlock	Grounded
United States of America	Colorado	Contemporary			Adherence	Absence of level
Australia	Yirrkala	Postmodernism			Separation	Ungrounded
Australia	Moruya	Postmodernism			Adherence	Absence of level
Japan	Osaka	Postmodernism			Separation	Ungrounded
Australia	South Wales	Contemporary			Interlock	Foundation
Denmark	Viborg	Contemporary			Adherence	Absence of level
France	Bordeaux	Postmodernism			Separation	Ungrounded
Qatar	Doha	Contemporary			Interlock	Foundation
Azerbaijan	Baku	Contemporary			Interlock	Grounded

Appendix

ID	Architect Name	Building Name	Status	Type	Building Type	Year	Continent
	Skyland Architecture	Restaurant on the Cliff	Built	Building	Public	2018	Asia
	ADX	House in Itsuura	Built	Building	Residential	2014	Asia
	Battersby Howat Architects	Whistler Residence	Built	Building	Residential	2010	North America
	PAZ Arquitectura	Corallo House	Built	Building	Residential	2011	North America
	Gil Carlos de Camilo	Sebrae Bonito	Built	Building	Residential	2016	South America
	Mackay-Lyons Sweetapple Architects	Bridge House	Built	Building	Residential	2009	North America
	CROX	Liyang Museum	Built	Building	Public	2019	Asia
	Ark Encounter	LeRoy Troyer	Built	Building	Public	2016	North America
	Architectural Design Research Institute of SCUT	Three Ancestors Cultural Museum	Built	Building	Public	2015	Asia
	Studio Marco Vermeulen	Biesbosch Museum Island	Built	Building	Public	2015	Europe
	Lab Modus	Summit Housing Sales Center	Built	Building	Public	2011	Asia

















Appendix

Country	City	Period of history	image	Diagram	Main Relationship	Touches Ground
China	Handan	Contemporary			Interlock	Foundation
Japan	Kitaibaraki-Shi	Contemporary			Separation	Ungrounded
Canada	Whistler	Contemporary			Adherence	Absence of level
Guatemala	Guatemala City	Contemporary			Adherence	Absence of level
Brazil	Bonito	Contemporary			Interlock	Foundation
Canada	Nova Scotia	Contemporary			Interlock	Foundation
China	Changzhou	Contemporary			Interlock	Foundation
United States of America	Cincinnati	Contemporary			Separation	Ungrounded
China	Zhuo Lu	Contemporary			Adherence	Absence of level
Netherlands	Werkendam	Contemporary			Adherence	Plinth
Taiwan	Hsinchu	Contemporary			Adherence	Absence of level

Appendix

ID	Architect Name	Building Name	Status	Type	Building Type	Year	Continent
	El Dorado, Modus Studio	Sculpture Studio	Built	Building	Residential	2017	North America
	JAXDA	Miyuan Boutique Hotel	Built	Building	Public	2019	Asia
	TAO - Trace Architecture Office	Xiadi Paddy Field Bookstore of Librairie Avant-Garde	Built	Building	Public	2019	Asia
	Studio Lada	Nursing Home Extension	Built	Building	Public	2018	Europe
	Stemmer Rodrigues	Frame House	Built	Building	Residential	2018	South America
	AUÁ arquitetos	Laguna House	Built	Building	Residential	2018	South America
	Evolution Design	Yard under the Tree	Built	Building	Residential	2019	Asia
	Studio CK Arqitetura	Serena House	Built	Building	Residential	2019	South America
	Santiago Calatrava	Palau de les Arts Reina Sofia	Built	Building	Public	2006	Europe
	Architekturbüro Steidl	Medium Voltage Grid Control Center	Built	Building	Public	2015	Europe
	Ahlbrecht Felix Scheidt Kasprusch	St Antony Industrial Archaeological Park	Built	Structure	Public	2011	Europe













Appendix

Country	City	Period of history	image	Diagram	Main Relationship	Touches Ground
United States of America	Fayette ville	Contemporary			Adherence	Plinth
China	Xuancheng	Contemporary			Separation	Ungrounded
China	Ningde	Contemporary			Interlock	Foundation
France	Vaucoulers	Contemporary			Interlock	Foundation
Brazil	Novo Hamburg	Contemporary			Separation	Artificial Ground
Brazil	Botucatu	Contemporary			Interlock	Foundation
China	Beijing	Contemporary			Interlock	Foundation
Brazil		Contemporary			Interlock	Foundation
Spain	Valencia	Contemporary			Adherence	Absence of level
Germany	Neunmurg Vorm Wald	Contemporary			Separation	Ungrounded
Germany	Oberhausen	Contemporary			Interlock	Foundation

Appendix

ID	Architect Name	Building Name	Status	Type	Building Type	Year	Continent
	Zaha Hadid	Bergisel Ski Jump	Built	Building	Public	2002	Oceania
	Alexis Dornier	Lift Treetop Boutique Hotel	Built	Building	Public	2018	Asia
	Nomadic Resorts	Wild Coast Tented Lodge	Built	Building	Public	2017	Asia
	DAS Lab	Lost Villa Boutique Hotel	Built	Building	Public	2019	Asia
58	Santiago Calatrava	Bac de Roda Bridge	Built	Structure	Public	1987	Europe
59	Santiago Calatrava	Alameda Bridge and Metro Station	Built	Structure	Public	1995	Europe
60	Santiago Calatrava	Puente del Alamillo	Built	Structure	Public	1992	Europe
61	Santiago Calatrava	Crown Prince Bridge	Built	Structure	Public	1994	Europe
62	Santiago Calatrava	Trinity Bridge, Greater Manchester	Built	Structure	Public	1995	Europe
63	Santiago Calatrava	Women's Bridge	Built	Structure	Public	2001	South America
64	Santiago Calatrava	Bodegas Ysios	Built	Building	Public	2001	Europe











Appendix

Country	City	Period of history	image	Diagram	Main Relationship	Touches Ground
Austria	Innsbruck	Contemporary			Interlock	Grounded
Indonesia	Kecamatn Ubud	Contemporary			Separation	Ungrounded
Sri Lanka	Palatupana	Contemporary			Separation	Ungrounded
China	Zhongwei	Contemporary			Interlock	Foundation
Spain	Barcelona	Postmodernism			Separation	Ungrounded
Spain	Valencia	Postmodernism			Separation	Ungrounded
Spain	Seville	Postmodernism			Separation	Ungrounded
Germany	Berlin	Postmodernism			Separation	Ungrounded
United Kingdom	Manchester	Postmodernism			Separation	Ungrounded
Argentina	Buenos Aires	Contemporary			Separation	Ungrounded
Spain	Laguardia	Contemporary			Adherence	Absence of level

Appendix

ID	Architect Name	Building Name	Status	Type	Building Type	Year	Continent
65	Santiago Calatrava	Chords Bridge	Built	Structure	Public	2008	Asia
66	Santiago Calatrava	Constitution Bridge	Built	Structure	Public	2008	Europe
67	Santiago Calatrava	Palace of Exhibitions and Congresses City	Built	Building	Public	2011	Europe
68	Santiago Calatrava	Peace Bridge	Built	Structure	Public	2011	Europe
69	Tadao Ando	Chichu Art Museum	Built	Building	Public	2004	Asia
70	Tadao Ando	Hyogo Prefectural Museum Of Art	Built	Building	Public	2002	Asia
71	Tadao Ando	Fort Worth Museum of Modern Art	Built	Building	Public	2002	North America
72	Tadao Ando	Stepped gardens of Awaji Yumebutai	Built	Structure	Public	1995	Asia
73	Tadao Ando	Osaka Prefectural Chikatsu Asuka Museum	Built	Building	Public	1994	Asia
74	Tadao Ando	Shikoku Mura gallery	Built	Building	Public	2002	Asia
75	Tadao Ando	Nagaragawa Convention Center	Built	Building	Public	1995	Asia













Appendix

Country	City	Period of history	image	Diagram	Main Relationship	Touches Ground
Palestine	Jerusalem	Contemporary			Separation	Ungrounded
Italy	Venice	Contemporary			Separation	Ungrounded
Spain	Oviedo	Contemporary			Adherence	Absence of level
Spain	Asturias	Contemporary			Separation	Ungrounded
Japan	Kagawa	Contemporary			Interlock	Grounded
Japan	Kobe	Contemporary			Interlock	Foundation
United States of America	Fort Worth	Contemporary			Adherence	Absence of level
Japan	Awaji	Contemporary			Interlock	Foundation
Japan	Osaka	Contemporary			Interlock	Foundation
Japan	Yashima	Contemporary			Interlock	Foundation
Japan	Gifu Prefecture	Contemporary			Adherence	Absence of level

Appendix

ID	Architect Name	Building Name	Status	Type	Building Type	Year	Continent
76	Tadao Ando	Rokko Residential Conjunction	Built	Building	Residential	1998	Asia
77	Steven Holl	Y House	Built	Building	Residential	1999	North America
78	Steven Holl	Nelson-Atkins Museum of Art (Addition)	Built	Building	Public	2007	North America
79	Philip Johnson	Glass House	Built	Building	Residential	1949	North America
80	Ludwing Mies Van der Rohe	IIT Chapel "Godbox"	Built	Building	Public	1952	North America
81	Adalberto Libera	Casa Malaparte	Built	Building	Residential	1937	Europe
82	Lina Bo Bardi	Museum of Modern Art	Built	Building	Public	1968	South America
83	Gordon Bunshaft	Beinecke Rare Book & Manuscript Library	Built	Building	Public	1963	North America
84	Herzog & De Meuron	Rudin House	Built	Building	Residential	1997	Europe
85	Ludwing Mies Van der Rohe	Neue Nationalgalerie	Built	Building	Public	1968	Europe
86	Rem Koolhaas, OMA	Casa de Musica	Built	Building	Public	2005	Europe













Appendix

Country	City	Period of history	image	Diagram	Main Relationship	Touches Ground
Japan	Kobe	Contemporary			Interlock	Grounded
United States of America	Catskill	Contemporary			Adherence	Absence of level
United States of America	Kansas City	Contemporary			Interlock	Foundation
United States of America	New Canaan	Modernism			Adherence	Absence of level
United States of America	Chicago	Postmodernism			Adherence	Absence of level
Italy	Isle of Capri	Modernism			Interlock	Foundation
Brazil	São Paulo	Postmodernism			Separation	Ungrounded
United States of America	New Haven	Postmodernism			Separation	Ungrounded
France	Leyman	Contemporary			Separation	Ungrounded
Germany	Berlin	Postmodernism			Adherence	Plinth
Portugal	Porto	Contemporary			Separation	Artificial Ground

Appendix

ID	Architect Name	Building Name	Status	Type	Building Type	Year	Continent
87	Thomas Heatherwick	Seed Cathedral	Built	Building	Public	2010	Asia
88	Neil Denari	TROIA	Built	Building	Public	2005	Unlocated
89	NL Architects	Amethyst Hotel	Unbuilt	Building	Public	2015	Asia
90	kengo kuma	Great bamboo wall house	Built	Building	Residential	2002	Asia
91	Douglas Darden	Oxygen House	Unbuilt	Building	Residential	1988	North America
92	Peter Eisenman	Max Reinhardt Haus	Unbuilt	Building	Public	1993	Europe
93	Herzog & De Meuron	Goetz Gallery	Built	Building	Public	1990	Europe
94	Marcel Breuer	Whitney museum of american art	Built	Building	Public	1966	North America
95	Ludwing Mies Van der Rohe	Bacardi Administrative Building	Built	Building	Public	1961	South America
96	Ludwing Mies Van der Rohe	Alumni Memorial Hall	Built	Building	Public	1946	North America
97	Ludwing Mies Van der Rohe	Brick Country House	Unbuilt	Building	Residential	1924	Unlocated

















Appendix

Country	City	Period of history	image	Diagram	Main Relationship	Touches Ground
China	Shanghai	Contemporary			Separation	Artificial Ground
Unlocated	Unlocated	Contemporary			Separation	Ungrounded
China	South coast	Contemporary			Interlock	Grounded
China	Beijing	Contemporary			Interlock	Foundation
United States of America	Mississippi	Postmodernism			Interlock	Foundation
Germany	Berlin	Contemporary			Interlock	Foundation
Germany	Munich	Contemporary			Interlock	Foundation
United States of America	New York	Postmodernism			Interlock	Foundation
Mexico	Mexico City	Postmodernism			Separation	Ungrounded
United States of America	Chicago	Modernism			Adherence	Absence of level
Unlocated	Unlocated	Modernism			Adherence	Absence of level

Appendix

ID	Architect Name	Building Name	Status	Type	Building Type	Year	Continent
98	Ludwing Mies Van der Rohe	Lake Shore Drive Apartments	Built	Building	Residential	1951	North America
99	Ludwing Mies Van der Rohe	Westmount Square	Built	Building	Public	1967	North America
100	Ludwing Mies Van der Rohe	Chicago Federal Center	Built	Building	Public	1974	North America
101	Richard Neutra	Pitcairn House	Built	Building	Residential	1962	North America
	Lemaymichaud Architecture	Strøm Spa Vieux-Québec	Built	Building	Public	2018	North America
	Viero Arquitetura	360 Poa Gastrobar	Built	Building	Public	2018	South America
	Tacoa Arqitetos	Galeria Adriana Varejao	Built	Building	Public	2008	South America
	Gyung Sung Architects	G-Tower	Built	Building	Public	2013	Asia
	New Wave Architecture	Mosha House	Built	Building	Residential	2016	Asia
	Heatherwick Studio	Learning Hub	Built	Building	Public	2015	Asia
	Coop Himmelb(l)au	Busan Cinema Center	Built	Building	Public	2012	Asia

















Appendix

Country	City	Period of history	image	Diagram	Main Relationship	Touches Ground
United States of America	Chicago	Postmodernism			Separation	Ungrounded
Canada	Montreal	Postmodernism			Separation	Column on Plinth
United States of America	Chicago	Postmodernism			Separation	Ungrounded
United States of America	Pennsylvania	Postmodernism			Interlock	Foundation
Canada	Quebec	Contemporary			Interlock	Foundation
Brazil	Porto Alegre	Contemporary			Separation	Ungrounded
Brazil	Brumadinho	Contemporary			Interlock	Foundation
South Korea	Incheon	Contemporary			Adherence	Absence of level
Iran	Mosha	Contemporary			Interlock	Foundation
Singapore	Singapore	Contemporary			Separation	Column on Plinth
South Korea	Busan	Contemporary			Separation	Ungrounded

Appendix

ID	Architect Name	Building Name	Status	Type	Building Type	Year	Continent
	Mass Studies	Songwon Art Center	Built	Building	Public	2012	Asia
	AK2	RELAXX sport and leisure center	Built	Building	Public	2008	Europe
	Archier Studio	SawMill House	Built	Building	Residential	2014	Oceania
	DIALOG	Southlands Residence	Built	Building	Residential	2011	North America
	Walker Workshop	Oak Pass Main House	Built	Building	Residential	2015	North America
	John Pardey Architects	Cheeran House	Built	Building	Residential	2015	Europe
	Andramatin	IH Residence	Built	Building	Residential	2015	Asia
	Feldman Architecture	MILL VALLEY	Built	Building	Residential	2010	North America
	PPA	Extension Of A Barn	Built	Building	Residential	2010	Europe
	Feldman Architecture	House Ocho	Built	Building	Residential	2004	North America
	Feldman Architecture	Butterfly House	Built	Building	Residential	2015	North America











Appendix

Country	City	Period of history	image	Diagram	Main Relationship	Touches Ground
South Korea	Seoul	Contemporary			Interlock	Foundation
Slovakia	Bratislava	Contemporary			Separation	Ungrounded
Austria	Yackandandah	Contemporary			Adherence	Absence of level
Canada	Vancouver	Contemporary			Separation	Ungrounded
United States of America	Beverly Hills	Contemporary			Interlock	Grounded
United Kingdom	Lower Basildon	Contemporary			Adherence	Absence of level
Indonesia	Bandug	Contemporary			Interlock	Foundation
United States of America	California	Contemporary			Interlock	Foundation
France	Toulouse	Contemporary			Interlock	Grounded
United States of America	Carmel By the Sea	Contemporary			Interlock	Foundation
United States of America	Carmel By the Sea	Contemporary			Adherence	Absence of level

Appendix

ID	Architect Name	Building Name	Status	Type	Building Type	Year	Continent
	Bercy Chen Studio	Shore Vista Boat Dock	Built	Building	Residential	2011	North America
	Design Work Group	Jetwan House	Built	Building	Residential	2016	Asia
	Feldman Architecture	Sunrise Pavilion	Built	Building	Residential	2016	North America
	Feldman Architecture	The Pavilion	Built	Building	Residential	2018	North America
	Feldman Architecture	The Sanctuary House	Built	Building	Residential	2019	North America
	Feldman Architecture	Tierwelthaus House	Built	Building	Residential	2018	North America
	Mork-Ulnes Architects	Skigard Hytte Cabin	Built	Building	Residential	2019	Europe
	Mork-Ulnes Architects	Artist Studio in Sonoma	Built	Building	Residential	2015	North America
	Mork-Ulnes Architects	Mylla Hytte	Built	Building	Residential	2017	Europe
	Mork-Ulnes Architects	Moose Road	Built	Building	Residential	2013	North America
	Mork-Ulnes Architects	Troll Hus	Built	Building	Residential	2016	North America











Appendix

Country	City	Period of history	image	Diagram	Main Relationship	Touches Ground
United States of America	Austin	Contemporary			Separation	Ungrounded
India	Surat	Contemporary			Adherence	Absence of level
United States of America	Healdsburg	Contemporary			Adherence	Plinth
United States of America	San Jose SAN JOSÉ	Contemporary			Adherence	Plinth
United States of America	Palo Alto	Contemporary			Adherence	Plinth
United States of America	Portola valley	Contemporary			Adherence	Absence of level
Norway	Kvitfjell	Contemporary			Separation	Ungrounded
United States of America	Sebastopol	Contemporary			Adherence	Absence of level
Norway	Nordmarka	Contemporary			Adherence	Absence of level
United States of America	Ukiah	Contemporary			Separation	Ungrounded
United States of America	California	Contemporary			Separation	Ungrounded

Appendix

ID	Architect Name	Building Name	Status	Type	Building Type	Year	Continent
	Mork-Ulnes Architects	20th St.	Built	Building	Residential	2011	North America
	Mork-Ulnes Architects	Ridge House	Built	Building	Residential	2018	North America
	Qarta Architektura	New Lecture Center VŠPJ	Built	Building	Public	2019	Europe
	Qarta Architektura	The Origami Project	Built	Building	Residential	2015	Europe
	Bates Masi	Beach Hampton	Built	Building	Residential	2014	North America
	Olson Kundig	Blakely Island Artist Studio	Built	Building	Residential	2014	North America
	Olson Kundig	Northwoods House	Built	Building	Residential	2010	North America
	Olson Kundig	Capital House	Built	Building	Residential	2008	North America
	Olson Kundig	Tofino Beach House	Built	Building	Residential	2016	North America
	Olson Kundig	Wave House	Built	Building	Residential	2018	North America
	Olson Kundig	Whistler Ski House	Built	Building	Residential	2014	North America











Appendix

Country	City	Period of history	image	Diagram	Main Relationship	Touches Ground
United States of America	San Francisco	Contemporary			Adherence	Absence of level
United States of America	California	Contemporary			Separation	Ungrounded
Czech Republic	Jihlava	Contemporary			Adherence	Absence of level
Czech Republic	Prague Prague Prague Prague	Contemporary			Adherence	Absence of level
United States of America	Amagansett	Contemporary			Interlock	Foundation
United States of America	san juan islands	Contemporary			Interlock	Foundation
United States of America	Michigan Iron River	Contemporary			Interlock	Foundation
United States of America	Washington	Contemporary			Adherence	Absence of level
Canada	Tofino TOFINO, CANADA TOFINO	Contemporary			Interlock	Foundation
United States of America	Mercer Island	Contemporary			Interlock	Foundation
Canada	Whistler	Contemporary			Separation	Ungrounded

Appendix

ID	Architect Name	Building Name	Status	Type	Building Type	Year	Continent
	Bates Masi	Northwest Harbor	Built	Building	Residential	2013	North America
	Bates Masi	Georgica Close	Built	Building	Residential	2016	North America
	Bates Masi	Georgica Cove	Built	Building	Residential	2017	North America
	Bates Masi	Promised Land	Built	Building	Residential	2015	North America
	Bates Masi	Underhill	Built	Building	Residential	2015	North America
	Bates Masi	Atlantic	Built	Building	Residential	2016	North America
	Bates Masi	Amagansett Dunes	Built	Building	Residential	2015	North America
	Bates Masi	Elizabeth II	Built	Building	Residential	2014	North America
	Bates Masi	Mothersill	Built	Building	Residential	2013	North America
	Bates Masi	Far Pond	Built	Building	Residential	1970	North America
	Bates Masi	Sagaponack	Built	Building	Residential	2013	North America











Appendix

Country	City	Period of history	image	Diagram	Main Relationship	Touches Ground
United States of America	East Hampton	Contemporary			Separation	Ungrounded
United States of America	East Hampton	Contemporary			Adherence	Plinth
United States of America	East Hampton	Contemporary			Adherence	Plinth
United States of America	Amagansett	Contemporary			Interlock	Foundation
United States of America	Matinecock	Contemporary			Adherence	Absence of level
United States of America	Amagansett	Contemporary			Adherence	Plinth
United States of America	Amagansett	Contemporary			Adherence	Absence of level
United States of America	Amagansett	Contemporary			Adherence	Absence of level
United States of America	Water Mill	Contemporary			Interlock	Foundation
United States of America	New York	Postmodernism			Adherence	Absence of level
United States of America	Sagaponack	Contemporary			Adherence	Plinth

Appendix

ID	Architect Name	Building Name	Status	Type	Building Type	Year	Continent
	Robert Venturi	Vanna Venturi House	Built	Building	Residential	1964	North America
	Robert Venturi	Sainsbury Wing	Built	Building	Public	1991	Europe
	Domenack arquitectos	P2 House Poseidon	Built	Building	Residential	2013	South America
	Domenack Arquitectos	M+L House	Built	Building	Residential	2016	South America
	Domenack Arquitectos	S House	Built	Building	Residential	2009	South America
	Domenack Arquitectos	B House	Built	Building	Residential	2008	South America
	Paola Calzada Arquitectos	Casa Lomas II	Built	Building	Residential	2013	North America
	Anf Arquitectos	Arqwa House	Built	Building	Residential	2015	Europe
	Andres Nuñez Fuenzalida Arquitectos	M House	Built	Building	Residential	2016	Europe
	Andres Nuñez Fuenzalida Arquitectos	U House	Built	Building	Residential	2018	Europe
	Cadas Arqitetura	Itanhangá House	Built	Building	Residential	2016	South America











Appendix

Country	City	Period of history	image	Diagram	Main Relationship	Touches Ground
United States of America	Pennsylvania	Postmodernism			Adherence	Absence of level
United Kingdom	London	Postmodernism			Adherence	Absence of level
PERU	Pucusana	Contemporary			Interlock	Foundation
PERU	Miraflores	Contemporary			Adherence	Absence of level
PERU	Lima	Contemporary			Adherence	Absence of level
PERU	Lima	Contemporary			Adherence	Absence of level
Mexico	Mexico City	Contemporary			Interlock	Foundation
Chile	Lago Ranco	Contemporary			Separation	Ungrounded
Chile	Cachagua	Contemporary			Adherence	Absence of level
Chile	Santiago	Contemporary			Adherence	Absence of level
Brazil	Itanhangá	Contemporary			Interlock	Foundation

Appendix

ID	Architect Name	Building Name	Status	Type	Building Type	Year	Continent
	Garza Maya Arquitectos	MV House	Built	Building	Residential	2019	North America
	Shevi Loewinger + Ravit Kaplan	Loewinger Residence	Built	Building	Residential	2016	North America
	Birdseye Design	Mural House	Built	Building	Residential	2019	North America
	Studio NAOM	Noto-Lucchesi Stadium	Built	Building	Public	2016	Europe
	Alarcón + Asociados	House at León	Built	Building	Residential	2009	Europe
	Alarcón + Asociados	Logytel I+D	Built	Building	Public	2012	Europe
	odd	OdD House 1.0	Built	Building	Residential	2015	South America
	odd	Aranya Café	Built	Building	Public	2018	Asia
	NPDA studio	Somjai House	Built	Building	Residential	2015	Asia
	NPDA Studio	Prachasongkroa Kindergarden School	Built	Building	Public	2013	Asia
	NPDA Studio	Bunjob House	Built	Building	Residential	2018	Asia











Appendix

Country	City	Period of history	image	Diagram	Main Relationship	Touches Ground
Mexico	Chihuahua	Contemporary			Adherence	Absence of level
United States of America	Guerneville	Contemporary			Separation	Artificial Ground
United States of America	Burlington	Contemporary			Interlock	Foundation
France	Marseille	Contemporary			Interlock	Grounded
Spain	León	Contemporary			Interlock	Foundation
Spain	Alcala de Henares	Contemporary			Interlock	Foundation
Ecuador	Quito	Contemporary			Adherence	Plinth
China	Beidaihe	Contemporary			Adherence	Plinth
Thailand	Ko Pha Ngan	Contemporary			Adherence	Plinth
Thailand	Kanchanaburi	Contemporary			Adherence	Absence of level
Thailand	Ko Pha Ngan	Contemporary			Adherence	Plinth

Appendix

ID	Architect Name	Building Name	Status	Type	Building Type	Year	Continent
	Santos Bolívar	Media Perra House	Built	Building	Public	2017	North America
	Santos Bolívar	Bed & Breakfast Santulan	Built	Building	Public	2019	North America
	Santos Bolívar	Media Perra Brewery	Built	Building	Public	2016	North America
	RSAAW	Copper Spirit Distillery	Built	Building	Public	2019	North America
	Dellekamp Arquitectos	L House	Built	Building	Residential	2018	North America
	Mabire Reich	Landscape House	Built	Building	Residential	2015	Europe
	North Arrow Studio	RoadRunner Residence	Built	Building	Residential	2014	North America
	LTD Architectural Design Studio	Back Country House	Built	Building	Residential	2016	Oceania
	Strom Architects	The Quest	Built	Building	Residential	2015	Europe
	Strom Architects	Woodpeckers	Built	Building	Residential	2015	Europe
	Strom Architects	Hartrow	Built	Building	Residential	2014	Europe











Appendix

Country	City	Period of history	image	Diagram	Main Relationship	Touches Ground
Mexico	Guadalupe	Contemporary			Separation	Ungrounded
Mexico	Valle de Guadalupe	Contemporary			Separation	Ungrounded
Mexico	Villa de Juárez	Contemporary			Adherence	Absence of level
Canada	Bowen Island	Contemporary			Adherence	Absence of level
Mexico	Valle de Bravo	Contemporary			Interlock	Foundation
France	Nantes	Contemporary			Adherence	Absence of level
United States of America	Austin	Contemporary			Separation	Ungrounded
New Zealand	Puhoi	Contemporary			Adherence	Plinth
United Kingdom	Swanage	Contemporary			Adherence	Absence of level
United Kingdom	New Forest District	Contemporary			Adherence	Absence of level
United Kingdom	Winchester	Contemporary			Interlock	Foundation

Appendix

ID	Architect Name	Building Name	Status	Type	Building Type	Year	Continent
	Strom Architects + John Pardey Architects	Hurst House	Built	Building	Residential	2012	Europe
	JJRR/Arquitectura + Area	Vertientes House	Built	Building	Residential	2018	North America
	JJRR/Arquitectura + Area	Ramos House	Built	Building	Residential	2017	North America
	JJRR/Arquitectura + Area	Caúcaso House	Built	Building	Residential	2016	North America
	JJRR/Arquitectura + Area	Casa Sierra Leona	Built	Building	Residential	2014	North America
	John Pardey Architects	Hind House	Built	Building	Residential	2008	Europe
	Studio Lada	Open Source House	Built	Building	Residential	2016	Europe
	Swedish firm Manofactory	Nestinbox Nestinbox Nestinbox Nestinbox	Unbuilt	Building	Residential	2016	Europe
	Mackay-Lyons Sweetapple Architects	Muir Craig house	Built	Building	Residential	2017	North America
	Mackay-Lyons Sweetapple Architects	Lean-to House	Built	Building	Residential	2013	North America











Appendix

Country	City	Period of history	image	Diagram	Main Relationship	Touches Ground
United Kingdom	Bourne End	Contemporary			Adherence	Absence of level
Mexico	Ciudad de México	Contemporary			Adherence	Absence of level
Mexico	Ciudad de México	Contemporary			Adherence	Absence of level
Mexico	Ciudad de México	Contemporary			Separation	Ungrounded
Mexico	Mexico City	Contemporary			Adherence	Absence of level
United Kingdom	Reading	Contemporary			Separation	Ungrounded
France	Baccarat	Contemporary			Adherence	Plinth
Sweden	NA	Contemporary			Interlock	Foundation
Canada	Nova Scotia	Contemporary			Adherence	Plinth
Canada	Nova Scotia	Contemporary			Separation	Ungrounded

Appendix

ID	Architect Name	Building Name	Status	Type	Building Type	Year	Continent
	Mackay-Lyons Sweetapple Architects	Sliding House	Built	Building	Residential	2013	North America
	Mackay-Lyons Sweetapple Architects	Golden Grove Shed	Built	Building	Public	2013	North America
	Mackay-Lyons Sweetapple Architects	Box House	Built	Building	Residential	2014	North America
	Mackay-Lyons Sweetapple Architects	Shapiro Barn	Built	Building	Residential	2013	North America
	Mackay-Lyons Sweetapple Architects	Royal Bank Pubnico	Built	Building	Public	1998	North America
	Mackay-Lyons Sweetapple Architects	Computer Science Building Dalhousie University	Built	Building	Public	1999	North America
	Dominic Stevens Architects	Mimetic House	Built	Building	Residential	2007	Europe
	Thomas P. Murphy Design Studio	University of Miami School of Architecture	Built	Building	Public	2018	North America
	Huttunen-Lipasti-Pakkanen Architects	Villa Mecklin	Built	Building	Residential	2008	Europe
	Travis Price Architects	Hayes Residence	Built	Building	Residential	2014	North America











Appendix

Country	City	Period of history	image	Diagram	Main Relationship	Touches Ground
Canada	NA	Contemporary			Adherence	Absence of level
Canada	NA	Contemporary			Adherence	Absence of level
Canada	NA	Contemporary			Adherence	Absence of level
Canada	NA	Contemporary			Interlock	Foundation
Canada	Lieutenant	Postmodernism			Adherence	Absence of level
Canada	Lieutenant	Postmodernism			Adherence	Absence of level
Ireland	Leitrim	Contemporary			Interlock	Foundation
United States of America	Miami	Contemporary			Adherence	Absence of level
Finland	Naantali	Contemporary			Separation	Ungrounded
United States of America	Virginia	Contemporary			Separation	Ungrounded

Appendix

ID	Architect Name	Building Name	Status	Type	Building Type	Year	Continent
	SsD	Songpa Micro-Housing	Built	Building	Residential	2014	Asia
	Bjarke Ingels	Musee Atelier Audemars Piguet	Built	Building	Public	2020	Europe
	Fran Silvestre Architects	House of th Sun	Unbuilt	Building	Residential	2020	Europe
	Fran Silvestre Architects	House of Silence	Built	Building	Residential	2020	Europe
	Eero Saarinen	Milwaukee County War Memorial	Built	Building	Public	1957	North America
	STC Architects	Refuge in Cordoba	Built	Building	Residential	2020	South America
	William Kaven Architecture	Royal	Built	Building	Residential	2020	North America
	HANNAH	Ashen Cabin	Built	Building	Residential	2019	North America
	EYP Architecture & Engineering	College of William & Mary, The Mcleod Tyler	Built	Building	Public	2018	North America
	Stefan Schweighofer	FH Kaltenbrunnen	Built	Building	Public	2019	Oceania
	Valerie Schweitzer Architects	Outside-in Pavilion	Built	Building	Residential	2020	North America











Appendix

Country	City	Period of history	image	Diagram	Main Relationship	Touches Ground
South Korea	Seoul	Contemporary			Separation	Ungrounded
Switzerland	Le Chenit	Contemporary			Interlock	Grounded
Spain	Marbella	Contemporary			Interlock	Foundation
Spain	NA	Contemporary			Adherence	Absence of level
United States of America	Milwaukee	Postmodernism			Separation	Column on Plinth
Argentina	Villa Serranita	Contemporary			Separation	Ungrounded
United States of America	Portland	Contemporary			Interlock	Foundation
United States of America	New York	Contemporary			Separation	Ungrounded
United States of America	Williamsburg	Contemporary			Adherence	Plinth
Austria	Egg	Contemporary			Interlock	Foundation
United States of America	New York	Contemporary			Separation	Ungrounded

Appendix

ID	Architect Name	Building Name	Status	Type	Building Type	Year	Continent
	Cobe	Orientkaj and Nordhavn Metro Stations	Built	Building	Public	2020	Europe
	noa network of architecture	Biwak	Unbuilt	Building	Public	2020	Europe
	noa network of architecture	Reaching the peak	Built	Building	Public	2020	Europe
	Design Work Group	Brick Curtain House	Built	Building	Residential	2016	Asia
	L'agence KARAWITZ	The Marly House	Built	Building	Residential	2015	Europe
	JADE + Quarry Associates	InterContinental Shanghai Wonderland	Built	Building	Public	2009	Asia
	Zegnea Grupo	Creche	Built	Building	Public	2020	Europe
	Eero Saarinen	Miller House	Built	Building	Residential	1953	North America
	Bernard Zimmerman	Zeidler Residence	Built	Building	Residential	1961	North America
	Plan:b arquitectos	Rio Cedro House	Built	Building	Residential	2011	South America
	IBUKU	Sharma Springs	Built	Building	Residential	2012	Asia











Appendix

Country	City	Period of history	image	Diagram	Main Relationship	Touches Ground
Denmark	Copenhagen	Contemporary			Separation	Ungrounded
Italy	Schnalstal glacier	Contemporary			Interlock	Grounded
Italy	South Tyrol	Contemporary			Separation	Ungrounded
India	Surat	Contemporary			Separation	Ungrounded
France		Contemporary			Separation	Ungrounded
China	Shanghai	Contemporary			Interlock	Grounded
Portugal	Braga	Contemporary			Adherence	Absence of level
United States of America	Indiana	Postmodernism			Adherence	Plinth
United States of America	Los Angeles	Postmodernism			Separation	Ungrounded
Colombia	Monitos	Contemporary			Separation	Ungrounded
Indonesia	Abiansemal	Contemporary			Separation	Ungrounded

Appendix

ID	Architect Name	Building Name	Status	Type	Building Type	Year	Continent
	IBUKU	The Green School	Built	Building	Public	2009	Asia
	BUERO BECHTLOFF	New Build Villa	Built	Building	Residential	2019	Europe
	José Carlos Cruz	House in Foz do Douro II	Built	Building	Residential	2010	Europe
	SAOTA	Invermark House	Built	Building	Residential	2015	Africa
	SAOTA	Beachyhead	Built	Building	Residential	2014	Africa
	ARRCC + SAOTA	Lake House	Built	Building	Residential	2018	Europe
	Gerrit Rietveld	Schroder House	Built	Building	Residential	1924	Europe
	White Cube Atelier	Gray Villa	Built	Building	Residential	2020	Asia
	Takeshi Hirobe Architects	Villa Escargot	Built	Building	Residential	2014	Asia
	Takeshi Hirobe Architects	Villa SSK	Built	Building	Residential	2012	Asia
	Takeshi Hirobe Architects	Seashore Shell House	Built	Building	Residential	2008	Asia











Appendix

Country	City	Period of history	image	Diagram	Main Relationship	Touches Ground
Indonesia	Bali	Contemporary			Separation	Column on Plinth
Germany	Aumühle	Contemporary			Interlock	Foundation
Portugal	Porto	Contemporary			Adherence	Plinth
South Africa	Cape Town	Contemporary			Adherence	Plinth
South Africa	Plettenberg Bay	Contemporary			Interlock	Foundation
Switzerland	Geneva	Contemporary			Adherence	Absence of level
Netherlands	Utrecht	Modernism			Adherence	Absence of level
Iran	Maku	Contemporary			Interlock	Foundation
Japan	Chiba	Contemporary			Adherence	Absence of level
Japan	Chiba	Contemporary			Adherence	Plinth
Japan	Chiba	Contemporary			Adherence	Plinth

Appendix

ID	Architect Name	Building Name	Status	Type	Building Type	Year	Continent
	staffan berglund	villa spies	Built	Building	Residential	1969	Europe
	Paul Rudolph	Milam Residence	Built	Building	Residential	1962	North America
	Mathias Klotz	Casa Once Mujeres	Built	Building	Residential	2007	Europe
	Mathias Klotz	Casa Klotz	Built	Building	Residential	1991	Europe
	Carlo Scarpa	Villa Ottolenghi	Built	Building	Residential	1978	Europe
	Edwin Lutyens	Goddards	Built	Building	Residential	1900	Europe
	Edward Prior	Voewood/Home Place	Built	Building	Residential	1905	Europe
	Greene&Greene	The Gamble House	Built	Building	Residential	1908	North America
	Rudolph Schindler	Schindler House	Built	Building	Residential	1922	North America
	Eliel Saarinen	Saarinen House	Built	Building	Residential	1930	North America
	Arine Jacobsen	Rothenborg House	Built	Building	Residential	1931	Europe











Appendix

Country	City	Period of history	image	Diagram	Main Relationship	Touches Ground
Sweden	Toro	Modernism			Interlock	Foundation
United States of America	Florida	Modernism			Adherence	Absence of level
Chile	Zapallar	Contemporary			Interlock	Foundation
Chile	Tongoy	Contemporary			Adherence	Absence of level
Italy	Bardolino	Postmodernism			Interlock	Foundation
United Kingdom	England	Modernism			Adherence	Plinth
United Kingdom	England	Modernism			Adherence	Plinth
United States of America	Pasadena	Modernism			Adherence	Plinth
United States of America	Los Angeles	Modernism			Adherence	Absence of level
United States of America	Bloomfield Hills	Modernism			Adherence	Absence of level
Denmark	Klampenborg	Modernism			Adherence	Absence of level

Appendix

ID	Architect Name	Building Name	Status	Type	Building Type	Year	Continent
	Serge Chermayeff	Bentley Wood	Built	Building	Residential	1938	Europe
	Alvar Aalto	Villa Mairea	Built	Building	Residential	1939	Europe
	Harry Seidler	Rose Seidler House	Built	Building	Residential	1950	Oceania
	Jean Prouve	Maison Prouve	Built	Building	Residential	1954	Europe
	Albert Frey	Frey House II	Built	Building	Residential	1964	North America
	Alison & Peter Smitson	Upper Lawn Pavilion	Built	Building	Residential	1962	Europe
	John Lautner	Elrod Residence	Built	Building	Residential	1968	North America
	Richard & Su Rogers	Dr Rogers House	Built	Building	Residential	1969	Europe
	Craig Ellwood	Palevsky House	Built	Building	Residential	1970	North America
	Agustin Hernandez	Casa Hernandez	Built	Building	Residential	1970	North America
	Scott Tallon Walker	Goulding House	Built	Building	Residential	1972	Europe











Appendix

Country	City	Period of history	image	Diagram	Main Relationship	Touches Ground
United Kingdom	East Sussex	Modernism			Adherence	Plinth
Finland	Noormarkku	Modernism			Adherence	Plinth
United Kingdom	Wahroonga	Postmodernism			Separation	Ungrounded
France	Lorraine	Postmodernism			Interlock	Foundation
United States of America	Palm Springs	Postmodernism			Interlock	Foundation
United Kingdom	England	Postmodernism			Adherence	Plinth
United States of America	Palm Springs	Postmodernism			Interlock	Foundation
United Kingdom	London	Postmodernism			Adherence	Absence of level
United States of America	Palm Springs	Postmodernism			Adherence	Absence of level
Mexico	Mexico City	Postmodernism			Separation	Ungrounded
Ireland	County Wicklow	Postmodernism			Separation	Ungrounded

Appendix

ID	Architect Name	Building Name	Status	Type	Building Type	Year	Continent
	Peter Eisenman	House Vi	Built	Building	Residential	1975	North America
	Michael & Patty Hopkins	Hopkins House	Built	Building	Residential	1976	Europe
	Frank Gehry	Gehry House	Built	Building	Residential	1978	North America
	Tadao Ando	Koshino House	Built	Building	Residential	1981	Asia
	Jan Benthem	Benthem House	Built	Building	Residential	1984	Europe
	Glenn Murcutt	Simpson-Lee House	Built	Building	Residential	1994	Oceania
	Shigeru Ban	Paper House	Built	Building	Residential	1995	Asia
	Future Systems	House In Wales	Built	Building	Residential	1996	Europe
	Eduardo Souto De Moura	Moledo House	Built	Building	Residential	1998	Europe
	Sean Godsell	Carter /Tucker House	Built	Building	Residential	2000	Oceania
	Isay Weinfeld	Casa Grecia	Built	Building	Residential	2009	South America











Appendix

Country	City	Period of history	image	Diagram	Main Relationship	Touches Ground
United States of America	Connecticut	Postmodernism			Adherence	Absence of level
United Kingdom	London	Postmodernism			Adherence	Absence of level
United States of America	Los Angeles	Postmodernism			Adherence	Plinth
Japan	Hyogo	Postmodernism			Interlock	Foundation
Netherlands	Amsterdam	Postmodernism			Separation	Ungrounded
New South Wales	Mount Wilson	Postmodernism			Separation	Ungrounded
Japan	Yamanashi	Postmodernism			Separation	Artificial Ground
United Kingdom	Wales	Postmodernism			Interlock	Grounded
Portugal	Caminha	Postmodernism			Interlock	Foundation
Australia	Breamlea	Contemporary			Interlock	Foundation
Brazil	Sao Paulo	Contemporary			Interlock	Foundation

Appendix

ID	Architect Name	Building Name	Status	Type	Building Type	Year	Continent
	Emre Arolat	Sancaklar Mosque	Built	Building	Public	2015	Asia
	Oppenheim	Wadi Rum Desert Resort	Unbuilt	Building	Public	2013	Asia
	Gray Puksand	Peters Ice Cream	Built	Building	Public	2016	Oceania
	Francis-Jones Morehen Thorp (FJMT)	University of Sydney Law School	Built	Building	Public	2009	Oceania
	JDS Architects	Mountain Dwellings	Built	Building	Residential	2008	Europe
	Arons en gelauff architecten	Pontseiger	Built	Building	Public	2011	Europe
	TV AAPROG – BOECKX. – B2Ai	AZ Zeno Knokke- Heist	Built	Building	Public	2017	Europe
	WOHA	Kampung Admiralty	Built	Building	Public	2017	Asia
	Kieran Timberlake	High Horse Ranch	Built	Building	Residential	2018	North America
	Nikken Sekkei	Shanghai Greenland Center	Built	Building	Public	2017	Asia
	Nextoffice	Guyim Vault House	Unbuilt	Building	Residential	2018	Asia

Appendix

Country	City	Period of history	image	Diagram	Main Relationship	Touches Ground
Turkey	Istanbul	Contemporary			Interlock	Foundation
Jordan	Wadi Rum	Contemporary			Interlock	Grounded
Australia	Melbourne	Contemporary			Separation	Ungrounded
Australia	Sydney	Contemporary			Separation	Ungrounded
Denmark	Copenhagen	Contemporary			Separation	Ungrounded
Netherlands	Amsterdam	Contemporary			Separation	Ungrounded
Belgian	Flanders	Contemporary			Separation	Ungrounded
Singapore	Singapore	Contemporary			Separation	Ungrounded
United States of America	California	Contemporary			Adherence	Absence of level
China	Shanghai	Contemporary			Interlock	Grounded
Iran	Shiraz	Contemporary			Separation	Artificial Ground

Appendix: V
Image Sorting Survey Questionnaire



Welsh School of Architecture
Ysgol Pensaerniaeth Cymru

Welcome

Welcome to this OptimalSort study.

The activity shouldn't take longer than **15 minutes** to complete.

Your response will help us to categorise the building and ground relationships

Find out how on the next page...

Continue



Welsh School of Architecture
Ysgol Pensaernïaeth Cymru

Kindly Specify your Architectural Career.

- Undergraduate Architecture Student
- Graduated Architecture Student (Master or PhD.)
- Architectural Academic Staff (lecturer or Reader or Professor)
- Architectural Practitioner
- Non-Architect

← Back

Continue



Welsh School of Architecture
Ysgol Pensaernïaeth Cymru

Participant Information Sheet

Name of Department: Welsh School of Architecture

Title of Study: Using Artificial intelligent/ Machine learning Methods to Uncover building and ground relationships.

Introduction

My name is Abdulrahman Alymani and I am a Ph.D. student at Cardiff University, UK, under the supervision of Dr. Wassim Jabi, who is a Reader in Architectural Computational Methods. We are conducting research on using Artificial Intelligent Machine Learning Methods to Uncover building and ground relationships.

What is the purpose of this investigation?

Building and ground relationships have been dispersed around the architectural discipline. Therefore, the aim of the current research is to understand and cluster this relationship through sorting a case study on a computational database.

Do you have to take part?

Participation in the image sorting workshop is completely voluntary. It is totally your decision to decide whether you want to take part in the interview or NOT.

What will you do in the project?

We are conducting an image sorting workshop for four-levels affiliated on the field of architecture (i.e. undergraduate student, postgraduate student, an academic staff member, and an architect practitioner). We are interested to know what your major is and where this sorting takes place. After a short presentation, we would also like to present you with 30 architectural precedents and ask you to sort it in relation to a category that will be given to you. The image sorting workshop will be video recording and will

Continue

be completely confidential and anonymous. During the workshop, you will be able to stop at any moment you wish; you can also ask for a break or finish another time. Moreover, you can reject to answer any questions; the workshop will be video recorded, although only if you agree.

What happens to the information in the project?

Any information provided will be completely private and anonymous. Nobody will be identified in the final report and your name, if you provide it, will not be used anywhere.

How will my personal information be used?

All data will be securely stored during the research project. No person will be identified in the research project and results will remain anonymous. Any identifiable information (e.g. names, locations) will be removed from the final transcript used for analysis.

Thank you for reading this information – please ask any questions if you are unsure about what is written here.

What happens next?

If you are happy to be involved in the project, please sign the consent form. If you do not wish to be involved, thank you for your time.

Note: This investigation was granted with ethical approval by the School Research Ethics Committee, Welsh School of Architecture.

Researcher Contact Details:
Abdulrahman Alymani PhD.
Welsh School of Architecture
Cardiff University
Bute Building (Level 3)
King Edward VII Ave.
CARDIFF CF10 3NB
Tel: 07305595852
Email: Alymanias@cardiff.ac.uk

Continue



Consent Form

1. I confirm that I have read the information above and have had an opportunity to ask questions regarding the activity and how my information will be used.
2. I understand that participation in this study is entirely voluntary and that I can withdraw from the study at any time without providing a reason.
3. I understand that my participation in this project will involve completing image sorting, which relates to "building and ground relationship". This sorting workshop survey will require approximately 20 minutes of my time.
4. I understand that personal information collected about me, which will be able to identify me, such as my name or where I live, will not be shared beyond the study team.
5. I understand that I can ask for the information I provide to be deleted/destroyed at any time and, in accordance with the Data Protection Act, I can have access to the information at any time.
6. I agree to be video recorded during the image sorting workshop. (Video recording will be limited to the screen)
7. I agree to take part in the above study.

I agree

I disagree

← Back

Continue



Welsh School of Architecture
Ysgol Pensaernïaeth Cymru

Consent Form Agreement

Title of Project: Sorting Images into clusters of building and ground relationship taxonomy

Name of Researcher: Abdulrahman Alymani

Participant Name (optional)

← Back

Continue



Welsh School of Architecture
Ysgol Pensaernïaeth Cymru

Building and ground relationships have been dispersed around the architectural discipline. Therefore, the aim of this research is to understand and cluster this relationship, through sorting a case study on a computational database.

In general, all building and ground relationships fit into 3 Main categories: 1-Interlock 2-Separation 3-Adherence.

Do not worry if the building/ground relationship is not clear. Make the best estimate of what you think that relationship is. There are no clear-cut answers in most cases.

A text input field with a dropdown arrow on the right side, containing the text 'I understand'.

← Back

Continue

Interlock

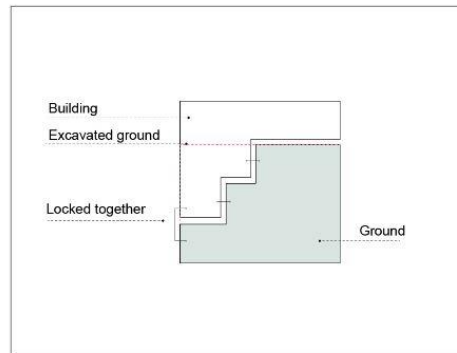

1. Interlock: defined as “to become locked together or interconnected”. Interlock means a configuration of the ground with the construction while sharing a space completely that complements each other (Berlanda, 2014).

I understand



← Back

Continue



Separation

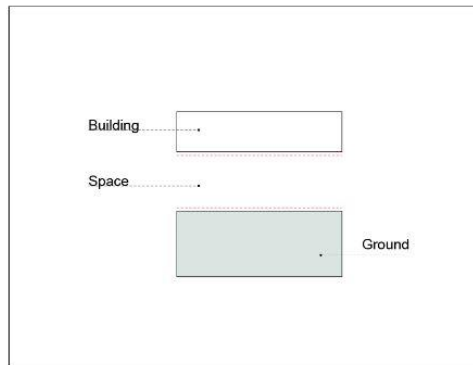

2. Separation: defines as lifting the building from the ground (on punctual supports) or limiting the links with the ground into a series of point (Berlanda, 2014).

← Back

Continue

Adherence

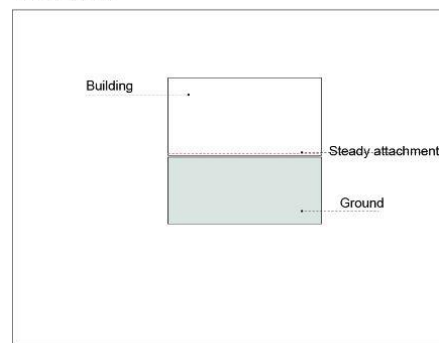

3.Adherence: defined in relation to buildings that stick to the ground or are laid like a carpet on the terrain. Moreover, this relates to the use of light consolidations or thin platform to serve as an artificial groundwork that traces the building's contour lines (Berlanda, 2014).

I understand



← Back

Continue

Appendix

View in picture | Leave a comment | **Pin**

Interlock	Separation	Adherence
0 items	0 items	0 items

157
177
840
170
217

Activate Windows
Go to Settings to activate Windows.

Use in picture | Leave a comment | **Pin**

View in picture | Leave a comment | **Pin**

Interlock	Separation	Adherence
0 items	2 items	0 items

152
212
260
261
99

157
82
190

Activate Windows
Go to Settings to activate Windows.

Use in picture | Leave a comment | **Pin**

Appendix: VI
Image Sorting Survey Ethical
Approval Forms

WELSH SCHOOL OF ARCHITECTURE ETHICS APPROVAL FORM FOR STAFF AND PHD/MPHIL PROJECTS		WS		
Tick one box:	<input type="checkbox"/> STAFF	<input checked="" type="checkbox"/> PHD/MPHIL		
Title of project:	Sorting Architecture precedents Images into clusters of building and ground relationship taxonomy			
Name of researcher(s):	Abdulrahman Ahmed Alymani			
Name of principal investigator:	Abdulrahman Ahmed Alymani, under Dr Wassim Jabi supervision.			
Contact e-mail address:	Alymaniaa@cardiff.ac.uk			
Date:	12/11/19			
Participants		YES	NO	N/A
Does the research involve participants from any of the following groups?	• Children (under 16 years of age)		√	
	• People with learning difficulties		√	
	• Patients (NHS approval is required)		√	
	• People in custody		√	
	• People engaged in illegal activities		√	
	• Vulnerable elderly people		√	
	• Any other vulnerable group not listed here		√	
• When working with children: I have read the Interim Guidance for Researchers Working with Children and Young People (http://www.cardiff.ac.uk/archi/ethics_committee.php)				√
Consent Procedure		YES	NO	N/A
• Will you describe the research process to participants in advance, so that they are informed about what to expect?		√		
• Will you tell participants that their participation is voluntary?		√		
• Will you tell participants that they may withdraw from the research at any time and for any reason?		√		
• Will you obtain valid consent from participants? (specify how consent will be obtained in Box A) ¹		√		
• Will you give participants the option of omitting questions they do not want to answer?		√		
• If the research is observational, will you ask participants for their consent to being observed?		√		
• If the research involves photography or other audio-visual recording, will you ask participants for their consent to being photographed / recorded and for its use/publication?		√		
Possible Harm to Participants		YES	NO	N/A
• Is there any realistic risk of any participants experiencing either physical or psychological distress or discomfort?			√	
• Is there any realistic risk of any participants experience a detriment to their interests as a result of participation?			√	
Data Protection		YES	NO	N/A
• Will any non-anonymous and/or personalised data be generated or stored?			√	
• If the research involves non-anonymous and/or personalised data, will you:	• gain written consent from the participants	√		
	• allow the participants the option of anonymity for all or part of the information they provide	√		
Health and Safety		YES		
Does the research meet the requirements of the University's Health & Safety policies? (http://www.cf.ac.uk/osheu/index.html)		√		
Research Governance		YES	NO	N/A
Does your study include the use of a drug? You need to contact Research Governance before submission (resgov@cf.ac.uk)			√	
Does the study involve the collection or use of human tissue? You need to contact the Human Tissue Act team before submission (hta@cf.ac.uk)			√	

¹ If any non-anonymous and/or personalised data be generated or stored, *written consent* is required.

Prevent Duty	YES
Has due regard be given to the 'Prevent duty', in particular to prevent anyone being drawn into terrorism? https://www.gov.uk/government/uploads/system/uploads/attachment_data/file/445916/Prevent_Duty_Guidance_For_Higher_Education_England_Wales_.pdf http://www.cardiff.ac.uk/publicinformation/policies-and-procedures/freedom-of-speech	√

If any of the shaded boxes have been ticked, you must explain in Box A how the ethical issues are addressed. If none of the boxes have been ticked, you must still provide the following information. The list of ethical issues on this form is not exhaustive; if you are aware of any other ethical issues you need to make the SREC aware of them.

Box A The Project (provide all the information listed below in a separate attachment)

1. Title of Project
Sorting Architecture precedents images into clusters of building and ground relationship taxonomy

2. Purpose of the project and its academic rationale
Building and ground relationships have been dispersed around the architectural discipline. Therefore, the aim of the current research is to understand and cluster this relationship through sorting a case study on a computational database.

3. Brief description of methods and measurements
We are conducting an image sorting workshop for four-levels affiliated on the field of architecture (i.e. undergraduate student, postgraduate student, an academic staff member, and an architect practitioner). We are interested to know what your major is and where this sorting takes place. After a short presentation, we would also like to present you with 30 architectural precedents and ask you to sort it in relation to a category that will be given to you. The image sorting workshop will be video recording and will take between 15 minutes of your time in total. The workshop will be completely confidential and anonymous. During the workshop, you will be able to stop at any moment you wish; you can also ask for a break or finish another time. Moreover, you can reject to answer any questions; the workshop will be video recorded, although only if you agree.

4. Participants: recruitment methods, number, age, gender, exclusion/inclusion criteria
Four-levels affiliated on the field of architecture (i.e. undergraduate student, postgraduate student, an academic staff member, and an architect practitioner) other than this participant will exclusion of the workshop. Need at least 40 persons in each category. The total of participants will approximately be 160 participants.

5. Consent and participation information arrangements - please attached consent forms if they are to be used

- I confirm that I have read the information above and have had an opportunity to ask questions regarding the activity and how my information will be used.
- I understand that participation in this study is entirely voluntary and that I can withdraw from the study at any time without providing a reason.
- I understand that my participation in this project will involve completing image sorting, which relates to "building and ground relationship". This sorting workshop survey will require approximately 20 minutes of my time.
- I understand that personal information collected about me, which will be able to identify me, such as my name or where I live, will not be shared beyond the study team.
- I understand that I can ask for the information I provide to be deleted/destroyed at any time and, in accordance with the Data Protection Act, I can have access to the information at any time.
- I agree to be video recorded during the image sorting workshop.
- I agree to take part in the above study.
 - I agree
 - I disagree

Appendix

6. A clear and concise statement of the ethical considerations raised by the project and how is dealt with them

I consider this sorting workshop to have negligible ethical implications.

7. Estimated start date and duration of project

The card sorting workshop will be started on 20 of November and will take 3 months from that time.

All information must be submitted along with this form to the School Research Ethics Committee for consideration

Researcher's declaration (tick as appropriate)

- | | |
|---|---|
| <input checked="" type="checkbox"/> I consider this project to have negligible ethical implications (<i>can only be used if none of the grey areas of the checklist have been ticked</i>). | ✓ |
| <input type="checkbox"/> I consider this project research to have some ethical implications . | |
| <input type="checkbox"/> I consider this project to have significant ethical implications | |

Signature *abdurahmanalymani* CONFIDENTIAL Name Abdulrahman Alymani Date 14/11/2019
Researcher

Signature *abdurahmanalymani* CONFIDENTIAL Name Dr Wassim Jabi Date 14/11/2019
Lead investigator

Advice from the School Research Ethics Committee

STATEMENT OF ETHICAL APPROVAL

This project had been considered using agreed Departmental procedures and is now approved

Signature *abdurahmanalymani* CONFIDENTIAL Name Dr Chris Whitman Date 20/11/19
Chair, School Research Ethics Committee

Appendix: VII
Responses from the Participants
Main Building and Ground Relationship Sorting
Survey (One)

Appendix

Popular placements matrix 

	Interlock	Separation	Adherence	unsorted
104	100%			
107	100%			
112	100%			
140	100%			
141	100%			
155	100%			
163	100%			
171	100%			
172	100%			
175	100%			
181	100%			
182	100%			
200	100%			
201	100%			
209	100%			
212	100%			
216	100%			
218	100%			
222	100%			
223	100%			
243	100%			
249	100%			
32	100%			
4	100%			
42	100%			
46	100%			
67	100%			
69	100%			
70	100%			
76	100%			
135	86%	14%		
184	83%		17%	
185	83%		17%	
190	83%		17%	
217	83%		17%	
256	83%	17%		
116	80%		20%	
122	80%		20%	
130	80%		20%	
134	80%		20%	
150	80%		20%	
154	80%	20%		
160	80%		20%	
173	80%		20%	
73	80%		20%	
110	75%		25%	
127	75%		25%	
143	75%		25%	
149	75%	25%		
169	75%		25%	
174	75%		25%	
183	75%		25%	
214	75%	13%	13%	
81	75%		25%	
219	71%		29%	
103	67%	33%		
129	67%		33%	
153	67%		33%	
187	67%		33%	
204	67%		33%	
22	67%	33%		
24	67%		33%	
245	67%		33%	
52	67%		33%	
53	67%		33%	
61	67%	33%		
71	67%		33%	
72	67%	17%	17%	
74	67%	17%	17%	
92	67%	33%		
118	60%	40%		
142	60%		40%	
221	60%	20%	20%	
5	60%		40%	
27	57%	14%	29%	
113	56%	33%	11%	
40	56%		44%	

Appendix

102	50%	17%	33%		17	100%		
108	50%	50%			170	100%		
109	50%		50%		177	100%		
126	50%	17%	33%		188	100%		
137	50%		50%		19	100%		
146	50%	25%	25%		192	100%		
158	50%		50%		198	100%		
162	50%	50%			20	100%		
168	50%		50%		203	100%		
178	50%		50%		225	100%		
199	50%		50%		231	100%		
202	50%		50%		248	100%		
210	50%		50%		264	100%		
211	50%		50%		3	100%		
215	50%		50%		34	100%		
236	50%	25%	25%		57	100%		
255	50%		50%		62	100%		
267	50%	50%			65	100%		
33	50%		50%		68	100%		
37	50%	50%			7	100%		
44	50%		50%		84	100%		
49	50%		50%		88	100%		
56	50%	50%			99	100%		
75	50%	13%	38%		15	88%	13%	
78	50%		50%		152	86%	14%	
161	43%	29%	29%		159	86%	14%	
242	40%	20%	40%		235	14%	86%	
261	40%	20%	40%		250	14%	86%	
41	38%	38%	25%		83		86%	14%
121	33%	33%	33%		9		86%	14%
239	33%	33%	33%		21	17%	83%	
50	33%	33%	33%		253		83%	17%
86	33%	33%	33%		259		83%	17%
10		100%			58		83%	17%
105		100%			59		83%	17%
125		100%			91	17%	83%	
133		100%			95	17%	83%	
145		100%			11	20%	80%	
147		100%			157		80%	20%

Appendix

180		80%	20%		101			100%	
197		80%	20%		114			100%	
205		80%	20%		124			100%	
232	10%	80%	10%		14			100%	
234	20%	80%			144			100%	
131		75%	25%		189			100%	
138		75%	25%		194			100%	
165		75%	25%		2			100%	
186		75%	25%		226			100%	
251		75%	25%		23			100%	
268		75%	25%		241			100%	
60	25%	75%			257			100%	
82		75%	25%		260			100%	
1		71%	29%		263			100%	
106		71%	29%		270			100%	
117		71%	29%		35			100%	
207	14%	71%	14%		39			100%	
8	14%	71%	14%		48			100%	
148		67%	33%		77			100%	
151		67%	33%		80			100%	
195		67%	33%		85			100%	
230		67%	33%		213	10%		90%	
244	17%	67%	17%		237		11%	89%	
254	33%	67%			96	13%		88%	
262	17%	67%	17%		193	14%		86%	
115		60%	40%		233		14%	86%	
139	40%	60%			246	14%		86%	
191		60%	40%		266		14%	86%	
55	20%	60%	20%		31	14%		86%	
128		50%	50%		29	17%		83%	
136		50%	50%		38	17%		83%	
179	38%	50%	13%		94		17%	83%	
206	33%	50%	17%		97	17%		83%	
208		50%	50%		123	20%		80%	
66		50%	50%		18		20%	80%	
79		50%	50%		89	20%		80%	
98		50%	50%		229	25%		75%	
224	14%	43%	43%		25		25%	75%	
63	20%	40%	40%		258	25%		75%	
100			100%						

Appendix

36	25%		75%	
51	25%		75%	
64	25%		75%	
269		29%	71%	
240	30%		70%	
119	33%		67%	
12	33%		67%	
120	11%	22%	67%	
164	33%		67%	
166	17%	17%	67%	
228	33%		67%	
238	33%		67%	
252	33%		67%	
26	33%		67%	
28	33%		67%	
45	17%	17%	67%	
47	33%		67%	
93	33%		67%	
87	9%	27%	64%	
111	40%		60%	
167	40%		60%	
176	40%		60%	
220	40%		60%	
227		40%	60%	
247	20%	20%	60%	
54	20%	20%	60%	
13	29%	14%	57%	
265	43%		57%	
30	29%	14%	57%	
43	14%	29%	57%	
6	43%		57%	
156	25%	25%	50%	
16	25%	25%	50%	
196	25%	25%	50%	
90	29%	29%	43%	
132				

Appendix

The results matrix ?

	Interlock	Separation	Adherence	unsorted
1		5	2	
2			2	
3		3		
4	5			
5	3		2	
6	3		4	
7		3		
8	1	5	1	
9		6	1	
10		1		
11	1	4		
12	1		2	
13	2	1	4	
14			4	
15		7	1	
16	1	1	2	
17		2		
18		1	4	
19		7		
20		3		
21	1	5		
22	2	1		
23			4	
24	2		1	
25		1	3	
26	2		4	
27	4	1	2	
28	1		2	
29	1		5	
30	2	1	4	
31	1		6	
32	3			
33	1		1	
34		2		
35			3	
36	1		3	
37	1	1		

38	1		5	
39			2	
40	5		4	
41	3	3	2	
42	2			
43	1	2	4	
44	3		3	
45	2	2	8	
46	8			
47	2		4	
48			3	
49	1		1	
50	1	1	1	
51	1		3	
52	4		2	
53	2		1	
54	1	1	3	
55	1	3	1	
56	2	2		
57		3		
58		5	1	
59		5	1	
60	1	3		
61	2	1		
62		2		
63	1	2	2	
64	1		3	
65		4		
66		1	1	
67	4			
68		1		
69	4			
70	4			
71	2		1	
72	4	1	1	
73	4		1	
74	4	1	1	
75	4	1	3	
76	4			
77			5	
78	3		3	
79		1	1	
80			5	

Appendix

81	3		1
82		3	1
83		6	1
84		2	
85			4
86	3	3	3
87	1	3	7
88		6	
89	1		4
90	2	2	3
91	1	5	
92	4	2	
93	1		2
94		1	5
95	1	5	
96	1		7
97	1		5
98		2	2
99		1	
100			2
101			7
102	3	1	2
103	2	1	
104	5		
105		2	
106		5	2
107	6		
108	1	1	
109	1		1
110	3		1
111	2		3
112	2		
113	5	3	1
114			5
115		3	2
116	4		1
117		5	2
118	3	2	
119	1		2
120	1	2	6
121	1	1	1
122	4		1
123	1		4
124			1

125		5	
126	3	1	2
127	3		1
128		2	2
129	2		1
130	4		1
131		3	1
132			
133		4	
134	4		1
135	6	1	
136		1	1
137	2		2
138		6	2
139	2	3	
140	3		
141	4		
142	3		2
143	3		1
144			1
145		4	
146	2	1	1
147		4	
148		4	2
149	3	1	
150	4		1
151		2	1
152		6	1
153	2		1
154	4	1	
155	1		
156	1	1	2
157		4	1
158	2		2
159		6	1
160	4		1
161	3	2	2
162	1	1	
163	1		
164	2		4
165		3	1
166	1	1	4
167	2		3
168	1		1

Appendix

169	3		1
170		1	
171	5		
172	2		
173	4		1
174	3		1
175	2		
176	2		3
177		6	
178	2		2
179	3	4	1
180		4	1
181	4		
182	3		
183	3		1
184	5		1
185	5		1
186		3	1
187	2		1
188		2	
189			1
190	5		1
191		3	2
192		4	
193	1		6
194			2
195		2	1
196	1	1	2
197		4	1
198		3	
199	1		1
200	5		
201	2		
202	2		2
203		1	
204	2		1
205		4	1
206	2	3	1
207	1	5	1
208		2	2
209	6		
210	1		1
211	1		1
212	1		

212	1		
213	1		9
214	6	1	1
215	2		2
216	2		
217	5		1
218	2		
219	5		2
220	2		3
221	3	1	1
222	3		
223	3		
224	1	3	3
225		3	
226			2
227		2	3
228	2		4
229	1		3
230		2	1
231		4	
232	1	8	1
233		1	6
234	1	4	
235	1	6	
236	4	2	2
237		1	8
238	1		2
239	2	2	2
240	3		7
241			6
242	2	1	2
243	3		
244	1	4	1
245	2		1
246	1		6
247	1	1	3
248		4	
249	4		
250	1	6	
251		3	1
252	2		4

Appendix

241			6	
242	2	1	2	
243	3			
244	1	4	1	
245	2		1	
246	1		6	
247	1	1	3	
248		4		
249	4			
250	1	6		
251		3	1	
252	2		4	
253		5	1	
254	1	2		
255	3		3	
256	5	1		
257			6	
258	1		3	
259		5	1	
260			4	
261	2	1	2	
262	1	4	1	
263			3	
264		7		
265	3		4	
266		1	6	
267	2	2		
268		6	2	
269		2	5	
270			1	

© 2022 Optimal Workshop Ltd. All rights reserved.

Use of Optimal Workshop signifies agreement with our [Privacy Notice](#) and [Terms of Service](#).

Appendix: VIII
Responses from the Participants
Building Meet the Ground Image Sorting Survey (Two)

Appendix

Popular placements matrix 

	Grounded	Ungrounded	Foundation	Plinth	Artificial Ground	Absence of level	unsorted
127	100%						
155	100%						
168	100%						
185	100%						
215	100%						
249	100%						
76	100%						
169	86%	14%					
202	86%		14%				
217	83%		17%				
154	80%		20%				
221	80%	20%					
107	75%				13%	13%	
109	75%					25%	
265	75%					25%	
172	71%				14%	14%	
190	71%				14%	14%	
183	67%			33%			
201	67%		33%				
219	67%				33%		
228	67%	33%					
160	60%		20%			20%	
161	60%	20%			20%		
210	60%		20%			20%	
42	60%		40%				
182	57%				29%	14%	
174	56%		22%		22%		
220	56%				22%	22%	
108	50%				50%		
111	50%	17%			33%		
122	50%			25%	25%		
129	50%		17%		33%		
13	50%					50%	
130	50%		17%			33%	
134	50%		50%				

Appendix

150	50%				50%		
180	50%	25%			25%		
181	50%	17%			33%		
184	50%	50%					
199	50%	50%					
200	50%		50%				
212	50%		50%				
216	50%		50%				
218	50%	17%	17%		17%		
223	50%	50%					
229	50%		50%				
236	50%		25%		25%		
243	50%		50%				
256	50%		50%				
40	50%			50%			
41	50%					50%	
69	50%					50%	
175	44%			22%	33%		
142	43%	14%	29%			14%	
46	43%		29%			29%	
120	40%				40%	20%	
73	40%				40%	20%	
90	40%	20%	40%				
110	33%				33%	33%	
144	33%		33%		33%		
146	33%	33%		33%			
164	33%			33%	33%		
171	33%			33%	17%	17%	
222	33%				33%	33%	
238	33%		33%			33%	
245	33%	33%			33%		
263	33%			33%		33%	
27	33%				33%	33%	
33	33%	17%	17%	17%		17%	
39	33%		33%	33%			
49	33%		33%			33%	

Appendix

49	33%		33%			33%	
52	33%	33%	33%				
67	33%	33%			33%		
80	33%		33%			33%	
1	29%	29%	14%	14%		14%	
137	29%			14%	29%	29%	
74	29%		14%	29%	29%		
14	25%		25%	25%		25%	
163	25%		25%		25%	25%	
176	25%	25%	25%		25%		
89	25%		25%	25%		25%	
138		100%					
148		100%					
159		100%					
170		100%					
177		100%					
178		100%					
192		100%					
206		100%					
56		100%					
61		100%					
68		100%					
95		100%					
99		100%					
251		83%		17%			
125		80%			20%		
162		80%	20%				
262		80%	20%				
264		80%			20%		
145		75%	25%				
15	25%	75%					
231		75%		25%			
232		75%				25%	
59		75%		25%			
8		75%	25%				
115		67%	33%				

Appendix

131		67%			33%	
152		67%			33%	
16		67%		33%		
19		67%		33%		
195		67%				33%
203		67%				33%
209		67%		33%		
248		67%		33%		
258		67%				33%
57	33%	67%				
63		67%		33%		
82		67%	33%			
9		67%	33%			
165		60%	40%			
197		60%		20%	20%	
7		60%	20%	20%		
86		57%			43%	
113		50%		50%		
126		50%			50%	
173		50%		50%		
186		50%	33%			17%
204	17%	50%	17%		17%	
205	17%	50%	17%	17%		
224		50%		25%	25%	
230		50%	25%	25%		
235		50%	25%	25%		
244		50%		50%		
254		50%	25%	25%		
268		50%	50%			
3		50%				50%
51		50%				50%
54		50%				50%
55		50%		25%		25%
58	25%	50%	25%			
60		50%	50%			

Appendix

83		50%		25%	25%		
92	25%	50%	25%				
147		40%	10%	30%	10%	10%	
157		40%	40%			20%	
84	20%	40%	40%				
91	20%	40%	40%				
12		33%	33%			33%	
166		33%	17%	17%	33%		
188	17%	33%	17%		17%	17%	
196		33%	33%			33%	
20	17%	33%	33%			17%	
21		33%	33%	33%			
253		33%		33%	33%		
267		33%	17%	17%	33%		
214			100%				
226			100%				
234			100%				
114	25%		75%				
118		33%	67%				
44			67%	33%			
139	20%	20%	60%				
143	20%		60%	20%			
72	20%		60%		20%		
100		25%	50%	25%			
11		25%	50%			25%	
121			50%		50%		
133	25%	25%	50%				
135	17%		50%			33%	
136		25%	50%	25%			
198			50%		50%		
239			50%			50%	
270			50%	50%			
36			50%	50%			
37	17%		50%	17%	17%		
43	25%	25%	50%				
62	25%	25%	50%				

Appendix

97			50%	50%		
104	29%		43%		14%	14%
47		14%	43%		29%	14%
17	20%	20%	40%	20%		
213	20%		40%	20%		20%
233		20%	40%			40%
32	20%		40%		40%	
70			40%	20%	40%	
71			33%	33%		33%
141		14%	29%	29%		29%
25			25%	25%	25%	25%
255			25%	25%	25%	25%
24				100%		
34				100%		
81				100%		
26	20%			80%		
5				75%		25%
191				67%		33%
98		33%		67%		
103			20%	60%		20%
247				56%	11%	33%
156				50%		50%
189				50%		50%
23	25%	25%		50%		
250				50%		50%
28			25%	50%	25%	
48				50%	50%	
93	25%			50%		25%
2		20%	20%	40%	20%	
45		20%		40%		40%
94			20%	40%		40%
259				33%	33%	33%
87				33%	33%	33%
124					100%	
22					100%	
269					100%	
65					100%	
66					100%	
116			25%		75%	
75				25%	75%	
78					75%	25%
117				33%	67%	
119		11%	11%	11%	67%	
18					67%	33%
106			20%		60%	20%
207	20%			20%	60%	
112	25%		25%		50%	
149			25%	25%	50%	

Appendix

153					50%	50%
179			25%	25%	50%	
85					50%	50%
88		25%			50%	25%
151	17%	17%	17%		33%	17%
102						100%
123						100%
132						100%
158						100%
242						100%
261						100%
266						100%
31						100%
79						100%
10				17%		83%
240	25%					75%
6			14%	14%		71%
101	33%					67%
193				33%		67%
227			17%	17%		67%
246	11%		11%		11%	67%
260	17%				17%	67%
53			33%			67%
64				33%		67%
38	20%			20%		60%
77	20%			20%		60%
194		14%		14%	14%	57%
128	25%			25%		50%
187	25%				25%	50%
211	25%			25%		50%
237	25%	25%				50%
105		29%	14%		14%	43%
96	14%		29%	14%		43%
208		20%	20%		20%	40%
241			20%	20%	20%	40%
252	20%		20%		20%	40%
257	20%	20%			20%	40%
35	20%	20%	20%			40%
140						
167						
225						
29						
30						
4						
50						

Appendix

The results matrix

	Grounded	Ungrounded	Foundation	Plinth	Artificial Ground	Absence of level
1	2	2	1	1		1
2		1	1	2	1	
3		1				1
4						
5				3		1
6			1	1		5
7		3	1	1		
8		3	1			
9		2	1			
10				1		5
11		1	2			1
12		1	1			1
13	2					2
14	1		1	1		1
15	1	3				
16		2		1		
17	1	1	2	1		
18					2	1
19		4		2		
20	1	2	2			1
21		1	1	1		
22					1	
23	1	1		2		
24				2		
25			1	1	1	1
26	1			4		
27	1				1	1
28			1	2	1	
29						
30						2
31						
32	1		2		2	
33	2	1	1	1		1
34				1		
35	1	1	1			2
36			2	2		
37	1		3	1	1	
38	1			1		3
39	1		1	1		
40	1			1		
41	1					1
42	3		2			
43	1	1	2			
44			2	1		
45		1		2		2
46	3		2			2
47		1	3		2	1
48				3	3	
49	1		1			1
50						
51		1				1
52	2	2	2			
53			1			2
54					1	
55					2	
56					2	
57	1				2	
58	1				2	1
59					3	1
60					1	1
61					2	
62	1				1	2
63					2	
64						1
65						1
66						1
67	1				1	1
68					2	
69	2					
70					2	1
71					1	1
72	1				3	
73	2					1
74	2				1	2
75						1
76	2					3
77	1					1
78						3
79						2
80	1					1
81						1
82						2
83						2
84	1					2
85						1
86						4
87						1
88						1
89	1					1
90	2					1
91	1					2
92	1					2
93	1					2
94						1
95						3
96	1					2
97						2
98						1
99						2
100						1
101	1					2
102						2
103						1
104	2					3
105						2
106						1
107	6					3
108	2					1
109	3					2
110	1					1
111	3					1
112	1					2

Appendix

113		1		1		
114		1	3			
115		2	1			
116			1		3	
117				1	2	
118		1	2			
119		1	1	1	6	
120	2				2	1
121			1		1	
122	2			1	1	
123						1
124					2	
125		4			1	
126		1			1	
127	2					
128	1			1		2
129	3		1		2	
130	3		1			2
131		2			1	
132						1
133	1	1	2			
134	1		1			
135	1		3			2
136		1	2	1		
137	2			1	2	2
138		3				
139	1	1	3			
140						
141		1	2	2		2
142	3	1	2			1
143	1		3	1		
144	1		1		1	
145		3	1			
146	1	1		1		
147		4	1	3	1	1
148		3				
149			1	1	2	
150	1				1	
151	1	1	1		2	1
152		2			1	
153					1	1
154	4		1			
155	1					
156				1		1
157		2	2			1
158						1
159		3				
160	3		1			1
161	3	1			1	
162		4	1			
163	1		1		1	1
164	1			1	1	
165		3	2			
166		2	1	1	2	
167						
168	2					
169	6	1				
170		2				

171	2			2	1	1
172	5				1	1
173		1		1		
174	5		2		2	
175	4			2	3	
176	1	1	1		1	
177		1				
178		1				
179			1	1	2	
180	2	1			1	
181	3	1			2	
182	4				2	1
183	2			1		
184	1	1				
185	3					
186		3	2			1
187	1				1	2
188	1	2	1		1	1
189				1		1
190	5				1	1
191				2		1
192		2				
193				1		2
194		1		1	1	4
195		2				1
196		1	1			1
197		3		1	1	
198			1		1	
199	1	1				
200	2			2		
201	2			1		
202	6			1		
203		2				1
204	1	3	1		1	
205	1	3	1	1		
206		2				
207	1			1	3	
208		1	1		1	2
209		2		1		
210	3			1		1
211	1				1	2
212	2			2		
213	1			2	1	1
214				3		
215	4					
216	2			2		
217	5			1		
218	3	1	1		1	
219	2				1	
220	5				2	2
221	4	1				
222	1				1	1
223	1	1				
224		2		1	1	
225						
226				1		
227				1	1	4
228	2	1				
229	1			1		

Appendix

230		2	1	1		
231		3		1		
232		3				1
233		1	2			2
234			1			
235		2	1	1		
236	2		1		1	
237	1	1				2
238	1		1			1
239			1			1
240	1					3
241			1	1	1	2
242						1
243	2		2			
244		1		1		
245	1	1			1	
246	1		1		1	6
247				5	1	3
248		2		1		
249	1					
250				1		1
251		5		1		
252	1		1		1	2
253		1		1	1	
254		2	1	1		
255			1	1	1	1
256	1		1			
257	1	1			1	2
258		2				1
259				1	1	1
260	1				1	4
261						1
262		4	1			
263	1			1		1
264		4			1	
265	3					1
266						3
267		2	1	1	2	
268		1	1			
269					3	
270			1	1		

Appendix: IX
Screenshots for Components of the
Computational Model for carrying out Generated
Syntactical 3D Topological (BGR), using
Rhino/Grasshopper

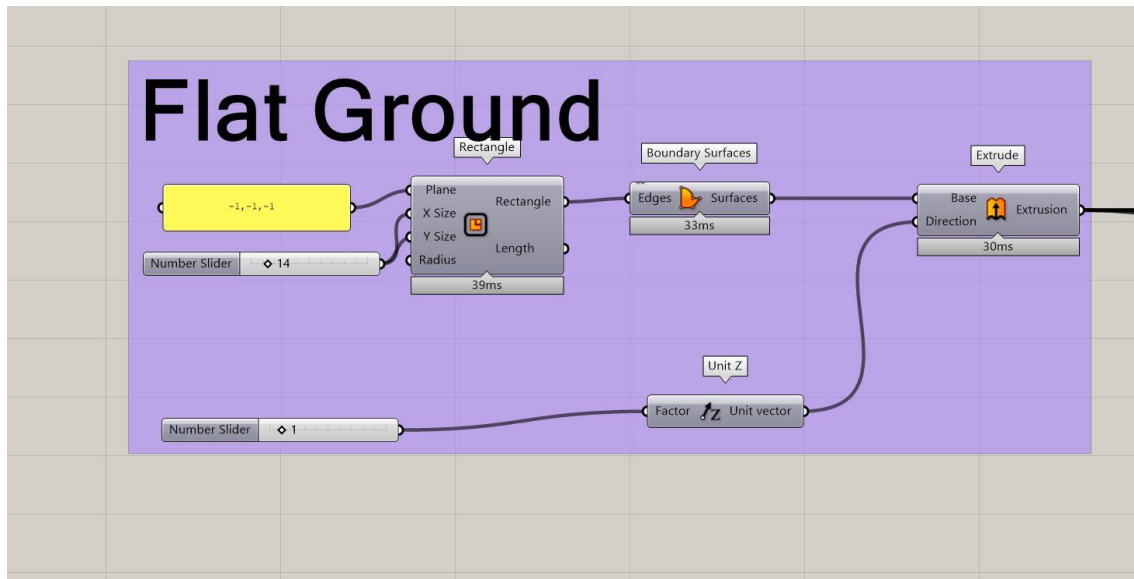

A screenshot showing the created flat ground geometries

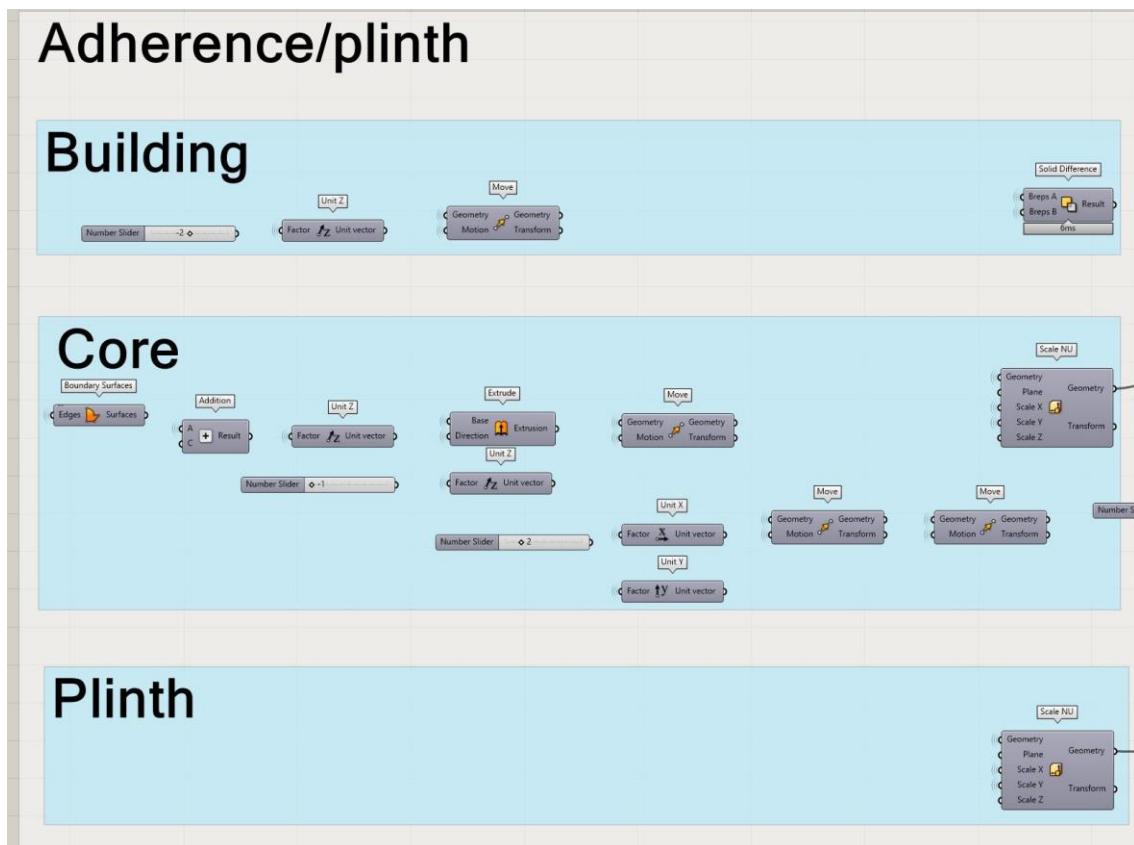

A screenshot showing the created building, core, and Plinth geometries for adherence with plinth approaches

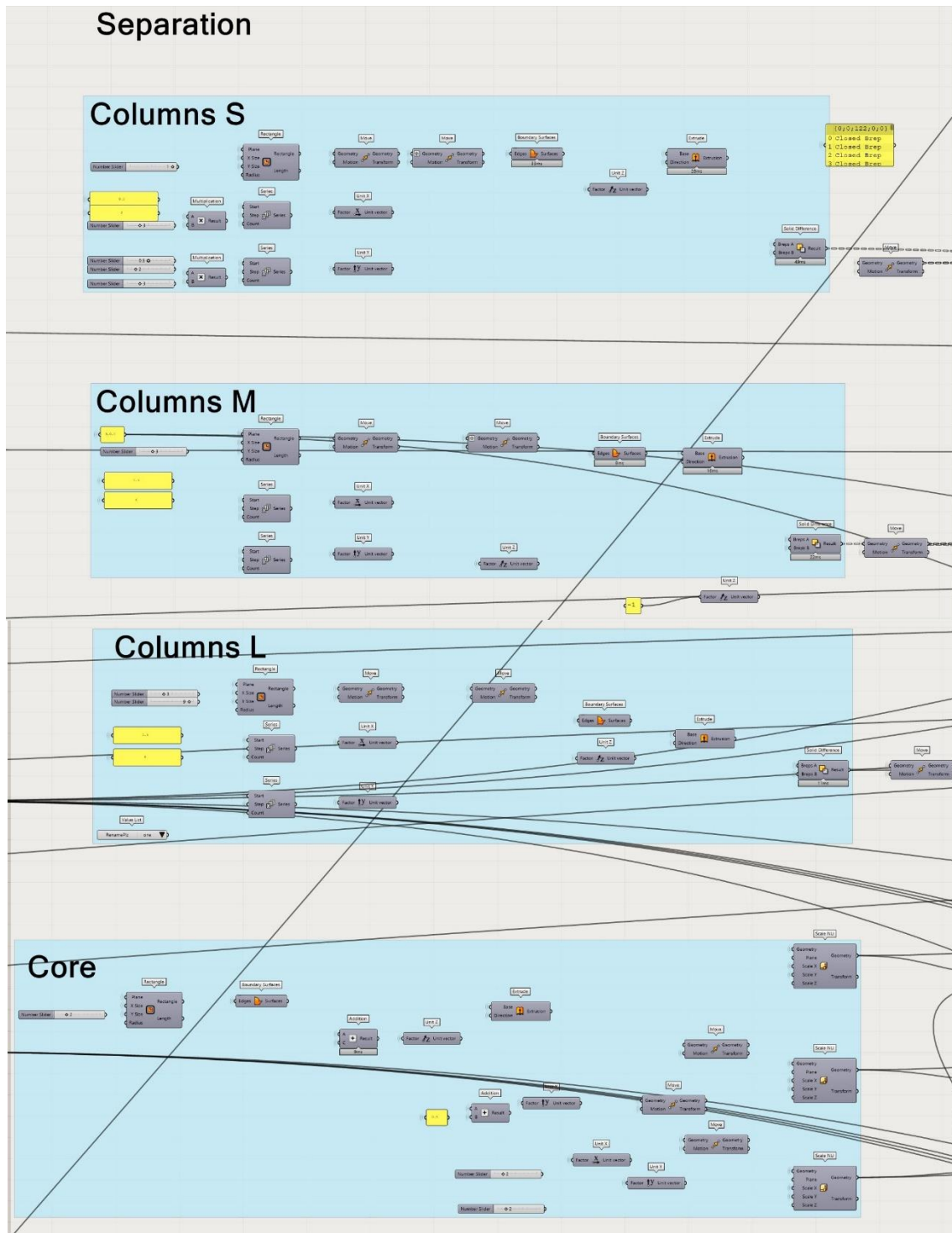

A screenshot showing the created the different size columns and core geometries for separation approaches

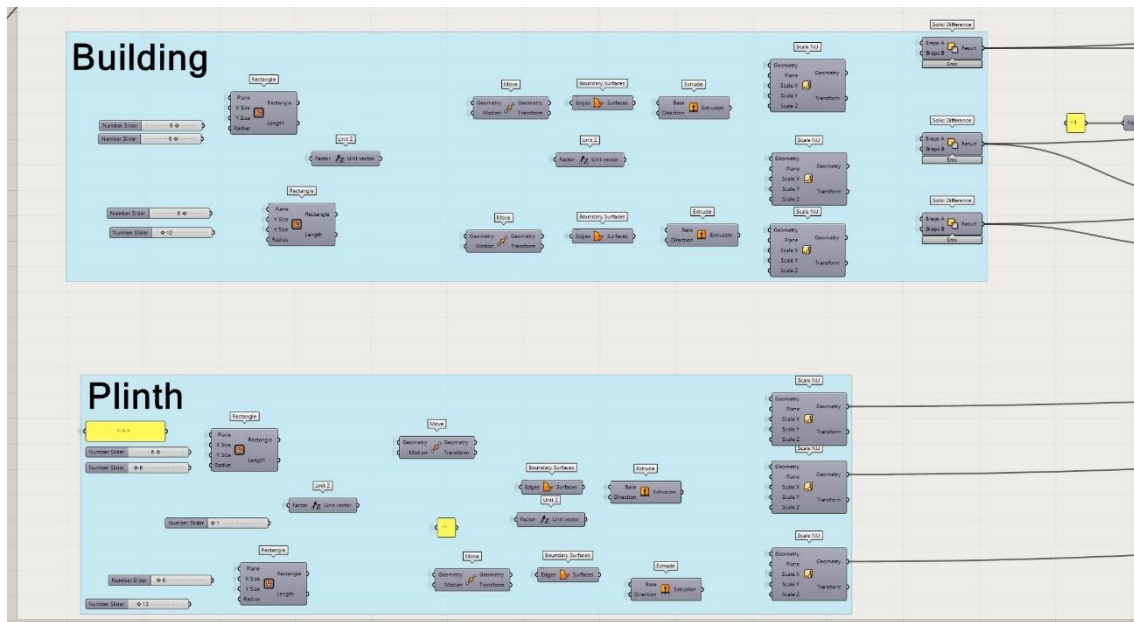

A screenshot showing the building and plinth geometries for separation with plinth approaches

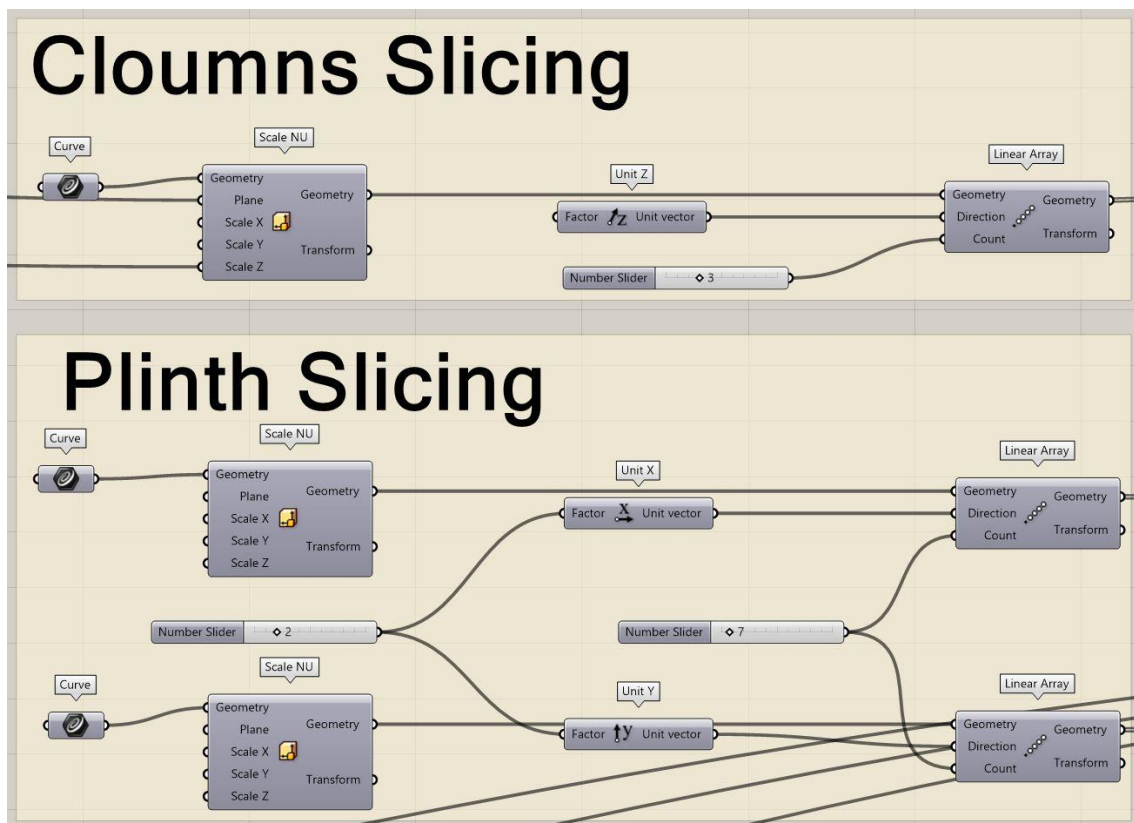

A screenshot showing the columns and plinth Slicing techniques

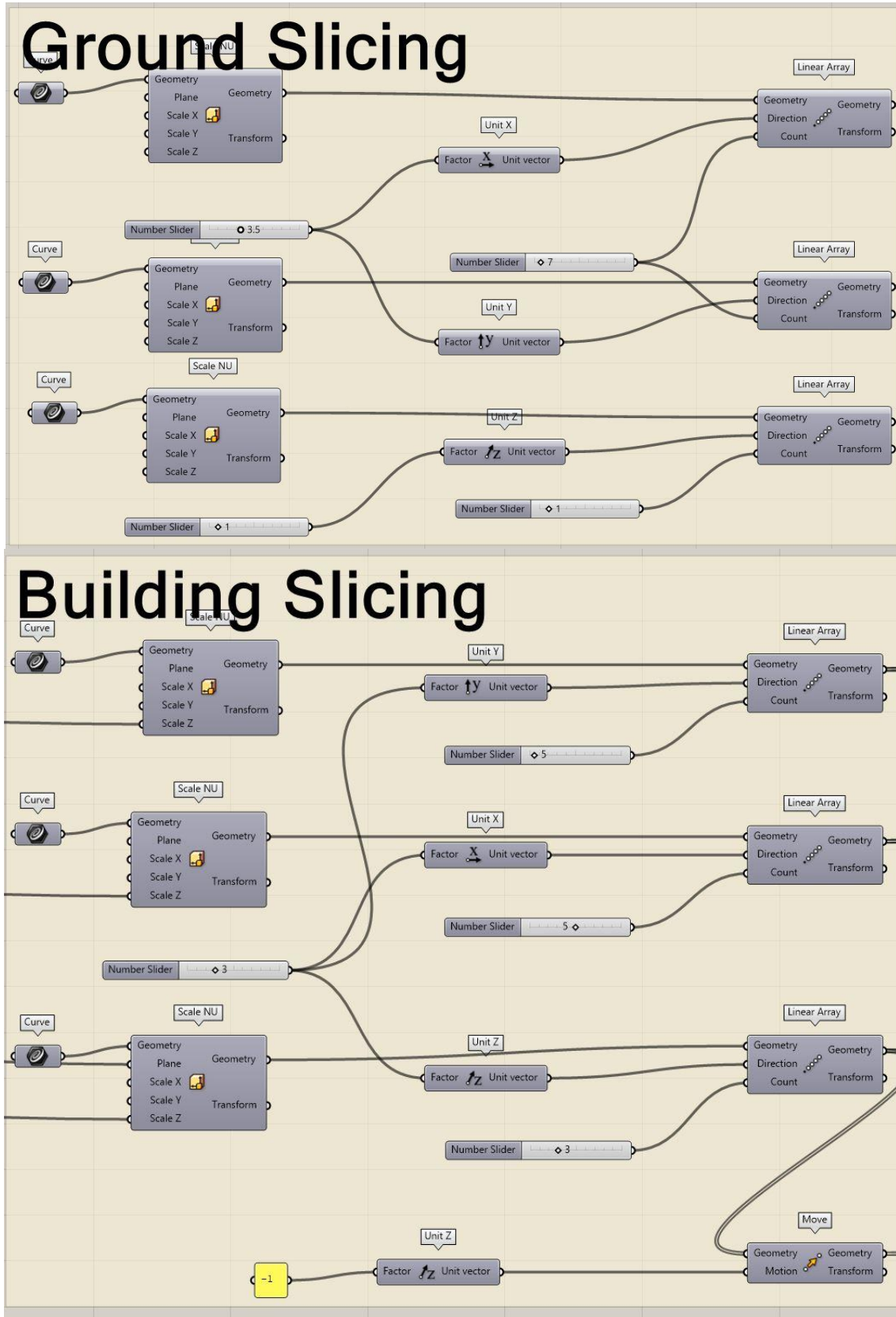

A screenshot showing the ground and building Slicing techniques

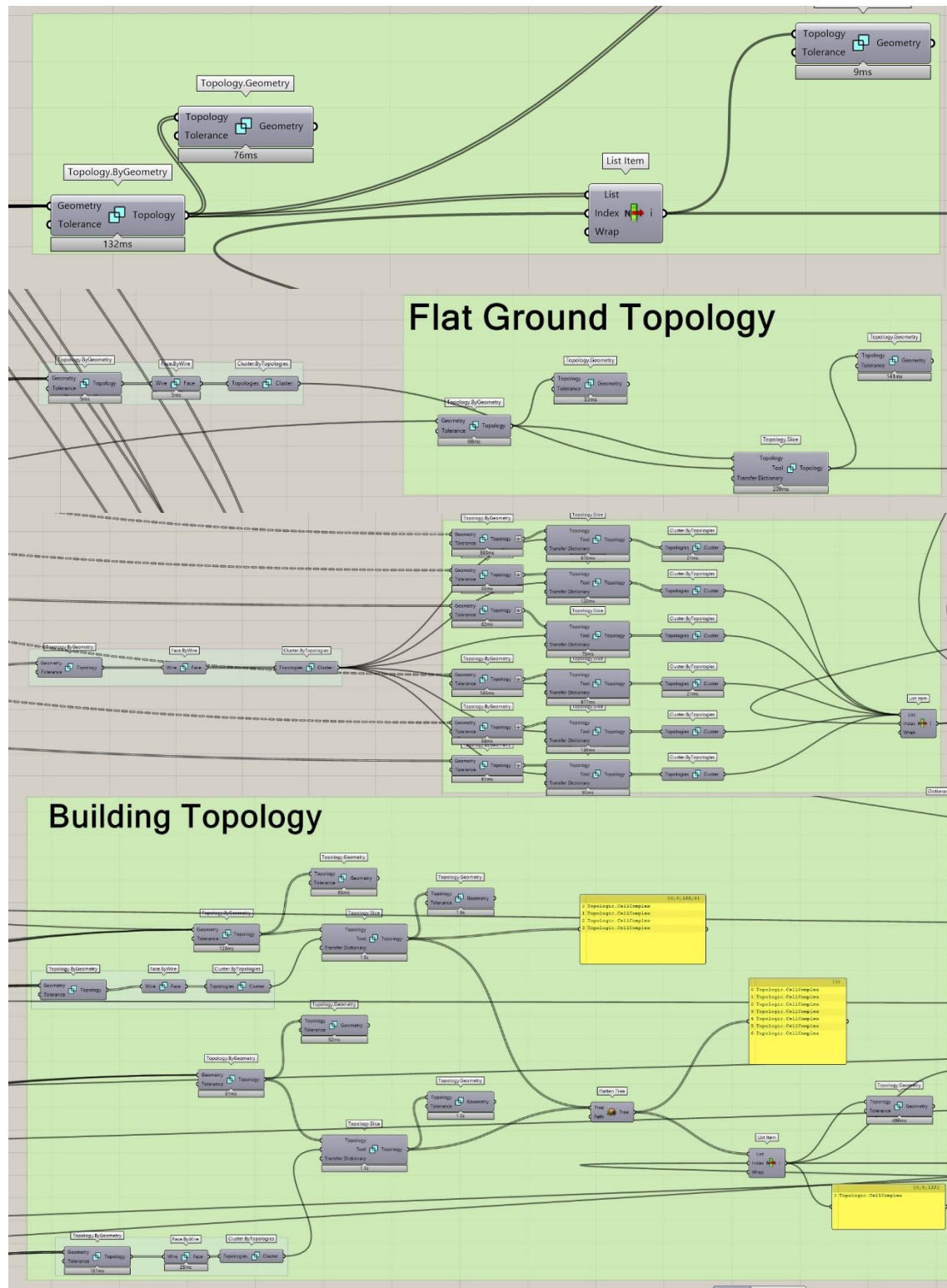

A screenshot showing the way of transferring geometries to Topology, starting with the building, columns, ground and core

Appendix

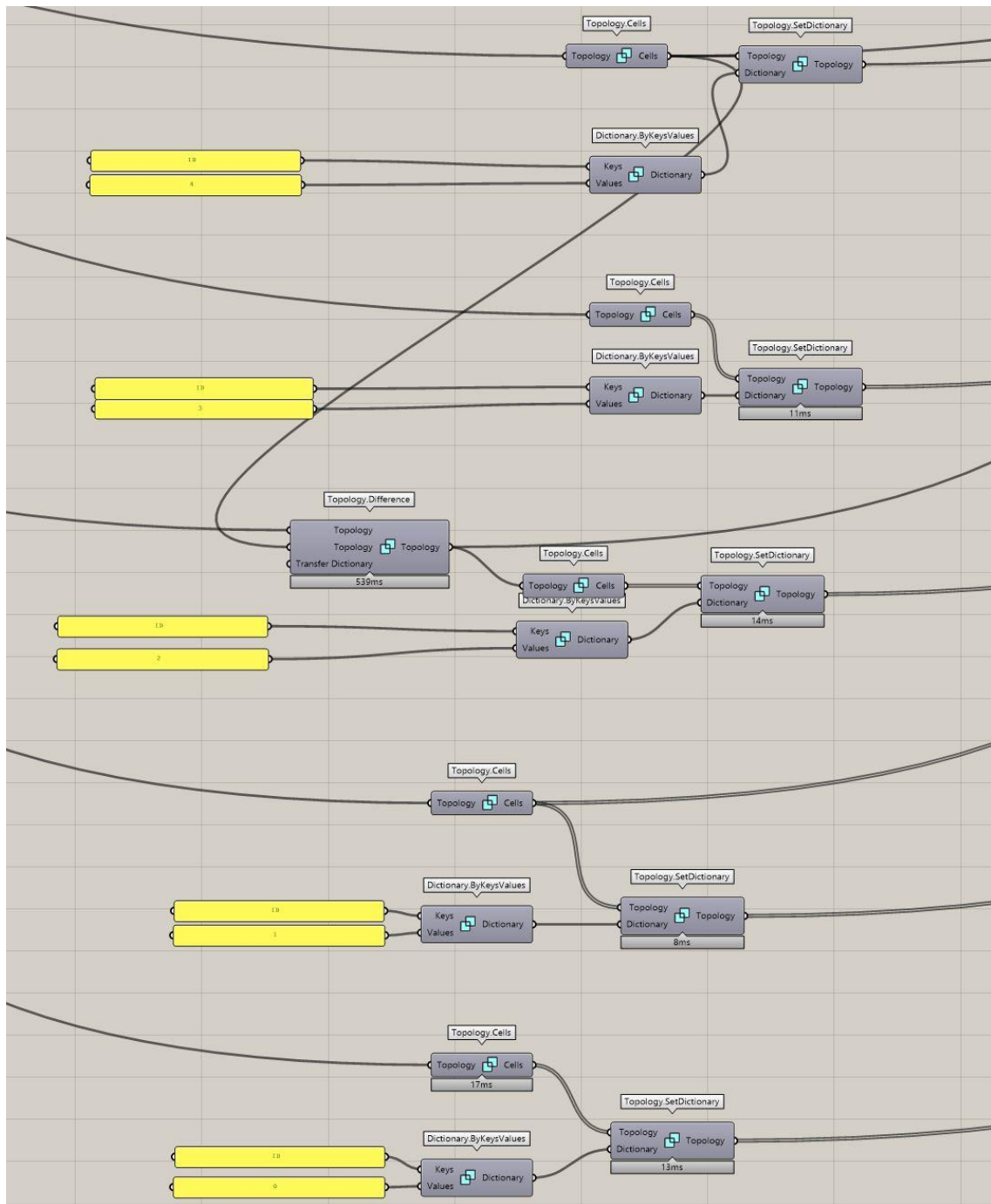

A screenshot showing the assigned "ID" to the dictionary

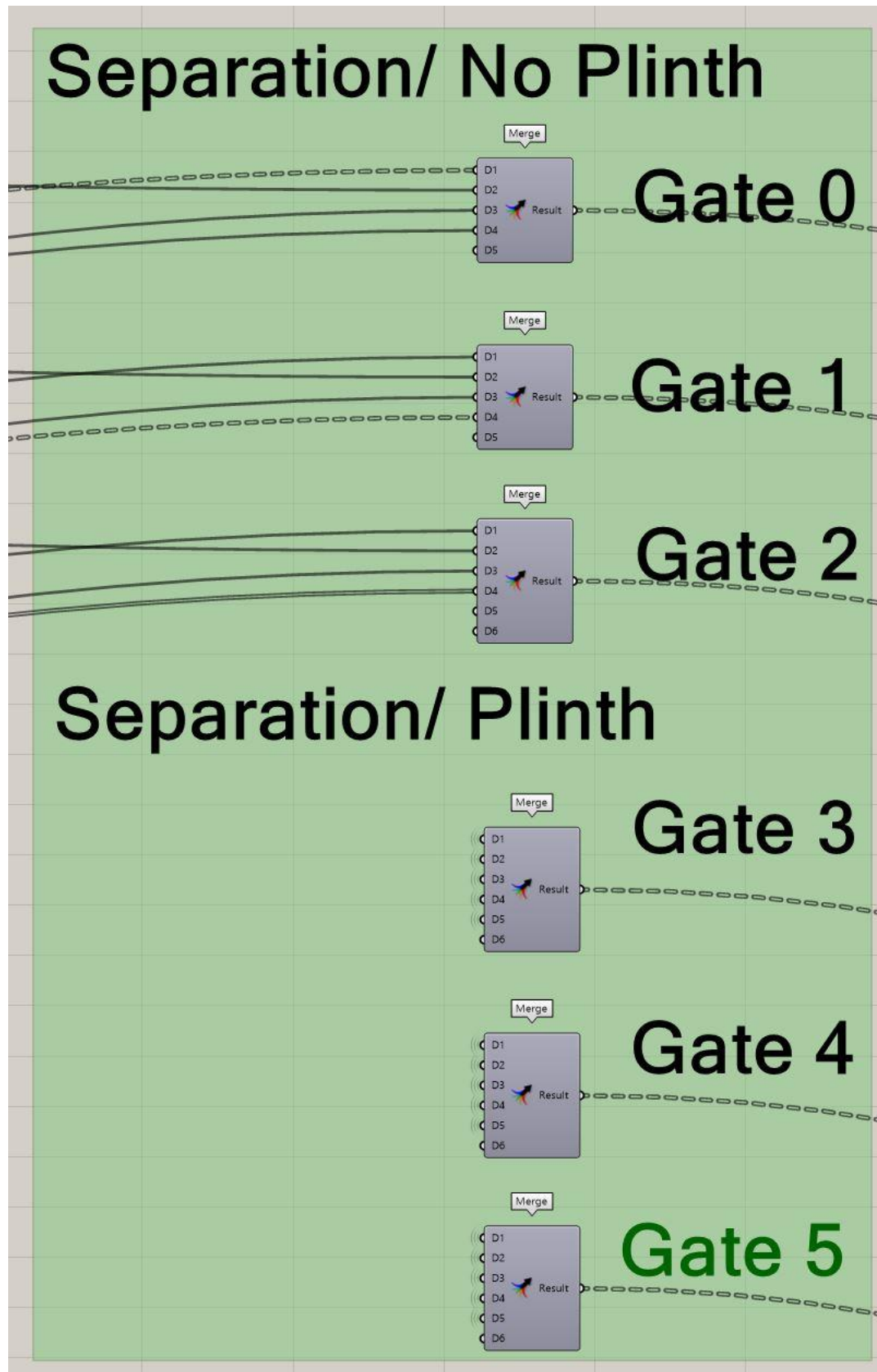

A screenshot showing all geometries elements that merged in gates based on the different relationship approaches.

Appendix

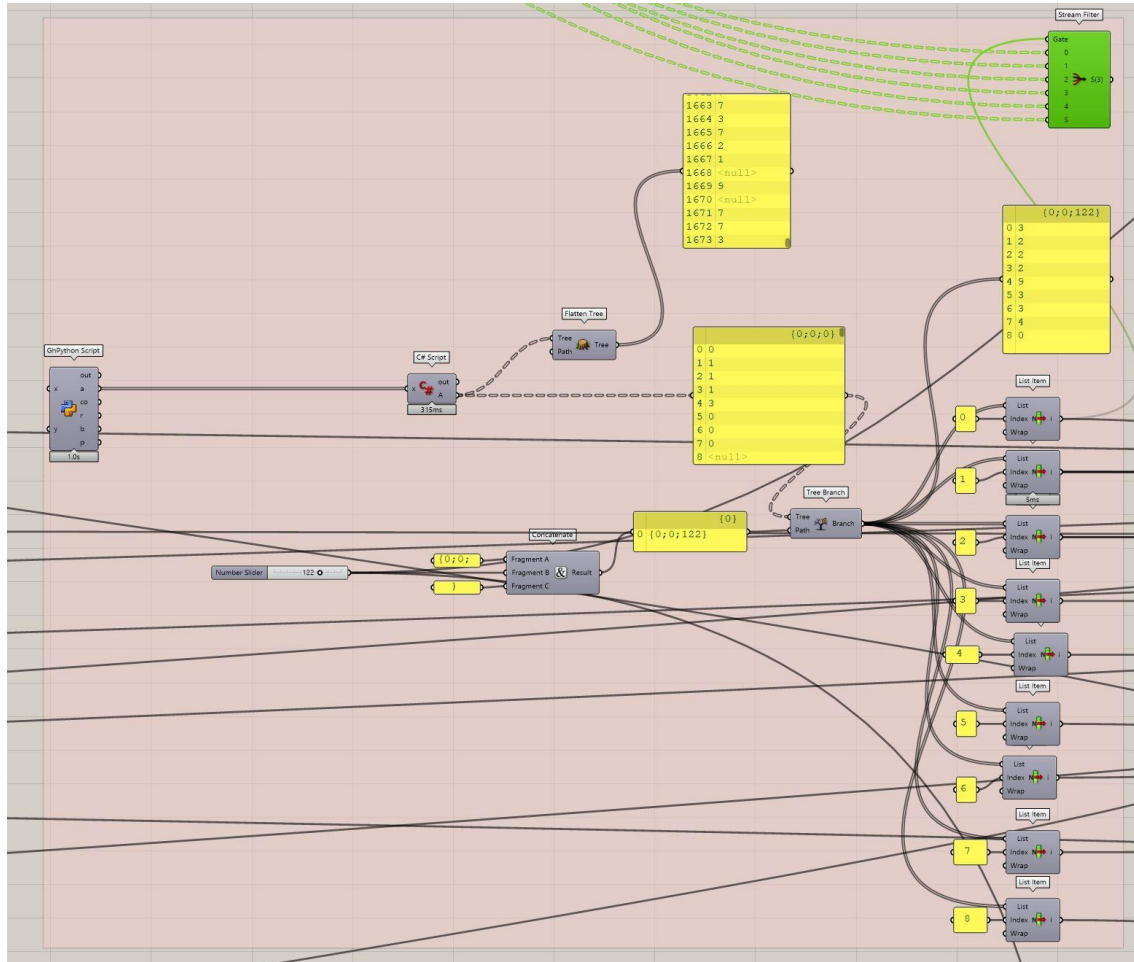

A screenshot showing python scripts that are used to run the loops of all the possible iterations

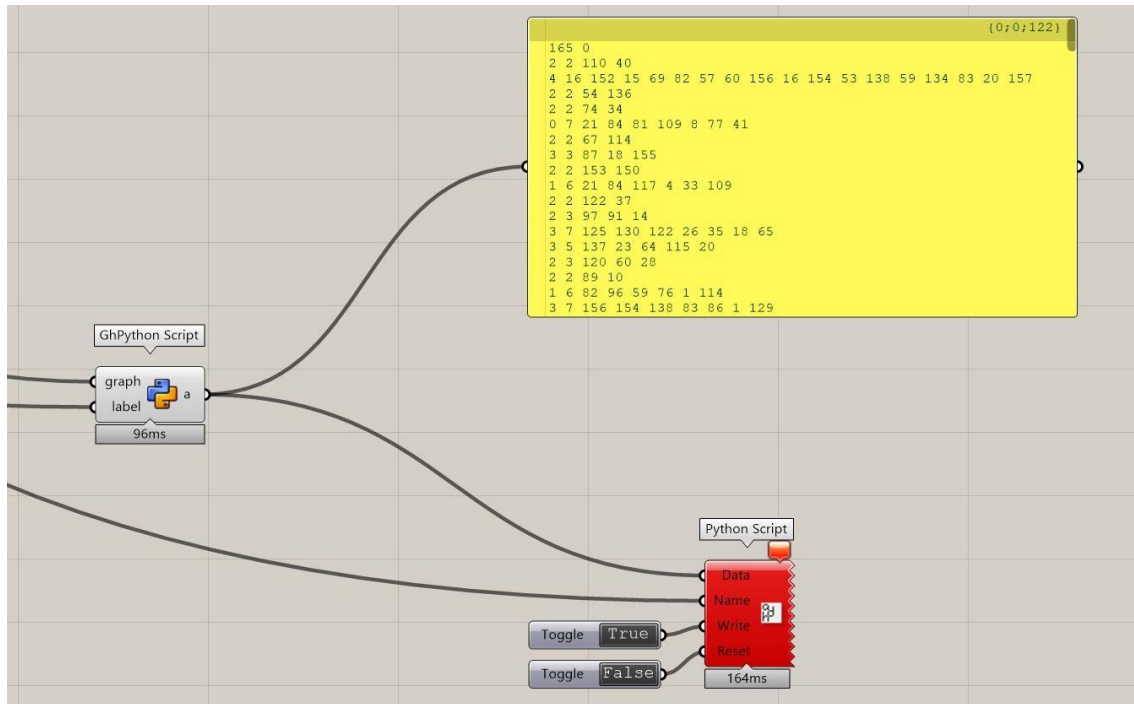

A screenshot showing a produced text file in the Grasshopper "panel", then the way of saving this text file using a python script

Appendix

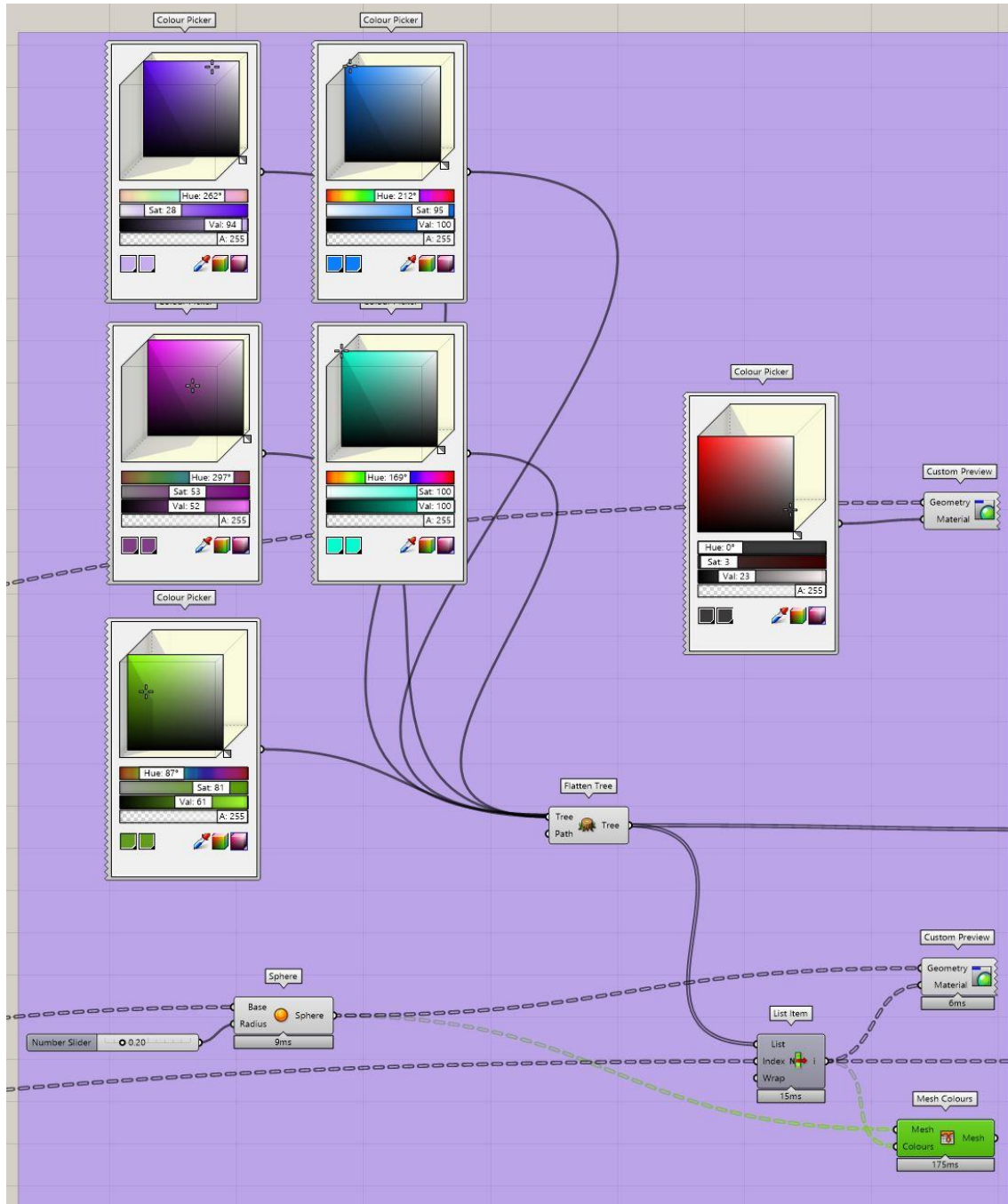

A screenshot showing of the representing/Rendering of all graph in different colored.

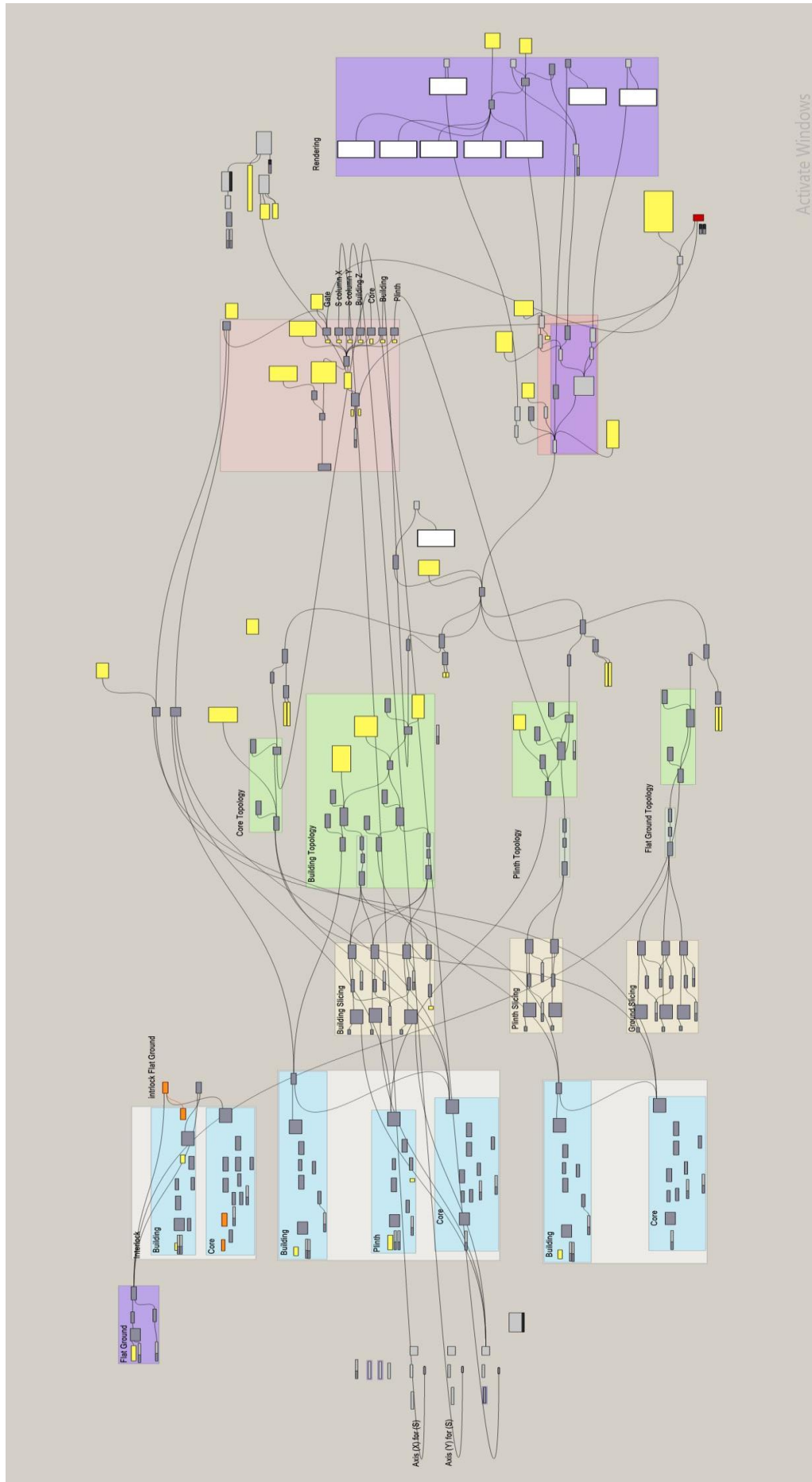

A screenshot showing an example of the workflow of generated interlock iterations

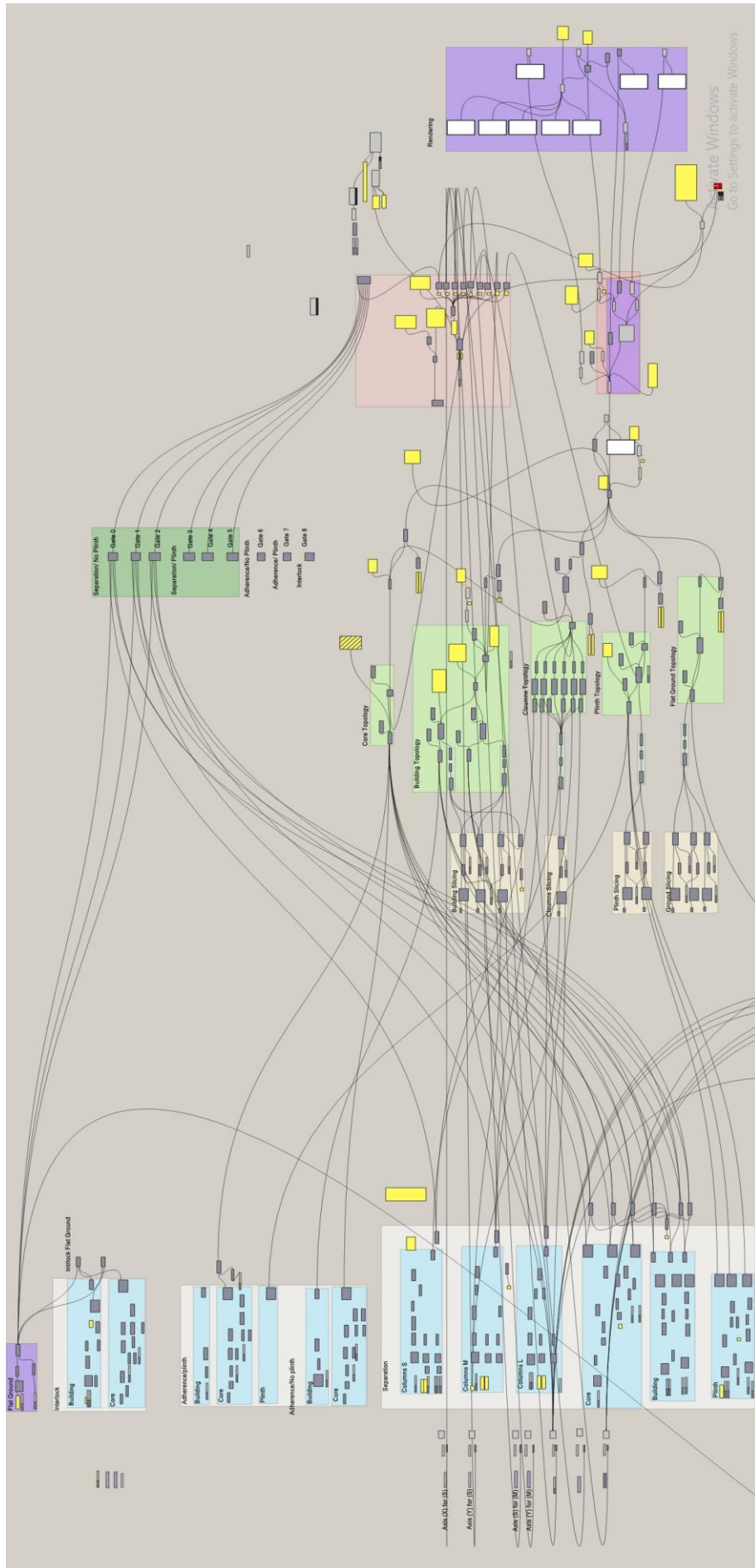

A screenshot showing an example of the workflow of generated separation iterations

Appendix: X
Generated 3D Topological (BGR) Dataset

Separation on Flat Ground

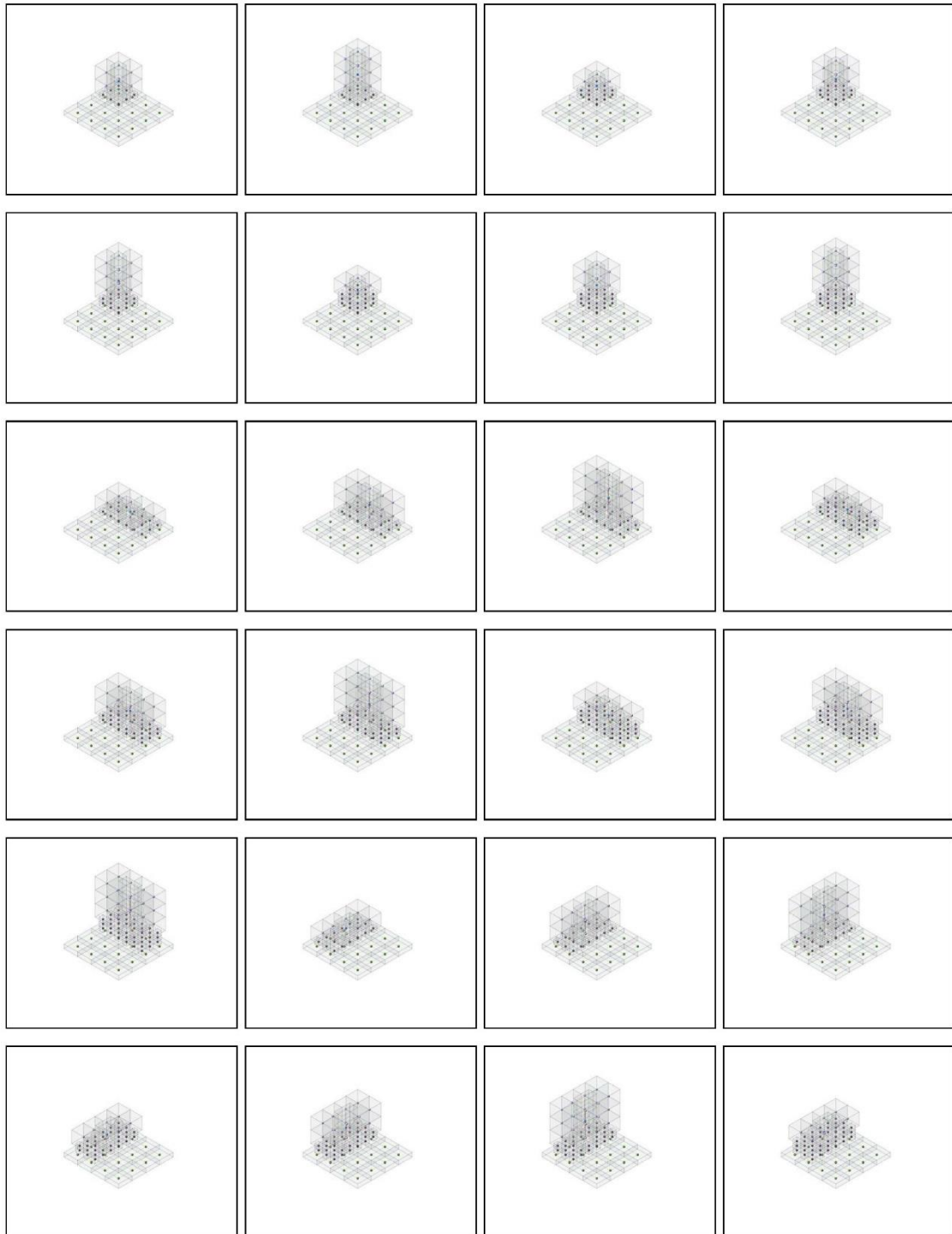

Separation on Flat Ground

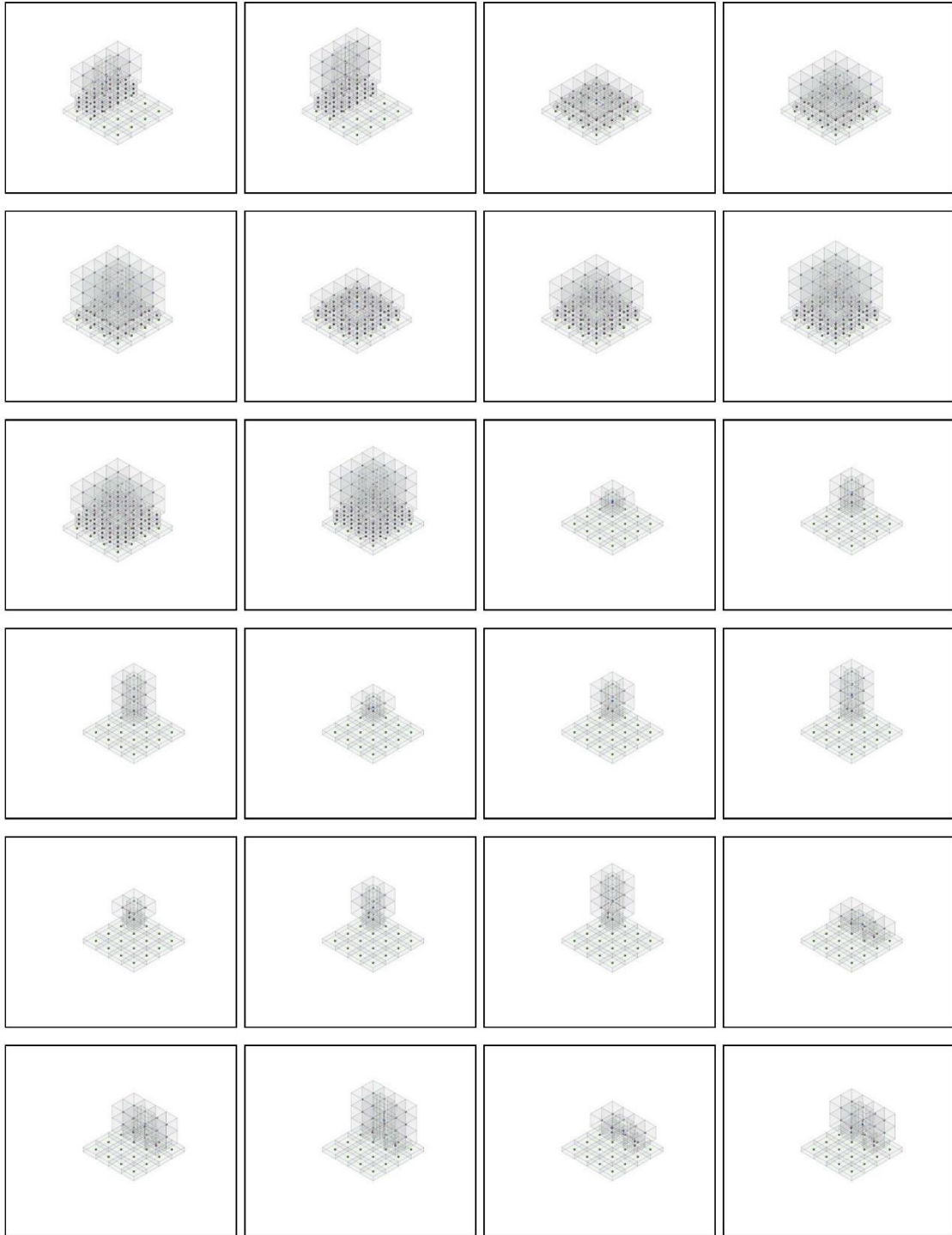

Separation on Flat Ground



Separation with Plinth on Flat Ground

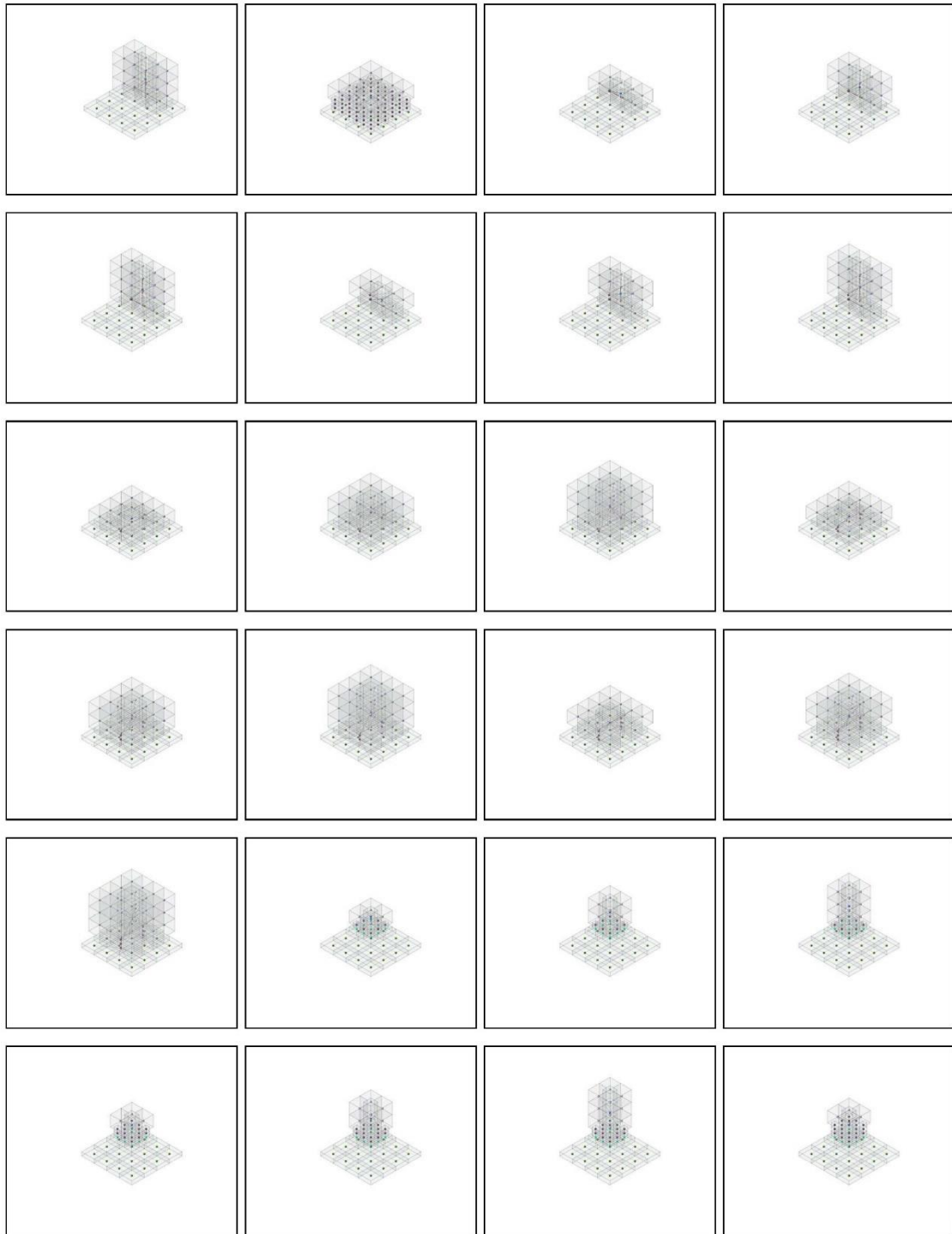

Separation with Plinth on Flat Ground

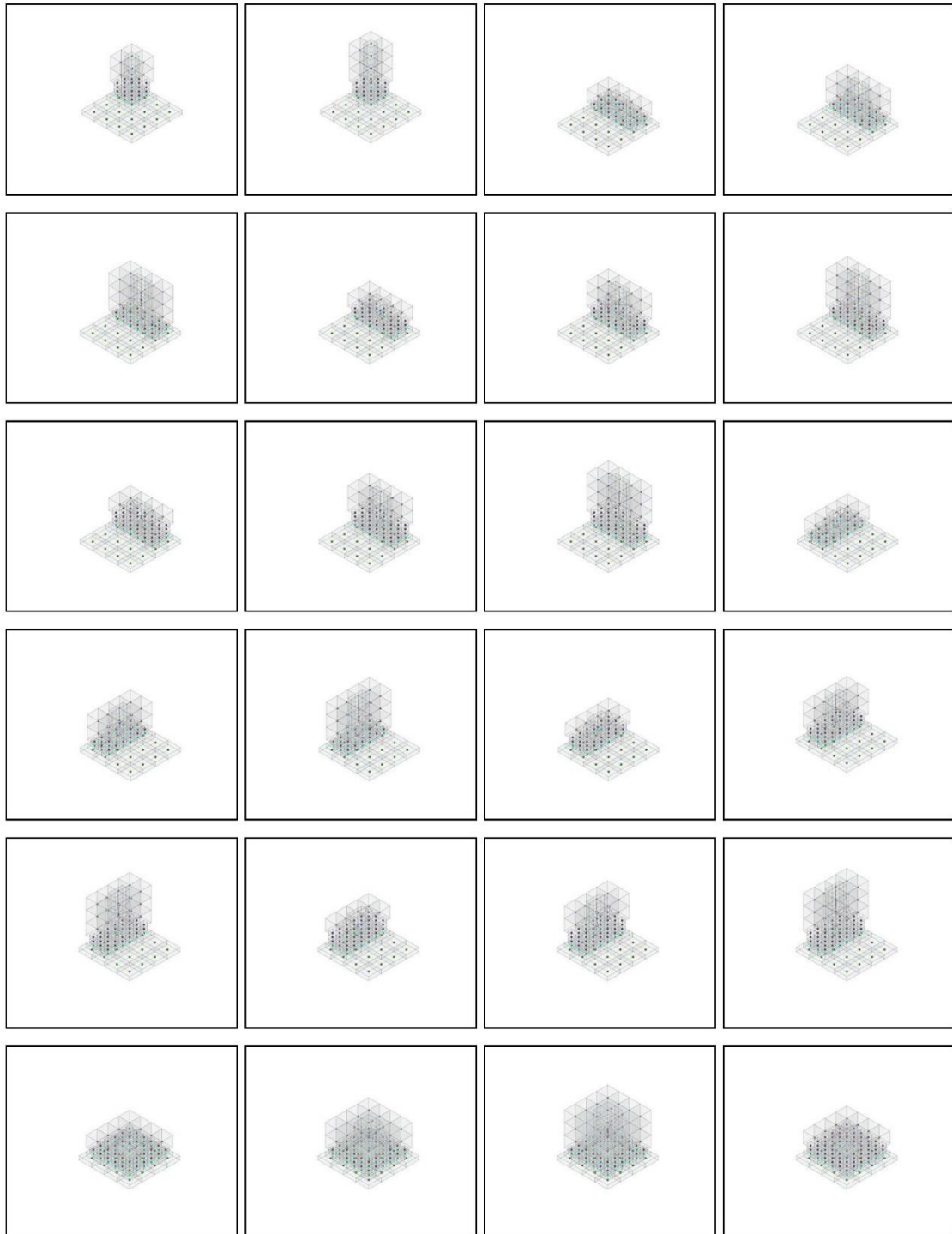

Appendix

Separation with Plinth on Flat Ground

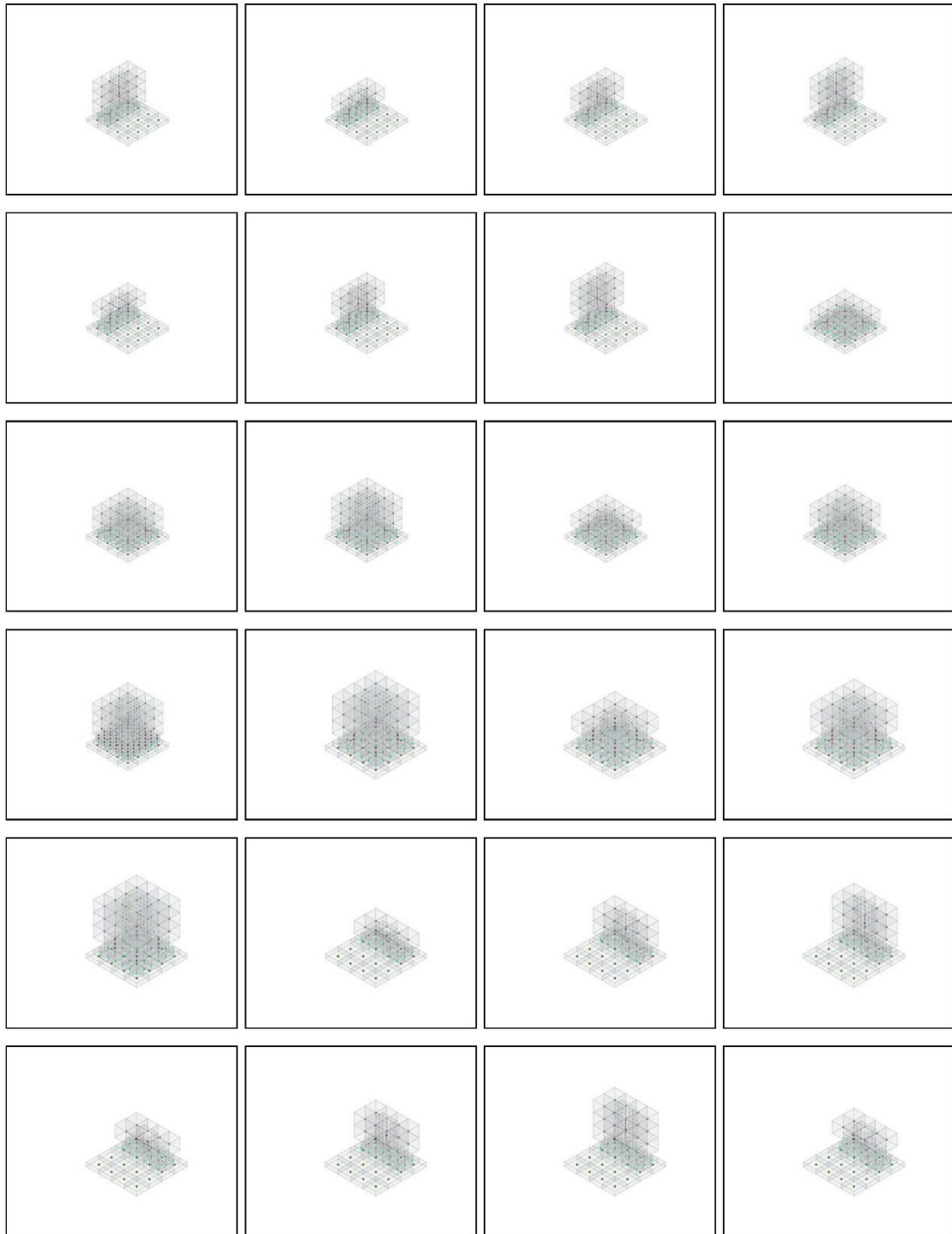

Appendix

Separation with Plinth on Flat Ground

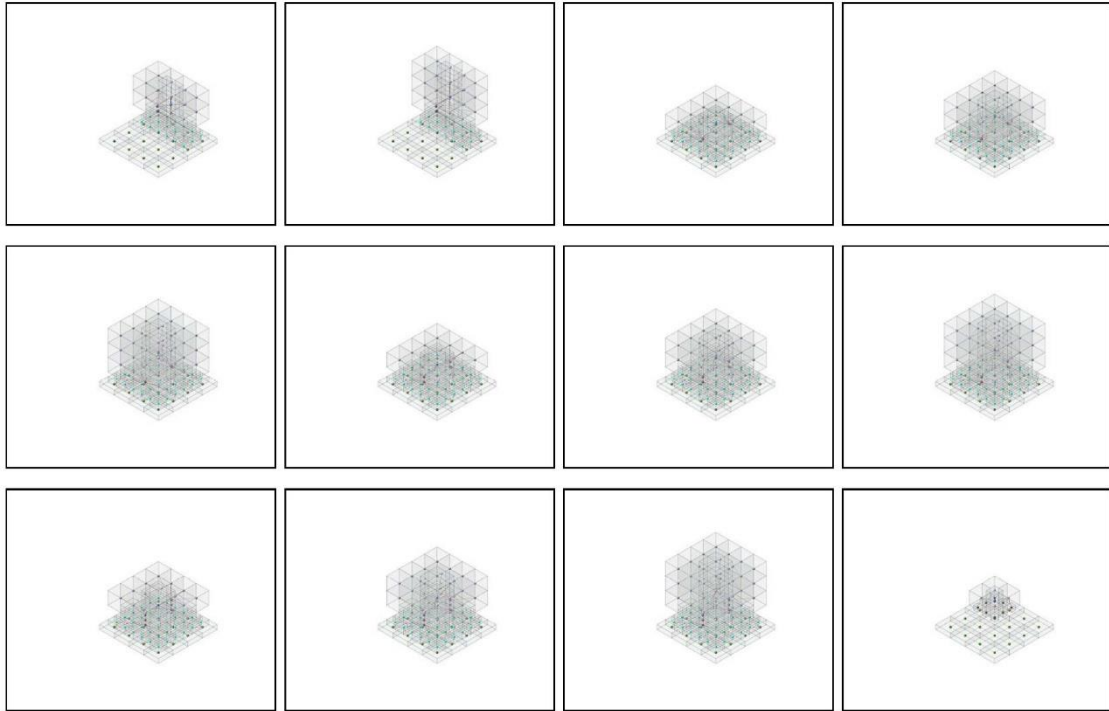

Adherence / Adherence with Plinth on Flat Ground

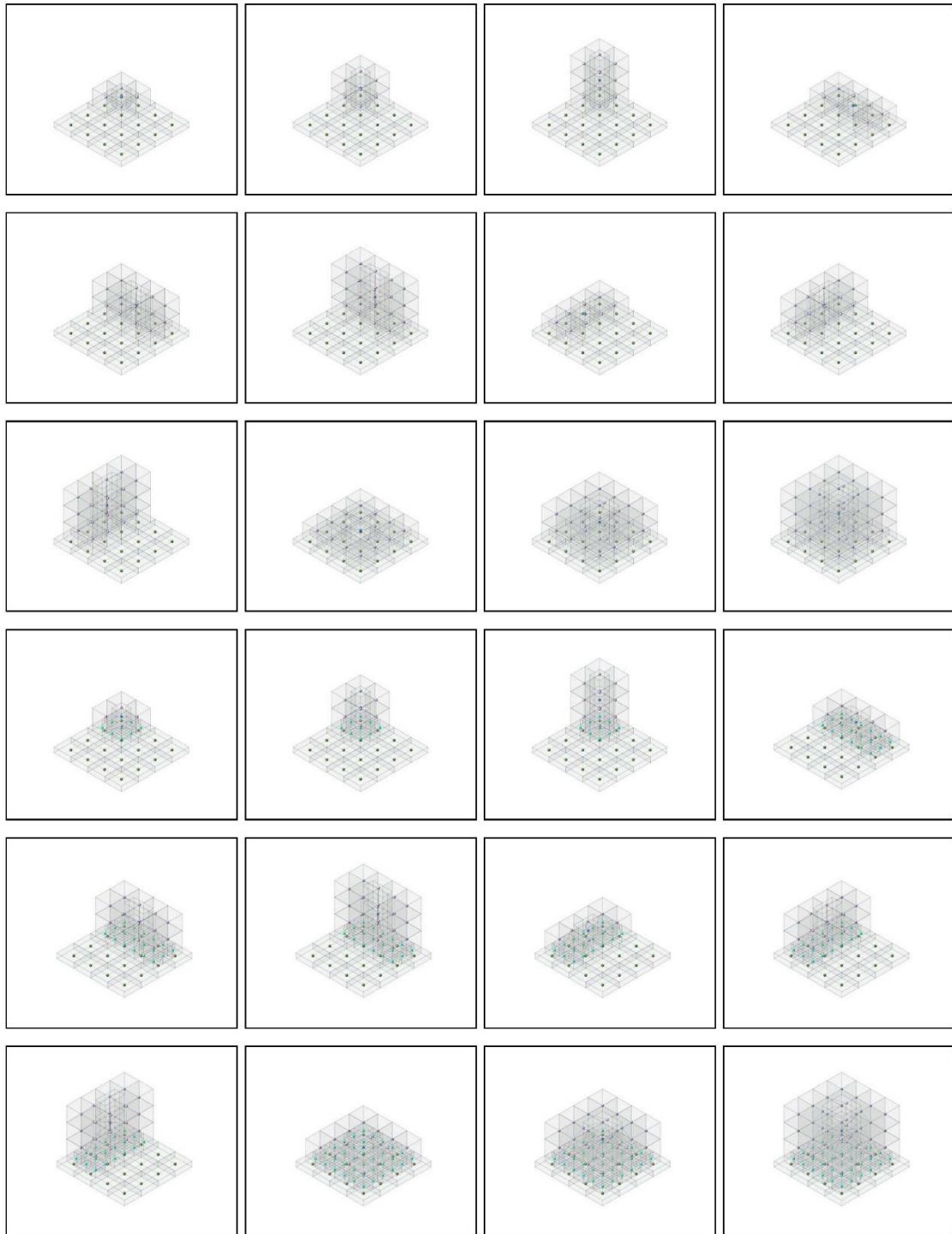

Interlock on Flat Ground

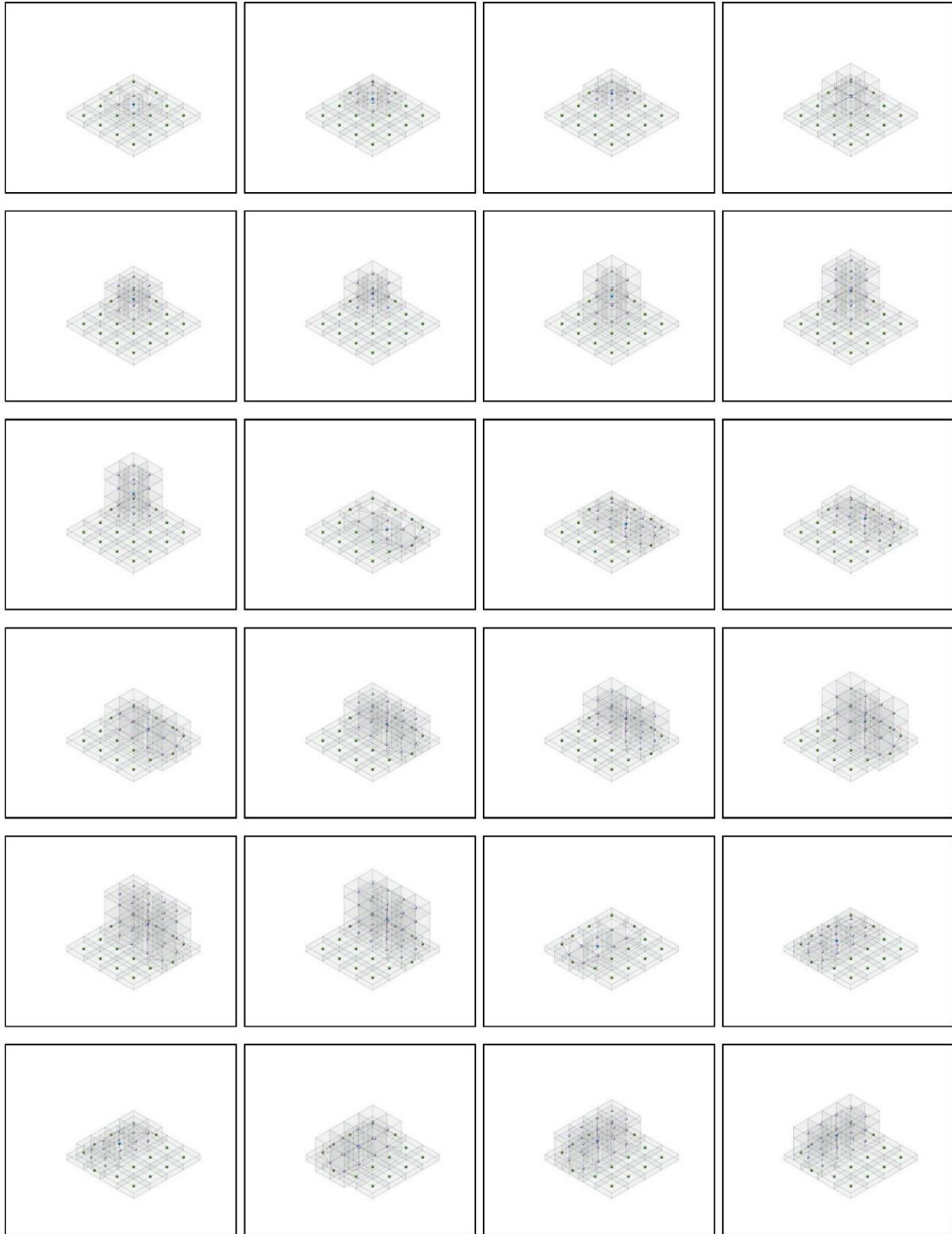

Appendix

Interlock on Flat Ground

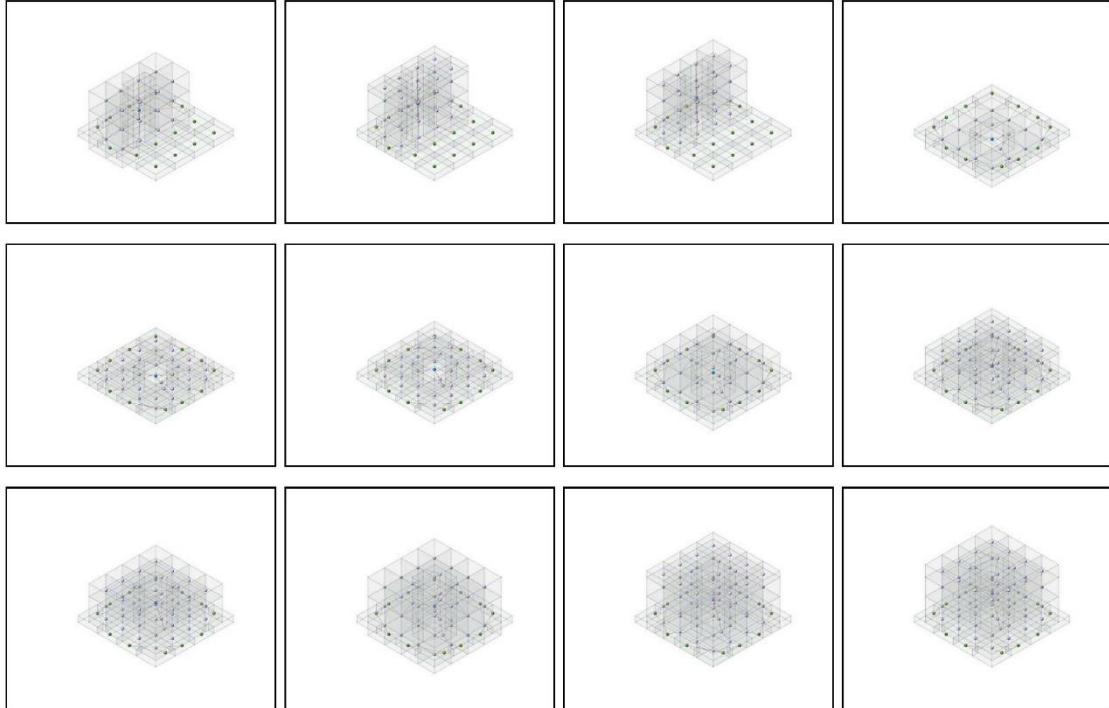

Separation on Sloped Ground

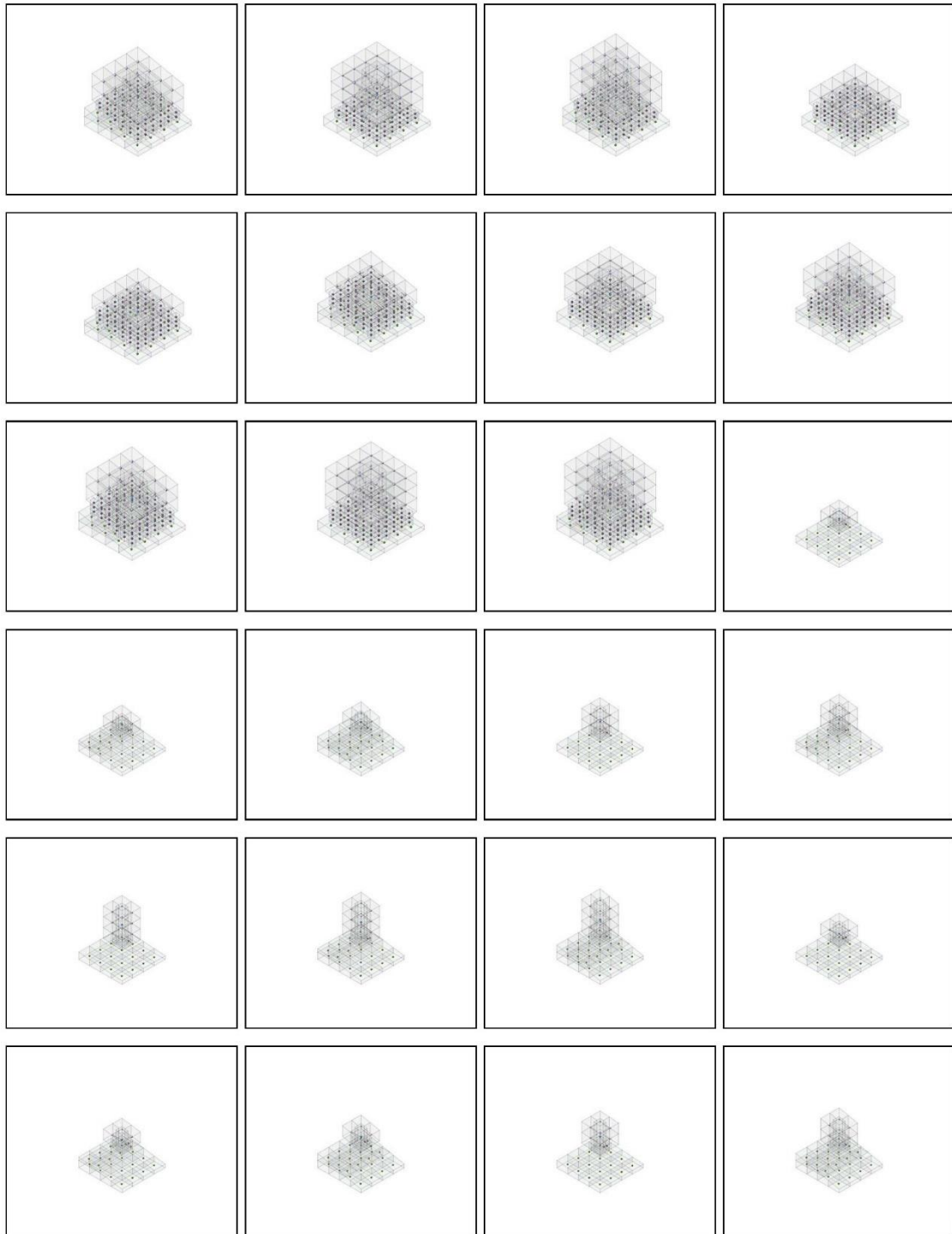

Separation on Sloped Ground

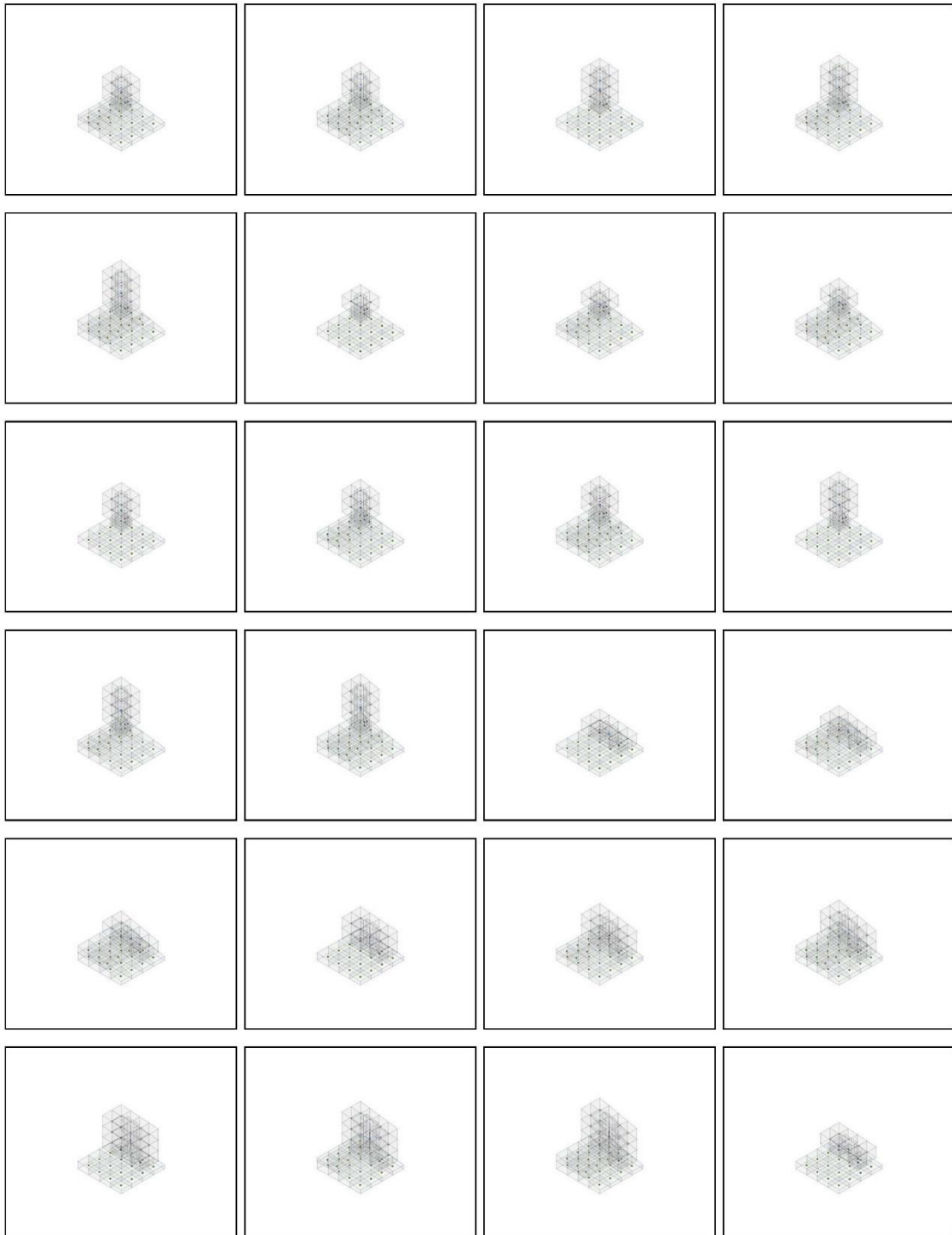

Separation on Sloped Ground

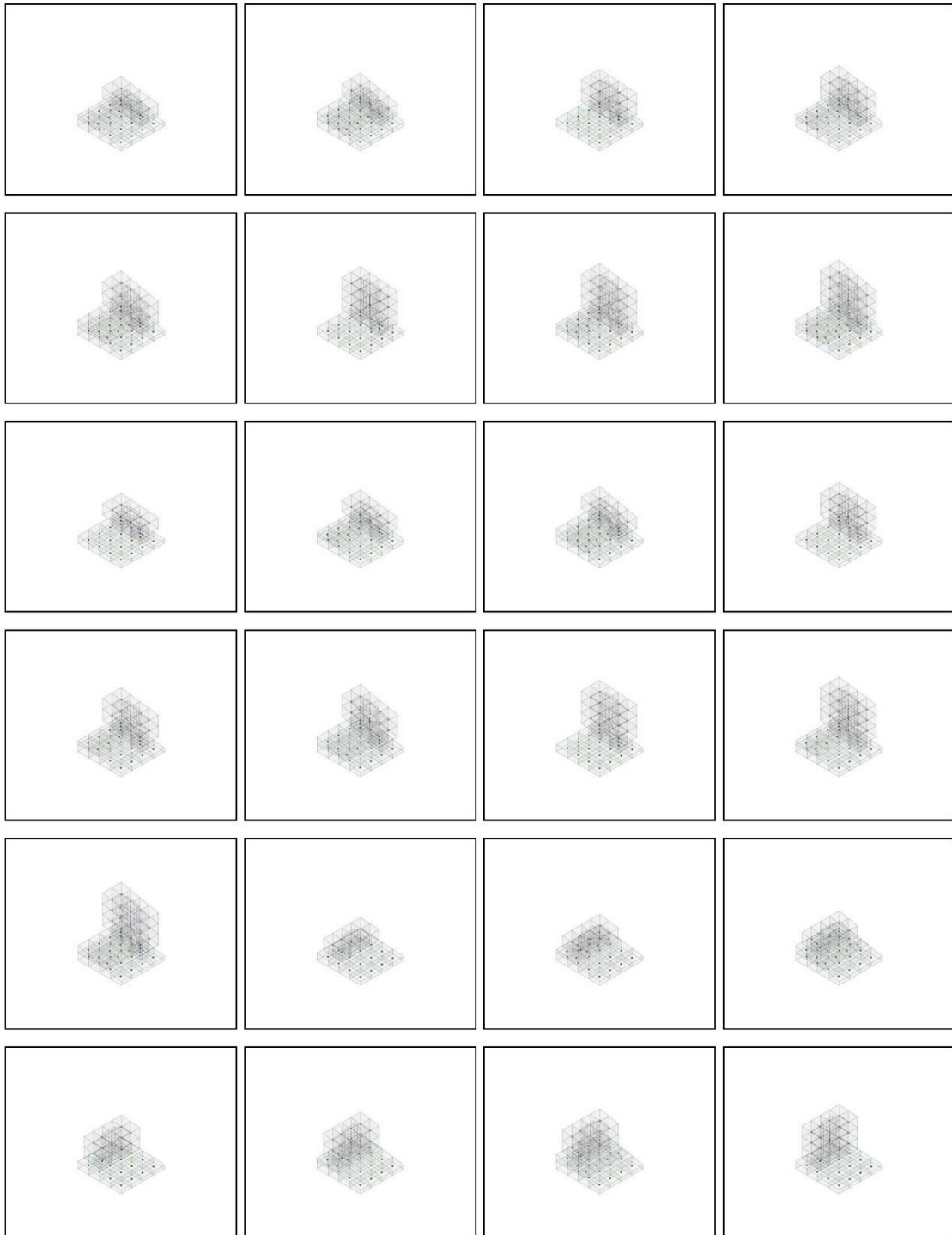

Appendix

Separation on Sloped Ground

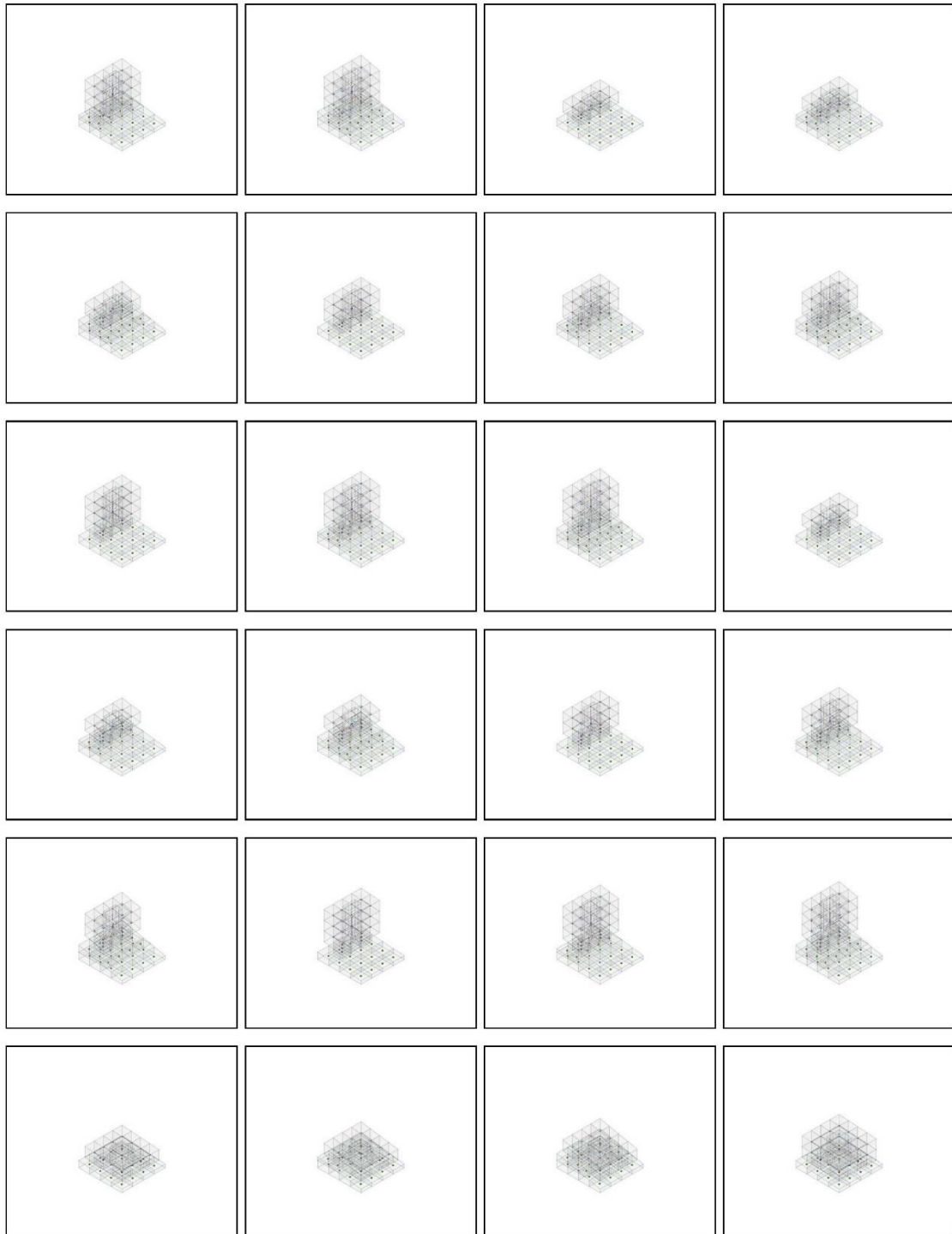

Separation on Sloped Ground

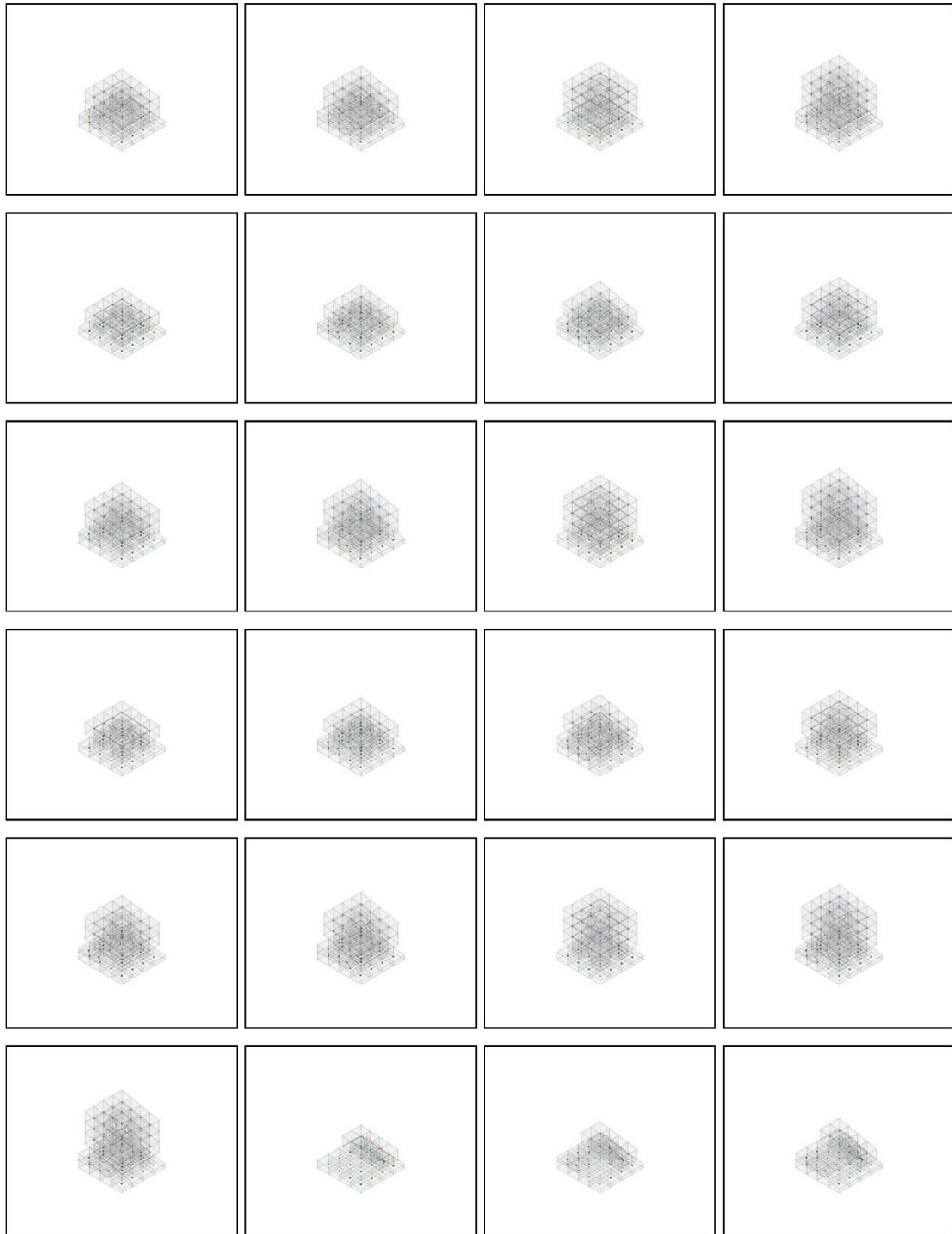

Separation on Sloped Ground

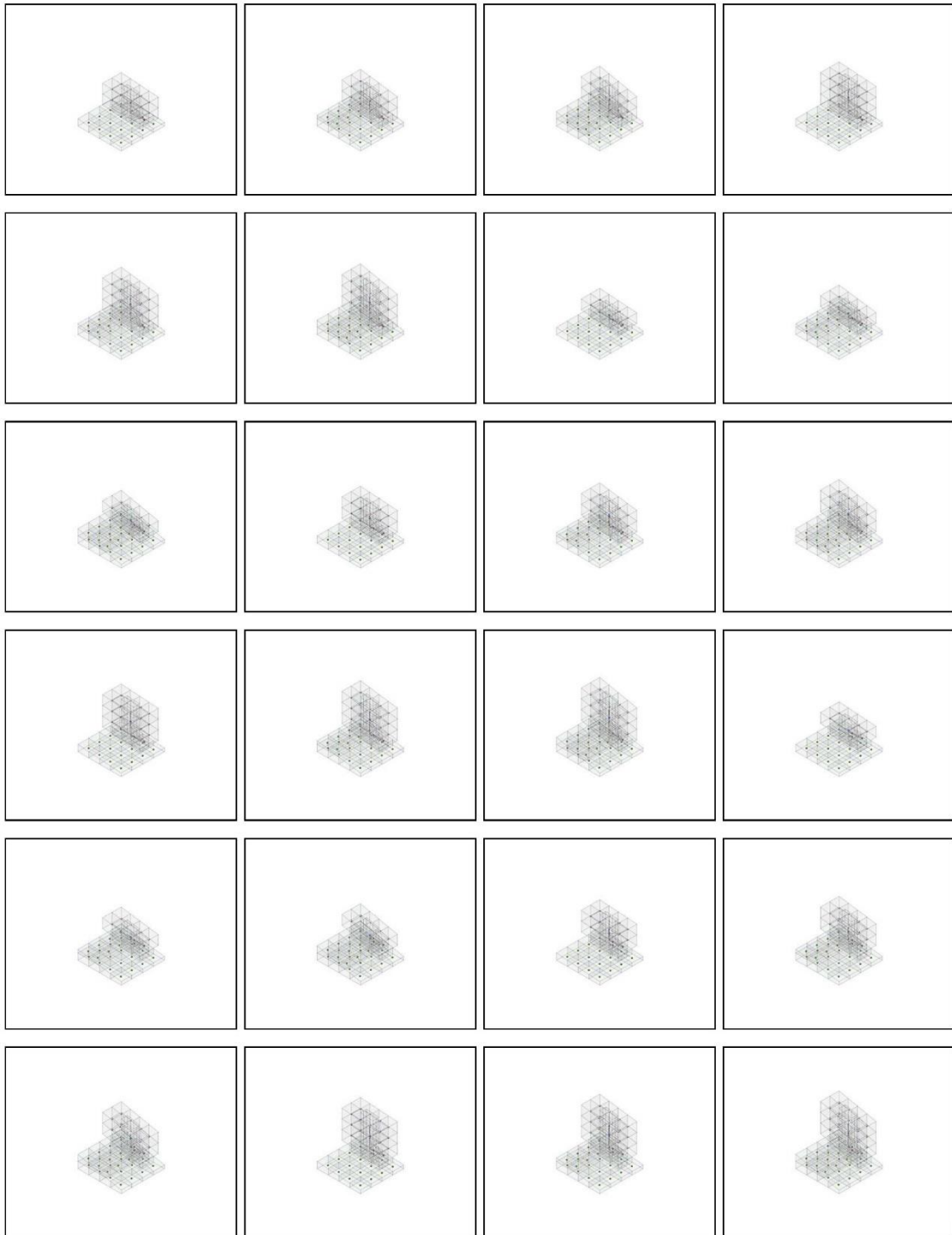

Separation on Sloped Ground



Separation with Plinth on Sloped Ground

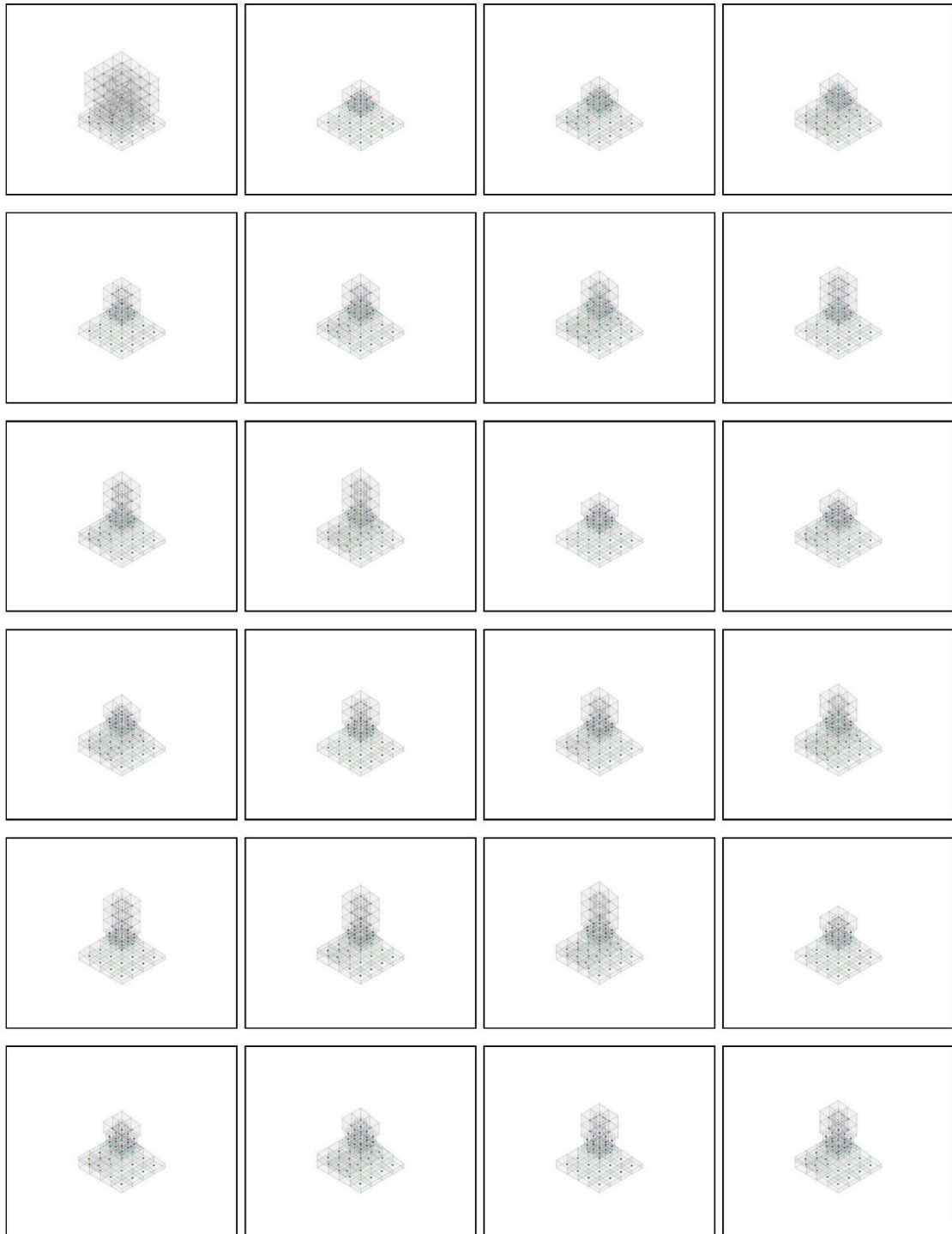

Separation with Plinth on Sloped Ground

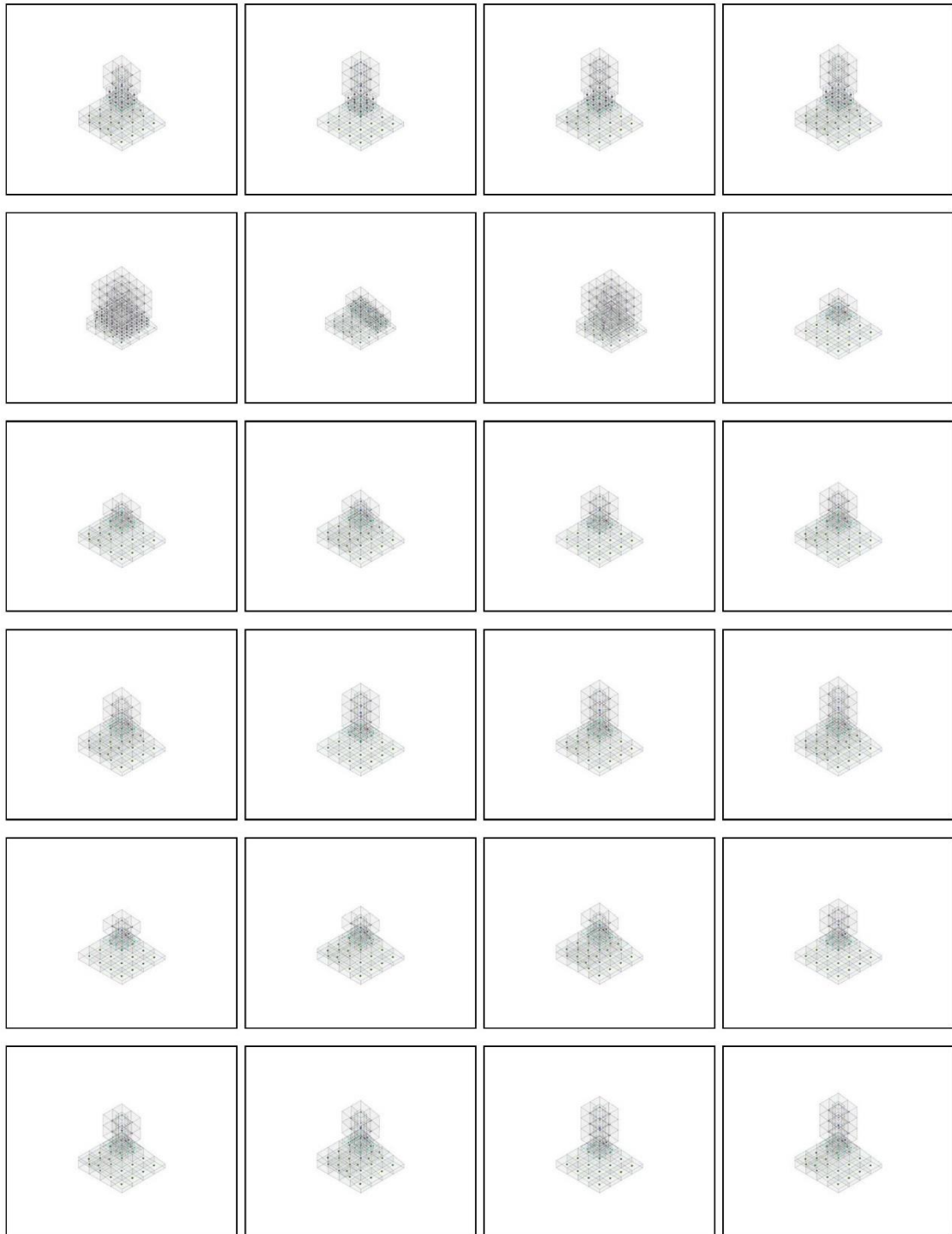

Separation with Plinth on Sloped Ground

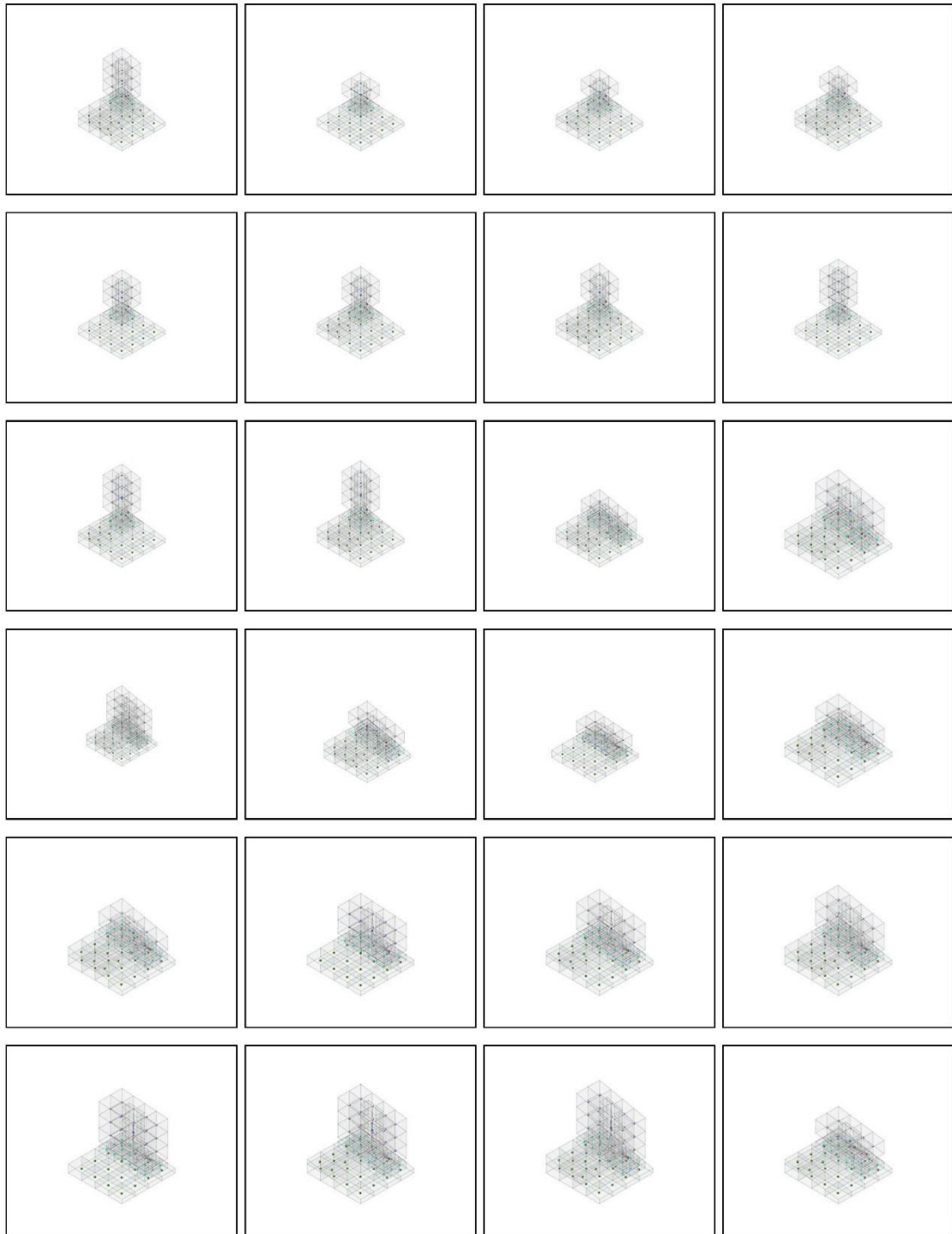

Separation with Plinth on Sloped Ground

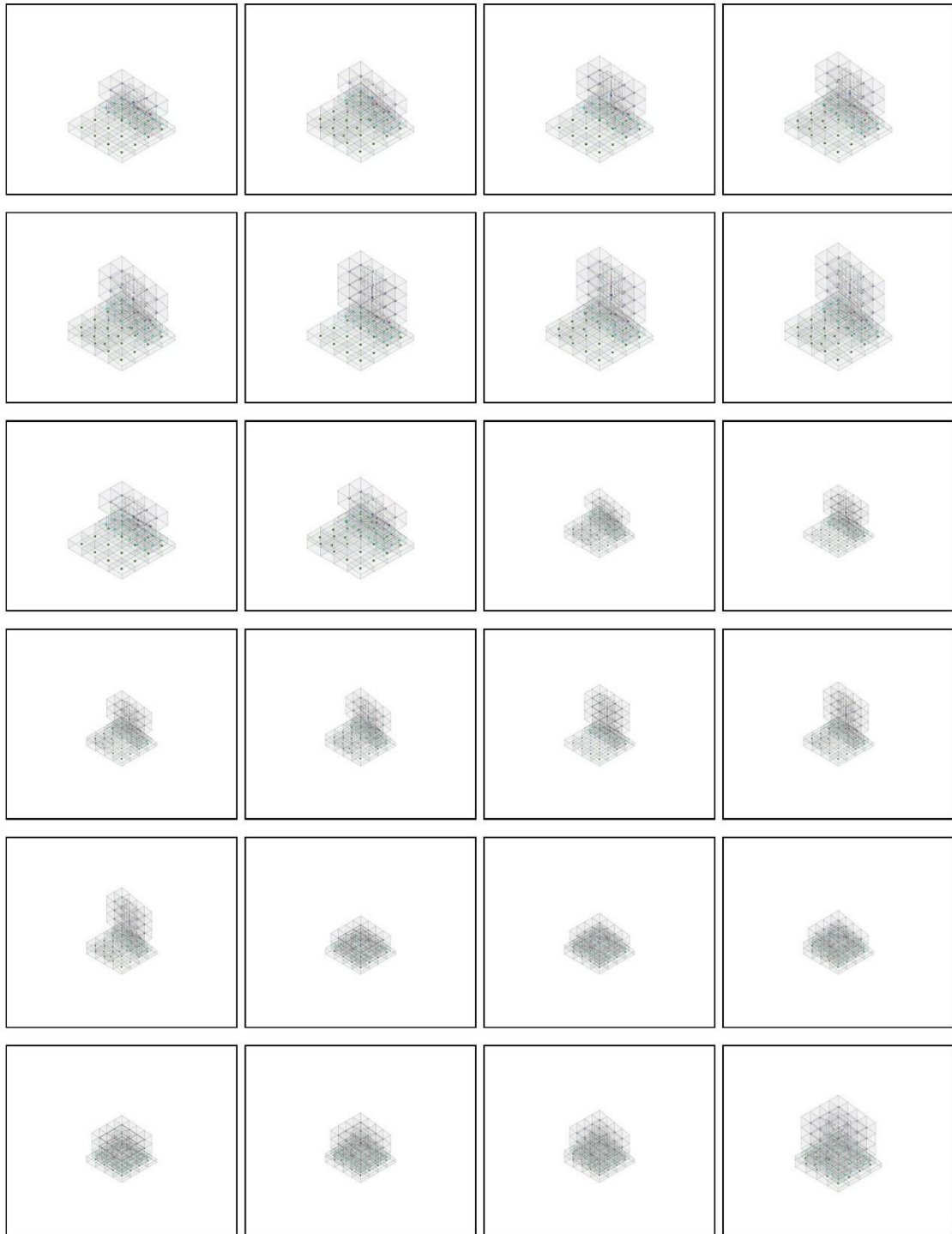

Separation with Plinth on Sloped Ground

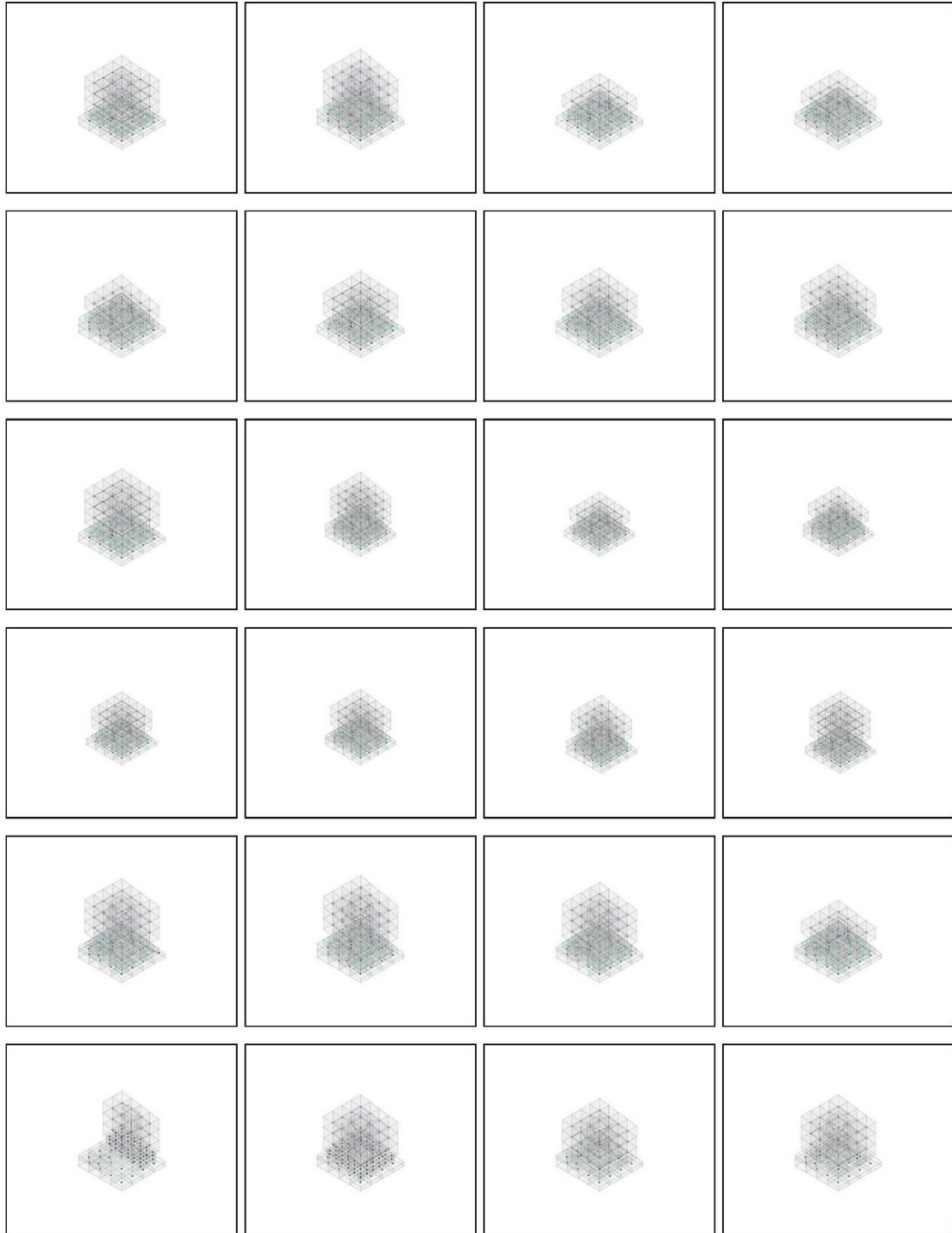

Separation with Plinth on Sloped Ground



Separation with Plinth on Sloped Ground

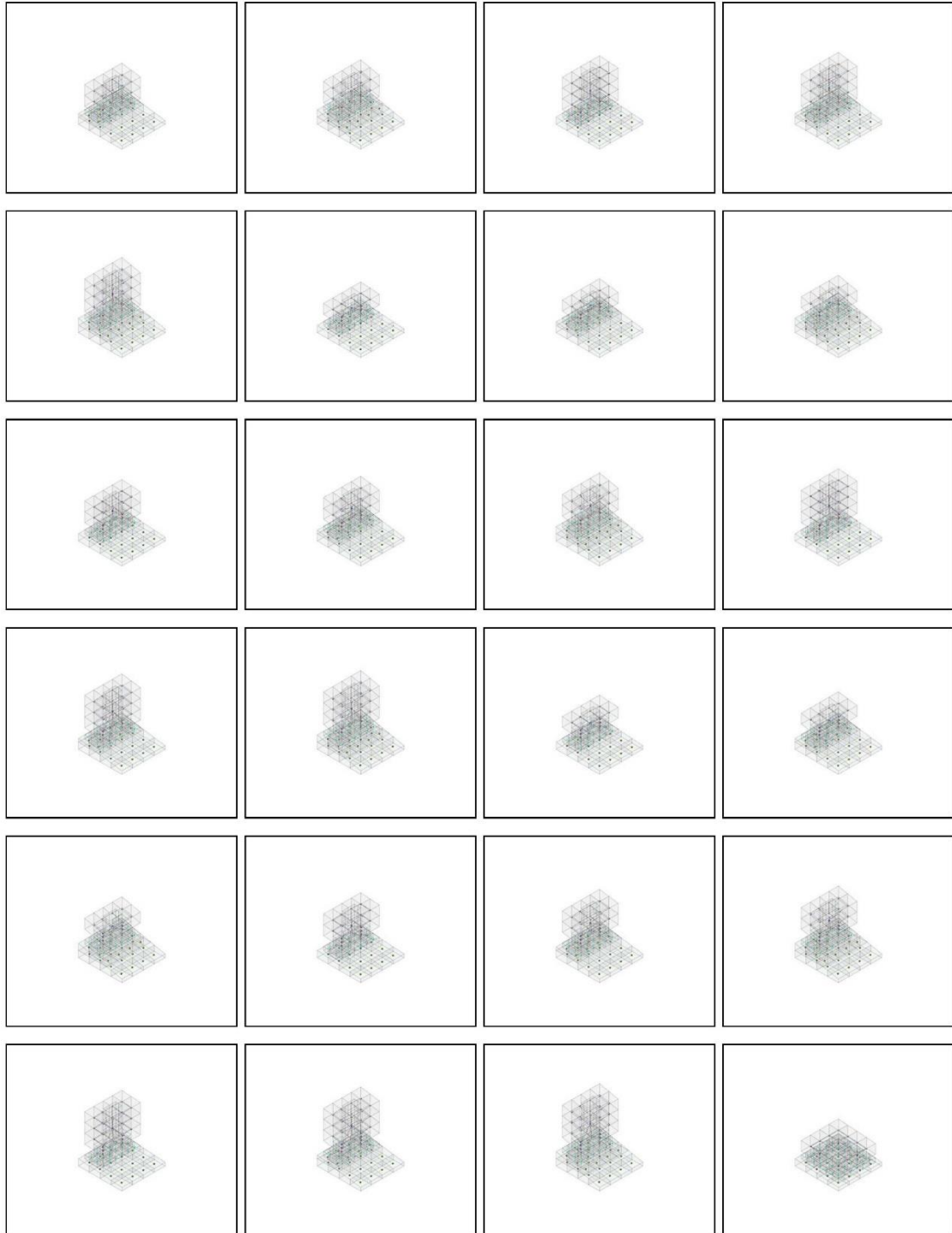

Separation with Plinth on Sloped Ground



Separation with Plinth on Sloped Ground

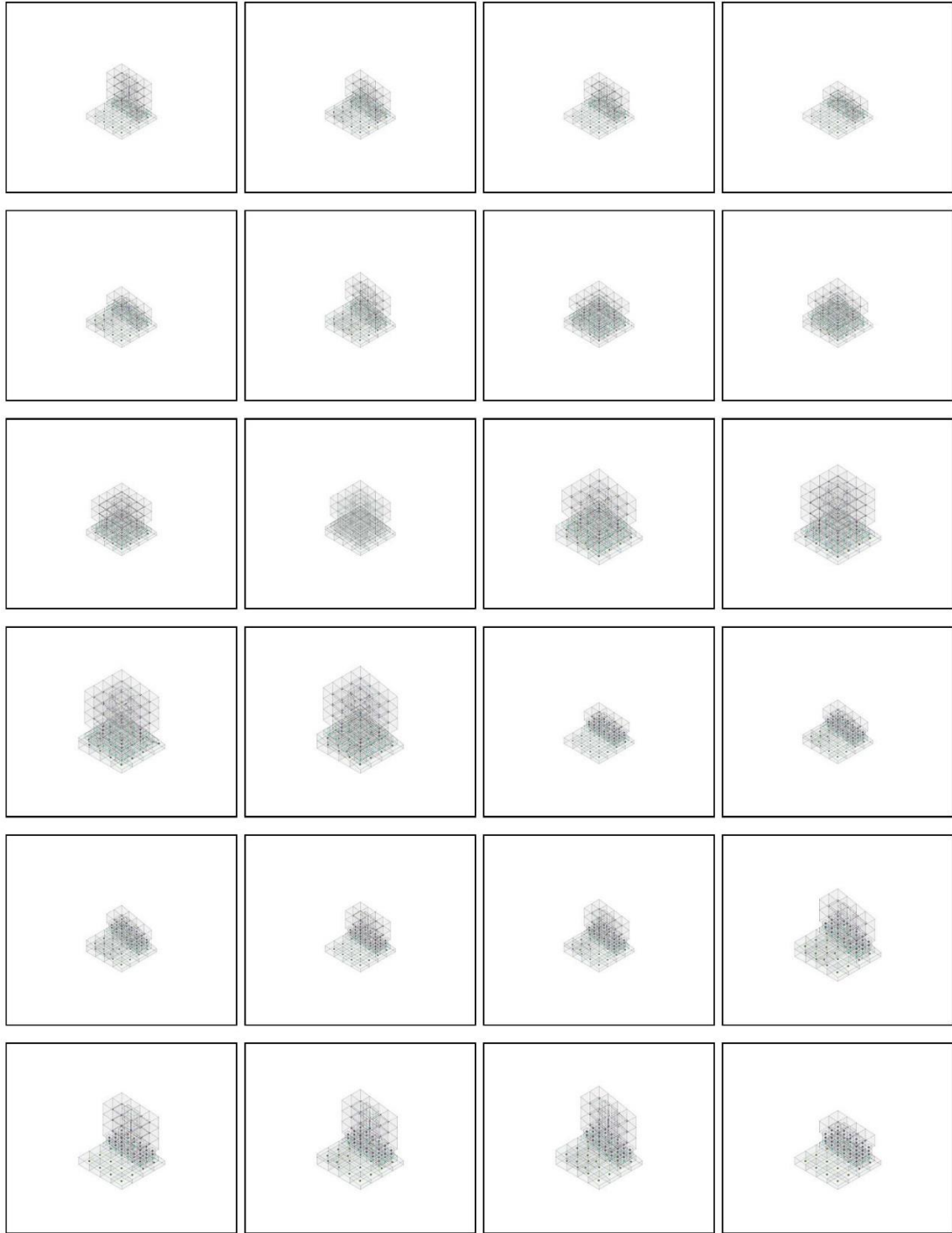

Separation with Plinth on Sloped Ground

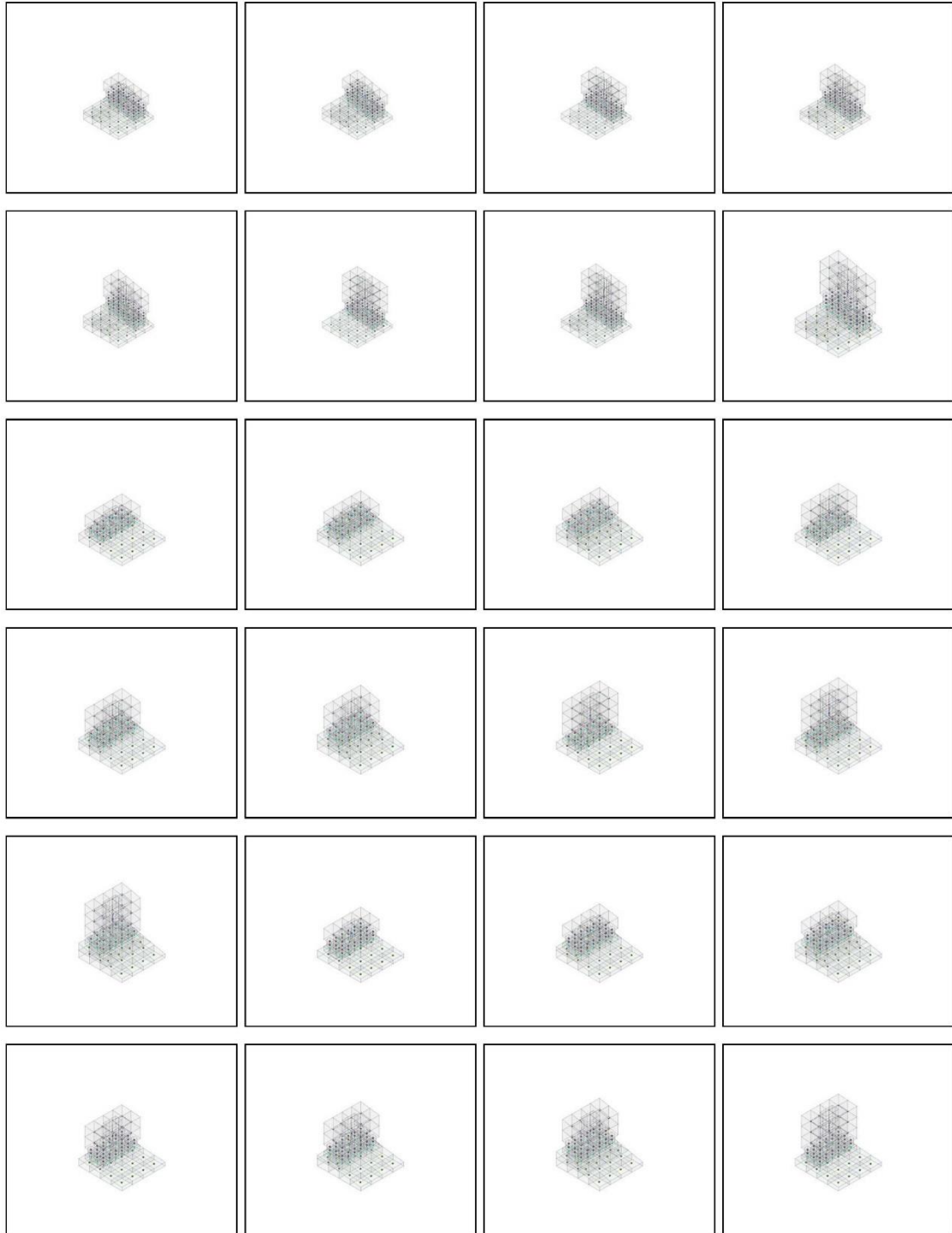

Separation with Plinth on Sloped Ground

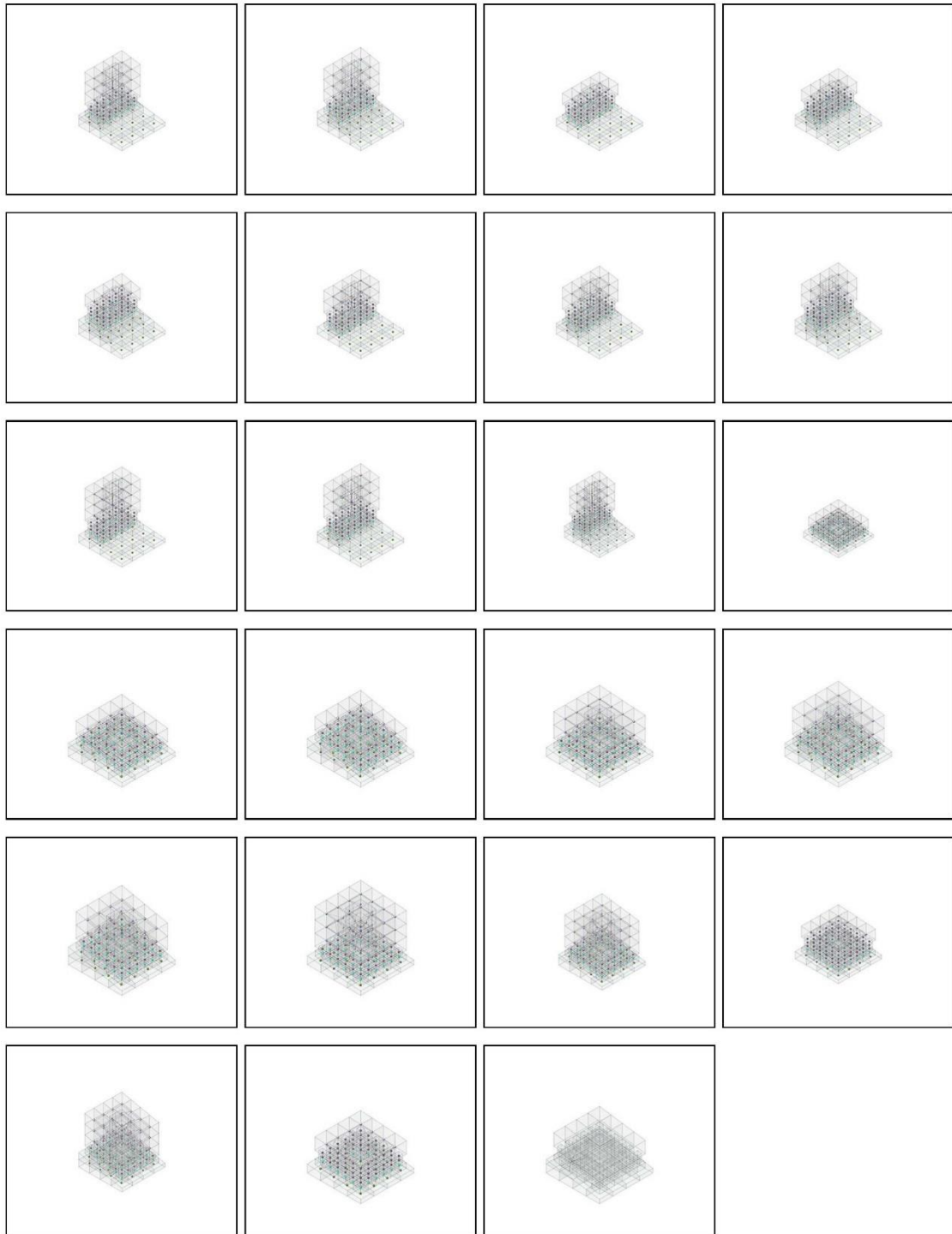

Adherence on Sloped Ground

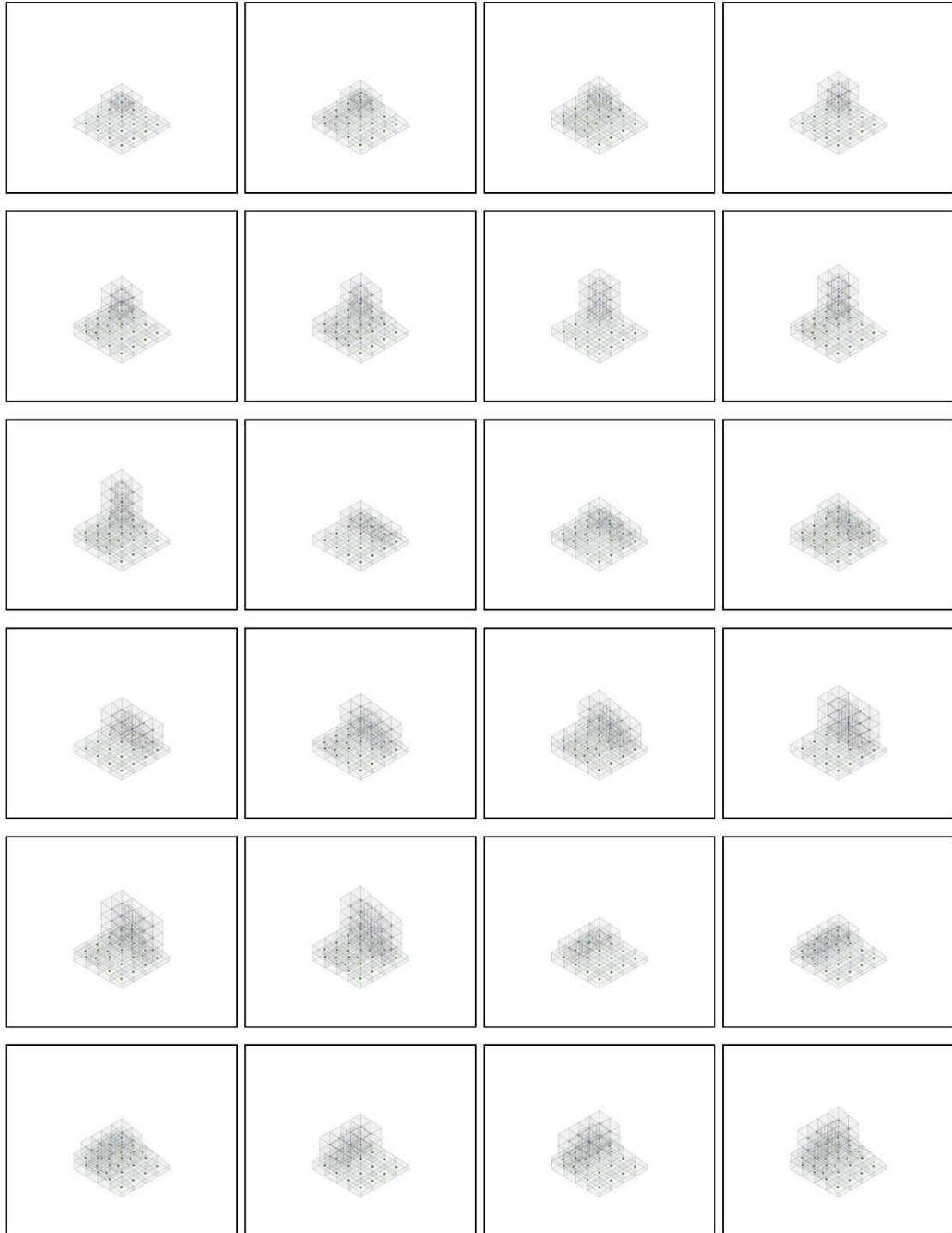

Adherence/ Adherence with Plinth on Sloped Ground

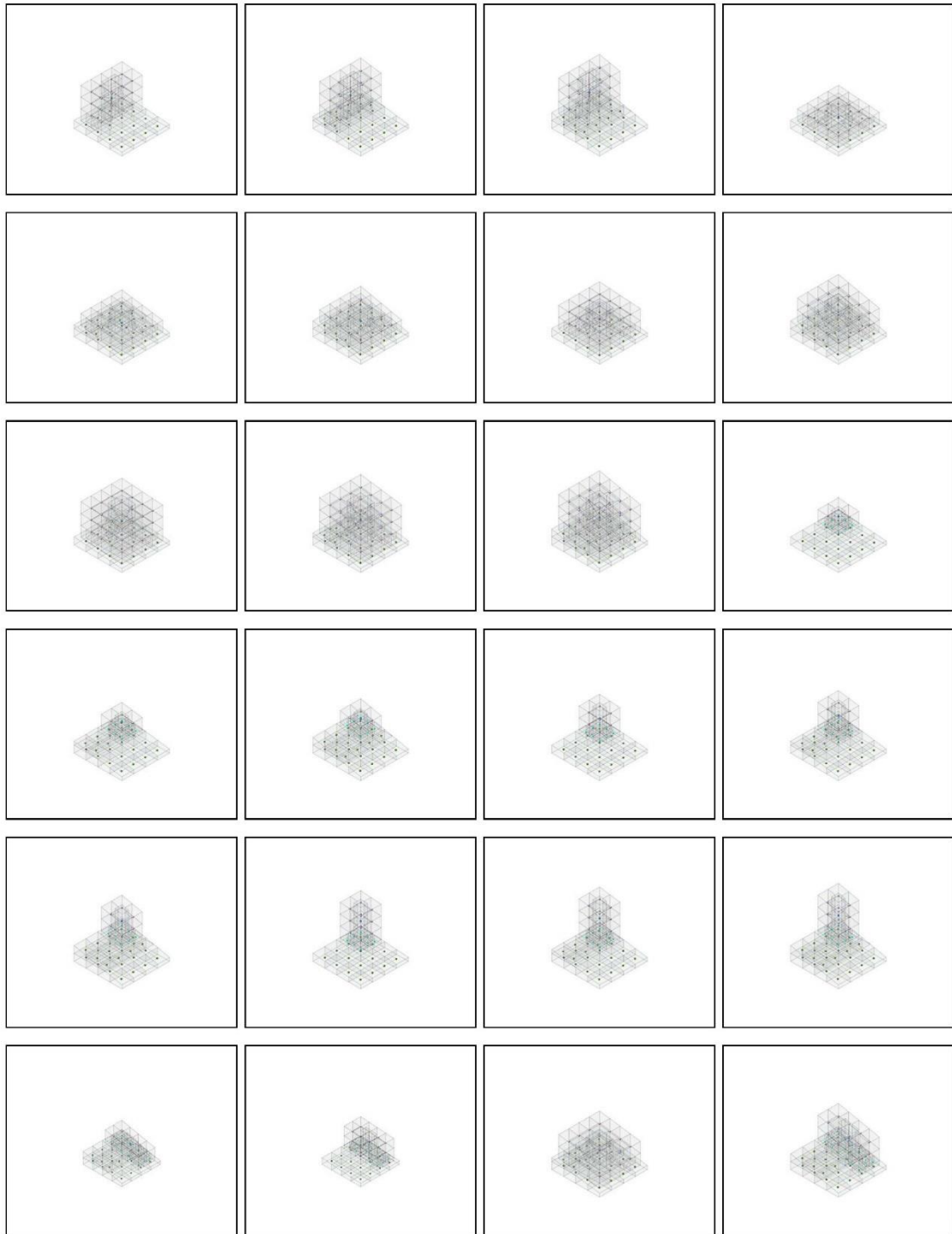

Adherence with Plinth on Sloped Ground

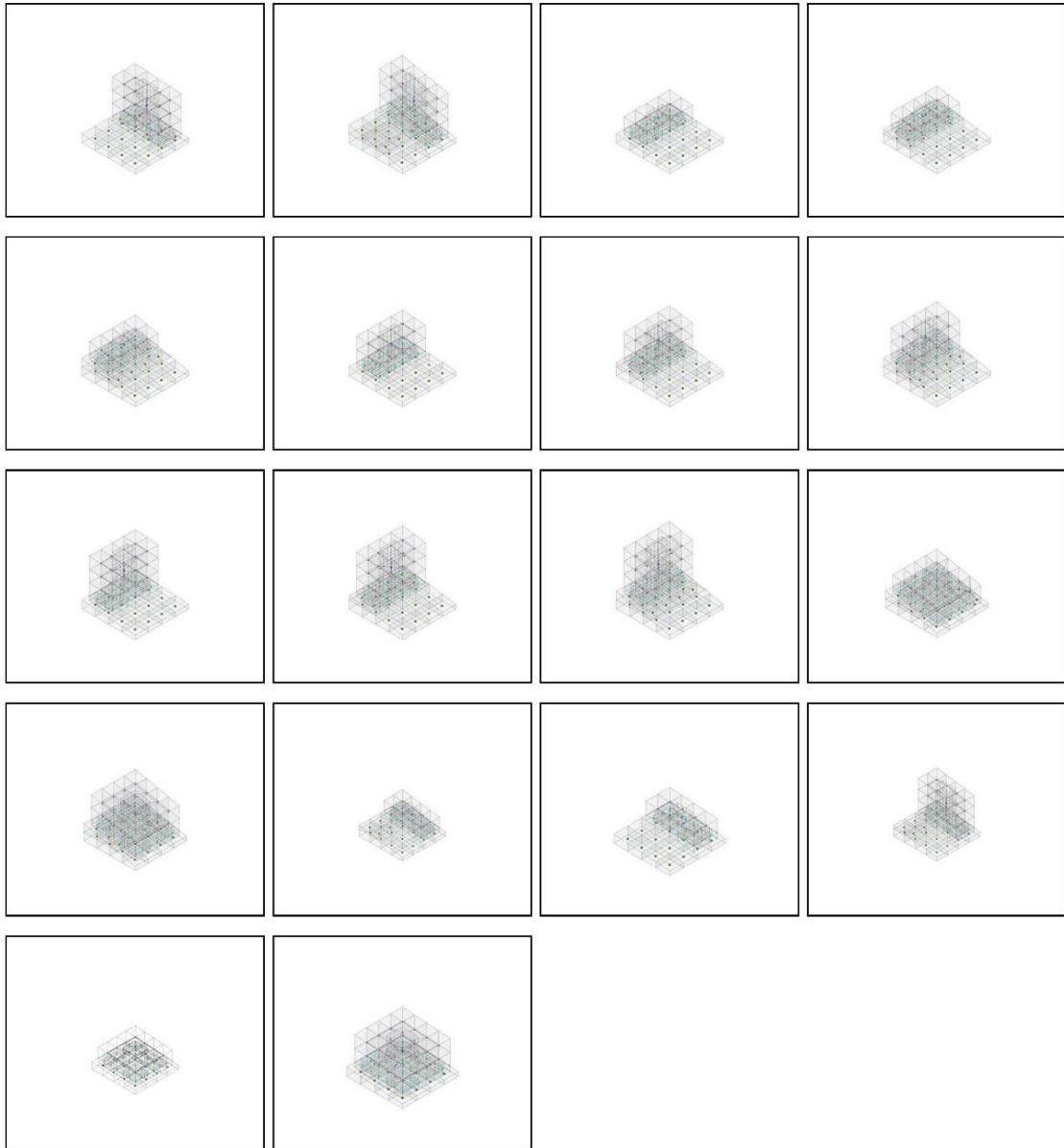

Separation on 1 Level Ground

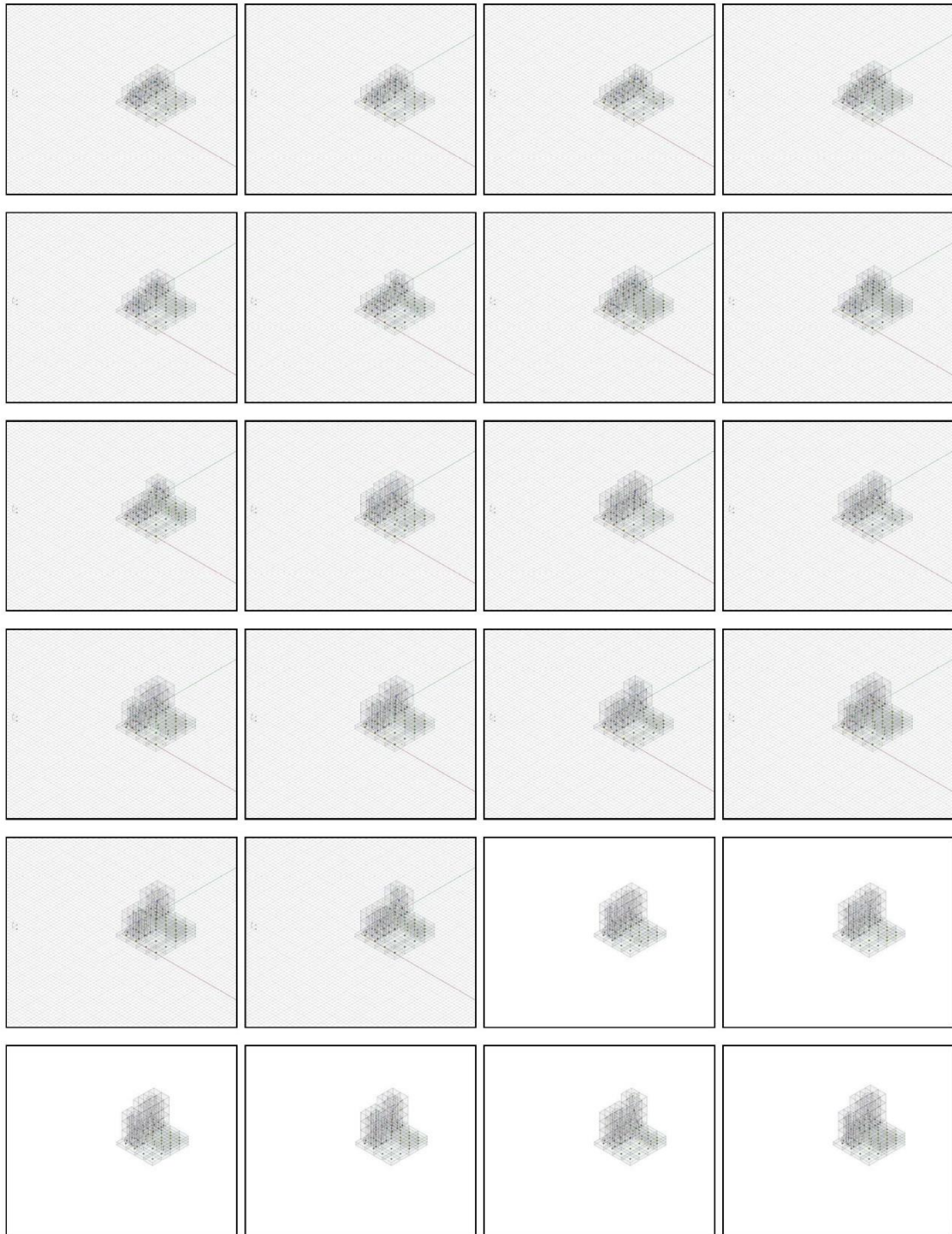

Separation on 1 Level Ground



Separation on 1 Level Ground

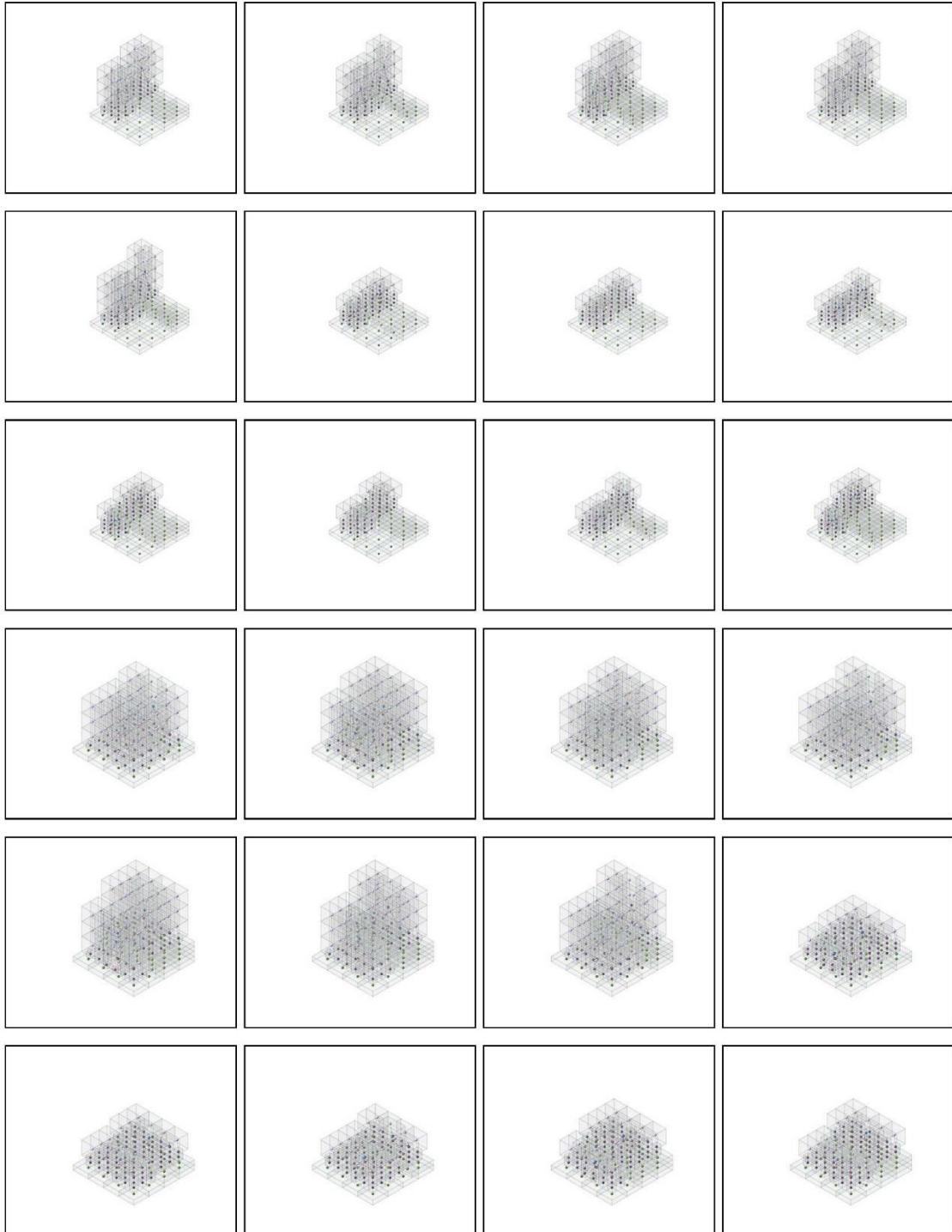

Separation on 1 Level Ground

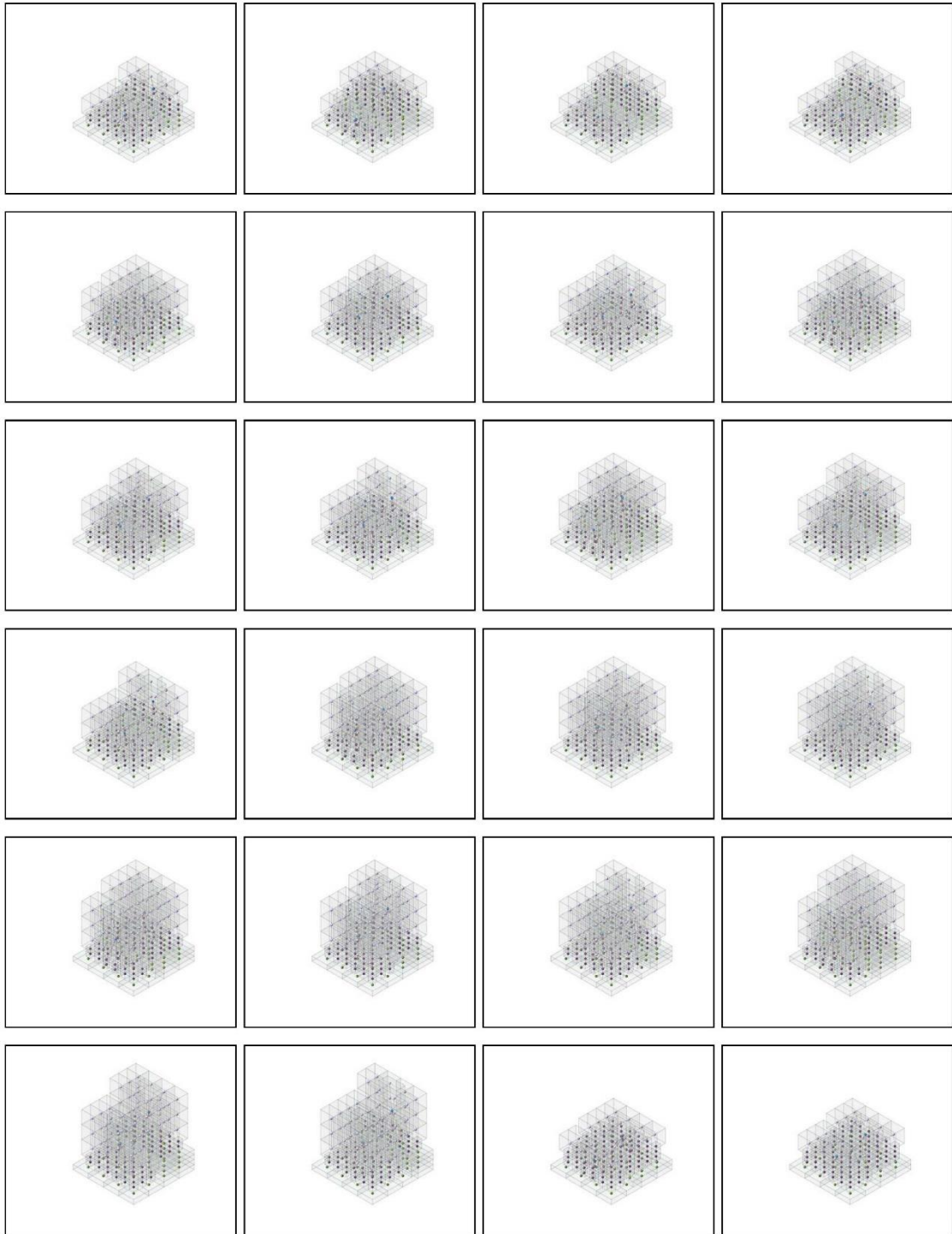

Separation on 1 Level Ground

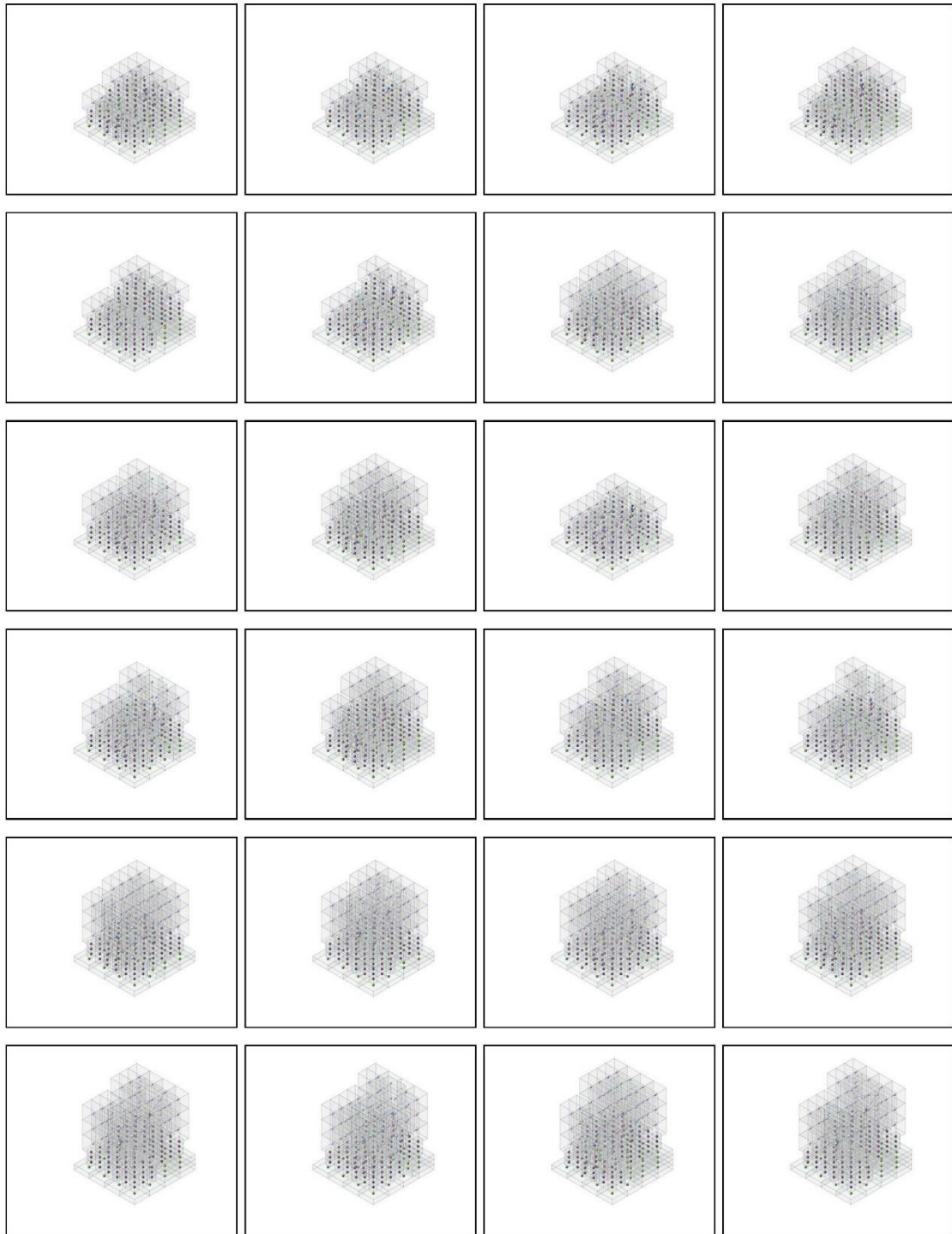

Separation on 1 Level Ground

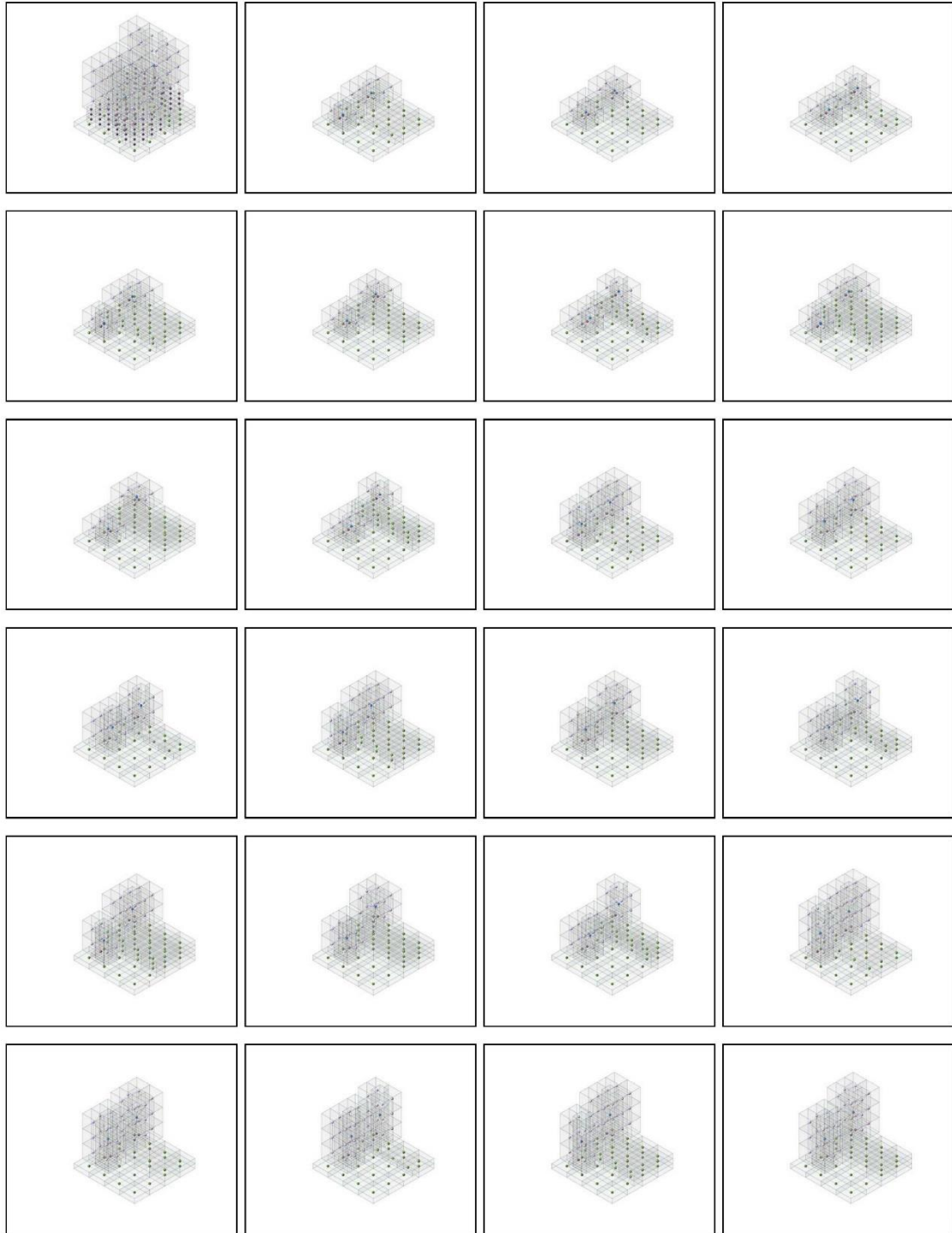

Separation on 1 Level Ground

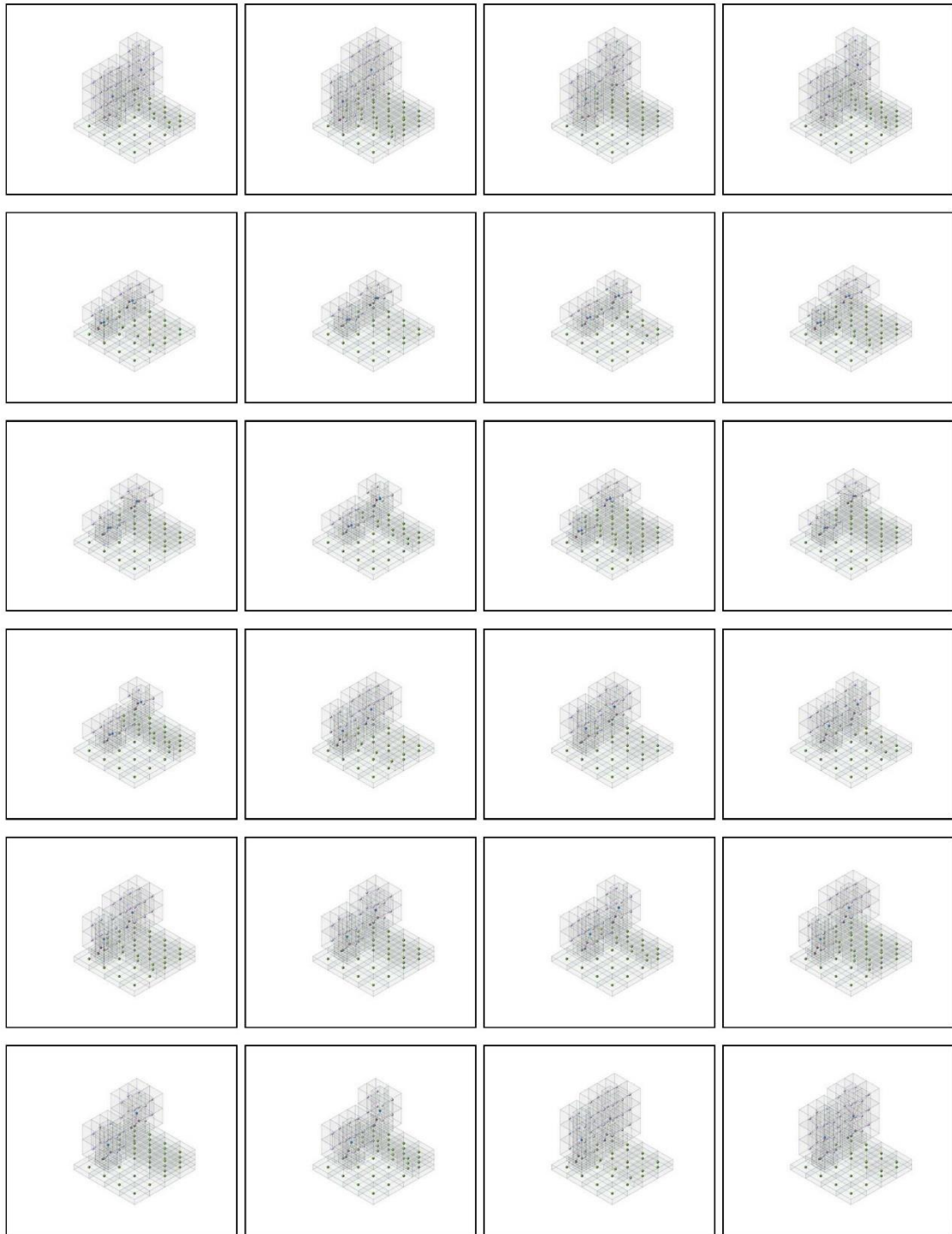

Separation on 1 Level Ground

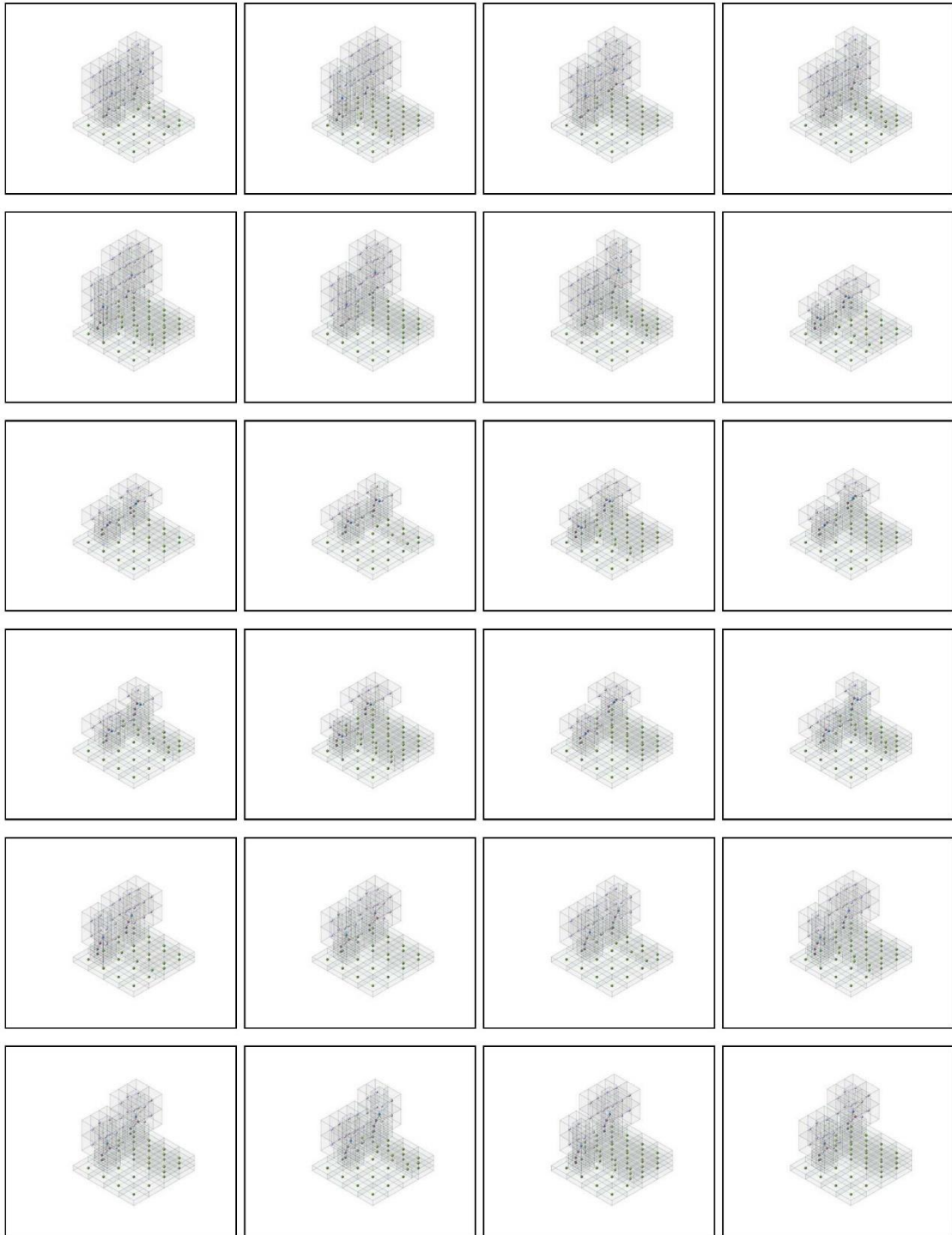

Separation on 1 Level Ground

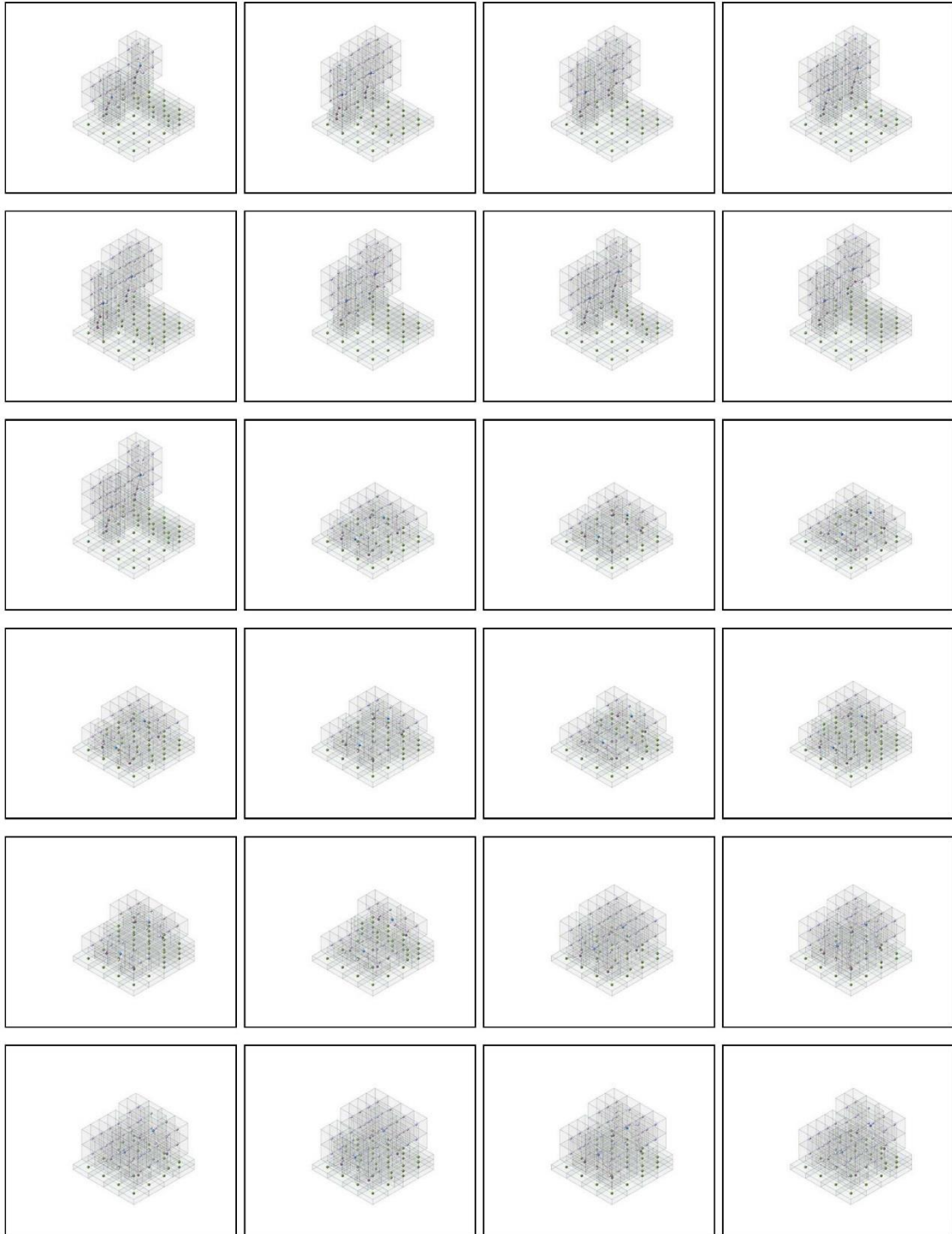

Separation on 1 Level Ground

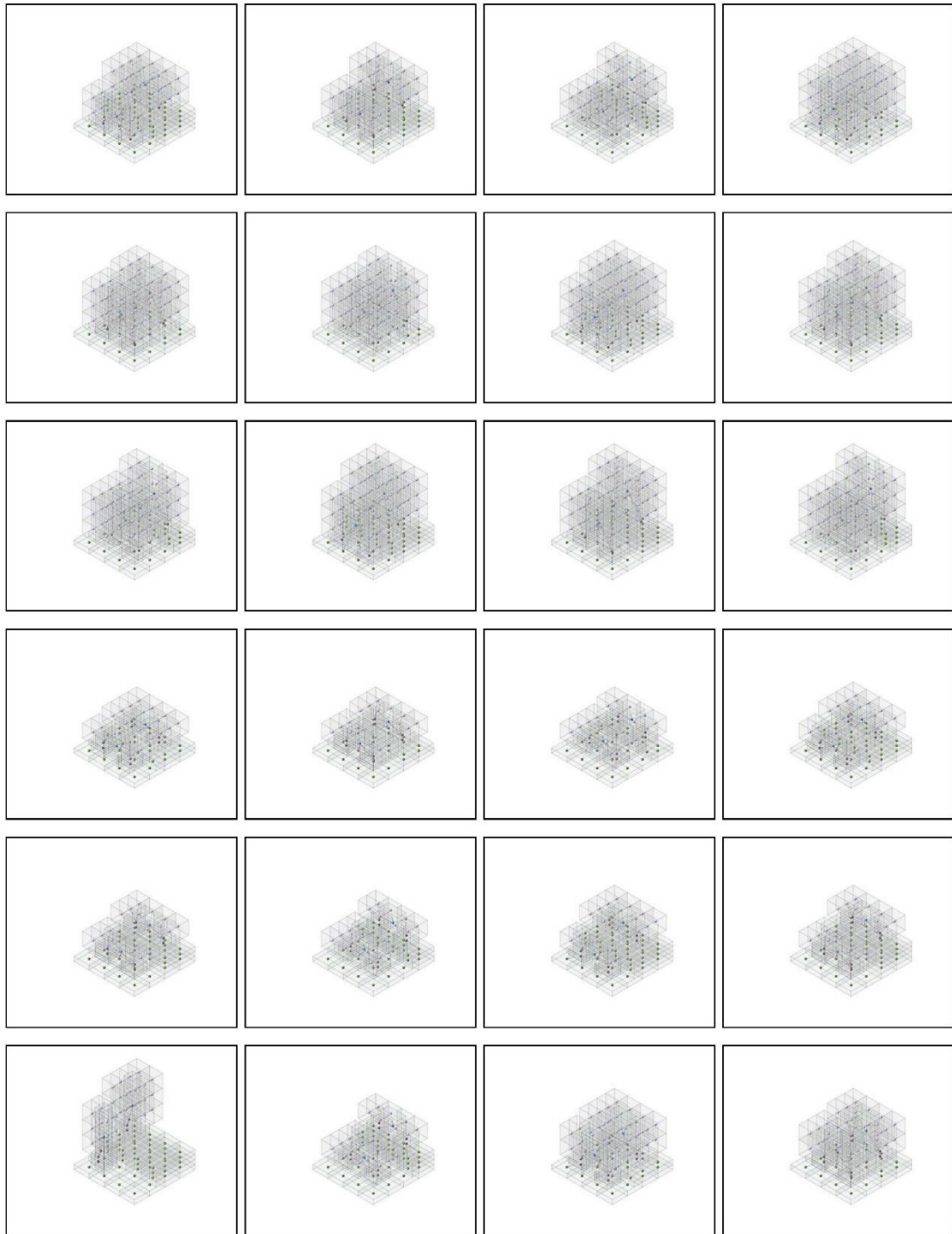

Separation on 1 Level Ground

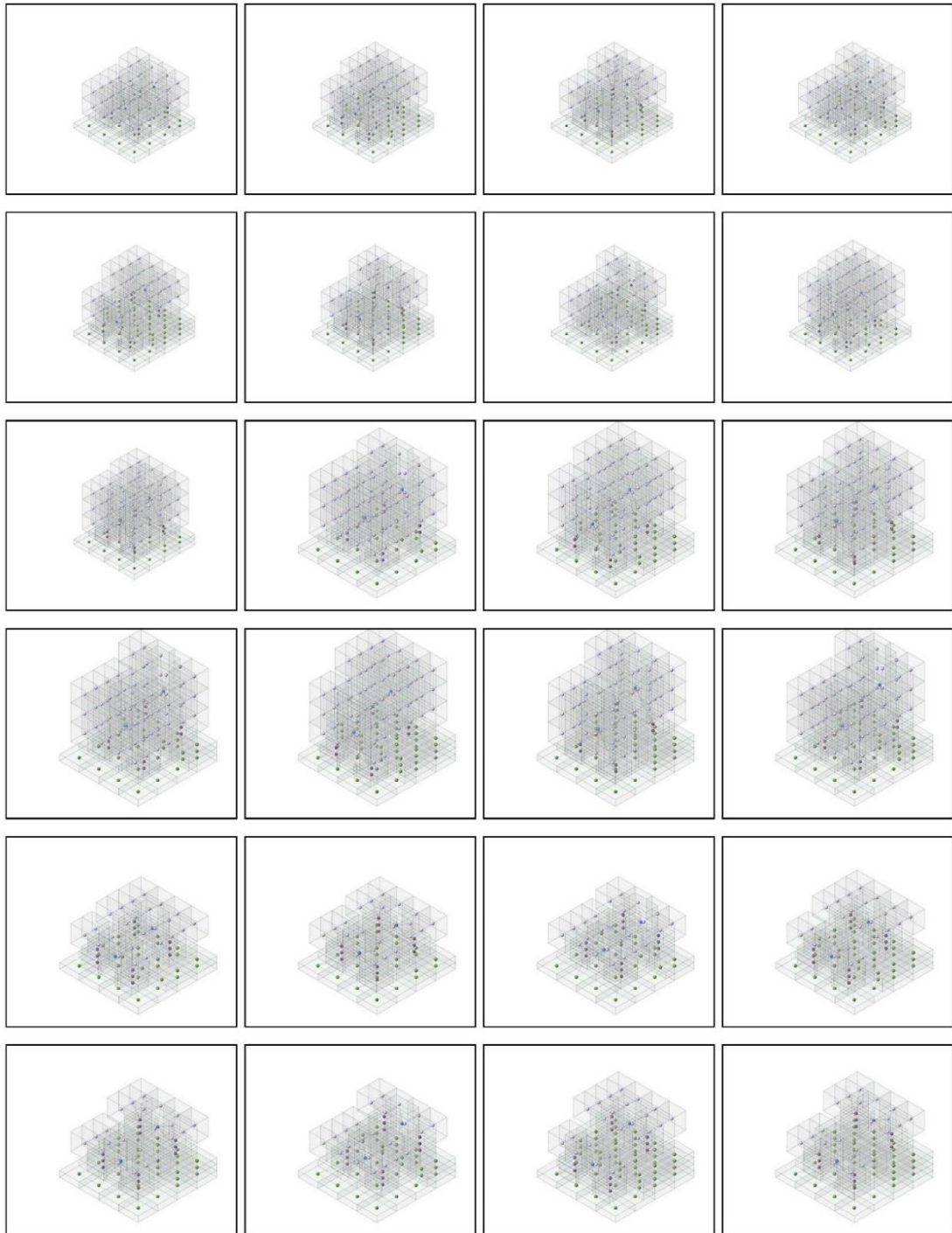

Separation on 1 Level Ground



Separation on 1 Level Ground

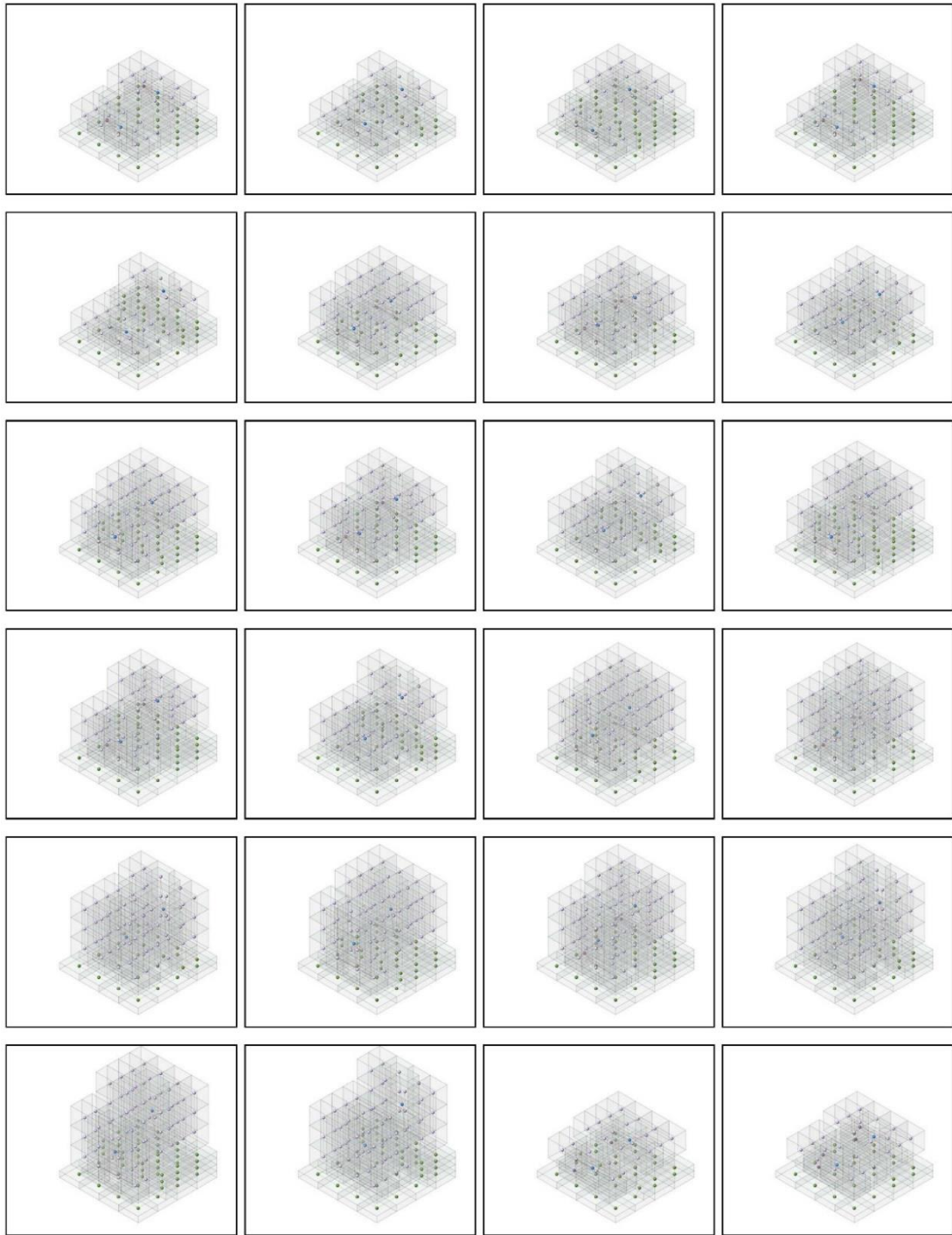

Separation on 1 Level Ground

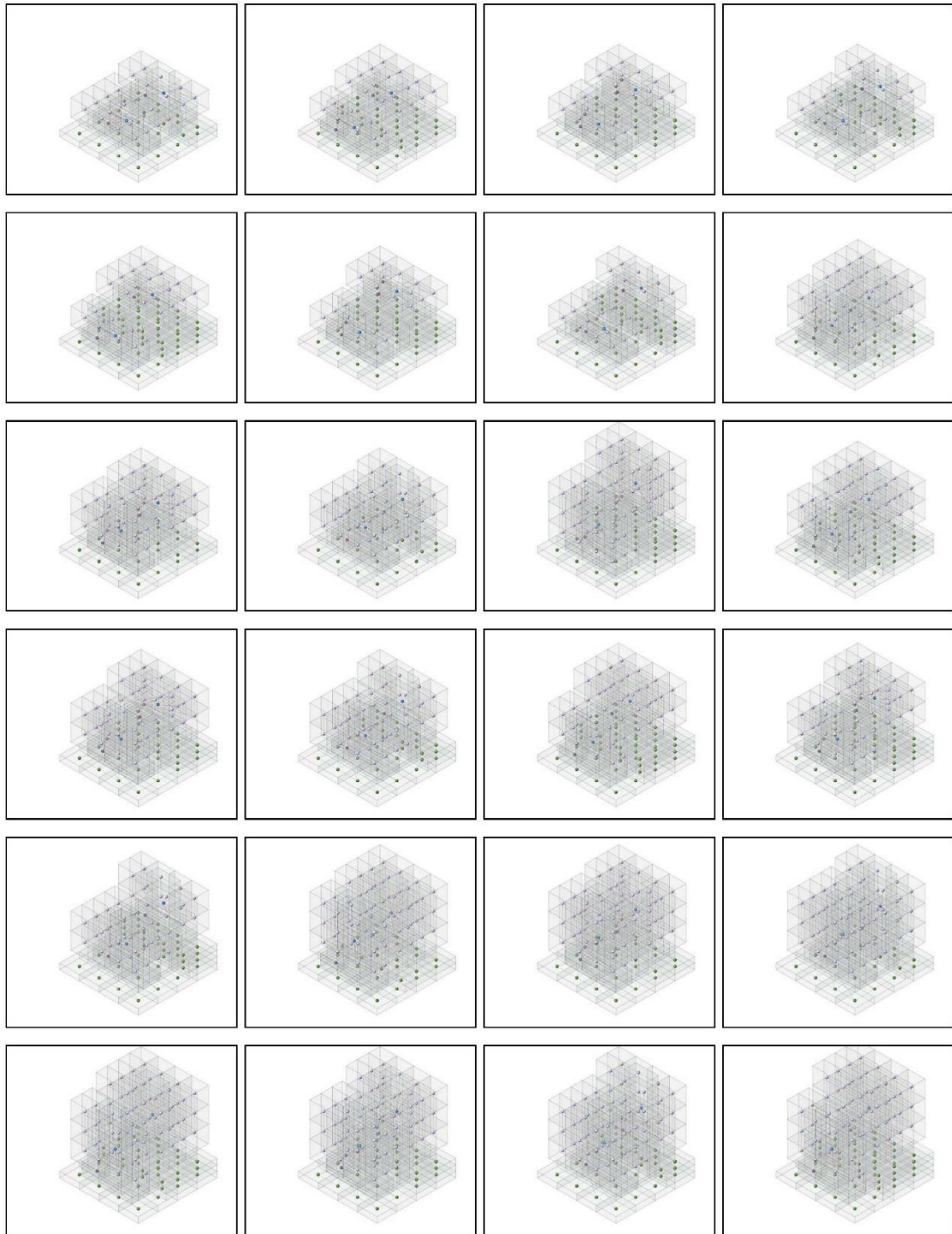

Separation on 1 Level Ground



Separation/ Separation with Plinth on 1 Level Ground



Separation with Plinth on 1 Level Ground



Separation with Plinth on 1 Level Ground



Separation with Plinth on 1 Level Ground



Separation with Plinth on 1 Level Ground



Separation with Plinth on 1 Level Ground



Separation with Plinth on 1 Level Ground



Separation with Plinth on 1 Level Ground

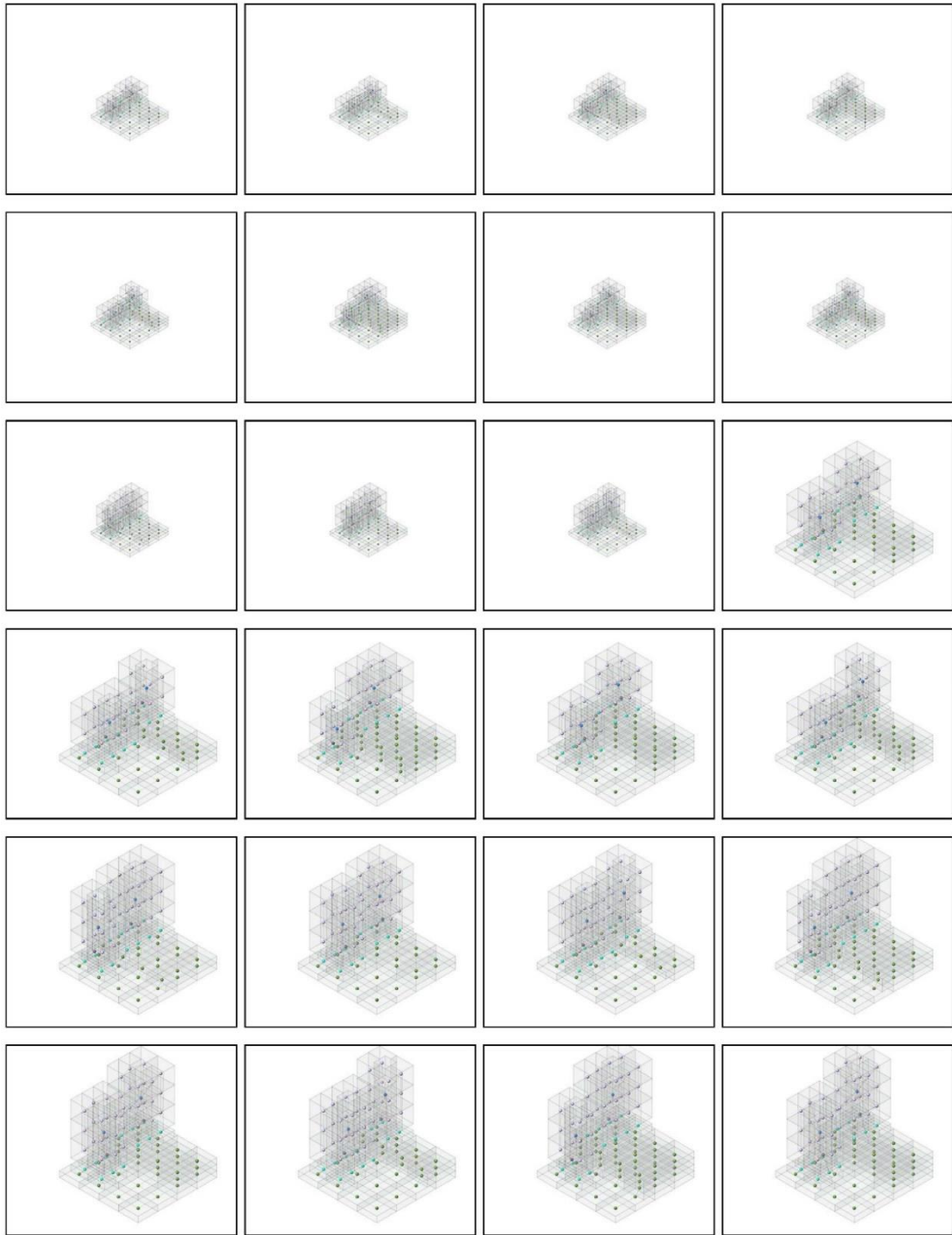

Separation with Plinth on 1 Level Ground

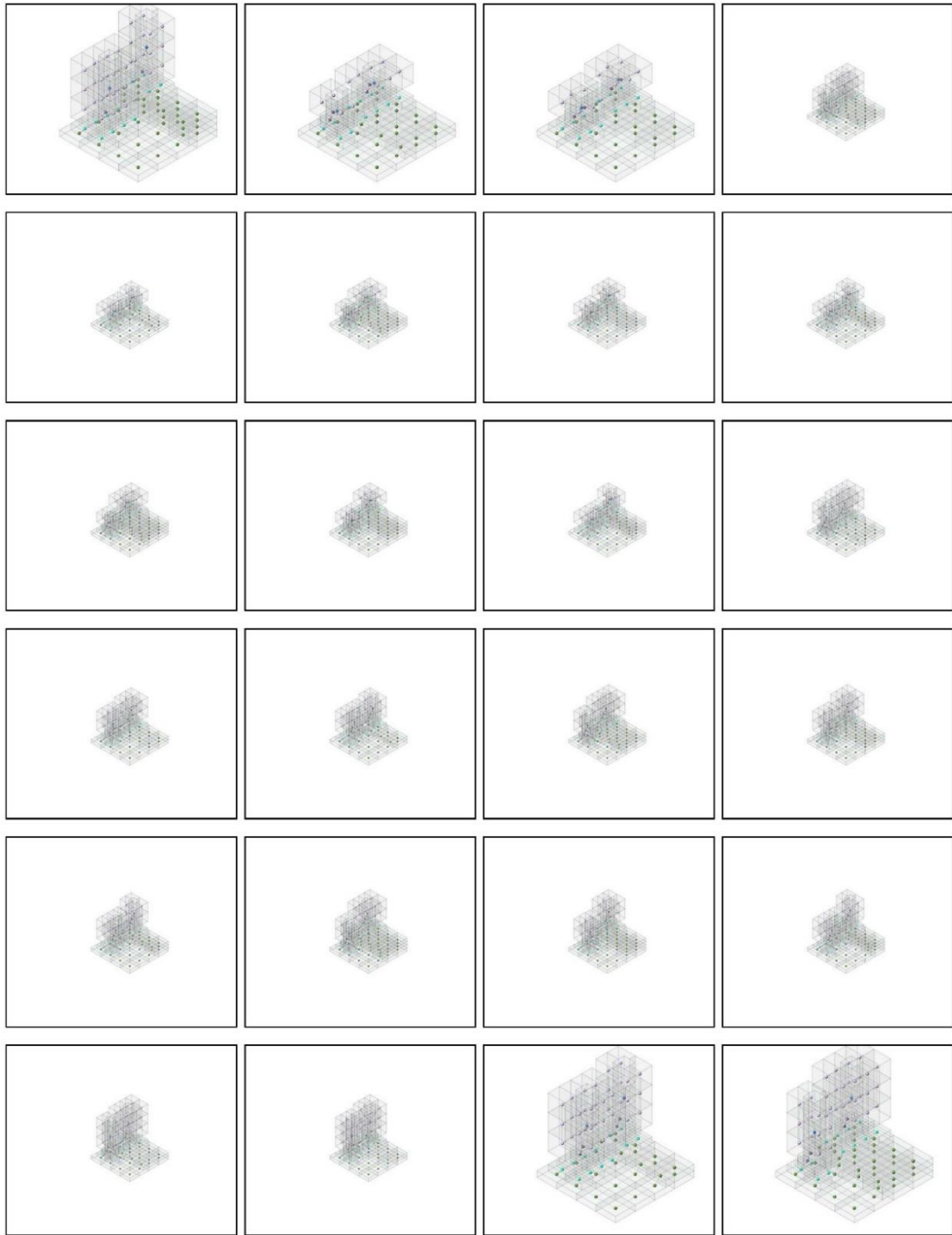

Separation with Plinth on 1 Level Ground

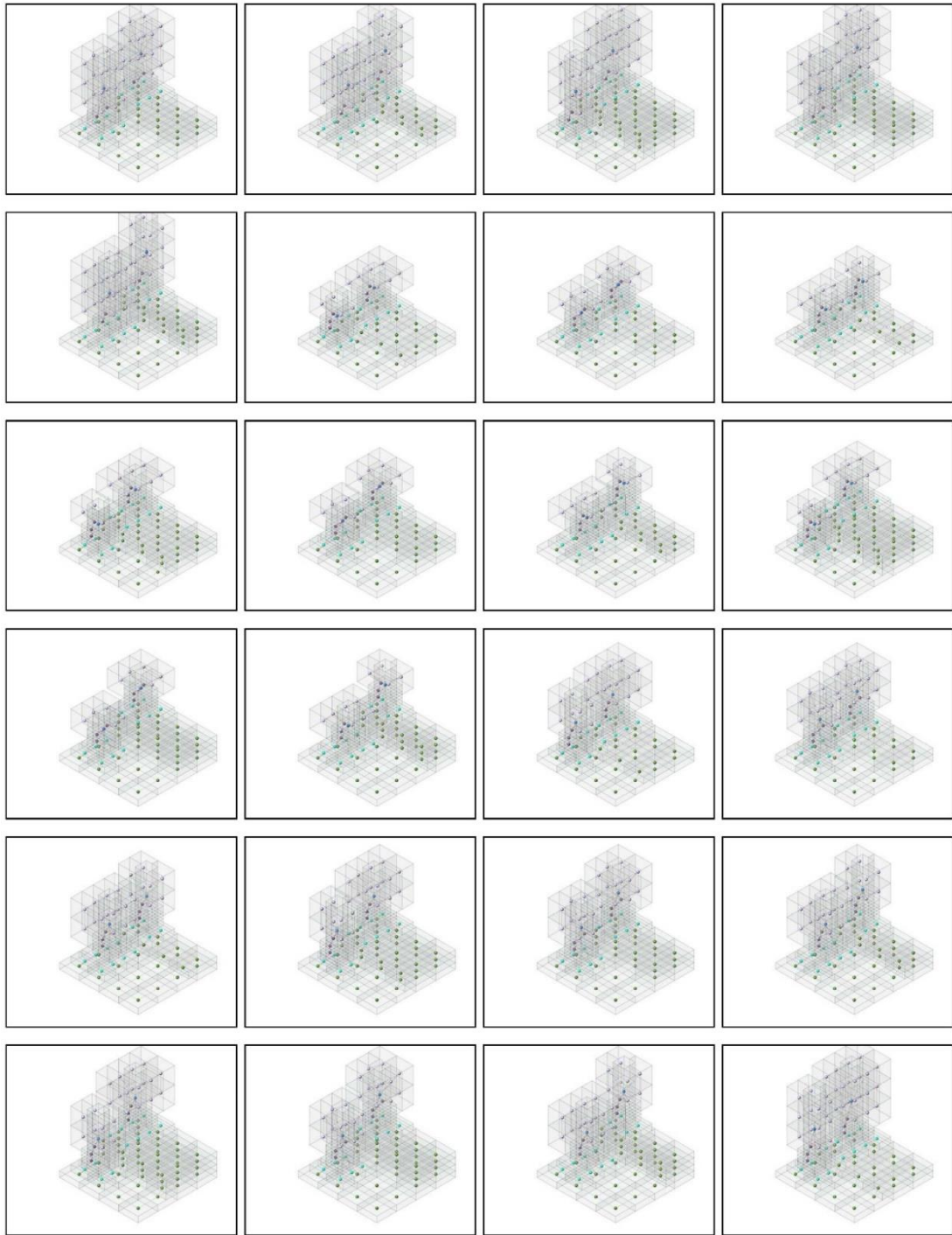

Separation with Plinth on 1 Level Ground



Separation with Plinth on 1 Level Ground



Separation with Plinth on 1 Level Ground

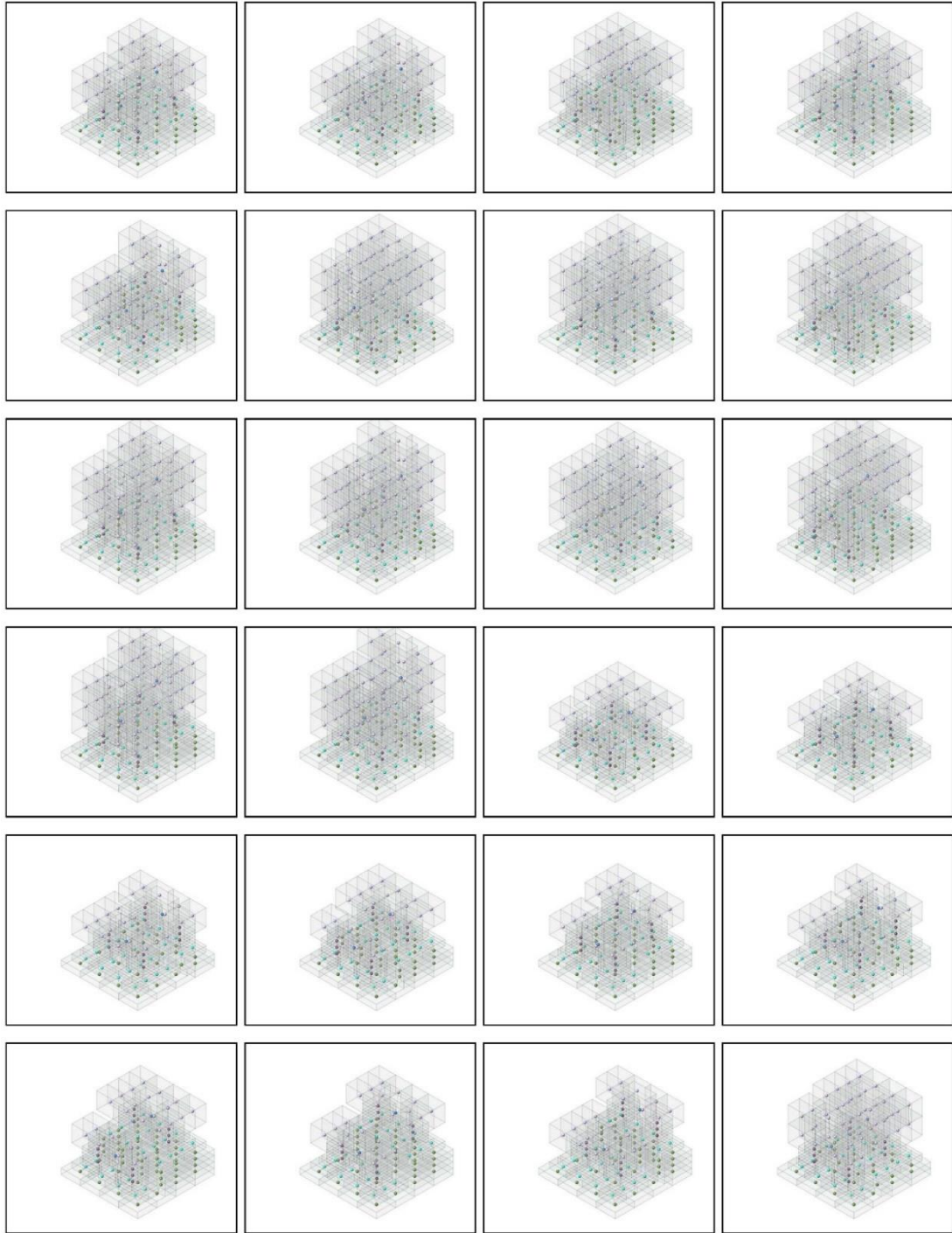

Separation with Plinth on 1 Level Ground

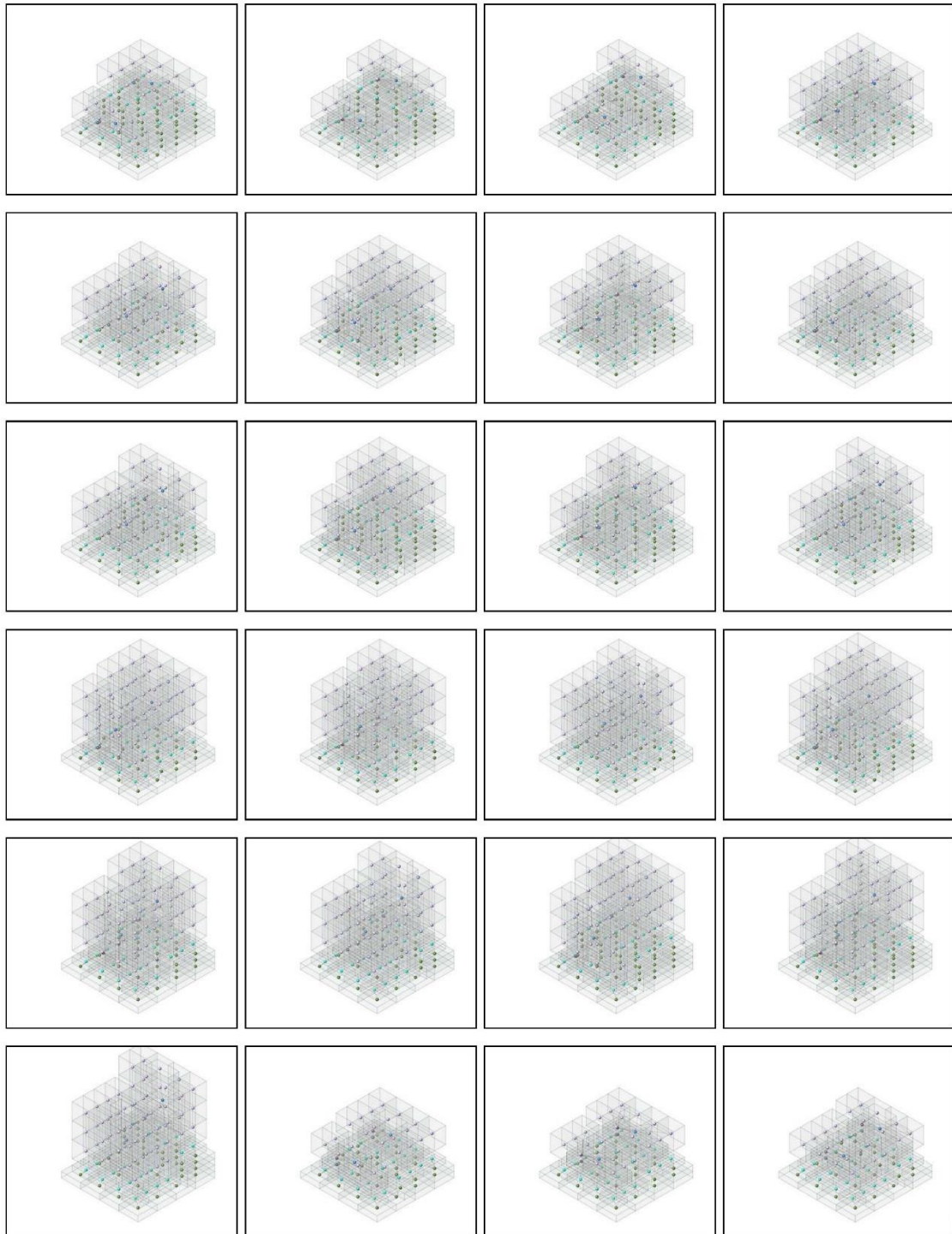

Separation with Plinth on 1 Level Ground



Separation with Plinth on 1 Level Ground



Adherence on 1 Level Ground

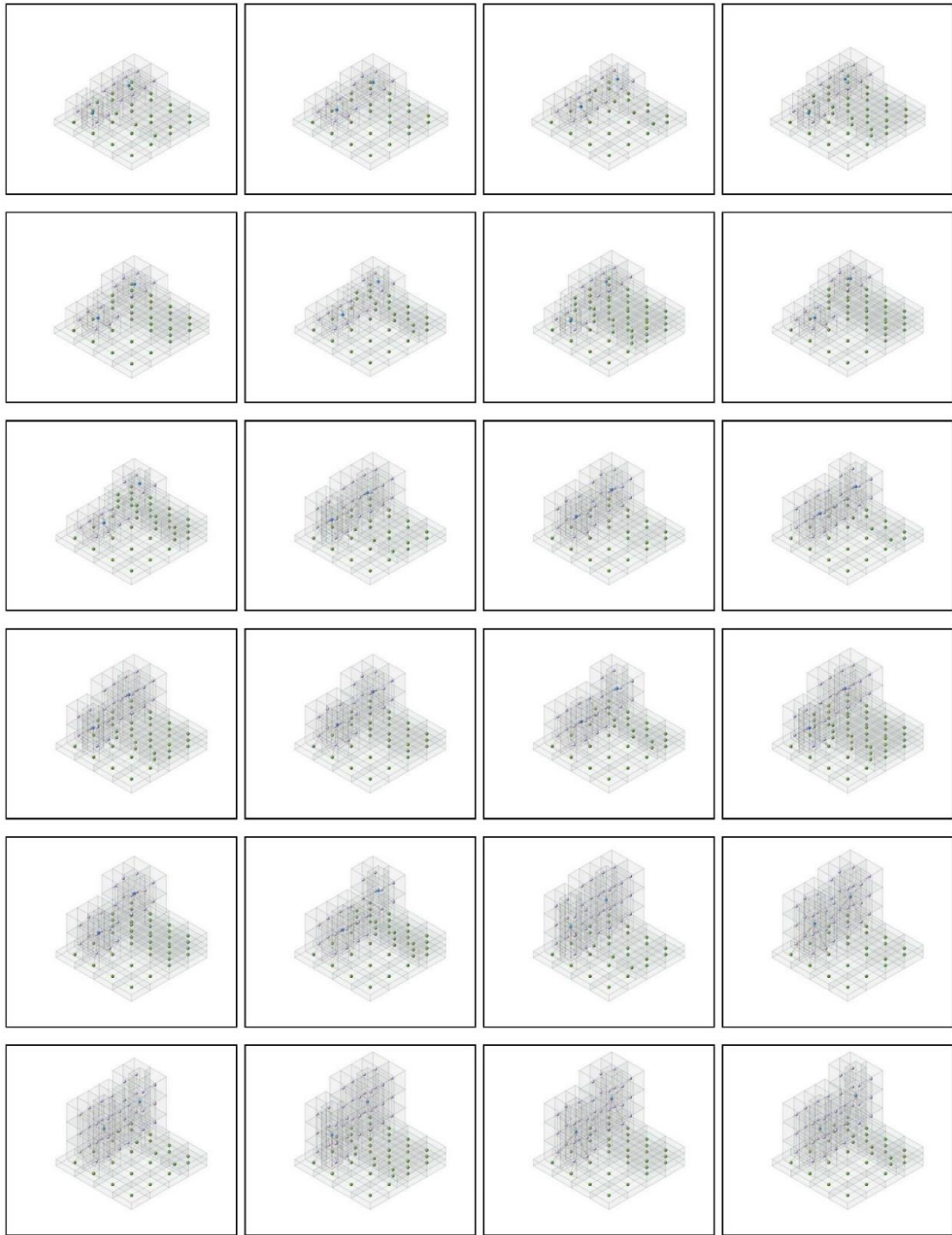

Adherence on 1 Level Ground

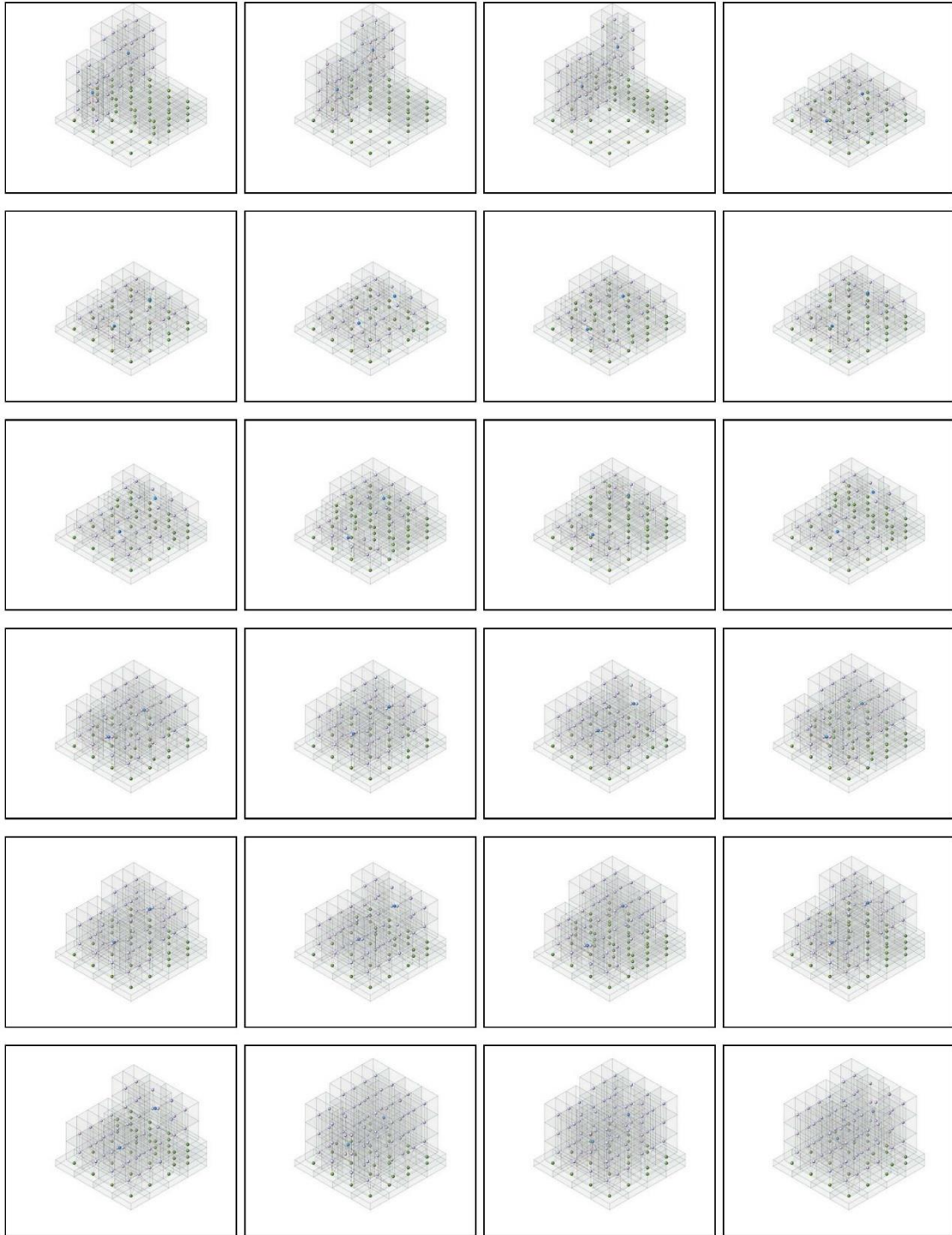

Adherence/ Adherence with Plinth on 1 Level Ground



Adherence with Plinth on 1 Level Ground



Adherence with Plinth on 1 Level Ground

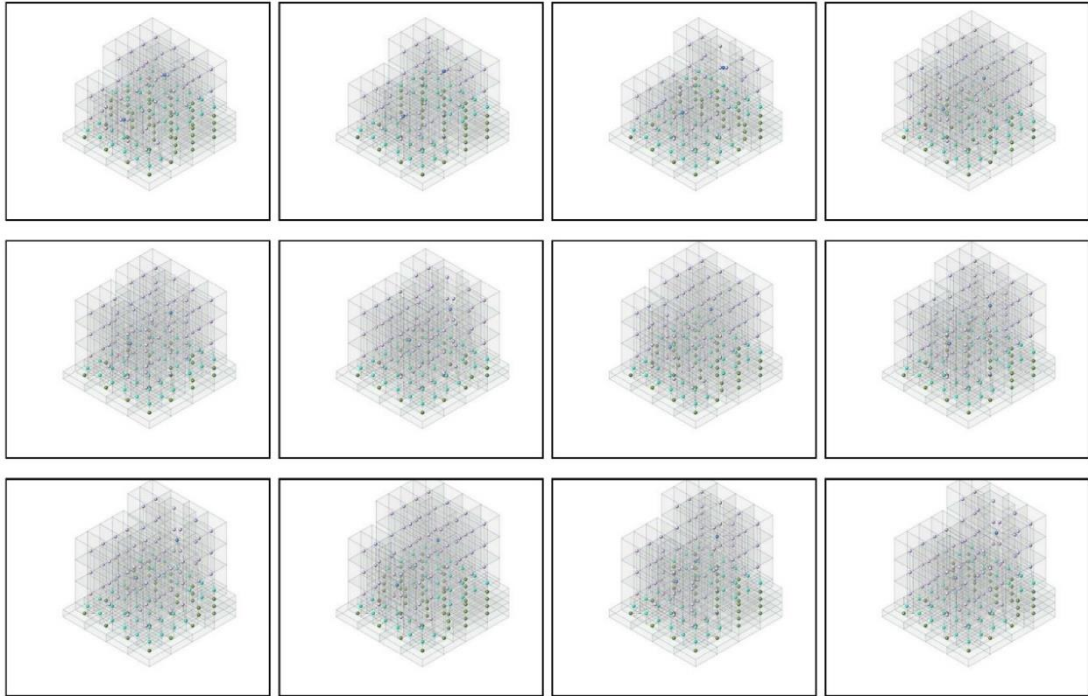

Interlock on 1 Level Ground

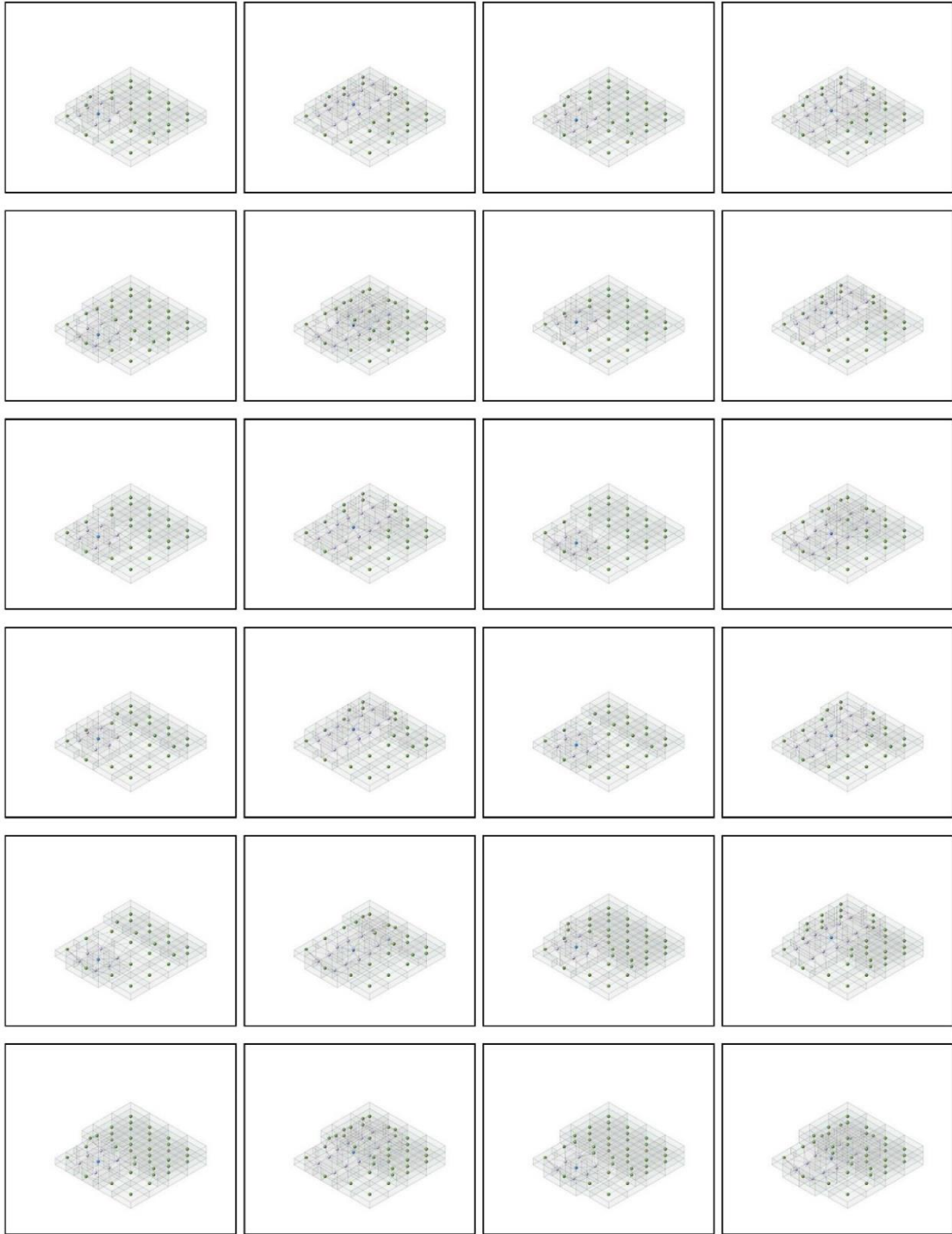

Interlock on 1 Level Ground

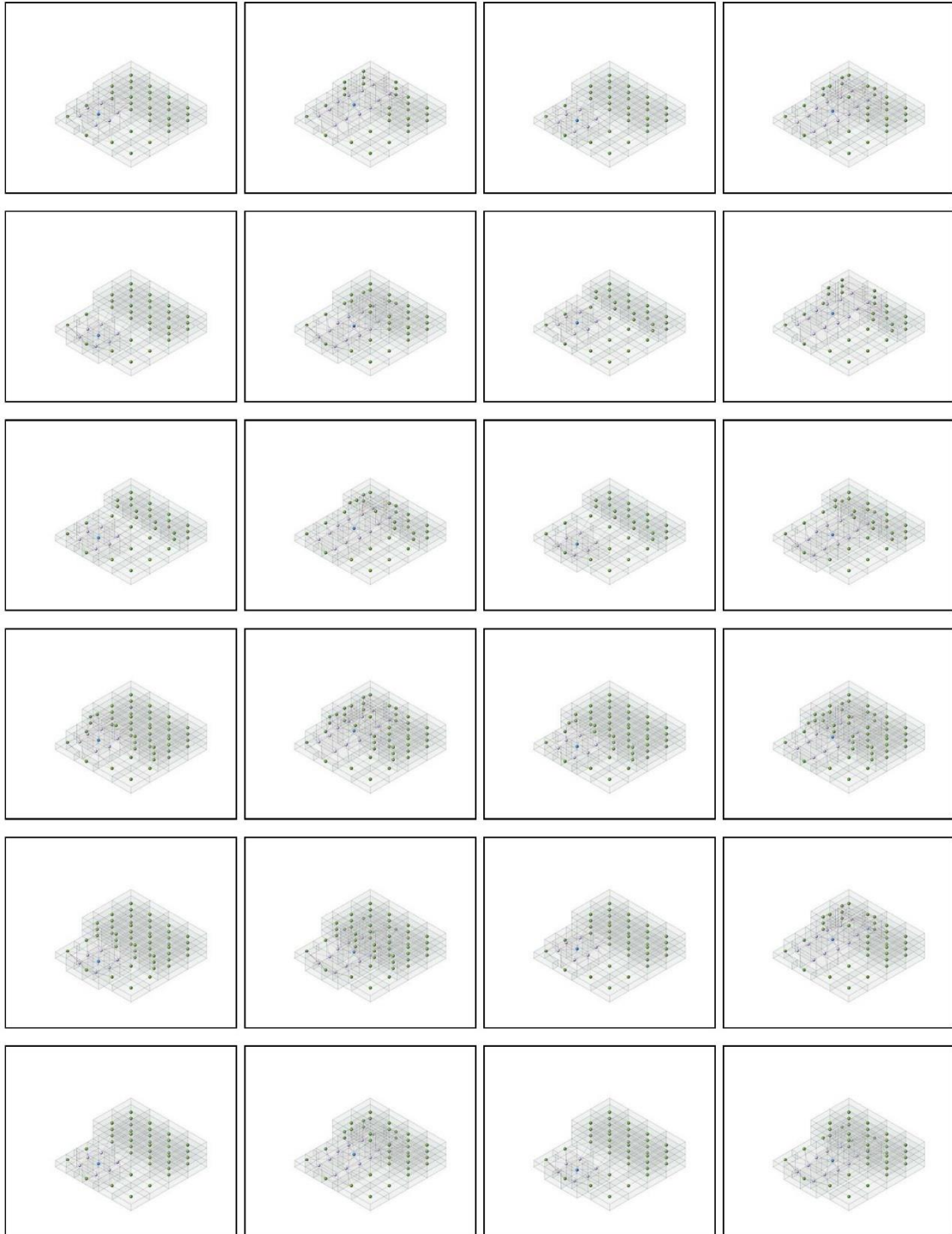

Interlock on 1 Level Ground

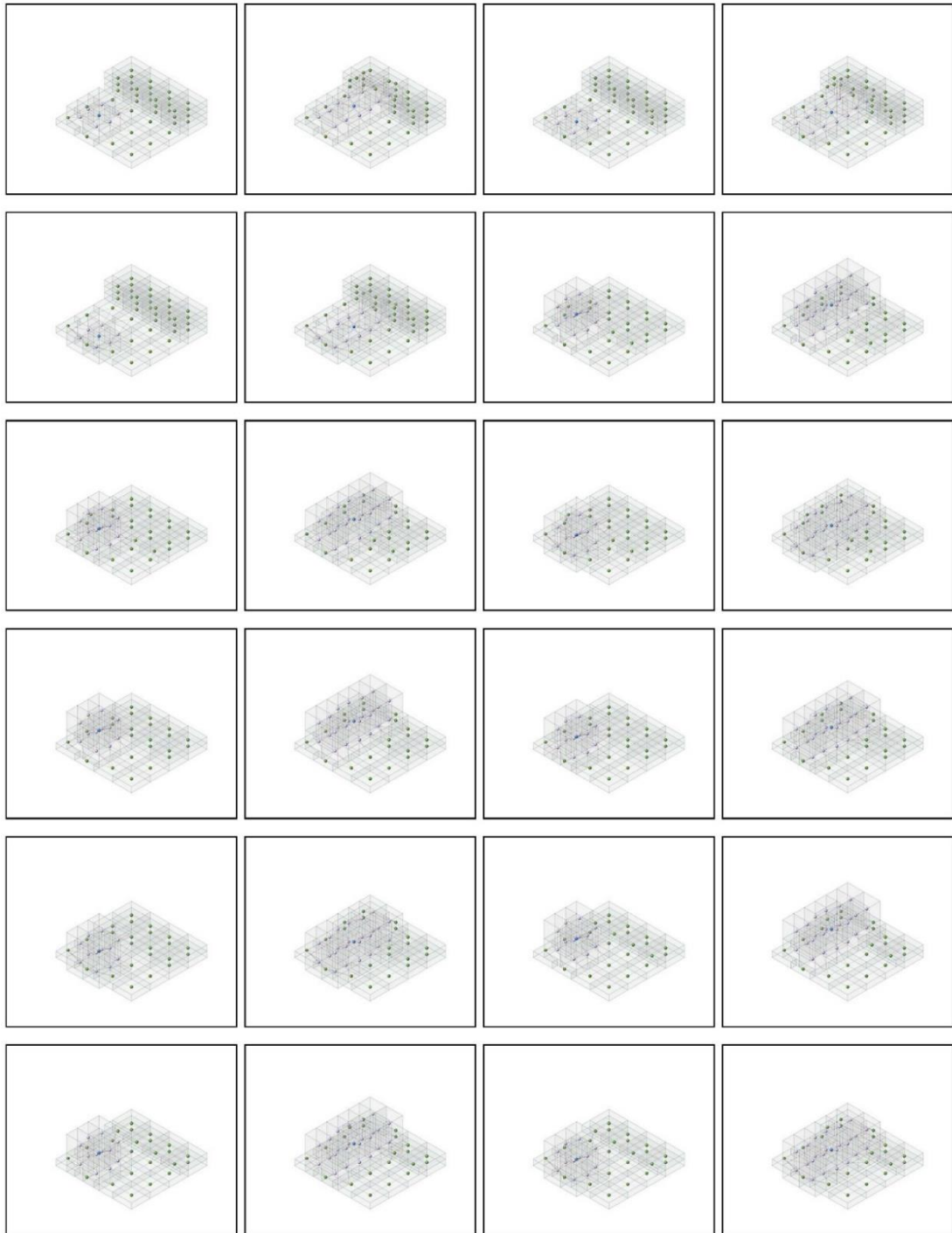

Interlock on 1 Level Ground

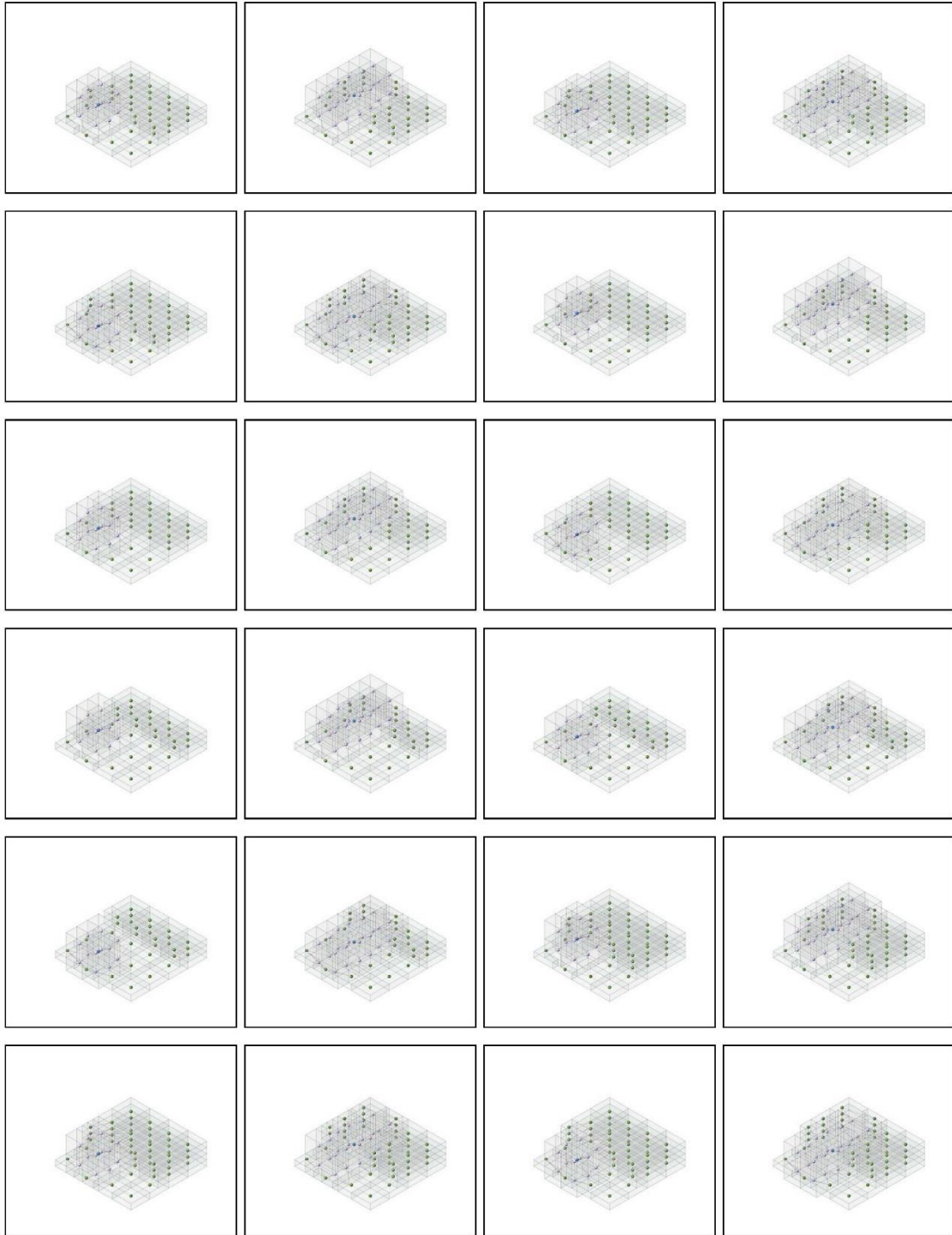

Interlock on 1 Level Ground



Interlock on 1 Level Ground



Interlock on 1 Level Ground

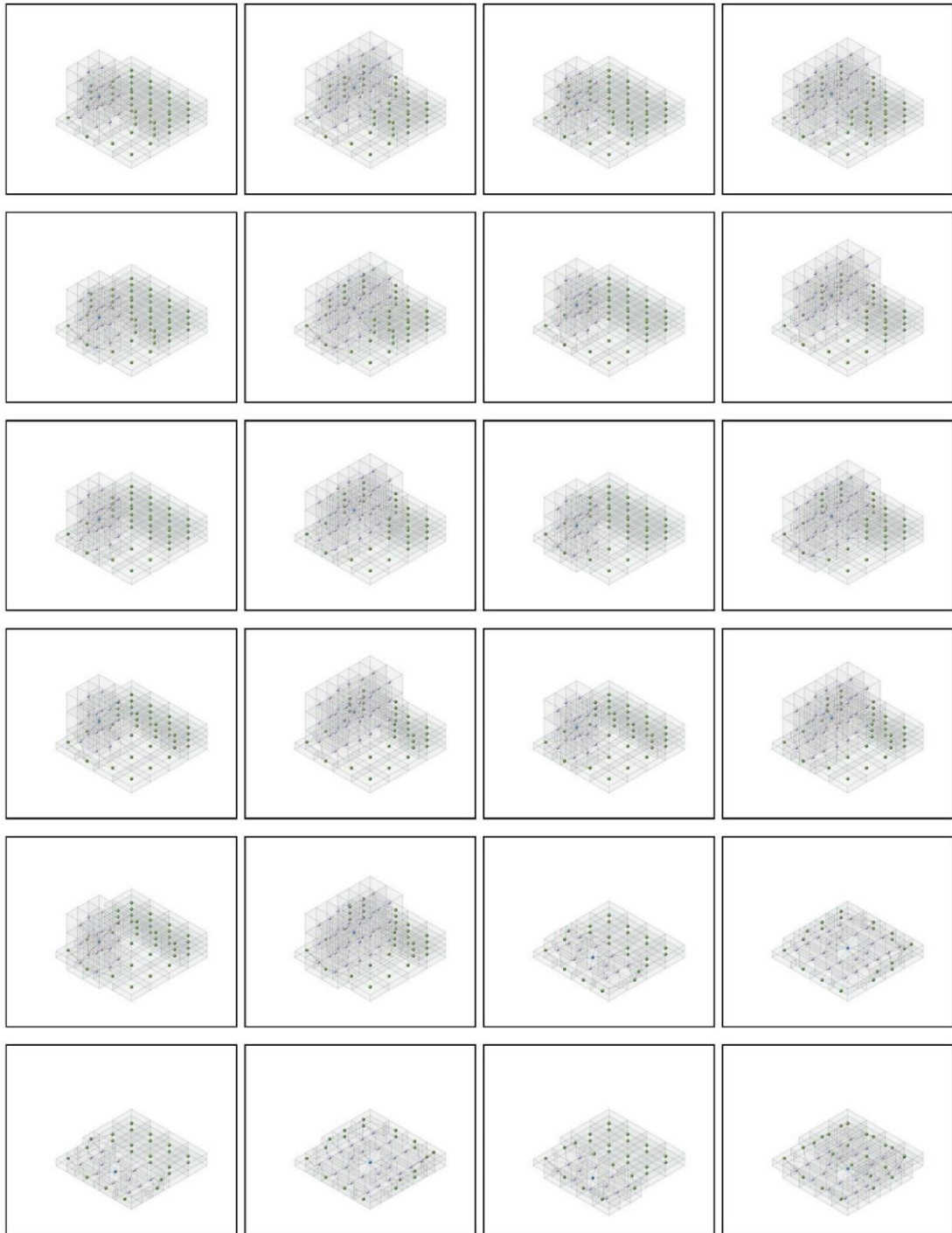

Interlock on 1 Level Ground

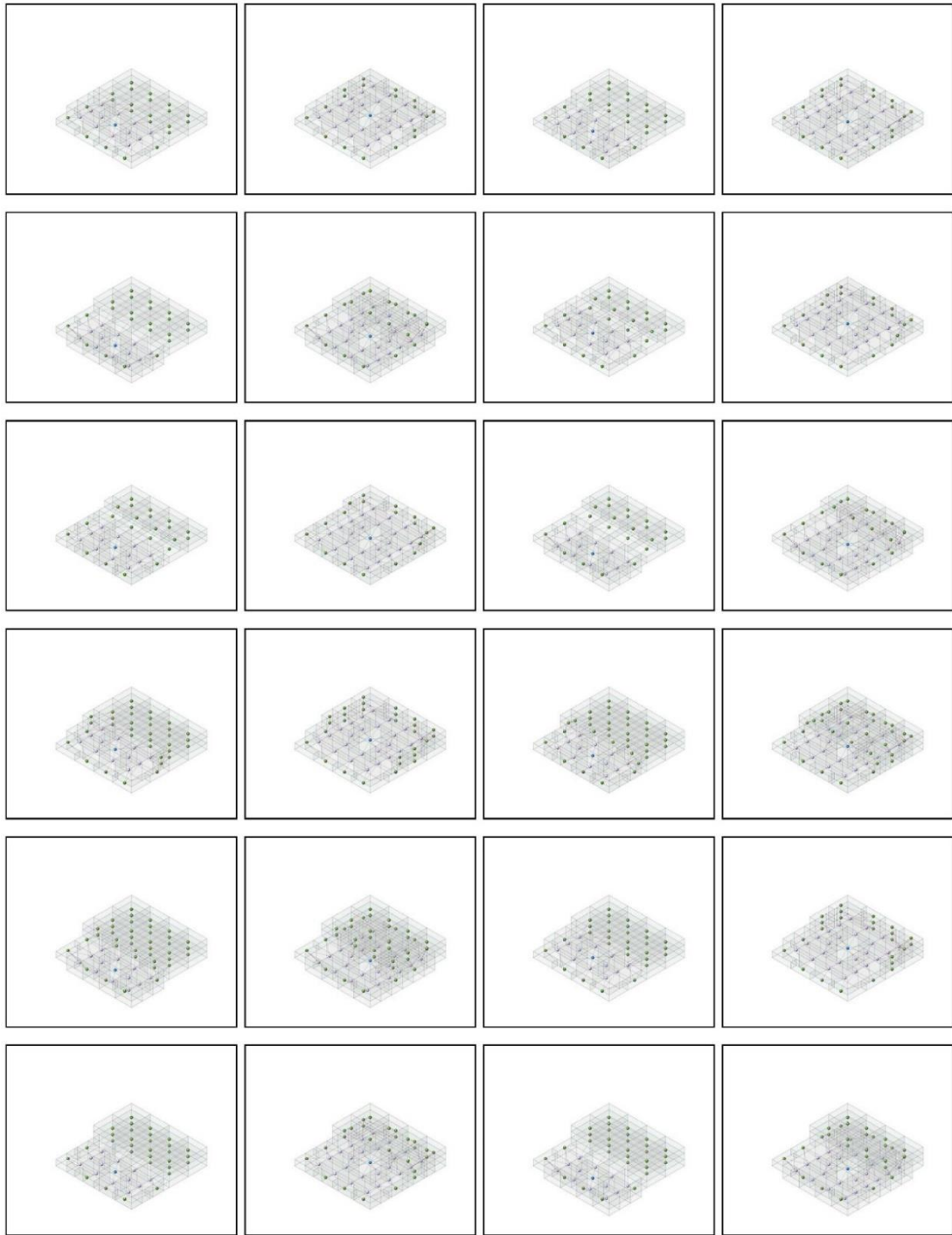

Interlock on 1 Level Ground

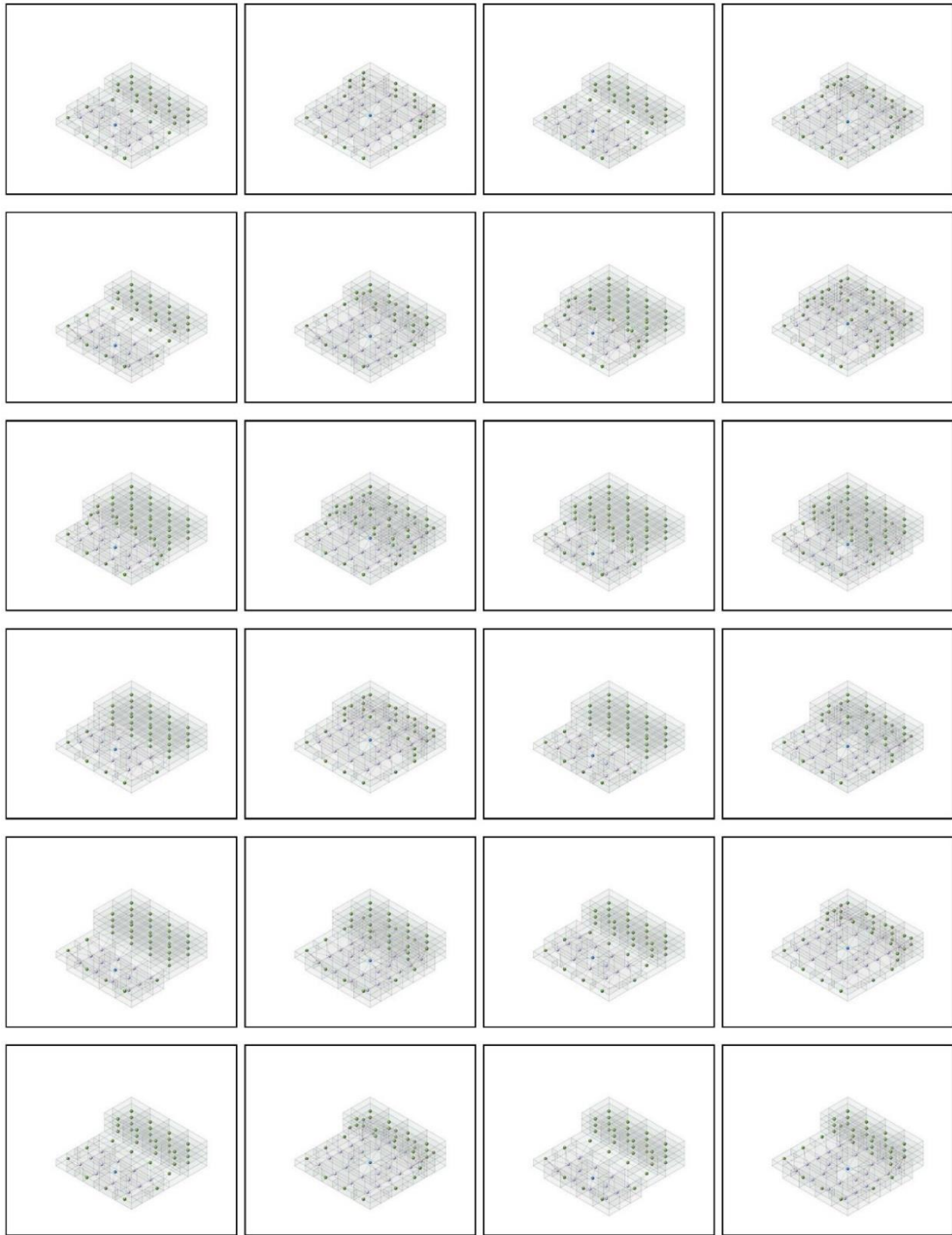

Interlock on 1 Level Ground

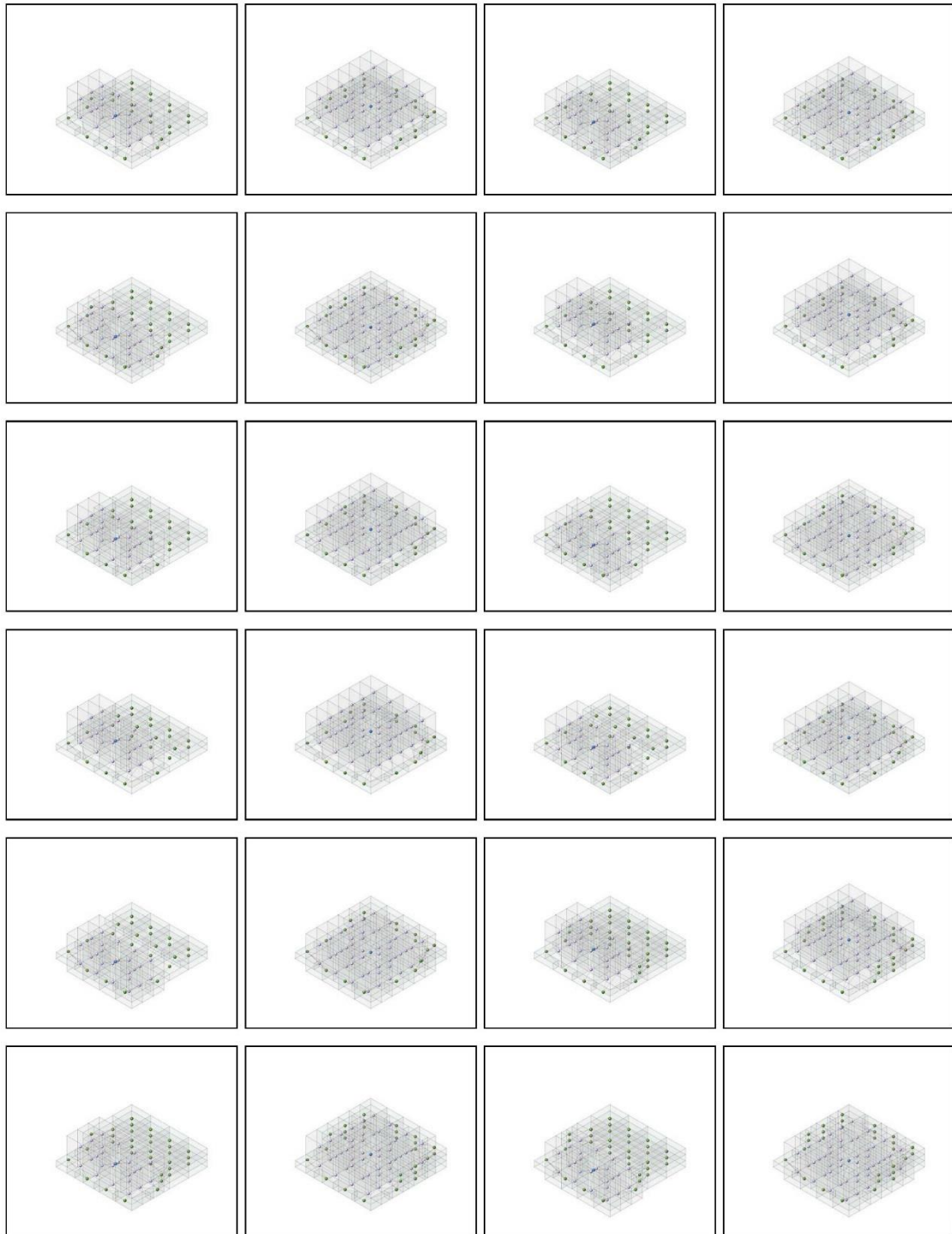

Interlock on 1 Level Ground

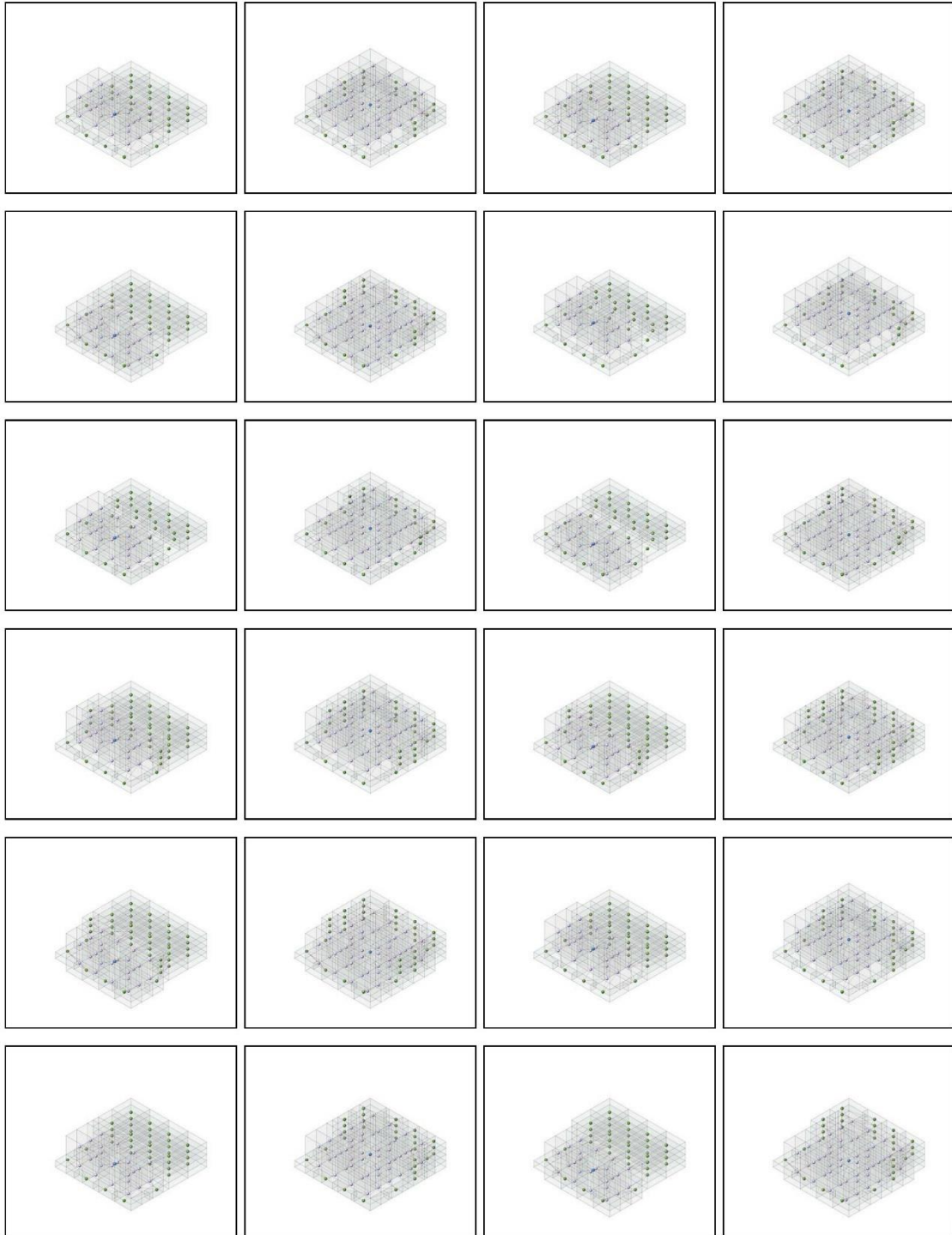

Interlock on 1 Level Ground

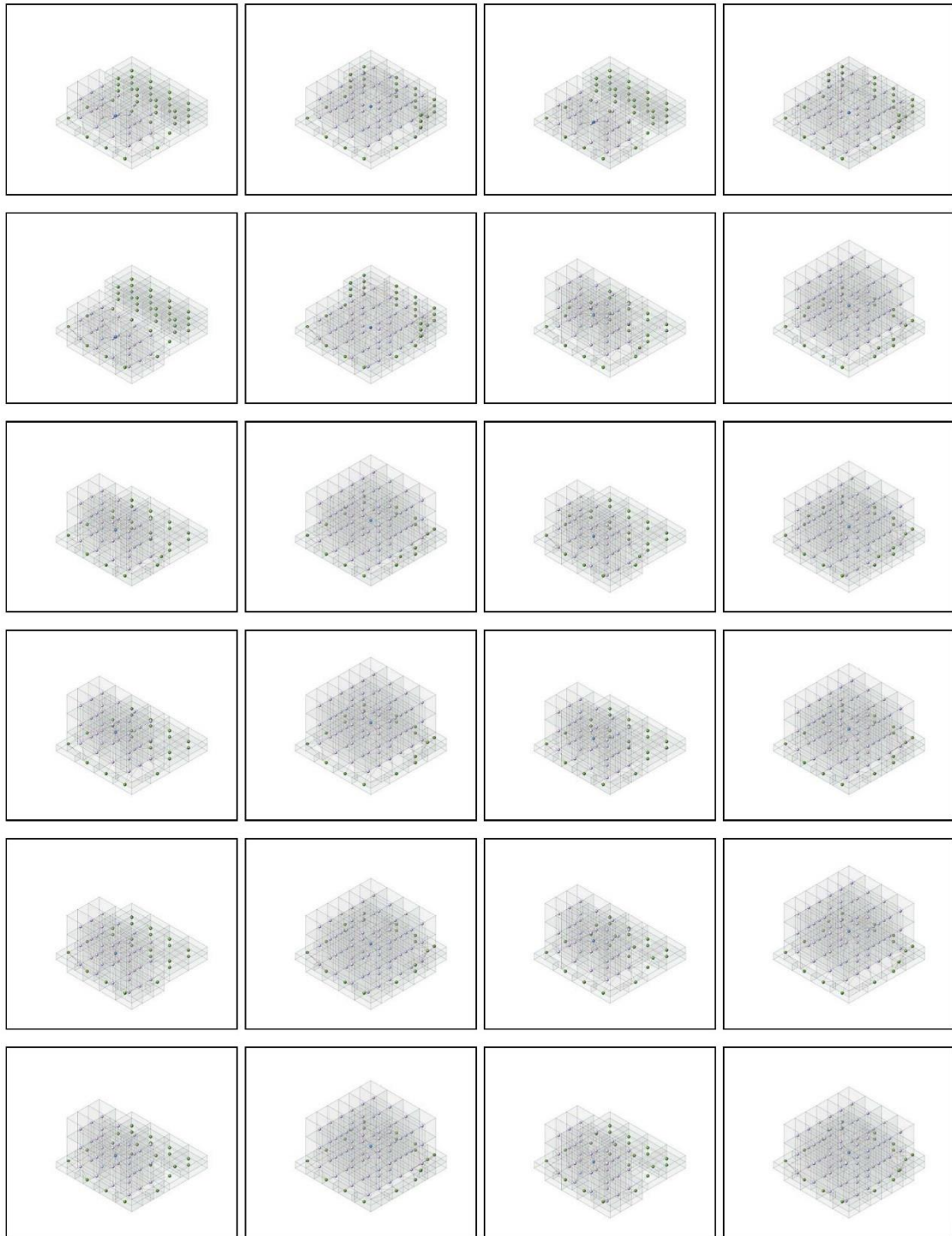

Interlock on 1 Level Ground

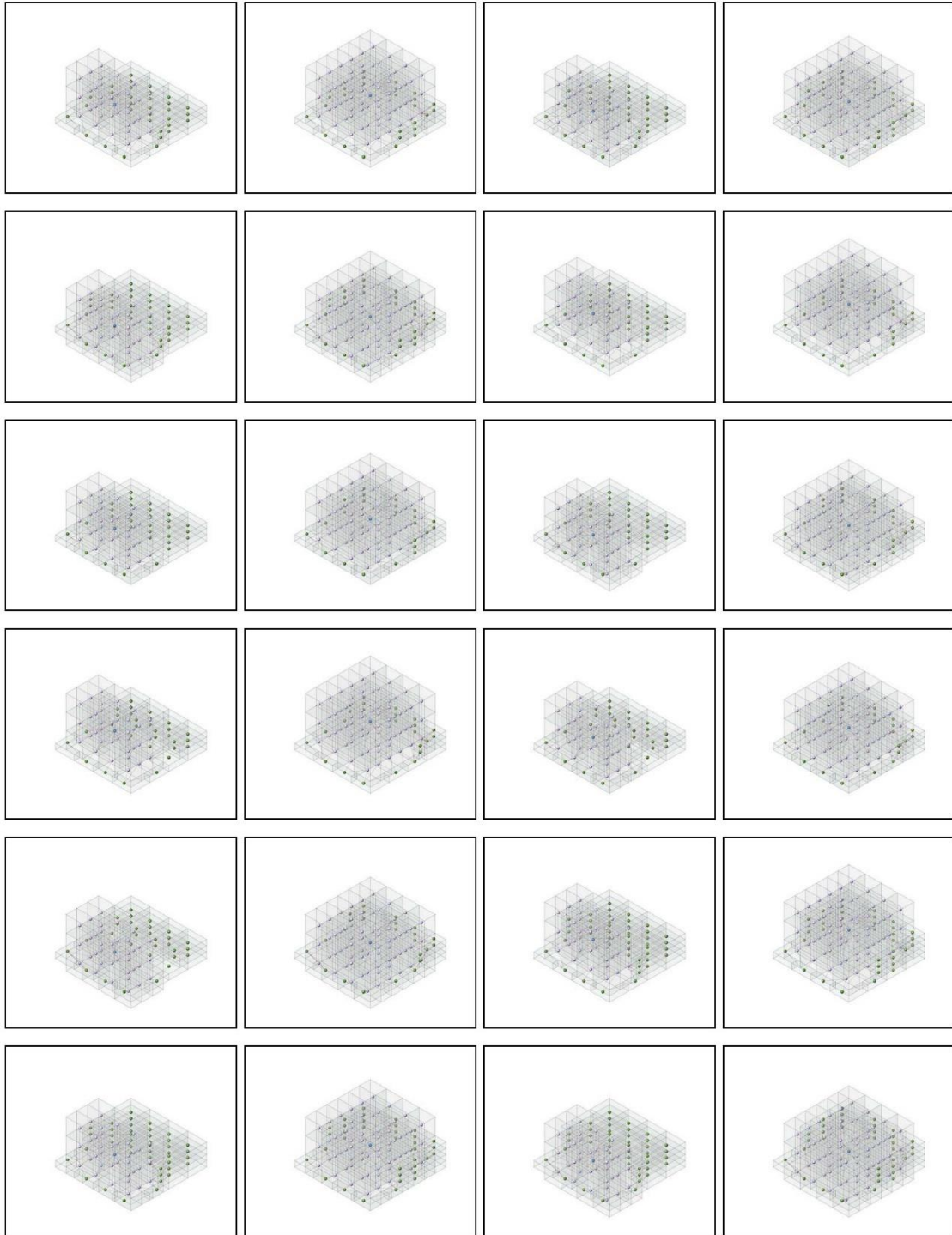

Appendix

Interlock on 1 Level Ground

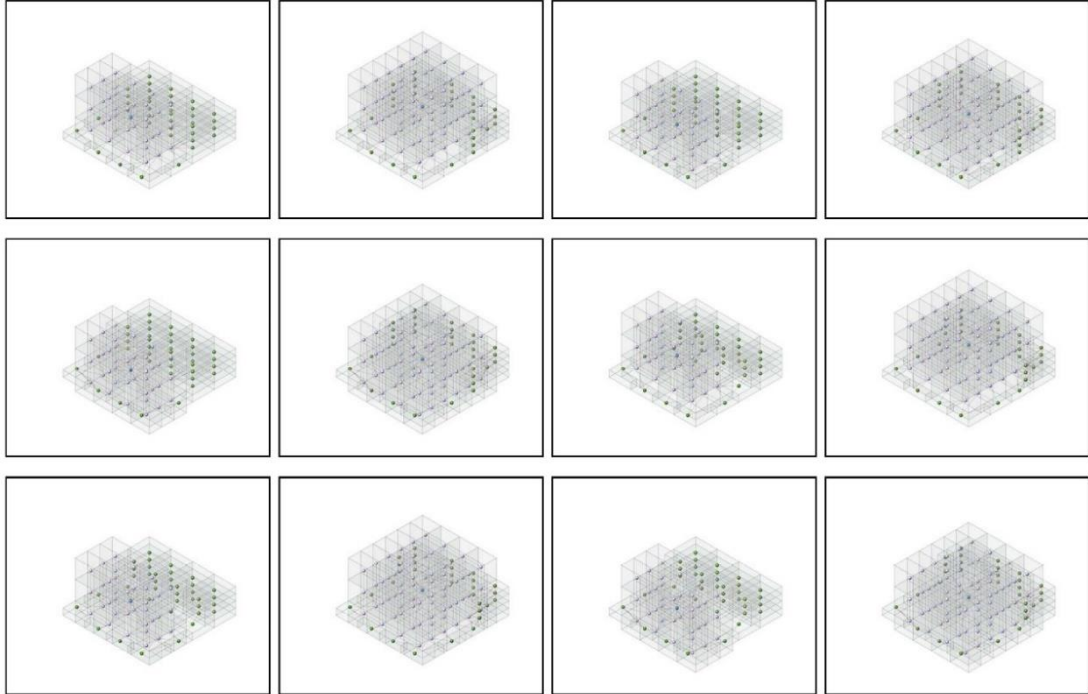

Appendix: XI

The K-Menes, K-Modes and GGM.

Implementation with scikit-learn library

1 Dataset

[83]:

```

import
pandas
as pd
import
numpy as
np
import
sys
dfRaw = pd.read_excel("~/Desktop/Desktop – Abdualrahman’s MacBook Pro/Phd _
↳dissertation/Aconda/5001.xlsx")
dfRaw['Year']=dfRaw['Year'].astype(np.int64)
sys.path.append("~/Desktop/Desktop – Abdualrahman’s MacBook Pro/Phd
↳
↳dissertation/Aconda/5001.xlsx")
from handle_non_numerical_data import handle_non_numerical_data
df,dd=handle_non_numerical_data(dfRaw)
print(df.head())

```

	Architect	Name	Building	Name	Status	Type	Building	Type	Year	\
0		168		334	1	2		0	1958	
1		168		223	1	2		0	1929	
2		168		38	1	2		1	1951	
3		168		11	1	2		1	1930	
4		168		217	1	2		0	1956	

	Continent	Country	City	Period	of history	image	Diagram	Field1	\
0	5	30	152			2	266	20	23
1	0	25	308			1	288	38	11
2	5	30	44			2	17	0	14
3	0	16	342			1	217	29	12
4	5	30	326			2	39	24	23

	Main Relationship	Spacefic Relationship	Touches Ground	\

Appendix

0	1	3	5
1	2	0	6
2	1	3	3
3	0	3	4
4	2	0	6

	Elemental	Relationship	Relation	with	terrain	Metapors	Relationship \
0		2			0		0
1		10			0		2
2		5			0		0
3		0			0		1
4		11			0		2

	Description
0	0
1	0
2	0
3	0
4	0

2 One Hot encoding

[84]:

```
def convert(X,colList):
    for col_name in colList:
        X[col_name] =
            X[col_name].astype(str)
            X=pd.get_dummies(X,prefix=[col
                _name])
    return X
```

```
X = convert(dfRaw,['Main Relationship','Touches Ground','Relation with __
    ↪terrain','Metapors Relationship'])
```

[84]:

	Architect Name	BuildingName	Status	Type	Building Type	Year	\
0	168	334	1	2	0	4.0	
1	168	223	1	2	0	2.0	
2	168	38	1	2	1	4.0	
3	168	11	1	2	1	2.0	
4	168	217	1	2	0	4.0	
--
495	128	242	1	2	1	9.0	
496	188	431	1	2	0	9.0	
497	68	235	0	2	1	9.0	
498	43	267	1	2	1	9.0	
499	43	373	1	2	0	9.0	

	Continent	Country	City	Period of history	...	Touches Ground_5	\
0	5	30	152	2	...	1	
1	0	25	308	1	...	0	

Appendix

2	5	30	44	2	...	0
3	0	16	342	1	...	0
4	5	30	326	2	...	0
--
495	5	30	181	0	...	0
496	4	40	57	0	...	0
497	4	47	198	0	...	0
498	0	12	196	0	...	0
499	0	12	282	0	...	0

	Touches	Ground_6	Relation with terrain_0	Relation with terrain_1	\
0		0	1	0	
1		1	1	0	
2		0	1	0	
3		0	1	0	
4		1	1	0	
--	
495		0	1	0	
496		0	0	0	
497		0	1	0	
498		0	1	0	
499		0	1	0	

	Relation with terrain_2	Relation with terrain_3	\
0	0	0	
1	0	0	
2	0	0	
3	0	0	
4	0	0	
--
495	0	0	
496	1	0	
497	0	0	
498	0	0	
499	0	0	

	Metapors Relationship_0	Metapors Relationship_1	\
0	1	0	
1	0	0	
2	1	0	
3	0	1	
4	0	0	
--
[85]:			
495	0	0	
496	0	0	
497	0	1	
498	0	0	
499	0	0	

Appendix

Relationship_3	Metapors Relationship_2	Metapors
0	0	0
1	1	0
2	0	0
3	0	0
4	1	0
..		

495	1	0
496	0	1
497	0	0
498	1	0
499	1	0

[500 rows x 34 columns]

```
# Select only 2 columns from dataframe and create a new subset DataFrame
X = X [['Touches Ground_0', 'Touches Ground_4', 'Touches Ground_5', 'Touches Ground_6', 'Touches Ground_3', 'Touches Ground_2', 'Touches Ground_1', 'Main Relationship_0', 'Main Relationship_1', 'Main Relationship_2', 'Metapors Relationship_0', 'Metapors Relationship_1', 'Metapors Relationship_2', 'Metapors Relationship_3', 'Relation with terrain_0', 'Relation with terrain_1', 'Relation with terrain_2', 'Relation with terrain_3']]
```

```
X.head(4)
```

[86]:

```
[86]:
```

	Ground_0	Touches Ground_4	Touches Ground_5	Touches Ground_6
0	0	0	1	0
1	0	0	0	1
2	0	0	0	0
3	0	1	0	0

	Ground_3	Touches Ground_2	Touches Ground_1	Main Relationship_0
0	0	0	0	0
1	0	0	0	0
2	1	0	0	0
3	0	0	0	1

	Main Relationship_1	Relationship_2	Metapors Relationship_0
0	1	0	1
1	0	1	0

[88]:

```
print(X.shape)
```

Appendix

(500, 18)

3 Training and Testing data

[89]:

```
msk = np.random.rand(len(df)) < 0.7
xTrain = X [msk]
xTest = X [~msk]
yTrain = X [msk]
yTest = X [~msk]
xTrain.shape
```

[89]: (344, 18)

[90]:

```
print("Input Shape",xTrain.shape)
print("Output Shape",yTrain.shape)
print("Input Shape",xTest.shape)
print("Output Shape",yTest.shape)
```

Input Shape (344, 18)

Output Shape (344, 18)

Input Shape (156, 18)

Output Shape (156, 18)

4 KMeans Clustering

```
from sklearn.cluster import KMeans
kmo = KMeans(n_clusters=4, n_init=10, verbose=1)
trained_model = kmo.fit(xTrain) #training
y_predicted_train=trained_model.predict(xTrain) #testing on Training Data
y_predicted_test=trained_model.predict(xTest) #testing on Testing Data

from sklearn.metrics import silhouette_score
print('Silhouetter Score is:',silhouette_score(xTest,y_predicted_test))
↳#arguments are true_labels predicted_labels number of Clusters

from plot_tsne_Kmeans import plotTsne
pt = plotTsne(xTrain,y_predicted_train,y_predicted_train,kmo.
↳cluster_centers_,isSparse=False) #CO
pt.plot() #p
from yellowbrick.cluster import
KElbowVisualizer model = KMeans()
visualizer = KElbowVisualizer(model, k=(2, 12), metric='silhouette') visualizer.fit(X)
visualizer.show()
```

Iteration 2, inertia

Appendix

240.29405067758685
Converged at iteration 2: strict
convergence. Initialization
complete
Iteration 0, inertia 642.0
Iteration 1, inertia
312.1659492004326 Converged
at iteration 1: strict
convergence. Initialization
complete
Iteration 0, inertia 506.0
Iteration 1, inertia 315.82181230325074
Iteration 2, inertia
312.1659492004326 Converged
at iteration 2: strict
convergence. Initialization
complete
Iteration 0, inertia 320.0
Iteration 1, inertia 240.29405067758685
Converged at iteration 1: strict
convergence. Initialization
complete
Iteration 0, inertia 320.0
Iteration 1, inertia
240.29405067758685
Converged at iteration 1: strict
convergence. Initialization
complete
Iteration 0, inertia 480.0
Iteration 1, inertia
319.40161693357635
Converged at iteration 1: strict
convergence. Initialization
complete
Iteration 0, inertia 320.0
Iteration 1, inertia
240.29405067758685
Converged at iteration 1: strict
convergence. Initialization
complete
Iteration 0, inertia 486.0
Iteration 1, inertia
240.29405067758685
Converged at iteration 1: strict
convergence. Initialization
complete
Iteration 0, inertia 530.0
Iteration 1, inertia 306.71314761602054
Iteration 2, inertia
294.00159200523933 Converged
at iteration 2: strict convergence.
Silhouetter Score is:
0.6670607733820509 (348, 18)
Computing t-
SNE

Appendix

t-SNE embedding of the K-Means Clusters - Numbers(Actual labels) - Colors(Predicted Cluster Index) (time 0.53s)

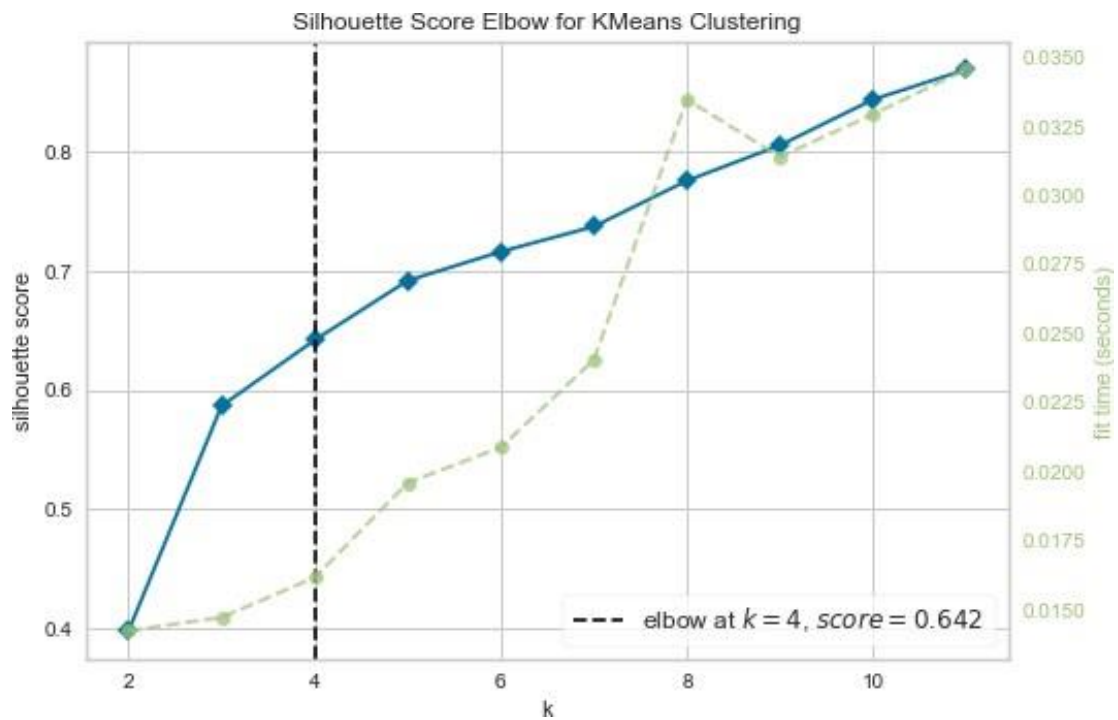

[91]: <AxesSubplot:title={'center': 'Silhouette Score Elbow for KMeans Clustering'}, xlabel='k', ylabel='silhouette score'>

```
[92]  
from yellowbrick.cluster import  
KElbowVisualizer model = KMeans()  
visualizer = KElbowVisualizer(model, k=(2, 12), metric='silhouette') visualizer.fit(X)  
visualizer.show()
```

Appendix

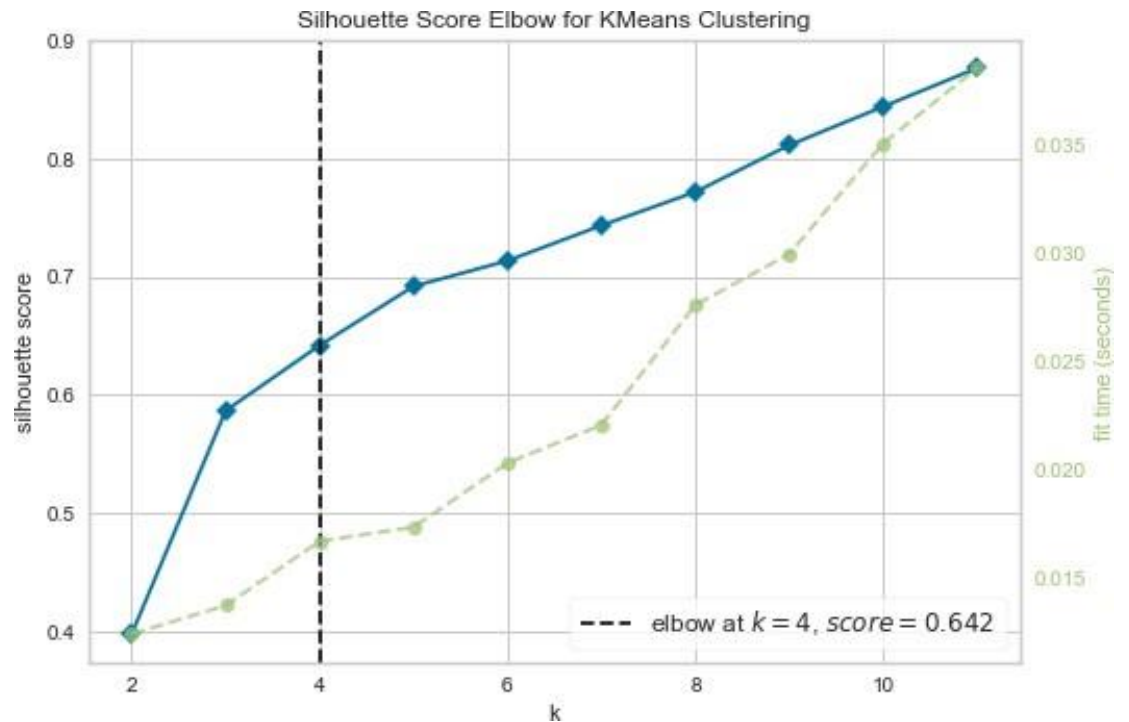

[92]: <AxesSubplot:title={'center': 'Silhouette Score Elbow for KMeans Clustering'}, xlabel='k', ylabel='silhouette score'>

```
#Specify the feature Array here
FeatureList = ['Main Relationship', 'Touches Ground', 'Relation with __
__terrain', 'Metapors Relationship']
num_clusters = 4

def clusterSummary(trained_model,num_clusters,FeatureList,featureData): cluster
= np.round(trained_model.cluster_centers_)
for i in range(num_clusters):
    print("Cluster ",i,":",end="")
    for index,feature in enumerate(FeatureList):
        inv_dd = {v: k for k, v in featureData[feature].items()}
        print(inv_dd[cluster[i,index]],end=" ")
    print("") clusterSummary(trained_model,num_clusters,FeatureList,dd)
```

Cluster 0 :Interlock Absence of level Landing and Grounding Feet on the ground
Cluster1 :Interlock Grounded Landing and Grounding Feet on the ground
Cluster 2 :Interlock Grounded Landing and Grounding Feet on the ground
Cluster3 :Separation Grounded Landing and Grounding Feet on the ground

5 Save Results To Excel - KMeans

```

dfRaw = pd.read_excel("~/Desktop/Desktop – Abdualrahman’s MacBook Pro/Phd _
->dissertation/Aconda/5001.xlsx")
dfTrainRaw = dfRaw[msk] dfTestRaw
= dfRaw[~msk]
def resultInExcel(df,name):
    for i in range(num_clusters):
        df[y_predicted_test=i].to_excel(name+str(i)+".xlsx")
resultInExcel(dfTestRaw,"KM1")

from kmodes.kmodes import KModes
km = KModes(n_clusters=5, init='Huang', n_init=10, verbose=1) msk =
np.random.rand(len(df)) < 0.7
xTrain = X [msk]
xTest = X [~msk]
print(xTrain.shape)
y_pred = km.fit_predict(xTrain)
print('Silhouetter Score is:{}'.format(silhouette_score(xTrain,y_pred)))
from plot_tsne_Kmeans import plotTsne
pt = plotTsne(xTrain,y_pred,y_pred,km.cluster_centroids_,isSparse=False) #CO
pt.plot() #p

```

```

(346, 18)
Init:
initializing
centroids
Init:
initializing
clusters
Starting
iterations
...
Run 1, iteration: 1/100, moves: 4, cost: 228.0
Run 1, iteration: 2/100, moves:
0, cost: 228.0 Init: initializing
centroids
Init:
initializing
clusters
Starting
iterations
...
Run 2, iteration: 1/100, moves: 16, cost: 264.0
Run 2, iteration: 2/100, moves:
2, cost: 264.0 Init: initializing
centroids
Init:
initializing
clusters
Starting
iterations
...
Run 3, iteration: 1/100, moves: 6, cost: 382.0
Run 3, iteration: 2/100, moves:
0, cost: 382.0 Init: initializing
centroids

```

Appendix

Init:
initializing
clusters
Starting
iterations
...

Run 4, iteration: 1/100, moves: 94, cost: 288.0

Run 4, iteration: 2/100, moves:
2, cost: 288.0 Init: initializing
centroids

Init:
initializing
clusters
Starting
iterations

...

Run 5, iteration: 1/100, moves:
0, cost: 391.0 Init: initializing
centroids

Init:
initializing
clusters
Starting
iterations

...

Run 6, iteration: 1/100, moves: 10, cost: 288.0

Run 6, iteration: 2/100, moves:
0, cost: 288.0 Init: initializing
centroids

Init:
initializing
clusters
Starting
iterations

...

Run 7, iteration: 1/100, moves: 90, cost: 423.0

Run 7, iteration: 2/100, moves:
2, cost: 423.0 Init: initializing
centroids

Init:
initializing
clusters
Starting
iterations

...

Run 8, iteration: 1/100, moves:
0, cost: 242.0 Init: initializing
centroids

Init:
initializing
clusters
Starting
iterations

...

Run 9, iteration: 1/100, moves: 4, cost: 288.0

Run 9, iteration: 2/100, moves:
0, cost: 288.0 Init: initializing
centroids

Init:
initializing
clusters
Starting

Appendix

iterations

...

Run 10, iteration: 1/100, moves: 18, cost: 242.0

Run 10, iteration: 2/100, moves: 0,
cost: 242.0 Best run was number 1

Silhouetter Score

is:0.698129692869855 (351,
18)

Computing t-

SNE

embedding

Hello

t-SNE embedding of the K-Means Clusters - Numbers(Actual labels) - Colors(Predicted Cluster Index) (time 0.94s)

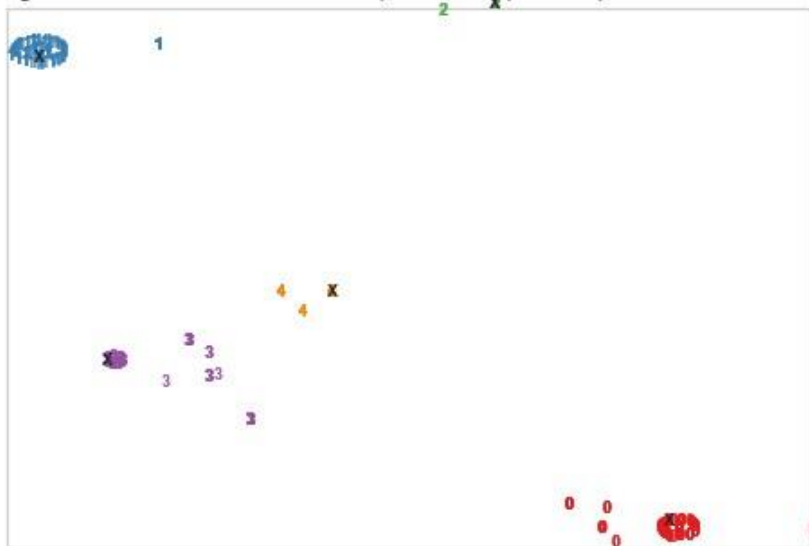

```
km.cluster_centroids_
```

[96]:

```
[96]: array([[0, 0, 0, 0, 0, 1, 0, 0, 1, 0, 1, 0, 0, 0, 1, 0,
              0, 0],
          [0, 0, 0, 0, 0, 0, 1, 0, 0, 1, 0, 0, 1, 0, 1, 0, 0, 0],
          [0, 0, 0, 1, 0, 0, 0, 0, 0, 1, 0, 0, 1, 0, 1, 0, 0, 0],
          [0, 1, 0, 0, 0, 0, 0, 1, 0, 0, 0, 1, 0, 0, 0, 1, 0, 0],
          [1, 0, 0, 0, 0, 0, 0, 1, 0, 0, 0, 0, 0, 0, 1, 0, 0, 1, 0]],
      dtype=uint8)
```

```
from yellowbrick.cluster import
KElbowVisualizer model = KModes()
visualizer = KElbowVisualizer(model, k=(2, 12), metric='silhouette') visualizer.fit(X)
visualizer.show()
```

[97]:

Appendix

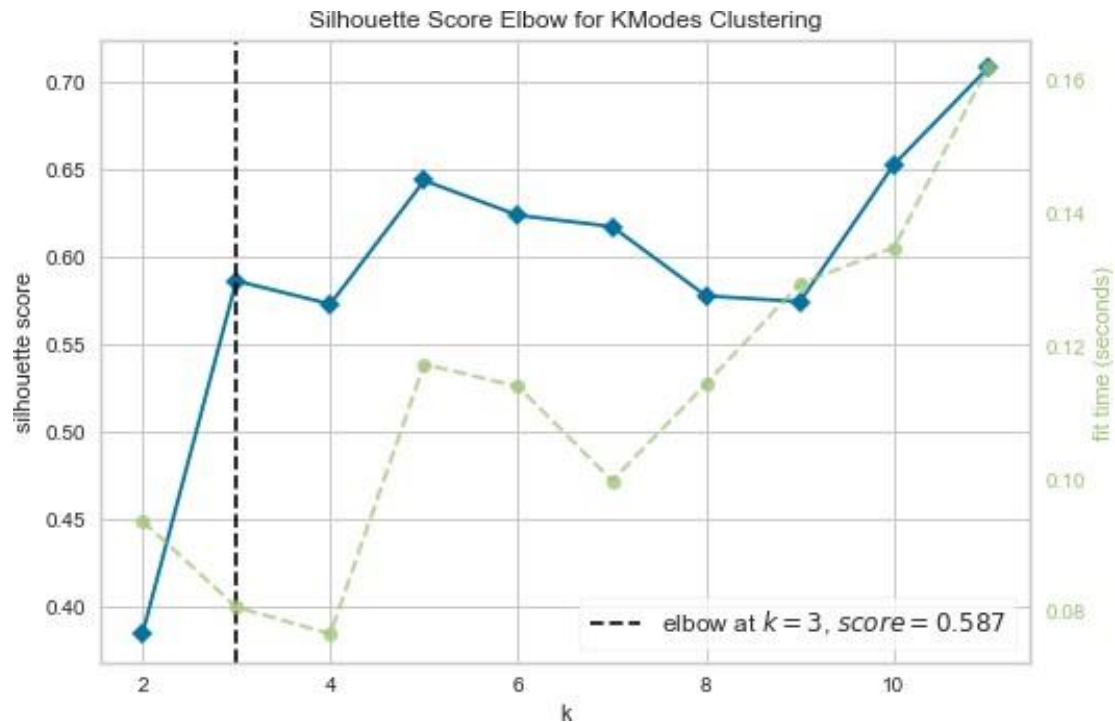

[97]: <AxesSubplot:title={'center': 'Silhouette Score Elbow for KModes Clustering'}, xlabel='k', ylabel='silhouette score'>

7 Gaussian Mixture Models

```
from sklearn.mixture import GaussianMixture
#Gaussian Mixture Model
gmm = GaussianMixture(n_components=4)
gmm.fit(xTrain)
proba_lists = gmm.predict_proba(xTrain)
y_predicted_train = gmm.predict(xTrain)
```

[98]:

```
import scipy
X = xTrain
centers = np.empty(shape=(gmm.n_components, X.shape[1]))
#print(centers.shape)
#print(X[:6])
for i in range(gmm.n_components):
    density = scipy.stats.multivariate_normal(cov=gmm.covariances_[i], mean=gmm.
    ↪means_[i]).logpdf(X)
    centers[i, :] = X.iloc[np.argmax(density)]
```

[99]:

```
proba_lists.shape
```

```
[100]:
```

```
[100]: (346, 4)
```

```
[101]:
```

```
from plot_tsne import plotTsne  
pt = plotTsne(xTrain,y_predicted_train,isSparse=False) #CO  
pt.plot() #p
```

Computing t-SNE
embedding Hello

t-SNE embedding of the Malware And CleanWare (time 0.54s)

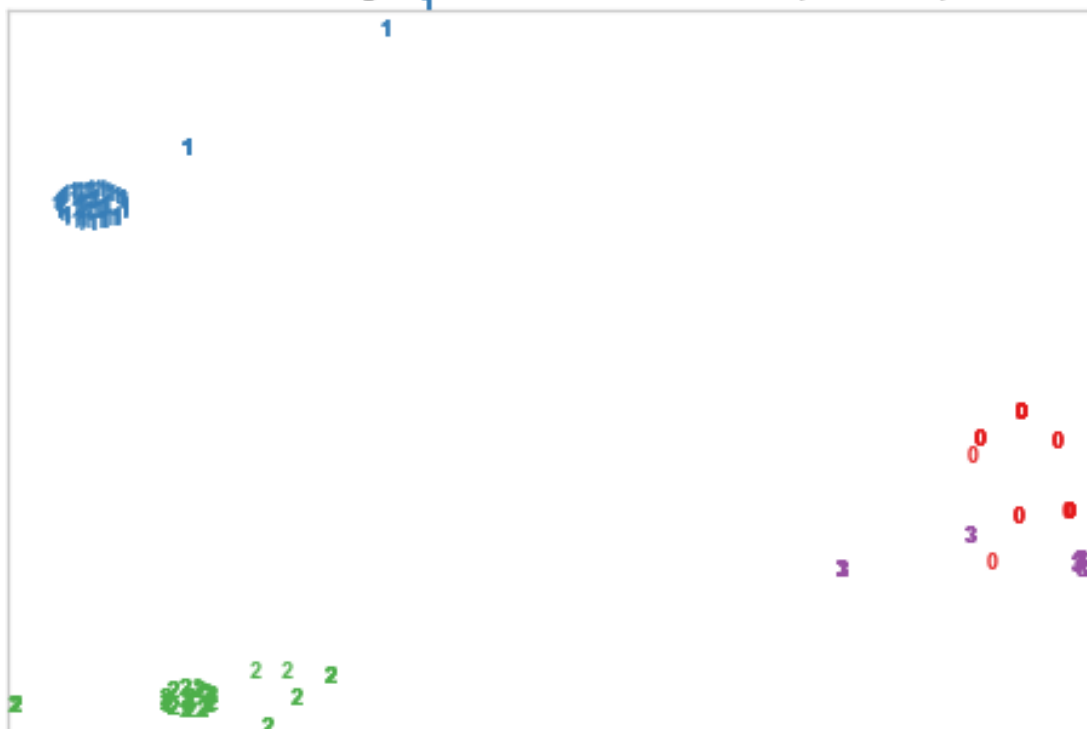

```
#Specify the feature Array here  
FeatureList = ['Main Relationship', 'Touches Ground', 'Relation with __  
_terrain', 'Metapors Relationship']  
num_clusters = 3
```

```
def  
clusterSummary(trained_model,num_clusters,FeatureList,featureData)  
: cluster = np.round(trained_model.cluster_centers_)  
for i in  
range(num_clusters):  
print("Cluster  
",i,":",end="")  
print(inv_dd[cluster[i,index]],end=" ")  
print("")
```

```
clusterSummary(trained_model,num_clusters,FeatureList,dd)
```

Appendix

```
from yellowbrick.cluster import
KElbowVisualizer model = KMeans()
visualizer = KElbowVisualizer(model, k=(2, 12), metric='silhouette') visualizer.fit(X)
visualizer.show()
```

Cluster 0 :Interlock Absence of level Landing and Grounding Feet on the ground
Cluster 1 :Interlock Grounded Landing and Grounding Feet on the ground
Cluster 2 :Interlock Grounded Landing and Grounding Feet on the ground

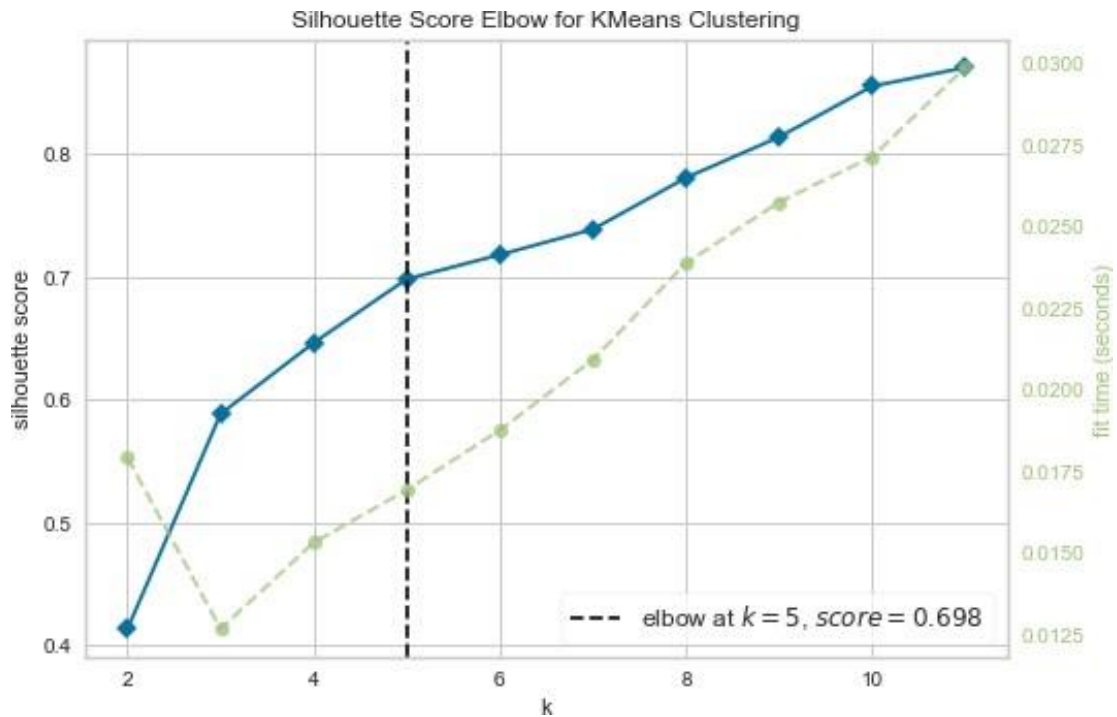

[105]: <AxesSubplot:title={'center':'Silhouette Score Elbow for KMeans Clustering'},
xlabel='k', ylabel='silhouette sco

Appendix: XII
DGCNN implementation using
PyTorch geometric

Appendix

INSTALL DGCNN CODES

1. Follow the installation in the link:

https://github.com/muhanzhang/pytorch_DGCNN

RUN THE DGCNN - TRAINING MODE

2. Open the file run_DGCNN.sh and modify the hyperparameters in the file such as:

```
1. #!/bin/bash
2. # input arguments
3. DATA="${1-MUTAG}" # MUTAG, ENZYMES, NCI1, NCI109, DD, PTC, PROTEINS, COLLAB, IMDBBINARY, IMDBMULTI
4. fold=${2-1} # which fold as testing data
5. test_number=${3-0} # if specified, use the last test_number graphs as test data
6. # general settings
7. gm=DGCNN # model
8. gpu_or_cpu=cpu
9. GPU=0 # select the GPU number
10. CONV_SIZE="32-32-32-1"
11. sortpooling_k=0.6 # If k <= 1, then k is set to an integer so that k% of graphs have nodes less than this integer
12. FP_LEN=0 # final dense layer's input dimension, decided by data
13. n_hidden=128 # final dense layer's hidden size
14. bsize=50 # batch size, set to 50 or 100 to accelerate training
15. dropout=True
16. # dataset-specific settings
17. case ${DATA} in
18. *)
19. num_epochs=500
20. learning_rate=0.00001
21. ;;
22. esac
```

3. In the Terminal type the following:

```
1. (Pytorch) pytorch_DGCNN > cd lib
2. (Pytorch) pytorch_DGCNN\lib > make clean
3. (Pytorch) pytorch_DGCNN\lib > make -j4
4. (Pytorch) pytorch_DGCNN > cd ..
```

4. DGCNN is run by typing ./run_DGCNN.sh, followed by the folder number, data name, and the amount of training graphs. You can only test with one graph if you wish to only train.

For instance

5. (Pytorch) pytorch_DGCNN > ./run_DGCNN.sh DIT 1 1

6. The model will start running with the parameters set.

```
1. (Pytorch) pytorch_DGCNN > ./run_DGCNN.sh DIT 1 10
2. ===== begin of gnn configuration =====
3. | msg_average = 0
4. ===== end of gnn configuration =====
5. Namespace(batch_size=1, conv1d_activation='ReLU', data='DIT', dropout=True, edge_feat_dim=0,
extract_features=False, feat_dim=0, fold=1, gm='DGCNN', hidden=128, latent_dim=[32, 32, 32, 1],
learning_rate=0.001, max_lv=4, mode='cpu', num_class=0, num_epochs=10, out_dim=0, predict=False,
printAUC=False, seed=1, sortpooling_k=0.6, test_number=10)
6. loading data
7. # classes: 5
8. # maximum node tag: 3
```

Appendix

```
9. {4: 0, 0: 1, 1: 2, 3: 3, 2: 4}
10. # train: 1486, # test: 10
11. k used in SortPooling is: 81
12. Initializing DGCNN
13. loss: 1.03576 acc: 0.46000: 100% | ██████████ | 9/9 [00:07<00:00, 1.22batch/s]
14. average training of epoch 0: loss 1.22081 acc 0.46222 auc 0.00000
15. loss: 1.10277 acc: 0.40000: 100% | ██████████ | 1/1 [00:00<00:00, 33.32batch/s]
16. average test of epoch 0: loss 1.10277 acc 0.40000 auc 0.00000
17. loss: 0.96427 acc: 0.54000: 100% | ██████████ | 9/9 [00:06<00:00, 1.38batch/s]
18. average training of epoch 1: loss 1.01402 acc 0.45333 auc 0.00000
19. loss: 1.11303 acc: 0.40000: 100% | ██████████ | 1/1 [00:00<00:00, 24.75batch/s]
```

7. After the model has finished training, the trained model will be saved in the /saved_model directory.
8. The results of the test graphs in the file [DATA_NAME]_acc_results can be viewed in the file '[DATA_NAME]_acc_results'. For the trained model, this document contains epoch, loss, accuracy, and acc.
9. To plot the trained model, type the following in the command line in the same directory.

```
(Pytorch) pytorch_DGCNN > python plot.py
```

TO RUN THE DGCNN - TRAINING MODE

1. To use predict with DGCNN, a saved and trained model must be present in the saved_model/ directory. To proceed, must first modify the file. 'run_DGCNN.sh'. On line 17, add the parameter predict = True after dropout. Other parameters should not be changed.

```
1. #!/bin/bash
2. # input arguments
3. DATA="${1-MUTAG}" # MUTAG, ENZYMES, NCI1, NCI109, DD, PTC, PROTEINS, COLLAB, IMDBBINARY, IMDBMULTI
4. fold=${2-1} # which fold as testing data
5. test_number=${3-0} # if specified, use the last test_number graphs as test data
6. # general settings
7. gm=DGCNN # model
8. gpu_or_cpu=cpu
9. GPU=0 # select the GPU number
10. CONV_SIZE="32-32-32-1"
11. sortpooling_k=0.6 # If k <= 1, then k is set to an integer so that k% of graphs have nodes less than this integer
12. FP_LEN=0 # final dense layer's input dimension, decided by data
13. n_hidden=128 # final dense layer's hidden size
14. bsize=50 # batch size, set to 50 or 100 to accelerate training
15. dropout=True
16. predict=False
17. # dataset-specific settings
18. case ${DATA} in
19. *)v
```

2. At the bottom of the 'run_DGCNN.sh' file, add -predict \$predict / below the list of CUDA_VISIBLE_DEVICES.

```
1. CUDA_VISIBLE_DEVICES=${GPU} python main.py \
2. -seed 1 \
```

Appendix

```
3. -data $DATA \  
4. -fold $fold \  
5. -learning_rate $learning_rate \  
6. -num_epochs $num_epochs \  
7. -hidden $n_hidden \  
8. -latent_dim $CONV_SIZE \  
9. -sortpooling_k $sortpooling_k \  
10. -out_dim $FP_LEN \  
11. -batch_size $bsize \  
12. -gm $gm \  
13. -mode $gpu_or_cpu \  
14. -dropout $dropout \  
15. -predict $predict \  
16. -test_number ${test_number}
```

3. The saved model name to be used for prediction should be the same as that in line 210 of the main file.

```
1. if cmd_args.predict:  
2. classifier = Classifier()  
3. if cmd_args.mode == 'gpu':  
4. classifier = classifier.cuda()  
5. model_name = 'saved_model/test1.bin'  
6. classifier.load_state_dict(torch.load(model_name))
```

4. The code can now be re-run in the terminal. In a similar manner to train mode, type the following:

```
1. (Pytorch) pytorch_DGCNN > ./run_DGCNN.sh DIT-PREDICT 1 10
```

5. After the code finishes running, the terminal will print the results for the prediction, with the probability distribution of the classifications present in the data.

```
1. Namespace(batch_size=1, conv1d_activation='ReLU', data='DIT', dropout=True, edge_feat_dim=0,  
extract_features=False, feat_dim=0, fold=1, gm='DGCNN', hidden=128, latent_dim=[32, 32, 1], learning_rate=0.0001,  
max_lv=4, mode='cpu', num_class=0, num_epochs=200, out_dim=0, predict=True, printAUC=False, seed=1,  
sortpooling_k=0.6, test_number=39)  
2. loading data  
3. # classes: 5  
4. # maximum node tag: 5  
5. {4: 0, 0: 1, 1: 2, 3: 3, 2: 4}  
6. # train: 1936, # test: 39  
7. k used in SortPooling is: 81  
8. Initializing DGCNN  
9. {4: 0, 0: 1, 1: 2, 3: 3, 2: 4}  
10. [[0. 1. 0. 0. 0. ]  
11. [0. 0. 1. 0. 0. ]  
12. [0. 0. 1. 0. 0. ]  
13. [0. 1. 0. 0. 0. ]  
14. [1. 0. 0. 0. 0. ]  
15. ..  
16. [0.0182 0. 0. 0. 0.9818]  
17. [1. 0. 0. 0. 0. ]  
18. [1. 0. 0. 0. 0. ]  
19. [0. 0. 1. 0. 0. ]  
20. [0. 1. 0. 0. 0. ]  
21. Predictions for DIT are saved in data/DIT_pred.txt
```

Appendix: XIII
System Usability Scale (SUS)
Ethical Approval Forms

Appendix

07/04/2022

Dear Abdulrahman Alymani

Research project title: System Usability Scale (SUS) of Using Proposed Workflow of Building/Ground Relationship.

SREC reference: 2216

The Welsh School of Architecture's Research Ethics Committee ('Committee') reviewed the above application via its proportionate review process.

Ethical Opinion

The Committee gave

- B a favourable ethical opinion of the above application on the basis described in the application form, protocol and supporting documentation, **subject to the conditions** specified below.

Conditions of the favourable opinion

The favourable opinion is subject to the following conditions being met prior to the start of the research project.

- Please combine the consent form and questionnaire as one Google document. This ensures that consent is given for all questionnaires.
- To comply with your answer to 6.3, please allow the option for participants to omit answering questions. Currently all questions on the Google docs form are marked as required and the participants cannot proceed until the answer all.
- Photographs of participants must either be taken in such a way that individual cannot be easily identified or post editing software should be used to blur faces.
- Please provide evidence of completing the University's online research integrity training. This can be accessed [here](#).

Whilst the Committee does not propose to conduct a further review of your application/revised research project documents following implementation of the conditions above, you should notify the Committee once all conditions have been met and provide copies of any revised documentation with updated version numbers before the research commences.

Additional approvals

This letter provides an ethical opinion only. You must not start your research project until all appropriate approvals are in place.

Amendments

Any substantial amendments to documents previously reviewed by the Committee must be submitted to the Committee via ARCHI-ethics@cardiff.ac.uk for consideration and cannot be implemented until the Committee has confirmed it is satisfied with the proposed amendments.

You are permitted to implement non-substantial amendments to the documents previously reviewed by the Committee but you must provide a copy of any updated documents to the Committee via ARCHI-ethics@cardiff.ac.uk for its records.

Appendix

Monitoring requirements

The Committee must be informed of any unexpected ethical issues or unexpected adverse events that arise during the research project.

The Committee must be informed when your research project has ended. This notification should be made to ARCHI-ethics@cardiff.ac.uk within three months of research project completion. For Student projects, submission of the associated dissertation will be considered to be notification.

Documents reviewed by Committee

The documents reviewed by the Committee were:

Document	Version	Date
WSA_Ethics-Review-Application-Proforma_2021_RevA	A	06/04/22
Links to consent form and questionnaire on Google Forms		
SUS Q.pdf	1	

Complaints/Appeals

If you are dissatisfied with the decision made by the Committee, please contact the Chair of the Committee via ARCHI-ethics@cardiff.ac.uk in the first instance to discuss your complaint. If this discussion does not resolve the issue, you are entitled to refer the matter to the Head of School for further consideration. The Head of School may refer the matter to the University Open Research Integrity and Ethics Committee (ORIEC), where this is appropriate. Please be advised that ORIEC will not normally interfere with a decision of the Committee and is concerned only with the general principles of natural justice, reasonableness and fairness of the decision.

Please use the Committee reference number on all future correspondence.

The Committee reminds you that it is your responsibility to conduct your research project to the highest ethical standards and to keep all ethical issues arising from your research project under regular review.

You are expected to comply with Cardiff University's policies, procedures and guidance at all times, including, but not limited to, its [Policy on the Ethical Conduct of Research involving Human Participants](#), Human Material or Human Data and our Research Integrity and Governance Code of Practice.

abdurahmanalymani
CONFIDENTIAL

Dr Chris Whitman

**Senior Lecturer
School Ethics Officer and Research Integrity
Lead**
Welsh School of Architecture
Cardiff University
Bute Building
King Edward VII Avenue
Cardiff CF10 3NB
Wales U.K.
Tel: +44 (0)29 2087 5893
Email: WhitmanCJ@Cardiff.ac.uk

**Uwch Ddarlithydd
Swyddog Moeseg yr Ysgol ac
Arweinydd Gonestrwydd Ymchwil**
Ysgol Pensaernïaeth Cymru
Prifysgol Caerdydd
Adeilad Bute
Rhodfa'r Brenin Edward VII
Caerdydd CF10 3NB
Cymru D.U.
Ffôn : +44 (0)29 2087 5893
E-bost: WhitmanCJ@Cardiff.ac.uk