

Design and Fabrication of an Electrochemical Microreactor and its Use in Electroorganic Synthesis

Kevin George Watts

PhD Thesis 2013

Table of Contents

Abstract	v
Abbreviations	vi-viii
Acknowledgements	ix
1. General introduction	
1. Electroorganic chemistry.....	2
1.1 History of electrochemistry.....	2
1.2 Industrial electrochemistry.....	4
1.3 Fundamentals.....	6
1.4 Electrode reactions.....	7
1.5 Physical phenomena.....	9
1.5.1 The electrochemical double layer.....	9
1.5.2 Mass transport.....	11
1.5.2.1 Diffusion.....	12
1.5.2.2 Migration.....	12
1.5.2.3 Convection.....	12
1.6 Methods of electrolysis.....	13
1.6.1 Controlled potential electrolysis.....	13
1.6.2 Controlled current electrolysis.....	14
1.7 Cell design.....	17
1.7.1 Batch cells.....	17
1.7.1.1 Undivided cells.....	17
1.7.1.2 Divided cells.....	18
1.7.2 Flow through cells.....	19
1.7.3 Electrode materials.....	19
1.7.4 Reference electrodes.....	21
1.7.5 Diaphragms.....	22
1.8 Solvent effects.....	22
1.8.1 Protic solvents.....	23
1.8.2 Aprotic solvents.....	24
1.9 Supporting electrolytes.....	24

1.9.1	Anionic.....	25
1.9.2	Cationic.....	25
1.10	Electrochemical intermediates and reactions.....	26
1.10.1	Direct intermediate formation.....	27
1.10.1.1	Carbon-carbon bond formation.....	27
1.10.1.1.1	Polar/Umpolung reactions.....	27
1.10.1.1.2	Radical carbon-carbon bond formation.....	29
1.10.1.2	Functional group interconversion.....	30
1.10.2	Indirect electrochemistry.....	32
2.	Microreactors for organic synthesis.....	34
2.1	Introduction to flow chemistry.....	34
2.2	Microreactor set-up.....	34
2.3	Chip/reactor design.....	36
2.4	Advantages of flow chemistry.....	37
2.4.1	Efficient mixing.....	38
2.4.2	Heat management.....	41
2.4.3	Specific control of residence times.....	43
2.4.4	Handling dangerous compounds.....	44
2.4.5	Multi-step syntheses.....	45
2.4.6	Online analysis and self optimising techniques.....	46
2.4.7	Scaling up reactions.....	48
2.5	Pumping techniques.....	49
2.6	Interfacial reactions.....	50
3.	Electrochemical microreactors.....	51
3.1	Advantages of electrochemical microreactors.....	51
3.2	Designs of electrochemical microreactors.....	53
3.2.1	Plate to plate electrodes.....	53
3.2.2	Divided cell microreactors.....	60
3.2.3	Interdigitated band electrodes.....	64
4.	References.....	66
2.	Design and fabrication of an electrochemical microreactor	
2.1	Construction and testing of a prototype.....	73
2.2	Conclusions.....	83
2.3	Experimental.....	85

2.4	References.....	86
3.	Electrochemical synthesis of diaryliodonium salts in flow	
3.1	Introduction.....	91
3.1.1	Synthetic routes to diaryliodonium salts.....	93
3.1.2	Applications of diaryliodonium salts.....	96
3.1.3	Electrosynthesis of diaryliodonium salts.....	97
3.2	Results and discussion.....	100
3.3	Conclusions.....	104
3.4	Experimental.....	105
3.5	References.....	109
4.	The synthesis of carbamates via a Hofmann rearrangement and the use of electrochemical mediators in flow	
4.1	Introduction.....	113
4.2	Electrochemically induced Hofmann rearrangement.....	119
4.3	Results and discussion.....	122
4.3.1	Electrochemically induced Hofmann rearrangement in flow.....	122
4.3.2	Electrogenerated bases.....	129
4.3.3	Oxidation of alcohols in flow.....	132
4.4	Conclusions.....	136
4.5	Experimental.....	137
5.6	References.....	142
5.	Electrochemical trifluoromethylation of olefins in flow	
5.1	Introduction.....	146
5.1.1	Fluorine in nature and society.....	146
5.1.2	Fluorine in medicine.....	149
5.2	Methods of fluorination.....	152
5.2.1	Direct fluorination.....	152
5.2.2	Electrochemical fluorination.....	157
5.2.3	The “Building block” method.....	159
5.2.4	Fluorinations using microreactors.....	161
5.3	Results and discussion.....	164
5.3.1	Bistrifluoromethylation.....	166
5.3.2	Dimerisation.....	170
5.3.3	Hydrotrifluoromethylation.....	174

5.3.4 Substitution.....	178
5.3.5 Trifluoromethylacetamidation.....	179
5.4 Conclusions.....	181
5.5 Experimental.....	181
5.6 References.....	185
6. Conclusions.....	189
7. Appendices	
7.1 Part A schematic.....	192
7.2 Part B schematic.....	193

Abstract

Organic electrochemistry provides a straight forward and efficient method for the generation of a wide variety of reactive intermediates. It does however; suffer from limitations such as the need for supporting electrolytes. The scale up process can also be difficult from preparative to large scale batch syntheses.

Interest in the field of microreactor technology has grown over the last 10 to 20 years. This is due to increasing efforts in making organic chemistry a “greener” process, using less solvents and expensive chemical reagents. Combining these two fields of chemistry provides a platform for making organic electrochemistry more appealing to chemists and industry, although the technology is still in its infancy.

As there are no commercially available microreactors for electroorganic synthesis, one has been designed and fabricated before it can be used for electroorganic syntheses in a flow environment.

Abbreviations

AcOH - Acetic acid

Br- Broad

Calcd - Calculated

DABCO - 1,4-diazabicyclo[2.2.2]octane

DAST – diethylaminosulfur trifluoride

DBU - 1,8-Diazabicyclo[5.4.0]undec-7-ene

DME – Dropping mercury electrode

DMF - N,N-Dimethylformamide

DMP – Dess-Martin periodinane

DMSO - Dimethyl sulfoxide

EGB – Electrogenerated base

EHD - Electrohydrodimerisation

EWG – Electron withdrawing group

EI – Electron impact

Eq. - Equivalent

FEP – Fluorinated ethylene propylene

FTMS – Fourier transform mass spectrometry

GCMS – Gas chromatography mass spectrometry

GLC – Gas-liquid chromatography

h - Hour

HPLC – High performance liquid chromatography

HRMS – High resolution mass spectrometry

IBX – Iodoxybenzoic acid

IR – Infrared

J – Coupling constant (Hz)

Lit. - Literature

m-CPBA – *m*-chloroperbenzoic acid

m - Multiplet

Min – minute

Mol - Mole

m.p – melting point

NBS - *N*-Bromosuccinimide

NFSI – *N*-fluorobenzenesulfonimide

NMR – Nuclear magnetic resonance

NSI – Nanospray ionisation

PEEK – Polyether ether ketone

PET – Positron emission tomography

PIDA – (Diacetoxyiodo)benzene

Ppm – Parts per million

PTFE – Polytetrafluoroethylene

RT – Room temperature

s - Singlet

SPS – Solvent purification system

SET – Solution electron transfer

SCE – Standard calomel electrode

TBACl – Tetrabutylammonium chloride

TBAF – Tetrabutylammonium fluoride

TBAI – Tetrabutylammonium iodide

TEAB – Tetraethylammonium bromide

TEMPO - 2,2,6,6-Tetramethylpiperidinyloxy

TFA – Trifluoroacetic acid

TLC – Thin layer chromatography

TOF – Time of flight

UV – Ultraviolet

Acknowledgements

Firstly I would like to thank my supervisor at Cardiff University, Thomas Wirth, for the opportunity to study and help throughout the project. I would also like to thank my industrial supervisor Will Gattrell of Prosidion Ltd for the opportunity to spend time at the company.

Many thanks to Professor David Barrow of Cardiff School of Engineering for help designing the microreactor, and a big thank you to Alun, John and Steve of the chemistry workshop for help fabricating the microreactor and continual assistance throughout the project, and also to the other support staff.

I would also like to thank the Wirth group members, past and present: Guillaume, Mat, Baker, Rich, Mike, Umar, Pushpak, and the many other people I have spent time with at Cardiff University.

One last thank you to all of my family who have supported me for the duration of my time at Cardiff University.

Chapter 1

General Introduction

1. Electroorganic chemistry

1.1. History of electroorganic chemistry

Historically electrochemistry was born in 1800 when Alessandro Volta invented the first electric battery¹ that could supply a current to an electric circuit making the field a possibility. It was also in this year that the first electrochemical reaction was reported, the decomposition of water to oxygen and hydrogen reported by Nicholson.² However, the first electroorganic synthesis was reported by Faraday much later in 1834 showing that after electrolysis of an acetate salt the products were found to be carbon dioxide and ethane when conducted on platinum electrodes (Scheme 1.1).^{3,4}

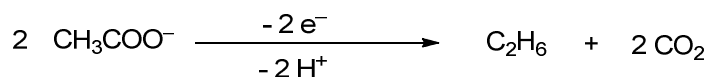

Scheme 1.1: The first electroorganic synthesis

In 1848 perhaps the best known electroorganic synthesis was discovered and reported by Kolbe.⁵ He discovered that during anodic oxidation fatty acids and half-esters of dicarboxylic acids undergo decarboxylation to give alkyl radicals. These radicals can then dimerise yielding alkanes, a relatively easy method for C-C bond formation (Scheme 1.2).

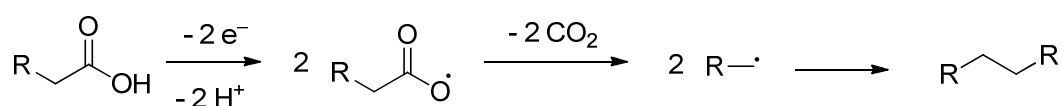

Scheme 1.2: The Kolbe Electrolysis reaction

Although electroorganic chemistry had begun as its own area of chemistry, it didn't really take off until around 1960.^{6,7} To depict this, references in the area of electroorganic synthesis are shown in the graph below (Figure 1.1). From the early 1900s the number of publications released each year was less than 10, and then from 1950 to today the increase in the number of publications a year has risen dramatically to more than 1100 papers published 2012. This can mainly be attributed to the fact that before 1960, much of the electrochemical equipment that today we

take for granted such as reliable sources of electrical current and methods of analysis were in their infancy or did not exist in the period.

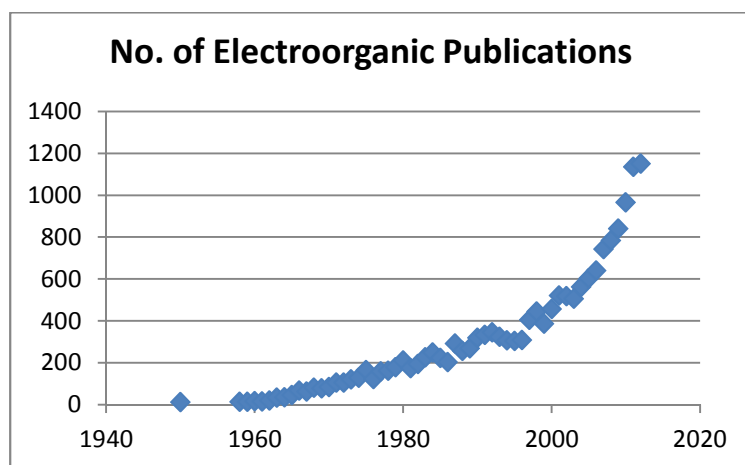

Figure 1.1: The increase of electroorganic papers published

Over the last 10 to 20 years a huge increase in interest to electroorganic chemistry has been observed. This is not only due to the advances in equipment and understanding of electrochemical reactions, but also because of the advantages it can offer to organic synthesis:^{6,8-10}

- It is a clean method for the generation of electrons.
- Many reactive intermediates can be formed at the electrodes from neutral substrates. Radicals, radical-ions, carbanions and carbocations are all possible.
- No additional reagents are required for the reaction to proceed, the electrons are generated at the electrodes. Reagents used in organic synthesis can be expensive and will also create side products in the reaction.
- Precise control of the electrical current allows for control of the reaction.
- Electrochemical reactions can be carried out under mild conditions. The driving force of the reaction is the electrode potential rather than thermodynamic control.
- The process lends itself to continuous production because the reaction can continue as long as the electrical current is supplied.
- The cost of electricity remains fairly constant while chemical reagents will vary in price and availability.

There are of course some disadvantages to the process:

- Often a combination of solvent and supporting electrolyte has to be used to enable conductivity through the circuit.
- These supporting electrolytes can be expensive and add an aqueous work-up step to the experimental procedure.
- Cells usually have to be cooled to avoid the cell over heating from the synthesis.
- Part of the cell such as the separator membrane and electrodes may have a specific life span and will need to be replaced, sometimes at high cost.
- In-homogeneities of the electrical field.
- “hot-spots” and “dead zones” are apparent due to poor mass/heat transfers.

1.2. Industrial electrochemistry

Despite having commercial advantages there are still very few electroorganic syntheses that are commercially carried out. From the early 1900's industrial electrochemical processes were used for production of compounds such as benzidine, chloroform and hydroquinone to name a few, but many were discontinued. Benzidine for example was found to be a carcinogen and discontinued for this reason while tetraalkyl lead was found to be a pollutant and eventually removed from petrochemicals. Improved catalytic systems for both hydrogenation and oxidation became more feasible and other synthetic routes using different intermediates to those formed from electrochemical processes have all had a part in some industrial electrochemical processes being discontinued.⁸

Despite this there are two industrial processes that stand out for different reasons:

1. The “Monsanto” process for the production of adiponitrile **1**.¹¹
2. The paired electrosynthesis of phthalide **3** and *t*-butylbenzaldehyde dimethylacetal **4**.

1. The “Monsanto” process

The production of adiponitrile **1** by the electrohydrodimerisation of acrylonitrile (Scheme 1.3) was discovered by Baizer in 1960.¹¹ It is still the largest produced electrochemical product at around 200 million kg a year.⁸ The key to the success of the synthesis was the discovery of tetraalkylammonium salts increasing the yield of product to > 90%. The first stages of the industrial process were carried out in a divided cell, but soon after an undivided cell was created, it proved to be more successful and found to use less than half of the total current needed for the divided cell. The supporting electrolyte in the system is known as BisQat, a bis quaternary ammonium salt with two positive nitrogen centres and two anionic phosphate counterions.^{8,11,13} Success can also be attributed to the market in which the product is synthesised for, it is almost exclusively used to produce the precursor for nylon 6-6, hexamethylenediamine **2**.

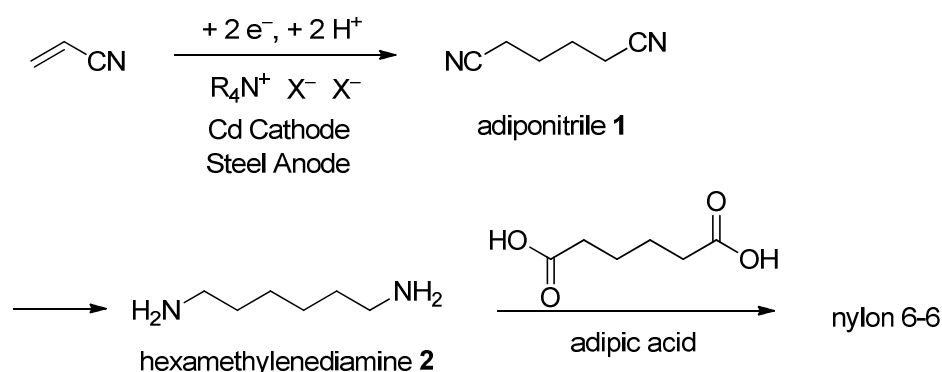
Scheme 1.3: Electrosynthesis of adiponitrile **1** and its transformation to nylon 6-62. BASF paired electrosynthesis of phthalide **3** and *t*-butylbenzaldehyde dimethylacetal **4**.

Up until 1998 both of these compounds were produced individually with the synthesis of phthalide **3** needing high pressure H_2 as a reagent. This is the first large scale industrial electrochemical paired synthesis that has been reported (Scheme 1.4). The process is used to produce over 4000 metric tons per year and has an overall yield of 90% for each product. The process is conducted in an undivided cell and an important factor is that methanol is being used as both the solvent and a reagent. The methanol is produced at the cathode from the reduction of the diester, to give

phthalide **3**, while being used at the anode for the production of *t*-butylbenzaldehyde dimethylacetal **4**. Protons are simultaneously generated at the anode and consumed at the cathode so no hydrogen gas is produced during the reaction.^{8,13,14}

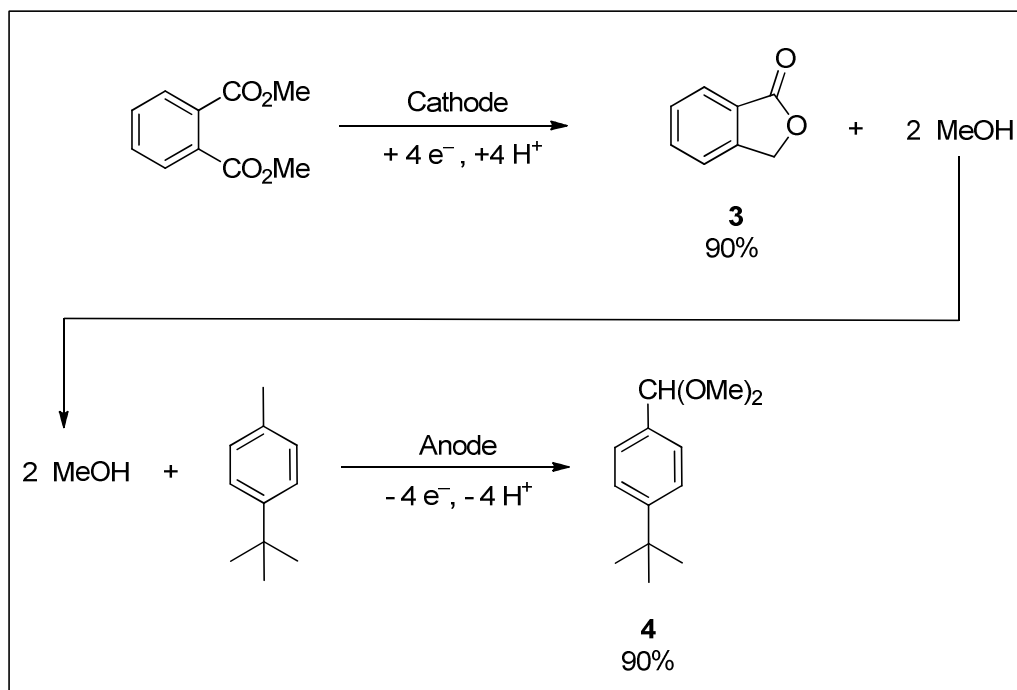

Scheme 1.4: BASF paired electrochemical synthesis of **3** and **4**

1.3. Fundamentals

To carry out electrochemical syntheses an electrical circuit is used which has been broken and replaced by two electrodes, the anode (positive) and the cathode (negative). The electrodes are submerged in an organic/aqueous solvent with a supporting electrolyte dissolved in it to assist in carrying the current through the cell (Figure 1.2). The two separate electrode processes occurring simultaneously allow for electrons to move through the solution. The substrate will either undergo oxidation at the anode, where electrons are removed from the substrate to the electrode, or reduced at the cathode, where electrons are transferred from the electrode to the substrate in solution, and this is the driving force to complete the circuit and carry out electrochemical synthesis. If the desired product is from oxidation at the anode, the anode is known as the “working” electrode, and the cathode will be the “auxiliary” or “counter” electrode.^{6,15}

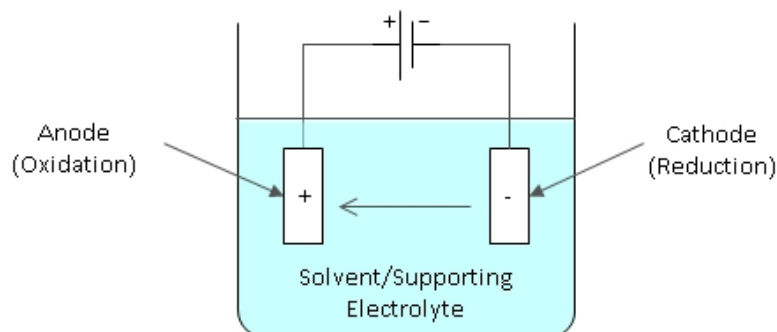

Figure 1.2: A simple electrolysis cell

As with conventional batch techniques, there are a number of variables in any electrochemical reaction that can be altered for process optimisation. Some variables are inevitably the same in both electrochemical and synthetic processes, such as temperature, reaction time and concentrations, but of course there are variables specific to electrochemistry and they are represented on the electrochemical reaction diagram below (Figure 1.3).

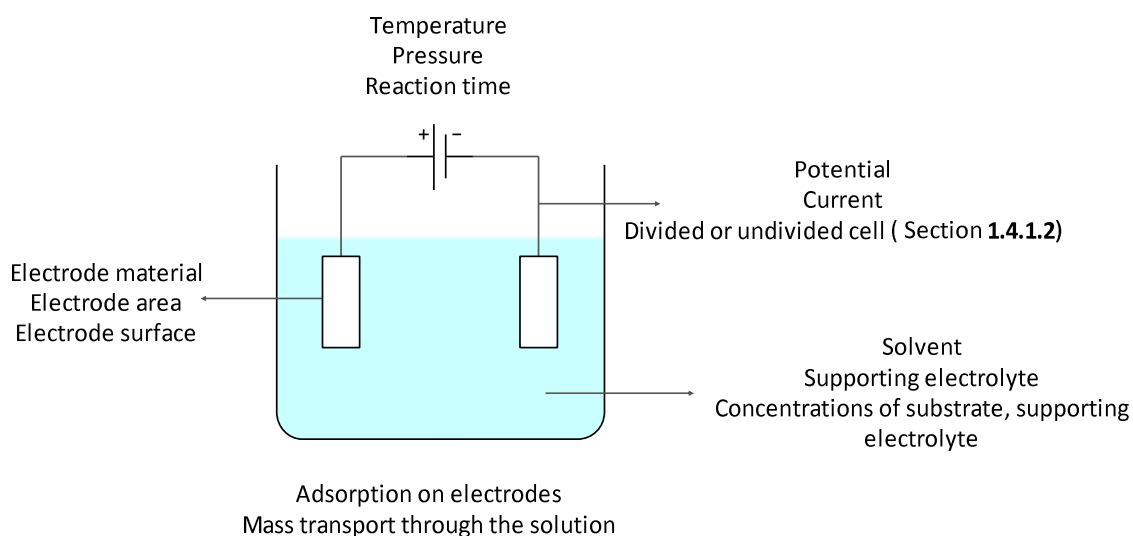
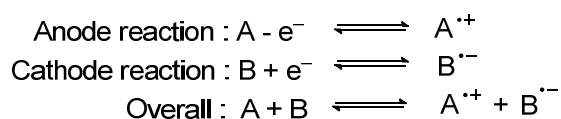

Figure 1.3: Variables of an electrochemical process

1.4. Electrode reactions

To describe the electrode reactions we can think of the substance being oxidised as an electron donor (A) to the electrode to give a radical cation, and the substance

being reduced as an electron acceptor (B) to give a radical anion. The two half equations can be written as follows:¹²



Both anodic and cathodic reactions are reversible until a chemical reaction takes place from the electrogenerated radicals. Almost all electrochemical syntheses are comprised of electrochemical and chemical steps to achieve the desired reaction products. These steps are simply denoted E for an electrochemical step and C for a chemical step to classify the various mechanisms possible.

The EC mechanism is the simplest form of electrochemical mechanism and can either be EC or CE.

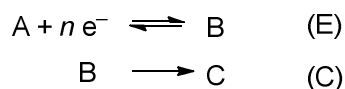

Mechanisms can also be more complex and reactions of this type include ECE, ECC and EEC and we can use the Kolbe electrolysis again to demonstrate an ECC mechanism.¹⁶ The first step is the oxidation at the electrode to leave a carboxyl radical, the electrochemical step. The two chemical steps that follow are the decarboxylation of the intermediate, and the dimerisation of the alkyl radicals to complete the synthesis.

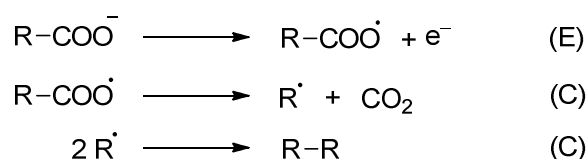

The electron transfer steps can be further characterised in certain cases, (E_r), (E_{qr}) and (E_i) for reversible, quasi-reversible and irreversible electron transfers. If the electron transfer occurs while in solution then it is termed solution electron transfer (SET) and this topic has been extensively reviewed by Evans.¹⁷ There are of course other types of reaction mechanisms that can take place and these have their own nomenclature to differentiate between them. If for example the electrochemical step is a disproportionation reaction then the reaction is termed (DISP). If the chemical

step is a dimerisation then it is termed (D). More complex reaction mechanisms with numerous electron transfer steps can be called “square”, “ladder”, “fence” or cubic. An example of a square mechanism is illustrated below in Figure 1.4 where the horizontal steps correspond to electron changes and the vertical steps involve proton transfer.^{6,12,16-17}

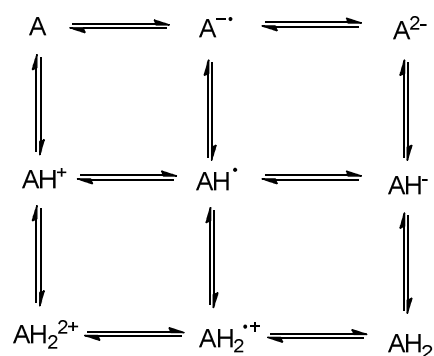

Figure 1.4: Square reaction mechanism of possible E steps¹²

1.5. Physical phenomena

1.5.1. The electrochemical double layer

It is important to realise that the electrochemical reaction taking place is at the electrode/solution interface and the solution is made up of several layers. There have been many adaptations of the theory of this interface since Helmholtz first put forward his theory of the double layer in 1879. If we take the cathode as an example, the negatively charged surface of the electrode attracts positive ions from solution to the electrode surface where they are bound tightly or “specifically adsorbed” to the electrode surface and this is known as the “compact” layer.

The “diffuse” layer comprises of ions that are solvated and they cannot be held as tightly to the electrode as the compact layer of ions because of the surrounding solvent molecules and are said to be “non-specifically adsorbed”. A diagram is shown below (Figure 1.5) that illustrates the double layer, it is a variation of the model put forth by Grahame in 1947,¹⁹ who was the first to adapt the theory to incorporate the diffuse layer to the model.

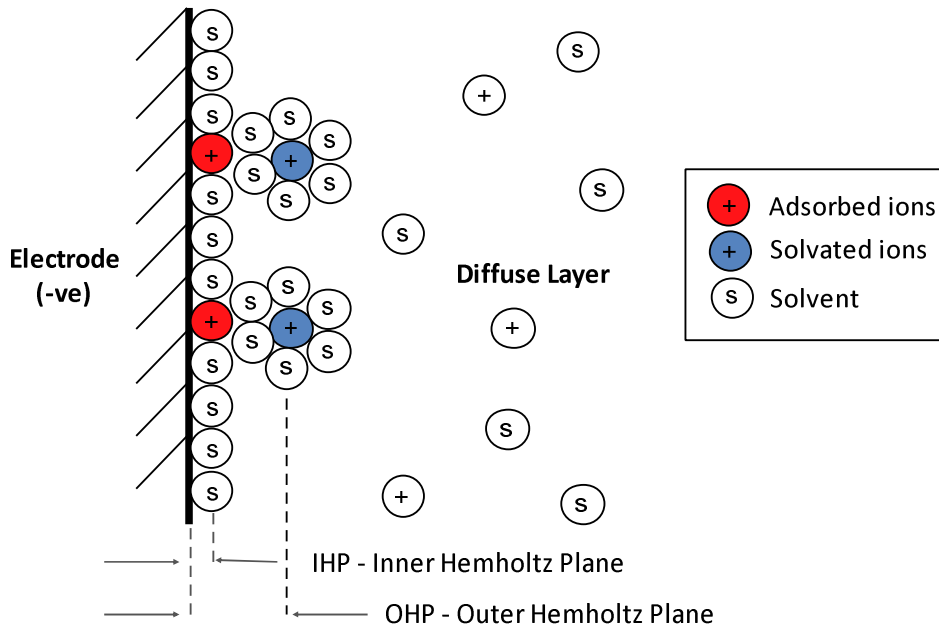

Figure 1.5: Proposed model of the electrochemical Double Layer²⁰

The distance from the centre of the ion bound to the electrode is known as the Inner Helmholtz Plane (IHP) and it was experimentally realised that the compact layer acted as a type of capacitor reducing the potential of the electrode as the distance from the electrode increases (Figure 1.6). The Outer Helmholtz Plane (OHP) is the distance from the centre of the solvated ion to the electrode surface. Due to the fact that they are solvated, it inherently means that they cannot get as close to the electrode as in the compact layer. The decrease in potential is a linear decrease up to the OHP and then decreases exponentially through the diffuse layer.^{6,12,18–24} A comprehensive review of this topic has been published by Parsons.²⁵

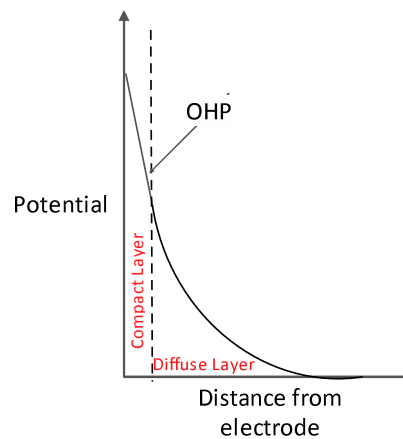

Figure 1.6: The potential drop of the electrode

1.5.2. Mass transport

The physical process of mass transport plays a pivotal role in the electrochemical process as the substrate that needs to undergo the electrochemical reaction is dispersed in a three-dimensional phase. It has to arrive at the electrode surface for a reaction to occur, and then leave the electrode into the bulk to form the products. Without this process only a few molecules that are on the electrode surface would undergo a reaction.

All electrode processes have to go through the same three steps to reach completion, the simplest comprises of:

- Mass transfer from the bulk solution to the electrode surface.
- Electron transfer at the electrode.
- Mass transfer from the electrode surface to the bulk.

There can of course be chemical steps before or after being adsorped and this is depicted in Figure 1.7.²⁶

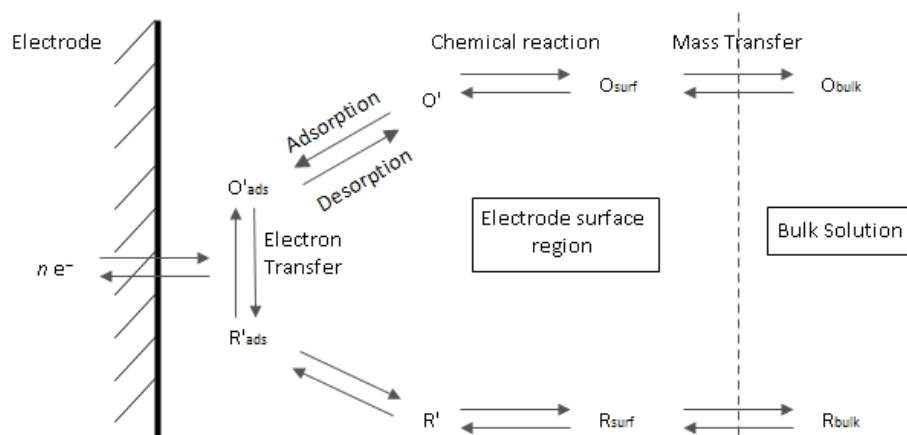

Figure 1.7: Electrochemical reaction steps (O = reactant, R = product)²⁶

There are 3 modes of mass transfer that can occur:

- Diffusion
- Migration
- Convection

1.5.2.1. Diffusion

Diffusion is the movement of ions in solution when no external force is applied. In the solution a concentration gradient is present because the concentration of ions is different throughout the solution. To keep equilibrium diffusion takes place. This is the movement of the ions from areas of high concentration to areas of low concentration (Figure 1.8 a).^{6,12,19,25-26}

1.5.2.2. Migration

Migration is the result of applying an external electrical force to the system. This causes charged particles in the solution to move between the anode and the cathode, in this case the gradient is as a result of the potential difference between the two electrodes. (Figure 1.8 b).^{6,12,19,25-26}

1.5.2.3. Convection

Convection is the displacement of particles in solution with the application of an external force, for example, stirring the reaction solution. Convection can also be due to natural effects, such as differences in densities caused by temperature and concentration. Forced convection is applied to cancel out the natural convection effects so a steady state can be achieved in the solution.^{6,12,19,25-26}

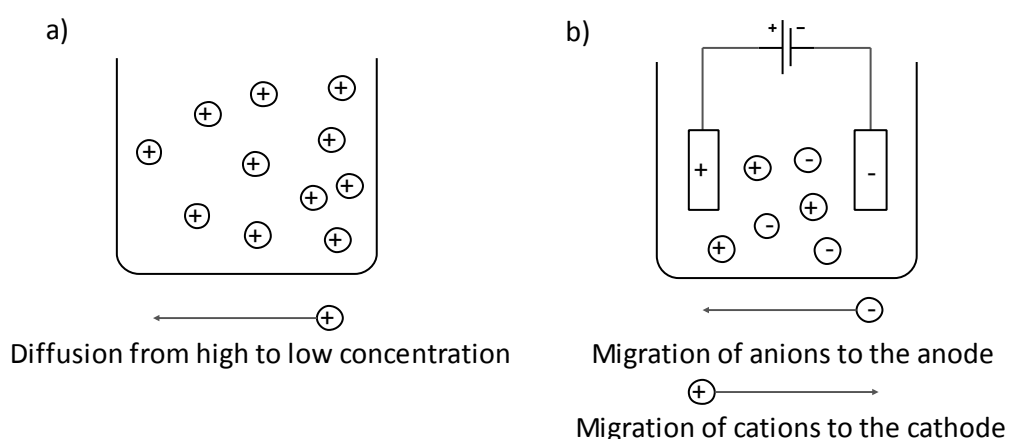
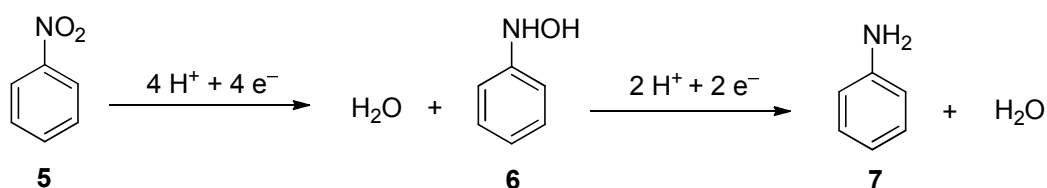

Figure 1.8: Illustrative examples of a) Diffusion, b) Migration

1.6. Methods of electrolysis

1.6.1. Controlled potential electrolysis

There are two methods in electrochemistry for controlling the amount of electricity being put into the reaction. The first to be discussed is the constant potential technique which was introduced by Fritz Haber in 1898. He discovered that nitrobenzene **5** could be selectively reduced to phenylhydroxylamine **6**, and at more negative potentials would be further reduced to aniline **7** (Scheme 1.5).^{18,28}



Scheme 1.5: Controlled potential electrolysis products of nitrobenzene

The main difference other than potential (E) being controlled and not current (I), is the necessity of a third electrode, known as the reference electrode (Figure 1.9). The current is passed through the working and auxiliary electrodes, while the reference electrode is currentless. The working electrode's potential is kept constant relative to this, although in certain cases this third electrode can be neglected.

This technique has the advantage of being highly selective when compared to controlled current electrolysis because the potential of the electrode can be adjusted to the required oxidation/reduction potential for the desired reaction of the substrate to occur. This means that if the substrate, once reduced, has the ability to be reduced a second time at a more negative potential, this reaction cannot occur. The same is valid for molecules with two functional groups that can both react. The potential can be set accurately and only the desired reaction will occur.^{6,12,14,25}

In Figure 1.10 an illustrative potential/current curve is shown for a two step reduction. Between (A) and (C) a one electron reduction is taking place while the potential is set at E_1 . At E_1 the first reduction can take place and all molecules that come into contact with the electrode will become reduced. If the potential is made more negative, E_2 , the second reduction can take place. The potential of the

electrodes can be set to either E_1 or E_2 and only one of the reactions can occur, hence the reaction is selective.

However the disadvantage of this technique is that the reaction time can be very long. The current is never higher than the limiting current that corresponds to the electrode reaction, (Figure 1.10, I_l) and because the current is proportional to the substrate concentration it means that as the substrate is consumed, towards the end of the electrolysis, the current is very low and the rate of the reaction slows down.^{12,18}

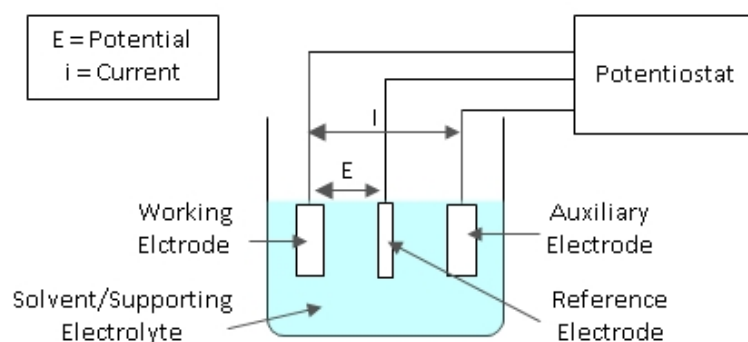

Figure 1.9: Schematic representation of a 3 electrode cell for controlled potential electrolysis

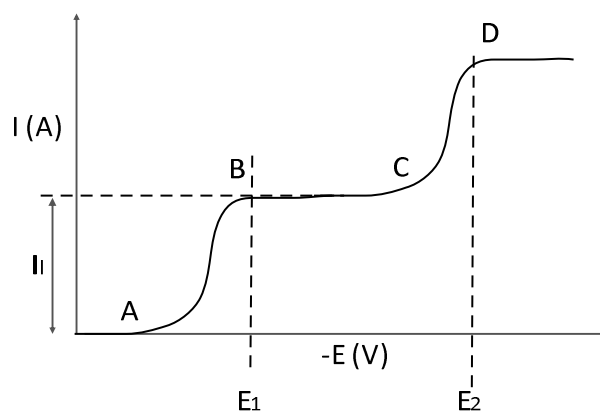

Figure 1.10: A current Vs. Potential illustration of a constant potential 2 step reduction

1.6.2. Controlled current electrolysis

When controlled current techniques are being used, the current is held at a constant value while the potential of the electrodes is allowed to vary to keep the current constant. The instruments needed for this technique are simpler than with controlled

potential electrochemistry because there is no feedback from the reference electrode to the potentiostat, it is simply a working electrode, auxiliary electrode and a power supply such as shown in Figure 1.2. This is one of the reasons as to why constant current techniques were the most widely studied in the early years of electrochemistry, because the equipment needed was less sophisticated.

Once the current for the reaction is applied, the potential of the cathode will decrease until it reaches a potential sufficient to reduce the species with the most positive potential. During electrolysis the concentration of the substrate and its limiting current diminishes. Once the limiting current is below that of the applied current the cathode potential will then have reached the reduction potential of the second species. Until each reactive species or the solvent has been oxidised, the potential will continue to become more negative, this is why the selectivity of the technique can cause problems. However if there are no other reactive species present in the reaction solution other than that of the desired species, more than a 90% conversion of the starting material can be achieved.^{6,12,14,25}

In the example shown in Figure 1.11, if the applied current is I_a , the electrode assumes the potential where the first reduction takes place, (E_1 , curve 1) when I_a is lower than both the limiting current for the first species, I_{l1} , and the potential required for the second reduction. As the reactive species is consumed during the reaction and the concentration decreases, so does the limiting current I_{l2} , which is now lower than I_a , the electrode potential has now reached E_2 , where the second reduction can take place.^{12,18}

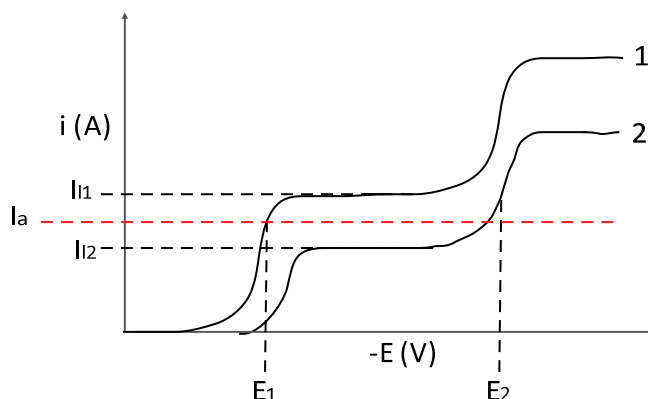

Figure 1.11: A current Vs. Potential illustration for a constant current 2 step reduction

Another appealing aspect of controlled current electrolysis is the ease at which the amount of electricity needed to complete the reaction can be calculated. Faraday postulated as early as 1834 that the charge passed (Q) through the circuit is proportional to the number of electrons consumed during the reaction:

$$\text{Faraday's Law: } Q = n(e^-) \times F$$

Where Q = Charge (coulombs), F = Faraday constant ($96485.336 \text{ C mol}^{-1}$), n = number of electrons.

So the amount of electricity to be passed through the circuit can be calculated from:

$$\text{Amount of electricity (F mol}^{-1}\text{)} = I \times t / F \times m$$

Where I = Current (Amps), t = time (seconds), m = the number of moles of substrate.

This also allows for the current efficiency to be calculated, which is important for industrial processes, using the equation:

$$\text{Current efficiency} = m(\text{product}) \times (n(e^-) \times F) / I \times t$$

Both of these techniques can not only be used for electrolysis but there are many techniques for both controlled potential and current such as linear and cyclic voltammetry, coulometry and chronopotentiometry.

1.7. Cell design

1.7.1. Batch cells

Electrochemical cell design can be a complicated procedure depending on the type of electrolysis wanted to be carried out. Considerations include:

- Divided/Undivided
- Electrode materials
- Reference electrode
- Diaphragms
- Cell material
- Gas inlets/outlets
- Stirred solution
- Temperature control

Some of these points will be discussed further.

1.7.1.1. Undivided cells

The most basic type of cell construction is that of an undivided cell for constant current electrolysis, comprising of an unsealed glass beaker and two electrodes with a stirrer bar if needed. Undivided cells are generally used for reactions where the products formed during the reaction will not react with the other electrode. An example of such a reaction is the Kolbe electrolysis. The electrodes are placed as close to each other as possible to reduce the resistance of the cell and more electrodes can be set in parallel to produce a larger working electrode surface. Even if a more complex electrolysis system is required, this type can be easily realised with a commercially available vessel as shown in Figure 1.12 that allows for a sealed reaction where the reaction be carried out under vacuum, reflux and allows for the introduction of gases to produce an inert environment or for the removal of gases formed during the reaction.^{6,12,29}



Figure 1.12: A simple undivided cell for electrolysis

1.7.1.2. Divided Cells

When thinking of cells for controlled potential electrolysis and analytical techniques, much more complicated cell designs have been realised. They are mostly of the H-Cell type of design (Figure 1.13), and the glassware needed for such an experiment is much more complex in comparison to that needed for an undivided cell. In a divided cell, the solutions contained in either the anodic or cathodic chambers are separated by a diaphragm or membrane. This can be either to keep both the solutions separate during electrolysis, or allow ions to diffuse through to the other chamber. This type of cell is much more efficient at keeping the reaction selective due to the divided nature of the cell.^{6,12,29}

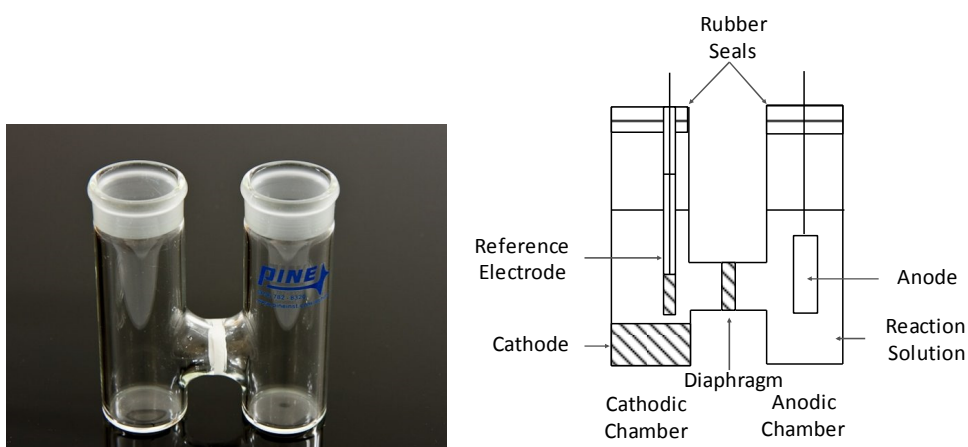

Figure 1.13: A photograph and schematic diagram of a common H-Cell

1.7.2. Flow through cells

In principle it can be easy to convert a batch electrolysis cell into a flow electrolysis cell by adding an external loop to allow for the reaction solution to be pumped through the cell from a large reservoir of solution. Flow cells of both divided and undivided types have been realised and have been used in industry for many years producing chemicals on a large scale. The production of adiponitrile **1** by BASF, is performed in a “capillary gap cell”³⁰ continuously, which consists of a stack of bipolar electrodes (acting as the anode for one cell and the cathode in another) separated by non-conducting spacers. One issue with the cell is the life-time of the electrodes rarely exceeds a few months.^{8,11}

This topic, organic electrochemistry in flow, is to be the main area of discussion for this thesis, although on a micro-scale with volumes and electrode distances being in the micrometer range, which as an area of chemistry has grown massively over the past 10-20 years. Microflow cells, or microreactors used for electroorganic chemistry will be reviewed in more detail in Section 3 of the general introduction and throughout the remainder of the thesis.

1.7.3. Electrode materials

The material used for electrodes can also have a great impact on the outcome of the reaction. An extensive review on electrode materials and effects on reactions has been published by Pletcher.³¹ Factors that need to be considered include:

1. Physical stability of the electrode - the electrode must be structurally strong enough so that it is not damaged during the building of the cell whether it is a solid, wire or gauze type of electrode.
2. Chemical stability - the electrode material should be chemically inert to the solvent, substrates, and intermediates formed during the reaction.
3. Electrical conductivity - it is essential for the electrode to have good electrical conductivity for current to pass through the circuit.
4. Rate and product selectivity - both of these factors can be affected by the electrode material as is illustrated below (Scheme 1.6).

5. Cost/durability - it is obviously advantageous to the environment and to industry that the electrode material has a good life-time without needing to be replaced.
6. Anode/cathode materials vary for different reactions, mostly due to corrosive factors that are present during anodic reactions makes the choice of anode material much more limited for this not to be a factor.

Typical materials for the anode that meet these criteria are the noble metals such as platinum or gold, carbon anodes are also a popular choice and can be in different forms such as graphite or glassy carbon. Other anode materials include lead, lead oxide or nickel.

There are many more materials available for the cathode due to the fact that corrosive effects are less apparent, mercury was one of the early cathode materials used, often employed as a dropping mercury electrode (DME) although the use of mercury is diminishing over time due to its toxic nature. Other materials include lead, tin, copper platinum nickel or carbon among others.^{6,12,31,32}

There are many other types of electrodes other than solid metal electrodes as already described.^{6,12,32}

- Sacrificial electrodes can be used as either anodes or cathodes, and as the name suggests they are consumed during the electrolysis for incorporation into the desired product.
- Porous electrodes can be used in order to increase the working surface area of the electrode.
- Coated electrodes can be used to lower the cost of electrodes. For example a platinum coated titanium or carbon electrode will inherently be cheaper than a solid platinum electrode.
- Gas evolving electrodes. Often O_2 , H_2 or CO_2 can be evolved at electrode surfaces and these bubbles can improve mass transfer to the electrode surface.
- Gas diffusion electrodes have a major use in fuel cells. The lower solubility of the reactants e.g. O_2 or H_2 is increased by using a three dimensional electrode and diffusion of the electroactive species.²¹

- Rotating disc electrodes can also be used, the main purpose for this is to suppress the natural convection forces present in the reaction system.

As mentioned earlier the electrode material can affect the mechanism and products. Again here we can use the Kolbe electrolysis as an example of this (Scheme 1.6). A platinum anode gives, the “Kolbe dimer”, obtained through an alkyl radical formed as the intermediate. For graphite electrodes the carbocation is the intermediate formed, leading to different products from reaction with a nucleophilic solvent such as acetonitrile or methanol, and again on lead oxide electrodes a completely different product is formed because the route of adsorption/desorption and electron transfers work differently with the different electrode materials. The intermediates possible during electrolysis will be discussed later in section 1.10 of the general introduction.^{6,12,22}

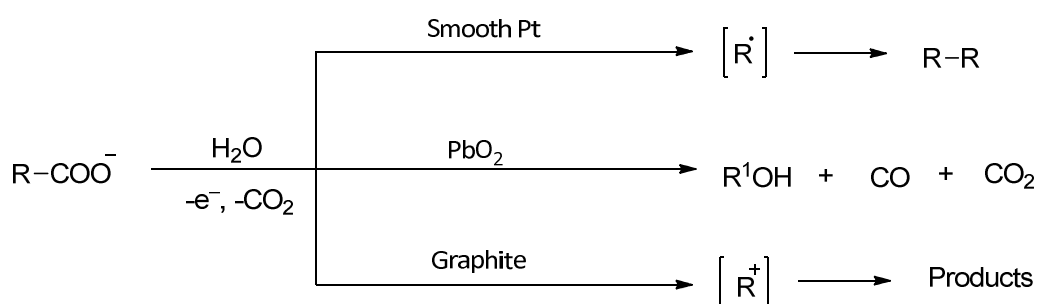

Scheme 1.6: Different possible products with different electrode materials⁶

1.7.4. Reference electrodes

The reference electrode is of utmost importance when it comes to controlled potential electrolysis or analytical techniques. The main criteria for a reference electrode is to have a known potential to within 1 mV, and for the potential to change very little during reactions. The most common type of reference electrode used is the saturated calomel electrode (SCE). The electrode itself comprises of a mercury electrode in contact with a paste of Hg_2Cl_2 in a central tube in the overall electrode. This is then surrounded by a saturated solution of KCl in the outer compartment of the electrode. The potential is then determined by the concentration of an anion, Cl^- , that forms an insoluble salt with the metal cation Hg^+ and the value

for the potential of the SCE electrode is known to be +0.242 V. However due to toxicity problems with mercury, these electrodes are becoming less popular and others such as Ag/AgCl reference electrode are being used as their replacements.^{6,12,22,29}

1.7.5. Diaphragms

When carrying out controlled potential electrolysis in a divided cell, a necessary component of the cell is the diaphragm, to keep both the anodic and cathodic solutions separate so the product formed by either the anodic or cathodic reaction cannot react with the other electrode. The diaphragm needs to stop either the solvent, products or substrates from travelling through the cell. Also it cannot impede the electricity passing through the cell and it must be physically and chemically robust. Either glass or ceramic frits with sufficient porosity are ideal for this purpose.

Ion exchange membranes primarily do the same job as the diaphragms, keeping the two cell departments separate. They can be made to be either cationic, anionic, amphoteric or bipolar membranes. Typically cation exchange membranes are used, and they are of particular use when the products of electrolysis are of opposite charge to that of the working electrode. This means they cannot leave the working electrode chamber and remain there as the desired products.^{6,12,29}

1.8. Solvent Effects

In organic chemistry the solvents can have dramatic effects on the outcome of reactions. Properties such as temperature range, viscosity, toxicity, volatility and price are factors that apply to both organic and electroorganic chemistry.

Electrochemistry requires the solvent to have additional properties that are essential for reactions to proceed smoothly and efficiently. Such as:^{6,12,21,27,33}

- The ability to dissolve both organic substrates and inorganic salts. Few solvents possess this ability, for example water can dissolve many inorganic salts easily but lacks the ability to dissolve many organic substrates. This can be overcome by a solvent mixture, acetonitrile or methanol mixed with water. Tetraalkylammonium salts however are soluble in most polar solvents as well as some non-polar solvents such as dichloromethane or acetonitrile.

- Solvent dielectric constants are preferred to be high. This is an important factor in electrochemistry as it affects the resistance of the solution between the electrodes. If the dielectric constant is high, then the salt is usually fully dissociated in the solution making the resistance of the solution low. The values for many solvents can be found in organic electrochemistry text books.
- Proton activity, the availability of protons, is an important factor in electrochemistry. Anodic reactions are less affected by proton activity than reductions but stability of intermediates is affected. If proton activity is high during a reduction, the protonation of the substrate may occur before the electrochemical step, this makes the substrate more easy to reduce. The lifetimes of intermediates in aprotic media for example anions, are much longer than in protic media.
- The usable potential range of the solvent should be such that the solvent itself will not react at the electrodes. During anodic oxidation for example, only few polar solvents are resistant to anodic oxidation.
- The ability to solvate ions. It is important that salts are dissociated in solution, the ions are then free to move through the solution between the electrodes to carry charge lowering the cell resistance.

Solvents can be divided into two groups:

1.8.1. Protic solvents

Protic solvents are those which have protons bound to a heteroatom such as acids, alcohols and water, or aqueous mixtures of an organic solvent and water. Many electrochemical experiments have been carried out in water throughout the history of electrochemistry. It has a high dielectric constant and a good ability to dissolve supporting electrolytes, and can be mixed with organic solvents to increase the dissolving capability towards organic substrates. But it is also an attractive solvent due to its lack of toxicity, cost and availability.^{6,12,20,21}

An example of an acid as a solvent can be sulfuric acid which can be either used in dilute or a concentrated form. It is able to dissolve many organic substrates and is a good electrical conductor due to its dissociation. This means that no supporting

electrolyte is required to carry electrical charge through the cell. It does of course, have disadvantages, along with the possibility that it could protonate or sulfonate substrates, and its high boiling point makes the work-up procedure more difficult.^{6,12,20,21}

Methanol is a good solvent for anodic oxidations such as the Kolbe electrolysis, methoxylations are also an appealing aspect to using methanol as a solvent. During electrolysis methoxide anions are produced at the cathode and can then act as a nucleophile in the reaction. Methanol also has a high good dielectric constant and is efficient at dissolving both organic substrates and inorganic salts. Methanol also having a low boiling point making the work-up a simplified procedure.^{6,12,20,21}

1.8.2. Aprotic solvents

As with protic solvents, aprotic solvents can also be used as aqueous or anhydrous solvents. The purpose for first using anhydrous aprotic media for electrolysis was to simplify the electrode processes during the reaction. The lack of protons in the reaction means that anionic intermediates have a much longer lifetime in the reaction and less side reactions are possible. The lack of protons in the reaction also allows for other reactants in solution to be able to act as electrophiles towards the intermediates. Anhydrous aprotic media also allowed for a wider range of useable potentials compared to that of the corresponding aqueous solvents.^{12,33,34}

Acetonitrile is one of the most widely used solvents in electrochemistry and can be applied to both oxidation and reduction reactions. It is miscible with water and is a good solvent for many organic substrates and inorganic salts and has a polar character arising from the nitrile group. It also has a high dielectric constant and it is not easily oxidised or reduced during electrolysis making the useable potential ranges for both anodic and cathodic reductions wide.^{12,22}

Other aprotic media commonly used in electrochemistry are solvents such as dimethylformamide (DMF) or dimethyl sulfoxide (DMSO).

1.9 Supporting Electrolytes

As already briefly discussed, one of the most important factors to consider in choosing a supporting electrolyte for electrochemistry is its solubility in the desired

solvent. It is also advantageous for complete dissociation of the salt with a high mobility of ions in solution. The salt must also be inert to electrode reactions in the working potential range of the experiment. The electrolytes, are divided into two groups, anionic and cationic.

1.9.1 Anionic

Anion selection becomes most important when undertaking anodic reactions. The anion needs to be unable to react in the potential range of the reaction. Salts such as perchlorates and tetrafluoroborates have a high discharge potential (the potential at which the ion will react with the electrode), making them attractive for anodic oxidations because they will not be oxidised before the substrate. Perchlorates have a tendency to explode during the work-up procedures when the organic solvent is removed. Tetrafluoroborates are a more attractive option even though the tetrafluoroborates ion has a slightly more positive discharge potential than that of perchlorate. Other anionic salts include nitrates and trifluoromethanesulfonates.^{6,12,21,32}

1.9.2. Cationic

As with anionic salts, the choice of cation becomes more important when considering cathodic reactions, with the limiting factor being the discharge potential of the cation, it cannot be discharged before the desired reaction. Alkali and alkali earth metal salts are good inorganic salts that can be used, however it is the tetraalkylammonium salts that have received the most attention in organic electrochemistry. The cationic part is usually either tetraethylammonium or tetrabutylammonium with a greater selection of the anion, tetrafluoroborates, perchlorates and the halides are typical variations of the salts. A paper comparing tetraalkylammonium salts published by House *et al.*³⁵ concludes that tetrabutylammonium perchlorate has ideal properties, and its commercial availability means it is advantageous for most preparative electrolytic reductions.^{6,12,21,32}

1.10 Electrochemical intermediates and reactions

In electroorganic synthesis, the intermediates formed are frequently the same as those intermediates that are found in conventional organic synthesis. Scheme 1.7 shows how these intermediates are formed, and the reactions that radicals can undergo once formed. Starting with an alkyl halide it can be seen that the first steps, being electrochemical are reversible to attain either the corresponding radical anions or cations, these radical ions can then undergo cleavage of the halide bond to leave uncharged radicals.^{6,9,17}

These radicals can then either take part in electrochemical reactions (ECE) leading to either the alkyl cation or anion which can then take part in further reactions, or in chemical steps (ECC) with the formation of a variety of products possible which will depend on solvents, electrolytes and conditions of electrolysis, with the most common reaction being the radical dimerisation (Kolbe electrolysis).

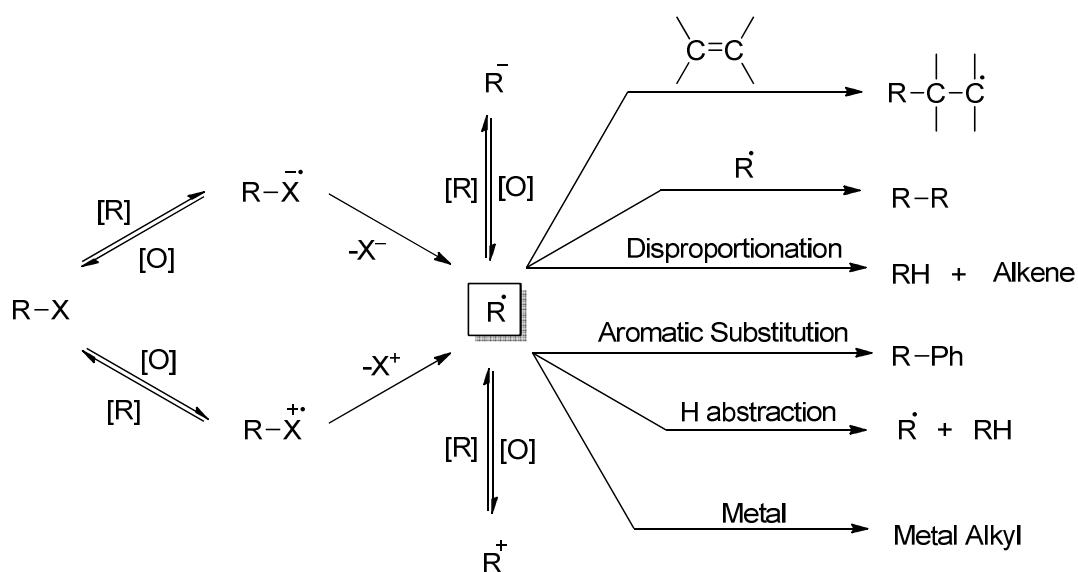

Scheme 1.7: Electrochemical intermediates and radical reactions

Electrochemical reactions can be divided into two sections, direct and indirect, the former utilising intermediates formed directly at the electrodes, while in the latter the electrodes are used to generate, and regenerate reagents.

1.10.1 Direct intermediate formation

It is also convenient to divide direct electrochemical reactions into carbon-carbon bond forming reactions, and functional group interconversions.

1.10.1.1 Carbon-carbon bond formation

Carbon-carbon bond formation in electrochemistry can be either polar or radical in nature, as well as pericyclic and transition metal-catalysed reactions being possible.

1.10.1.1.1 Polar/Umpolung reactions

In polar carbon-carbon bond forming reactions, electron donors and acceptors are electrochemically generated by oxidation or reduction of nucleophiles and electrophiles. These reactions are umpolung reactions, where the polarity of the functional groups is reversed, this allows for a unique aspect of electrochemistry to be utilised, where either two electron donors, or two electron acceptors can be coupled intramolecularly (Scheme 1.8).³⁶

At the cathode, an electrophile can be converted to an electron-donating radical anion by the reduction of the substrate (Scheme 1.8 a), while oxidation at the anode will lead to a nucleophile being transformed into an electron-accepting radical cation (Scheme 1.8 b) allowing for efficient cyclisation when the two groups in question can react intramolecularly. For the same processes to be achieved in traditional synthetic chemistry at least two chemical steps are needed highlighting that electrochemistry can be advantageous over well-known chemical techniques. This has been applied for cyclisations of molecules containing a large variety of functional groups including aryls (Scheme 1.8 c),³⁷ nitriles and esters.^{6,9,12,36}

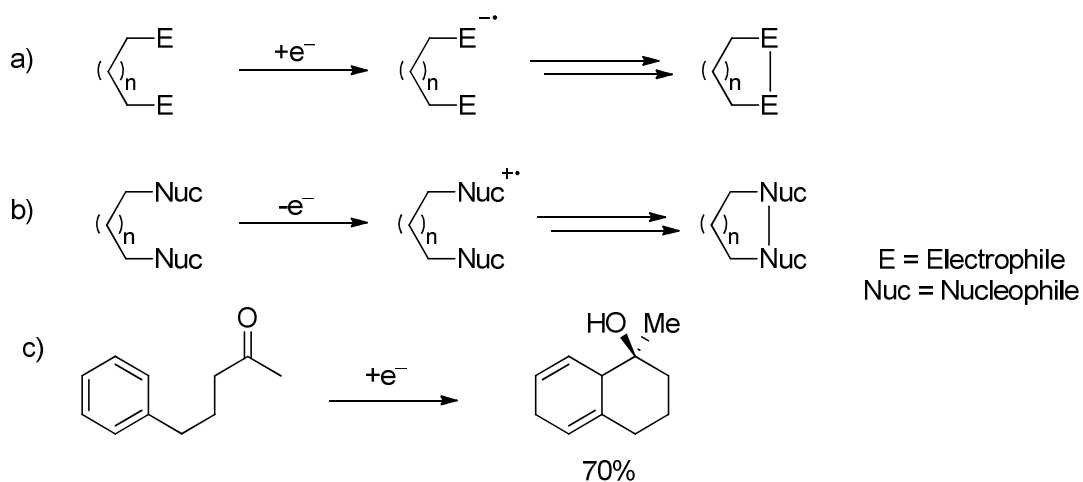
Scheme 1.8: Polar reactions in electrochemistry³⁶

Anodic coupling reactions can also take part in polar dimerisation reactions by two possible mechanisms through a radical cationic intermediate **8**. If an aromatic hydrocarbon is used as an example, the first mechanism (Scheme 1.9 a) is the reaction of the cation radical with the neutral substrate to give a diphenyl product. In the second mechanism, the radical cation is deprotonated to a radical, followed by oxidation leading to a cationic intermediate which can take part in electrophilic aromatic substitution to give a diphenylmethane product (Scheme 1.9 b).^{12,38,39}

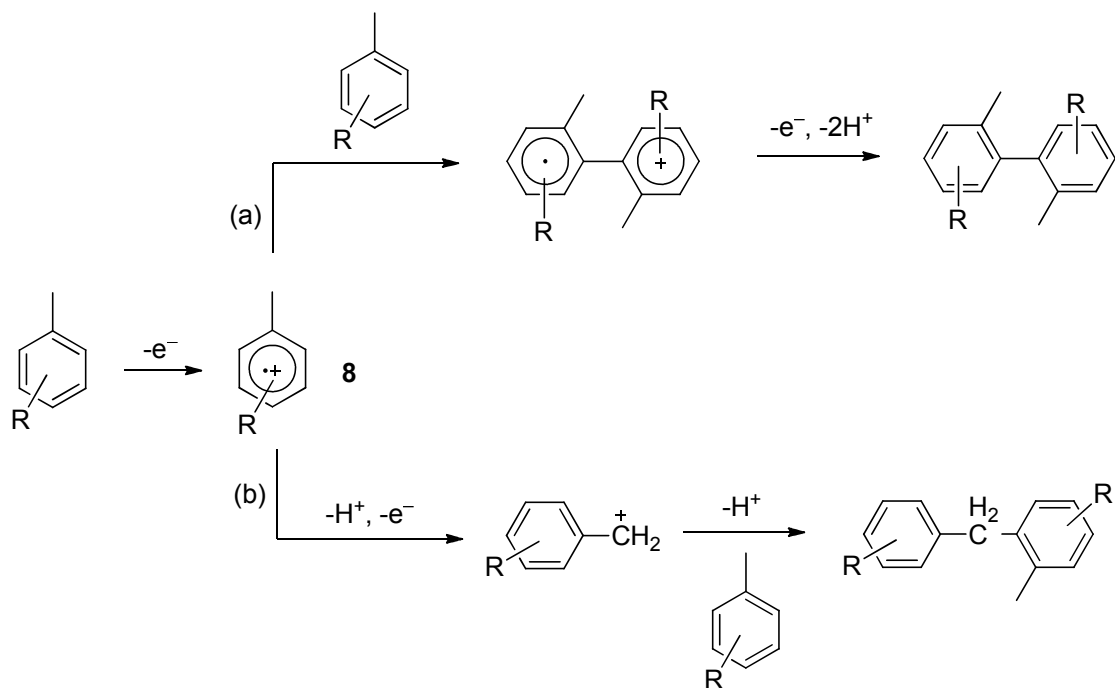
Scheme 1.9: Anodic polar coupling reaction^{12,38}

Cathodic reactions can also be used for carbon-carbon bond formation in the form of electrohydrodimerisation (EHD). This is the reaction of electron deficient alkenes which once reduced at the cathode, will give an anionic radical intermediate **9** (Scheme 1.3, Scheme 1.10 a). The Monsanto process for the production of adiponitrile **1** is an industrially important example of electrohydrodimerisation.⁴⁰ There have also been two other mechanisms shown to be possibilities of routes to dimerisation for the anionic radical (Scheme 1.10 b & c). Route b follows Michael addition of the radical to the initial substrate which can result in hydrocyclisation, and route c has been proposed for the radical dimerisation of dimethyl maleate.^{6,12,38}

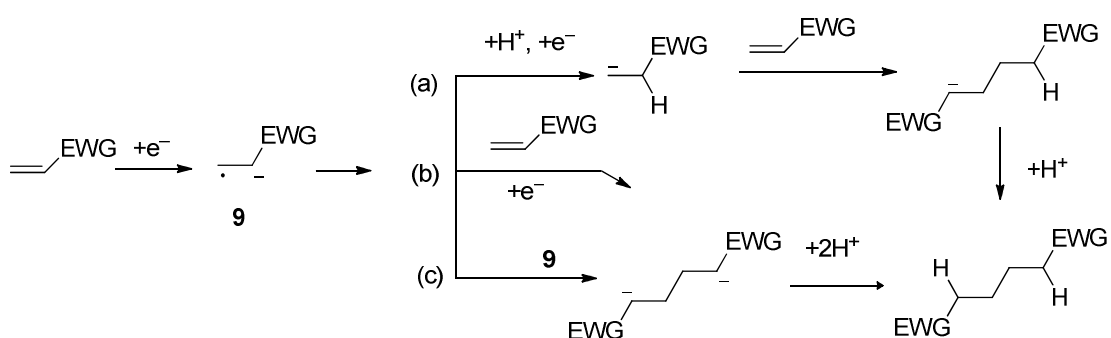

Scheme 1.10: Cathodic polar coupling reactions^{12,38}

1.10.1.1.2 Radical carbon-carbon bond formation

If we consider radical reactions for carbon-carbon bond formation, it can be seen from scheme 1.7 that radicals can be easily generated by electrochemical methods. For anodic examples we can once again use the Kolbe electrolysis as an example (Scheme 1.2). The decarboxylation of a carboxyl radical yields an alkyl radical which will then dimerise.

Radical addition to alkenes is another method of creating carbon-carbon bonds. The radical formed by oxidation of an alkyl anion or by reduction of an alkyl cation will add to the carbon-carbon double bond giving a radical intermediate **10** which itself can then either dimerise, react with another radical of the substrate, or with a nucleophile (Scheme 1.11).^{6,12,36} This type of reaction will be discussed in more detail in Chapter 5 with specific examples concerning the radical addition of trifluoromethyl radicals to C-C double bonds.^{6,9,12,17,38,41}

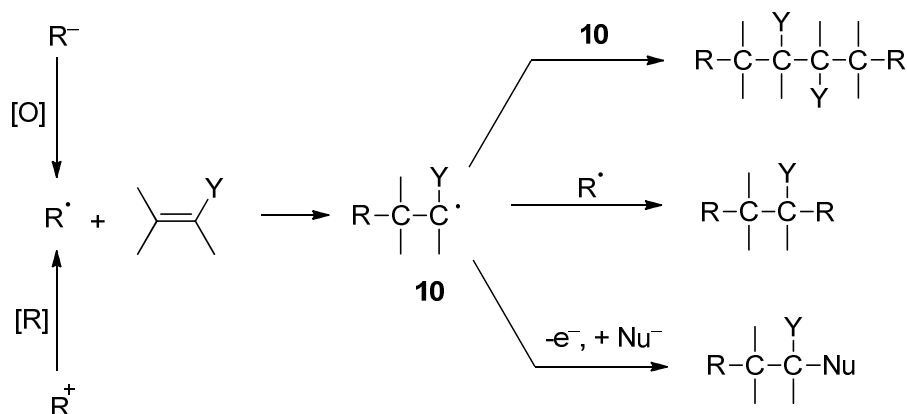
Scheme 1.11: Radical carbon-carbon bond forming reactions^{6,12,36}

1.10.1.2 Functional group interconversion

In organic synthesis there is a large variety of methods available to convert functional groups in molecules selectively with numerous reagents that are commercially available although some can be expensive. In electrochemistry, functional group interconversions can be classified into four categories (Scheme 1.12).^{6,12}

1. Anodic substitution/cathodic cleavage.^{6,12,39,41,42}

Anodic substitution can work for both activated and unactivated C-H bonds. The C-H bond is oxidised to a cation radical, followed by substitution and a follow up oxidation to give a cation which reacts with a nucleophile. Electrochemical anodic substitution of aromatic compounds has a clear advantage to that of batch chemical reactions because nucleophiles such as -OR and CN can be introduced in one step.

At the cathode the reaction is generally replacing a C-Nu bond, where Nu can be a halide, NR_3 , or PR_3 activating the C-Nu bond. The reaction proceeds via an electron transfer from the cathode leading to an anionic radical, which dissociates to give Nu^- and a radical. After a subsequent reduction this radical can be protonated giving the C-H bond.

2. Anodic dehydrogenation/cathodic hydrogenation

For the anodic dehydrogenation of alcohols to ketones, or amines to nitriles there are many methods of achieving this electrochemically with a wide variety of electrode

materials, both directly and indirectly. The electron transfer is followed by deprotonation to give the product.

At the cathode hydrogenation can be achieved by the addition of an electron and a proton. Electrochemically this has the advantage of being able to selectively hydrogenolyse either carbon heteroatom bonds or carbon-carbon double bonds. Chemically, catalytic hydrogenation or the use of metal hydrides is needed to achieve the same result.

3. Anodic addition/cathodic elimination^{6,12,39,41,42}

In anodic addition reactions, two nucleophiles can be added to a carbon-carbon double bond in one step. Examples such as the methoxylation of furan to give 1,4-dimethoxyfuran is of industrial interest.

At the cathode reductive elimination is able to remove a variety of vicinal nucleophiles/leaving groups forming double bonds. The leaving groups can be Br^- , OAc^- , NO_2^- and electrochemically a chemoselective elimination can be achieved.

4. Anodic cleavage/C-C bond formation (EHD)^{39,42}

Anodic cleavage can be applied to a variety of bonds including C-C, C-O, C-S, C-halogen bond amongst others. The electrochemical oxidation is followed by a chemical reaction resulting in the bond cleavage.

Cathodic C-C bond formation has been previously discussed in section **1.7.1.1.1** where EHD is discussed.

Other electrochemical conversions are possible, such as the conversion of heteroatoms to different oxidation states. Groups including -S-, -SO-, NO_2 and NH_2 , molecules can also be selectively deprotected during constant potential electrolysis making it a valuable alternative to chemical deprotection in certain cases.^{6,12,39,42}

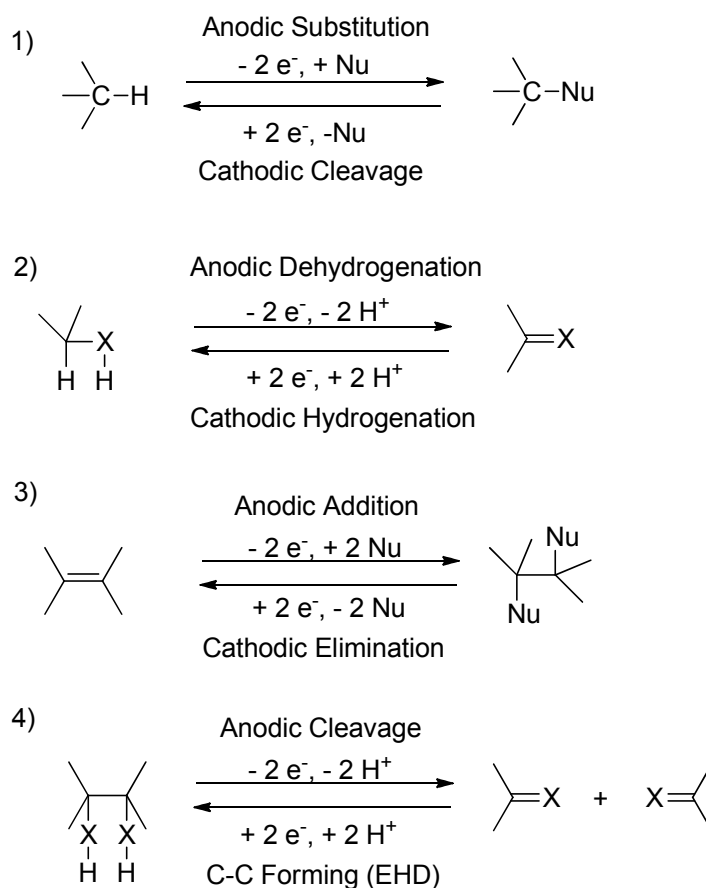
Scheme 1.12: Possible electrochemical functional group interconversions^{6,12}

1.10.2 Indirect electrochemistry

Indirect electrolysis widens the possibilities of electrochemistry. The substance being oxidised or reduced is not the substrate, it is a redox catalyst (or mediator in its activated form). The first step is the heterogeneous electron transfer reaction with the electrode, followed by a homogeneous electron transfer with the substrate. Once reacted with the substrate, the mediator is regenerated and will again react at the electrode. The use of redox catalysts is beneficial, not only because less than stoichiometric amounts are needed. Sometimes catalytic amounts are possible. They can also increase the working potential of the electrodes and prevent inhibition of the heterogeneous electron transfer step that can occur in direct electrolysis due to surface oxide layers being formed, the adsorption of intermediates on the electrode or other ions in solution.⁴³

The redox catalysts should possess certain properties to make them suitable for reactions:

- They should be chemically stable in both forms omitting side reactions, and not reacting with solvents in the system.
- Electron transfer steps between the electrode and substrate should be fast and reversible if possible.
- They must have sufficient solubility in the solvent system.

Indirect electrolysis can be carried out both *in-situ* and *ex-situ*, but also the mediator can remain fixed at the electrode surface being regenerated continuously.^{6,38,39,43}

In Scheme 1.13 the indirect oxidation of an alcohol induced by TEMPO **11** (2,2,6,6-tetramethylpiperidine-*N*-oxyl) is shown. Compound **11** is converted at the anode into TEMPO⁺ **12**, which is selective towards primary alcohols. Once the substrate is oxidised, **12** is reduced to the hydroxylamine which comproportionates with **11** to regenerate **11** so the cycle can continue.^{41,43,44}

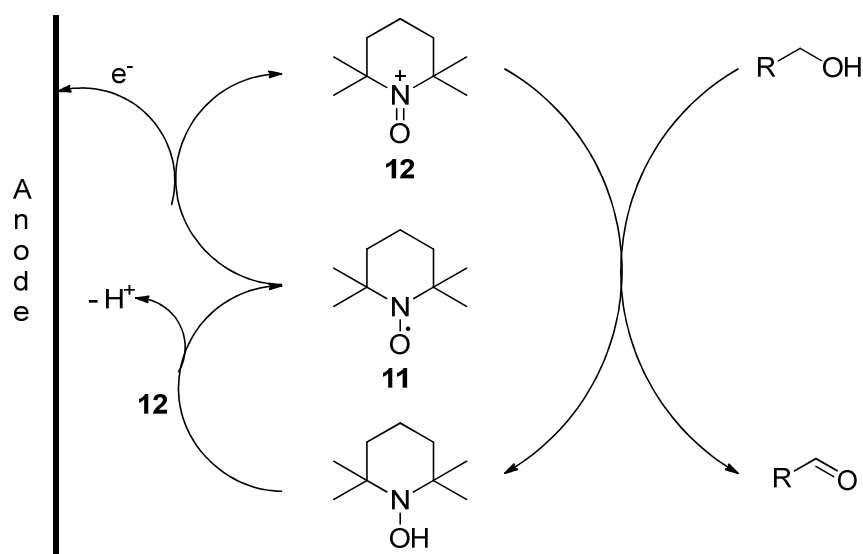

Scheme 1.13: Indirect oxidation of primary alcohols with TEMPO as a redox catalyst.^{41,43}

More specific examples of electrochemical synthesis will be shown and discussed in Section 3 of this general introduction, where syntheses carried out in electrochemical microreactors are discussed.

2. Microreactors for organic synthesis

2.1 Introduction to flow chemistry

The term “micro” is related to the volumes and dimensions of the reactors and substrates, typically within the micrometer range, usually if the dimensions are larger than 300 μm then the term “meso” is more appropriate.

The term “flow” is simply relating to the fact that the processes are continuous, reaction mixtures are pushed through the system, usually by some pumping device (hydrodynamic flow, section 2.5).

Over the last 10 to 20 years interest in the field of microreactors and continuous flow chemistry has increased steadily due to continuing attempts to make chemistry “greener” in all fields. The platform that microreactors offer is perfect for this aim, miniaturising traditional flask chemistry, reducing amounts of solvents, substrates and making process optimisation a much less wasteful process. Another factor in the increase of the amount of chemistry being carried out today in microreactors is the commercial availability of chip reactors and modular devices. Its expansion through chemistry is evident within areas like medicinal chemistry, with PET (positron emission tomography) tracers being synthesised in microreactors,⁴⁵ and in the fine chemical and pharmaceutical industries.⁴⁶

There are many reviews on the subject of microreactors, comparisons to batch chemistry and syntheses carried out in microreactors so this section is not an exhaustive review but to demonstrate advantages of flow chemistry in microreactors and examples of reactor setups for carrying out different chemical reactions.

2.2 Microreactor set-up

Setting up a system for flow chemistry can be as simple as using a T-piece to introduce the two reagents into a micromixer⁴⁷ connected to tubing, commonly PEEK (polyether ether ketone) which act as inlets and a reactor coil, of known length and volume. The syringe pump contains the reactants in syringes and forces them through the system. The coil can be placed either in a heating bath or ice bath, or left at room temperature. The tubing can be cut to any length desired, combined with the speed of the syringe pump to calculate the required residence time for the

synthesis (Figure 1.14). Commercially available modules, such as the “Vapourtec” system shown in Figure 1.15 are also available. It is a computer controlled module where reaction conditions are programmed, and numerous reactions can be run automatically, in sequence, at high temperatures or pressures. Residence times are specifically controlled by the HPLC pumps and products can be collected in an optional autosampler ready for work-up or the next step in the reaction sequence. This type of device demonstrates well the advantages of continuous flow processing in microreactors .

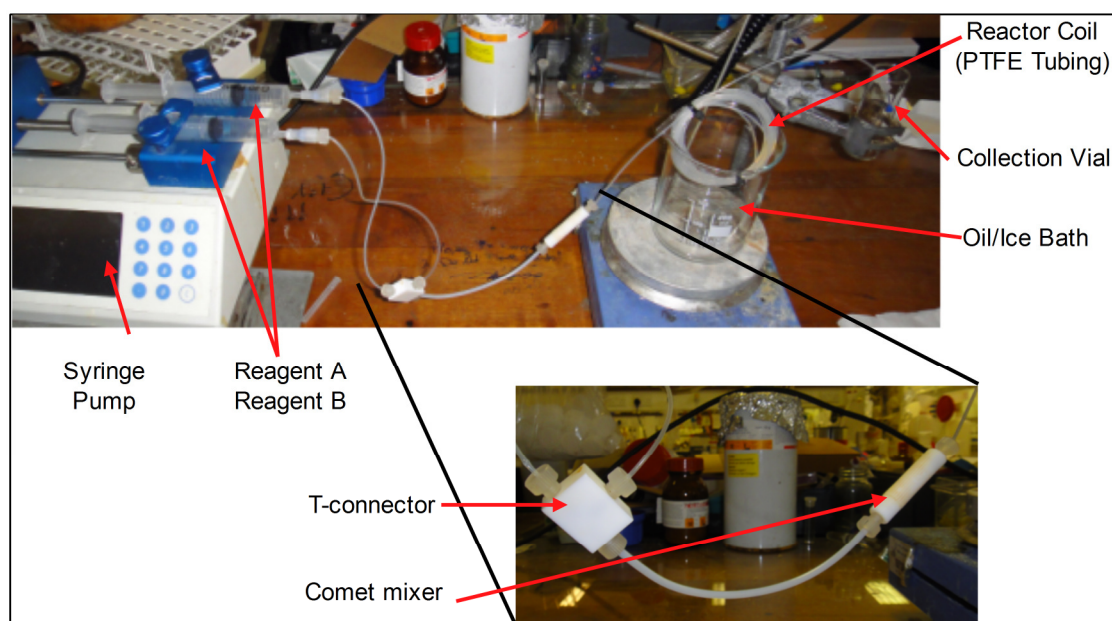

Figure 1.14: A basic microreactor set-up suitable for organic synthesis

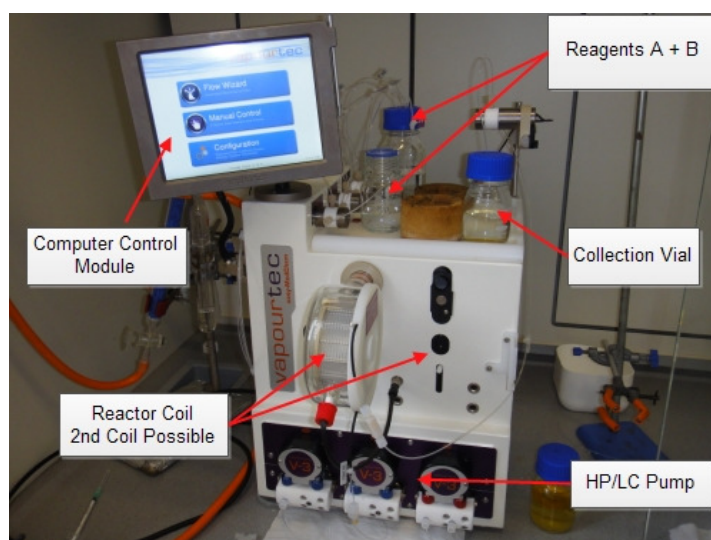

Figure 1.15: A commercially available computer controlled “Vapourtec” system

2.3 Chip/reactor design

The design and fabrication of microreactors is primarily undertaken as an engineering challenge. Today the amount of reactors described is almost “unlimited”, in the sense that they are being produced for specific reactions meeting specific requirements for the synthesis being carried out, so only a few aspects of this topic are discussed here.

The technology for creating chip devices has advanced so much that it is now possible for research groups to use three dimensional printing tools for creating their own specific reactors, designed with reagent inlets and channel lengths that are required for a specified reaction.⁴⁸

There is a wide range of materials available for the fabrication of microreactors, leaving the decision having to be made on the specific requirements of the synthesis. Some factors that have to be considered are:^{49–52}

- Temperature ranges
- Pressure ranges
- Resistance to chemicals and solvents
- Durability
- Micro channels within the device

If metal is the material of choice, techniques like etching, precision machining with micro drills, and metal forming can be applied to achieve the result. If for example extremely high temperatures are required, materials like ceramics can be utilised with a temperature range of up to and over 1000 °C.⁴⁹

Microreactors constructed from silicon or glass are frequently used in organic synthesis, created by etching techniques such as photolithography, wet/dry chemical etching and photostructuring.⁴⁹ A wide variety of microreactors are now commercially available and can be purchased for individual needs. Variable volumes, extra inlets for sequential reactions or quenching and chips containing catalyst beds are some examples. In Figure 1.16 examples of Chemtrix BV chips that our research group have used for organic synthesis are shown.

Image a) shows a chip with two inlet ports for the initial reagents followed by the reaction channel, then the third reactant is introduced before the last reaction channel takes the products to the collection vial. This chip is used for 2 step syntheses. Chips with more inlets can be made/purchased for multistep syntheses, although a tubing set-up with micromixers placed after each reaction coil can be used to achieve the same result.

Image b) shows a chip with 2 inlets and a reaction channel followed by a catalyst bed to be packed with the required catalyst before leaving to the collection vial.

Image c) is the chip holder to connect the chip to the reagent streams and collection vial.

The chips are photographed next to a 1 pence coin to put their small dimensions into perspective.

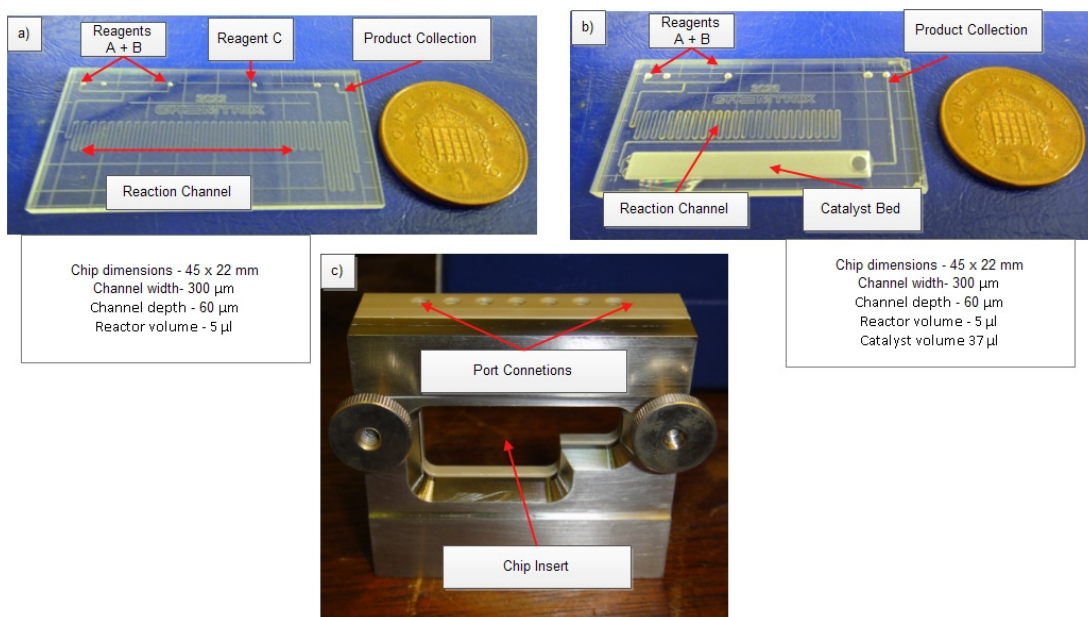

Figure 1.16: Examples of commercially available silicon chip reactors

2.4 Advantages of flow chemistry

There are certain advantages of flow chemistry that are difficult to recreate in a batch chemistry environment, such as:

- Efficient mixing of reagents.^{53,54,55}
- Efficient heat management.^{56,57}

- High surface to volume ratios.⁵⁸
- Integrated reactions.^{59,60}
- Scaling up requires only more reactors in parallel or continuous processing.^{61,63}
- Specific residence time control.⁶⁴
- Online analysis.^{65,66}
- Handling of dangerous reagents/intermediates.^{67,68,69}
- Automated process optimisation.^{65,70,71}
- Reduced overall costs (consumption of reagents/solvents)

As with any relatively new technology there are drawbacks to flow chemistry, one of which is the inability to carry out reactions unless all reactants, reagents, intermediates and products are all in solution during the reaction sequence to prevent reactor clogging. This limits certain reactions that can be carried out, although now such chips that include a catalyst bed are commercially available (Figure 1.16), similarly reactions can be run in multiphase systems to overcome such problems. One method that answers this problem was reported by Sedelmeier *et al.*⁷² for the oxidation of alcohols and aldehydes to carboxylic acids, and nitroalkane derivatives to the corresponding carbonyls and carboxylic acids using potassium permanganate. As the reaction proceeded a slurry of MnO₂ was found to cause clogging of the T-piece. To overcome this the T-piece and a section of reactor coil was submerged in an ultrasonic bath to allow the reaction to proceed efficiently. Other factors such as viscous solvents and back pressure created in the system can cause problems.

2.4.1 Efficient Mixing

The effects of micromixing are important factors contributing the advantages that can be gained from microreactor syntheses. In conventional batch chemistry the mixing is carried out by a magnetic stirrer bar in the flask. The part of the solution where the stirrer is in the flask, is under a much greater force compared to the areas of the flask that are at the furthest point away where the solution can be motionless. When the reaction is exothermic, “hot spots” in the solution appear due to the poor heat transfer in the solution from inefficient mixing. For fast reactions this can lead

to low yields or poor selectivity because the solution will not have reached homogeneity before the reaction proceeds.^{51,59}

This is overcome with the use of micromixers. Their small volumes and internal structure allows rapid and complete mixing within microseconds making them extremely beneficial for reactions with very fast kinetics as the solution is homogeneous almost as soon as the two reagents are combined. Micromixers can be split into two categories, passive and active. Passive mixers rely on external pumping forces for the solution but only diffusion or advection (the transport of a substance within a moving fluid), are responsible for mixing, while active micromixers have external forces generating a disturbance for mixing, such as pressure, temperature and electrokinetics. Comprehensive reviews^{53,54} have been written on this subject so only the fundamental process and a few examples will be given.

The simplest form of a micromixer is a simple T or Y shaped connector (Figure 1.17 a) where two reagents are combined from separate reagent streams. A big advantage of these types of mixers is their price compared to more complex designs, however once the reagent streams are brought together, mixing relies on diffusion of the two species through the solution interface, meaning a longer reaction channel is desirable for good results. Many different micromixers have been designed to overcome this problem and Figure 1.17 b shows a silicon chip reactor with an etched mixer design built in directly after the reagent streams combine. This allows the solution to become homogenous in a shorter time scale compared to that of the T-shaped design.⁵³

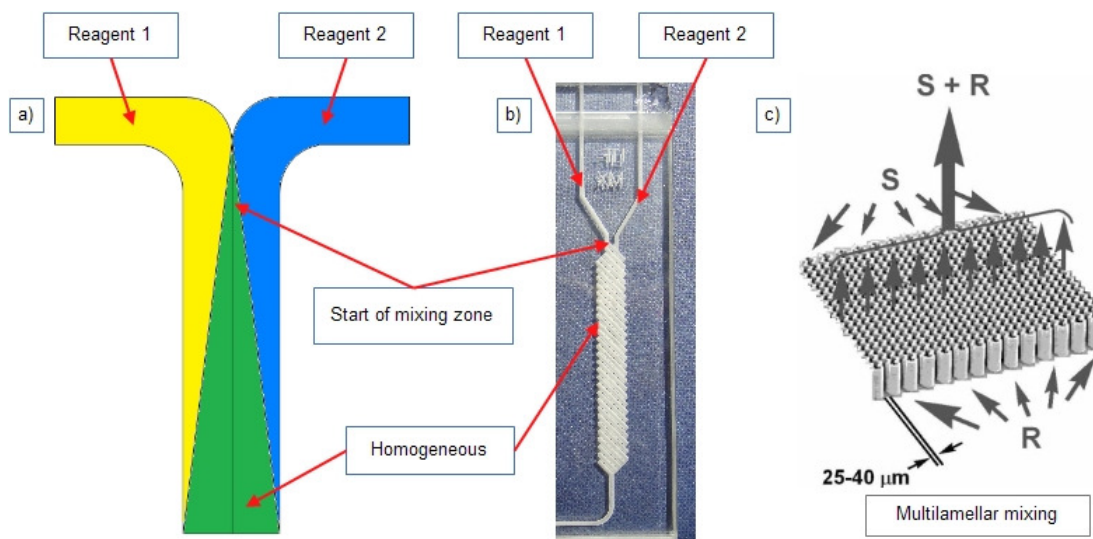
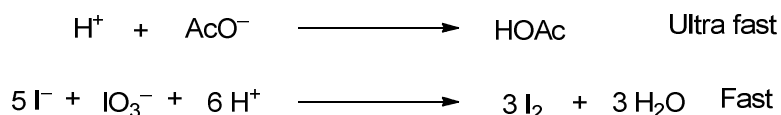

Figure 1.17: a) T-shaped micromixer, b) etched silicon chip mixer, c) multilamellar mixer⁷³

As already mentioned, the deciding factor for mixing when a passive T-mixer is used is diffusion, to illustrate the importance of this a comparison with a batch reaction in a calorimeter vial has been discussed.⁵⁵ The authors report calculated values for the diffusion of a molecule from the centre of the batch vial to the edge, versus that of a microreactor channel. The results are quite conclusive highlighting the advantage of a microscale device, 22.5 seconds for the microreactor compared to more than 27 hours for the batch reaction.⁵⁵

As an example of micromixers increasing chemical selectivities the reaction of HCl with Γ^- , IO_3^- , and NaOAc can be examined (Scheme 1.14). There are two competing reactions, the ultra fast reaction of H^+ with AcO^- , and the slower reaction of H^+ with Γ^- and IO_3^- (The formation of I_2). The authors compare a multilamellar micromixer (Figure 1.17 c),⁷³ where the reagent streams are divided into a number of separate streams and then combined, with a T-shaped micromixer and a batch reactor. Using UV detection it is possible to identify the formation of I_2 during the reaction. Their results show that the multilaminar mixer leads to selective formation of AcOH, with the T-shaped mixer and batch reaction both showing significant UV absorption relating to the formation of I_2 due to the imperfect mixing from these devices.^{73,74}

Scheme 1.14: Competing reactions avoided with the use of a micromixer^{73,74}

2.4.2 Heat management

Heat management is an important factor in chemistry, reaction rates can usually be increased with an increase in temperature but this can also lead to the formation of unwanted side products. Removing heat from a reaction is important with exothermic reactions, and can be difficult to achieve when scaling up reactions. High surface-to-volume ratios present in microreactors play an important part in this because the rate of heat transfer is directly proportional to the heat-transferring surface area making the ability to exchange heat orders of magnitude better than can be achieved in a batch vessel.⁷⁵ The material of the microreactor also plays an important role in heat management with thermal conduction through the reactor wall. To demonstrate this, an estimated temperature profile for an exothermic lithation reaction is shown comparing the heat dissipation of different microreactor materials (Figure 1.18).⁷⁶ It can be seen that Teflon is not a good material for conducting exothermic reactions as no heat is dissipated. With silicon and stainless steel it can be seen that after experiencing the exothermal heat from the reaction it is quickly dissipated.

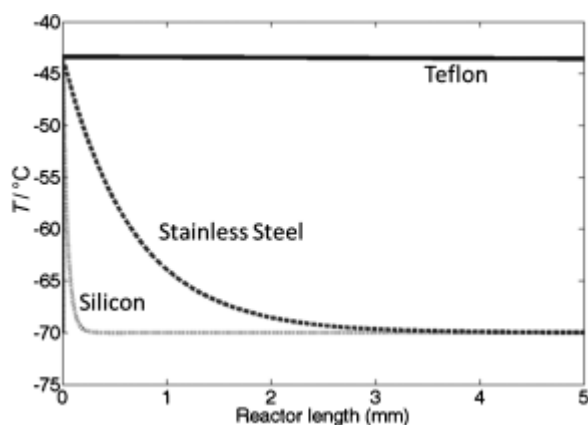

Figure 1.18: An estimated temperature profile for microreactor material and heat management

The formation of side products during a reaction can be explained by Figure 1.19.⁵⁶ On the left we have a normal distribution of molecules in a reaction, and although the reaction is set at one temperature in batch, a large temperature gradient is present. In contrast to the temperature distribution for a microreactor being a lot closer to that of an ideal reaction. If the image is superimposed on a potential energy diagram, the microreactor, having a smaller temperature gradient, only allows the formation of the desired product, whereas in the batch reaction, the large temperature gradient and higher potential energy causes the formation of a side product and loss of product is apparent.^{56,77}

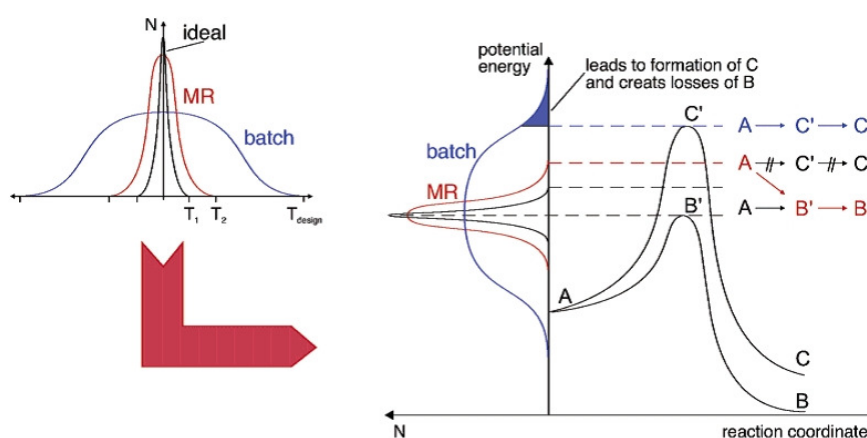

Figure 1.19: Thermal gradient and potential energy diagrams comparing batch and microreactor syntheses⁵⁶

This effective heat management in microreactors allows for highly exothermic reactions to be carried out. Nitration of aromatics is an important reaction in industry and also a highly exothermic reaction, if carried out in batch without sufficient heat management it can cause the temperature to increase uncontrollably and also create unwanted side products. The nitration of toluene has been studied in both batch and microreactors and the authors showed that the reaction rates were orders of magnitude higher in a microreactor while also eliminating the possible temperature “runaway” and the formation of side products, highlighting the benefits of microreactor technology for heat management.⁵⁷

4.3 Specific control of residence times

Specific residence times can be easily achieved in a flow system. The pumping devices can be set to achieve any flow rate required for specific reactions and the residence time can be calculated from the equation:

$$\text{Residence time (min)} = \text{Reactor volume (ml)} / \text{Flow rate (ml min}^{-1}\text{)}$$

In a batch reaction, completion can take anything from minutes to days. If the reaction is completed in seconds it can be difficult to work with in a flask. With microreactors, sub-second reactions are easily achieved and controlled. Yoshida *et al.* have shown that flash chemistry based on high-resolution time control could be achieved.⁶⁴ Their studies on the Swern-Moffat oxidation (Scheme 1.15) is used as an example to show the advantages in reaction times that be achieved.

The Swern-Moffat Oxidation is a mild and selective method for the transformation of primary and secondary alcohols into aldehydes and ketones. The reaction is run at low temperatures in a flask because the intermediates formed during the reaction are unstable above -50 °C. The authors showed that as long as the residence times were shorter than the lifetime of the intermediate, they could be reacted subsequently.⁶⁴

A typical batch reaction would be run at -70 °C giving yields up to 88%. When the reaction temperature was increased to -20 °C the yield and selectivity dropped dramatically from 83% to 19% cyclohexanone and side products of more than 70%. In their flow system, when the reaction was conducted at -20 °C with a residence time of 2.4 seconds, the yield was higher than that achieved in batch. Another interesting point is that when the reaction temperatures in flow were increased to 0 °C and 20 °C the yields and selectivities were very similar to that achieved at -20 °C in flow, and for -70 °C in batch, however the residence time could be reduced from 2.4 to 0.01 seconds.⁶⁴

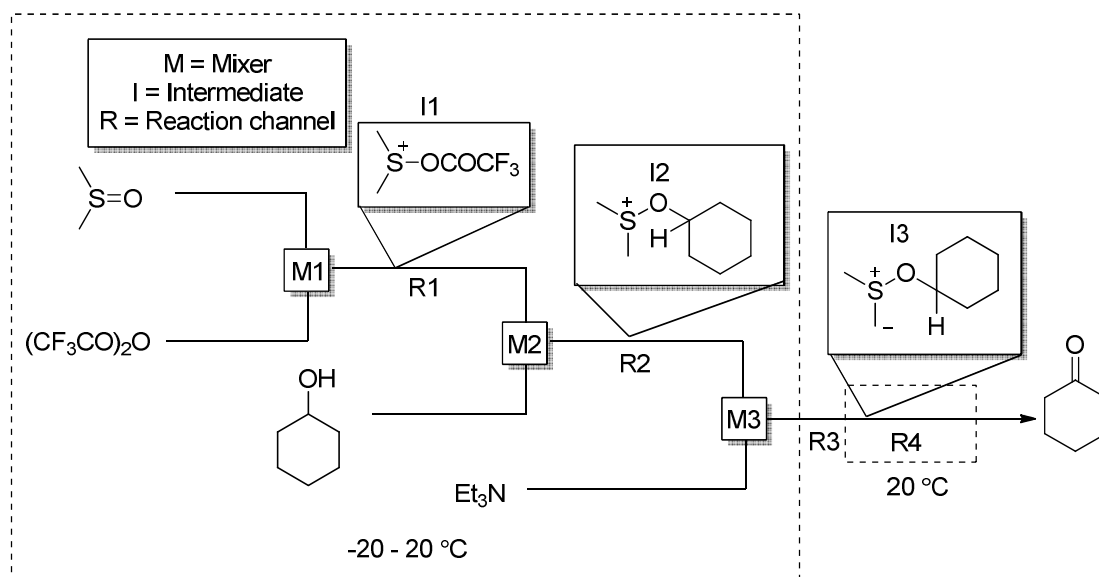

Scheme 1.15: A microreactor set-up for the Swern-Moffat Oxidation

2.4.4 Handling dangerous compounds

Their small dimensions and volumes make microreactors the perfect platform for using dangerous reactants, reactions with dangerous intermediates, and very strongly acidic conditions. We can look at two different examples from the Wirth research group to demonstrate how microreactors can be beneficial.

The first example uses concentrated acids as solvents for the Ritter reaction to synthesise amides.⁶⁹ The reagents are dissolved in acetic acid in the first reagent stream, while concentrated sulfuric acid is in the other. Reactions were heated to 90 °C in some cases making the reaction solution very dangerous if carried out in a flask. Yields achieved were up to 80% with residence times between 2 to 10 minutes depending on substrates used.

Iodine azide is a solid compound both toxic and explosive, a dangerous compound to be handled in a batch chemistry environment. Wirth *et al.*⁶⁷ have shown that it is possible to form iodine azide *in situ*, from tetrabutylammonium azide and iodine monochloride, in a microreactor and subsequently react it with aldehydes for the formation of carbamoyl azides (Scheme 1.16).

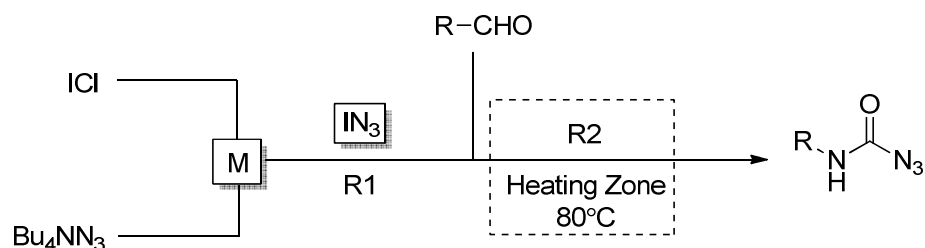

Scheme 1.16: A microreactor synthesis for carbamoyl azides via dangerous intermediates

2.4.5 Multistep synthesis

As it can be seen from some of the examples given so far in section 2 of this introduction, multistep reactions in flow are quite common occurrences. Being able to connect multiple reactor coils in series is simple to achieve. Commercially available chips as seen in Figure 1.16 are also available with multiple substrate inlets. The results can be significant when compared to a batch reaction, where it can be difficult to run subsequent steps in the same flask without prior isolation of the products.

An important reaction to mention here is the three step synthesis of ibuprofen in flow reported by McQuade *et al.*⁷⁸ (Scheme 1.17) The total synthesis comprising of a Friedel-Crafts acylation in the first step, followed by a 1,2-aryl migration and the final step being saponification to give ibuprofen in a 68% yield and a total throughput of 9 mg min⁻¹.⁷⁹

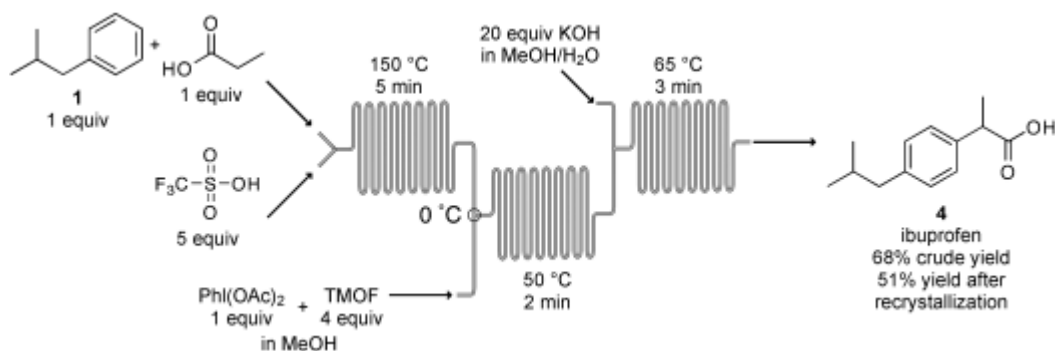

Scheme 1.17: The continuous flow synthesis of ibuprofen⁷⁸

2.4.6 Online analysis and self-optimising techniques

An advantage to synthesis that is only achievable in flow systems is the ability to analyse products with detection equipment built in to the system. Microreactor flow systems have also been developed to include software or digital cameras to monitor reactions and optimise them with no further assistance from the chemist.

The first example of on chip online analysis was reported by Belder *et al.*⁶⁶ for testing the enantioselectivity of enzymes (Figure 1.20). Reagents are fed into the chip and move through the chip by either the application of pressure or an electric field. The products are then guided into the separation channel by applying a voltage controlled pinch technique, and the desired electrophoretic separation is induced by applying an electrical field into the separation channel. The separated products are then analysed by a deep-UV laser.^{61,66}

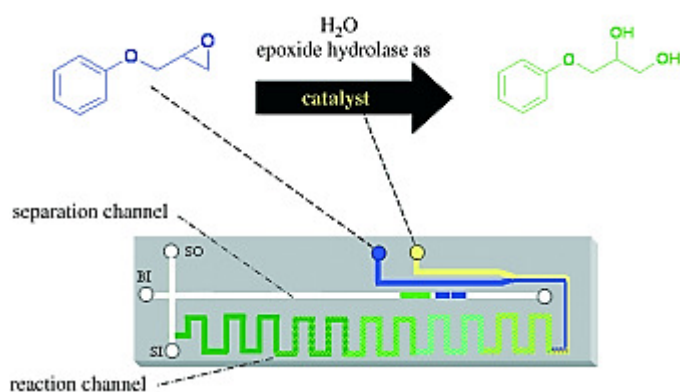
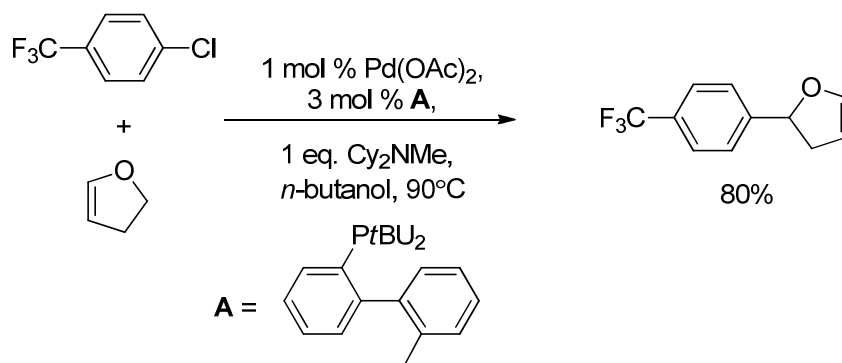
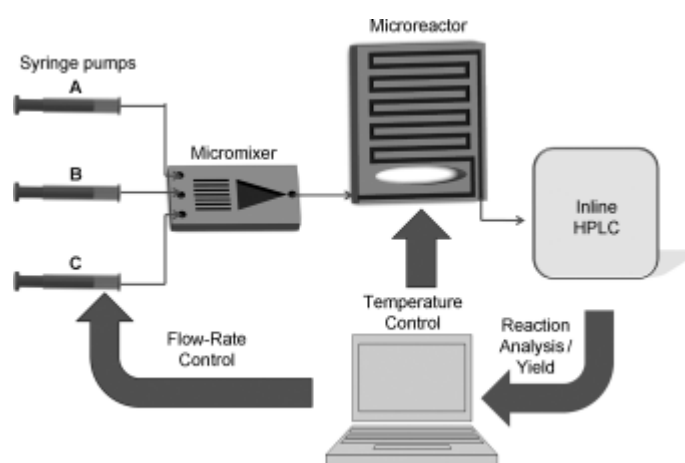

Figure 1.20: The first microreactor chip designed for online analysis⁶⁶

An example that includes online analysis and also a self-optimisation technique was reported by Jensen *et al.* for a Heck reaction (Scheme 1.18).⁷⁰ The microreactor system (Figure 1.21) comprises of three reagent syringes connected to a micromixer, once the reaction is complete, the solution was diluted with acetonitrile and analysis by HPLC was carried out. This information was then sent to a computer with a Nelder-Mead search algorithm. The system was allowed to vary both the ratio of the alkene to aryl chloride and also residence times for the reaction. The system was able to optimise the reaction conditions giving a residence time of 6 minutes with 5 equivalents of alkene to give a maximum yield of 80% (2 hour reaction gave 26.9g of product, estimated to be 114 kg per year) after 19 automated experiments.^{61,66}



Scheme 1.18: A Heck reaction in flow

Figure 1.21: Computer controlled optimisation for Heck reactions⁶⁶

One of the most interesting developments in microreactor technology is remote controlled synthesis being monitored by digital cameras. In a review by Ley *et al.*⁷¹ reactions being monitored by digital cameras can not only make changes to reaction conditions, but can now send images to the chemist's mobile phone to allow them to remotely control the reaction.

An example from Ley *et al.*⁸⁰ is interesting not only because it is a microreactor system for synthesis, but it has an online liquid-liquid extraction system integrated and controlled by a camera. Liquid-liquid extraction is an important practice for synthetic chemists. To demonstrate their system, the authors used hydrazine formation or alkene epoxidations with excess reagents being extracted into the aqueous layer during separations. The organic layer containing the pure organic product requires no further workup other than removal of the solvent, and the products were obtained in high purities and yields. For the separation to work

continuously with no human control, a computer programme was written to control a digital camera which monitored the solvent interface in the separation column to keep it constant by remotely controlling the flow rates of the reagent streams.

The same group then furthered this method to include a triple extraction method for the production of valuable chiral hydroxyacids from the diazotisation of amino acids for the first time in flow.⁸¹ Figure 1.22 shows the complete reaction setup for online liquid-liquid extractions developed by the group.

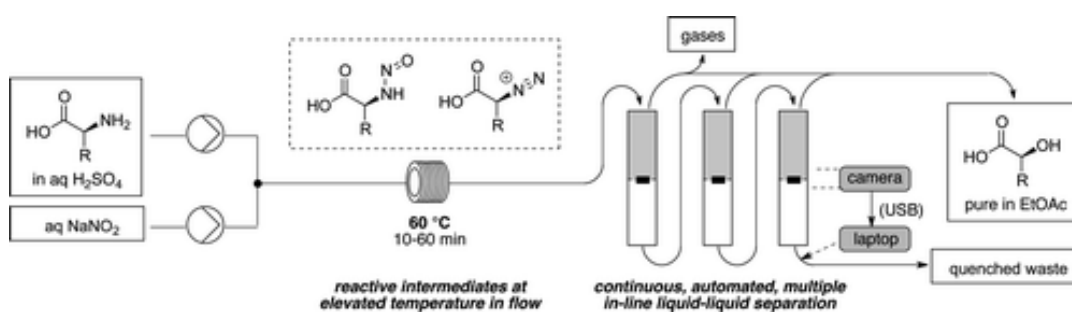

Figure 1.22: Schematic representation of an online triple liquid-liquid extraction⁸¹

2.4.7 Scaling up reactions

The ease of scaling up microflow syntheses is a very appealing factor, especially for industrial processes. This is because once the reaction in question has been optimised, no further reactions need to be carried out for large scale production. Two methods are available for microreactor scale up, either the reagent reservoirs are increased in volume and the reaction run for greater lengths of time, or many reactors can be set up in parallel.

One example to illustrate this is a procedure by Polomski *et al.*⁶¹ for a Claisen rearrangement-cyclisation (Scheme 1.19). The rearrangement is key step in the preparation of a drug candidate, and a significant temperature increase was observed when carried out in a batch reaction (180 – 445 °C). The flow reaction was carried out in a stainless steel tubing and was heated to 220 °C. The residence time of the reaction was investigated but the reaction product was observed in > 96% conversion at all residence times investigated. Once scaled up, the product was achieved with a yield 91% and a total throughput of 7 kg h⁻¹. Also the purity of the product was

improved to > 96% when 40 g batches were run, this purity in flow was reproducible and three more 40 g runs gave identical purities.^{61,63}

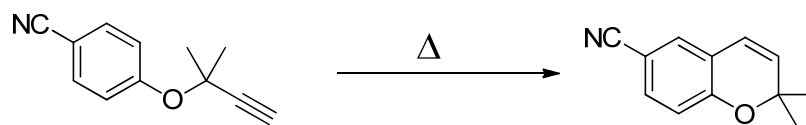

Scheme 1.19: A Claisen rearrangement-cyclisation as a key step in a drug synthesis

2.5 Pumping techniques

Control of fluid pumping in microreactors can be divided into two techniques, hydrodynamic pumping (pressure driven flow) or electrokinetic flow. The first is the more popular technique used, this is because flow is obtained by the use of syringe pumps to apply pressure to the system forcing the solution through the channels, other pumps available include HPLC pumps. Hydrodynamic pumping has the advantage over electrokinetic flow because it can be used for any solvent and any microreactor device. It does however have a disadvantage due to the flow profile created when the solution moves through the channels. The flow profile has a parabolic shape, as it enters the channel the flow profile is flat across it, however as the solution progresses through the channel the parabolic shape is created by the solution in the centre of the channel moving faster than that in contact with the channel walls (Figure 1.23 a).⁵²

Electrokinetic flow is created by applying a potential difference between the channel inlet and the channel outlet with electrodes placed in the solution reservoirs. There are two factors responsible for this type of pumping technique, the first is the movement of ions in solution to move towards the oppositely charged electrode. The second factor, electroosmotic flow is created due to the electrical double layer that forms on channel walls with charged surfaces (Figure 23b). If, for example, the channels are constructed of glass or silica, the channels possess a negatively charged surface due to the partial ionisation of hydroxyl groups on the surface. The benefit of this technique is the flow profile, it is almost flat across the channel, however the technique is only possible when polar solvents such as water or methanol are used, it also requires a more difficult system setup when compared to a syringe pumping method.⁵²

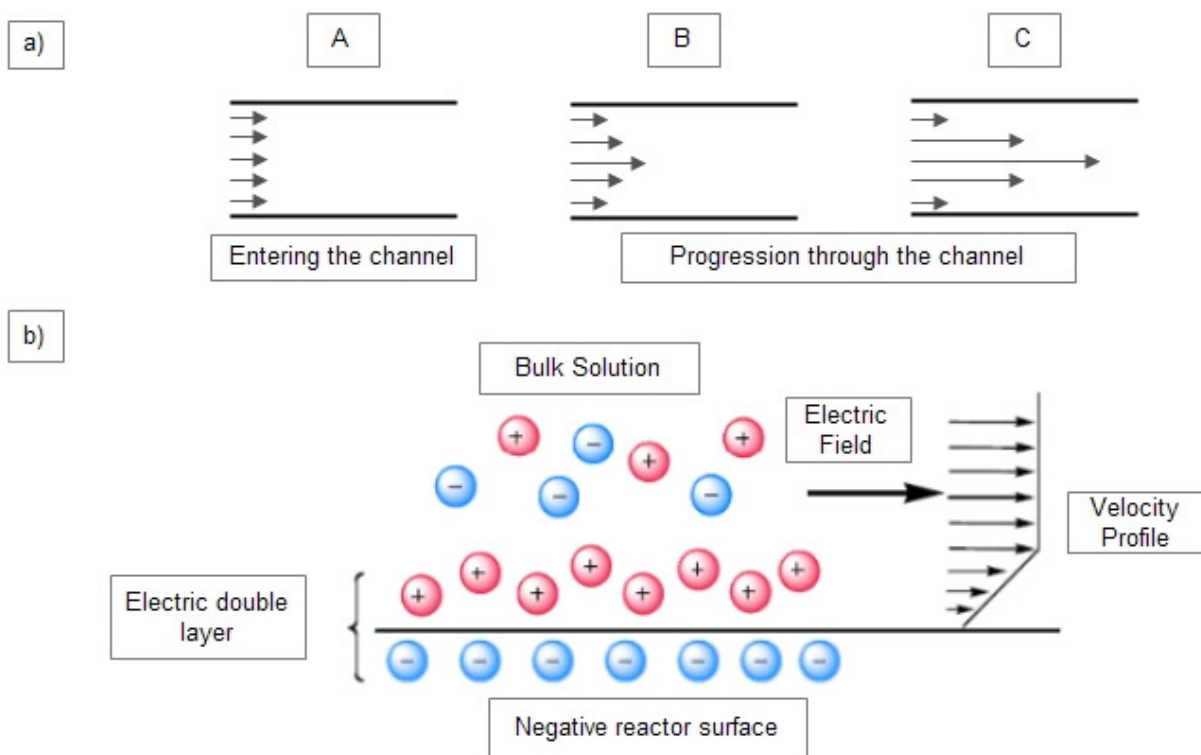

Figure 1.23: Flow profiles through microchannels by a) hydrodynamic, b) electrokinetic pumping techniques

2.6 Interfacial reactions

The interface between two liquids is able to facilitate the reaction between two reagents dispersed in immiscible phases. Yang *et al.*⁵⁸ have devised a method in flow for creating a spherical liquid-liquid interface by dispersing one liquid into the other forming droplets. A phase transfer catalyst is needed to catalyse the reaction between the organic and aqueous phase and assembles at the solution interface (depicted with an orange line) with the polar functional group in the aqueous phase and the alkane tail in the organic phase (Figure 1.24 left). This method clearly shows an advantage compared to a batch flask for increasing the surface-to-volume ratio dramatically, with every dispersed droplet essentially being analogous to that of a conventional flask reaction, simultaneously increasing the rate of mass transfer. The reaction studied by the authors was the nucleophilic reaction between benzyl bromide in the organic phase, and phenoxide formed by the addition of phenol to aqueous sodium hydroxide, using tetrabutylammonium bromide to act as both a phase transfer catalyst and a surfactant. The results clearly show an advantage for the flow system, in batch the reaction time was three hours, compared to a one minute residence time

for the flow system with conversions of 96 and 95%. The rate of flow was also investigated (Figure 1.24 right) a) represents the droplet formation with a residence time of 2.3 minutes, as the residence time was decreased, the droplets become more dispersed, increasing the surface-to-volume ratio and increasing the conversion from 71% to 95%

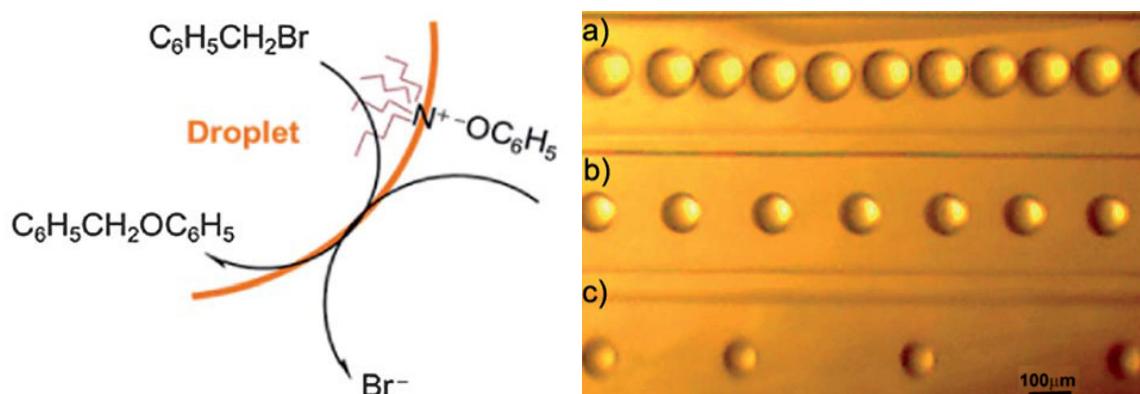

Figure 1.24: A diagram showing a) The liquid-liquid interface between two immiscible liquids and b) An optical micrograph of dispersed droplets with decreasing flow rates.

3. Electrochemical Microreactors

Electrochemistry and microreactor technology can of course be combined and create microreactors capable of electroorganic synthesis, however the amount literature surrounding the subject is small, and there are very few reviews available detailing benefits of electrochemical microreactors, fabrication methods and synthesis combined. This section is presented in the style of a review concentrating on organic syntheses that have been carried out in electrochemical microreactors, but is by no means comprehensive.

3.1 Advantages of electrochemical microreactors

As previously mentioned in section one of this general introduction, the disadvantages of conventional electrochemistry include factors such as a non-homogeneous electrical field in the reaction vessel causing “hot-spots”, and supporting electrolytes have to be added to the reaction solutions to improve current flow through the reaction vessel.

Microreactors for electrosynthesis have been designed and are able to overcome these limitations of conventional electrochemistry. Firstly because the reaction solution flows through the device between the electrodes the presence of “hot spots” during the reaction are eliminated making the reaction more reliable. Good heat and mass transfer properties of microreactors also attribute to this and Figure 1.25 compares these effects with a conventional batch reactions.⁸²

The high surface-volume ratio of the electrode area to the reaction solution and the close proximity of the electrodes also allow for more efficient reactions. Not only does the close proximity of the electrodes negate the presence of a large current gradient as present in a batch reactor (Figure 1.25), but it also allows for a unique aspect of microreactors for electroorganic synthesis. This is the ability to conduct electrochemistry without the use of supporting electrolytes because the two diffusion layers of the electrodes (Section 1.5) are able to overlap. The ions generated at the electrode surfaces are able to diffuse through the solution and carry the electrical charge and complete the electrical circuit.^{13,83}

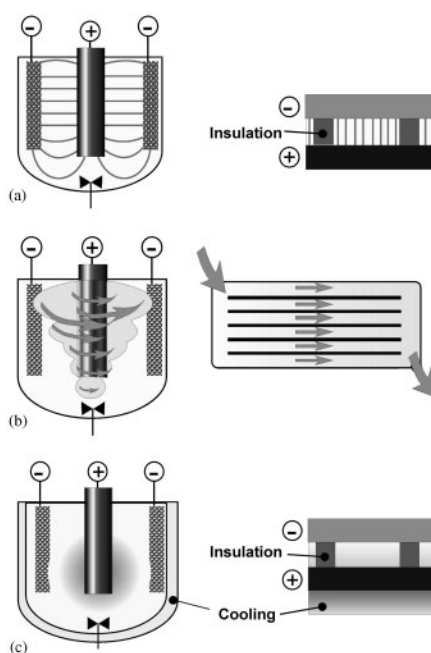

Figure 1.25: Batch/flow comparison. a) Current distribution, b) Mass transfer and c) Heat transfer

3.2 Designs of electrochemical microreactors

There are primarily three types of microreactor electrodes that have been designed and used for preparative electrochemical synthesis and only these will be discussed along with syntheses that have been carried out in them.

It is important to mention that other electrochemical devices have been designed and developed for electrochemical sensing and this topic has been reviewed by Stradiotto *et al.*⁸⁴

3.2.1 Plate to plate electrodes

The first and the simplest method of microreactor fabrication is the use of plate to plate electrode geometries (Figure 1.26).⁸⁵ One of the first reported syntheses in a reactor of this type was reported by Löwe and Ehrfeld for the methoxylation of 4-methoxytoluene.^{86,87} This was however, in the presence of KF as a supporting electrolyte. They were able to significantly reduce the amount of supporting electrolyte needed than when carried out in a flask. This synthesis will be looked at in section 3.2.2 when divided microreactor cells are discussed for this synthesis reported by Yoshida *et al.*⁸⁸

One of the first unsupported electrosyntheses in a reactor of this design was reported by Marken *et al.*⁸⁹ for the two electron/two proton reduction of **13** dissolved in ethanol (Scheme 1.20). Comparison with and without supporting electrolyte showed that higher yields were obtained without supporting electrolyte in their plate to plate reactor constructed of metal films (1 cm x 5 cm) glued onto a glass slides and separated by adhesive tape to create a central reaction channel and then it was sealed.⁸⁹



Figure 1.26: Schematic representation of a plate to plate electrochemical microreactor

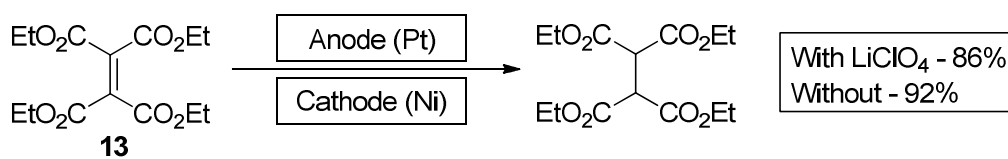

Scheme 1.20: The two electron/two proton reduction of **13**

Atobe *et al.*⁸⁵ used a similar setup for the anodic methoxylation of furan **14** (Scheme 1.21). They compared different electrode configurations to maximise the yield for the reaction, and achieved their best result when a glassy carbon anode was paired with a platinum cathode. Optimisation of the reaction conditions led to an almost quantitative conversion of **14** with a current density of 3 mA cm^{-2} and a range of flow rates between $0.01\text{-}0.1 \text{ mL min}^{-1}$. The cell was simply constructed with plate electrodes ($3 \text{ cm} \times 3 \text{ cm}$) separated by an adhesive tape ($80 \mu\text{m}$ thick) to create a centre channel with an area of $1 \times 3 \text{ cm}^2$, sandwiched together and sealed with an epoxy resin. The workup after the reaction is a one-step procedure, the solvent has to be removed to give a pure product.

Haswell *et al.*⁹⁰ report the self-supported coupling of activated olefins with benzyl bromide **15** in DMF. Their microreactor consisted of two platinum electrodes with a working area of 45 mm^2 . The authors investigated inter-electrode distances of $160 \mu\text{m}$ and $320 \mu\text{m}$ as well as the effects of flow rates and current density. They achieved better results when the electrodes were closer, allowing a lower voltage. All three factors had effects on conversion, yields and unwanted side products. Yields of up to 99% were achieved with different substituted benzyl bromides and activated olefins (Scheme 1.22).

A second report by this group and using the same substrates and reaction conditions as previously reported investigates the scaling up of the synthesis.⁹¹ This was achieved by using two different microreactor electrode setups, by increasing the number of electrodes and by increasing the number of channels per electrode (Figure 1.27). Four configurations were tested, 1 electrode/2 channels, 2 electrodes/ 2 channels, 4 electrodes/4 channels and 1 electrode/4 channels. With the exception of

the latter, all configurations using **15** as a substrate gave 97/98% (determined by GC) in each of the parallel reactors.

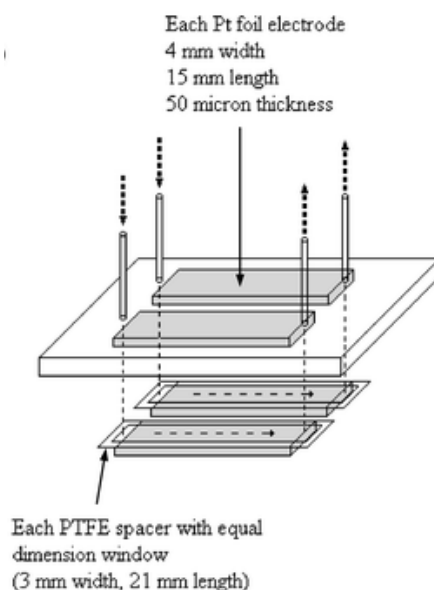
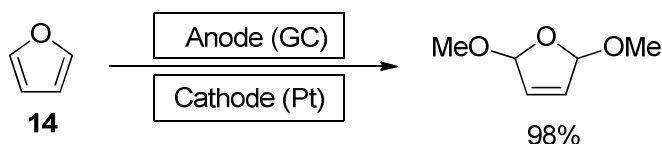
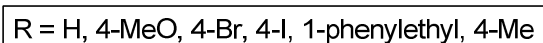
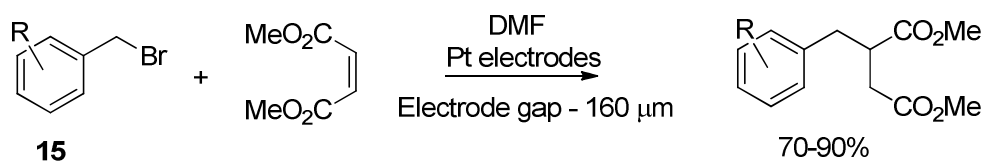

Figure 1.27: A schematic representation of a 2 electrode/2 channel parallel microreactor set up⁹¹



Scheme 1.21: The anodic methoxylation of furan



Scheme 1.22: The cathodic coupling of activated alkenes with **15**

Another report from the same group and using the same single cell microreactor with platinum electrodes shows the ability to synthesise pharmaceutically important intermediates in flow.⁹² Namely, the synthesis of phenyl-2-propanone **16** from **15** and its derivatives (Scheme 1.23). Using an inter-electrode gap of 160 μm , as previously reported to give better yields than a larger distance, a residence time of 43

seconds and a current of 1.1 mA, to achieve a conversion of 90% with an isolated yield of **16** 81% (determined offline by GCMS).

One last report received in the same period from this group describing the cathodic coupling of 4-nitrobenzylbromide **17**.⁹³ The authors investigate the same parameters as previously, *i.e.* flow rate, current density and inter-electrode distance. In this case however, it is the larger electrode distance that generates the highest yields. This is explained due to the closer electrode distance allowing the anode to cause some interference in the reaction and leading to a larger amount of the monomeric side product. The best results of 92% conversion with a 91:9 ratio of dimeric product to monomeric side product was with a 320 μm electrode distance, 2.5 mA and a residence time of 40 seconds (scheme 1.24).

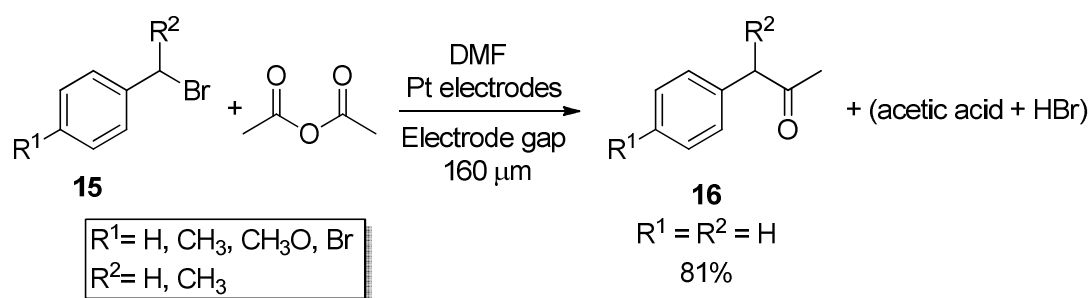

Scheme 1.23: Unsupported electrosynthesis of phenyl-2-propanone **16**

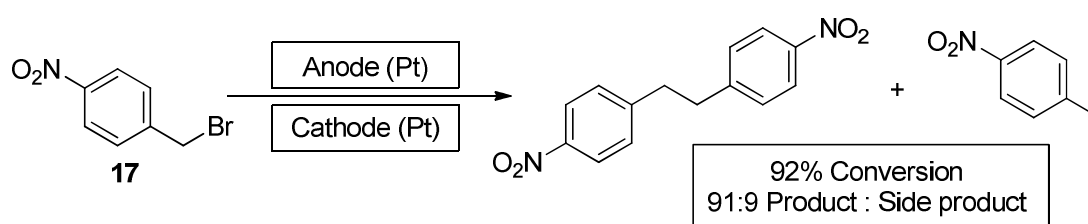

Scheme 1.24: Cathodic dimerisation of 4-nitrobenzylbromide **17**

More recently, Birkin *et al.*⁹⁴ reported the fabrication of a simple and inexpensive microreactor developed for the methoxylation of *N*-formylpyrrolidine **18** and 4-*t*-butyl toluene **19** (Scheme 1.25). The reactor is constructed in a circular design (100 mm diameter) with a graphite plate anode and a stainless steel cathode. The spacer forming the reaction channel was laser cut in a star shape out of Viton (a fluoropolymer elastomer), giving a total channel length of 600 mm (Figure 1.28). The methoxylation of **18** was optimised to give conversions of up to 96% with an isolated yield of 87%. The second reaction was less successful in terms of yields and

conversions with a 64% conversion leading to product yields of 39% and 25% of the aldehyde and acetal respectively with a cell current of 50 mA. The lower yield was explained to be due to the cell current being below that needed for full mass transport control, which is also the reason for the high yield of the aldehyde side product.

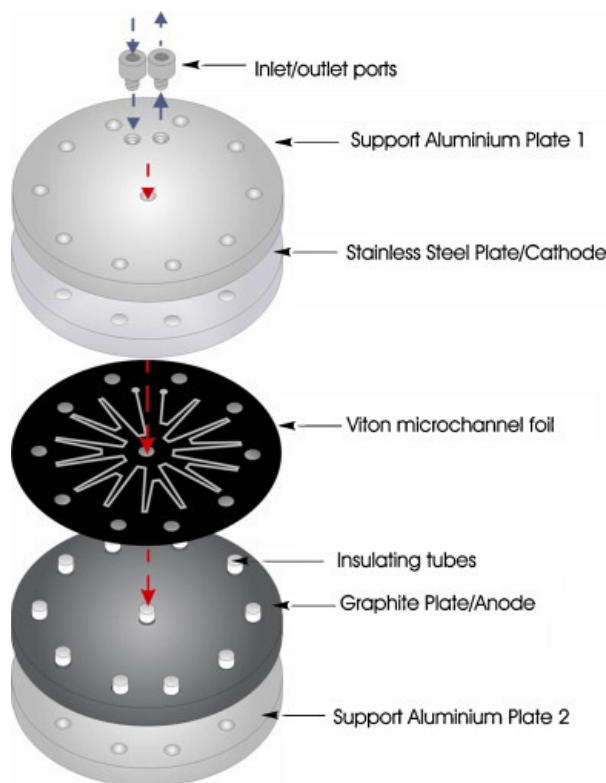
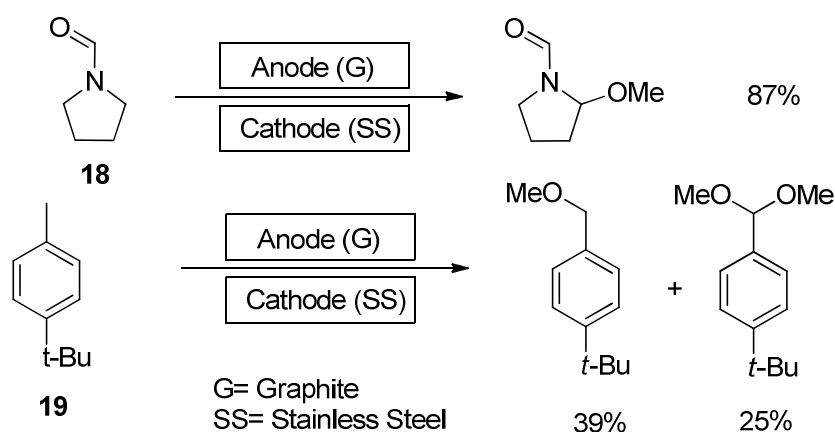

Figure 1.28: An electrochemical microreactor with an elongated channel.⁹⁴



Scheme 1.25: Anodic methoxylations

The same group then investigated anodic methoxylation of **18** to design and fabricate a microreactor which is more suitable for a saleable commercial flow package that would appeal to the non-electrochemist.⁹⁵ The aim was to create a device further miniaturised than the previous (Figure 1.28), easier and more convenient to use so as to be more accepted by traditional organic chemists. They also wanted a high single pass conversion of the substrate, to achieve this they changed their circular design to a rectangular shape and incorporated a “snaking” channel design into the spacer, creating a channel length of 700 mm (Figure 1.29) and a working electrode area of 1050 cm². With this new design, they were able to increase the previous conversion to > 90% in most cases, and with a high purity of product without any organic side products.

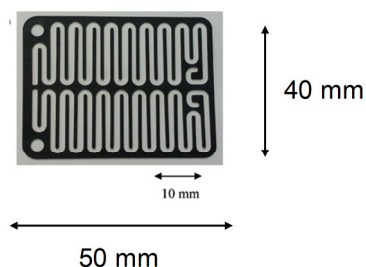
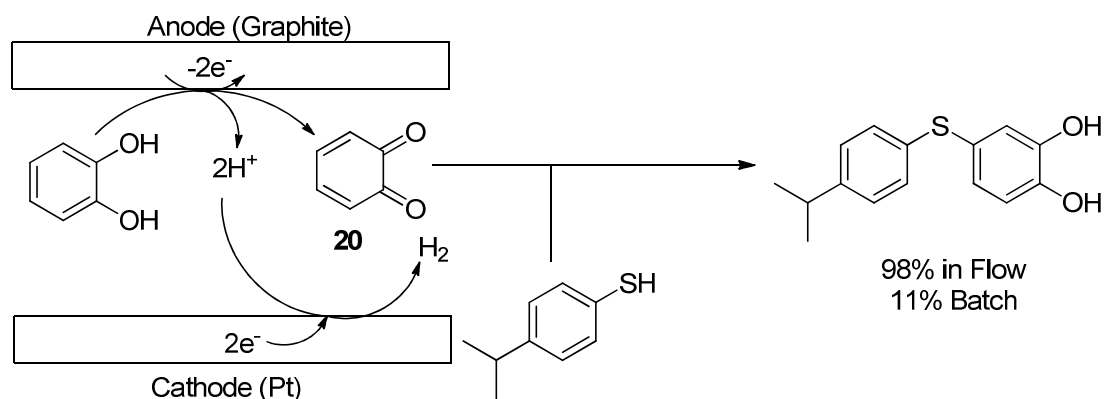

Figure 1.29: A snaking channel design

An example of electrosynthesis to highlight another advantage of microreactor synthesis, the ability to generate and use subsequently unstable intermediates is reported by Atobe *et al.*⁹⁶ They report the synthesis of diphenylsulfide derivatives from the generation of the unstable *o*-benzoquinone intermediate **20** (Scheme 1.26). Compound **20** is generated by the electrochemical oxidation of catechol in the microreactor at a graphite anode with hydrogen being formed at the cathode. Once the reaction solution leaves the microreactor, it joins a stream of a benzenethiol derivative and undergoes a rapid Michael addition giving the product. The best results obtained were with an isopropyl substituted benzenethiol and the electrogenerated intermediate **20** giving a total isolated yield of 88%, in comparison to a batch type reaction yielding 13%. The inter-electrode distance was 80 μm with a current density of 1.5 mA cm⁻². This, however, is not an unsupported synthesis, the authors report the use of sodium perchlorate as a supporting electrolyte.



Scheme 1.26: The use of unstable electrogenerated intermediates and subsequent chemical reactions

A microreactor designed and fabricated by Roth *et al.*⁹⁷ has been used to investigate four- and six-electron benzylic oxidations. The reactor electrodes used vary from carbon fluoropolymer (PVDF) hybrids, to stainless steel and platinum separated by a gasket similar to that in Figure 1.29. The device is capable of operating with pressures up to 6.5 bar and temperatures ranging from 0 to 65 °C. The authors carry out experiments on toluene derivatives and vary flow rates, electrode materials and the number of electrons ($F \text{ mol}^{-1}$) transferred to the substrate, they do use a supporting electrolyte for many of the syntheses but they do investigate the oxidation of *p*-methoxy toluene in the absence of supporting electrolyte. The selectivities and yields of the reactions are poor to reasonable in most cases, with the highest yield of *p*-methoxy dimethylacetal 64% achieved in the electrolyte free synthesis, with 33% and 3% respectively of the corresponding aldehyde and ester. They conclude that not one general protocol can be effective for a variety of electron rich and deficient aromatics and each substrate requires individual optimisation to achieve the highest yields.

Carbon-carbon cross coupling reactions have recently been achieved in an electrochemical microreactor consisting of boron-doped diamond (BDD) anode and a nickel cathode reported by Waldvogel *et al.*⁹⁸ The electrodes were separated by both side adhesive tape, as previously described by a number of authors, to leave a reactor channel (1 x 3.5 cm²). The reaction involving **21** and **22** (Scheme 1.27), in the best case gave a total yield of the two coupling products of 90% at 2.8 mA cm⁻²

when acetic acid was used as the solvent. This was said to be due to the acetic acid stabilising the cation radicals and not acting as a nucleophile, extending the lifetime of the radical. Whereas methanol gave a much lower yield, 5%, the selectivity of the cross coupling product was > 99:1, in contrast to a 2:1 ratio in acetic acid.

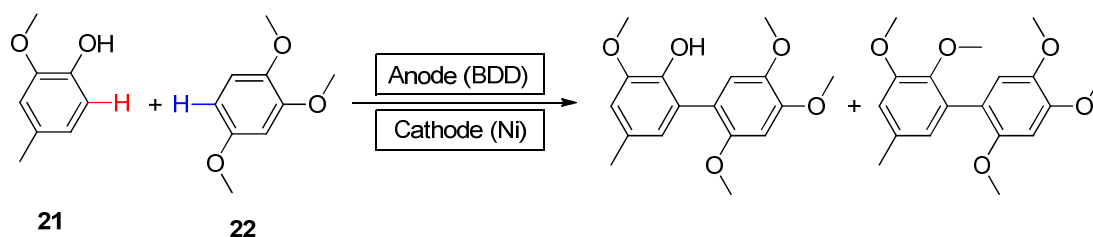

Scheme 1.27: A carbon-carbon cross coupling reaction in flow

There are also many other reactions involving paired and coupled electrode processes like that shown in (Scheme 1.4) the BASF paired synthesis of phthalide **3** and *t*-butylbenzaldehyde dimethylacetal **4** but there is a comprehensive review detailing these reactions by Marken *et al.*¹³

3.2.2 Divided cell microreactor synthesis

Yoshida *et al.*⁸⁸ developed an electrochemical microreactor for divided cell electrolysis. Their device was constructed from two carbon fibre electrodes separated by a porous membrane (Scheme 1.28). An advantage of their electrode construction is the fact that the electrodes are porous, this inherently increases the surface area of the electrodes greatly. They chose to study the methoxylation of *p*-methoxytoluene as a test reaction because it is a well-known process and industrially important. The process is essentially the same as in a batch divided cell, the substrate enters the anodic chamber of the device and is oxidised, the acetal formed along with the generated protons move through the porous membrane into the cathodic chamber where the product leaves the device. They were able to achieve yields of more than 90% with a current of 11 mA.

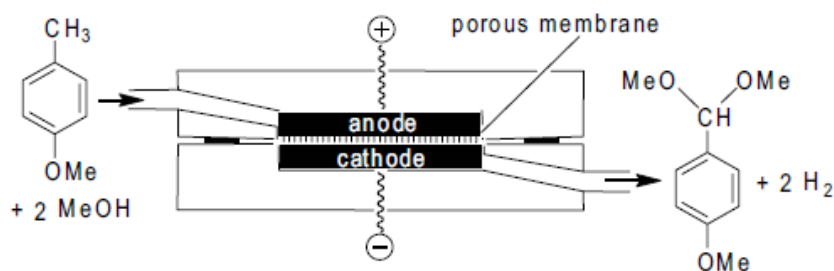

Scheme 1.28: A schematic diagram for the anodic methoxylation of *p*-methoxytoluene in a divided microcell

Yoshida *et al.*⁹⁹ also developed an interesting procedure based on the “cation pool” method that they had previously developed in batch chemistry, the electrochemical formation of highly reactive carbocations and subsequent nucleophilic reactions. The “cation flow” method has been developed to use the same principles.¹⁰⁰ They chose to use carbamates as their substrates because they had developed the “cation pool” method using these substrates. The substrate with a supporting electrolyte was fed into the anodic chamber of the device and trifluoromethanesulfonic acid was fed into the cathodic chamber as a source of protons. The *N*-acyliminium cation **22** then exits the device and is analysed online using infrared spectroscopy to monitor the formation of **22**, a subsequent combination with a nucleophile gives the desired product (Scheme 1.29).¹⁰

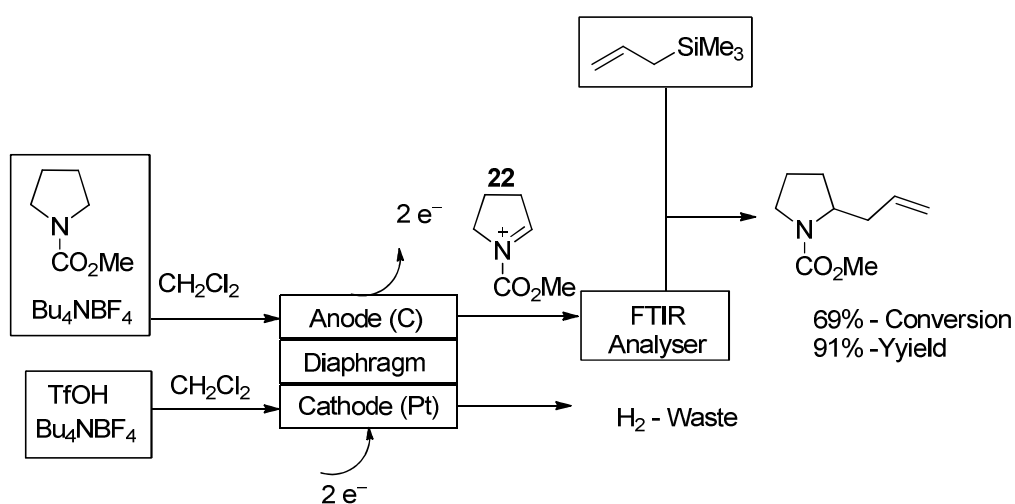

Scheme 1.29: Schematic representation of the “cation flow” method¹⁰¹

This principle was then taken further, not only using different cation sources and nucleophiles, but to achieve continuous sequential combinatorial chemistry.⁹⁹ This is

achieved by a simple switching of the flow of **22** into separate streams of nucleophiles, leading to three different products formed in parallel (Scheme 1.30).¹⁰

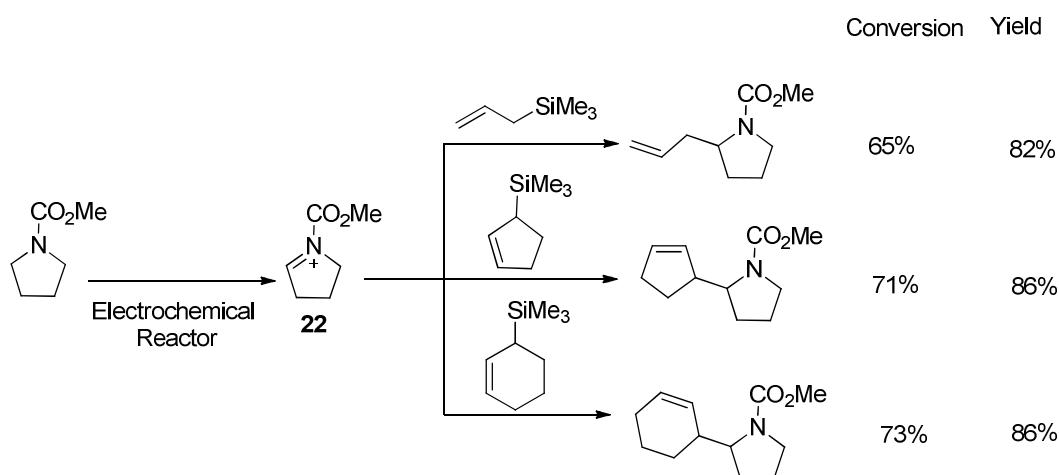

Scheme 1.30: Combinatorial chemistry with the “cation flow” method¹⁰¹

The group was then able to take the “cation flow and cation pool” methodologies and apply it to complete a variety of different reactions and not just a variety of substrates and nucleophiles. A selective Friedel-Crafts monoalkylation (Scheme 1.31 a), when carried out using a micromixer instead of a batch reactor, the yield of monoalkylated product was up to 92% with 4% of dialkylated product, when compared to a flask reaction the yields were 37% and 32% respectively.¹⁰² [4+2] cycloaddition reactions (Scheme 1.31 b),¹⁰³ as well as controlled/living cationic polymerisation reactions (Scheme 1.31 c) were also successfully undertaken.^{10,104}

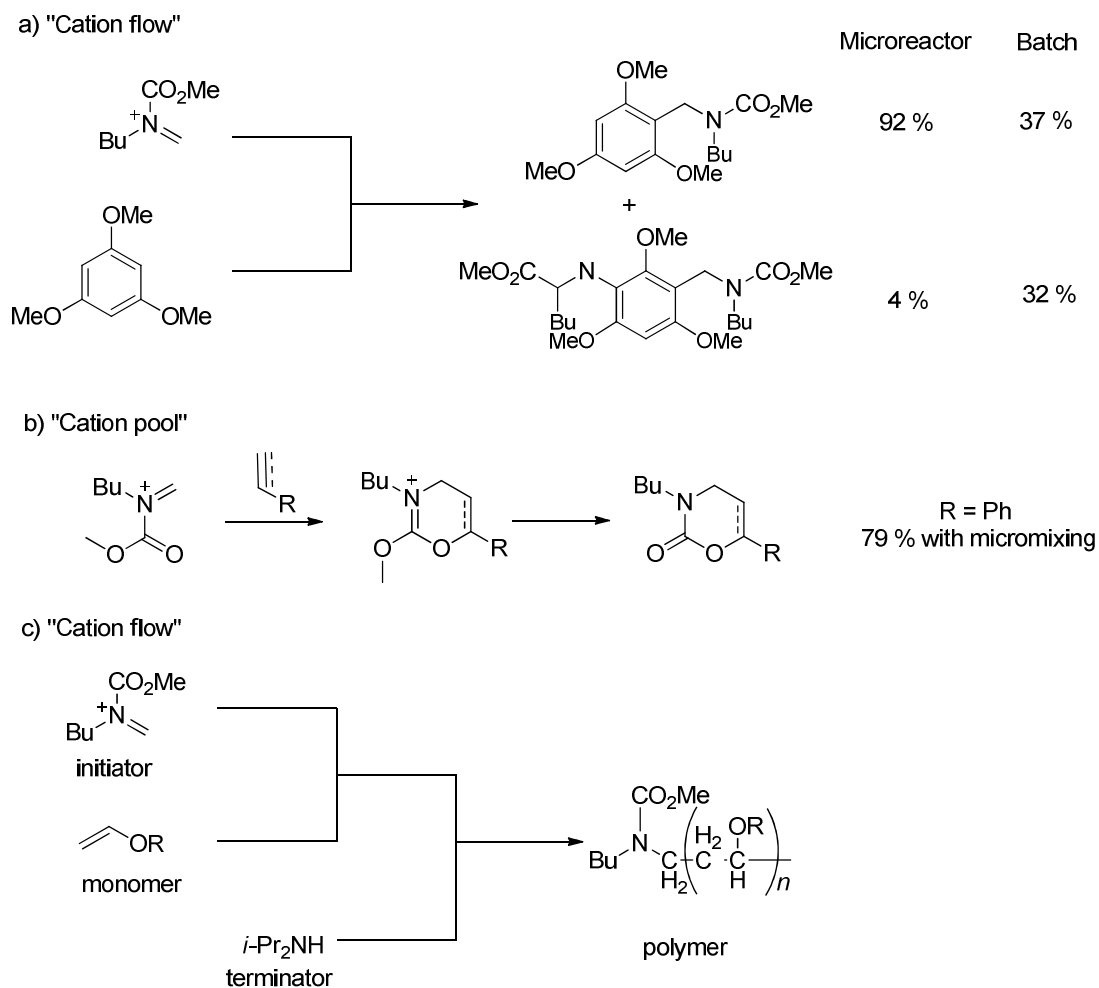

Scheme 1.31: Examples of synthesis using "cation flow" and "cation pool" methods, a) Friedel–Crafts monoalkylation, b) [4+2] cycloaddition, c) cationic polymerisation

One final example from Yoshida *et al.*¹⁰¹ involves paired electrosynthesis in a divided cell. It is an interesting example because the *N*-acyliminium ion **22** generated by anodic oxidation in the anodic compartment was directly reacted with a substrate that has been cathodically reduced in the cathodic chamber. Once leaving the device and combined they were able to achieve good yields and conversions (Scheme 1.32).

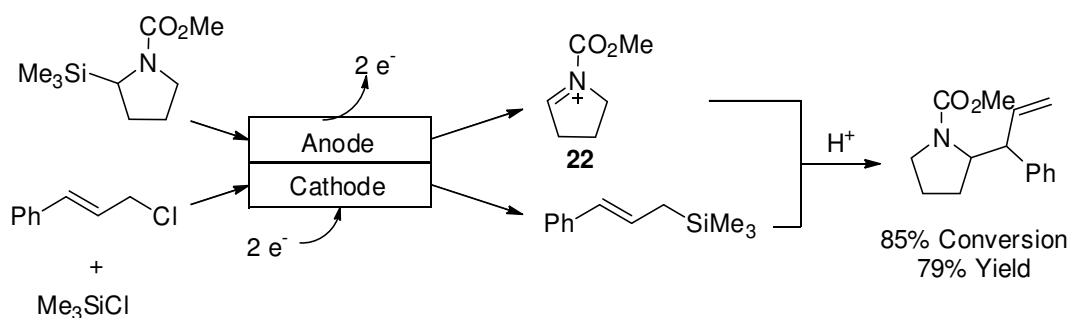

Scheme 1.32: Paired electrosynthesis using a divided microcell and the “cation flow” method¹⁰¹

3.2.3 Interdigitated band electrodes

Interdigitated band electrodes are probably the least reported for organic syntheses, they are however quite popular for electrochemical sensing applications.¹⁰⁵ Complex electrode shapes can be developed via the process shown below (Figure 1.29) however methods such as screen printing using a metallic ink can be just as successful.

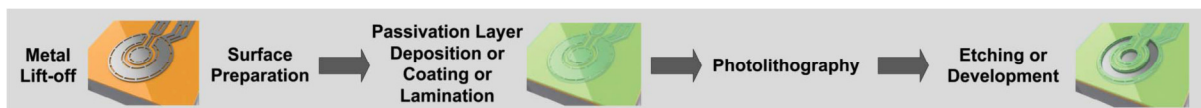

Figure 1.29: General procedure for constructing Interdigitated band electrodes.¹⁰⁵

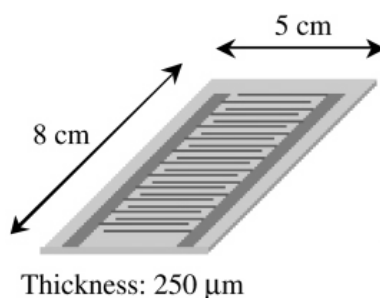
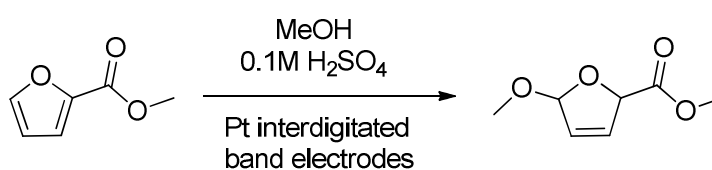

Figure 1.30: An example of an Interdigitated band electrode array.¹⁰⁶

Belmont *et al.*¹⁰⁷ describe the methoxylation of furan with their aim being to apply microelectrode technology for production of large scale electrodes with micrometer inter-electrode distances. They were able to do this at a low cost by screen printing the electrode designs using a platinum paste on alumina (Figure 1.30). When the

inter-electrode distance was reduced, the yield, current efficiency and overall energy consumption improved.

In another example reported by Girault *et al.*¹⁰⁶ a ceramic microreactor was used to investigate the methoxylation of methyl-2-furoate (Scheme 1.33). They also fabricated their band electrodes using a screen printing method (Figure 1.30). The reactor was sealed using a sintering technique at 850 °C and they utilised an online monitoring system by incorporating a mass spectrometer in the system connected directly to the outlet of the microreactor (Figure 1.31).



Scheme 1.33: The anodic methoxylation of 2-methylfuroate

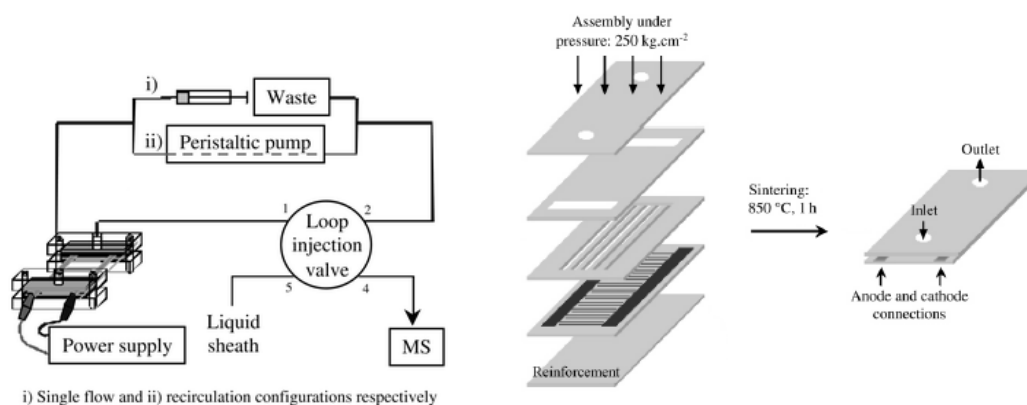

Figure 1.31: Left a schematic representation of the ceramic microreactor with online mass spectrometry, right assembly procedure.

As it can be seen from the above electrochemical syntheses, microreactors have been well established as a successful and useful alternative to batch reaction techniques in the world of electroorganic chemistry. It cannot be used in all cases but can give a useful alternative to conventional techniques when there are problems with the synthesis such as poor heat and mass transfer properties lowering yields and losing product selectivity. Making processes that can deliver high throughputs of valuable compounds to pharmacy and other industries is easily achievable once the initial process has been developed in a microflow cell, either by using more parallel

reactors or leaving the reaction to run continuously with no time-limit. The absence of supporting electrolytes in electrochemical reactors is a very interesting prospect because it simplifies the reaction work-up as no aqueous extraction is needed to and it keeps overall costs of syntheses lower. This proves that the technology, now no longer in its infancy can have a dramatic effect on conventional methods and play a part in what is now becoming a major goal in all areas of chemistry, the ability to make current methods “green” and better for the environment.

4. References

1. A. Volta, *Philos. Trans. R. Soc. London*, **1800**, 90, 403.
2. W. Nicholson, *J. Nat. Philos. Chem. Arts*, **1801**, 4, 179.
3. M. Faraday, *Philos. Trans. R. Soc. London*, **1834**, 124, 77.
4. M. J. Allen, *Platin. Met. Rev.*, **1959**, 3, 131.
5. H. Kolbe, *Liebigs Ann. der Chemie*, **1848**, 69, 257.
6. B. Speiser, *Encyclopedia of Electrochemistry Volume 8*, Wiley-VCH, 2004.
7. A. J. Fry, *Electrochem. Soc. Interface*, **2009**, 28.
8. D. M. F. Santos and C. A. C. Sequeira, *J. Braz. Chem. Soc.*, **2009**, 20, 387.
9. J. Utley, *Chem. Soc. Rev.*, **1997**, 26, 157.
10. J.-I. Yoshida, *Electrochem. Soc. Interface*, **2009**, Summer, 40.
11. M. M. Baizer, *Naturwissenschaften*, **1969**, 56, 405.
12. H. Lund and O. Hammerich, *Organic Electrochemistry*, CRC Press, 4th edn., 2001.
13. F. Marken, C. Paddon, M. Atobe, T. Fuchigami, P. He, P. Watts, S. J. Haswell, G. J. Pritchard, and S. D. Bull, *J. Appl. Electrochem.*, **2006**, 36, 617.
14. A. J. Fry and Y. Matsumura, *New Directions in Organic Electrochemistry*, The Electrochemical Society, Inc., 2000.
15. K. D. Moeller, *Tetrahedron*, **2000**, 56, 9527.
16. A. Hamnett and P. A. Christensen, *Techniques and Mechanisms in Electrochemistry*, Blackie Academic & Professional, 1st edn., 1994.

17. D. Evans, *Chem. Rev.*, **1990**, *90*, 739.
18. D. Pletcher and M. Fleischmann, *R. Inst. Chem. Rev.*, **1969**, *2*, 87.
19. D. C. Grahame, *Chem. Rev.*, **1947**, *41*, 441.
20. C. M. A. Brett and A. Brett, *Electrochemistry- Principles , Methods , and Applications*, Oxford University Press, 1993.
21. S. Srinivasan, *Fuel cells, from fundamentals to applications*, Springer, 2006.
22. C. Zoski, *Handbook of Electrochemistry*, Elsevier, 1st edn., 2007.
23. K. B. Oldham, *J. Electroanal. Chem.*, **2008**, *613*, 131.
24. L. R. Faulkner, *J. Chem. Educ.*, **1983**, *60*, 262.
25. R. Parsons, *Chem. Rev.*, **1990**, *90*, 813.
26. A. J. Bard and L. R. Faulkner, *Fundamentals and Applications*, John Wiley & sons, 2nd edn., 2001.
27. J. Bockris and A. Reddy, *Modern Electrochemistry 1*, Kluwer Academic Publishers, 2nd edn., 2002.
28. F. D. Popp and H. P. Schultz, *Chem. Rev.*, **1962**, *62*, 19.
29. T. Shono, *Electroorganic Synthesis*, Academic Press Limited, 1991.
30. L. Ebersson, B. Helgee, K. Nyberg, R. Servin, and H. Sternup, *Acta Chem. Scand.*, **1975**, *29*, 617.
31. D. Pletcher, F. C. Walsh, and A. Couper, *Chem. Rev.*, **1990**, *90*, 837.
32. J. Wang, *Analytical Electrochemistry*, Wiley-VCH, 2nd edn., 2001.
33. A. J. Bard, *Pure Appl. Chem.*, **1971**, *25*, 379.
34. I. M. Kolthoff, *Pure Appl. Chem.*, **1971**, *25*, 305.
35. H. House, E. Feng, and N. Peet, *J. Org. Chem.*, **1970**, *36*, 2371.
36. K. D. Moeller and R. D. Little, *Electrochem. Soc. Interface*, **2002**, *11*, 36.
37. T. Shono, N. Kise, T. Suzumoto, and T. Morimoto, *J. Org. Chem.*, **1986**, *108*, 4676.
38. H. J. Schafer, *Angew. Chemie, Int. Ed. English*, **1981**, *20*, 911.

39. H. J. Schäfer, *Comptes Rendus Chim.*, **2011**, *14*, 745.
40. M. M. Baizer, *J. Electrochem. Soc.*, **1964**, *111*, 215.
41. H. J. Schäfer, M. Harenbrock, E. Klocke, M. Plate, and A. Weiper-Idelmann, *Pure Appl. Chem.*, **2007**, *79*, 2047.
42. K. N. Singh and A. K. Shukla, *J. Sci. Ind. Res.*, **1999**, *58*, 327.
43. E. Steckhan, *Angew. Chemie, Int. Ed. English*, **1986**, *25*, 683.
44. F. Geneste, C. Moinet, S. Ababou-girard, and F. Solal, *New J. Chem.*, **2005**, *29*, 1520.
45. A. M. Elizarov, R. M. Van Dam, Y. S. Shin, H. C. Kolb, C. Padgett, D. Stout, J. Shu, J. Huang, A. Daridon, and R. James, *J. Nucl. Med.*, **2010**, *51*, 282.
46. D. M. Roberge, L. Ducry, N. Bieler, P. Cretton, and B. Zimmermann, *Chem. Eng. Technol.*, **2005**, *28*, 318.
47. *The micromixer - "Comet X-01" (Techno Applications Co., Ltd., 34-16-204, Hon, Denenchofu, Oota, Tokyo 1450072, Japan), .*
48. L. Cronin, V. Dragone, V. Sans, M. H. Rosnes, and P. J. Kitson, *Beilstein J. Org. Chem.*, **2013**, *9*, 951.
49. T. Wirth, Ed., *Microreactors in Organic Synthesis and Catalysis*, Wiley-VCH, 2nd edn., 2013.
50. M. Brivio, W. Verboom, and D. N. Reinhoudt, *Lab Chip*, **2006**, *6*, 329.
51. P. Watts and C. Wiles, *Chem. Commun.*, **2007**, 443.
52. D. T. McQuade, B. P. Mason, K. E. Price, J. L. Steinbacher, and A. R. Bogdan, *Chem. Rev.*, **2007**, *107*, 2300.
53. L. Capretto, W. Cheng, M. Hill, and X. Zhang, *Top. Curr. Chem.*, **2011**, *304*, 27.
54. N.-T. Nguyen and Z. Wu, *J. Micromechanics Microengineering*, **2005**, *15*, R1.
55. F. E. Valera, M. Quaranta, A. Moran, J. Blacker, A. Armstrong, J. T. Cabral, and D. G. Blackmond, *Angew. Chemie, Int. Ed. English*, **2010**, *49*, 2.
56. T. Schwalbe, V. Autze, M. Hohmann, W. Stirner, C. P. Chemistry, and O. B. Street, *Org. Process Res. Dev.*, **2004**, *8*, 440.
57. R. Halder, A. Lawal, and R. Damavarapu, *Catal. Today*, **2007**, *125*, 74.

58. P. Yang, J. Ji, Y. Zhao, L. Guo, B. Liu, and C. Ji, *Lab Chip*, **2012**, *12*, 1373.
59. T. Wirth, D. A. Barrow, and B. Ahmed-omer, *Arkivoc*, **2011**, 26.
60. H.-R. Tseng, W.-Y. Lin, Y. Wang, and S. Wang, *Nano Today*, **2009**, *4*, 470.
61. N. Polomski, Robert ESoundararajan, R. J. Bogaert-alvarez, P. Demena, G. Kodersha, and S. S. Y. Wang, *Chem. Process Res. Dev.*, **2001**, *5*, 2759.
62. D. Kirschneck and G. Tekautz, *Chem. Eng. Technol.*, **2007**, *30*, 305.
63. C. Wiles and P. Watts, *Green Chem.*, **2012**, *14*, 38.
64. J. Yoshida, *Chem. Rec.*, **2010**, *10*, 332.
65. T. Wirth and M. Rasheed, *Angew. Chemie, Int. Ed. English*, **2011**, *50*, 357.
66. D. Belder, M. Ludwig, L.-W. Wang, and M. T. Reetz, *Angew. Chemie, Int. Ed. English*, **2006**, *45*, 2463.
67. T. Wirth and J. C. Brandt, *Beilstein J. Org. Chem.*, **2009**, *5*.
68. X. Zhang, S. Stefanick, and F. J. Villani, *Org. Process Res. Dev.*, **2004**, *8*, 455.
69. T. Wirth, J. Brant, S. Elmore, and R. Robinson, *Synlett*, **2010**, 3099.
70. K. F. Jensen, S. L. Buchwald, J. P. McMullen, and M. T. Stone, *Angew. Chemie, Int. Ed. English*, **2010**, *49*, 7076.
71. S. V Ley, R. J. Ingham, M. O'Brien, and D. L. Browne, *Beilstein J. Org. Chem.*, **2013**, *9*, 1051.
72. J. Sedelmeir, L. Ley, M. Baumann, and I. Baxendale, *Org. Lett.*, **2010**, *12*, 3618.
73. J. Yoshida, A. Nagaki, T. Iwasaki, and S. Suga, *Chem. Eng. Technol.*, **2005**, *28*, 259.
74. V. Hessel, W. Ehrfeld, K. Golbig, H. Lo, and T. Richter, *Ind. Eng. Chem. Res.*, **1999**, *38*, 1075.
75. S. Taghavi-moghadam, A. Kleemann, and K. G. Golbig, *Org. Process Res. Dev.*, **2001**, *5*, 652.
76. K. F. Jensen, R. L. Hartman, and J. P. McMullen, *Angew. Chemie, Int. Ed. English*, **2011**, *50*, 7502.

77. J. R. Bloomquist, Y. Jiang, D. Swale, P. R. Carlier, J. a. Hartsel, M. Ma, and F. Ekström, *Pestic. Biochem. Physiol.*, **2013**, *106*, 156.
78. A. R. Bogdan, S. L. Poe, D. C. Kubis, S. J. Broadwater, and D. T. McQuade, *Angew. Chemie, Int. Ed. English*, **2009**, *48*, 8547.
79. D. T. McQuade and P. H. Seeberger, *J. Org. Chem.*, **2013**, *78*, 6384.
80. M. O'Brien, P. Koos, D. L. Browne, and S. V. Ley, *Org. Biomol. Chem.*, **2012**, *10*, 7031.
81. S. V Ley, D. X. Hu, and M. O. Brien, *Org. Lett.*, **2012**, *14*, 4246.
82. M. Küpper, V. Hessel, H. Löwe, W. Stark, J. Kinkel, M. Michel, and H. Schmidt-Traub, *Electrochim. Acta*, **2003**, *48*, 2889.
83. A. Ziogas, G. Kolb, M. O'Connell, A. Attour, F. Lapique, M. Matlosz, and S. Rode, *J. Appl. Electrochem.*, **2009**, *39*, 2297.
84. N. R. Stradiotto, H. Yamanaka, and M. V. B. Zanoni, *J. Braz. Chem. Soc.*, **2003**, *14*, 159.
85. M. Atobe, D. Horii, T. Fuchigami, and F. Marken, *Electrochem. commun.*, **2005**, *7*, 35.
86. H. Lowe and W. Ehrfeld, *Electrochim. Acta*, **1999**, *44*, 3679.
87. A. Attor, S. Rode, A. Ziogas, M. Matlosz, and F. Lapique, *J. Appl. Electrochem.*, **2008**, *38*, 339.
88. R. Horcajada, M. Okajima, S. Suga, and J. Yoshida, *Chem. Commun.*, **2005**, 1303.
89. F. Marken, C. a. Paddon, G. J. Pritchard, and T. Thiemann, *Electrochem. commun.*, **2002**, *4*, 825.
90. S. J. Haswell, P. He, P. Watts, and F. Marken, *Angew. Chemie, Int. Ed. English*, **2006**, *45*, 4146.
91. P. He, P. Watts, F. Marken, and S. J. Haswell, *Lab Chip*, **2007**, *7*, 141.
92. S. J. Haswell, P. He, P. Watts, and F. Marken, *Green Chem.*, **2007**, *9*, 20.
93. S. J. Haswell, P. He, P. Watts, and F. Marken, *Electrochem. commun.*, **2005**, *7*, 918.
94. P. R. Birkin, J. Kuleshova, J. T. Hill-Cousins, R. C. D. Brown, D. Pletcher, and T. J. Underwood, *Electrochim. Acta*, **2011**, *56*, 4322.

95. J. Kuleshova, J. T. Hill-Cousins, P. R. Birkin, R. C. D. Brown, D. Pletcher, and T. J. Underwood, *Electrochim. Acta*, **2012**, *69*, 197.
96. M. Atobe, T. Kashiwagi, F. Amemiya, and T. Fuchigami, *Chem. Commun.*, **2012**, *48*, 2806.
97. G. Roth, R. Stalder, T. Long, D. Sauer, and S. Djuric, *J. Flow Chem.*, **2013**, *3*, 34.
98. S. Waldvogel, T. Fuchigami, M. Atobe, T. Kashiwagi, and B. Elsler, *J. Electrochem. Soc.*, **2013**, *160*, G3058.
99. J. Yoshida and S. Suga, *Chem. - A Eur. J.*, **2002**, *8*, 2651.
100. J.-I. Yoshida, S. Suga, M. Okajima, and K. Fujiwara, *J. Am. Chem. Soc.*, **2001**, *123*, 7941.
101. J. Yoshida, S. Suga, M. Okajima, and K. Fujiwara, *QSAR Comb. Sci.*, **2005**, *24*, 728.
102. J. Yoshida, S. Suga, and A. Nagaki, *Chem. Commun.*, **2003**, 354.
103. S. Suga, A. Nagaki, Y. Tsutsui, and J.-I. Yoshida, *Org. Lett.*, **2003**, *5*, 945.
104. J. Yoshida, A. Nagaki, K. Kawamura, S. Suga, T. Ando, and M. Sawamoto, *J. Am. Chem. Soc.*, **2004**, *126*, 14702.
105. C. Guiducci, Y. Temiz, A. Ferretti, and Y. Leblebici, *Lab Chip*, **2012**, *12*, 4920.
106. H. H. Girault, V. Mengeaud, O. Bagel, R. Ferrigno, and A. Haider, *Lab Chip*, **2002**, *2*, 39.
107. C. Belmont and H. Girault, *J. Appl. Electrochem.*, **1994**, *24*, 719.

Chapter 2

Design and Fabrication of an Electrochemical Microreactor

2.1 Construction and testing of a prototype

After reading through the literature available at the time, work began designing an inexpensive and practical electrochemical microreactor. One thing that stood out as a feature missing from the current microreactors was the ability to dismantle and clean with ease. This was an important feature to be included in the design, because one of the problems that can be encountered with microreactor syntheses is the blocking of the channel.

The current microreactors also had the same rectangular shape in common. A sealed microreactor with a rectangular shape shouldn't cause a problem of uneven pressures across the device, however it was thought that when assembling a rectangular microreactor, an even seal around the outside could be difficult to achieve, so the design brief was to construct a circular device that could be easily dismantled.

With this in hand, construction of a prototype was undertaken. A device that had previously been used to house a chip reactor was developed into an electrochemical microreactor (Figure 2.1). The housing was made from PEEK (polyether ether ketone) and it was fixed together with PEEK screws around the circumference, with inlet and outlet screw ports on the top side.



Figure 2.1: The initial microreactor housing

The most difficult component of the build was the development of the electrodes (Figure 2.2), and a method of connecting the electrode to the power supply. The body of the electrode was formed from stainless steel and the connection was accomplished by tapping a hole into the back of the electrodes so that a screw could be inserted and protrude from the device to be connected to the power supply.



Figure 2.2: The initial electrode design

Once the housing and the base of the electrodes had been built, the electrodes needed to be coated to make the surface suitable for electrolysis. The first method to do this was sputter coating.¹ The simplicity of the process and the availability of the machinery led to a quick completion of the first electrodes.

The process involves a gold/palladium (90/10) target in a vacuum chamber which is then bombarded with heavy argon atoms to displace the metal atoms which are then deposited on the sample surface. This method proved to be ineffective as when initial reactions were undertaken, the pressure of the solution flowing through the reaction channel simply removed the metal coating, and it was deposited in the sample vial where the reaction mixture was collected.

The second method chosen was electroplating. A solution of hexachloroplatinic acid was used as the platinum source, a method reported by Chen *et al.*² The process was tested on a sample piece of stainless steel and SEM (Scanning electron microscopy) images and energy-dispersive X-ray spectroscopy (EDX) plots taken show that before electroplating (Figure 2.3) there is no platinum present on the metal surface. The electroplating procedure was carried out, and as it can be seen in Figure 2.4 the platinum content (2.1 keV) on the surface had increased to more than 36 weight% and was almost equal to the iron content (6.3 keV).

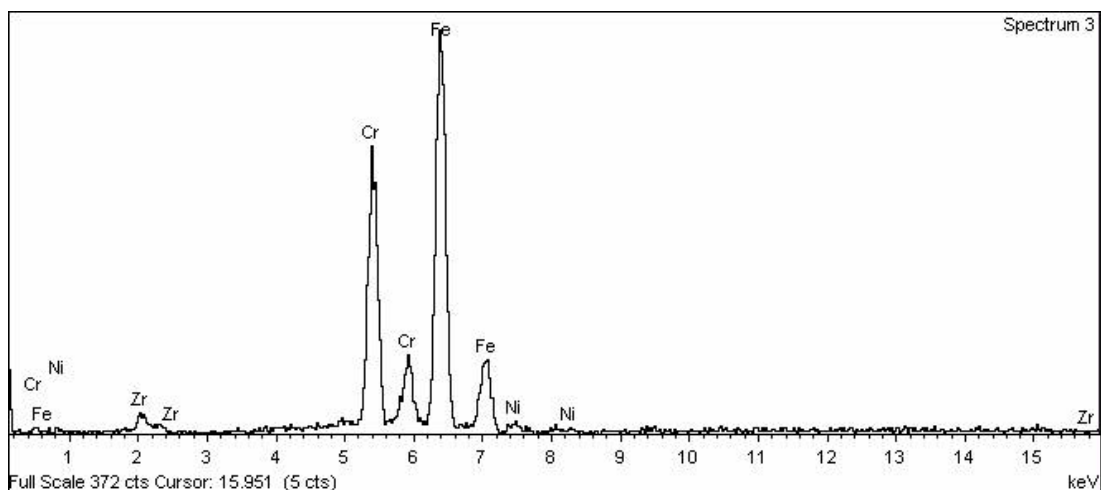

Figure 2.3: EDX image of the electrode surface before electroplating

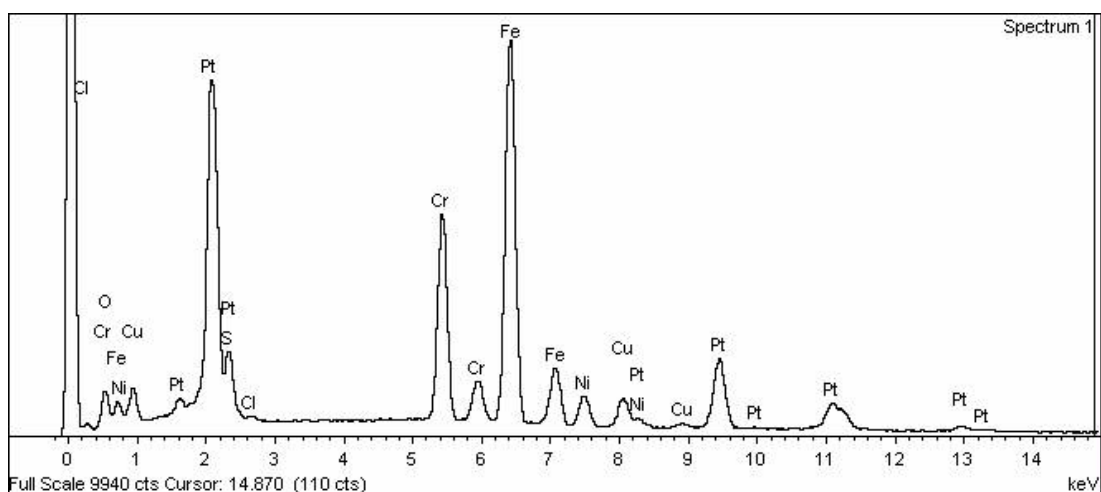

Figure 2.4: EDX image showing a platinum increase on the electrode surface

The actual electrodes were then plated and initial reactions were carried out. Again there was no formation of product, only the blackening of the reaction solution. There also seemed to be an oxidation of the electrode surface, in certain places a brown colour had appeared, most likely due to an incomplete covering of the electrode surface with platinum.

The next idea was the most probable for success, but the cost was greater. A platinum foil (0.1 mm thick, 99.95% from Goodfellow, England) was purchased at a cost of around £200 per electrode. The foil was cut into the shape of the electrode and glued to the surface, conductive glue was not necessary as a tab of platinum was left to protrude out of the device once assembled to be connected to the power

supply (Figure 2.5). Inlet and outlet holes were drilled through the surface of one electrode so that the reaction solution could enter and leave the device.

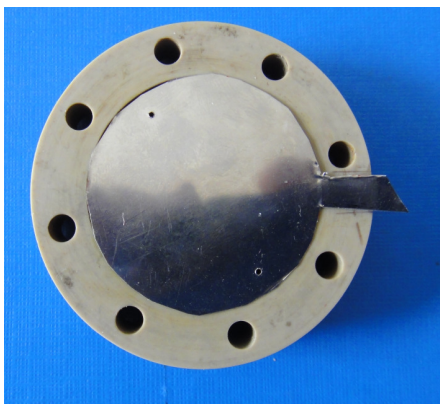

Figure 2.5: The solid foil electrode with connection tab

The reaction channel was formed from FEP (fluorinated ethylene propylene) and a centre channel was cut (3 x 33 mm) for the reaction solution to flow through (Figure 2.6). The channel also acted as a spacer so the electrodes could not make contact with each other, and the first prototype of the electrochemical microreactor was complete (Figure 2.7).

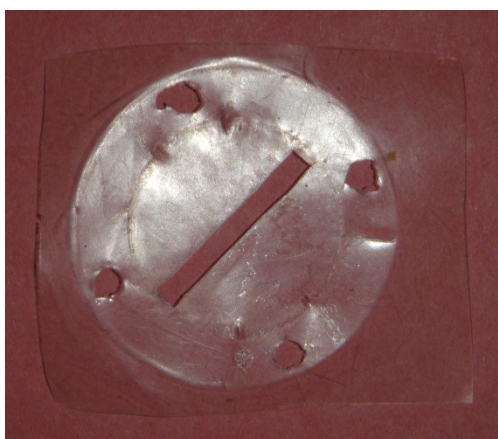

Figure 2.6: FEP spacer and reaction channel

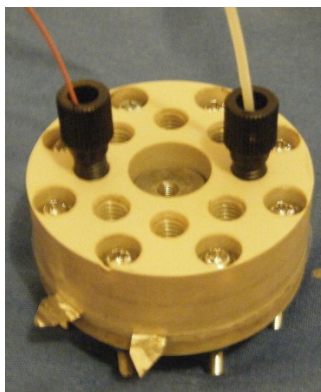
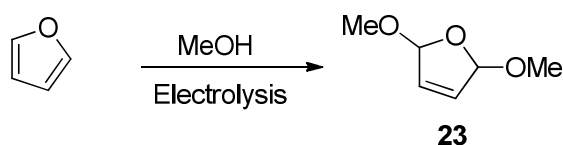

Figure 2.7: The first prototype of the electrochemical microreactor

Initial reactions were then undertaken, and the unsupported methoxylation of furan reported by Atobe *et al.*³ was chosen as a test reaction (Scheme 2.1). The reaction solution entered the device *via* the inlet port connected with a PEEK screw, travelled through the reaction channel and exited the device *via* the outlet port, also connected with a PEEK screw.



Scheme 2.1: The methoxylation of furan

Although a reaction was taking place in the channel, with product being visible from ¹H NMR, the device had major leaking problems. There were a few areas of the device that could be causing the leaking and the first component to be changed was the PEEK screws holding the device together. They were changed for stainless steel nuts and bolts, so a much tighter assembly of the device could be achieved, although now the assembly process was more time consuming.

This did not completely cure the leaking problem so the next solution was to invert the device (from having the inlet/outlet ports on the top, to being on the bottom). A simple solution however effective, because it was thought that the solution leaving the device vertically was causing some back pressure in the device. Again although a reduction in leaking, it was still observed.

The next components investigated were the inlet and outlet ports. Initially the tubing was fixed by the standard method, with the ferrule at the very end of the tubing. It was thought that this could also be causing the device to leak. The solution had to flow from the tubing, through the body of the device, to the electrode surface.

To solve this problem, a thinner external diameter PEEK tubing was purchased (0.8 mm) and the ferrule was connected at a distance of 6 mm from the end of the tubing (Figure 2.8), which would allow the tubing to go through the device to the surface of the electrode, directly into the channel. This was also as a solution in advance as it was thought that after extended use of the reactor, solvent passing from underneath the electrode could after time dissolve the adhesive fixing the electrode foil to the body of the electrode.

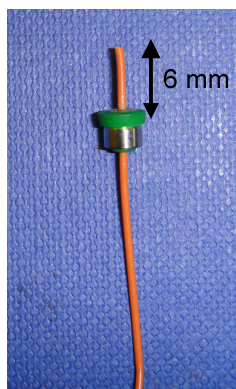

Figure 2.8: Modified inlet and outlet tubing

These improvements had all reduced the leaking of the device, but not completely. Also the assembly method required was a long and awkward process, tightening each of the eight nuts and bolts around the device with an even pressure, a likely additional cause to leaking. This also made it difficult to keep the reactor channel in line with the inlet and outlets holes. If this was the case the reaction solution would enter the device and go beneath the FEP spacer and out of the side of the device.

The next step was to create the second prototype of the device. It was obvious that the new device should have a metal body so adequate pressure could be applied to stop the device leaking. This of course meant that the electrodes had to be redesigned to not be in contact with the metal body of the reactor. It should also be possible to assemble and take the device apart. This was so that if blockages occurred during

synthesis the device could be cleaned. A simple assembly method would also allow the device to be assembled much quicker than the previous prototype.

The material chosen for the new device was aluminium, a soft, ductile metal. An easy method to achieve a fast assembly was that one side of the microreactor body, part A (Figure 2.9), should have the nuts fixed into it permanently, while on the other side the inlet and outlet port holes would be tapped for the PEEK screws to be connected. This then would allow for the second half of the device to simply slot onto the protruding studs to be secured in place. However instead of standard hexagon nuts, wing nuts were chosen so the tightening process was quick and simple. On the inside of part A, the inlet and outlet holes should have a rubber O ring, this is to ensure that a tight seal around the inlet and outlet holes on the underside of the electrode to avoid leaking.

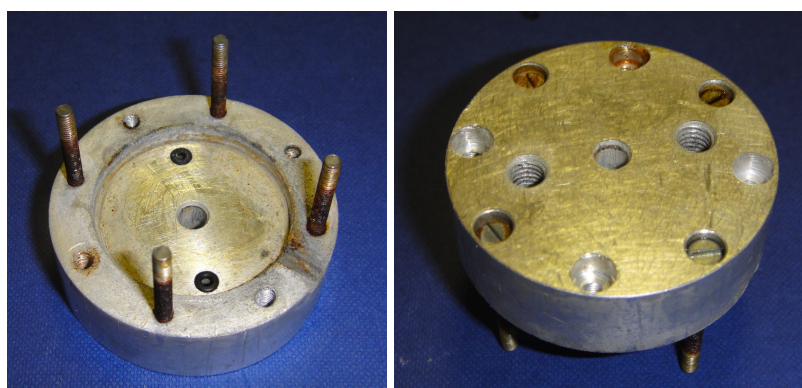

Figure 2.9: Part A of the microreactor

Part B of the device (Figure 2.10) is simply to hold the second electrode and to slot onto the bolts contained within part A. The holes within the centre of both parts A and B are for convenience. If for some reason the electrode becomes stuck in the device, they can be removed by pushing them out through the central holes. The groove that can be seen on the right hand side of part B, Figure 2.10, also present on part A, is to allow the wire connecting the electrode to exit the device and connect to the power supply.



Figure 2.10: Part B of the microreactor

As previously mentioned, the new aluminium body for the device required electrode bodies that were not made from metal, so when current was applied to the device only the electrodes received the current, not the entire body of the device. To accomplish this, new electrode bodies were made from PTFE (polytetrafluoroethylene) (Figure 2.11). Each electrode disc was cut 1 mm thicker than the depth of the electrode compartment so that the surface was not flush with the outer ring of the reactor body. This was to ensure an even pressure could be applied to the device and the electrode would not be pushed deeper into the electrode compartment. If this was the case, it would relieve the pressure on the channel, ultimately causing the reactor to leak.

The connection of the electrode surface was accomplished by drilling a small hole through the PTFE body so that a wire could be glued into place. If any glue was covering the topside of the wire then this was removed before the platinum foil was glued on top (again making sure that there is no adhesive covering the wire). Once the platinum foil was glued into place the wire was secure, and the electrode could be placed into the reactor body, orientated with the wire in the groove on the outside of the housing. The non-conductive coating on the wire made sure that there was no wire touching any of the metal housing to cause a short-circuit.



Figure 2.11: The PTFE constructed electrodes

The second prototype of the electrochemical microreactor was now complete (Figure 2.12). A schematic representation, complete with dimensions can be found in the appendices of this thesis, and a computer generated three dimensional image can be found at the end of this chapter, along with general assembly instructions in the Experimental section 2.3.

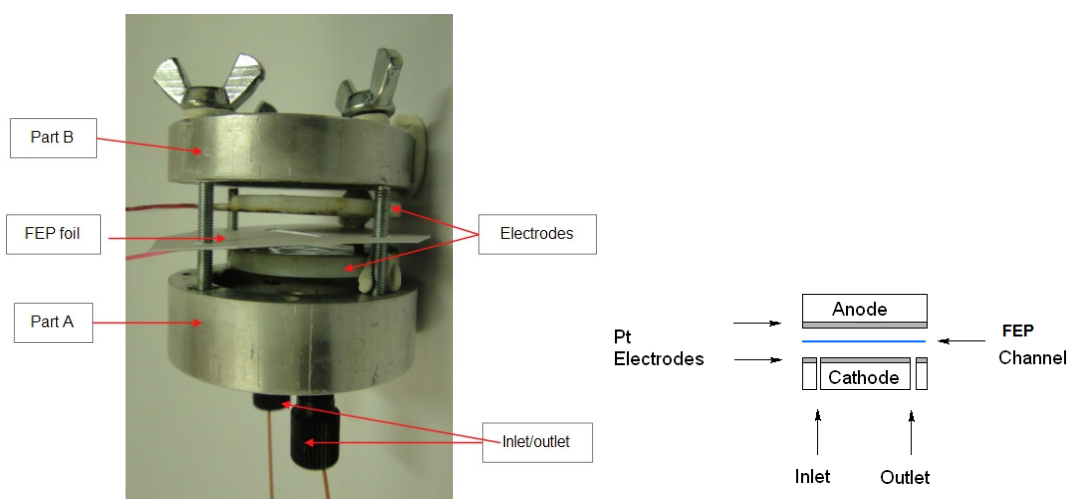

Figure 2.12: An exploded photograph of the device and a schematic representation

Now a complete working electrochemical microreactor device had been designed and fabricated, chemical reactions were undertaken to test that it functioned correctly. The first test reaction (Scheme 2.1) was chosen as it had already been proven a successful electrochemical reaction in flow,³ and although the authors get a lower yield when using platinum electrodes instead of carbon electrodes, the synthesis was still successful and would be a good test for the microreactor.

The methoxylation of furan is a very clean reaction, no additional reagents are necessary: furan is dissolved in methanol and electrolysis gives **23**. The work-up is also very simple because once the solvent has been removed, along with the starting material due to its low boiling point (31 °C), **23** remains in the flask with nothing further to be done.

After varying flow rates and current densities, once **23** became visible on TLC a full reaction was run (10 ml) with a channel thickness of 0.1 mm (reactor volume 9 μ L) and a maximum yield of 41% was achieved. Atobe *et al.*³ achieved higher yields when using a combination of carbon and platinum electrodes, with their lowest yield from two platinum electrodes (See experimental section 2.3).

A second test reaction was then carried out, the Kolbe dimerisation of carboxylic acids reported by Wilshire in an anhydrous solvent.⁴ Kolbe electrolysis had also been reported on an industrial scale in a flow reactor.⁵ The reaction chosen was the Kolbe dimerisation of phenylacetic acid **24a** and diphenylacetic acid **24b**.

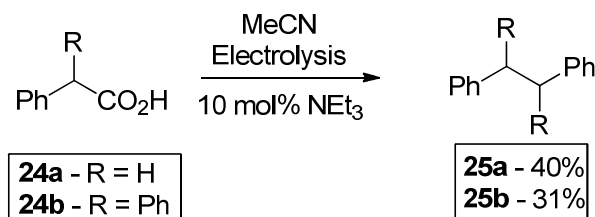

Scheme 2.2: Kolbe dimerisation of carboxylic acids

The reaction did not seem to be a suitable candidate for a flow system because of the evolution of CO₂ but this was overcome by the addition of triethylamine to partially neutralise the solution and stop the evolution of carbon dioxide.⁵ A back pressure regulator could not be used in this case as when connected to the outlet, the device began to leak as a result of pressure build up inside the device. It was necessary to use triethylamine and not sodium hydroxide in the reaction, as when initial reactions were undertaken, a tarnishing of the electrode surface took place, and it was necessary to polish the surface before another reaction could be run. Tarnishing was also observed when inorganic salts such as KF were used as a supporting electrolytes, but organic liquid bases such as triethylamine did not tarnish the electrode surface. After a series of reactions were tried to verify the formation of the

products, reactions were undertaken to record isolated yields for the compounds, and were found to be higher than that achieved by Wilshire for **25a** with the same solvent and base (18 %),⁴ and comparable to that achieved by Rand *et al.* with DMF as the solvent (**25a** 59%, **25b** 36%).⁶

2.2 Conclusions

The functioning electrochemical microreactor, having a simple and quick assembly method, with the ability to dismantle and clean the device as necessary had been designed and fabricated. Its ability to carry out known electrochemical reactions, already reported in a flow environment, has been tested and its ability as an electrochemical microreactor verified. The ability to dismantle the device also allows for the future development of the device by using electrodes of different material.

Attempts were made to increase the channel length within the microreactor to make full use of the electrode surface area (Figure 2.13). However this was ineffective as the structural integrity of the FEP was not able to keep the shape, and the solution would not flow through the device effectively.

Another issue with the device was that when using the 0.1 or 0.12 mm thick FEP foils if too much pressure was applied when assembling the device, or uneven pressure around the device, the electrode faces became too close and could touch resulting in a short circuit. To overcome this in future only a channel of thickness 0.25 mm was used.

It is also important to mention safety issues. Before electrolysis was carried out the circuit was tested with a multimeter to make sure that no current was flowing through the system. If the circuit was complete without the reaction solution in the device then touching the metal body could result in an electric shock. Also if leaking is observed then it is important to turn off the electricity supply before touching the device as the body of the device will be conducting electricity. The power supply also has a safety feature and will stop supplying electricity to the circuit if a short circuit is detected.

Another development that could be made to vary the type of electrochemical reactions possible in the device, is that it could be converted into a divided cell if

inlet and outlet holes were placed in part B of the device.⁷ The channel would also have to be changed by having a porous membrane sandwiched in between two of the current FEP channels.

Although the device functioned well, for long term use, the second prototype would need some development to the method of connecting the electrode to the power supply. The current method requires occasional rebuilding of the electrodes, as the thin wire becomes fragile and can break off after continual usage. There is also some room for improvement that could be made to the tapped holes to connect the inlet and outlet tubing, possibly a better method for sealing as occasional leaking can occur from this area of the device.

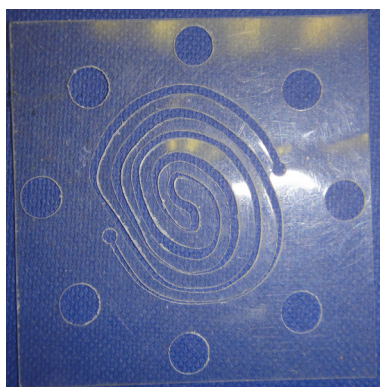

Figure 2.13: An ineffective lengthening of the reaction channel

2.3 Experimental

General assembly procedure

1. Take part A of the device, place the O rings into position at the inlet and outlet holes.
2. Insert the corresponding electrode into part A. (A hypodermic needle (diameter 0.08 mm) can be used to align the inlet and outlet holes).
3. Take the FEP channel and align the channel and screw holes to the correct position.
4. Take part B of the device and insert the corresponding electrode.
5. Place part B onto the screws of part A.
6. Clamp the device shut with the wing nuts, finger tight with an even pressure.
7. Invert the device and insert the inlet and outlet tubing and screw into position tightly.
8. Hold the device in a clamp stand with the tubing facing down.
9. Place the reaction solution into a syringe and connect the inlet tubing with a luer lock.
10. Connect the power supply to the electrodes and before the reaction is started, confirm that no current is flowing through the circuit when there is no solution in the channel.
11. Start the syringe pump and wait until the reaction solution has reached the outlet tube before applying the desired current to the circuit with the galvanostat in constant current mode.
12. Wait until the reaction has reacted equilibrium (the residence time of the reaction).
13. Place collection vial under the outlet to collect the product.

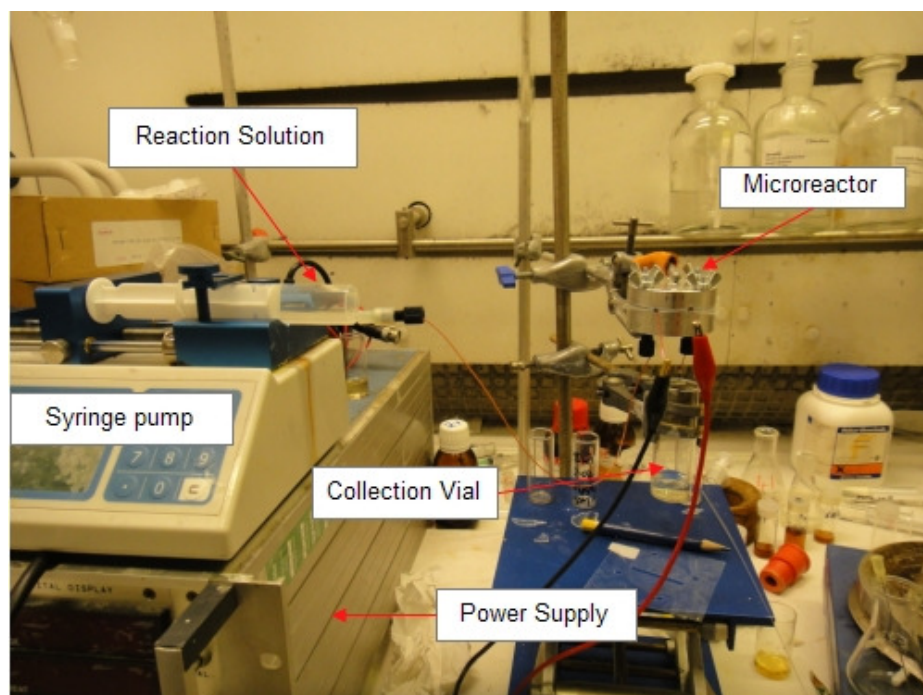
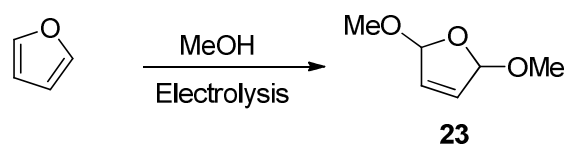

Figure 2.14: Photograph of the general microreactor set-up

Furan oxidation



A 0.05 M solution of furan in methanol (10 ml) was made and introduced into the electrochemical microreactor (channel dimensions 3 x 30 x 0.1 mm, channel volume 9 μL) *via* a syringe pump (flow rate 80 $\mu\text{L min}^{-1}$, residence time 7 seconds) with an applied current of 2 mA cm^{-2} . The reaction was allowed to reach equilibrium and the solution was collected at the outlet to give a mixture of *cis* and *trans* (2:1) **23** with a yield of 41% after the removal of the solvent and furan *in vacuo*. The product was identified by GCMS (m/z (EI): M^+ 129.1).

2,5-Dimethoxy-2,5-dihydrofuran **23**³ (9.7 ml collected in 120 mins to give 26 mg, 41%)

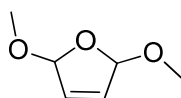

Colourless oil; ¹H NMR (400MHz, CDCl₃): δ = 3.37 (s, 6H, 2 x CH₃), 3.39 (s, 6H, 2 x CH₃), 5.59 (s, 2H, 2 x CH), 5.87 (s, 2H, 2 x CH), 6.03 (s, 2H, 2 x CH), 6.04 (s, 2H, 2 x CH) ppm; ¹³C NMR (100 MHz, CDCl₃): δ = 55.0 (2 x CH₃), 106.4 (2 x CH), 106.9 (2 x CH), 131.1 (2 x C=C), 131.6 (2 x C=C) ppm; GCMS (*m/z* (EI): M⁺ 129.1), 99.1 (100, M – CH₃O), 71.1 (71, M – 2 x CH₃O).

Kolbe electrolysis

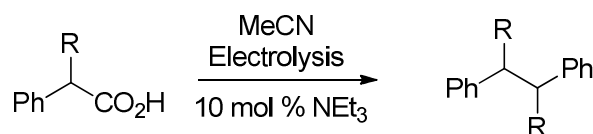

A 0.1 M solution of **24a** / **24b** dissolved in acetonitrile (10 ml) with 0.01 M triethylamine was introduced into the electrochemical microreactor (channel dimensions 3 x 30 x 0.12 mm, reactor volume 11 μL) *via* a syringe pump (flow rate 40 μL min⁻¹, residence time 17 seconds) with an applied current of 4 mA cm⁻². The reaction was allowed to reach equilibrium before collecting the solution at the outlet to give **25a** (40%) **25b** (31%) after column chromatography (SiO₂, hexane - ethyl acetate).

1,2-Diphenylethane **25a**⁶ (9.6 ml collected in 240 mins to give 70 mg, 40%)

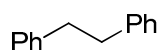

White solid m.p.: 50 - 51 °C (lit. 53 °C), ¹H NMR (250 MHz, CDCl₃): δ = 2.98 (s, 4H, 2 x CH₂), 7.23 – 7.39 (m, 10 H) ppm; ¹³C NMR (62 MHz, CDCl₃): δ = 37.9 (2 x CH₂), 125.8 (2 x CH_{Ar}), 128.3 (4 x CH_{Ar}), 128.4 (4 x CH_{Ar}), 141.7 ppm (2 x C_{Ar}).

1,1,2,2-Tetraphenylethane **25b**⁶ (9.3 ml collected in 3.8 hours to give 96 mg, 31%)

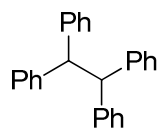

White solid m.p.: 209 – 211 °C (lit. 214 °C), ¹H NMR (400 MHz, CDCl₃): δ = 4.78 (s, 2H, 2 x CH), 7.00 – 7.18 (m, 20 H) ppm; ¹³C NMR (100 MHz, CDCl₃): δ = 56.3 (2 x CH), 125.8 (4 x CH_{Ar}), 128.1 (8 x CH_{Ar}), 128.4 (8 x CH_{Ar}), 143.4 (4 x C_{Ar}) ppm.

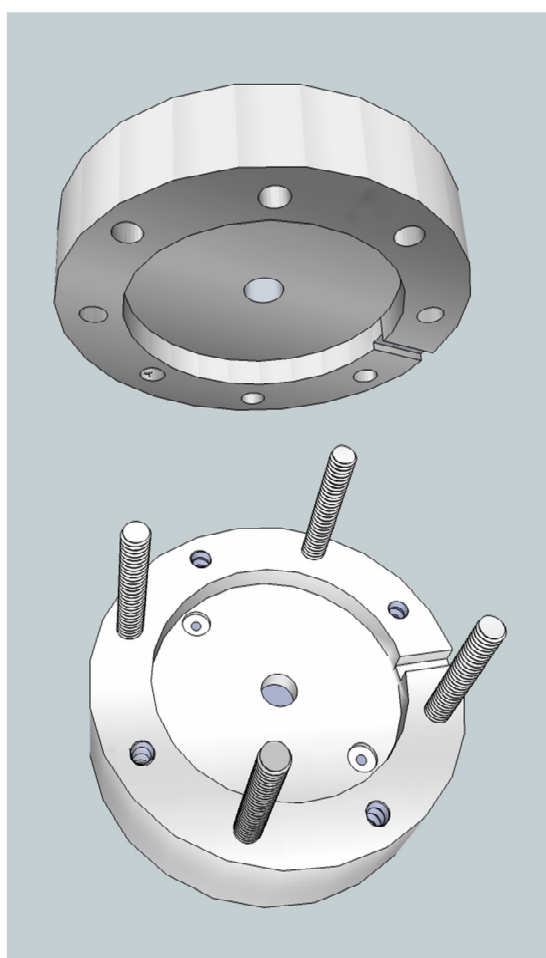

A three dimensional computer generated image to show how the device fits together

2.4 References

1. D. Mattox, *The foundations of vacuum coating technology*, William Andrew Publishing, 1st Edn., 2003.

2. C.-M. Chen, C.-H. Chen, and T.-C. Wei, *Electrochim. Acta*, **2010**, *55*, 1687.
3. M. Atobe, D. Horii, T. Fuchigami, and F. Marken, *Electrochem. commun.*, **2005**, *7*, 35.
4. J. Wilshire, *Aust. J. Chem.*, **1963**, *16*, 432.
5. F. Beck, J. Haufe, and H. Nohe, 1974, U.S. Patent 3,787,299, Jan 22, 1974.
6. L. Rand and A. Mohar, *J. Org. Chem.*, **1965**, *30*, 3885.
7. R. Horcajada, M. Okajima, S. Suga, and J. Yoshida, *Chem. Commun.*, **2005**, 1303.

Chapter 3

Electrochemical Synthesis of Diaryliodonium Salts in Flow

3.1 Introduction

Since the beginning of the 21st century the organic chemistry of hypervalent iodine compounds has received a great amount of attention. This is because the use of transition metals in organic synthesis suffers from drawbacks such as toxicity and high costs. Hypervalent iodine compounds are now widely used in organic synthesis as efficient alternatives to toxic heavy-metal-based oxidants and expensive metallic catalysts for many organic transformations. The increasing importance and significance of hypervalent iodine compounds can be attributed to factors such as:¹⁻⁴

- Hypervalent iodine compounds can be made readily from inexpensive commercial precursors like PhICl_2 , $\text{PhI}(\text{OAc})_2$ and $\text{PhI}(\text{OH})\text{OTs}$.
- Hypervalent iodine compounds tend to be selective in their reactions and generally can be used under mild reaction conditions.
- Iodine (III) reagents with two carbon ligands have properties resembling those of Hg, Pb, and Pd complexes and can be used in reactions pathways similar to that of metal-catalysed reactions.
- Iodine (III) reagents with two heteroatom ligands such as (diacetoxyiodo)benzene (PIDA) and iodosylbenzene (Scheme 3.1) are employed in oxidations of alcohols and alkenes as well as the α -functionalisation of carbonyl compounds.

This chapter will focus on iodine (III) reagents but it is not only these hypervalent iodine compounds that have found use in organic synthesis. Iodine (V) reagents include compounds such as Dess-Martin periodinane and IBX (Figure 3.1) are frequently used as mild oxidants of alcohol moieties.¹

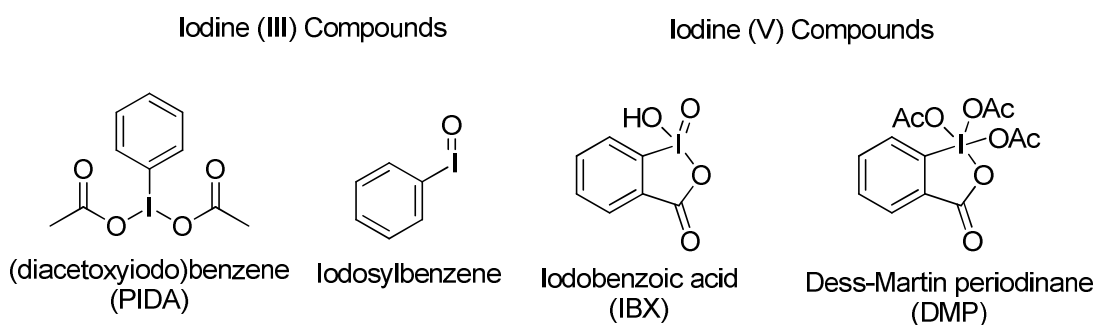

Figure 3.1: Common hypervalent iodine compounds

Diaryliodonium salts have been known since 1894 and are air- and moisture-stable compounds.² They are the most investigated compounds among iodonium salts and a recent review published by Olofsson *et al.*¹ covers their syntheses and applications in organic chemistry. They are still referred to as the old term iodonium salts but the IUPAC nomenclature for the class of compounds is “diaryl- λ^3 -iodanes”.¹⁻³

The structure of diaryliodonium salts consists of two aryl moieties bonded to an iodine centre, and a counter ion (Figure 3.2 a). The counter ion can vary from halides to triflates and tetrafluoroborates, the former having poor solubility in many organic solvents, while the latter have better solubility and another attractive property, the counter ion is weakly coordinating, or non-nucleophilic. This makes them easily applicable to organic syntheses as the counter ion will not interfere with the desired reaction.¹

The term “salt” is not completely accurate, X-ray structures of iodine (III) compounds show a T-shaped molecule (Figure 3.2 b). However in solution, most iodonium salts are considered to be purely ionic, *e.g.* $\text{Ar}_2\text{I}^+ \text{BF}_4^-$, where no hypervalent bonding exists, however iodine (III) molecules with two heteroatom ligands are believed to retain this T-shape in solution. Diaryliodonium salts structure in solution has been debated and is said to depend on both the anion and the solvent.^{1,2,4}

Iodine (III) compounds are electrophilic at iodine because of the node in the nonbonding orbital of the hypervalent bond (Figure 3.2 c) hence they can react with various nucleophiles *via* initial nucleophile-iodine bond formation and release of one of the ligands (Scheme 3.1 a) followed by nucleophilic substitution by the free ligand or reductive elimination to give the product and the corresponding aryl iodide.¹ They serve as versatile arylating agents with a variety of nucleophiles due to their highly electron deficient nature and excellent leaving group ability, said to be 10^6 times greater than that of triflates.⁵ In metal catalysed reactions iodonium salts behave as more reactive versions of aryl iodides, giving an aryl moiety and a ligand to the metal centre in an oxidative addition (Scheme 3.1 b). The aryl metal complex will then react further to give cross-coupling products.¹

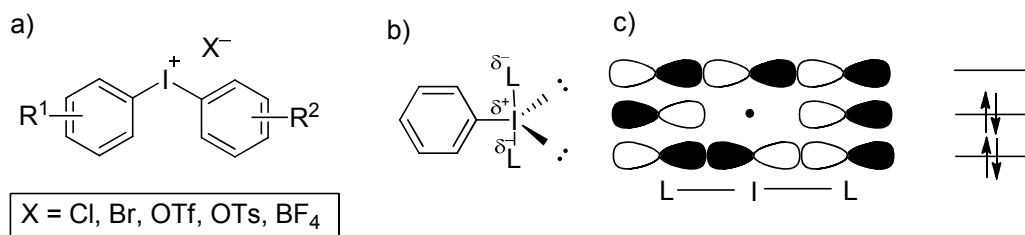
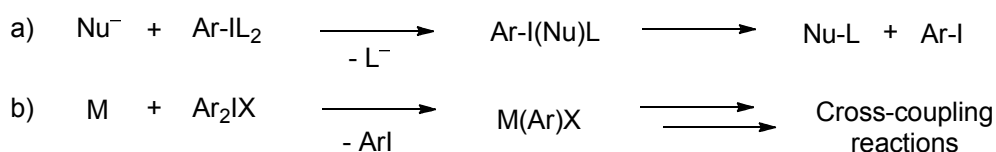

Figure 3.2: a) General structure of iodonium salts, b) Shape determined by X-ray structure analysis, c) orbitals in the hypervalent bond¹



Scheme 3.1: General reactivity of iodine (III) compounds in a) reactions with nucleophiles, b) metal-catalysed reactions¹

Diaryliodonium salts can be in two forms, symmetrical, where $R^1 = R^2$, and unsymmetrical salts where $R^1 \neq R^2$. The former are generally preferred as there are no selectivity issues in aryl-transfer reactions. However unsymmetric salts are preferred when the starting materials are expensive. In this case one aryl moiety can be transferred while the other acts as a “dummy ligand”. Generally the more electron deficient aryl moiety will be transferred in enolate and heteroatom arylations, whereas the more electron rich aryl group will be transferred in cross-coupling reactions. The properties of these unsymmetric salts can also be more easily varied making them beneficial for certain applications.^{1,2}

3.1.1 Synthetic routes to diaryliodonium salts

The most common way of synthesising diaryliodonium salts is a stepwise approach in which an aryl iodide is converted into an aryl diiodide (III) compound by treatment with an inorganic oxidant under acidic conditions. The aryl diiodide (III) compound can then be isolated and subsequent ligand exchange will give the diaryliodonium compound. The anion generally originates from the acid used in the reaction and an anion exchange can be performed to give a more easily isolated or applicable salt (Scheme 3.2 a). Shorter synthetic routes can be achieved when using preformed inorganic iodine (III) reagents (Scheme 3.2 b). The drawback of this method being

that the inorganic iodine reagents must be prepared beforehand and not all are stable enough to be stored. There are now also many one-pot procedures available to achieve diaryliodonium salts directly, either directly from arenes and iodoarenes or molecular iodine in the presence of an oxidant under acidic conditions (Scheme 3.2 c + d). A common feature of most synthetic routes is the electrophilic aromatic substitution of an arene onto an iodine (III) intermediate.¹

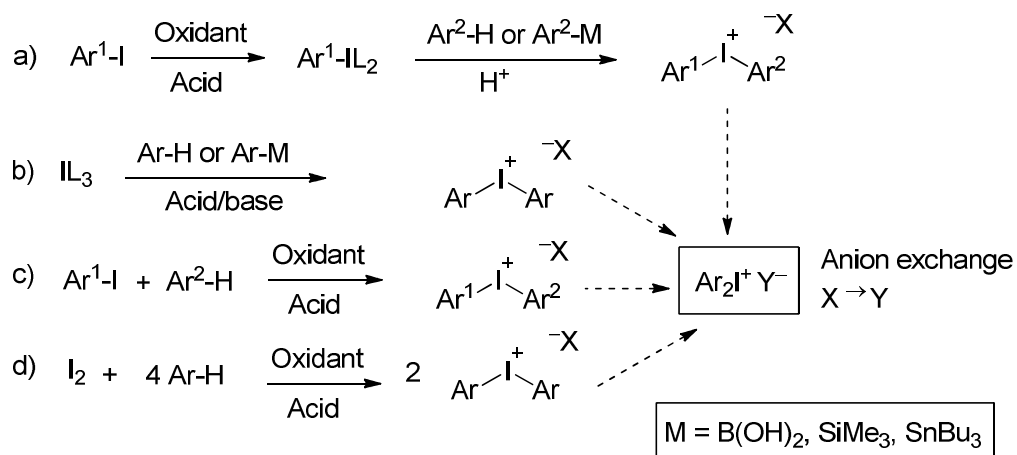

Scheme 3.2: General synthetic routes to diaryliodonium salts¹

The first synthesis of diaryliodonium salts was reported in 1894 by Hartmann and Meyer,⁶ and early synthetic routes involved the condensation of preformed hypervalent iodine compounds such as iodosylbenzene, however these reactions were time-consuming and low yielding.

Beringer *et al.*^{7,8} published a large number of routes in the 1950's with their method of treating arenes with a range of hypervalent iodine reagents such as iodosylarenes, (diacetoxyiodo)arenes and iodoxyarenes. They were able to synthesise symmetrical and unsymmetrical iodonium salts in the presence of acids (Scheme 3.3). It was found that the electronic properties of the arene influenced the reactivity and yields considerably, with electron deficient substituents needing sulphuric acid, while acetic anhydride/trifluoroacetic acid were efficient for electron-rich arenes.

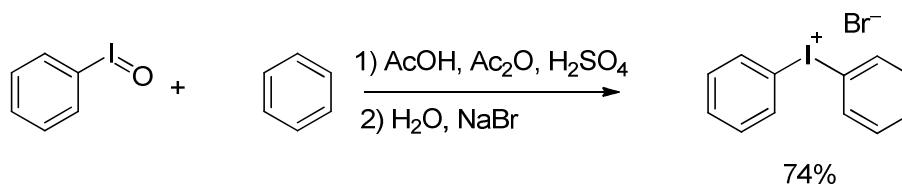
Scheme 3.3: Beringer *et al.* route to diaryliodonium salts

The first regiospecific synthesis of diaryliodonium tosylates was discovered by Koser *et al.*⁹ The reaction of hydroxyl(tosyloxy)iodobenzene (PhI(OH)OTs – Koser’s reagent, **26**) with arylsilanes under neutral conditions (Scheme 3.4). When Koser’s reagent **26** was heated with (trimethylsilyl)benzene in acetonitrile near reflux for four hours, diphenyliodonium tosylate was obtained in 46% yield after work-up. Reactions with *o*-, *m*-, and *p*-(trimethylsilyl)benzenes also gave the corresponding iodonium salts in 29 – 63% yields. Koser’s reagent **26** was also found to be able to react directly with anisole and other electron rich arenes such as thiophene without the need for the TMS activating group to give the corresponding iodonium tosylates.^{1,9}

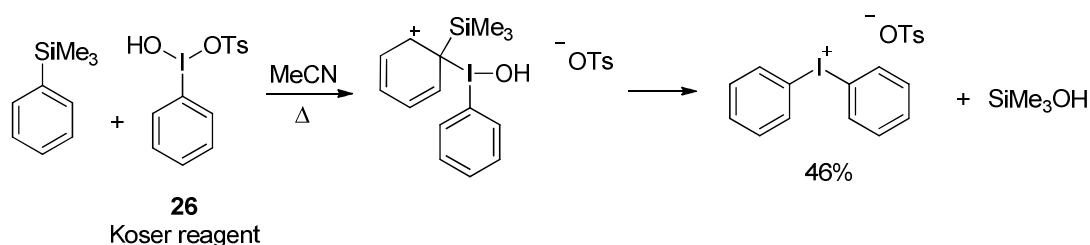

Scheme 3.4: Koser’s synthesis of diaryliodonium triflates

The research groups of Kitamura and Oloffson have independently developed one-pot syntheses of diaryliodonium salts. Kitamura *et al.*¹⁰ developed an easy and efficient preparation of diaryliodonium triflates from iodoarenes (Scheme 3.5). Firstly diaryliodonium trifluoroacetoxylates were prepared by the reaction of iodoarenes with trifluoroacetic acid, and potassium peroxodisulfate ($K_2S_2O_8$) as the oxidant when using aromatic substrates, after which the interaction of the $Ar_2I^+(OCOCF_3)^-$ with sodium triflate solution provided the corresponding diaryliodonium triflates, at room temperature and in good yields. The method was limited to electron deficient aryl iodides and alkylarenes, and iodoarenes and for arenes with strong electron donating groups the method was unsuccessful.

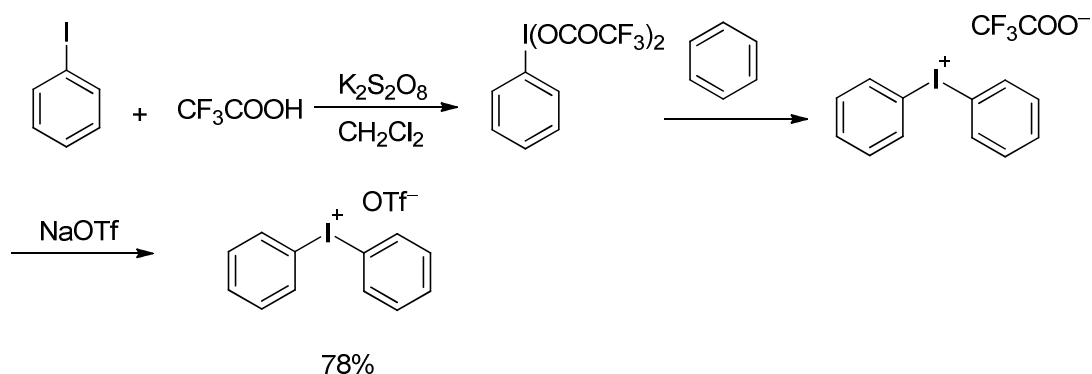
Scheme 3.5: Kitamura *et al.* one-pot procedure for diaryliodonium triflates

Oloffson *et al.*¹¹ have reported the one-pot procedure for diaryliodonium triflates from aryl iodides and arenes using *m*-CPBA as the oxidant (Scheme 3.6). The general procedure was applicable to both symmetrical and unsymmetrical salts with varying electronic properties, and was found to be successful with both electron donating and withdrawing substrates including heteroaryl substituents.

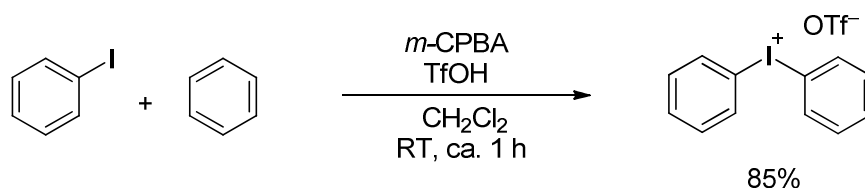
Scheme 3.6: Oloffson *et al.* one-pot procedure for diaryliodonium triflates

3.1.2 Applications of diaryliodonium salts

Some of the most important and synthetically useful reactions of diaryliodonium salts include the direct electrophilic arylations of various nucleophiles, transition metal mediated cross-coupling reactions and reactions involving the generation and trapping of benzyne intermediates. There have also recently been encouraging advances in asymmetric synthesis.

Due to their highly electron-deficient nature and hyper leaving group ability diaryliodonium salts have a predominant use as arylation reagents. The first reported asymmetric α -arylation using diaryliodonium salts was by Ochiai *et al.*¹² for the synthesis of 1,1'-binphthyl-2-yl(phenyl) iodonium salts (Scheme 3.7a) and their use for α -phenylation of β -keto esters (Scheme 3.7b). The chiral salts were synthesised

via BF_3 – catalysed tin- λ^3 -iodane exchange and they were able to achieve direct α -phenylation of enolate anions derived from cyclic β -keto esters. This is the first report using an iodonium salt as the source in asymmetric induction. Moderate yields and enantioselectivities were achieved.

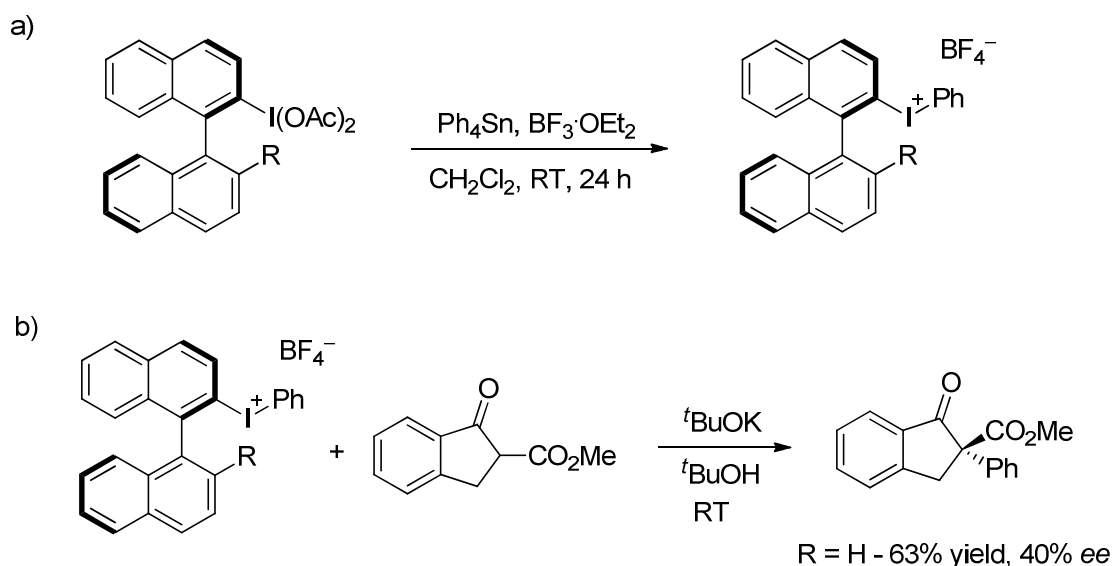

Scheme 3.7: a) Synthesis of chiral iodonium salts, b) asymmetric α -phenylation using chiral iodonium salts

In a second example from Aggarwal *et al.*¹³ the direct α -arylation of cyclohexanones was developed (Scheme 3.8). Using a chiral base they were able to couple iodonium salts with substituted cyclohexanones after enantioselective deprotonation. This gave the desired 2-aryl ketones in moderate yields with high enantioselectivities. This strategy was then furthered and applied to a total synthesis of (-)-epibatidine.

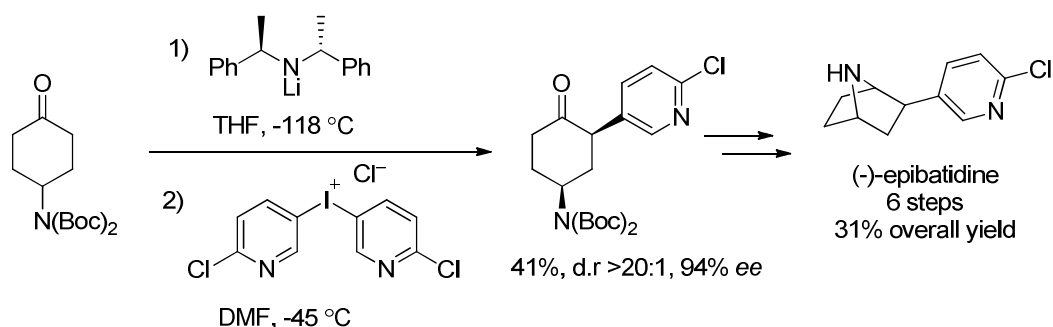

Scheme 3.8: Asymmetric α -arylation using a chiral base

In recent years diaryliodonium salts have been frequently applied in metal catalysed reactions, resulting in new and unique reaction pathways. One such example

reported by Zhu *et al.*¹⁴ showed that Heck reactions can be performed in less than one minute with microwave irradiation when using diaryliodonium salts under aqueous conditions. The process was used to prepare a number of *trans*-cinnamic acids and *trans*-cinnamyl alcohols in excellent yields (Scheme 3.9).

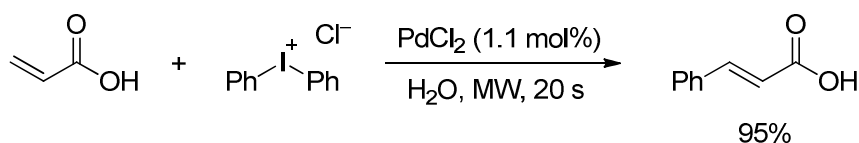

Scheme 3.9: Heck reaction under microwave irradiation with iodonium salts

Sanford *et al.*¹⁵ developed a palladium catalysed method for the direct 2-arylation of indoles. The reactions took place under remarkably mild conditions, often being at room temperature, and were even compatible with N-H free indoles with no competing *N*-arylation reaction. The synthetic utility of the reactions was also enhanced by the high selectivity for arylation at C-2 and also by the ability to generate active arylating reagents *in situ* from the corresponding (diacetoxyiodo)arene and arylboronic acid (Scheme 3.10).

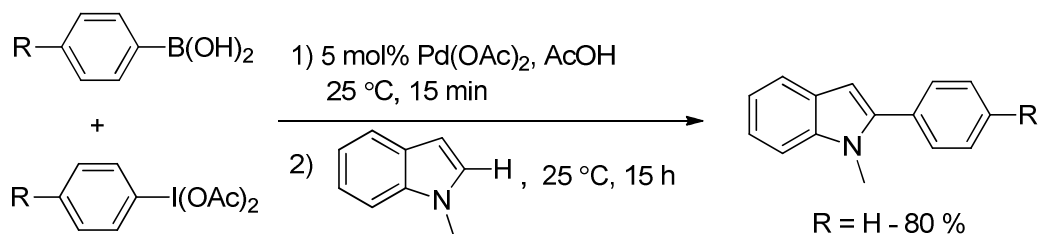

Scheme 3.10: Selective arylation of indoles with *in situ* generation of iodonium species

Kitamura *et al.* developed a mild and efficient benzyne precursor that can be synthesised on a multigram scale that is crystalline, air stable, non-hygroscopic and can be used at room temperature.¹⁶⁻¹⁸ (Phenyl)[2-trimethylsilyl]phenyliodonium triflate **27** is prepared in two steps and easily purified. Addition of a fluoride source, such as tetrabutylammonium fluoride, to **27** liberates the aryne, which can then be trapped, and its efficiency is demonstrated by trapping with furan to give the desired product with a quantitative yield (Scheme 3.11). The authors were then able to further the scope of the reaction to functionalised benzyne, especially benzyne with

ketone or acyl functionalities with high yields.¹⁹ This approach was also used by Xue *et al.*²⁰ in the *o*-arylation of a range of carboxylic acids and sulfonic acids.

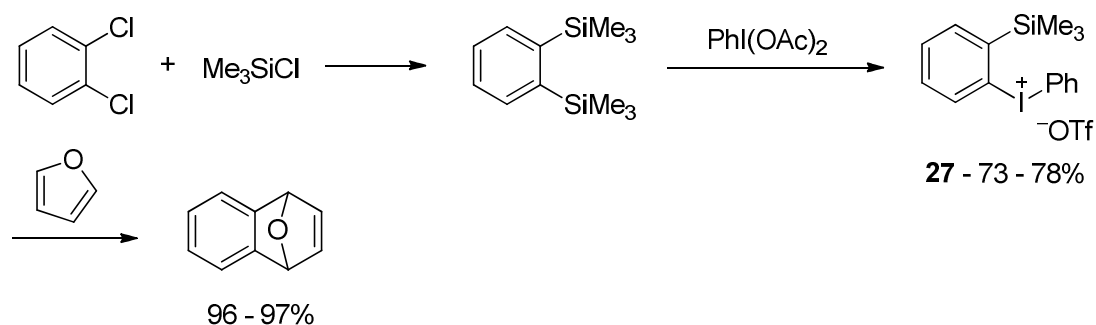

Scheme 3.11: Generation and trapping of benzyne intermediates with iodonium salts

3.1.3 Electrosynthesis of diaryliodonium salts

Miller *et al.*²¹ reported the electrochemical oxidation of organic iodides at platinum electrodes in acetonitrile solutions containing lithium perchlorate to produce diaryliodonium salts. When using aryl iodides, it was found that unlike alkyl iodides, which undergo carbon-iodine bond scission they were found to couple. While oxidising only iodobenzene, the major product was found to be 4-iododiphenyliodonium perchlorate (**28**), they were able to change the major product formed during the reaction by adding an excess of benzene to the reaction solution, which gave them the product diphenyliodonium perchlorate **29**.

The authors go on to describe the mechanism explaining the products that they were able to isolate (Scheme 3.12). Initially, the iodobenzene cation radical formed electrochemically is attacked by a molecule iodobenzene/benzene to form the radical cation **30**, which then decomposes to product by the formal loss of a proton and an electron. The fact that when benzene is present in the reaction, compound **29** is formed supports the proposed mechanism.

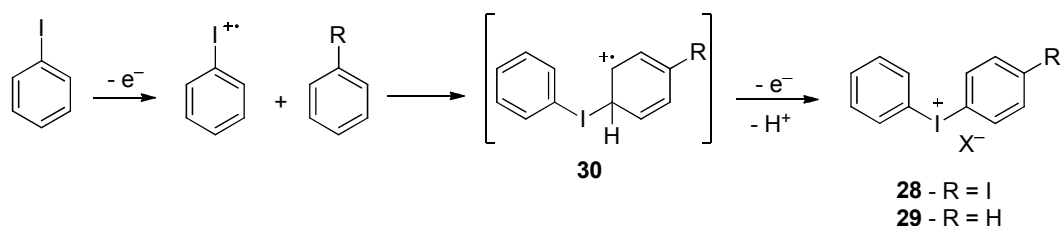

Scheme 3.12: Mechanism for the electrochemical formation of diaryliodonium salts

Later Hoffelner *et al.*²² investigating the mechanism of the reaction (Scheme 3.12) reported that it was only on platinum electrodes in acetonitrile solution that the conditions are so favourable, that the self-coupling of iodobenzene to **28** can be avoided. They also report that optimal conditions, based on electrode kinetic investigations, should be a low working temperature, low working potential, and a high iodobenzene to benzene ratio in the bulk of the solution.

3.2 Results and discussion

It was from a publication by Pletcher *et al.*²³ that work on creating diaryliodonium salts in flow began. The authors were able to synthesise a number of symmetrical and unsymmetrical salts with yields from 48 to 92% in batch (Scheme 3.13). The scope of the reaction was however limited to aryl substrates and aryl iodides bearing only alkyl substituents. When electron withdrawing groups were present no coupling product was observed, and when activated arenes, such as anisole were used, the substrate underwent spontaneous sulfonation within a few minutes.

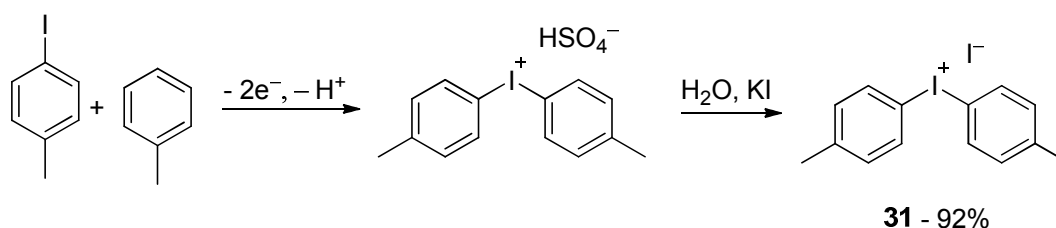

Scheme 3.13: Pletcher *et al.* scheme for electrochemical iodonium salt formation

Our initial attempt to create suitable flow conditions began with toluene and iodotoluene as a model reaction. The solvent system used in the initial reactions was acetonitrile containing 2 M H_2SO_4 . A large excess of acid was used as it was not only acting as the supporting electrolyte carrying charge through the system, but also as the counter ion to the initial iodonium salt formation. Acetic anhydride was also present in the reaction as it was said to increase the selectivity of the reaction and to stop the formation of the iodobenzyl acetate side product.

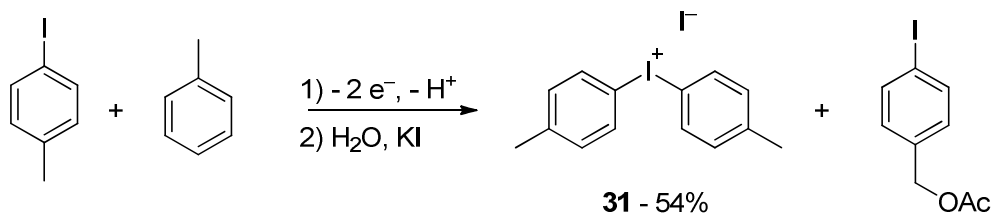

Scheme 3.14: The formation of **31** and 4-iodobenzyl acetate side product with 10 % volume acetic anhydride

Entry	Acetic anhydride (% vol)	Yield 31 (%)
1	10	54
2	25	72

0.1 M 4-iodotoluene, 0.3 M toluene, 30 mA cm^{-2} , $80 \mu\text{l min}^{-1}$, MeCN/ H_2SO_4 (2 M)

Table 3.1: Influence of acetic anhydride content

The results from initial reactions (Table 3.1) were consistent with that reported, and a lower yield was obtained with a lower percentage of acetic anhydride, and a good yield was obtained when 25% acetic anhydride was present in the reaction system. The formation of 4-iodobenzyl acetate (Scheme 3.14) was observed when using 10% acetic anhydride at current densities higher than 30 mA cm^{-2} . Next the effect of current density on product yield was investigated using 25% acetic anhydride.

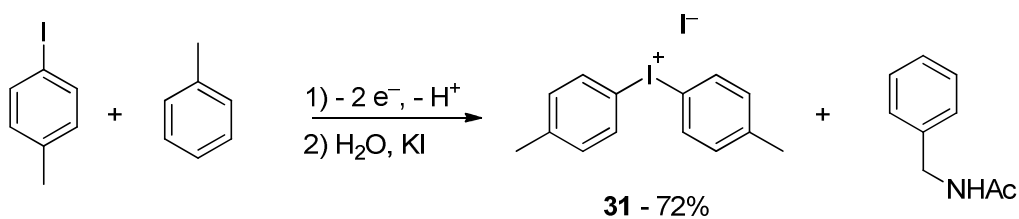

Scheme 3.15: The formation of **31** and *N*-benzyl acetamide side product with 25% volume acetic anhydride

Entry	Current Density (mA cm ⁻²)	Yield 31 (%)
1	30	72
2	35	49
3	40	47
4	45	50

0.1 M 4-iodotoluene, 0.3 M toluene, 80 $\mu\text{l min}^{-1}$, 25% volume acetic anhydride,
H₂SO₄ (2 M) in MeCN

Table 3.2: Influence of current density on product yield

As can be seen from Table 3.2, increasing current decreased the yield of the product due to the formation of side products. After precipitation of the product, extraction of the remaining aqueous solution with CHCl₃ led to *N*-benzyl acetamide side product being observed (Scheme 3.15). *N*-benzyl acetamide is formed from toluene being oxidised at the anode and undergoing a Ritter type reaction with the solvent acetonitrile (Scheme 3.16). This observation is not seen in a batch environment and is a disadvantage of the reaction being carried out in a microflow environment. Complete conversion of starting material to product is unlikely if the arene substrate is reacting with the electrode, causing a competing reaction for the iodoarene. As the arene is also in excess, it would make the oxidation of 4-iodotoluene less likely to occur. Therefore, a current density of 30 mA cm⁻² was chosen for the standard reaction conditions.

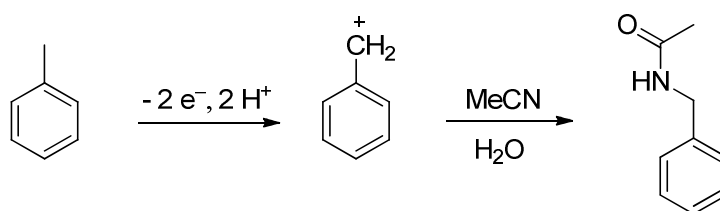

Scheme 3.16: Anodic oxidation of toluene forming the acetamide side product

With these reaction conditions (Scheme 3.17) a library of compounds was made of both symmetrical and unsymmetrical diaryliodonium salts (Table 3.3). As can be seen most of the yields obtained were good to reasonable with the exception of entries 6 and 10 when the aryl compound used was isopropylbenzene, suggesting that it is oxidised before the aryl iodide used in the reaction, with the exception of 4-iodotoluene under the reaction conditions on platinum electrodes.

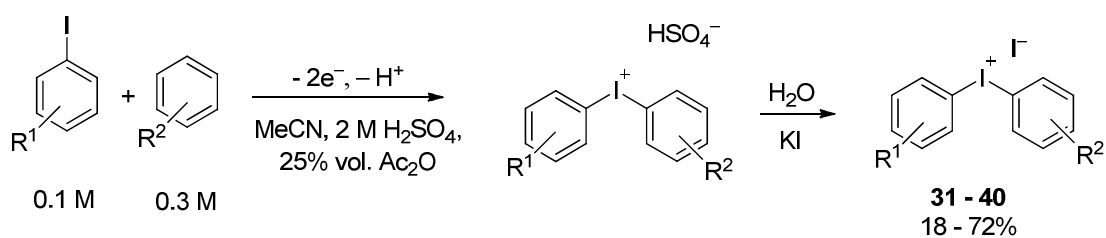

Scheme 3.17: Reaction conditions for the synthesis of diaryliodonium salts

Entry	R ¹	R ²	Compound	Yield (%)
1	4-Me	Me	31	72
2	4-Me	Et	32	51
3	4-Me	<i>i</i> -Pr	33	60
4	H	Me	34	44
5	H	Et	35	39
6	H	<i>i</i> -Pr	36	19
7	H	<i>t</i> -Bu	37	64
8	3-Me	Me	38	36
9	3-Me	Et	39	25
10	3-Me	<i>i</i> -Pr	40	18

Table 3.3: Yields of iodonium salts achieved in the flow

Reactions were also attempted with aryl compounds bearing substituents other than alkyl such as anisole and *p*-methoxy toluene, but as with the batch system reported, no product was observed. Indicating that the aryl substrate was being oxidised rather than the iodoarene to be able to form the coupling product.

A sequential reaction of the iodonium salt in flow was also attempted, for the arylation of 1,3-dicarbonyl compounds described by Ochiai *et al.*²⁴ (Scheme 3.18). The first issues encountered were regarding the enolate formation. This led to precipitation when the *t*-BuOK base was added to the diketone in THF. Co-solvents such as *t*-BuOH, dimethoxy ethanol or the addition of crown ethers to the reaction solution made no difference. Finally, when using a liquid base such as DBU (1,8-diazobicycloundec-7-ene) or triethylamine the enolate was able to remain in solution.

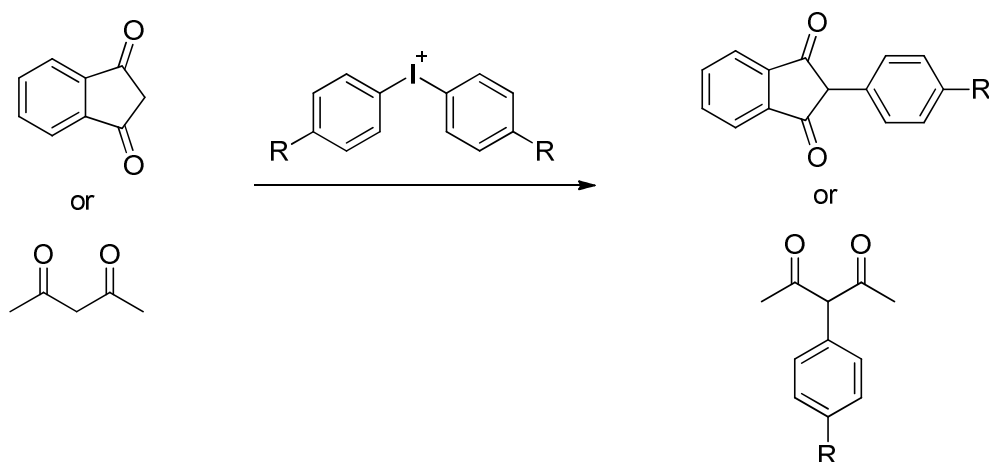

Scheme 3.18: Proposed sequential arylation of 1,3-dicarbonyl compounds²⁴

The soluble enolate was placed in a syringe and combined with the flow of diaryliodonium salt directly after leaving the electrochemical microreactor. The high concentration of sulphuric acid in the reaction mixture was reduced to a stoichiometric amount so the sequential reaction may occur. However there was no salt formation when reactions were run prior to addition of the diketone. The acid was increased slightly but unless it was in a large excess no salt precipitation was observed after the work-up procedure.

Reactions to form the salt in a different solvent system were then tried, as previously reported by Miller *et al.*²¹ in acetonitrile only. Reactions of this type led to a clogging of the reactor channel when current was applied. Attempts to prevent solid formation in the channel included the addition of water to the reaction mixture, however this had no effect and the reactor was unable complete the synthesis. This meant that it was not possible to create a set of reaction conditions where a sequential reaction of the preformed iodonium salt could be used in an arylation reaction without prior work-up and isolation of the product.

3.3 Conclusions

The synthesis of diaryliodonium salts in an electrochemical microreactor has been successfully achieved and has been published in the Beilstein Journal of Organic chemistry along with a video. The scope of the substrates is limited to those bearing alkyl substituents on the aromatic ring, whether on the aryl iodide or the arene. The close proximity of the electrodes seems to be a disadvantage in this case as it was

found that the aryl compound was being oxidised at the anode, and reacting with the solvent molecules in a Ritter type reaction to give the *N*-benzyl acetamide side product. This would cause a competing reaction at the anode for the aryl iodide and lower the yields obtained. The process, could however be run for unlimited time scales if necessary to produce large amounts of the desired compounds.

<http://www.beilstein.tv/typost/miniature-electrochemistry-in-flow/>

3.4 Experimental

General: Melting points were obtained in open capillary tubes and are uncorrected. ^1H NMR and ^{13}C NMR spectra were recorded on an AV-400 Bruker spectrometer, in the solvents indicated at 400 and 100 MHz, respectively, unless otherwise stated. Mass spectra (m/z) and HRMS were recorded under the conditions of electron impact (EI). Galvanostatic reactions were performed with a HEKA 510 galvanostat/potentiostat. No polishing of electrodes was needed, only cleaning with acetone was necessary. Acetonitrile was dried over 4 Å molecular sieves and all other chemicals were used as purchased without further purification.

General experimental procedure for the synthesis of iodonium salts 31 - 40

A 0.1 M solution of an aryl iodide and 0.3 M aryl compound was prepared in 2 M H_2SO_4 in acetonitrile with 25% volume acetic anhydride (typically 10 ml). The solution was placed in a syringe and introduced into the electrochemical device (reactor volume 22 μl) via a syringe pump (flow rate 80 $\mu\text{l min}^{-1}$ / residence time: 16.5 sec) with an applied current of 30 mA cm^{-2} . The reaction was allowed to reach equilibrium and the product solution was collected at the outlet. The solvent was removed *in vacuo*, water was added (3 ml) and the iodonium iodide salt was precipitated by addition of KI (166 mg, 1 mmol) to give the diaryliodonium salts **31 - 40**.

Di-*p*-tolyliodonium iodide (31)²⁵ - (9.3 ml collected in 116 min to give 291 mg, 72%)

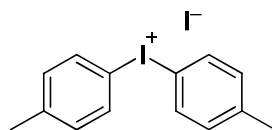

Yellow solid, m.p.: 162-164 °C; ¹H NMR (400 MHz, CDCl₃): δ = 2.27 (s, 6H, 2 x CH₃), 7.08 (d, *J* = 8.3 Hz, 4H, 2 x 2 CH), 7.74 (d, *J* = 8.3 Hz, 4H, 2 x 2 CH) ppm; HRMS (EI): calc. for C₁₄H₁₄I⁺: 309.0135, found: 309.0130.

(4-Ethylphenyl)(*p*-tolyl)iodonium iodide (32)²⁵ - (9.5 ml collected in 118 min to give 218 mg, 51%)

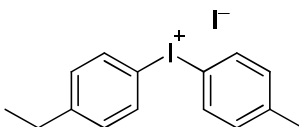

Orange/brown solid, m.p.: 156-158 °C; ¹H NMR (400 MHz, CDCl₃): δ = 1.13 (t, *J* = 7.6 Hz, 3H, CH₃), 2.27 (s, 3H, CH₃), 2.56 (q, *J* = 7.6 Hz, 2H, CH₂), 7.06 – 7.11 (m, 4H, 4 x CH), 7.74 – 7.79 (m, 4H, 4 x CH) ppm; HRMS (EI): calc. for C₁₅H₁₆I⁺: 323.0291, found: 323.0297.

(4-Isopropylphenyl)(*p*-tolyl)iodonium iodide (33)²⁵ - (9.5 ml collected in 118 min to give 264 mg, 60%)

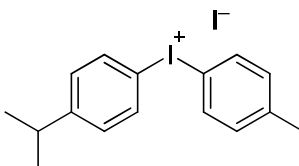

Yellow/brown solid, m.p.: 154-157 °C; ¹H NMR (400 MHz, CDCl₃): δ = 1.14 (d, *J* = 6.9 Hz, 6H, 2 x CH₃), 2.28 (s, 3H, CH₃), 2.81 (sept, *J* = 6.9 Hz, 1H, CH), 7.08 – 7.13 (m, 4H, 4 x CH), 7.75 – 7.78 (m, 4H, 4 x CH) ppm; HRMS (EI): calc. for C₁₆H₁₈I⁺: 337.0448, found: 337.0440.

Phenyl(*p*-tolyl)iodonium iodide (34)²⁵ - (9.6 ml collected in 120 min to give 178 mg, 44%)

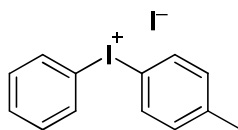

Orange/brown solid, m.p.: 135-139 °C; ¹H NMR (400 MHz, CDCl₃): δ = 2.27 (s, 3H, CH₃), 7.12 (d, *J* = 8.3 Hz, 2H, 2 x CH), 7.27 - 7.30 (m, 2H, 2 x CH), 7.48 (m, 1H, CH), 7.77 (d, *J* = 8.3 Hz, 2H, 2 x CH), 7.88 (d, *J* = 8.3 Hz, 2H, 2 x CH) ppm; HRMS (EI): calc. for C₁₃H₁₂I⁺: 294.9978, found: 294.9973.

(4-Ethylphenyl)(phenyl)iodonium iodide (35) - (9.5 ml collected in 118 min to give 161 mg, 39%)

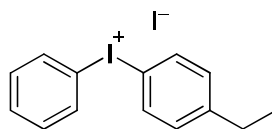

Yellow solid, m.p.: 159-161 °C; ¹H NMR (400 MHz, CDCl₃): δ = 1.14 (t, *J* = 7.6 Hz, 3H, CH₃), 2.57 (q, *J* = 7.6 Hz, 2H, CH₂), 7.12 (d, *J* = 8.4 Hz, 2H), 7.29 (t, *J* = 7.7 Hz, 2H), 7.44 (t, *J* = 7.4 Hz, 1H), 7.79 (d, *J* = 8.4 Hz, 2H), 7.88 (d, *J* = 7.5 Hz, 2H) ppm; ¹³C NMR (100 MHz, CDCl₃) δ = 14.9 (CH₃), 28.6 (CH₂), 117.5 (C_{Ar}), 121.1 (C_{Ar}), 131.1 (C_{Ar}), 131.2 (2x C_{Ar}), 131.5 (2 x C_{Ar}), 134.5 (2 x C_{Ar}), 134.8 (2 x C_{Ar}), 148.1 (C_{Ar}) ppm; HRMS (EI): calc. for C₁₄H₁₄I⁺: 309.0140, found: 309.0130.

(4-Isopropylphenyl)(phenyl)iodonium iodide (36) - (9.3 ml collected in 116 min to give 80 mg, 19%)

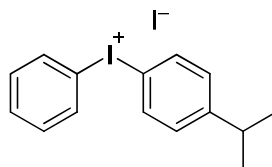

Yellow/brown solid, m.p.: 146-148 °C; ¹H NMR (400 MHz, CDCl₃): δ = 1.15 (d, *J* = 6.9 Hz, 6H, 2 x CH₃), 2.82 (sept, *J* = 6.9 Hz, 1H, CH), 7.14 (d, *J* = 8.4 Hz, 2H, 2 x CH), 7.30 (t, *J* = 7.8 Hz, 1H, CH), 7.44 (t, *J* = 4.4 Hz, 1H, CH), 7.79 (d, *J* = 8.4 Hz, 2H, 2 x CH), 7.89 (d, *J* = 7.6 Hz, 2H, 2 x 2 CH) ppm; ¹³C NMR (125 MHz, CDCl₃) δ

= 23.6 (2 x CH₃), 34.0 (CH), 117.4 (C_{Ar}), 121.2 (C_{Ar}), 129.9 (2 x C_{Ar}), 131.1 (C_{Ar}), 131.5 (2 x C_{Ar}), 134.6 (2 x C_{Ar}), 134.7 (2 x C_{Ar}), 152.7 (C_{Ar}) ppm; HRMS (EI): calc. for C₁₅H₁₆I⁺: 323.0291, found: 323.0298.

(4-(*Tert*-butyl)phenyl)(phenyl)iodonium iodide (37) - (9.6 ml collected in 120 min to give 285 mg, 64%)

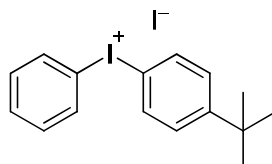

Brown solid, m.p.: 162-164 °C; ¹H NMR (400 MHz, CDCl₃): δ = 1.23 (s, 9H, 3 x CH₃), 7.35 – 7.37 (m, 4H, 4 x CH), 7.48 (t, *J* = 7.4 Hz, 1H, CH), 7.86 – 7.88 (m, 2H, 2 x CH), 7.96 – 7.99 (m, 2H, 2 x CH) ppm; ¹³C NMR (100 MHz, CDCl₃) δ = 30.0 (3 x CH₃), 34.1 (CH), 116.5 (C_{Ar}), 120.4 (C_{Ar}), 127.8 (2 x C_{Ar}), 130.0 (C_{Ar}), 130.4 (2 x C_{Ar}), 133.4 (2 x C_{Ar}), 133.7 (2 x C_{Ar}), 153.7 (C_{Ar}) ppm; HRMS (EI): calc. for C₁₆H₁₈I⁺: 337.0448, found: 337.0451.

***m*-Tolyl(*p*-tolyl)iodonium iodide (38)²⁵** - (9.4 ml collected in 117 min to give 147 mg, 36%)

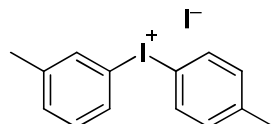

Brown solid, m.p.: 85-89 °C; ¹H NMR (400 MHz, CDCl₃): δ = 2.27 (s, 6H, 2 x CH₃), 7.09 (d, *J* = 8.1 Hz, 2H, 2 x CH), 7.19 (m, 2H, 2 x CH), 7.65 (d, *J* = 7.9 Hz, 1H, CH), 7.72 (s, 1H, CH), 7.79 (d, *J* = 8.8 Hz, 2H, 2 x CH) ppm; HRMS (EI): calc. for C₁₄H₁₄I⁺: 309.0135, found: 309.0141.

(4-Ethylphenyl)(*m*-tolyl)iodonium iodide (39) - (9.6 ml collected in 120 min to give 108 mg, 25%)

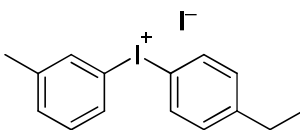

Yellow solid, m.p.: 124-127 °C; ^1H NMR (400 MHz, CDCl_3): δ = 1.14 (t, J = 7.6 Hz, 3H, CH_3), 2.28 (s, 3H, CH_3), 2.57 (q, J = 7.6 Hz, 2H, CH_2), 7.12 (d, J = 8.5 Hz, 2H, 2 x CH), 7.15 – 7.24 (m, 2H, 2 x CH), 7.67 (d, J = 7.9 Hz, 1H, CH), 7.74 (s, 1H, CH), 7.80 (d, J = 8.5 Hz, 2H, 2 x CH) ppm; ^{13}C NMR (100 MHz, CDCl_3) δ = 13.9 (CH_3), 20.4 (CH_3), 27.6 (CH_2), 116.1 (C_{Ar}), 119.7 (C_{Ar}), 130.2 (C_{Ar}), 130.3 (2 x C_{Ar}), 130.6 (C_{Ar}), 131.2 (C_{Ar}), 133.6 (2 x C_{Ar}), 133.9 (C_{Ar}), 141.1 (C_{Ar}), 147.1 (C_{Ar}) ppm; HRMS (EI): calc. for $\text{C}_{15}\text{H}_{16}\text{I}^+$: 323.0291, found: 323.0298.

4-Isopropylphenyl)(*m*-tolyl)iodonium iodide (40) - (9.6 ml collected in 120 min to give 108 mg, 25%)

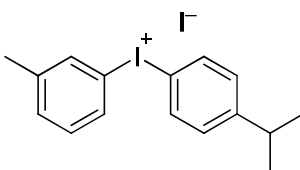

Yellow solid, m.p.: 152-155 °C; ^1H NMR (400 MHz, CDCl_3): δ = 1.14 (d, J = 6.9 Hz, 6H, 2 x CH_3), 2.27 (s, 3H, CH_3), 2.81 (sept, J = 6.9, 1H, CH), 7.13 (d, J = 8.4 Hz, 2H, 2 x CH), 7.20 (m, 2H, 2 x CH), 7.68 (d, J = 8.0 Hz, 1H, CH), 7.75 (s, 1H, CH), 7.80 (d, J = 8.4 Hz, 2H, 2 x CH) ppm; ^{13}C NMR (100 MHz, CDCl_3) δ = 20.4 (CH_3), 22.6 (2 x CH_3), 32.9 (CH), 116.0 (C_{Ar}), 119.6 (C_{Ar}), 128.8 (2 x (C_{Ar}), 130.1 (C_{Ar}), 130.7 (C_{Ar}), 131.0 (C_{Ar}), 133.6 (2 x (C_{Ar}), 134.0 (C_{Ar}), 140.9 (C_{Ar}), 151.4 (C_{Ar}) ppm; HRMS (EI): calc. for $\text{C}_{16}\text{H}_{18}\text{I}^+$: 337.0448, found: 337.0444.

3.5 References

1. B. Olofsson and E. Merritt, *Angew. Chemie, Int. Ed. English*, **2009**, *48*, 9052.
2. V. V Zhdankin, M. S. Yusubov, and A. V Maskaev, *Arkivoc*, **2011**, 370.
3. P. J. Stang, *J. Org. Chem.*, **2003**, *68*, 2997.

4. P. J. Stang and V. V. Zhdankin, *Chem. Rev.*, **1996**, *96*, 1123.
5. T. Okuyama, T. Takino, T. Sueda, and M. Ochiai, *J. Am. Chem. Soc.*, **1995**, *117*, 3360.
6. C. Hartmann and V. Meyer, *Berichte der Dtsch. Chem. Gesellschaft*, **1984**, *27*, 426.
7. M. Beringer, M. Drexler, E. Gindler, and C. Lumpkin, *J. Am. Chem. Soc.*, **1953**, 2705.
8. F. Marshall, M. Beringer, R. Falk, M. Karniol, I. Lillien, G. Masullo, M. Mausner, and E. Sommer, *J. Am. Chem. Soc.*, **1959**, *81*, 342.
9. G. Koser and R. Wettach, *J. Org. Chem.*, **1980**, *45*, 1543.
10. T. Kitamura and M. D. Hossain, *Tetrahedron*, **2006**, *62*, 6955.
11. B. Olofsson and M. Bielawski, *Chem. Commun.*, **2007**, *24*, 2521.
12. M. Ochiai, Y. Kitagawa, N. Takayama, Y. Takaoka, and M. Shiro, *J. Am. Chem. Soc.*, **1999**, *121*, 9233.
13. V. K. Aggarwal and B. Olofsson, *Angew. Chemie, Int. Ed. English*, **2005**, *44*, 5516.
14. M. Zhu, Y. Song, and Y. Cao, *Synthesis*, **2007**, *6*, 853.
15. N. R. Deprez, D. Kalyani, A. Krause, and M. S. Sanford, *J. Am. Chem. Soc.*, **2006**, *128*, 4972.
16. T. Kitamura, M. Todaka, and Y. Fujiwara, *Org. Synth.*, **2002**, *78*, 104.
17. T. Kitamura, M. Yamane, K. Inoue, M. Todaka, N. Fukatsu, Z. Meng, and Y. Fujiwara, *J. Am. Chem. Soc.*, **1999**, *121*, 11674.
18. T. Kitamura, Z. Meng, and Y. Fujiwara, *Tetrahedron Lett.*, **2000**, *41*, 6611.
19. T. Kitamura, Y. Aoki, S. Isshiki, K. Wasai, and Y. Fujiwara, *Tetrahedron Lett.*, **2006**, *47*, 1709.
20. J. Xue and X. Huang, *Synth. Commun.*, **2007**, *37*, 2179.
21. L. L. Miller and A. K. Hoffmann, *J. Am. Chem. Soc.*, **1965**, *89*, 593.
22. H. Hoffelner, H. Lorch, and H. Wendt, *J. Electroanal. Chem.*, **1975**, *66*, 183.
23. D. Pletcher and M. J. Peacock, *Tetrahedron Lett.*, **2000**, *41*, 8995.

24. M. Ochiai, T. Shu, T. Nagaoka, and Y. Kitagawa, *J. Org. Chem.*, **1997**, *62*, 2130.
25. D. Pletcher and M. J. Peacock, *J. Electrochem. Soc.*, **2001**, *148*, D37.

Chapter 4

The synthesis of Carbamates via a Hofmann
Rearrangement and the Use of
Electrochemical Mediators in Flow

4.1. Introduction

Nitrogen-containing compounds are important in a large part of organic chemistry. Compounds such as amines, amides, azo compounds and many heterocyclic systems all contain nitrogen atoms. Isocyanates are also such compounds and in 2001 more than 5 megatons of isocyanates were manufactured world-wide for processes such as the production of paints to create weather resistant coatings, and for building materials such as flexible foams.¹ Isocyanates are useful reagents for the synthesis of amines, carbamates and *N,N*-disubstituted ureas. The most common method for producing isocyanates involves the reaction of phosgene **41** with an amine. Initially **41** reacts with the amine to form an intermediate which will break down to give a carbamoyl chloride. The carbamoyl chloride can then eliminate HCl to give the isocyanate **42**, or the urea if the isocyanate molecules react with the amine (Scheme 4.1). Nowadays safer and less toxic alternatives to phosgene are used, such as diphosgene (trichloromethyl chloroformate) or triphosgene (bis(trichloromethyl) carbonate).^{2,3}

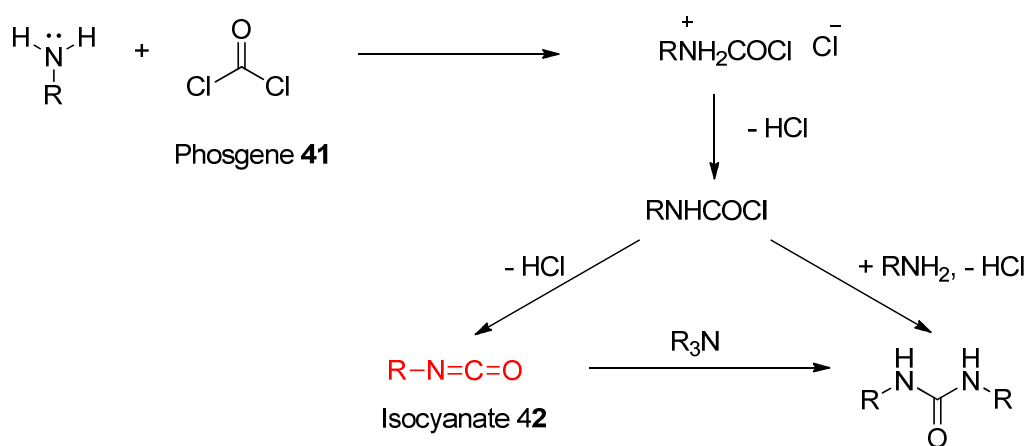

Scheme 4.1: Isocyanate synthesis from phosgene

Carbamates are useful functional groups for production of many pharmaceuticals and agrochemicals, specifically pesticides. Some examples of where the carbamate group has been found to be of great importance are shown below, with the carbamate moieties in red (Figure 4.1).⁴ Linezolid (**43**), is reported as the first member of a completely new class of antibacterial agents, the first to have been developed since nalidixic acid was approved in 1963, and has been used to treat more than 3 million patients.⁵ Physostigmine (**44**) is used for the medical treatment of glaucoma and can

be used to treat organophosphate poisoning, but it has also found use in the treatment of Alzheimer's disease when given to patients in larger doses and for prolonged periods.⁶ The last example, carbaryl (**45**), is used as a pesticide for food crops and is also the active ingredient in Carylderm[®] head lice shampoo. It was the first *N*-methylcarbamate to be successfully introduced to the market in 1958 and is still one of the most widely used pesticides in the United States for both commercial and home use.⁷ There are also many carbamate containing potential anticancer, antimalarial, antidiabetic and antiviral drugs, with many more studies being done on the potential uses in other areas of medicine.⁴

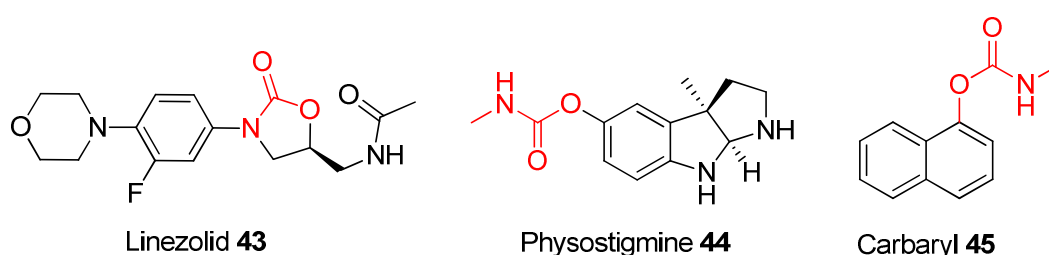
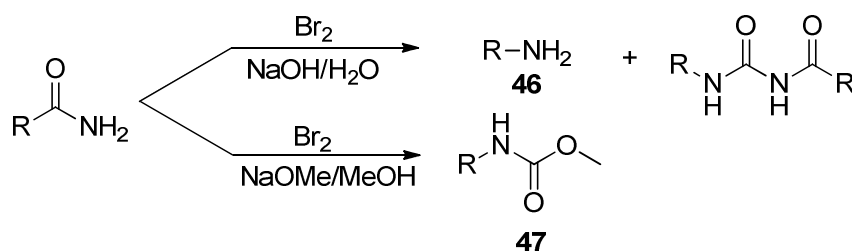

Figure 4.1: Carbamate functionalities in Pharmaceuticals and pesticides

The Hofmann rearrangement is one of the oldest transformations in organic synthesis. The traditional rearrangement is used for the conversion of a primary amide to a primary amine **46** with the loss of one carbon atom from the chain using aqueous NaOH and Br₂, but it can be modified to give carbamates **47** when the solvent system is changed to methanol in the presence of sodium methoxide (Scheme 4.2).



Scheme 4.2: Products of Hofmann rearrangements

The mechanism (Scheme 4.3)⁸ starts with the reaction of the amide with hypobromite in aqueous alkaline solution to give the *N*-bromoamide **48**. This intermediate shows NH acidity due to the two electron withdrawing substituents, and

can again be deprotonated to give the anionic bromoamide species. This will then eliminate Br^- and rearrange to give the isocyanate **49**. Water can act as a nucleophile and attack the isocyanate to give the carbaminic acid, this then decomposes to give the amine as the product.

The important intermediate in the reaction is the isocyanate **49**. When methanol is used as the solvent instead of water, the carbamate is produced. Isocyanates are very reactive compounds, specifically towards alcohols and water and this explains the products and side products found from both the Hofmann and the modified Hofmann rearrangement. Some common reaction products formed from isocyanate reactions are shown in Scheme 4.4.⁹

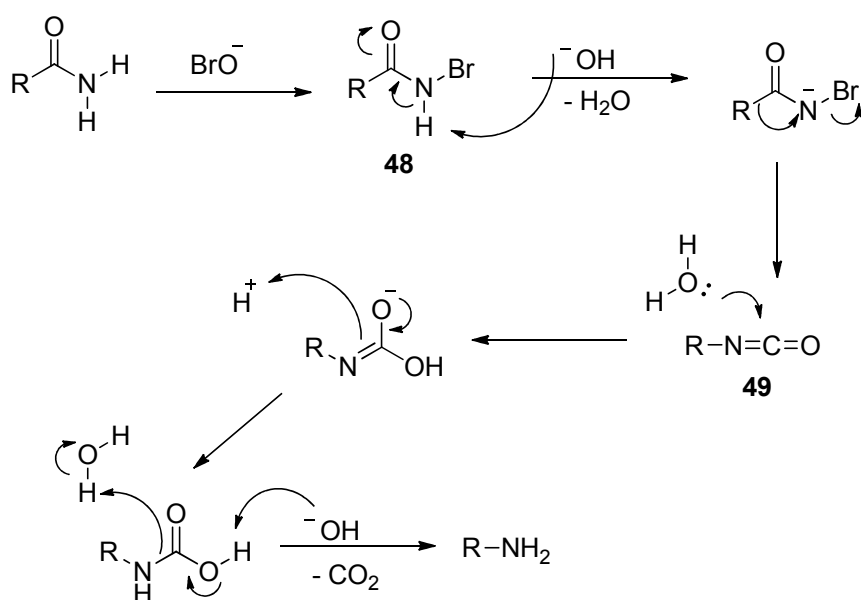

Scheme 4.3: Mechanism of the Hofmann rearrangement

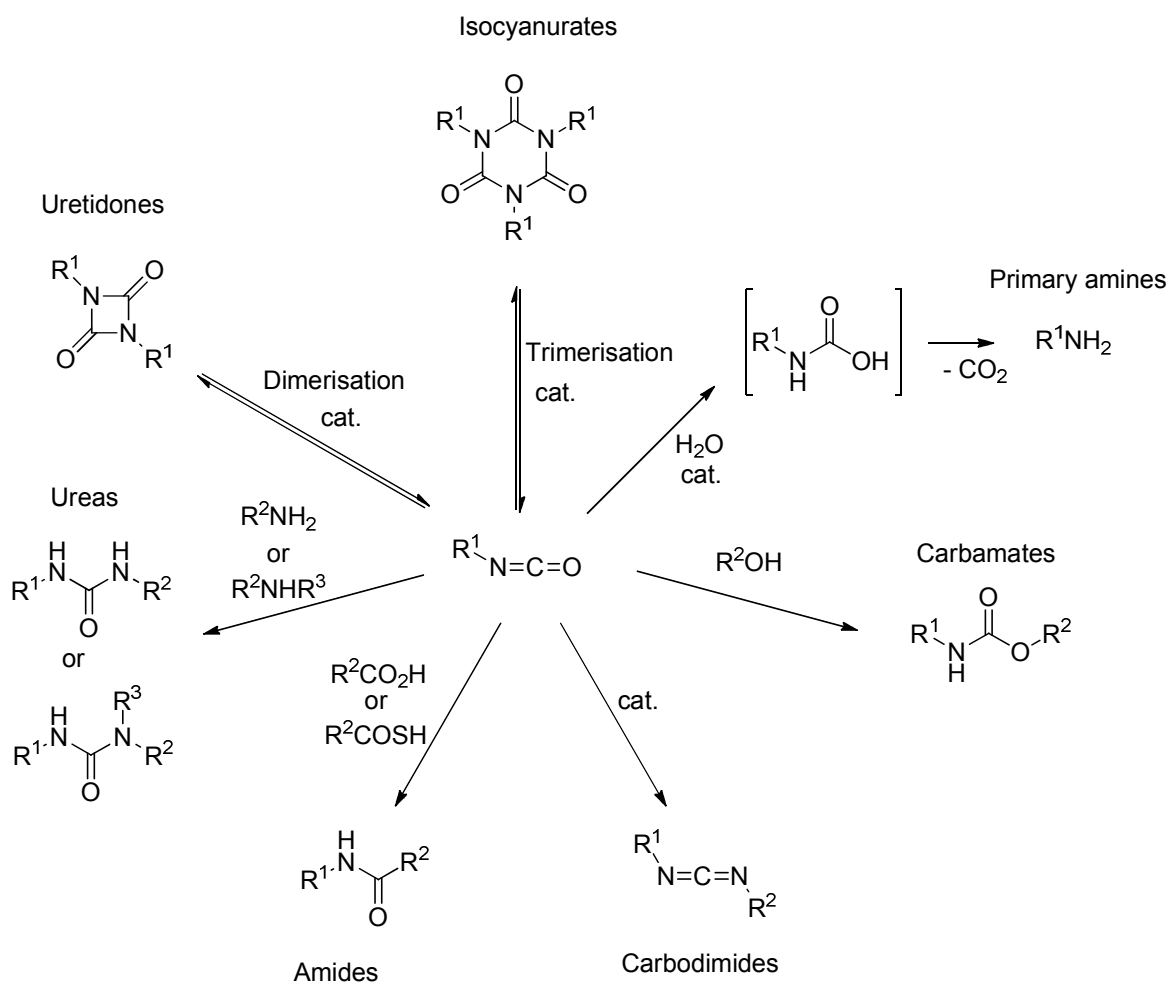

Scheme 4.4: Reactions of isocyanates

There are two other rearrangement reactions in organic chemistry that are similar to the Hofmann rearrangement, the Curtius and Lossen rearrangements (Scheme 4.5) both involving isocyanate intermediates. The Curtius rearrangement uses an acyl azide as the starting material which then thermally decomposes to yield the isocyanate with evolution of nitrogen. When the reaction is carried out in an inert solvent in the absence of water, the isocyanate can be isolated, but if in an aqueous solution, as with the Hofmann rearrangement, the amine is formed. The Lossen rearrangement is the conversion of hydroxamic acid derivatives into isocyanates, *via* deprotonation of the starting material followed by a rearrangement. This reaction is of less use in organic synthesis compared to the other examples because of the poor availability of the hydroxamic acid derivatives, some even being unreactive.⁸

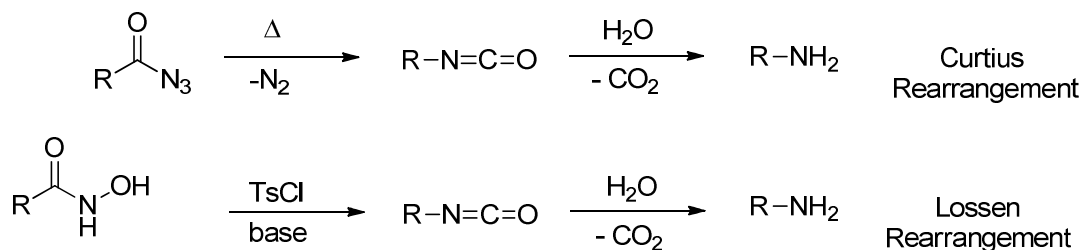

Scheme 4.5: The Curtius and Lossen rearrangements

Modifications of the Hofmann rearrangement have led to methyl carbamates being formed in good to excellent yields, with milder conditions and many different oxidising agents such as lead tetraacetate, iodine (III) species and *N*-bromosuccinimide (NBS) – Hg(OAc)₂; milder bases have also been tested and so the reaction of many more substrates can now be carried out with good results.

In 1997 Keillor *et al.*¹⁰ published a modification of the Hofmann rearrangement, and they found that with literature procedures, they could not convert *p*-methoxybenzamide into anisidine because the powerful oxidising agents being used rapidly decomposed the product. A procedure was developed with milder conditions to prevent the further oxidation of the desired product. By using NBS and NaOMe in methanol, instead of NBS and lead acetate, an excellent yield was obtained under reflux with a complete reaction after only 10 minutes (Scheme 4.6 a).

The same authors found that these conditions were unsuitable for the conversion of *p*-nitrobenzamide or *p*-(dimethylamino)benzamide due to the presence of the strong base, NaOMe. They went on to modify their previous procedure by using 1,8-diazobicyclo[5.4.0]undec-7-ene (DBU).¹¹ This method, although requiring a longer reaction time under reflux, gave good conversions of a wide variety of alky and aryl carbamates (Scheme 4.6 b).

In 1993 Moriarty *et al.*¹² published the preparation of methyl carbamates using hypervalent iodine reagents. Previously reported methods using these reagents had been less useful because the hypervalent iodine reagents needed to be freshly prepared due to their instability or the failure of others to reproduce reported conditions. Their aim was to devise a modified Hofmann rearrangement without the use of bromine, heavy metals and reflux conditions. By using PhI(OAc)₂ ((diacetoxyiodo)benzene, DIAB), they were able to successfully convert a selection

of 14 different aryl and alkyl amides to their corresponding carbamates using a methanolic solution of KOH at 5-10 °C with the reaction completed in an hour. They found that by using basic conditions arylcarboxamides could be converted in good yields which was not possible when carried out under acidic conditions (Scheme 4.6 c).

A modification of the Hofmann rearrangement has also been reported by Gogoi *et al.*¹³ using a solid-supported base. Solid-supported reactions have been shown to be very useful at enhancing reactivity and selectivity, as well as allowing milder conditions and the avoidance of the traditional aqueous work-up. The solid-supported base being used is a catalytic amount of KF/Al₂O₃, which is known to be a strong base. They also use NaOCl as the oxidant which is an inexpensive and safer alternative to many of the oxidising reagents previously used. This system was shown to give good to excellent yields of carbamates, aliphatic and aromatic carbamates including examples with sulphur or nitrogen containing heterocycles (Scheme 4.6 d).

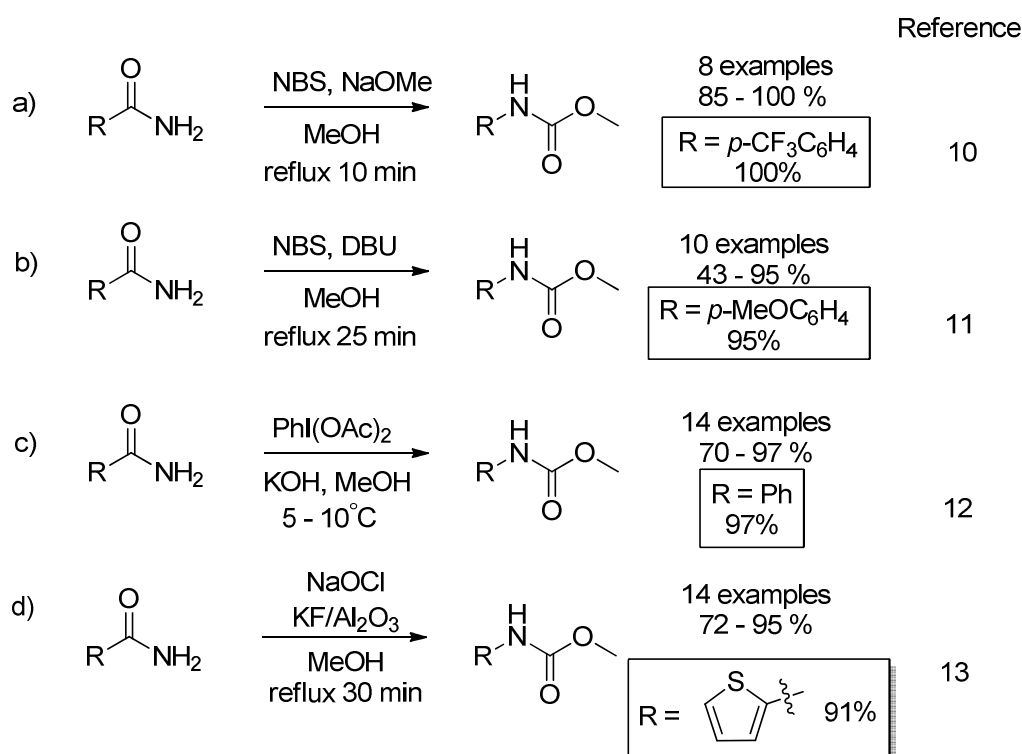

Scheme 4.6: Conditions of modified Hofmann rearrangements

More recently, Ley *et al.*¹⁴ reported the modified Hofmann rearrangement using a commercial microreactor developed for organic synthesis. The device comprised of a base module and up to three computer-controlled syringe pumps. A general set of conditions was established. Two flow streams were used for the synthesis: the first including the substrate with DBU as the base in either methanol or ethanol, the second was the bromine source, NBS also in methanol or ethanol: the streams were then combined in a T-mixer and were introduced into a reactor coil with a residence time of 1 minute (Scheme 4.7). The conditions were the same as the previously reported modification by Keillor *et al.*¹¹ however the microreactor system, together with superheated methanol in the coil reduced the reaction time from 25 minutes to 1 minute demonstrating the benefits of flow chemistry. Substrates tested included aryl amides with both electron donating and withdrawing substituents on the aromatic ring with good yields. All reactions were carried out between 50 – 100 μg scale, with three substrates being scaled up to the gram scale with yields of up to 88%.

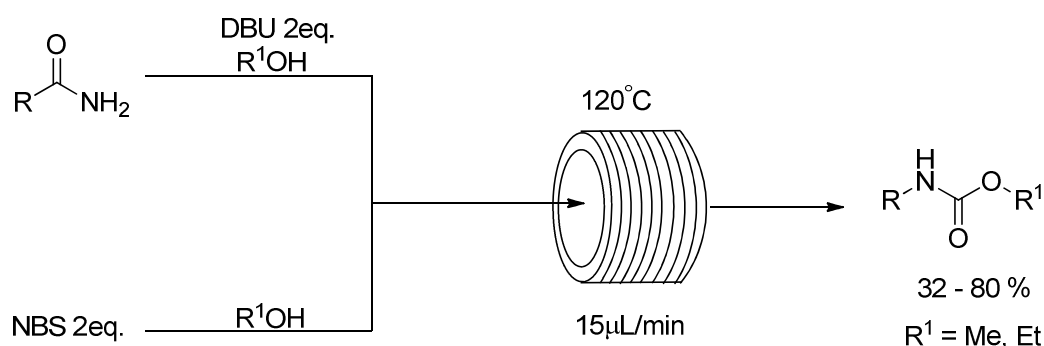

Scheme 4.7: A microreactor system for the Hofmann rearrangement

4.2 Electrochemically induced Hofmann rearrangement

In 1982 Shono *et al.*¹⁵ reported the Hofmann rearrangement induced by an electrochemical method and this will be the main discussion of the chapter, converting this method into a suitable flow procedure for the synthesis of carbamates.

The method described by Shono *et al.*¹⁵ showed an electrochemical mediatory system (Section 1.10.2) where they converted primary amides to carbamates under mild conditions. The reaction system comprised of KBr in methanol, in which KBr was used in catalytic amounts. Under normal conditions, the reaction is very basic,

needing two equivalents of base for the rearrangement to occur. In the reaction vessel the bromide ion and the potassium cation both undergo simultaneous electrochemical reactions, at the anode, bromide ion to bromonium ion, and at the cathode, potassium cation to potassium (Scheme 4.8). The reaction system involves the reaction of the substrate with bromine and potassium methoxide formed *in situ*.

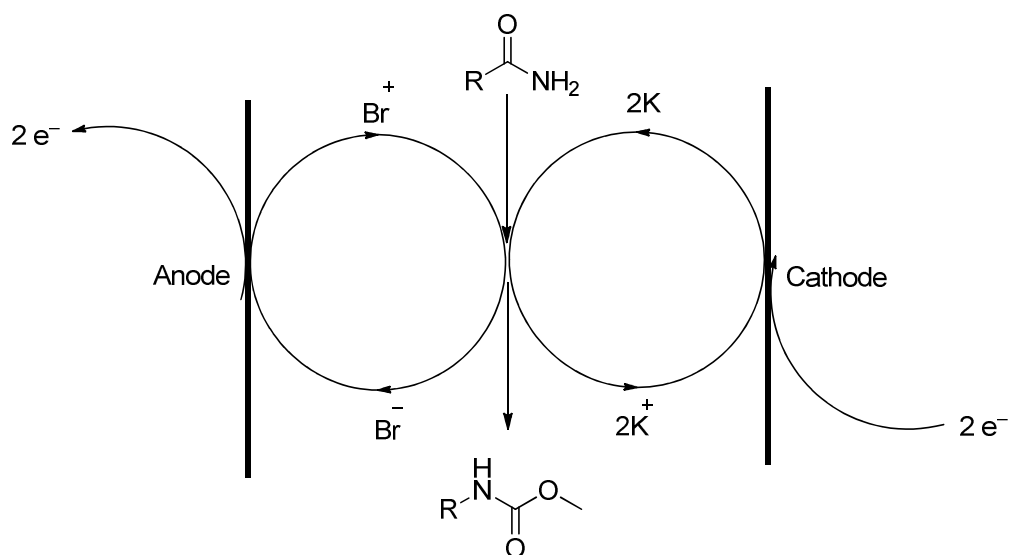

Scheme 4.8: Electrochemically induced Hofmann rearrangement

The authors demonstrated that the rearrangement took place giving good yields for a range of substrates using either 0.1 or 0.3 equivalents of KBr. The reaction was also shown to proceed when using potassium chloride, although a decrease in yield was observed. However, no reaction occurred when potassium iodide was used. This suggests that the larger size of the iodonium ion and its lower electron affinity is affecting the rearrangement as it is more easily oxidised than bromide and chloride (-0.54, -1.06, -1.36 V respectively)¹⁶

This method using methanol as the solvent was only useful for producing methyl carbamates, as with the other previous modifications to the Hofmann rearrangement. However Matsumura *et al.*^{17,18} continuing with the work presented above developed a method to produce not only methyl carbamates, but a variety of alkyl carbamates, being able to vary both the amide and alcohol functional groups. Such a general method for the Hofmann rearrangement had never been reported.

The main modification to the above system was the change in solvent from methanol, to acetonitrile containing an alcohol present from 1 to 10 equivalents. Reduction of the alcohol provided the electrogenerated base, while tetraethylammonium bromide was the choice of bromide source. When using hexanamide as the substrate, the authors reported a 98% yield of the corresponding methyl carbamate. High yields were also obtained for a number of primary alcohols. They also succeeded using isopropyl alcohol but when *t*-butyl alcohol was used there was no conversion to the product.

Hexanoamide was chosen as the substrate for a model reaction to compare with the chemical method, where only 30% of the desired carbamate was obtained with 40% of the *N*-alkyl-*N'*-acylurea side product, said to be from the intermediate **49** reacting with the isocyanate, highlighting the benefits of the electrochemical method versus the batch method.

The same authors then investigated the mechanism of the electrochemically induced method as shown in Scheme 4.9.¹⁸

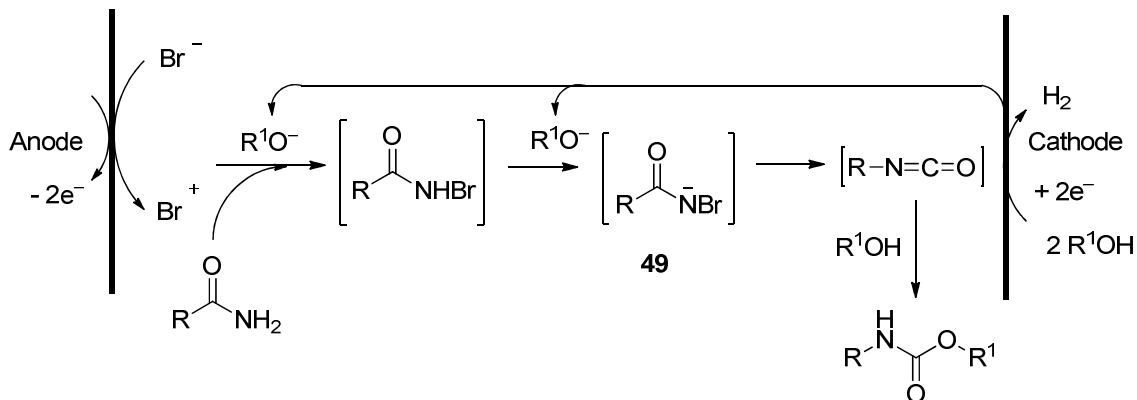

Scheme 4.9: Mechanism of the electrochemically induced Hofmann rearrangement¹⁸

The mechanism presented uses a paired electrochemical reaction as with the KBr system. The reaction is initiated after oxidation of bromide at the anode, and the reduction of alcohol at the cathode to form the base, leading to the first *N*-bromoamide intermediate. This then undergoes a second deprotonation to form the anionic intermediate **49** which allows for the rearrangement to occur and form the isocyanate. The alcohol present can then attack the isocyanate as a nucleophile giving the desired carbamates.

The authors show that the intermediates in both the electrochemically induced and in the typical Hofmann rearrangement are the same, however because of the highly basic nature of the chemical method, the anionic bromoamide species **49** is in a much higher concentration, and this intermediate reacts with the isocyanate to give the *N*-alkyl-*N'*-acylurea side products. To avoid large amounts of this side product, the chemical method can be heated to speed up the degradation of the anionic intermediate to the isocyanate. This is unnecessary in the electrochemical method because the reactions are run at ambient temperature, and at all times during the reaction the solution is neutral. The authors showed that a substrate possessing an epoxy group could be converted under the reaction conditions indicating that this method is applicable to a wider range of substrates.

4.3. Results and discussion

4.3.1 Electrochemically induced Hofmann rearrangement in flow

Work to design a general experimental procedure for the production of a variety of substituted carbamates in flow began from the system developed by Matsumura *et al.*¹⁸ The substrate chosen to begin with was cyclohexanoamide **50**. In a general procedure for reactions Matsumura *et al.* used a catalytic amount of the bromine source and five equivalents of alcohol were used.

Unlike in a batch system where the bromine source can be indefinitely regenerated for the full reaction time, in flow, the reaction time is much shorter due to the residence time in the flow reactor. Concerned that using a catalytic amount of bromine source in a flow system would lower the yields, initial reactions were carried out with one equivalent of tetraethylammonium bromide (TEAB).

Preliminary experiments were carried out at a concentration of 0.1 M with respect to the amide and reactions were monitored by TLC and NMR. The current reported by Matsumura *et al.*¹⁸ was 100 mA with a working electrode area double with respect to our device, so this was lowered to 50 mA cm⁻² for initial reactions, with 5 equivalents of alcohol. These conditions were a very inefficient reaction set-up as it could be seen from the NMR and TLC results that the amount of unreacted starting material was much higher than any other compounds visible. The reaction solution

was then changed to reduce the concentration of **50** to 0.05 M while keeping the current density at 50 mA cm^{-2} and other variables constant.

After more reactions varying flow rates, no real progress in fully converting **50** during the reaction was made, so it was necessary to proceed with a larger scale, typically a 10 ml reaction solution, so the products could be isolated. The reaction system was proven to be moderately successful with a substrate and salt concentration of 0.05 M, alcohol concentration of 0.25 M, with a current density of 50 mA cm^{-2} and residence time of 16.5 seconds (Scheme 4.10). Yields are shown in Table 4.1.

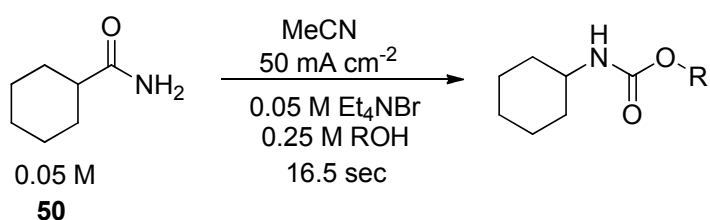

Scheme 4.10: Initial reaction conditions

Entry	Alcohol (ROH)	Product	Yield (%)
1	<i>n</i> -BuOH	51	31
2	<i>i</i> -PrOH	52	4
3	1,1,1-trifluoroethanol	53	26

Table 4.1: Yields obtained from initial reaction conditions

Although the reaction conditions had yielded the desired carbamates, the yields were lower than reported by Matsumura *et al.*¹⁸ (40 and 95% of **51** and **53**, respectively).

In order to improve yields, the alcohol stoichiometry was increased from 5 to 10 equivalents while all other parameters were kept identical to previous reactions (Scheme 4.11). Again the reactions were carried out on 10 ml scale to isolate products by column chromatography. The yields of products with an increased alcohol stoichiometry are presented in Table 4.2. Both entries 1 and 2 showed an increase in yield with an increased alcohol concentration (Table 4.2). In the case of trifluoroethanol (Entry 3, Table 4.2), the NMR spectra showed a large amount of side products with no major side product being isolated, unlike with the other alcohols used which were much cleaner reactions with regards to the side products

formed. Substrate **50** was then taken to create a set of examples of carbamates with a variety of alcohols to create a general procedure for the production of carbamates in flow (Scheme 4.11).

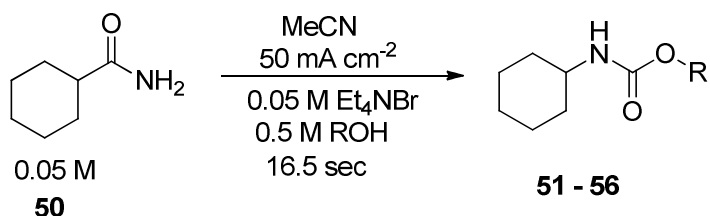

Scheme 4.11: Improved reaction conditions

Entry	Alcohol (ROH)	Product	Yield (%)
1	<i>n</i> -BuOH	51	68
2	<i>i</i> -PrOH	52	29
3	1,1,1-Trifluoroethanol	53	25
4	MeOH	54	11 - 14
5	Benzyl alcohol	55	50
6	EtOH	56	61
7	<i>t</i> -BuOH		/

Table 4.2: Yields of carbamates produced varying the alcohol

The general method was shown to be successful with a variety of alcohols, with comparable yields to those achieved in batch reactions in some cases. In the case using *n*-BuOH as the alcohol to synthesise **51**, a higher yield was achieved than in batch (31%), albeit with a higher concentration of alcohol, 10 equivalents compared to 5. In the case of *t*-BuOH, the same result as the batch reaction was obtained and no reaction occurred with the starting material being recovered, most likely due to the steric hindrance caused by the bulky substituent.

The most surprising result was the reaction with methanol (Entry 4, Table 4.2), this can be attributed to the methanol being oxidised at the anode, competing with the bromine source and inhibiting the initial reaction. A more likely reasoning can be made that the reduction potential of the supporting electrolyte, in this case tetraethylammonium bromide (TEAB), is lower than that of methanol, inhibiting the

methanol from reacting at the electrode. As a consequence there is no base being generated in the reaction system for the reaction to proceed.

The tetraalkylammonium salts are said to be reduced at more negative potentials with increasing size of the alkyl group.^{19,20} To investigate this, a second supporting electrolyte was used, tetrabutylammonium bromide (TBAB limiting reduction potential – 2.76 V vs SCE). Once again the general experimental procedure was used and this was successful in increasing the yield to 64% (Scheme 4.12). The improvement in yield showed that the TEAB was almost certainly having some effect on the electrogeneration of methoxide during the reaction.

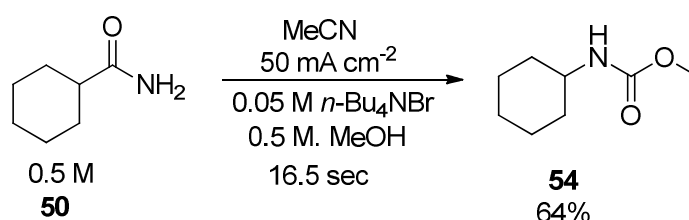

Scheme 4.12: Improved yield with change of electrolyte

From the increased yield obtained, some of the lower yielding substrates were once again subjected to the same general reaction conditions with TBAB hoping the same effect could be seen. This was true for isopropyl alcohol, an increase to 69% was observed, and ethanol from 61 to 70% (Entry 2, Table 4.3). The only reaction to not be affected by this change in electrolyte was trifluoroethanol which remained fairly constant under the three reaction conditions used due to side products being formed. Possible side products being formed would be the *N*-alkyl-*N'*-acylurea, formed from the reaction of the anionic intermediate **49**, with the isocyanate (Scheme 4.2), but no major side products could be identified after column chromatography.

Entry	Alcohol (ROH)	Product	Yield (%)
1	<i>i</i> -PrOH	52	69
2	EtOH	56	70
3	MeOH	54	64
4	1,1,1-Trifluoroethanol	53	25

MeCN, 80 μ l min⁻¹, 50 mA cm⁻², 0.05 M *n*-Bu₄NBr, 0.5 M ROH

Table 4.3: Effect of changing the supporting electrolyte

The reaction was then carried out under the general conditions with TBAB using two aromatic substrates to see if the reaction success could be applied to other systems (Scheme 4.13). The desired aromatic ethyl carbamates **57** and **58** were obtained but yields (29% and 22% respectively) were lower than that for substrate **50** under identical condition. TLC monitoring of the reactions showed the presence of many compounds visible in comparison to cyclohexanoamide **50**. Again no major side product could be isolated suggesting that the substrates themselves were also undergoing some reaction, possibly being oxidised by the electrode, ultimately lowering the yield of the desired compounds.

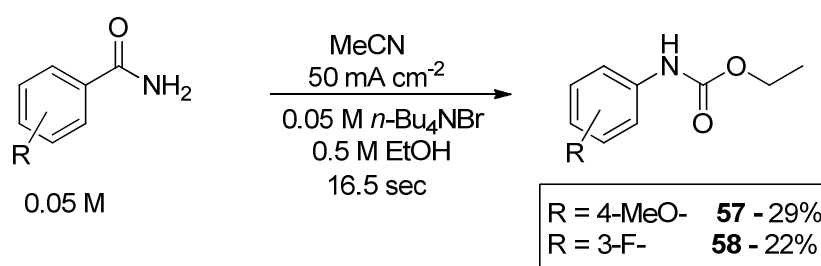

Scheme 4.13: Hofmann rearrangement with aromatic substrates

Now that a set of compounds using different alcohols and aromatic substrates had been undertaken, the reaction using cyclohexanoamide **50**, with ethanol was taken to optimise production of **56**. First the supporting electrolyte was varied; however now the halide ion of the supporting electrolyte was being investigated. Reactions were carried out with both tetrabutylammonium chloride and iodide, both causing a decrease in the obtained yields, 25 and 16% respectively (Table 4.4). This being the same result found in the batch reactions carried out by Matsumura *et al.*¹⁸ achieving yields of 24% for TEACl and 20% TEAI indicating that the chloronium and iodonium species are less efficient as oxidising agents to induce the Hofmann rearrangement.

Entry	Halide ion	Yield 56 (%)
1	Br ⁻	70
2	Cl ⁻	25
3	I ⁻	16

MeCN, 80 $\mu\text{l min}^{-1}$, 50 mA cm^{-2} , 0.5 M EtOH

Table: 4.4: Effects of halide ion being oxidised on product formation

Taking the reaction of cyclohexanoamide **50**, with ethanol as the reaction substrates, last attempts to increase the yield and determine the best conditions were undertaken. This involved reactions investigating the equivalents of electrolyte present, an increase in alcohol concentration, longer and shorter residence times, and a lower concentration of substrate **50** (Table 4.5).

Entry	Variable	Yield 56 (%)
1	0.05 M <i>n</i> -Bu ₄ NBr	70
2	0.1 M <i>n</i> -Bu ₄ NBr	70
3	0.025 M <i>n</i> -Bu ₄ NBr	57
4	22 second residence time	70
5	4.4 second residence time	47
6	0.2 M EtOH	79
7	0.03 M (50)	56

Unless otherwise stated - MeCN, 80 $\mu\text{l min}^{-1}$ (16.5 sec), 50 mA cm^{-2} , 0.05 M *n*-Bu₄NBr, 0.5 M EtOH

Table: 4.5: Varied reaction conditions in order to optimise the reaction of cyclohexanoamide **50**, with ethanol

As it can be seen, varying the amount of supporting electrolyte didn't have a major effect on product yield (Entries 1-3, Table 4.5). The earlier concerns that flow conditions would not be suitable for use with a catalytic amount of bromine source were correct and the yield was reduced, but not by a considerable amount when using 0.5 equivalents.

When increasing the flow rate, a 23% decrease in yield was observed when the residence time was decreased from 16.5 seconds to 4.4 seconds (Entry 5, Table 4.5),

but no increase in yield was seen when the residence time was increased (Entry 4, Table 4.5). The alcohol content was then increased and the yield increased to 79% (Entry 6, Table 4.5), the maximum yield achieved for the reaction. This being due to a higher concentration of nucleophile available to react with the isocyanate intermediate.

As increasing the flow rate of the reaction caused a decrease in yield, the concentration of the substrate was investigated. It was decreased to 0.03 M (Entry 7, Table 4.5) this also did not have the desired effect of increasing the yield.

In the introduction to this chapter, compound **45** carbaryl, an industrially produced pesticide containing the carbamate linkage is described. It was thought to be an interesting example to be able to reproduce this industrially important compound in the electrochemical flow device (Scheme 4.14). Unfortunately, naphthol led to blockages in the flow cell. Similar difficulties were encountered with other solid alcohols, presumably due to poor solubility in the reaction medium.

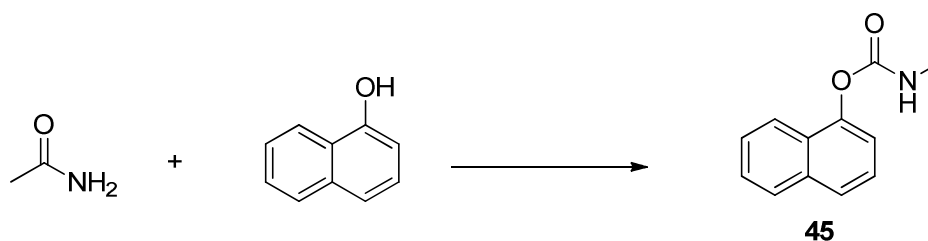

Scheme 4.14: Proposed substrates for production of an industrial pesticide in flow

To try and use a benefit of flow chemistry that is difficult to achieve in a batch electrochemical environment, the use of alcohols as solvents was attempted, namely *n*-BuOH. This would be a difficult solvent to use in a batch environment as longer chain alcohols have lower dielectric constants and a poorer ability to dissolve electrolytes (MeOH $\epsilon = 32.7$, *n*-BuOH $\epsilon = 17.5$ @ 25 °C).¹⁹ The mechanism described by Matsumura *et al.*¹⁸ suggested that using an excess of base in the reaction was the reason for the major side product being observed in batch. This was the case when *n*-BuOH was used as the solvent for the reaction with cyclohexanoamide **50** (Scheme 4.15). Initial experiments to obtain NMR spectra confirmed this and multiplets were visible on the spectra that would correspond to

protons on the cyclohexane rings on the *N*-alkyl-*N'*-acylurea side product. However, efforts to isolate the side products formed was unsuccessful.

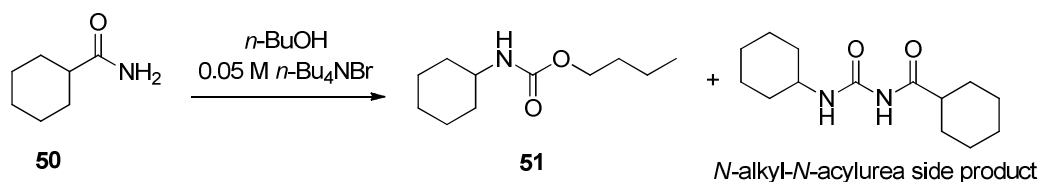

Scheme 4.15: Hofmann rearrangement of **50** using *n*-BuOH as the solvent

The same outcome was observed when ethanol was being used as the solvent, however there was very little conversion of the starting material. Presumed to be due to ethanol being oxidised at the anode. This would cause a competing reaction and inhibiting the formation of the bromonium ion. A maximum isolated yield of the desired carbamate **56** was 11%.

With more work on optimisation, varying residence times, and current densities, it could be possible to increase the yields in all cases. However, this would need to be performed on each substrate as an individual optimisation. As the system had already been proven in batch, with excellent yields the only advantage flow chemistry could add to this would be in continuous processing.

4.3.2 Using electrogenerated bases

To take the idea of the electrogenerated base (EGB) and to come up with a general procedure for the synthesis of isocyanates was the next step. The isocyanates formed could then go on to react in sequential flow reactions to produce either carbamates, ureas, or primary amines depending on the nucleophile used in the sequential reaction. Rather than the alcohol being both the electrogenerated base and as the nucleophile limiting the product formed to carbamates. It was also thought that this method may be applicable to cyclisation reactions. The proposed scheme is shown below (Scheme 4.16).

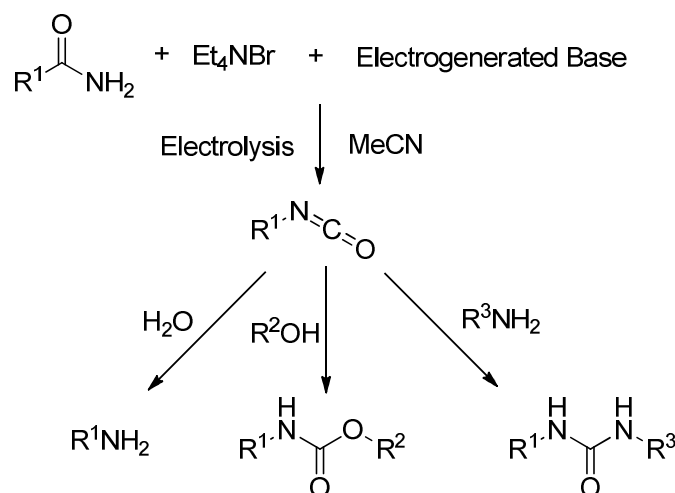

Scheme 4.16: Proposed synthesis using EGB's

Three molecules that had been previously reported as being useful EGB's for numerous organic reactions were chosen; triphenylmethane **59**,²¹ 2-pyrrolidone **60**,^{22,23} and azobenzene **61**²⁴ (Figure 4.2) The formation of the EGB by cathodic reduction of the compound (the probase), gives the anionic species, this is then stabilised by a suitable counterion, present in the reaction as the supporting electrolyte. The formation of the 2-pyrrolidone electrogenerated base is shown below (Scheme 4.17).

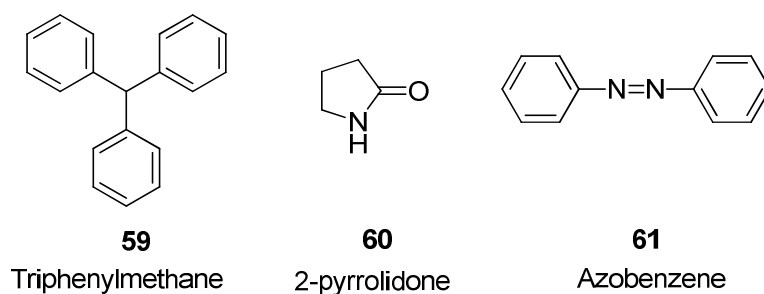
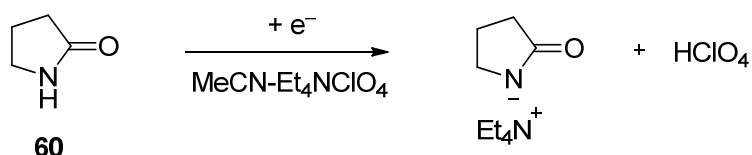

Figure 4.2: Precursors for electrogenerated bases



Scheme 4.17: Formation of 2-pyrrolidone EGB

The reported literature procedures for the reaction of these EGB's showed that there could be problems due to the fact that the EGB reactions were performed in divided cells, and some at low temperatures, although platinum electrodes were used in most cases. The most promising EGB seemed to be **60** because room temperature reactions had been carried out successfully. Hoping that the source of bromine in our reaction system, TEAB/TBAB would be able to act as the bromine source and the tetraalkyl ammonium ion acting as a counterion to the EGB.

Triphenylmethane (**59**), although only reported to work at low temperatures, also seemed to be a good substrate because it would not act as a nucleophile with the isocyanate as 2-pyrrolidone possibly could, and **61** had been reported to give a number of side products.²⁵ The microflow system could possibly overcome these difficulties to carry out a successful reaction, mainly because the close proximity of the electrodes would mean that the ionic species formed during the reactions would only have to be short lived before being able to react with the substrate. The close proximity of the electrodes could also be a negative factor because the reduced species could be almost instantly oxidised if unreacted with the substrate before reaching the anode.

The amide chosen to start the initial reactions was benzamide, which after undergoing the Hofmann rearrangement would give phenyl isocyanate, stable enough to remain in the isocyanate form. With triphenylmethane (**59**), it was reported by Fuchigami *et al.*²¹ that when the trityl anion is being formed a characteristic red colour could be observed. A reaction involving **59** and TBAB in an undivided batch cell was undertaken and it showed that the trityl anion was being generated at -41 °C, however the red colour was only visible for a short amount of time, meaning oxidation at the anode was taking place or protonation of the EGB. As it was being generated in an undivided cell it was possible that the desired reaction could take place in the microreactor.

Efforts to cool the microreactor were found to be ineffective. Cooling it in an ice bath led to leaking of the device, either through the inlet and outlet ports, and/or leaking due to the device being inverted causing a back pressure to build up in the cell. Another method was to cool the reaction solution before entering the device by

immersing the inlet tubing in an ice bath at $-41\text{ }^{\circ}\text{C}$, this method also failed to yield any products.

Unfortunately no reaction occurred with any of the probases mentioned above **59 - 61** to give the desired products after quenching the reaction with an alcohol, amine or water. This meant that the electrogenerated bases could not be formed in a micro-undivided cell as our flow device is, and if so, it was immediately oxidised at the anode before any reaction with the substrate took place.

The nature of the undivided flow cell had proven to be the deciding factor in the failure of the attempted general syntheses. A divided cell would be required to generate the EGB's in flow. Reports of the use of these EGB's show them being formed in a divided cell and then the electrolysis is stopped and the reagents are added. This method could not be used for the electrochemically induced Hofmann rearrangement because both the bromonium oxidising agent and the electrogenerated base need to be formed simultaneously *in situ*.

4.3.3 Oxidation of alcohols in flow

Once having a general procedure for the Hofmann rearrangement in flow, and unable to recreate electrogenerated base syntheses in an undivided flow cell, it was decided to explore more reactions using electrogenerated mediators, as seen in section 4.1.2, where the bromine ion is oxidised at the electrode followed by a chemical reaction with the substrate.

Shono *et al.*²⁶ reported the use of organosulfur compounds, such as thioanisole, as electrogenerated mediators to accomplish the oxidation of secondary alcohols to their corresponding ketones. This method gave them yields (determined by GLC) from 68 – 99% for eight aliphatic secondary alcohols.

The same authors also described the oxidations of both primary and secondary alcohols by the use of KI, with the electrogenerated iodonium acting as the mediator.²⁷ This is the same mediator as the authors used for their reported synthesis of carbamates in the electrochemically induced Hofmann rearrangement.¹⁵ For the 13 aliphatic substrates reacted, yields of 52 – 84% were achieved (Scheme 4.18).

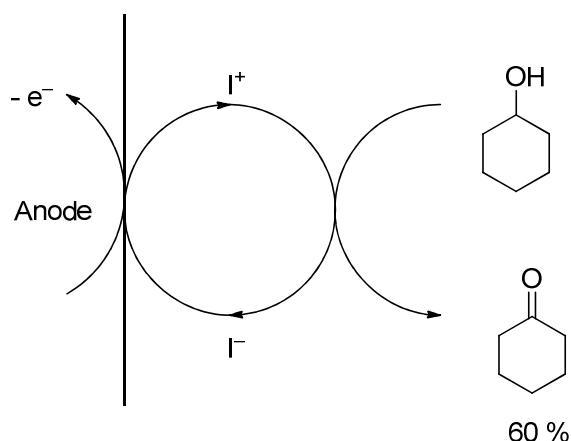

Scheme 4.18: Oxidation of alcohols using iodonium as a catalytic electron carrier

Another reported use of KI being used as an electrochemical mediator for the oxidation of benzyl benzoate (an important pharmaceutical compound as a clinical anti-mutant and in perfumery)²⁸ was reported by Zutshi *et al.*²⁸ and achieved yields of up to 74%, however this was achieved in a divided cell.

The work shown by Shono *et al.*^{26,27} and Zutshi *et al.*²⁸ is an effective method for alcohol oxidations, so work to reproduce results in a flow environment was undertaken. The first component of the reaction that had to be changed, was the inorganic compound KI being used as the mediator. This, in previous reactions was found to cause a tarnishing of the electrode surface during electrolyses. Tetraethylammonium iodide (TEAI) was chosen to replace it, as it had been shown to be successful for oxidations of alcohols.^{26–28}

The first reaction undertaken for optimisation was the oxidation of diphenylmethanol **62** to diphenylmethanone **63** (Scheme 4.19). This was chosen as a substrate as benzylic oxidation is relatively easy to achieve and both chemicals were readily available. TLC monitoring was possible as both compounds **62** and **63** were easily identified.

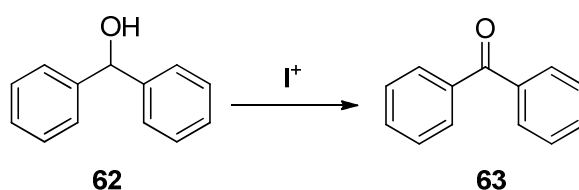

Scheme 4.19: The electrochemical oxidation of diphenylmethanol

In both the work by Shono *et al.*²⁷ and Zutshi *et al.*²⁸ the reaction solvent was water. In both procedures *t*-butyl alcohol was added as a co-solvent to dissolve the substrates when they were not soluble in water.

At first conditions used were as described by Shono *et al.*²⁷ with the exception of 1 equivalent of TEAI being used rather than a catalytic amount. Previous work on the Hofmann rearrangement (Section 4.3.1) had shown that using a less than stoichiometric amount of mediator would lower yields in a flow environment. A concentration of 0.05 M was selected, also proven to be successful with the Hofmann rearrangement, and a ratio of 3:1 H₂O: *t*-BuOH was needed to completely dissolve **62**.

TLC monitoring started at currents between 30 and 150 mA, and residence times from 13 seconds to 2 minutes. At all conditions used, both compounds **62** and **63** were observed for the short length of time needed to ensure homogeneous conditions in the microreactor. However, incomplete conversion of **62** was observed so a larger scale reaction was set-up. It was during longer runs of the reactions (> 2 to 3 minutes), that current supply was interrupted due to the potential increasing until the potentiostat stopped supplying current and electrolyses stopped. After dismantling the device, a brown solid was observed that had formed in the channel and completely blocked it during the reaction.

The solvent was then changed to acetonitrile, and the same blocking of the channel was observed. To overcome this, a solvent system of MeCN : H₂O (9:1) was used. This enabled the reaction to proceed for long periods of time without any disruption of current or blocking of the channel, but at very low flow rates, and/or high currents, disruption of current to the system still occurred.

TLC was used to monitor the reaction, but again both starting material and product were visible under all conditions. A compromise between flow rate and current was chosen to run a larger scale experiment so column chromatography could be used to isolate the product. Under the conditions shown (Scheme 4.20), a yield of 59% was achieved with the remainder being **62**. As only the product was being formed **63**, no side products were visible during the reaction.

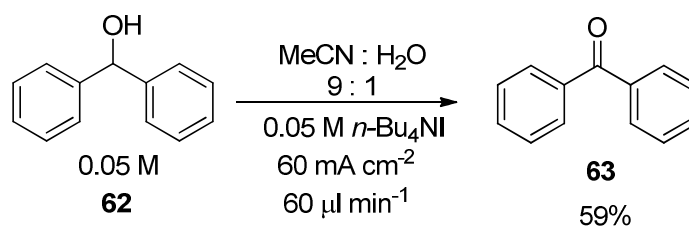

Scheme 4.20: Conditions for the electrochemical oxidation of diphenylmethanol in flow

As monitoring the reaction by TLC to look for complete conversion of the starting material had proven ineffective for this reaction, the substrate chosen for the next experiment was benzylalcohol **64** to benzylbenzoate **65** (Scheme 4.21). This was for the ability to monitor the reaction from NMR spectra obtained at different reaction conditions, while this was not possible for the previous reaction.

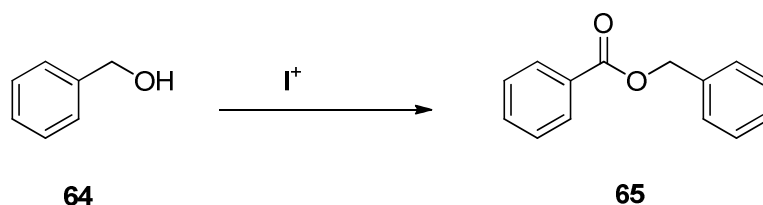

Scheme 4.21: The electrochemical oxidation of benzyl alcohol in flow

The reaction (Scheme 4.21) had been reported by Zutshi *et al.*²⁸ on a carbon anode, again with water as the solvent. So the reaction conditions were kept as developed for the synthesis of **63** (Scheme 4.20), as this had been proven successful in our microflow device, unlike the previously reported conditions.

Initial reactions were started with a concentration of 0.05 M and a range of flow rates between 40 and 80 μl min⁻¹, and currents between 60 and 100 mA cm⁻², with no formation of **65** being observed. The main peak in the NMR spectra was that of the starting material, although there were traces of the side product, benzaldehyde.

To obtain a conversion to the product, another equivalent of TBAI was added, so there was no need for the iodonium to be regenerated during the reaction for the second oxidation step, from benzaldehyde to **65**. This was also ineffective, and the reaction remained unsuccessful. Very little starting material was converted, and none of the desired product was observed. A batch reaction was undertaken with platinum

electrodes in an undivided cell as the work by Zutshi *et al.*²⁸ had been carried out in a divided cell. Again no formation of the desired product was observed, confirming that the product could not be formed in an undivided cell with platinum electrodes.

Cyclopentanol **66** was the next substrate chosen (Scheme 4.22), with the same conditions as for the conversion of **62** to **63**, 0.05 M with a flow rate of 60 $\mu\text{l min}^{-1}$, current density of 60 mA cm^{-2} and 1 equivalent of TEAI. Only 25% pentanone **67**, was isolated, again with the remainder of **66** being recovered. This shows again, that the same conditions cannot be applied to different substrates to achieve the same results.

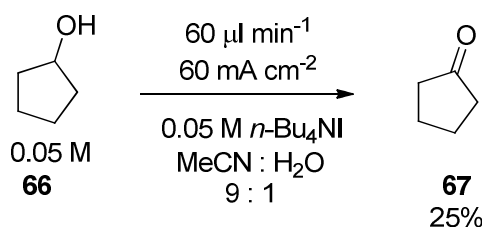

Scheme 4.22: Oxidation of cyclopentanol in flow

4.4 Conclusions

The microreactor device has been shown to be a successful method for indirect electrochemical reactions. Both the Hofmann rearrangement and the oxidation of secondary alcohols is possible from the oxidation of halide ions, giving the halonium ion as the oxidising species in solution. Creating a general set of reaction conditions to achieve optimum yields for the different alcohol being used was not possible. Each substrate would need to be optimised individually for maximum yields to be achieved. Reasonable yields were achieved for a set of compounds which could be run continuously if large amounts of the desired compounds was needed.

With regards to electrogenerated bases, unless the cell could be modified to be able to carry out divided cell synthesis, then it is not a feasible synthesis to be carried out in the device.

The oxidation of secondary alcohols could also possibly be optimised to a higher yielding synthesis than the results described here. Possible online analysis or HPLC

analysis could be used to monitor the ratio of starting material to products to allow for a quantitative conversion to the product.

More reactions would need to be carried out on primary alcohols to find out if the substrate needed to be reacted in a divided cell as reported, to stop the substrate reacting directly with the anode, or if primary alcohols in general cannot be converted into the corresponding ester in a flow cell.

4.5 Experimental

Melting points were obtained in open capillary tubes and are uncorrected. ^1H NMR and ^{13}C NMR spectra were recorded on an AV-400 Bruker spectrometer, in the solvents indicated at 400 and 100 MHz, respectively, unless otherwise stated. Mass spectra were recorded under the conditions of fourier transform mass spectrometry (FTMS) Nanospray ionisation (NSI). Galvanostatic reactions were performed with a GW INSTRON GPR-30H10D galvanostat/potentiostat. No polishing of electrodes was needed, only cleaning with acetone was necessary. Acetonitrile was dried *via* a solvent purification system (SPS) and methanol, and ethanol dried over 4 Å molecular sieves, all other chemicals were used as purchased without further purification.

NMR experiments consist of running small volumes (3 – 4 ml) of reaction solution through the device. A normal work-up procedure would then be undertaken with the exception of a deuterated solvent being used for extraction so ^1H NMR spectra can be obtained directly.

General reaction procedure for the Hofmann rearrangement

A 0.05 M solution of amide **50**, containing 0.05 M tetrabutylammonium bromide and the alcohol (0.5M) in acetonitrile was made (10 ml solution) and introduced into the electrochemical microreactor (reactor volume 22 μL) *via* a syringe pump (flow rate 80 $\mu\text{l min}^{-1}$ / residence time 16.5 seconds) with an applied current of 50 mA cm^{-2} . The reaction was allowed to reach equilibrium and the solution was collected at the outlet. The solvent was removed *in vacuo* and the resulting residue was dissolved in CH_2Cl_2 , washed twice with water, and once with brine. The organic layer was then dried through a phase separator and concentrated *in vacuo*. The residue was

subjected to flash column chromatography (*n*-hexane – ethyl acetate) to give the desired carbamate **51** – **58**.

Butyl cyclohexylcarbamate (**51**)²⁹ - (9.6 ml collected in 120 mins to give 65 mg, 68%).

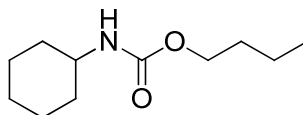

White solid, m.p.: 51-52 °C (lit. 51 – 55 °C); ¹H NMR (400 MHz, CDCl₃): δ = 0.86 (t, *J* = 7.4 Hz, 3H, CH₃), 1.06-1.19 (m, 3H, cyclohexyl), 1.24-1.35 (m, 4H, 2 x cyclohexyl CH₂), 1.56-1.61 (m, 3H, cyclohexyl), 1.66-1.71 (m, 2H, cyclohexyl CH₂), 1.88-1.93 (m, 2H, cyclohexyl CH₂), 3.39-3.46 (m, 1H, cyclohexyl CH), 3.69 (t, *J* = 6.3 Hz, 2H, O-CH₂), 4.46 (br s, 1H, NH) ppm; ¹³C NMR (100 MHz, CDCl₃): δ = 13.7 (CH₃), 19.0 (CH₂), 24.7 (2 x cyclohexyl CH₂), 25.4 (2 x cyclohexyl CH₂), 31.1 (cyclohexyl CH₂), 33.4 (CH₂), 49.6 (cyclohexyl CH), 64.4 (O-CH₂), 155.9 (C=O) ppm; FTMS NSI [M + H⁺] calcd. for C₁₁H₂₂NO₂ = 200.1645; found - 200.1642.

Isopropyl cyclohexylcarbamate (**52**)³⁰ – (9.8 ml collected in 123 mins to give 61 mg, 69%).

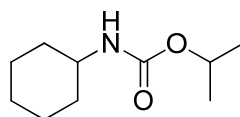

Yellow solid, m.p.: 61-63 °C (lit. 65 – 67 °C); ¹H NMR (400 MHz, CDCl₃): δ = 1.05-1.16 (m, 3H, cyclohexyl), 1.21 (d, *J* = 6.2 Hz, 6H, 2 x CH₃), 1.26-1.38 (m, 2H, cyclohexyl), 1.54-1.61 (m, 1H, cyclohexyl), 1.65-1.71 (m, 2H, cyclohexyl), 1.89-1.92 (m, 2H, cyclohexyl), 3.41-3.51 (m, 1H, cyclohexyl CH), 4.47 (br s, 1H, NH), 4.88 (m, 1H, O-CH) ppm; ¹³C NMR (100 MHz, CDCl₃): δ = 22.1 (2 x CH₃), 24.7 (2 x cyclohexyl CH₂), 25.4 (2 x cyclohexyl CH₂), 33.4 (cyclohexyl CH₂), 49.5 (cyclohexyl CH), 67.6 (O-CH), 155.4 (C=O) ppm; FTMS NSI [M + H⁺] calcd. for C₁₀H₂₀NO₂ = 186.1489; found - 186.1487.

2,2,2-Trifluoroethyl cyclohexylcarbamate (**53**)³¹ - (9.5 ml collected in 118 mins to give 27 mg, 25%).

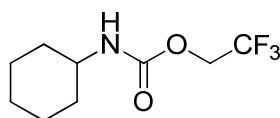

White solid, m.p.: 79-80 °C (lit. 80 – 81 °C); ¹H NMR (400 MHz, CDCl₃): δ = 1.10-1.21 (m, 3H, cyclohexyl), 1.29-1.40 (m, 2H, cyclohexyl), 1.58-1.63 (m, 1H, cyclohexyl), 1.68-1.74 (m, 2H, cyclohexyl), 1.92-1.96 (m, 2H, cyclohexyl), 3.44-3.54 (m, 1H, cyclohexyl CH), 4.43 (q, ³J_{H,F} = 8.5 Hz, 2H, O-CH₂), 4.77 (br s, 1H, NH) ppm; ¹³C NMR (100 MHz, CDCl₃): δ = 24.9 (2 x cyclohexyl CH₂), 25.6 (2 x cyclohexyl CH₂), 33.3 (cyclohexyl CH₂), 50.5 (cyclohexyl CH), 60.9 (q, J = 36.3, CF₃), 123.4 (q, ²J_{C,F} = 277), 153.4 (C=O) ppm; FTMS NSI [M + NH₄⁺] calcd. for C₉H₁₄F₃NO₂NH₄ = 243.1315; found – 243.1316.

Methyl cyclohexylcarbamate (**54**)³² - (9.3 ml collected in 116 mins to give 47 mg, 64%)

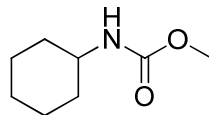

White solid m.p.: 70-75 °C (lit. 69 - 72 °C); ¹H NMR (400 MHz, CDCl₃): δ = 1.06-1.19 (m, 3H, cyclohexyl), 1.23-1.37 (m, 2H, cyclohexyl), 1.55-1.61 (m, 1H, cyclohexyl), 1.66-1.71 (m, 2H, cyclohexyl), 1.89-1.92 (m, 2H, cyclohexyl), 3.45-3.47 (m, 1H, cyclohexyl CH), 3.63 (s, 3H, CH₃), 4.57 (br s, 1H, NH) ppm; ¹³C NMR (100 MHz, CDCl₃): δ = 24.7 (2 x cyclohexyl CH₂), 25.4 (2 x cyclohexyl CH₂), 33.4 (cyclohexyl CH₂), 49.7 (CH₃), 51.7 (cyclohexyl CH), 156.1 (C=O) ppm; FTMS NSI [M + H⁺] calcd. for C₈H₁₆NO₂ = 158.1176; found – 158.1173.

Benzyl cyclohexylcarbamate (**55**)³³ - (9.6 ml collected in 120 mins to give 56 mg, 50%).

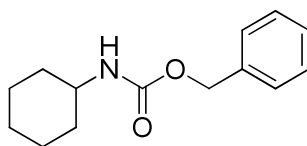

White solid m.p.: 87-89 °C (lit. 93 - 96 °C); ¹H NMR (400 MHz, CDCl₃): δ = 1.07-1.20 (m, 3H, cyclohexyl), 1.25-1.39 (m, 2H, cyclohexyl), 1.56-1.60 (m, 1H, cyclohexyl), 1.66-1.72 (m, 2H, cyclohexyl), 1.91-1.94 (m, 2H, cyclohexyl), 3.49-3.51 (m, 1H, cyclohexyl CH), 4.64 (br s, 1H, NH), 5.08 (s, 2H, benzyl CH₂), 7.28-7.36 (m, 5H, 5 x CH) ppm; ¹³C NMR (125 MHz, CDCl₃): δ = 24.7 (2 x cyclohexyl CH₂), 25.5 (2 x cyclohexyl CH₂), 33.4 (cyclohexyl CH₂), 49.9 (cyclohexyl CH), 66.4 (O-CH₂), 126.0 (2 x CH_{Ar}), 126.1 (CH_{Ar}), 128.5 (2 x CH_{Ar}), 136.7 (C_{Ar}), 155.3 (C=O) ppm; FTMS NSI [M + H⁺] calcd. for C₁₄H₂₀NO₂ = 234.1489; found – 234.1488

Ethyl cyclohexylcarbamate (**56**)³³ - (9.5 ml collected in 118 mins to give 57 mg, 70%).

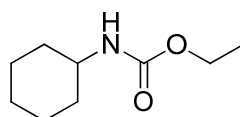

White solid m.p.: 49-51 °C (lit. 54 - 59 °C); ¹H NMR (400 MHz, CDCl₃): δ = 1.06-1.39 (m, 8H, cyclohexyl + CH₃), 1.56-1.71 (m, 3H, cyclohexyl), 1.90-1.94 (m, 2H, cyclohexyl), 3.46-3.48 (m, 1H, cyclohexyl CH), 4.09 (q, *J* = 6.6 Hz, 2H, O-CH₂), 4.51 (br s, 1H, NH); ¹³C NMR (125 MHz, CDCl₃): δ = 14.6 (CH₃), 24.8 (2 x cyclohexyl CH₂), 25.5 (2 x cyclohexyl CH₂), 33.5 (cyclohexyl CH₂), 49.7 (cyclohexyl CH), 60.5 (O-CH₂), 155.3 (C=O) ppm; FTMS NSI [M + H⁺] calcd. for C₉H₁₈NO₂ = 172.1332; found – 172.1330.

Ethyl (4-methoxyphenyl)carbamate (**57**)³⁰ - (9.2 ml collected in 115 mins to give 26 mg, 29%).

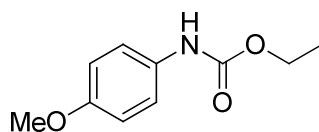

Yellow oil, ¹H NMR (500 MHz, CDCl₃): δ = 1.37 (t, *J* = 7.1 Hz, 3H, CH₃), 3.85 (s, 3H, O-CH₃), 4.34 (q, *J* = 7.1 Hz, 2H, CH₂), 6.90 (d, *J* = 8.8 Hz, 2H, 2 x CH), 7.99 (d, *J* = 8.8 Hz, 2H, 2 x CH) ppm; ¹³C NMR (125 MHz, CDCl₃): δ = 14.3 (CH₃), 55.4 (O-CH₃), 60.6 (O-CH₂), 113.5 (2 x CH_{Ar}), 123.0 (C_{Ar}), 131.5 (2 x CH_{Ar}), 163.2 (C_{Ar}), 166.3 (C=O) ppm; FTMS NSI [M + H⁺] calcd. for C₁₀H₁₄NO₃ = 196.0968; found – 196.0967.

Ethyl (3-fluorophenyl)carbamate (**58**) - (9.5 ml collected in 118 mins to give 19 mg, 22%).

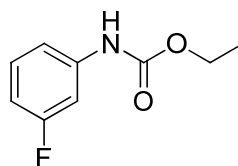

Yellow oil, ¹H NMR (400 MHz, CDCl₃): δ = 1.30 (t, *J* = 7.1 Hz, 3H, CH₃), 4.12 (q, *J* = 7.1 Hz, 2H, CH₂), 6.66 (br, s, NH), 6.74 (m, 1H, CH), 7.01 (d, *J* = 8.1 Hz, 1H, CH), 7.22 (dt, *J* = 6.7, 8.2, 1H, CH), 7.36 (d, *J* = 10.8, 1H, CH) ppm; ¹³C NMR (125 MHz, CDCl₃): δ = 14.4 (CH₃), 61.4 (O-CH₂), 106.0 (d, C_{Ar}, ³*J*_{C,F} = 26.5 Hz), 110.0 (d, C_{Ar}, ³*J*_{C,F} = 21.3 Hz), 113.8 (C_{Ar}), 130.0 (d, C_{Ar}, ²*J*_{C,F} = 9.5 Hz), 139.6 (d, C_{Ar}, ²*J*_{C,F} = 11.1 Hz), 165.3 (C=O), 163.2 (d, F-C_{Ar}, ¹*J*_{C,F} = 244.5) ppm; FTMS NSI [M + H⁺] calcd. for C₉H₁₁FNO₂ = 184.0768; found – 184.0767)

General reaction procedure for oxidation of alcohols

A 0.05 M solution of an alcohol in acetonitrile : H₂O (9 : 1) containing 0.05 M TBAI was made (10 ml solution) and introduced into the electrochemical microreactor (reactor volume 22 μL) *via* a syringe pump (flow rate 0.06 ml min⁻¹ / residence time 22 seconds) with an applied current of 60 mA cm⁻² and the reaction was allowed to reach equilibrium. The solution was collected at the outlet. The solvent was then removed *in vacuo* and the resulting residue was dissolved in CH₂Cl₂ and washed

twice with water, and once with brine. The organic layer was then dried through a phase separator and concentrated *in vacuo*. The residue was subjected to flash column chromatography (*n*-hexane – ethyl acetate) to give the desired ketone **63** or **67**.

Diphenylmethanone (**63**)³⁴ - (9.6 ml collected in 120 mins to give 51 mg).

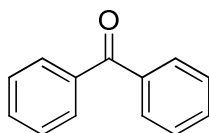

White solid m.p.: 45 - 47 °C (lit. 48 - 49 °C); ¹H NMR (400 MHz, CDCl₃): δ = 7.46-7.50 (m, 4H), 7.57-7.61 (m, 2H), 7.79-7.82 (m, 4H) ppm; ¹³C NMR (100 MHz, CDCl₃): δ = 128.2 (4 x CH_{Ar}), 130.0 (4 x CH_{Ar}), 132.3 (2 x CH_{Ar}), 137.5 (2 x CH_{Ar}), 196.7 (C=O) ppm.

Cyclopentanone (**67**)³⁴ - (9.5 ml collected in 118 mins to give 10 mg).

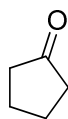

Colourless oil; ¹H NMR (500 MHz, CDCl₃): δ = 1.94-1.97 (m, 4H, 2 x CH₂), 2.14-2.17 (m, 4H, 2 x CH₂) ppm; ¹³C NMR (125 MHz, CDCl₃): δ = 38.3 (2 x CH₂), 23.2 (2 x CH₂), 220.4 (C=O) ppm; IR (neat) 1739 cm⁻¹ (C=O)

4.6 References

1. Y. Deng, F. Shi, T. SiMa, J. Peng, Y. Gu, and B. Qiao, *Angew. Chemie, Int. Ed. English*, **2003**, *42*, 3257.
2. H. Babad and A. G. Zeiler, *Chem. Rev.*, **1972**, *73*, 75.
3. H. Eckert, *Chim. Oggi*, **2011**, *29*, 1.
4. D. Chaturvedi, *Tetrahedron*, **2012**, *68*, 15.
5. S. J. Brickner, M. R. Barbachyn, D. K. Hutchinson, and P. R. Manninen, *J. Med. Chem.*, **2008**, *51*, 1981.
6. A. Brossi, *J. Med. Chem.*, **1990**, *33*, 2311.

7. A. Montoya and A. Abad, *J. Agricultural Food Chem.*, **1994**, *42*, 1818.
8. T. Laue and A. Plagens, *Named organic reactions*, Wiley-Blackwell, 2nd edn., 2005.
9. M. Meier, O. Kreye, and H. Mutlu, *Green Chem.*, **2013**, *15*, 1431.
10. W. Keillir and X. Huang, *Tetrahedron Lett.*, **1997**, *38*, 313.
11. J. W. Keillor, X. Huang, and M. Seid, *J. Org. Chem.*, **1997**, *62*, 7947.
12. R. Moriarty, C. Chany II, R. Vaid, O. Prakash, and S. Tuladhar, *J. Org. Chem.*, **1993**, 2478.
13. P. Gogoi and D. Konwar, *Tetrahedron Lett.*, **2007**, *48*, 531.
14. S. V. Ley, A. Palmieri, K. Hammond, A. Polyzos, and I. R. Baxendale, *Tetrahedron Lett.*, **2009**, *50*, 3287.
15. T. Shono, Y. Matsumura, S. Yamane, and S. Kashimura, *Chem. Lett.*, **1982**, *11*, 565.
16. W. Haynes, *CRC Handbook of Chemistry and Physics*, CRC Press, 94th edn., 2013.
17. Y. Matsumura, T. Maki, and Y. Satoh, *Tetrahedron Lett.*, **1997**, *38*, 8879.
18. Y. Matsumura, Y. Satoh, T. Maki, and O. Onomura, *Electrochim. Acta*, **2000**, *45*, 3011.
19. H. Lund and O. Hammerich, *Organic Electrochemistry*, CRC Press, 4th edn., 2001.
20. H. House, E. Feng, and N. Peet, *J. Org. Chem.*, **1970**, *36*, 2371.
21. T. Fuchigami, K. Suzuki, and T. Nonaka, *Electrochim. Acta*, **1989**, *35*, 239.
22. T. Shono, S. Kashimura, M. Sawamura, and T. Soejima, *J. Org. Chem.*, **1988**, *53*, 907.
23. M. Feroci, A. Inesi, and L. Rossi, *Tetrahedron Lett.*, **2000**, *41*, 963.
24. A. Freitas, A. Bettencourt, and M. Montenegro, *Tetrahedron Lett.*, **1999**, *40*, 4397.
25. M. Feroci, A. Inesi, L. Palombi, L. Rossi, and G. Sotgiu, *J. Org. Chem.*, **2001**, *66*, 6185.

26. T. Shono, M. Matsumura, Mizoguchi, and J. Hayashi, *Tetrahedron Lett.*, **1979**, 40, 3861.
27. T. Shono, Y. Matsumura, J. Hayashi, and M. Mizoguchi, *Tetrahedron Lett.*, **1979**, 2, 165.
28. K. Zutshi, G. Dixit, and R. Rastogi, *Electrochim. Acta*, **1981**, 27, 561.
29. Y. Deng, L. Lu, X. Ma, S. Liu, and J. Shang, *Green Chem.*, **2012**, 14, 2899.
30. L. Rossi, A. Inesi, and V. Mucciante, **1998**, 3263, 1337.
31. A. Shivanyuk, A. V Bogolubsky, S. V Ryabukhin, S. E. Pipko, O. Lukin, D. Mykytenko, and A. Tolmachev, *Tetrahedron*, **2011**, 67, 3619.
32. X. Hu, P. Liu, and Z. Wang, *European J. Org. Chem.*, **2012**, 1994.
33. G. Prasanta and B. Gopal, *Org. Biomol. Chem.*, **2013**, 11, 4397.
34. S. Miller, J. Grill, and J. Ogle, *J. Org. Chem.*, **2006**, 71, 77843.

Chapter 5

Electrochemical Trifluoromethylation of Olefins in Flow

5.1 Introduction

5.1.1 Fluorine in nature and society

Since the discovery of elemental fluorine by Moissan in 1886, organofluorine chemistry had a slow start to become the field of great importance it is today. Fluorine has a wide variety of uses in today's society ranging from pharmaceuticals to LCD screens for phones and televisions due to the highly reactive nature of elemental fluorine and its unique properties.

There are approximately 3700 naturally occurring organohalogens and although fluorine is the 13th most abundant element in the earth's crust, very few naturally occurring compounds have a fluorine molecule incorporated into them :-

Organochlorines – 2150

Organobromines – 1850

Organoiodines – 95

Organofluorines – 30

There are two natural processes that give rise to organohalogens, biogenic, and abiogenic. The first are processes from plants and animals, while the latter are from geothermal processes. There are a few plants that can take fluoride and convert it into fluoroacetate (fluoroacetic acid **68**), which is highly toxic, and other fluorocarboxylic acids. Fluoroacetate was the first compound to be isolated and characterised from the plant *Dichapetalum cymosum* in 1943. Another example is fluorocitrate (**69**), which again is isolated as a result of biogenic processes in plants. Fluorocitrate (**69**) is found in day-to-day life, although below toxic levels, in commercial tea leaves and oatmeal, however the only toxic isomer has the (2*R*,3*R*) configuration (**69**) (Figure 5.1). As a result of abiogenic processes, fluoroalkanes have been isolated from volcanic and other geothermal gases. A major component of volcanic gases is hydrogen fluoride while gases such as fluoroethylene **70**, and hexafluoropropene **71**, have also been isolated (Figure 5.1).¹ More recently Kraus *et al.*² have proven the existence of elemental F₂ in

nature. Naturally occurring fluorite, CaF_2 , has been used since the medieval ages, and in the 1670's was used for the production of frosted glass. Fluorite is also known as "antozonite" due to its bad odour when crushed. While irradiating their sample with β and γ lasers, the authors found that the blue colour was caused by Ca clusters, and the gas given off was unambiguously determined as authentic F_2 .

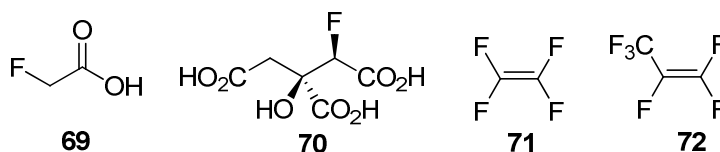

Figure 5.1: Naturally occurring fluorine containing compounds

It wasn't until Swartz discovered that antimony trifluoride (SbF_3), allowed for the conversion of chlorocarbons to fluorocarbons (Scheme 5.1) at the end of the 19th century that synthetic organofluorine chemistry really took off. There are so few naturally occurring fluorine containing compounds which makes this area of chemistry almost completely synthetic.^{3,4}



Scheme 5.1: Conversion of hydrocarbons to fluorocarbons

It was Midgely, while working for the Frigidaire Corporation, that took the discovery of fluorocarbons and synthesised chlorofluorocarbons (CFC's) (Scheme 5.2) and gave them a commercial use as refrigerants. The most widely used being known as Freon®. Their non-toxic and non-flammable properties made them excellent candidates to replace the toxic chemicals being used at the time such as ammonia. Although they are quite volatile compounds, they are less volatile than the corresponding alkanes and inevitably more dense due to the addition of heavier halogen atoms. These properties also made CFC's very appealing for a use as extinguishers, along with the ability of chlorine or bromine atoms present in the molecules to quench radicals that sustain the chain reaction required for a fire to continue burning. However it was some years later that Molina and Rowland released their ozone-depletion hypothesis, revealing that

ultraviolet light in the stratosphere was causing the CFC's to decompose to radicals which in turn react with ozone creating oxygen and as a result the worldwide ban of CFC's was introduced.^{4,5,6}

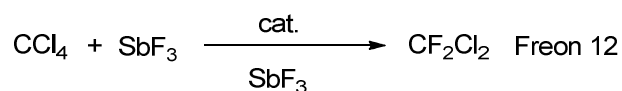

Scheme 5.2: Midgely's synthesis of CFC's

It was research into refrigerants that also gave birth to polytetrafluoroethylene (PTFE), known commercially as Teflon®. It is a polymer consisting of a carbon chain with the outside of the molecule being all fluorine atoms, it is this that repels all other molecules that it comes into contact with giving it excellent properties in day to day uses such as non-stick frying pans.

Another important part of our day to day lives has been vastly improved by the incorporation of fluorine into molecules, the area of liquid crystalline displays, for such technologies as mobile telephones, televisions and computer screens. The main function of adding fluorine into these molecules was to add a dipole moment, this is an essential function of the molecules as it allows for switching when an electric current is applied. For many years fluorine was added to the aromatic parts of the liquid crystals. More recent research into the compounds has evolved to incorporating fluorinated bridges connecting the cyclic substituents of the molecule. These bridges have improved properties of the materials such as the nematic phase range and the clearing temperatures of the molecules.^{6,7}

In the 1970's Gray *et al.* synthesised the first stable liquid crystals that possessed a room temperature nematic phase, containing a terminal cyano group. However, these compounds did not meet the specific requirements for active matrix displays even after purification. This led to a number of fluorine containing compounds being developed to increase the nematic phase range of the compounds.⁸ Some examples of liquid crystal compounds used today are shown below (Figure 5.2).⁸

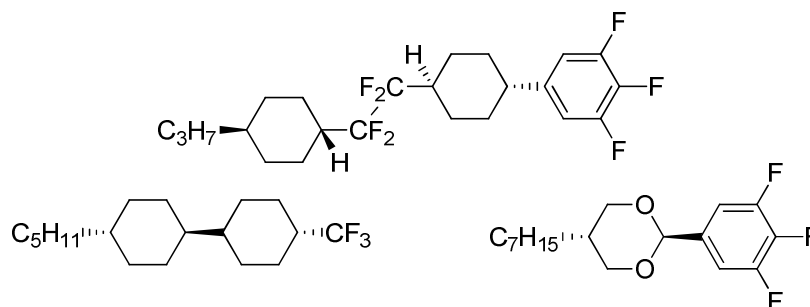

Figure 5.2: Nematic liquid crystal structures

5.1.2 Fluorine in medicine

Fluorine is arguably the most reactive element in the periodic table, being able to react with every other element with the exceptions of He and Ne. The addition of fluorine to an organic compound can change the properties of the compound greatly as well as the compounds bioactivity, making it very attractive for the pharmaceutical industry with more than 20% of the pharmaceuticals, and more than 30% of all agrochemicals available on the market today containing at least one fluorine atom. Two of the top selling pharmaceuticals on the market today are shown below (Figure 5.3), fluoxetine (Prozac® **72**) used as an anti-depressant, and the antibacterial ciprofloxacin (Ciprobay® **73**). One of the most important contributions of fluorine to the field of medicine was the invention of fluorine based anaesthetics. The first of these compounds was Fluoroxene, ($\text{CF}_3\text{CF}_2\text{OCH}=\text{CH}_2$) which replaced the use of the highly flammable diethyl ether.^{4,5,9,10}

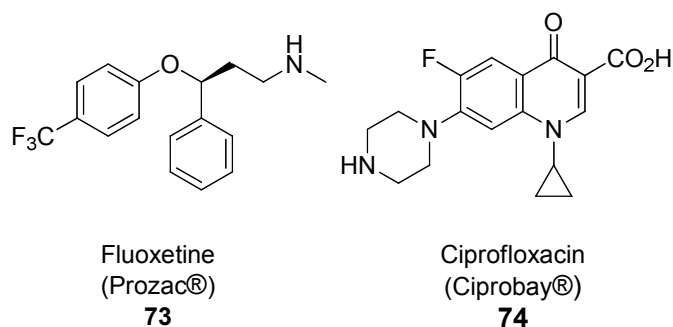

Figure 5.3: Fluorine containing pharmaceuticals

The bond dissociation energies of the halogens decrease down the group as the atomic size increases with the exception of fluorine. Its high reactivity can be attributed to the low dissociation energy of the F-F bond because of the strong inter electronic repulsions present (158.8 kJmol^{-1}) and the strong bond interactions of fluorine to other elements (Table 5.1).¹¹ The low bond dissociation energy is due to its electronic configuration, consisting of an unshielded high nuclear charge which holds the surrounding electrons tightly. This makes completing its outer shell with electrons favourable with either a covalent bond or a fluoride anion being formed.⁹

X	XX	HX	BX₃	AlX₃	CX₄
F	159	574	645	582	456
Cl	243	428	444	427	327
Br	193	363	368	360	272
I	151	294	272	285	239

Table 5.1: Bond energies of some halogen bonds (kJmol^{-1})

Another important property of adding fluorine to a compound is its high electronegativity. It is the most electronegative element in the periodic table with a Pauling electronegativity value of 3.98 and this can have a big impact on the acidities of neighbouring functional groups. A large number of the drugs available today contain at least one basic nitrogen atom. The likelihood of this nitrogen being protonated in biological systems is critical for the binding potency to the target but also to other properties such as the lipophilicity, and membrane permeability making it important to not only know the $\text{p}K_{\text{a}}$ of the compound, but also to be able to vary the basicity of the compound by the addition of functional groups that can alter this (Table 5.2).^{12,13}

Carboxylic acid	p<i>K</i>_a	Alcohol	p<i>K</i>_a	Amine	p<i>K</i>_b
CH ₃ CO ₂ H	4.76	CH ₃ CH ₂ OH	15.9	CH ₃ CH ₂ NH ₂	10.6
CH ₂ FCO ₂ H	2.59	CF ₃ CH ₂ OH	12.4	CF ₃ CH ₂ NH ₂	5.7
CHF ₂ CO ₂ H	1.34	(CH ₃) ₃ COH	19.2	C ₆ H ₅ NH ₂	4.6
CF ₃ CO ₂ H	0.52	(CF ₃) ₃ COH	5.1	C ₆ F ₅ NH ₂	-0.36

Table 5.2: Effects of fluorine addition on p*K*_a and p*K*_b

The lipophilicity of a molecule is also an important factor in pharmaceuticals, expressed as a partition coefficient (log *P*) between octanol and water. In order for a drug molecule to be able to pass through the cell membrane it must have sufficient lipophilicity, on the other hand it cannot be so lipophilic that it gets trapped inside the lipid core which can cause incomplete absorption of the drug. The addition of fluorine will not always increase the lipophilicity of a molecule. Mono- or trifluorination of molecules often has the opposite effect due to the relatively polar characteristics and strong bond dipoles. When fluorine is attached to an aromatic ring, next to atoms with π -bonds, or in per/polyfluorinated molecules, lipophilicity is increased. This is due to the strong overlap between the fluorine 2s or 2p orbitals with the corresponding orbitals on carbon, (Table 5.3) with the trifluoromethyl group being one of the most lipophilic known.^{12,14}

Compound	Log <i>P</i> (octanol - water)
CH ₃ CH ₃	1.81
CH ₃ CHF ₂	0.75
CH ₃ (CH ₂) ₃ CH ₃	3.11
CH ₃ (CH ₂) ₃ CH ₂ F	2.33

Table 5.3: Effects of fluorine addition on lipophilicity

Fluorine is substituted into many molecules as a replacement for hydrogen but the two molecules differ with both size and stereoelectronic properties. It has been shown that the size of a trifluoromethyl group is more similar in size to an ethyl group than a hydrogen atom. However the shapes are very different and can lead to conformational changes to the molecule in which it is contained. This can be shown with

methoxybenzene and trifluoromethoxybenzene as examples. The methoxy group of the former lies in the plane of the phenyl ring, attributed to p orbital of the oxygen being sp^2 -hybridised and conjugated to the aromatic π system. In contrast due to the steric size and electronic properties of the trifluoromethoxy group it is orientated out of the plane. This effect has been used to great effect and allowed the design of superior inhibitors of the cholesteryl ester transfer protein. When exchanging a tetrafluoroethoxy group (-OCF₂CF₂H) for an ethoxy group an 8-fold loss in potency in one such inhibitor was observed due to more efficient binding to the target site with the out of plane conformation.^{10,12,14}

Another major advantage of incorporating fluorine into medicine arises because of the ¹⁸F radionucleus. Positron emission tomography (PET) is an imaging process used to not only show anatomic information, but PET tracers are also capable of showing biological processes and can give metabolic information. The most popular PET tracer is FDG (2-deoxy-2-[¹⁸F]fluoro-D-glucose). The advantage the ¹⁸F tracers have is the elongated half-life compared to other short-lived radio nuclei. It has a half-life of 110 minutes compared with that of ¹⁵O (2 minutes), ¹³N (10 minutes), and ¹¹C (20 minutes). This means that the time from production in the cyclotron, to being administered to the patient is much easier to achieve. The ¹⁸F decays to ¹⁸O in the body and can then be excreted as glucose. PET tracers like FDG have now been synthesised in multi-step reaction sequences in microreactors, shortening the reaction times and increasing the amount of time the substance can be used before it is not useful to be used as a medical tracer.^{4,12,15}

5.2. Methods of Fluorination

5.2.1 Direct Fluorination

Having discussed some of the properties and uses in the many fields of chemistry that fluorine has been utilised, it is easy to see why so many people have tried to make safer methods and reagents for incorporating a fluorine atom into a molecule other than using elemental fluorine. However elemental fluorine was the only source of electrophilic fluorine available for many years and it has been used to great effect since its dilution

with inert gases, such as nitrogen, in the 1960's. This in conjunction with low temperatures made it much easier to handle. An early example where it was used to great effect, and one of the few industrial processes using elemental fluorine, is the synthesis of 5-fluorouracil (**75**), a compound used in the treatment of several types of cancer. It is synthesised by addition of fluorine to the double bond of the pyrimidine. When carried out in acetic acid as the solvent, an unstable acetoxy intermediate is formed which when heated will give **75** (Scheme 5.3).^{9,16}

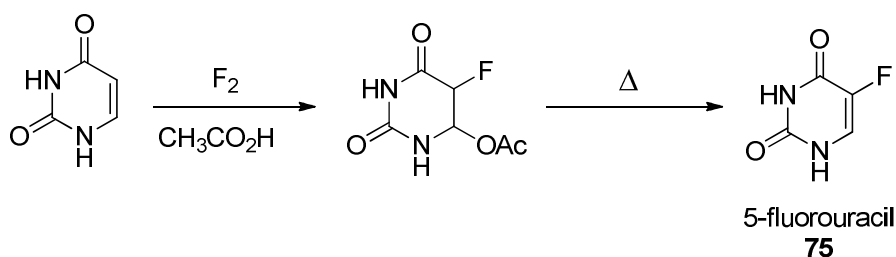

Scheme 5.3: Synthesis of 5-Fluorouracil **75**

The two main methods for addition of fluorine to a molecule in organic synthesis are the direct fluorination or the synthetic “building block” approach. The former uses nucleophilic or electrophilic fluorine containing reagents or fluorine radicals, whereas the latter uses molecules such as trifluoroacetic acid, already containing a C-F bond to be incorporated into the molecule. There are few examples of direct fluorination reactions involving fluorine radicals due to the scarcity of safe sources of atomic fluorine ($F\cdot$).

Nucleophilic fluorinating reagents are sources of F^- , the fluoride anion. The challenge of using nucleophilic fluorine arises from the high basicity and the hydrogen bonding properties of the fluoride anion. Its nucleophilicity can also be dramatically decreased by its ability to form stable solvation shells. There are many commercially available sources which can be used, including alkali metal fluorides, such as cesium fluoride, CsF, and potassium fluoride, KF. As the ionic bond strength of the compound increases, the nucleophilicity of the fluoride is decreased, making lithium fluoride the least reactive of the alkali metal fluorides. Tetraalkylammonium fluoride salts, such as tetrabutylammonium fluoride (TBAF, **76**) is a good commercial source of nucleophilic

fluorine (Figure 5.4). Using a tetraalkylammonium counterion for the fluoride will decrease the ionic bond strength making them good reagents for nucleophilic fluorination. Sulfur fluorides, such as (diethylamino)sulfur trifluoride (DAST, **77**) which is a less toxic and less volatile version of sulfur tetrafluoride, is used for the conversion of alcohols to alkylfluorides (Scheme 5.4), are also good commercial sources of nucleophilic fluorine (Figure 5.4). while ^{4,17}

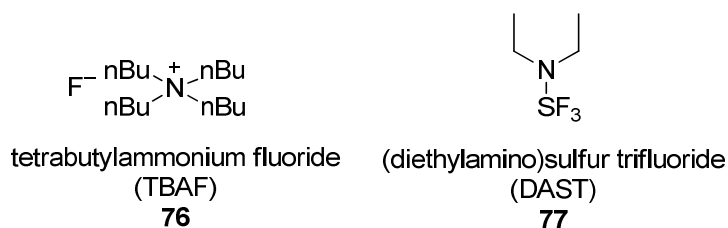
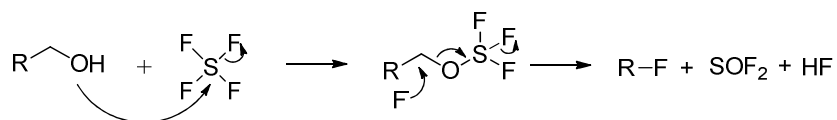
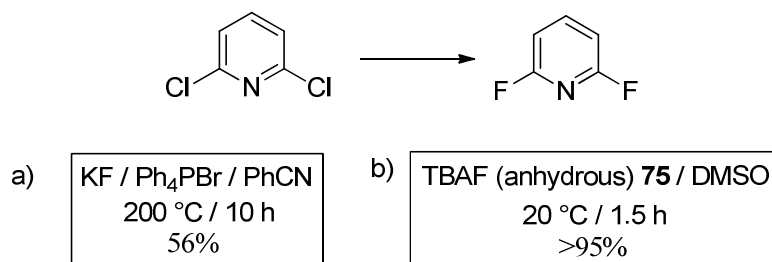

Figure 5.4: Nucleophilic fluorinating reagents



Scheme 5.4: Alcohol conversion to alkyl fluoride using nucleophilic fluorine

TBAF **76** has been found to be extremely useful in halogen exchange and fluorodenitration reactions. In the halogen exchange reactions the leaving group is a halogen atom, and the nucleophilic fluoride source is usually a cheap inorganic salt such as KF. For this reaction to occur with good yields, high temperatures, long reaction times and a phase transfer catalyst are needed. However when the fluoride source is TBAF the reaction time and temperature can both be reduced dramatically. TBAF is also soluble in many organic solvents, leading to more efficient reactions and increased yields (Scheme 5.5).^{4,17}



Scheme 5.5: A typical halide exchange reaction a) versus b) (TBAF **75** as the fluoride source B).

Fluorine as an electrophile, F^+ , is less easy to achieve than fluorine as a nucleophile, mainly because it is the most electronegative element, however compounds have specifically been made in order for this to be possible. They are compounds which can withdraw electronic charge from fluorine by inductive effects, or that have excellent leaving groups adjacent to the fluorine atom. There are three main classes of electrophilic fluorinating reagents (Figure 5.5). The first of which are *N*-fluoropyridinium salts **78**, prepared by the addition of molecular fluorine to pyridine in the presence of chlorotrifluoromethane (CF_3Cl). The reactivity of this class of compounds can be altered with the addition of substituents to the pyridine ring, allowing them to react with many different nucleophiles. The counterion also provides a way of changing the physical properties of the salts, for example when **78** has a triflate counterion it is stable at room temperature and is soluble in many organic solvents. However when the counterion is a perchlorate, the compound is both shock and temperature sensitive.^{4,17,18,19}

The second class of compounds is that of the *N*-fluorosulfonamides. They are easily prepared by the reaction of *N*-alkylsulfonamides with diluted elemental fluorine. One of the more popular sulfonimide derivatives is **79**, *N*-fluorobenzenesulfonimide (NFSI), developed in 1991 and now commercially available, showing reactivities for fluorination between the more powerful *N*-fluoro-trifluoromethylsulfonimide, which is not commercially available, and the less powerful alkylsulfonamides.^{4,9,17}

The most powerful of the electrophilic fluorinating reagents is Selectfluor **80** developed by Banks *et al.* This was a big step forward for electrophilic fluorinations because it is commercially available, reliable, stable and allows large scale reactions. One of the major advantages of this compound compared to others is its stability, whereas many electrophilic fluorinating compounds have to be treated extremely carefully because of shock or heat limitations, **80** has been shown to be stable up to 195 °C. The preparation of this compound was designed to be relatively simple so it could be made on industrial scale quantities, and so that different analogues could be made (Scheme 5.6). The precursor for the synthesis is triethylenediamine (DABCO), which is treated with dichloromethane, followed by a counterion exchange and fluorination with F₂.^{9,17,20}

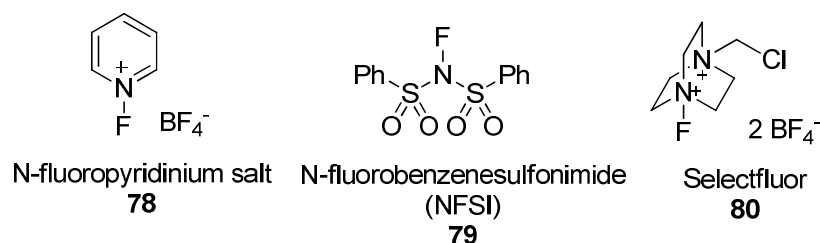
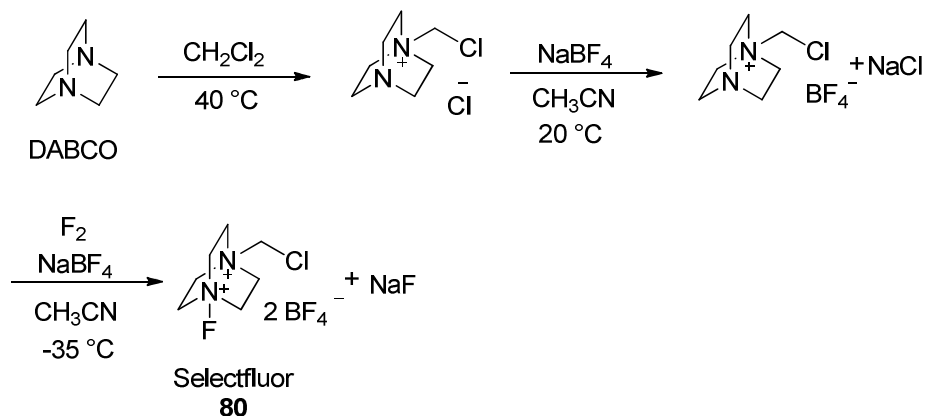

Figure 5.5: Electrophilic fluorinating reagents

Scheme 5.6: Reaction scheme for the preparation of Selectfluor **80**

5.2.2 Electrochemical Fluorination

The two main ways for the addition of fluorine to a molecule mentioned above were the direct formation of the C-F bond already discussed or the “building block” method. However there is a third method for fluorination reactions, the electrochemical method, which is also capable of both direct and “building block” approaches to fluorination reactions, the latter being discussed in the results and discussion section of this chapter as the main subject of interest.

The first electrochemical process involving fluorinations was developed by Simons *et al.*²¹ for the perfluorinations of a wide range of organic compounds from electrolysis in liquid hydrogen fluoride at nickel anodes. It has been used for more than 60 years and has become a very versatile method of perfluorination. The major drawback of this synthesis is the use of liquid HF as both the solvent and as the fluorine source which is a very corrosive substance, and other dangerous substances are produced as side products during the electrosynthesis.

However, the first major breakthrough in the area of partial electrochemical fluorination came in the 1970's with the introduction of triethylamine-HF dissolved in acetonitrile as the electrolysis medium. This is a much safer route to the fluorine source and led to other HF salts being prepared such as, $\text{Et}_4\text{NF}\cdot n\text{HF}$ dissolved in acetonitrile, as well as pyridine-HF (Olah reagent) which was reported as a stable and inexpensive reagent and found to be effective for fluorination reactions. Electrochemical fluorinations have advantages over many of the current synthetic methods. The compounds used for fluorinations are not toxic and mild conditions can be used for electrochemistry. The method has the advantage of being able to control the process with the applied current, and some of the salts, such as $\text{Et}_3\text{NF}\cdot n\text{HF}$, can be easily recycled by distillation. Addition of fluorine using these salts has been successfully used for a huge range of organic substrates such as, olefins, aromatics, ethers, heterocycles and aryl sulfides.²²⁻²⁵

The two examples shown are fluorinations of olefins. The electrolytic oxidation of unsaturated C=C double bonds is expected to proceed through a 1,2- addition to give the corresponding *vicinal* difluorinated products (Scheme 5.7). One example is the reaction

of styrene (**81**), which yields the 1,2 addition product in yields of up to 60% (Scheme 5.8). However when a large or an aromatic substituent is attached to the double bond, for example stilbene (**82**), the cationic intermediate is stabilised and a competing reaction to the second fluorination such as, acetamidation can occur. The acetonitrile in the solvent system acts as a nucleophile and can attack the carbocation intermediate which is the predominant product in this reaction although some of the bis-fluorinated product is found also. However, by changing the solvent system to dichloromethane for example, the acetamidation is impossible (Scheme 5.9).^{22–25}

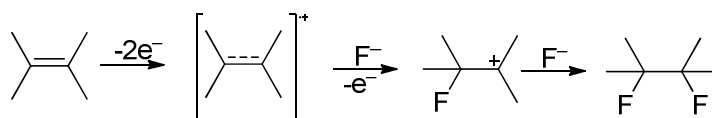

Scheme 5.7: General reaction mechanism for the fluorination of alkenes

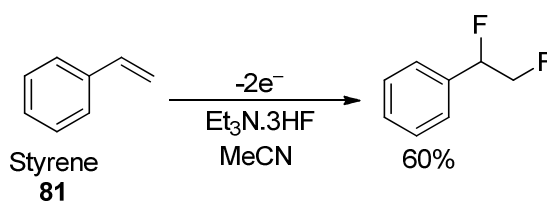

Scheme 5.8: Electrofluorination of styrene

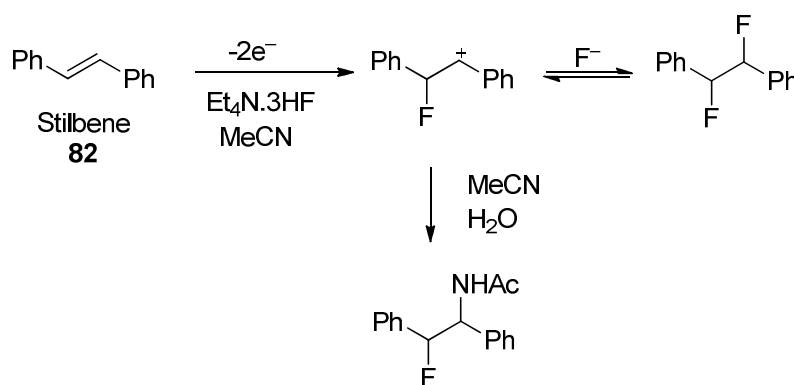
Scheme 5.9: Electrochemical fluoroacetamidation of stilbene²³

5.2.3 The “Building block” method

The “building block” method is the use of compounds that already contain a carbon fluorine bond to incorporate the fluorine moiety into another molecule. Simple sources of these include trifluoroacetonitrile, and trifluoroacetic acid. Trifluoromethylation is a direct approach to fluorine containing molecules and many methods and reagents have been developed for this purpose.

Radical trifluoromethylation reactions were reported in the 1940’s by Haszeldine *et al.*²⁶ In the reactions CF_3 radicals are generated from iodotrifluoromethane **83** through C-I bond homolysis, initiated purely by a thermal reaction or irradiation. In the presence of ethene the reaction yielded 3-iodo-1,1,1-trifluoropropane from a radical addition/iodine transfer reaction (Scheme 5.10).²⁷

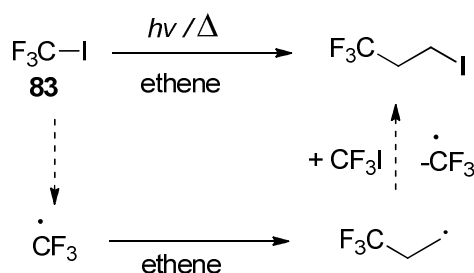

Scheme 5.10: Radical formation and reaction of trifluoromethyl iodide²⁷

The most versatile and widely studied area of trifluoromethylation reactions is the nucleophilic approach. The first reagent of which was reported in 1984 by Ruppert *et al.*²⁸ Ruppert’s reagent **84**, is formed by the condensation reaction between CF_3Br and Me_3SiCl . The synthesis has since been improved to give higher yields, use lower temperatures and use fewer equivalents of the CF_3 radical source. Ruppert’s reagent has been proven to be a versatile trifluoromethylating agent on a variety of different substrates. One of the factors that make it such an effective nucleophilic trifluoromethylating reagent is to do with the weak Si- CF_3 bond. The electronegativity of fluorine makes the carbon atom positively charged which repels the silicon centre.^{9,29}

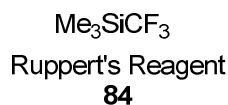

Figure 5.6: Ruppert's reagent

Electrophilic trifluoromethylation has also been widely studied despite the unfavoured formation of the positive CF_3 cation. The first to develop such a reagent were Yagupolskii *et al.*³⁰ in 1984, they developed *S*-(trifluoromethyl)diarylsulfonium salts **85** (Figure 5.6) which were good electrophilic trifluoromethylating agents but were limited to thiophenolates. This led to the development of such reagents that could be used on a wide variety of substrates by varying the electrophilicity of the reagent.⁹

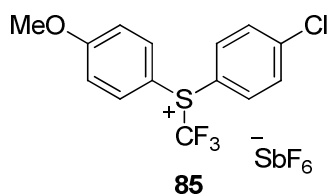
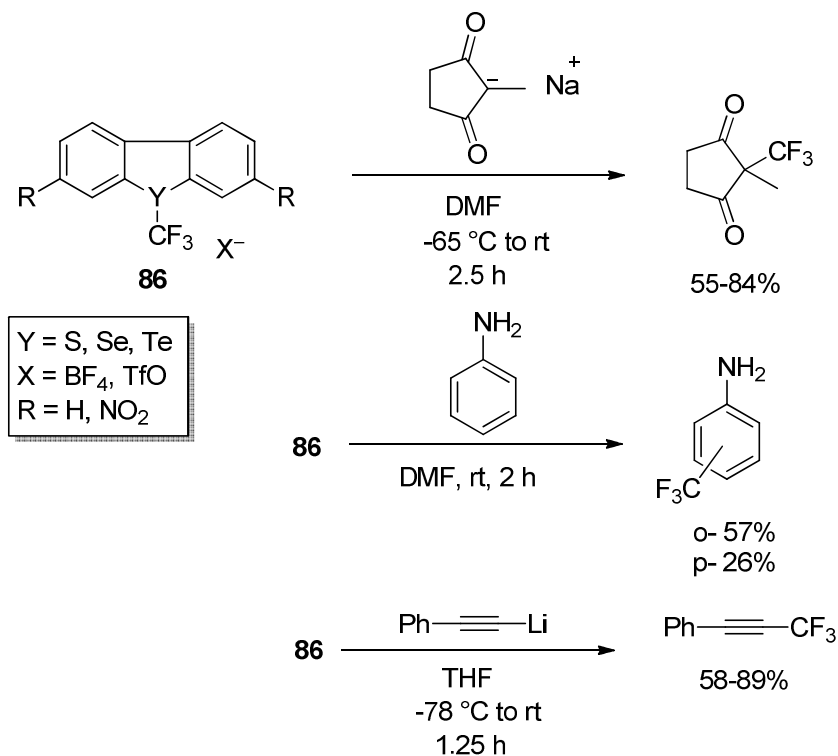

Figure 5.7: The first electrophilic trifluoromethylating agent

It was Unemoto *et al.*³⁰ that were able to do this with (trifluoromethyl)dibenzo-heterocyclic salts of type **86** (Scheme 5.11). The reactivity of these compounds can be altered by changing the heteroatom, the aryl substituents and the counterion making them very appealing reagents. They are prepared in either a two-step oxidation of the starting sulfides or selenides followed by the cyclisation of the resulting sulfoxides or selenides. The other method is the direct fluorination of the sulfide or selenide with N_2/F_2 with one equivalent of triflic acid or HBF_4 providing the counterions. The wide range of trifluoromethylated substrates includes enolates, electron rich aromatics and thiolates. To increase the electrophilicity of their original salts with substituents on the benzene ring, they made the corresponding nitro-substituted salts and a selection of reactions with these reagents is shown below (Scheme 5.11).



Scheme 5.11: Electrophilic trifluoromethylations using Unemoto reagents

5.2.4 Fluorinations using microreactors

As described earlier in the general introduction, microreactors have become important tools in synthetic chemistry, making existing routes more accessible with safer handling of dangerous chemicals due to low concentrations. The area of fluorine chemistry is no different and has found practical uses for microreactor technology.

One example is the conversion of alcohols and carbonyl groups to the corresponding fluorinated products using DAST (**77**) as the fluorinating agent reported by Seeberger *et al.*³¹ By using the microflow system shown in Figure 5.8 the authors were able to produce the fluorinated products in excellent yields and in most cases no further purification was required. The residence time was 16 minutes at room temperature which for the example shown below (Scheme 5.12) is roughly half the reaction time for the same reaction in a typical batch fluorination.^{32,33} The yield is also a huge improvement on the batch example where 4.5 g of product was isolated per reaction,

with also the benefits of no purification and the ability for the simple scale up procedures possible for flow systems.³¹

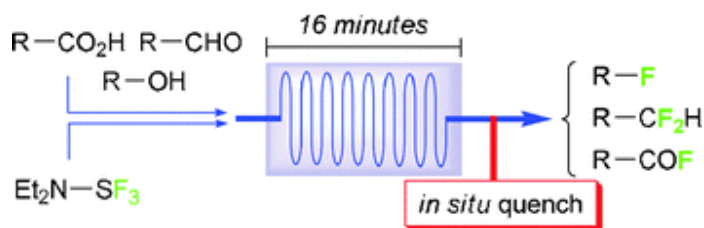
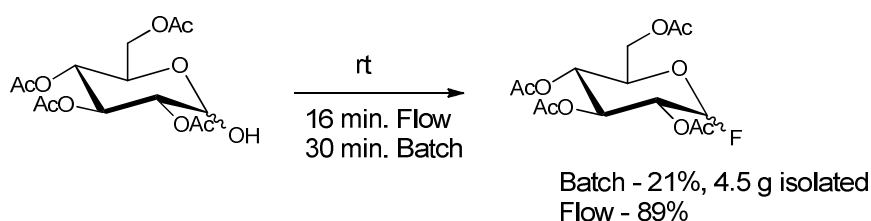
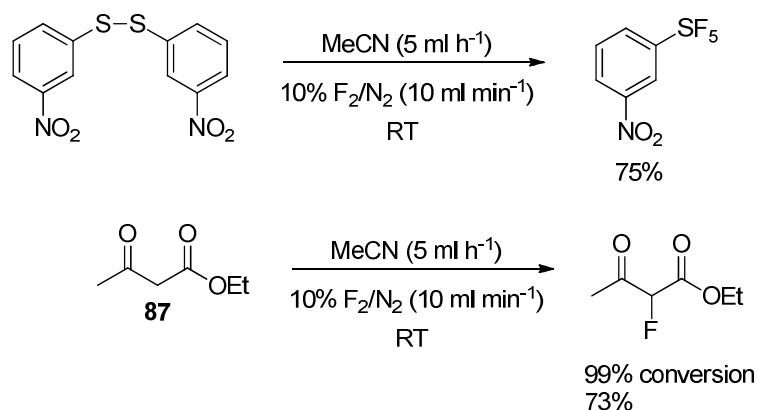

Figure 5.8: The microflow system used for fluorination³¹



Scheme 5.12: Flow vs. Batch comparison³¹

Elemental fluorine has also been utilised in a number of microreactor systems to achieve direct fluorinations. One example of this is reported by Chambers *et al.*³⁴ where they describe the fluorination of sulfur-containing compounds and also of β -dicarbonyl compounds in good yields, and in the case of ethyl acetoacetate **87** an almost quantitative conversion of the starting material. Their microreactor was a nickel block with a channel cut out of the middle for the reaction to flow through, the top section was a transparent block of polychlorotrifluoroethylene, reported to have a catalytic effect on the reactions due to the fluorine present, while also allowing the authors to view the reaction. A third of the way down the channel was an inlet where 10% F_2/N_2 was introduced into the reaction mixture, and the products simply flowed out of the outlet to be collected. The authors report that the reaction through the channel proceeded via a cylindrical flow, which is the outer layer being the reaction solution while the gas flows through the centre. The reactor allows good mixing because of surface to volume ratios of the gas to liquid phases. Cooling is also helped by cooling channels running through the base of the block. Two examples are shown below (Scheme 5.15).



Scheme 5.13: Examples of using elemental fluorine in flow

The same group were also able to take this work further than creating fluorinated diketones, they developed a microflow gas/liquid – liquid/liquid flow system to cyclise the fluorinated diketones to fluoropyrazoles in high yields. This was done by simply adding a T-piece connector to the already existing microreactor set-up and introducing hydrazine derivatives into the system as shown below (Scheme 5.14). The nickel block reactor described above was used for the fluorination during the gas/liquid stage of the reaction while a tubing coil was used for the second stage. Using different solvents depending on the solubility of the hydrazine derivative was necessary, but by choosing one that was miscible with the acetonitrile from the first step was crucial to the liquid/liquid stage of the reaction. The synthesis of a variety of fluoropyrazoles was demonstrated in good yields, with the ability to functionalise the product from both the starting diketone and the hydrazine derivatives. This is a good example of how simply microreactor systems can be made to run sequential reactions with no work up in between although the authors report that the final products were purified by column chromatography.³⁵

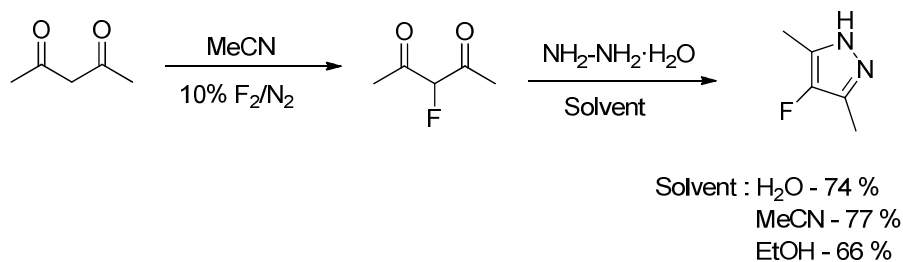

Scheme 5.14: A sequential microreactor set-up for the production of fluoropyrazoles

5.3. Results and discussion

Trifluoroacetic acid, one of the most readily available, cheapest and relatively safe forms for a trifluoromethyl building block, seemed a very interesting prospect for our flow reactor being a “green” source of the trifluoromethyl group. The trifluoromethyl radical is formed by the Kolbe decarboxylation of trifluoroacetic acid to give the radical intermediate **88** (scheme 5.15), which can then react with different substrates (Scheme 5.16).

After construction of the electrochemical microreactor (see chapter 2) some of the test reactions carried out were the Kolbe coupling of carboxylic acids described earlier (Chapter 2). The results achieved showed that it would be possible to form the trifluoromethyl radical in the flow reactor and achieve the desired trifluoromethylated products. The reported methods of trifluoromethylation use platinum electrodes,³⁶ like our device so work began in this area to try and create a general set of reaction conditions for trifluoromethylations in a flow cell.

Renaud *et al.*³⁷ reported in the late 1970’s the synthesis of trifluoroethane. The second paper in the series³⁸ starts with the intention of optimising this reaction but during one run of the experiments, none of the expected products were found. Instead compounds containing trifluoromethyl groups were identified. These were attributed to the reaction of the CF₃ radicals with the adsorbed ethylene radical formed during the reaction. The group continued work in this area doing reactions with different substrates, malonic esters, unsaturated carboxylic esters,³⁹ and also with mono- and disubstituted olefins.⁴⁰ It was in this paper, the fourth in the series, that the authors attributed the formation of

either the mono- or dimeric products to the concentration of the substrate. This work highlighted that trifluoroacetic acid could be used for radical trifluoromethylations under electrochemical conditions.

This work was then investigated by Uneyama *et al.*, and a short review was published,³⁶ showing the five possibilities for different types of reactions that can be achieved by the trifluoromethylation of suitable substrates (Scheme 5.16). This work was taken in order to design a general set of reactions to synthesise different trifluoromethylated building blocks in an electrochemical microreactor.

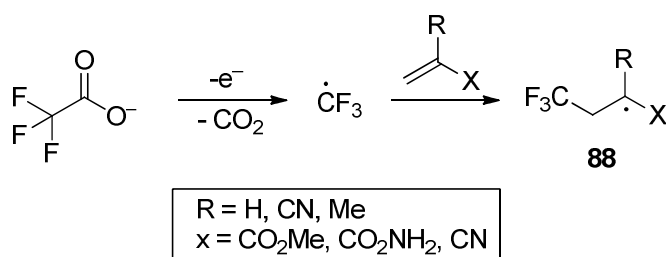

Scheme 5.15: Formation of CF₃ radicals and radical formation after attack on olefins

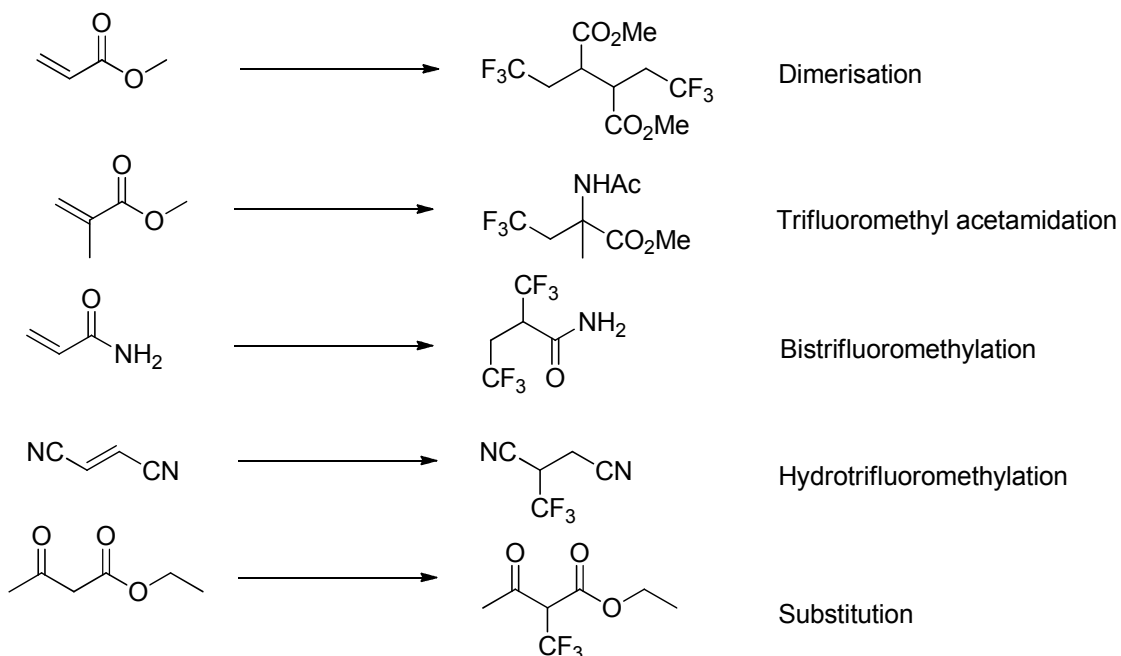

Scheme 5.16: Possible trifluoromethylation reactions with different substrates

5.3.1 Bistrifluoromethylation

Uneyama *et al.* published two papers describing the trifluoromethylation of acrylamide (Scheme 5.19), the first being in a batch cell and the second in a flow cell.^{41,42} The reaction begins by the oxidation of trifluoroacetic acid to give the CF_3 radical which attacks the $\text{C}=\text{C}$ double bond to give the radical **88**. This then reacts with another CF_3 radical to give the bistrifluoromethylated product of **90**.

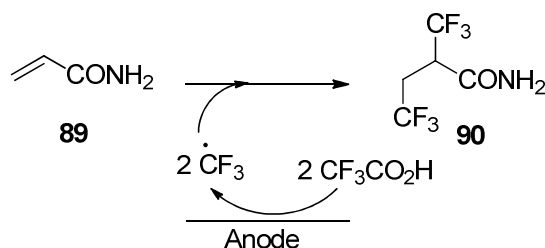

Scheme 5.17: Electrochemical bistrifluoromethylation

This was the starting point for our research into trifluoromethylations in flow as this reaction had already been proven successful in a flow environment. The conditions reported could not simply be applied to initial reactions as the paper was vague with regards to the cell volume and no residence times were reported. The flow cell described by them had a much greater electrode area (3 x 3.3 cm) and flow rates of up to 0.5 L min^{-1} could be used.

Preliminary experiments undertaken to start this work revolved around running the reactor with a variety of settings for current and flow rates monitored by TLC and NMR. NMR experiments were undertaken by running small scale reactions (typically 3-4 ml). The work-up is then carried out using a deuterated solvent. An accurate estimation of conversion of the starting material to **90** by NMR was difficult because of side products formed during electrolysis.

Once an acceptable set of conditions is found, the reactions are run on a larger scale, typically a 10 ml solution, this could then be worked-up and subjected to column chromatography to isolate the product.

The flow example by Uneyama *et al.*⁴² showed a reasonable yield using a current density of 100 mA cm^{-2} . Whereas in the batch example a higher current density (200 mA cm^{-2}), was said to bind the amide moiety of the substrate tightly to the electrode so the second CF_3 radical has the opportunity to react with the intermediate radical **88** rather than the substrate dimerising.

First reactions were started at the reported current density of 100 mA cm^{-2} with a substrate concentration of 0.1 M , 0.4 M TFA and 0.04 M NEt_3 ($10 \text{ mol}\%$ with respect to TFA). The literature reaction conditions used NaOH as the base, but it was known that having an inorganic base in our device would cause problems, blackening of the electrode surface was observed and they needed to be polished. This led us to revert back to conditions described with the Kolbe test reactions (Chapter 2), using triethylamine. The experiments to obtain NMR data showed that the product was being formed in our flow device. There were also a number of side products and some remaining starting material.

At 100 mA cm^{-2} a full conversion of **89** was not achieved at concentrations of 0.1 M . It was visible in the NMR spectra at any flow rates between 0.05 ml min^{-1} (26.4 second residence time) and 0.12 ml min^{-1} (11 second residence time). However with the longest residence time of 26.4 seconds the NMR conversion looked to be at its highest and a 10 ml solution was run at this stage to obtain an isolated yield. It was encouraging that a 40% (Entry 1, Table 5.1) yield of **90** was achieved at 100 mA cm^{-2} with an incomplete conversion of starting material, already an improvement on the reported batch example, 35% .⁴¹

The current was then raised to equal that of the batch example, 200 mA cm^{-2} . Now a full conversion of the starting material could be achieved, but in all reactions there were two visible side products in the NMR spectrum. The two side products, **91** and **93** (Scheme 5.18) were difficult to separate via column chromatography. However, from the NMR of the fraction containing both compounds it appeared that the mono-trifluoromethylated (*cis* and *trans*) acrylamide **91** was formed from radical **88** undergoing a second

oxidation step and loss of a proton, and the dimerised product **93**, from the dimerisation of the radical **88**. These products were also identified by Uneyama *et al.*⁴²

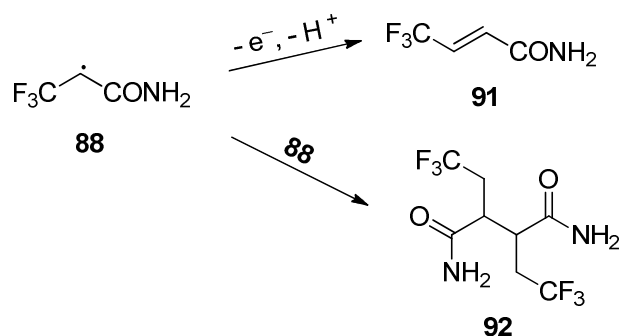

Scheme 5.18: Side products of the bistrifluoromethylation reaction

When equivalent reactions were conducted at 100 and 200 mA cm⁻² (Entries 1 and 2, Table 5.4), the result was unexpected as a full conversion of the starting material was achieved. This led us to believe it was the long reaction time increasing the amount of side products formed. When the flow rate was increased, 100 μl min⁻¹ at 200 mA cm⁻², the yield increased to 42% (Table 5.4 entry 3). This was comparable to the yield obtained by Uneyama in flow (48%). This seemed to be the best compromise between the conversion of starting material, which could not be achieved at 100 mA cm⁻², and flow rates, with slower flow rates causing greater amounts of side products.

Entry	I (mA cm ⁻²)	Res. T (s)	Eq. TFA	Yield 90 (%)
1	100	26.4	4	40
2	200	26.4	4	30
3	200	13.2	4	42
4	200	13.2	8	48
5	200	13.2	16	66
6	200	13.2	32	68
7	200	11	16	45
8	200	16.5	16	53

Table 5.4: Isolated yields of **90**

The effect of the ratio of TFA to starting material was then investigated. As the desired product is the result of bistrifluoromethylation of **89** the ratio of TFA to acrylamide was increased. An increase in CF_3 radicals should increase the likelihood of initial trifluoromethylation of **89**, in turn creating a higher concentration of the radical **88** in the reaction solution. The nitrogen atom of the intermediate **88** reported by Uneyama *et al.*³⁶ to adsorb to the platinum electrode surface by the high current density, is also more likely to undergo the second attack of CF_3 radicals to give **90**. The ratio of TFA to the substrate **89** described in the literature was 4:1 in both batch and flow examples. However in a batch reaction the radicals being produced have a much longer reaction time, because it is not determined by the residence time in the flow cell, increasing the chance to react with the starting material until the theoretical amount of current was passed. In this case it was 2.5 hours. Unlike in flow where the residence time in most cases is less than 1 minute before the reaction is over. The effect of increasing the ratio of TFA did increase the yield as expected and yields of **90** of 66% at 16:1 and 68% at 32:1 were achieved (Entries 5 and 6, Table 5.4)

The last experiments run for the optimisation were kept at a TFA ratio of 16:1 as the benefits of increasing the number of equivalents of TFA were minimal. Reactions with residence times just above and below that of the best result obtained 66% (Entry 5, Table 5.4) were carried out, but both turned out to be unsuccessful at increasing the yield (Entries 7 and 8, Table 5.4).

The outcome of the first trifluoromethylation in the flow cell was encouraging, having improved reported yields for both batch and flow that had been previously reported under the conditions in Scheme 5.19,^{41,42} but it seems that because of the formation of the side products under all reaction conditions, that further optimisation would not lead to a quantitative conversion to **90**.

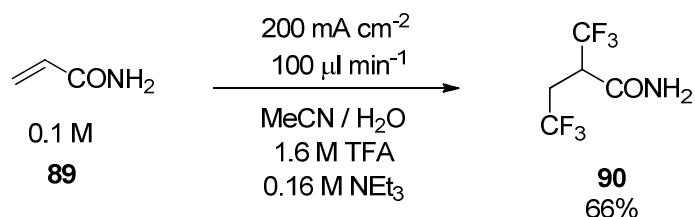
Scheme 5.19: The optimum conditions for the conversion of **89** to **90**

Attempts were made in order to change the reaction conditions so a sequential Hofmann rearrangement could be investigated directly after the synthesis of **90**. The main problem was the fact that the solvent system to produce **90** is acetonitrile and water in a ratio of 7:1. Water, where present in the Hofmann rearrangement, would cause the formation of the corresponding amine *via* decarboxylation and lead to a mixture of products being formed.

5.3.2 Dimerisation

The second reaction in the set of trifluoromethylation reactions was the trifluoromethyl induced dimerisation of methyl acrylate to give **93a** and **93b** (meso and dl isomer) (Scheme 5.20), described by Uneyama *et al.*,⁴³ Renaud *et al.*^{39,40} and Pedler *et al.*⁴⁴ Literature examples were carried out with 3 or 4 equivalents of TFA or with the example reported by Uneyama *et al.*, less than one equivalent TFA was used to simplify the work-up procedure for a large scale reaction.

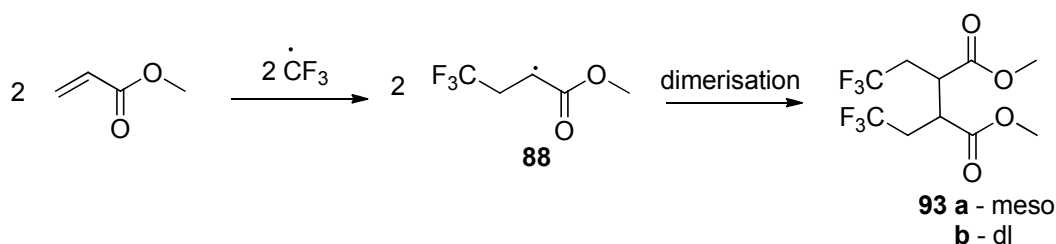
Scheme 5.20: Dimerisation of **89**

The trifluoromethyl radical induced dimerisation of methyl acrylate was investigated. Initial experiments (Entries 1 and 2, Table 5.5) were conducted using 0.1 M methyl acrylate, 0.4 M TFA, 0.04 M NEt₃, a flow rate of 100 μl min⁻¹, and a current density of

80 mA cm⁻², described by Uneyama *et al.* to give the highest yield for the product in a batch cell, 50%.⁴³ Under these conditions the highest yield of **93** obtained was 33%. When the residence time was increased from 13.2 to 26.4 seconds a dramatic decrease in yield was observed and only 6% of **93** was isolated. It was thought to be due to the product being over oxidised with a prolonged reaction time

The concentration of TFA was then increased to 16 equivalents to try and improve yields. It was thought by increasing the concentration of TFA the concentration of **88** would also be in a higher concentration as the initial attack of CF₃ radicals on the substrate would be more likely, and with higher concentrations of **88** the chance of dimerisation of **88** should be higher. The lower current density used in the reaction was said to not bind the substrate to the electrode surface tightly, as seen in the bistrifluoromethylation reaction, and the intermediate radical **88** would be able to diffuse away from the electrode surface to allow dimerisation. This increase in TFA gave us a maximum yield of 42% of **93** (Table 5.5 entry 3).

Entry	I (mA cm ⁻²)	Residence Time (s)	Eq. TFA	% meso 93a	% dl 93b	Ratio (meso : dl)	Yield 93 (%)
1	80	13.2	4	48	52	1:1	33
2	80	26.4	4	54	46	1:1	6
3	80	13.2	16	52	48	1:1	42
4	100	13.2	16	69	31	2:1	24
5	60	13.2	16	81	19	4:1	7

Percentage of meso and dl isomer calculated from ¹H NMR

Table 5.5: Isolated yields of **93**

The ratio of isomers for the best result (Entry 3, Table 5.5), is almost identical to that achieved by Uneyama *et al.*,⁴³ 1:1. During some of the reaction conditions (Table 5.5), it was possible to increase the percentage of the meso isomer, quite dramatically in the case of entry 5, however the yield was much lower. There seemed to be no pattern to the increase of this isomer. In the case of entries 4 and 5, the flow rate was kept the same as the optimal conditions (Entry 1, table 5.5), but the current density was varied. Both

increase the percentage of the meso isomer but lowered the yields, with the lower current density most likely not being high enough to completely oxidise the TFA. If the intermediate radical **88** (Scheme 5.20), was bound tighter to the electrode with the higher current density, then it would be less likely to diffuse away from the electrode to dimerise with another radical.

The increase in yield with an increase of TFA can be explained because when there are fewer CF_3 radicals present in the reaction solution, there is obviously a lower percentage of intermediate **88** able to undergo a chemical reaction to give the desired dimer.

The effect of concentration was also investigated, it was thought that increasing the concentration of the substrate would increase the concentration of intermediate **88** present in the cell and encourage dimerisation. This was not the case as can be seen from Table 5.6, showing that it is most likely the case that the low yields obtained are from unreacted starting material.

Another effect examined was the distance between the electrodes, because the substrate was not needed to be bound tightly to the electrode as in the previous example, the cell volume was doubled, by increasing the thickness of the FEP channel, hoping that it would allow more of the intermediate **88** to diffuse away from the electrode where it could dimerise. This also led to a much lower yield. The larger distance between the electrodes shouldn't have interfered with the current flow through the system because of the TFA in the reaction, again leading to the possibility that the starting material was not reacting efficiently with the CF_3 radical. The substrate could also have been reacting directly with the electrode before the CF_3 radical was generated. This is more likely to occur in a flow system than a batch cell because of the close proximity of the electrodes, and constant contact of the substrate with the electrode during the reaction.

Entry	I (mA cm ⁻²)	Residence Time (s)	Eq. TFA	Concentration (M)	Cell volume (ml)	Yield 93 (%)
1	80	13.2	16	0.2	0.022	35
2	80	13.2	16	0.3	0.022	25
3	80	26.4	16	0.2	0.045	13
4	80	13.2	16	0.2	0.045	5

Table 5.6: The effect of concentration and electrode distance for **93**

As with the bistrifluoromethylation reaction the reported batch reaction time was 16 hours, in this case to yield 81g, a great difference to a 13 second residence time. With the optimum yield of 47% (Entry 1, Table 5.7) the reactor was producing 140 mg of **93** per 96 minute reaction. However, our microflow system could be run continuously, with an elongated reaction channel, or with multiple reactors in parallel if a large scale reaction was needed to achieve an equivalent scale reaction without the need to optimise reaction conditions.

Uneyama *et al.*⁴³ reported the use of compound **93** in a number of reactions to show the use of trifluoromethylated building blocks, using an excess of substrate rather than TFA. This was to simplify the work up procedure to make it more appealing for large scale synthesis. So these conditions were attempted in flow for the same reason, but with a possibility of a direct sequential reaction.

Three reactions were conducted using a slight excess of methyl acrylate, 0.09 M TFA was used (Scheme 5.21). The results can be seen in Table 5.7.

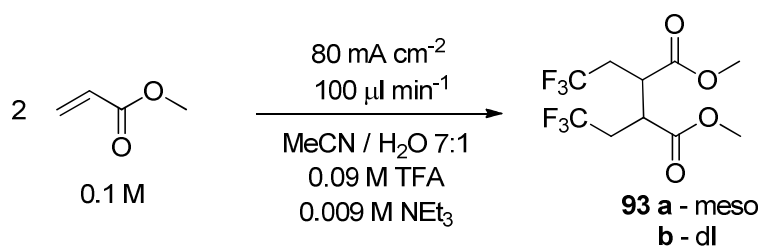

Scheme 5.21: Reaction conditions using an excess of methyl acrylate

Entry	I (mA cm ⁻²)	Res. T (s)	Yield 93 %
1	80	16.5	47
2	80	13.2	38
3	80	22	45

Table 5.7: Isolated yields of **93** with an excess of substrate

The results show a slight improvement on yields that were achieved when using an excess of TFA, meaning that the formation of side products was less likely, however varying the flow rate, one of the factors controlling mass transport, made very little difference in yield, showing that the formation of side products was the cause for the yield remaining lower than 50%. Only when the residence time was decreased to 13.2 seconds (Entry 2, Table 5.7) was there a decrease in yield, unlike in table 5.5, entry 3 where with an excess in TFA a higher yield was obtained, which shows the residence time and concentration of TFA affect the outcome of the reaction, with a longer residence time needed with less TFA

Once again, when attempts were made to remove the water from the solvent system, blocking of the channel was observed and electrolysis was terminated. This meant that a sequential reaction would not work.

5.3.3 Hydrotrifluoromethylation

This reaction was thought to be the most challenging in the series for us to complete for two reasons. The first is because it was uncertain as to whether the device could be efficiently heated to carry out the reactions at the temperatures reported by Uneyama *et al.*⁴⁵ (50° C). The reaction was said to be temperature dependent for the formation of the succinonitrile radical **95** (Scheme 5.22).

The second factor that was thought could be problematic using a flow device, was that because during the reaction the radicals that are being formed are on opposite electrodes, CF₃ at the anode, and **95** at the cathode. This would limit the chance for a reaction between the two unless both radicals were able to diffuse to the bulk solution efficiently.

If this was the case, it is possible that only the reduced substrate or dimer would be formed.

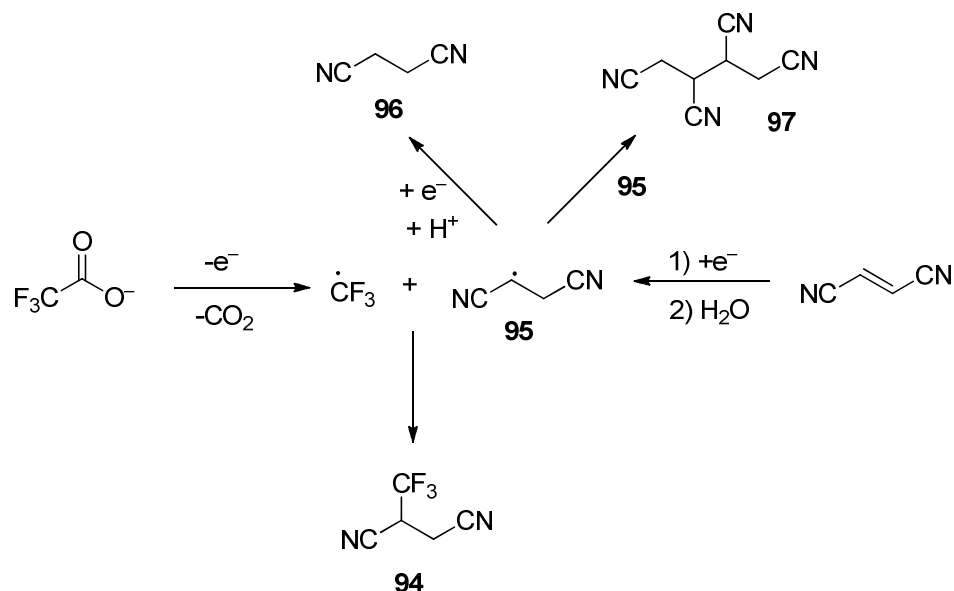

Scheme 5.22: Hydrotrifluoromethylation of fumaronitrile

The reaction was studied in detail by the Uneyama *et al.*⁴⁵ and when tested in a divided cell, no reaction between the CF_3 radical and substrate took place, accredited to the extremely electron deficient double bond being unreactive towards the CF_3 radical. When the reaction took place at low temperatures, the intermediate radicals **95** were said to be tightly bound to the electrode and diffuse less into the bulk of the solution, creating either succinonitrile **96** or the dimer **97** (Scheme 5.23) confirming the existence of the intermediate, but elevated temperatures were found to be needed to get the desired products.

In contrast, work carried out by Uneyama *et al.*⁴⁵ on the oxidation of TFA at varied temperatures show an almost quantitative conversion of TFA at 0 °C, decreasing with an increase in temperature to be roughly 50% at 50 °C. Even so at 50 °C the authors achieved an optimal yield of 65% of **94**, a compromise between the formation of the two radicals.

Before initial reactions were undertaken a way of incorporating the microreactor device into a gas chromatography oven had to be devised. The inlet tube for the reaction solution and the electric cables were fed through the holes in the side of the oven and the microreactor was held on a clamp inside. The device was allowed time to warm up to 50 °C and the reaction was started. No back pressure regulator was necessary as the temperature was below that of the boiling point for the solvent system, and the collection vial was sealed, and covered so the solvent could not evaporate as the reaction was being run,

Initial reactions were conducted with a substrate concentration of 0.1 M, 0.4 M TFA, 0.04 M NET_3 , with flow rates and current densities varied.

From NMR spectra obtained from small scale reactions at varied flow rates at currents of 60 and 100 mA cm^{-2} at 50 °C, it was observed that the major peaks in the NMR spectra were for the starting material and succinonitrile **96** (the reduced form of **95**), (4H, s, 2.67ppm) (Table 5.8). The crude NMR showed possible formation of **94** but the reaction was so inefficient with respects to starting material conversion and formation of succinonitrile **96** that reactions in the oven were stopped. It was obvious that the intermediate **95** was being formed at the cathode because it was able to dimerise to form **96**, but due to the higher temperature lowering the efficiency for the formation of CF_3 radicals, formation of **94** was minimal. This shows that the higher temperature reducing the efficiency of CF_3 radical is causing the low conversion of the substrate.

Entry	Residence time (s)	I (mA cm^{-2})	% SM	% Succinonitrile 96
1	13.2	60	86	14
2	16.5	60	97	3
3	13.2	100	77	23
4	16.5	100	20	80

Table 5.8: Calculated conversion from ^1H NMR spectra at 50 °C

The previous bistrifluoromethylation and dimerisation reactions in this chapter had been carried out successfully at room temperature when literature examples for batch reactions were carried out at 0 °C to maximise the formation TFA. Uneyama *et al.*⁴⁵ also

report formation of the **94** at room temperature, although much lower yielding and a mixture of the three products, **94**, succinonitrile and the dimer of **95** being formed so room temperature reactions were carried out.

At room temperature, again small scale reactions were carried out to reveal whether the desired products could be formed and a better conversion of starting material could be achieved. The NMR spectra for these experiments were somewhat encouraging.

At residence times of 16.5 and 22 seconds full conversion of starting material was achieved, however, almost quantitative conversion to succinonitrile was seen, with very small amounts of side products visible with a current density of 100 mA cm^{-2} . The formation of succinonitrile at higher current densities suggests that the intermediate **95**, is bound tighter to the electrode surface and undergoes a second reduction step to form **96** (Scheme 5.22).

When reduced to 60 mA cm^{-2} at a residence time of 16.5 seconds, a ratio of 23:77 in favour of succinonitrile was once again seen. However when slowing the reaction to a residence time of 22 seconds (Scheme 5.23) there was a change of products seen in the NMR spectra. There was no complete conversion of starting material, but in addition to succinonitrile, there was clearly a doublet at 3.25 ppm with a multiplet at 3.99 ppm integrating correctly indicating the formation of **94**, and two multiplets at 3.13 and 3.87 ppm corresponding to the formation of the dimer **97**.

From this, it would seem that if the ratio of TFA to substrate was increased, that it would encourage the formation of **94**, and suppress the formation of succinonitrile at room temperature. To confirm traces of the desired product had been formed, the reaction solutions used to obtain NMR data were combined and subjected to column chromatography so compounds **94**, **96**, and **97** could be characterised.

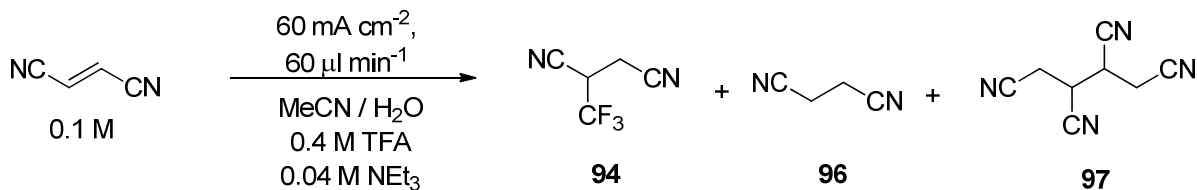

Scheme 5.23: Conditions for hydrotrifluoromethylation

5.3.4 Substitution

In the series of trifluoromethylation reactions the substitution of the CF_3 group onto active methylene compounds was the next to be investigated (Scheme 5.24). This reaction was possibly the most suited to a sequential reaction in flow. Sandford *et al.*³⁵ (Scheme 5.16) have shown that it is possible to synthesise fluoropyrazoles in a sequential microreactor reaction after substitution of the substrate. This was the aim for the substitution reactions.

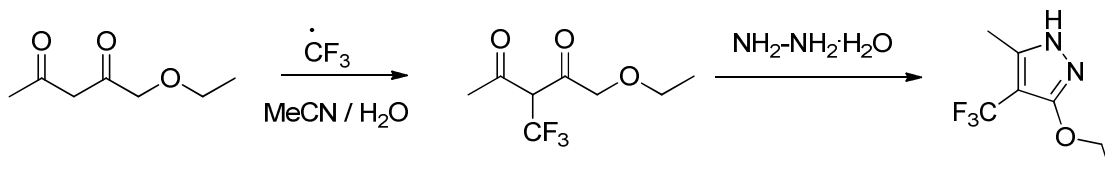

Scheme 5.24: Possible sequential reaction to form trifluoromethylated pyrazoles

The substitution of 1,3-diketones was thought to be a better example than the bistrifluoromethylation and dimerisation reactions for optimising into a sequential reaction. This was because acetonitrile and water was the solvent system and the reaction with hydrazine to form the pyrazole as shown by Sandford *et al.*³⁵ gave good yields with different solvents for the second reaction, with the best two examples being water and acetonitrile, 74 and 77%, respectively.

The synthesis was attempted with two substrates, ethyl acetoacetate, and 2,2,6,6-tetramethylheptane-3,5-dione (Scheme 5.25). These reactions have previously been demonstrated by Uneyama *et al.*⁴⁶ and Oberhammer *et al.*⁴⁷ respectively. Oberhammer *et al.*⁴⁷ showed **98** to exist mainly in the enol form **99** due to the effects of the $\text{C}(\text{CH}_3)_3$ groups.

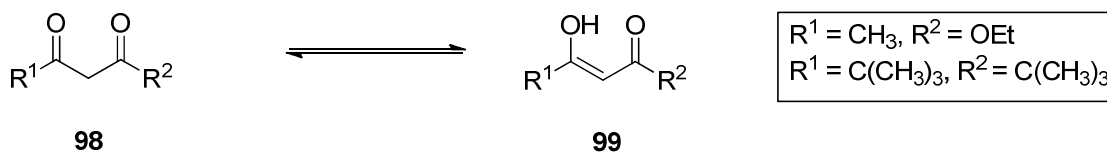
Scheme 5.25: Tautomerisation of β -diketones

First experiments were carried out with a substrate concentration of 0.1 M, 1.6 M TFA, 0.16 M NEt_3 and MeCN / H_2O as the solvent system. No experiments at a range of residence times and current densities gave any conversion to the desired substituted diketone, and only the starting material was recovered.

The solvent system was then changed to use a large excess of TFA in a ratio of $\text{H}_2\text{O} : \text{MeCN} : \text{TFA} = 0.1 : 3.0 : 1.4$ ml. Reported by Uneyama *et al.*⁴⁶ to give a 42% yield when ethyl acetoacetate was used as the substrate. Again almost no conversion of the starting material was observed, the NMR spectra showed only the starting material along with some minor impurities.

The failure of this experiment is thought to be that with the close proximity of the electrodes the enol form cannot exist long enough for the reaction to occur because it is possibly reacting directly with the electrodes. It is possible in a batch cell because the TFA is reacting at the electrodes to form the radical, and the substrate remains in the bulk of the solution where it can tautomerise.

5.3.5 Trifluoromethylacetamidation

Only preliminary work has gone into the trifluoromethylacetamidation of methyl methacrylate reported by Uneyama *et al.*⁴⁸ (Scheme 5.26). The product formed is not the dimer as when using methyl acrylate as the substrate. The low current density used in this reaction, 1 mA cm^{-2} , is said by Uneyama to electrochemically oxidise the intermediate radical **88** to the carbenium ion (Scheme 5.27) which can then react with a nucleophile, such as the solvent, acetonitrile.³⁶

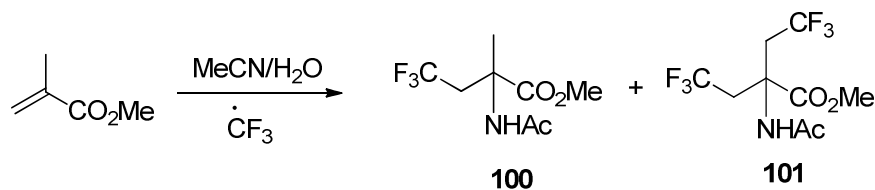

Scheme 5.26: Trifluoromethylacetamidation

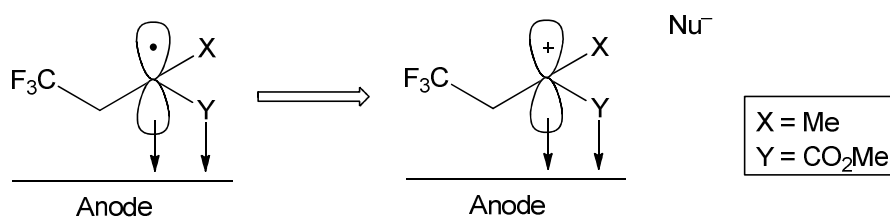
Scheme 5.27: Interaction of **89** with the electrode surface

The preliminary experiments undertaken to determine whether product formation was possible in the flow reactor were first of all at the reported 1 mA cm^{-2} , however no conversion at all was observed at this very low current density.

The current was then raised to 50 mA cm^{-2} and both NH peaks reported by Uneyama *et al.*⁴⁸ at 6.45 ppm for **100** and 6.68 ppm **101** were visible in the NMR.

At a residence time of 22 seconds the racemic products **100** and **101** were almost equal 42:58 in favour of **101**, and decreasing the residence time to 13.2 seconds the ratio changed to 3:1 in favour of **100**.

So it seems from the preliminary experiments that the mono CF₃ substituted product **100**, is formed more quickly than **101**, reported to go through a different radical intermediate than **88**. Crude NMR spectra of the reaction mixtures showed the desired products to be a minority of the crude mixture, with many other compounds visible due to the amount of singlets visible between 3.5 and 4.0 ppm which would be present due to the methoxy group present in the starting material.

5.4 Conclusions and future work

Although it was not possible to create a general set of experimental conditions for a variety of trifluoromethylation reactions in the flow cell, it has been proven to be a successful method for the addition of a trifluoromethyl group onto a series of different carbon-carbon double bonds using a relatively cheap and safe source of a trifluoromethyl group. It seems that individual optimisation would be needed to get the best results for a specific experiment due to the different interactions of the functional groups contained within the olefins under investigation. The bistrifluoromethylation needed a high current density to bind the nitrogen moiety of the substrate tightly to the electrode so that the second trifluoromethyl radical can attack, in contrast to trifluoromethylacetamidation which needs a low current density in order for the intermediate radical **89** to be further oxidised to the carbenium ion.

Following work would entail reacting a library of substrates to see exactly how successful the already established conditions for the bistrifluoromethylation and dimerisation reactions are, being the two most successful trifluoromethylation reactions.

It would also be interesting to react a series of carboxylic acids, other than TFA and substitute carbon-carbon double bonds with a series of functional groups, for example, phenyl acetic acid (Scheme 5.28).

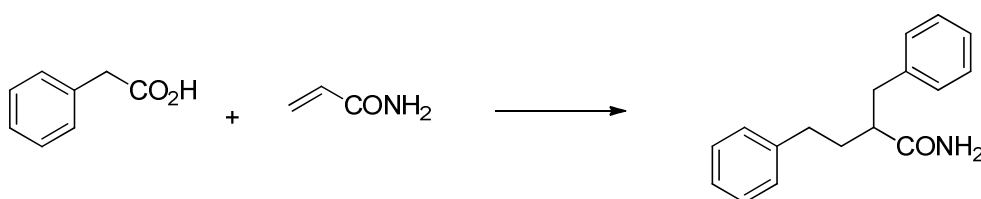

Scheme 5.28: Possible reactions of Kolbe radicals with carbon-carbon double bonds

5.5 Experimental

Melting points were obtained in open capillary tubes and are uncorrected. ¹H NMR and ¹³C NMR spectra were recorded on an AV-400 Bruker spectrometer, in the solvents indicated at 400 and 100 MHz, respectively, unless otherwise stated. Mass spectra were

recorded under the conditions of fourier transform mass spectrometry (FTMS) nano-electrospray (NSI) or atomic pressure chemical ionisation (APCI). Galvanostatic reactions were performed with a GW INSTEK GPR-30H10D galvanostat/potentiostat. No polishing of electrodes was needed, only cleaning with acetone was necessary. Acetonitrile was dried *via* a solvent purification system (SPS) when not an aqueous mixture, all other chemicals were used as purchased without further purification.

NMR experiments consist of running small volumes (3 – 4 ml) of reaction solution through the device, a normal work-up procedure would then be undertaken with the exception of a deuterated solvent being used for extraction so ^1H NMR spectra can be obtained directly.

General reaction procedure for the bistrifluoromethylation of acrylamide

A 0.1 M solution of acrylamide, containing 1.6 M TFA and 0.16 M NEt_3 in acetonitrile : H_2O (7:1) was made (10 ml solution) and introduced into the electrochemical microreactor (reactor volume 22 μL) *via* a syringe pump (flow rate 100 $\mu\text{l min}^{-1}$ / residence time 13.2 seconds) with an applied current of 200 mA cm^{-2} . The reaction was allowed to reach equilibrium and the solution was collected at the outlet. The solution was then neutralised with NaHCO_3 and the solvent was removed. The aqueous solution was then extracted 3 times with EtOAc and the combined organic extracts were washed with water and brine and dried through a phase separator. The solvent was removed *in vacuo* and the resulting residue was subjected to flash column chromatography (*n*-hexane – ethyl acetate) to give the bistrifluoromethylated product **90** 66% (9.8 ml collected in 98 min to give 135 mg).

General reaction procedure for the dimerisation of methacrylate

A 0.1 M solution of methacrylate, containing 0.9 M TFA and 0.09 M NEt_3 in acetonitrile: H_2O (7:1) was made (10 ml solution) and introduced into the electrochemical microreactor (reactor volume 22 μL) *via* a syringe pump (flow rate 80 $\mu\text{l min}^{-1}$ / residence time 16.5 seconds) with an applied current of 80 mA cm^{-2} . The reaction was allowed to reach equilibrium and the solution was collected at the outlet.

The solvent was removed and the aqueous solution was then extracted 3 times with EtOAc. The combined organic extracts were washed with water and brine and dried through a phase separator. The solvent was removed *in vacuo* and the resulting residue was subjected to flash column chromatography (*n*-hexane – ethyl acetate) to give a mixture of 2 isomers **93a**, **93b** 47% (9.6 ml collected in 96 mins to give 140 mg of **93a** and **93b**) The 2 isomers could then be separated by repeated recrystallisation from *n*-hexane (**93a**) or pentane (**93b**).

4,4,4-Trifluoro-2-(trifluoromethyl)butanamide (**90**)⁴¹

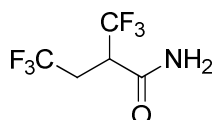

White solid m.p.: 89-91 °C; ¹H NMR (400 MHz, CDCl₃): δ = 2.42-2.54 (m, 1H, CH), 3.03-3.27 (m, 2H, CH₂), 5.66 (br s, NH), 5.73 (br, s, NH) ppm; ¹³C NMR (100 MHz, CDCl₃): δ = 30.4 (q, ²J_{C,F} = 31.1 Hz, CH₂), δ = 45.2 (q, ²J_{C,F} = 28.1 Hz, CH), 125.5 (m, 2 x CF₃), 165.5 ppm (C=O); FTMS APCI [M + H⁺] calcd. for C₅H₆F₆NO = 120.0348; found – 120.0348.

Dimethyl 2,3-bis(2,2,2-trifluoroethyl)succinate (meso) (**93a**)⁴³

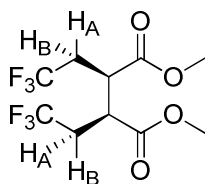

White solid m.p.: 87-88 °C; ¹H NMR (400 MHz, CDCl₃): δ = 2.11-2.23 (m, 2H, H_A), 2.67-2.81 (m, 2H, H_B), 3.03-3.06 (m, 2H, 2 x CH), 3.75 (s, 6H, 2 x O-CH₃) ppm; ¹³C NMR (100 MHz, CDCl₃): δ = 33.4 (q, ²J_{C,F} = 29.8 Hz, 2 x CH₂), 41.0 (2 x CH), 52.8 (2 x CH₃), 126.0 (q, ¹J_{C,F} = 276.0 Hz, 2 x CF₃), 171.2 (C=O) ppm; FTMS NSI [M + NH₄] calcd. for C₁₀H₁₆F₆NO₄ = 328.0978; found – 328.0982.

Dimethyl 2,3-bis(2,2,2-trifluoroethyl)succinate (dl) (**93b**)⁴³

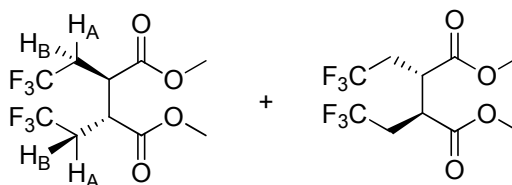

White solid m.p.: 53-54 °C; ¹H NMR (400 MHz, CDCl₃): δ = 2.34-2.47 (m, 2H, H_A), 2.73-2.88 (m, 2H, H_B), 3.06-3.09 (m, 2H, 2 x CH), 3.76 (s, 6H, 2 x CH₃) ppm; ¹³C NMR (100 MHz, CDCl₃): δ = 33.0 (q, ²J_{C,F} = 29.6), 40.4 (2 x CH), 40.5 (2 x CH₂), 52.8 (2 x CH₃), 125.8 (q, ¹J_{C,F} = 276.7 Hz, 2 x CF₃), 171.1 (C=O) ppm; FTMS APCI [M + H⁺] calcd. for C₁₀H₁₃F₆O₄ = 311.0713; found -311.0713.

2-(Trifluoromethyl)succinonitrile (**94**)⁴⁵

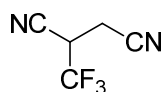

¹H NMR (400 MHz, CDCl₃): δ = 3.02 (d, 2H, J = 7.0, CH₂), 3.75 (m, 1H, CH) ppm.

Succinonitrile (**96**)⁴⁵

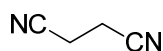

White solid, m.p.: 52 -56 °C (lit. 57 °C); ¹H NMR (400 MHz, CDCl₃): δ = 2.77 (s, 4H, 2 x CH₂) ppm; ¹³C NMR (100 MHz, CDCl₃): δ = 14.6 (2 x CH₂), 115.9 (2 x CN) ppm.

Butane-1,2,3,4-tetracarbonitrile (**97**)⁴⁵

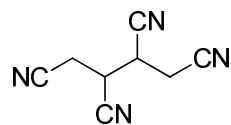

Brown solid, m.p.: 115-118 °C (lit. 120 °C); ¹H NMR (400 MHz, DMSO): δ = 3.13-3.27 (m, 4H, 2 x CH₂), 3.87-3.92 (m, 2H, 2 x CH) ppm; ¹³C NMR (100 MHz, DMSO): δ = 18.7 (2 x CH₂), 29.8 (2 x CH), 116.4 (2 x CN), 116.6 (2 x CN) ppm.

5.6 References

1. G. Gribble, in *Organofluorines, The Handbook of Environmental Chemistry*, ed. A. H. Neilson, Springer-Verlag, 2002, vol. 3.
2. J. Schmedt auf der Günne, M. Mangstl, and F. Kraus, *Angew. Chemie, Int. Ed. English*, **2012**, *51*, 7847.
3. F. Swarts, *Bull. L'academie R. Des Sci.*, **1892**, *24*, 309.
4. V. Dinoiu, *Rev. Roum. Chim.*, **2006**, *51*, 1141.
5. W. R. Dolbier, *J. Fluor. Chem.*, **2005**, *126*, 157.
6. J. Hulliger, R. Berger, G. Resnati, P. Metrangolo, and E. Weber, *Chem. Soc. Rev.*, **2011**, *40*, 3496.
7. P. Kirsch and M. Bremer, *Chemphyschem*, **2010**, *11*, 357.
8. P. Kirsch and M. Bremer, *Angew. Chemie, Int. Ed. English*, **2000**, *39*, 4216.
9. K. L. Kirk, *Org. Process Res. Dev.*, **2008**, *12*, 305.
10. K. Müller, F. Diederich, and C. Faeh, *Science*, **2007**, *317*, 1881.
11. N. N. Greenwood, *Chemistry of the Elements*, Elsevier, 3rd ed.
12. V. Gouverneur, S. Purser, P. Moore, and S. Swallow, *Chem. Soc. Rev.*, **2008**, *37*, 320.
13. M. Morgenthaler, E. Schweizer, A. Hoffmann-Röder, F. Benini, R. E. Martin, G. Jaeschke, B. Wagner, H. Fischer, S. Bendels, D. Zimmerli, J. Schneider, F. Diederich, M. Kansy, and K. Müller, *ChemMedChem*, **2007**, *2*, 1100.

14. B. E. Smart, *J. Fluor. Chem.*, **2001**, *109*, 3.
15. A. M. Elizarov, R. M. Van Dam, Y. S. Shin, H. C. Kolb, C. Padgett, D. Stout, J. Shu, J. Huang, A. Daridon, and R. James, *J. Nucl. Med.*, **2010**, *51*, 282.
16. S. T. Purrington, B. S. Kagen, and T. B. Patrick, *Chem. Rev.*, **1986**, *86*, 997.
17. T. Furuya, C. A. Kuttruff, and T. Ritter, *Curr. Opin. Drug Discov. Dev.*, **2008**, *11*, 803.
18. G. S. Lal, G. P. Pez, and R. G. Syvret, *Chem. Rev.*, **1996**, *96*, 1737.
19. A. S. Kiselyov, *Chem. Soc. Rev.*, **2005**, *34*, 1031.
20. C.-H. Wong, P. T. Nyffeler, S. G. Durón, M. D. Burkart, and S. P. Vincent, *Angew. Chemie, Int. Ed. English*, **2004**, *44*, 192.
21. J. Simons, *J. Electrochem. Soc.*, **1945**, *95*, 47.
22. K. Dawood, *Tetrahedron*, **2004**, *60*, 1435.
23. V. Dinoiu, *Rev. Roum. Chim.*, **2007**, *52*, 453.
24. M. Noel, V. Suryanarayanan, and S. Chellammal, *J. Fluor. Chem.*, **1997**, *83*, 31.
25. N. Yoneda, *J. Fluor. Chem.*, **2000**, *105*, 205.
26. R. Haszeldine, *J. Chem. Soc.*, **1949**, 2856.
27. A. Studer, *Angew. Chemie, Int. Ed. English*, **2012**, *51*, 2.
28. J. M. Shreeve and R. P. Singh, *Tetrahedron*, **2000**, *56*, 7613.
29. G. K. S. Prakash and A. K. Yudin, *Chem. Rev.*, **1997**, *97*, 757.
30. N. Shibata, A. Matsnev, and D. Cahard, *Beilstein J. Org. Chem.*, **2010**, *6*.
31. T. Gustafsson, R. Gilmour, and P. H. Seeberger, *Chem. Commun.*, **2008**, 3022.
32. K. Dax, M. Albert, W. Repetschnigg, J. Ortner, J. Gomes, B. J. Paul, C. Illaszewicz, H. Webber, and W. Steiner, *Carbohydr. Res.*, **2000**, *326*, 395.
33. M. Shreeve and R. Singh, *Synthesis*, **2002**, *17*, 2561.
34. R. D. Chambers and R. C. H. Spink, *Chem. Commun.*, **1999**, *2*, 883.

35. G. Sandford, J. R. Breen, D. S. Yufit, J. a K. Howard, J. Fray, and B. Patel, *Beilstein J. Org. Chem.*, **2011**, 7, 1048.
36. K. Uneyama, *Tetrahedron*, **1991**, 47, 555.
37. R. N. Renaud and D. E. Sullivan, *Can. J. Chem.*, **1972**, 50, 3084.
38. N. Renaud and E. Sullivan, *Can. J. Chem.*, **1972**, 51, 772.
39. N. Renaud and J. Champagne, *Can. J. Chem.*, **1975**, 53, 529.
40. R. Renaud, P. Champagne, and M. Savard, *Can. J. Chem.*, **1979**, 57, 2617.
41. K. Uneyama, O. Morimoto, and H. Nanbu, *Tetrahedron Lett.*, **1989**, 30, 109.
42. T. Nonaka, P. Cheng, and K. Uneyama, *Denki Kagaku*, **1991**, 59, 427.
43. K. Uneyama, S. Makio, H. Nanbu, and A. Chemistry, *J. Org. Chem.*, **1989**, 54, 872.
44. A. Pedler, C. Brookes, P. Coe, and J. Tatlow, *J. Chem. Soc. Perkin Trans. 1*, **1978**, 202.
45. K. Uneyama and S. Watanabe, *J. Org. Chem.*, **1990**, 55, 3909.
46. K. Uneyama and K. Ueda, *Chem. Lett.*, **1988**, 853.
47. H. Oberhammer, N. V Belova, and G. V Girichev, *J. Phys. Chem. A*, **2004**, 108, 3593.
48. K. Uneyama and H. Nanbu, *J. Org. Chem.*, **1988**, 53, 4598.

Chapter 6

Conclusions

6. Conclusions

An initial prototype of an electrochemical microreactor was designed fabricated from the brief that it should be able to be dismantled with ease, for cleaning purposes, and to have a circular design to ensure equal pressure around the device. Once the second prototype was constructed from aluminium, to solve problems with leaking of the first PEEK prototype, known electrochemical reactions were carried out to prove it functioned correctly.

With a fully working microreactor in hand, electroorganic reactions were carried out to find out what type of reactions could be carried out in an undivided flow cell. The first successful reactions undertaken were that of synthesising diaryliodonium salts from aryl and iodoaryl substrates. The reaction was limited to substrates with alkyl groups only. Yields achieved in most cases were lower than that reported using a batch cell. This was found to be due to the formation of side products from the aryl substrate being oxidised and undergoing a Ritter reaction with the solvent system, which was not observed in a batch environment, and shows a disadvantage of the flow cell. This work was published in the Beilstein Journal of Organic chemistry.

Reactions using electrochemical mediators were also achieved in the flow cell. Firstly the Hofmann rearrangement of amides to carbamates. Yields achieved were comparable to that reported in a batch cell and in the case of **51**, the yield was almost 30% higher. The general procedure could not be optimised for the different alcohols so each reaction would have to be optimised individually. As no increase in yield could be achieved, only the benefits of continuous processing could be added to the batch synthesis. Other reactions using electrochemical mediators were the oxidation of secondary alcohols, but again the yields were lower than reported for the batch synthesis.

The final syntheses carried out were the trifluoromethylation of electron deficient alkenes using trifluoroacetic acid, a cheap and relatively safe form of the trifluoromethyl radical. The bistrifluoromethylation of acrylamide turned out to be more successful than both the previously reported batch and flow yields. Dimerisation reactions of methyl acrylate were also carried out and yields were similar to that achieved in batch. Also initial reactions for the

trifluoromethylacetamidation of methyl methacrylate showed that the products could be formed in the flow cell. Part of this work has now been published in Chem Open, and also shows difluoromethylation and reactions with a range of substrates. Not all trifluoromethylation reactions previously reported could be replicated in the flow device. Substitution reactions were unsuccessful and the hydrotrifluoromethylation reactions were very inefficient, forming mainly the side products with only traces of the desired products.

The electrochemical microreactor has been shown to be a success, a new technology being utilised by a simple and inexpensive design. The device was able to undertake a number of different electroorganic reactions. One important factor in the success of the device has been reproducibility of results, showing that the device functions correctly.

Certain parts of the device could be improved, the device cannot be directly connected to sequential reaction mixer because a build-up of back pressure is observed and the device will leak. Also if the device is submerged in an ice bath it will leak, presumably due to seals not being tight enough, possibly the PEEK connectors for the inlet and outlet tubing. There is also room for development of the device. Electrodes of different materials, such as graphite, could be constructed and inserted into the device. There is also the possibility that the device could be modified into a divided electrochemical cell. This would stop the counter reactions of the opposing electrode and possibly increase the yields achieved, while allowing for a larger range of electroorganic reactions to be carried out.

7. Appendices

Part A

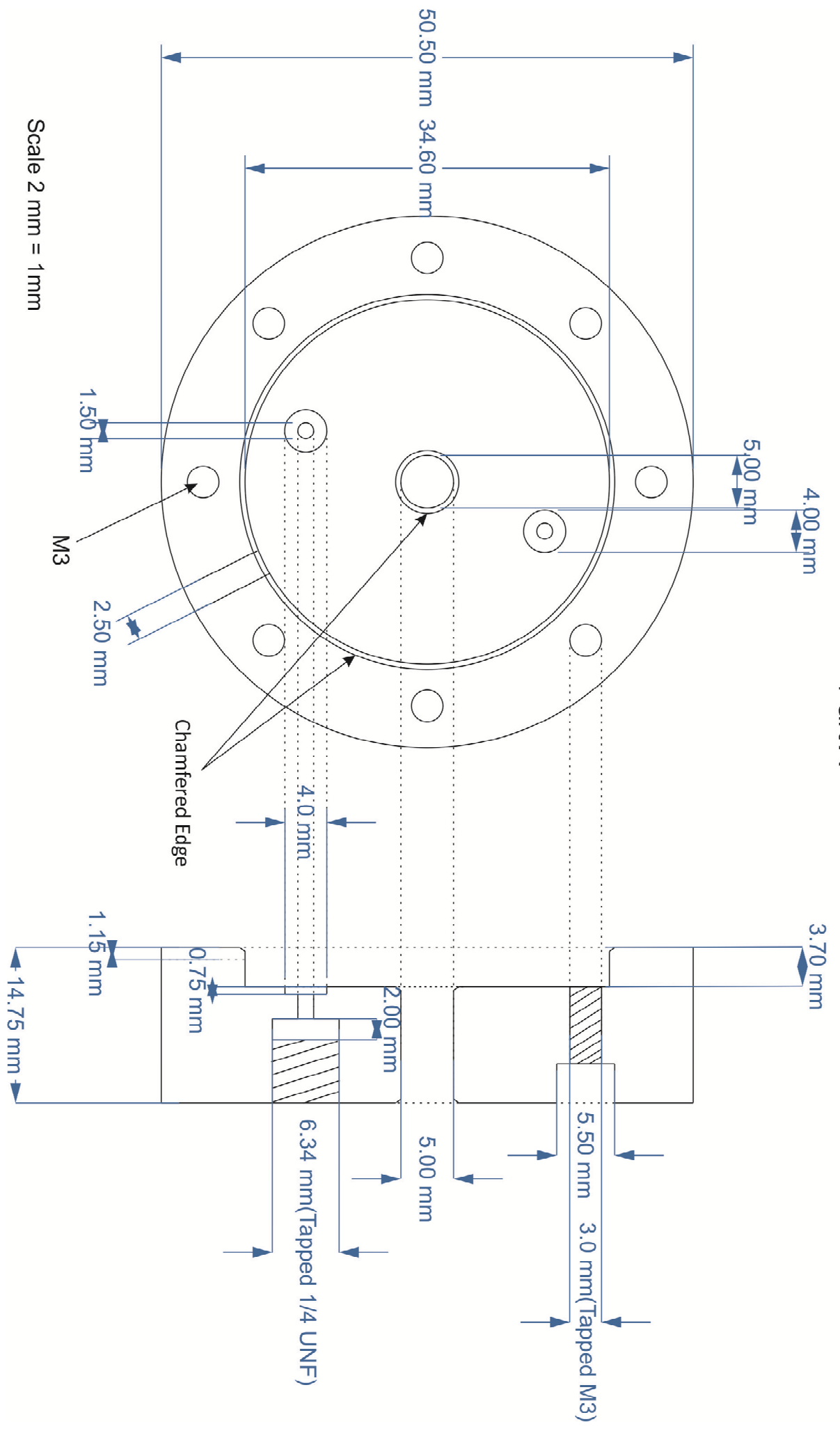

Scale 2 mm = 1 mm

