

This is an Open Access document downloaded from ORCA, Cardiff University's institutional repository:<https://orca.cardiff.ac.uk/id/eprint/106037/>

This is the author's version of a work that was submitted to / accepted for publication.

Citation for final published version:

Lin, Junyi, Spiegler, Virginia L. M. and Naim, M. M. 2018. Dynamic analysis and design of a semiconductor supply chain: a control engineering approach. *International Journal of Production Research* 56 (13) , pp. 4585-4611. 10.1080/00207543.2017.1396507

Publishers page: <http://dx.doi.org/10.1080/00207543.2017.1396507>

Please note:

Changes made as a result of publishing processes such as copy-editing, formatting and page numbers may not be reflected in this version. For the definitive version of this publication, please refer to the published source. You are advised to consult the publisher's version if you wish to cite this paper.

This version is being made available in accordance with publisher policies. See <http://orca.cf.ac.uk/policies.html> for usage policies. Copyright and moral rights for publications made available in ORCA are retained by the copyright holders.



Dynamic analysis and design of a semiconductor supply chain: a control engineering approach

Junyi Lin,

*Logistics Systems Dynamics Group, Cardiff Business School, Cardiff University, Cardiff, UK.
linj17@cardiff.ac.uk*

Virginia L.M. Spiegler,

*Management Science Research Group, Kent Business School, University of Kent, Canterbury, UK.
v.l.spiegler@kent.ac.uk*

M.M. Naim

*Logistics Systems Dynamics Group, Cardiff Business School, Cardiff University, Cardiff, UK
naimmm@cardiff.ac.uk*

Dynamic analysis and design of a semiconductor supply chain: a control engineering approach

The combined make-to-stock and make-to-order (MTS-MTO) supply chain is well-recognized in the semiconductor industry in order to find a competitive balance between agility, including customer responsiveness, and minimum reasonable inventory, to achieve cost efficiency while maintaining customer service levels. Such a hybrid MTS-MTO supply chain may suffer from the bullwhip effect, but few researchers have attempted to understand the dynamic properties of such a hybrid system. We utilize a model of the Intel supply chain to analytically explore the underlying mechanisms of bullwhip generation and compare its dynamic performance to the well-known Inventory and Order Based Production Control System (IOBPCS) archetype. Adopting a control engineering approach, we find that the feedforward forecasting compensation in the MTO element plays a major role in the degree of bullwhip and the Customer Order Decoupling Point (CODP) profoundly impacts both the bullwhip effect and the inventory variance in the MTS part. Thus, managers should carefully tune the CODP inventory correction and balance the benefit between CODP inventory and bullwhip costs in hybrid MTS-MTO supply chains.

Keywords: Make-to-Stock, Make-to-Order, hybrid MTS-MTO, semiconductor industry, IOBPCS family

1. Introduction

Facing a highly volatile and turbulent business environment, caused by reduced product life cycles and the unpredictable and customized demand, agile supply chains have become a key capability for current businesses to survive and thrive (Braunscheidel and Suresh 2009). On the other hand, the pressure of leaner supply chains forces practitioners to focus on minimum reasonable inventory (MRI) (Grünwald and Fortuin 1992) and on corresponding issues, such as forecasting accuracy and safety stock (Dudek and Stadtler 2005; Gunasekaran, Patel, and McGaughey 2004).

This is the case in the capital-intensive semiconductor industry characterized by a short product life cycle, wide product variety due to overlapping product life cycles for different customers, long fabrication lead times and complex production processes (Geng and Jiang 2009). To find a competitive balance between agility (customer responsiveness) and MRI (cost efficiency), the combination of make-to-stock and make-to-order (MTS-MTO), also called the hybrid push-pull strategy, has been considered in the semiconductor industry (Lee et al. 2006; Hur, Bard and Chacon 2017). A hybrid MTS-MTO approach refers to the supply chain strategy of postponing the customization of products at different levels until the actual customer orders are received (Kim et al. 2012). The boundary between MTO and MTS, called the ‘Customer Order Decoupling Point’ (CODP) (Naylor, Naim, and Berry 1999; Harrison, Lee, and Neale 2005) or ‘order penetration point’ (Olhager 2003; Christopher 2016), is the point that separates the forecasting-based MTS element that pushes semi-finished products, and the order-based MTO part that pulls products through for the customization process (Chen and Dong 2017).

Although such a hybrid MTS-MTO strategy has been well-recognized in the semiconductor industry, few studies have focused on understanding the hybrid MTS-MTO environment from a supply chain dynamics perspective. Most literature on the modelling and analysis of the hybrid MTS-MTO strategy in the semiconductor industry has explored scheduling and control (Chang et al. 2003; Wang, Rivera, and Kempf 2007), the theoretical and empirical development of a hybrid MTS-MTO model (Brown, Lee, and Petrakian 2000; Lee et al. 2006) and postponement analysis (Kim and Kim 2012). Semiconductor firms have suffered severely from demand amplification, or the bullwhip effect (Hofmann 2017; Li and Disney 2017; Vicente, Relvas and Barbosa-Póvoa 2017), due to their relatively extreme distance in the entire supply chain from end customers (Brown, Lee, and Petrakian 2000), as well as the characteristics of high levels of stochasticity and nonlinearity (Wang and Rivera 2008). For this reason, we aim to explore analytically the underlying mechanisms of supply chain dynamics within the context of the semiconductor industry. We use the supply chain model of Intel, the leader in microprocessor manufacturing (Sampath et al. 2015), as reported empirically by Gonçalves, Hines,

and Sterman (2005), as a base framework to extract and analyse the MTS-MTO supply chain. Moreover, we benchmark the MTS-MTO model’s dynamic behaviour with a well-established supply chain family of model archetype, the inventory and order-based production control (IOBPCS) (Towill 1982; John, Naim, and Towill 1994; Sarimveis et al. 2008; Lin et al. 2016).

In doing so, we address the following research questions:

1. *How can we gain insight into the dynamic properties of a semiconductor hybrid MTS-MTO supply chain as personified by the Intel model?*
2. *What are the underlying mechanisms of the dynamic behaviour in a semiconductor hybrid MTS-MTO supply chain and how can these dynamics be mitigated?*

Figure 1 illustrates our research approach. We first model the Intel supply chain in a block diagram form based on the model descriptions given by Gonçalves, Hines and Sterman (2005). Although their model provided insights into lean inventory and responsive utilization policies, their simulation approach is not able to reveal the explicit relationship between the system’s outputs and the endogenous demand, therefore overlooking the real effects of some control parameters. After simplifying the block diagram and extracting the MTS-MTO scenario (push-pull), we analyse the dynamic behaviour of the system by finding the system’s transfer functions. The simplified model enables us to draw an analogy with known archetypes of the IOBPCS family and to propose policies to overcome trade-offs in the system output responses. Although we investigate the dynamic behaviour of the hybrid MTS-MTO model within the Intel supply chain, the insights gained from the analytical results can be generalized to other high-volume and low-variety semiconductor supply chains.

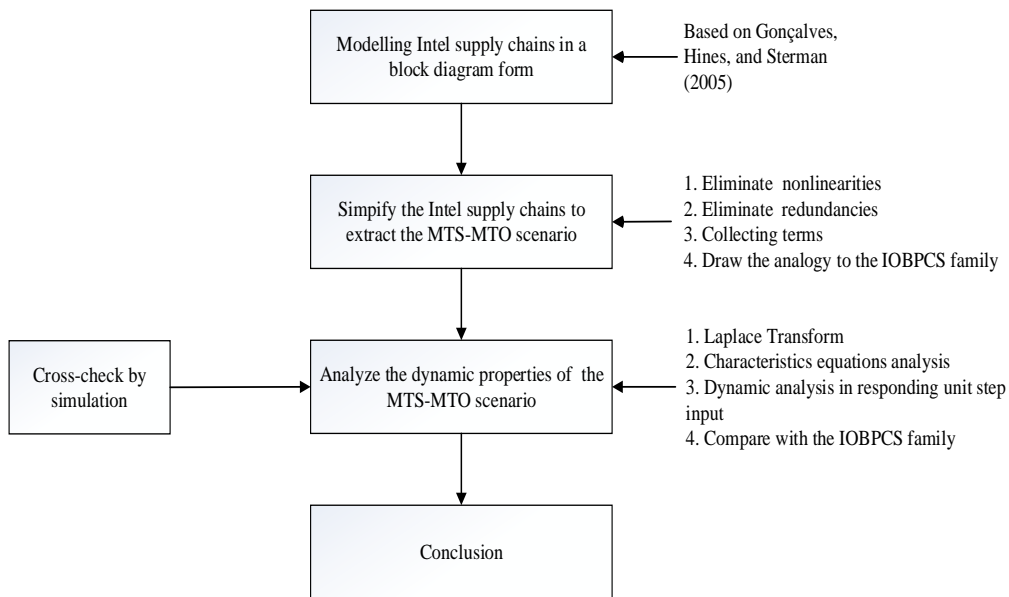

Figure 1. The research approach.

2. Literature review

2.1 The hybrid MTS-MTO strategy in semiconductor production strategy

Although the complex material and equipment acquisition processes vary between different companies, a typical semiconductor manufacturing process consists of three main stages: wafer fabrication (‘front-end’ manufacturing), assembly and test, and product distribution (‘back-end’ operations), whose associated activities are usually involved in a globally-complex network to save labour costs and benefit from tax breaks (Rastogi et al. 2011). Depending on the time horizon, production planning and control in the semiconductor industry can be divided from yearly-based planning, monthly/weekly-based order release to daily scheduling and hourly dispatching (Mönch,

Fowler and Mason 2013). As this study focuses on mid-/long-term production planning, we review the main operational strategies adopted for such planning periods and order release procedures.

At a detailed machine level, extensive literature has studied the push, pull or hybrid order release approaches for semiconductor wafer fabrication, in which the push strategy refers to the production approach based on desired quantity of goods, while pull-based methods focus on what can be produced based on real-time demand and resource constraints. The authors refer to; Chandra and Gupta (1997); Bahaji and Kuhl (2008); Qi, Sivakumar, and Gershwin (2008); Lin and Lee (2011) and Zhang Bard and Chacon (2017) for details. From a broader and more strategic supply chain operational perspective, there are three strategies commonly considered by the semiconductor industry: MTS, MTO or ATO (assembly-to-order, that is, a kind of hybrid MTS-MTO that places the decoupling point at the assembly echelon) (Forstner and Mönch 2013; Sun et al. 2010). Utilizing a case study, Brown et al. (2000) highlighted the benefit of implementing the hybrid MTS-MTO for better financial performance via holding less finished inventory. Lee (2001) discussed the consequences of implementing a hybrid production strategy with die bank as the decoupling point in the semiconductor context and recommended a postponement strategy for operating such complex supply networks. Sun et al. (2010) proposed a hierarchical decision support framework to guide the selection of MTS, MTO or ATO strategies for designing semiconductor supply chains. The results indicated that the decision is driven by two customer-oriented factors, i.e. required lead time and the importance of on-time delivery performance, although customer demand patterns and process variability may play an important role under certain circumstances. Forstner and Mönch (2013) developed a genetic algorithm (GA) to support the selection of different production strategies (i.e. MTS, MTO, ATO) by using discrete event simulation. A profit-based objective function is developed under the consideration of stochastic behaviour of the semiconductor supply chain, although GA is criticized as a time-consuming procedure to assess the fitness of the right production strategy.

While previous research has explored the possible benefits and selection criteria for different supply chain operational strategies in the semiconductor industry, very few studies focus on the dynamic behaviour of the hybrid MTS-MTO strategy, except for Gonçalves, Hines, and Sterman (2005); Orcun, Uzsoy, and Kempf (2006) and Orcun and Uzsoy (2011). Specifically, Gonçalves, Hines, and Sterman (2005) developed a system dynamics simulation model to explore how market sales and production decisions interact to create unwanted production and inventory variances in the Intel hybrid MTS-MTO supply chain. Using a system dynamics approach, Orcun, Uzsoy and Kempf (2006) developed a capacitated semiconductor production model with load-dependent lead time, which overcomes the limitation of treating lead times as exogenous parameters independent of the decision variables that most linear dynamic models assume. The analysis suggested that the nonlinear change at high capacity utilization is consistent with insights from queuing models and industrial practices. Furthermore, Orçun and Uzsoy (2011) studied the dynamic behaviour of a simplified semiconductor supply chain system with two capacitated manufacturing echelons and one inventory echelon. They indicated that the dynamic properties of a supply chain system under optimization-based planning models are qualitatively different from those operating under simple feedback policies system dynamics models.

Although these system dynamics simulations contribute to the representation of a real system by incorporating nonlinear components and complex structures, it is a trial-and-error approach that may hinder the system improvement process (Towill 1982; Sarimveis et al. 2008). Despite the fact that semiconductor supply chains have suffered severely from the bullwhip effect (Chien, Chen, and Peng 2010; Terwiesch et al. 2005), limited effort has been made to explore the underlying system structures that cause the phenomenon. As a result, there is a need to consider analytical methods to understand the underlying mechanisms of bullwhip generation and propose corresponding mitigation approaches that are relevant for the semiconductor hybrid MTS-MTO supply chain.

2.2 Classic control theory and the IOBPCS family in studying supply chain dynamics

Classic control theory techniques, with feedback thinking and sufficient analytical tools, are advantageous for analysing supply chain dynamics (Sarimveis et al. 2008). The application of classic control theory in a production system can be traced back to Simon (1952). Table 1 gives a brief introduction of control engineering relevant tools/methods utilized in this study.

<i>Tools/Methods</i>	<i>Description and advantages</i>	<i>References (e.g.)</i>
Block diagram	Block diagrams are used to outline a system in which the principal parts or functions are represented by blocks connected by lines that show the relationships of the blocks.	Schwarzenbach and Gill (1992)
	The Block diagrams are useful to describe the overall concept of a complex system without concerning the details of implementation, which allow for both a visual and an analytical representation within a single entity. The adoption of block diagrams in studying supply chain dynamics has been well-recognized in production planning and control literature.	Disney and Towill (2002); Dejonckheere et al. (2004); Spiegler et al. (2016)
Laplace transformation	The Laplace transform is an integral transform in which convert a function of a real variable t (time domain) to a function of a complex variable s (frequency domain), shown as follow: $F(s) = \int_0^{\infty} e^{-st} f(t) dt$	Schwarzenbach and Gill (1992)
	The Laplace transform technique has great advantages of simplifying the algebraic manipulations required, analysing large systems, handling arbitrary inputs and benchmarking good practice in studying supply chain dynamics.	Disney and Towill (2002); Disney, Towill, and Warburton (2006)
Transfer function	The transfer function of a system is a mathematical representation describing the dynamic behaviour in a linear, time-invariant (LTI) system algebraically. It can be defined as the ratio of s/z transform of the output variables to the s/z-transform of the input variables, depending on the consideration of variables change with time continuously or discretely.	Nise (2007)
	1. The transfer function approach can be used to model production/supply chain systems, since they can be seen as systems with complex interactions between different parts of the chain. 2. Transfer functions completely represent the dynamic behaviour of production/supply chain systems under a particular replenishment rule, i.e. the input to the system represents a specific demand pattern and the output refers to the corresponding replenishment or production orders.	Dejonckheere et al. (2003); Spiegler, Naim, and Wikner (2012)

Table 1. A brief review of control engineering tools/methods utilized in this study.

By adopting classic control theory, Towill (1982) translated Coyle (1977) system dynamics work to represent the IOBPCS in a block diagram form. John, Naim, and Towill (1994) then extended the original model to the automatic pipeline, inventory and order-based production control system (APIOBPCS) by incorporating an automatic work-in-progress feedback loop. These two original models and their variants, i.e. the IOBPCS family, have been recognized as a base framework for production planning and control systems, as they consist of general laws that represent many supply chain contexts, such as the famous beer game decision-making heuristic (Sterman 1989), the order-up-to (OUT) policy represented by APVIOBPCS (Automatic pipeline and various inventory and order-based production control system) (Chen and Disney 2007; Zhou, Disney, and Towill 2010), remanufacturing system (Zhou et al. 2006; Zhou, Naim, and Disney 2017) and various other industrial applications (e.g. Coyle 1977). The authors refer to Lin et al. (2016) for a full review of the IOBPCS family in studying supply chain dynamics. We will show an analogy between the IOBPCS family and the Intel supply chain model to explore the underlying mechanisms of the dynamic properties in the hybrid MTS-MTO system and propose corresponding mitigation strategies.

3. The Intel supply chain model

3.1 Model description

A_G	Gross assembly completion rate	pull A_G	Governs A_G in pull mode
A^*_G	Desired A_G	push A_G	Governs A_G in push mode
A_N	Net assembly completion rate	S	Actual shipments
A^*_N	Desired A_N	S*	Desired shipments
AWIP	Assembly work in process	S_{MAX}	Feasible shipments
AWIP*	Desired AWIP	WOI*	Desired weeks of Inventory = $T_{OP} + T_{SS}$
AWIP_{ADJ}	AWIP adjustment	WS	Wafer starts = WS^*
B	Backlog	WS*	Desired wafer starts
B*	Target backlog	WS_N*	Desired net WS
B_{ADJ}	B adjustment	Y_D	Die yield
D	Actual order	Y_L	Line yield
D_i*	Desired die inflow	Y_U	Unit yield
DD*	Desired delivery delay	T_{DAdj}	Forecasting smoothing constant
D_i	Die completion rate	T_A	Assembly time
DPW	Die per wafer	T_B	Time to adjust backlog
ED	Long-term demand forecast	T_{AWIP}	Time to correct AWIP discrepancy
ES	Expected shipments	T_F	Fabrication time
F_G	Gross fabrication rate	T_{FGI}	Time to adjust FGI discrepancy
FGI	Finished goods inventory stock	T_{FWIP}	Time to adjust FWIP discrepancy
FGI*	Target FGI	T_{OP}	Information process time (Delay before shipments)
FGI_{ADJ}	FGI adjustment	T_{sAdj}	Shipping smoothing constant
FWIP	Fabrication work in process	T_{SS}	Safety stock coverage
FWIP*	Desired FWIP	FWIP_{ADJ}	FWIP adjustment
IOBPCS	Inventory and order-based production control system		
VIOPCS	Variable inventory and order-based production control system		
APIOBPCS	Automatic pipeline and inventory and order-based production control system		
APVIOBPCS	Automatic pipeline and various inventory and order-based production control system		

Table 2. Variables, constants and model descriptors used in the semiconductor supply chain model.

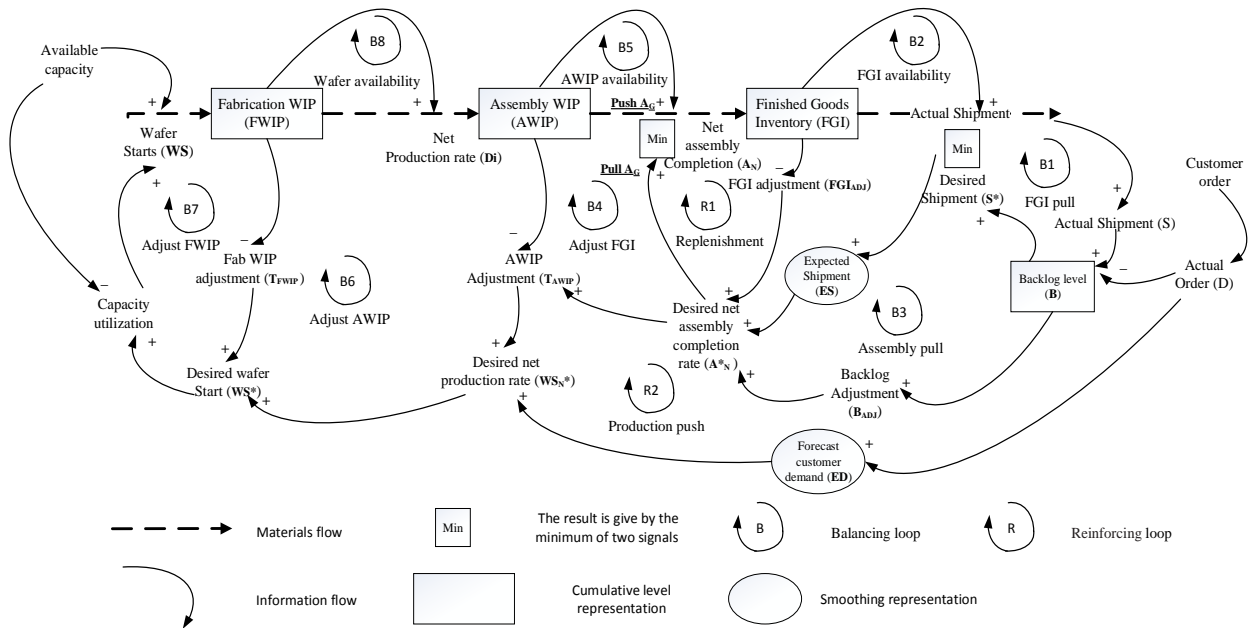

Figure 2. Basic structure of the production-inventory based semiconductor supply chain system. Based on Gonçalves, Hines, and Sterman (2005)

Figure 2 presents the basic material and information flows for the Intel supply chain including fabrication, assembly and distribution (Gonçalves, Hines, and Sterman 2005). All the nomenclature and model descriptors utilized in this paper are presented in Table 2. It should be noted that the dynamic influence of customers' response, i.e. the customers' response to supply availability measured by the fraction of order fulfilment, is not considered as we only focus on the effect of dynamic production and inventory control in the Intel supply chain model. Here we give a brief introduction to the supply chain operational design, while full details can be found in Gonçalves, Hines, and Sterman (2005).

Specifically, there are two main manufacturing stages for microprocessor chip production from a material flow perspective: fabrication and assembly. The polished disk-shaped silicon substrates (wafers) as inputs are taken into a wafer fabrication facility, and through several complicated sequences to produce fabricated wafers (composed of integrated circuits, i.e. ICs or dies). A vertical cross-section of an integrated circuit reveals several layers formed during the fabrication process. Lower layers include the critical electrical components (e.g. transistors, capacitors), which are produced at the 'front-end' of the fabrication process. Upper layers, produced at the 'back-end' of the fabrication process, connect the electrical components to form circuits. In the second assembly phase, the fabricated wafers are cut into dies and stored in the ADI warehouse to wait for the assembly process. After passing assembly and test plants to ensure operability, the finished microprocessors are stored in the FGI for customer orders. A three-stage supply chain, including fabrication, assembly and distribution, is thereby created to represent the manufacturing process.

Regarding the information flow, the hybrid MTS-MTO information control strategy is implemented. The downstream assembly and distribution systems are essentially the MTO mode in which end customers' orders pull the available microprocessors from FGI if there are sufficient FGI and AWIP. The upstream wafer fabrication, however, is characterized by the MTS production style: long-term demand forecasting and the adjustment from downstream AWIP and FWIP to determine the desired wafer production rate.

The exogenous demand into the supply chain system begins when end customers' demand information is transmitted into the information system and tracked until it is shipped or cancelled. The actual shipment, S , is determined by the minimum value between S^* and S_{MAX} . By design, the distribution system operates as the MTO mode in which the S^* is given by the ratio of B and DD^* .

However, if insufficient FGI constrains S^* , the distribution system will automatically switch to the MTS mode to push all feasible FGI, which is estimated by FGI stock and T_{OP} . As a result, those backlogged orders directly pull product components from AWIP to increase the assembly order rate, under the condition that the assembly system still performs the MTO-based production with enough AWIP. The delivery delay experienced by external customers is increased in such scenarios, since required orders cannot be fulfilled directly by FGI and it takes longer to assemble and distribute those backlogged orders.

While shipments deplete FGI, the A_N , defined by the A_G and Y_U , replenishes it. A_G is determined by the minimum of pull A_G and push A_G signal. By design, pull A_G is given by the desired pull signal under the MTO operation in the assembly system, i.e. A_N^* adjusted by Y_U . A_N^* is determined by the summation of the recent shipment, FGI adjustment and B adjustment. If all available AWIP still constrains the assembly activities, the assembly system can only complete what are feasible and thereby switch to the MTS production model, i.e. push A_G , which is estimated by the ratio between current AWIP and T_A .

The upstream fabrication plant follows the MTS production strategy in which the produced wafers are pushed into the ADI, the place where AWIP are stored until orders for specific product from downstream assembly and distribution pull/push them depending on its availability. While A_G depletes AWIP, D_I replenishes it. D_I , measured in die per month, depends on F_G (wafers per month), adjusted by DPW and Y_D , i.e. the fraction of good die per wafer and Y_L to indicate the fraction of the good fabricated wafers. For simplicity, a first order delay is utilized for modelling process. While F_G depletes FWIP, WS^* replenishes it. The fab managers determine WS^* based on gross WS and $FWIP_{ADJ}$. The former is determined by D^* required by assembly/test plants, which is based on a long-term demand forecast (ED) and an adjustment from AWIP, while $FWIP_{ADJ}$ depends on discrepancies between $FWIP^*$ and $FWIP$ adjusted by T_{FWIP} . The capacity utilization (CU) is set based on ratio between WS^* and available capacity (K) operating at the normal capacity utilization level ($CU_N=90\%$). The remaining 10% spare capacity is utilized for engineering purpose and to deal with manufacturing instability. For a given D , K is determined by: $K = \frac{D \cdot MS}{CU_N \cdot DPW \cdot Y_D \cdot Y_L}$, where MS (market share) is not considered in this study. When WS^* is larger than normal capacity utilization, Fab managers try to increase CU_N and thus the spare capacity for engineering is reduced. On the other hand, When WS^* falls below the normal CU_N , capacity utilization will vary enough to exactly match WS^* . However, field study (Gonçalves, Hines, and Sterman 2005) showed that the managers prefer to build inventory by keeping Fab running even when WS^* falls below the normal capacity utilization. As the result, WS^* can be fully met by adjusting capacity utilization level and Fab managers prefer the ‘Lean-based’ production to avoid machine shut down for the low capacity utilization scenario.

Based on this empirical information, we can separate the Intel supply chains into three distinctive scenarios as follows:

- *Fabrication MTS + Assembly MTO + Distribution MTO mode.* Such a system is highly desired since the customers’ orders can be fulfilled immediately by FGI (sufficient on-hand FGI and AWIP inventory). The only waiting time for customers is the delivery delay, which is assumed to be a first-order delay.
- *Fabrication MTS + Assembly MTO + Distribution MTS mode.* If FGI is insufficient for customers’ orders, Intel can only ship what is feasible (S_{MAX}) and transfer the backlog/inventory signal into the assembly process to raise the assembly rate. In such a condition, the assembly system still operates the MTO mode under the premise that there are sufficient AWIP. The lead time for backlogged orders is increased to the summation of the delivery delay and assembly delay.
- *Fabrication MTS + Assembly MTS + Distribution MTS mode.* If the assembly is also constrained by the feasible AWIP level, the whole supply chain system will switch to a

pure MTS mode. The customer orders cannot be fulfilled for a short time, due to the long delay in fabrication production, and the lead time for backlogged orders is increased to the summation of the *delivery delay, assembly delay and fabrication delay*.

It can be concluded that the Intel supply chain is a typical multi-product, multi-level production environment where the final processors are produced through a series of sequences, from fabrication to assembly and final shipments processing. Customer demand ultimately determines the microprocessors' production, and the whole supply chain system operates as a hybrid MTS-MTO in which the actual shipment and assembly completions are driven by incoming demand orders, while the upstream wafer production is influenced by long-term demand forecasting. However, the MTO part will automatically switch to an MTS mode if there is no feasible AWIP/FGI in the assembly or distribution system, and customers will experience the corresponding delay increase due to the switch from MTO to MTS.

3.2 Extracting the hybrid MTS-MTO supply chain

Based on the causal loop diagram of Figure 2, and the detailed model description in Section 3.1, we developed the Intel supply chain model in a block diagram form, using continuous time domain, Laplace s , as shown in Figure 3. In a recent publication, Naim et al. (2017) accomplished the same resulting block diagram but in discrete time.

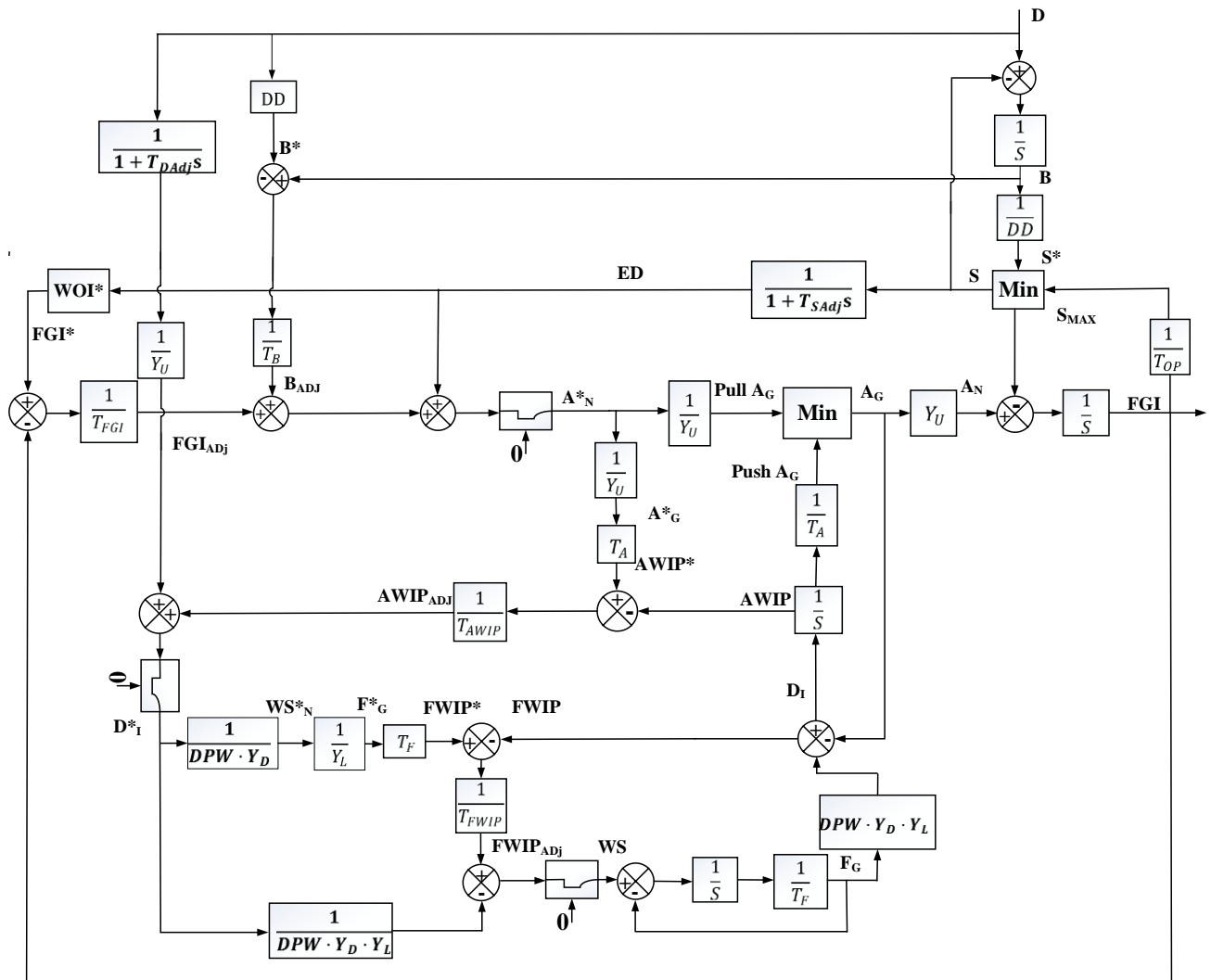

Figure 3. Block diagram representation of the Intel supply chain

To analytically explore the underlying dynamic behaviour of the hybrid MTS-MTO semiconductor supply chain systems, we simplify the block diagram through the following procedures, following Wikner, Naim, and Towill (1992):

1. Transfer non-negative components into linear approximations.

Eliminating three non-negative nonlinear constraints by assuming the relevant variables are never negative. Thus, non-negative constraints that restrict D^*_I , A^*_N , and WS are eliminated.

2. Supply chain echelon elimination

We assume that there is no distribution delay and that what is assembled into the FGI can be directly fulfilled by external customer demand, that is, the distribution echelon is eliminated. Thus, the backlog orders can be represented by negative FGI under the linear assumption of Step 1, and the switch between S^* and S_{MAX} is eliminated. The whole model now becomes a two-stage supply chain system.

3. Redundancies elimination

- a. Given the assumption that the shipment made is equal to the demand, that is, $S=D$, then $B = DD \cdot D$ and $B^* = DD^* \cdot D$ so that $B_{ADJ} = 0$
- b. $ED=ES$
- c. S_{MAX} is redundant, given Step 2.

4. Collecting terms

Gross WS^* is determined by the desired net wafer start rate adjusted by Y_L and in turn, the desired wafer production rate is determined by D^* in assembly, adjusted by the DPW and the die yield Y_D , so we have following relationship:

$$\text{Gross } WS^* = \frac{1}{DPW \cdot Y_D \cdot Y_L} D^*$$

To simplify the block diagram, we collect terms as follow:

- a. $K_1 = \frac{1}{DPW \cdot Y_D \cdot Y_L}$
- b. $K_2 = K_1 \cdot T_F$
- c. $K_3 = \frac{1}{K_1}$

Since the linear model shown in Figure 4 is now considerably simpler than the original complex supply chain, it can no longer be referred as the Intel supply chain, instead, the model is, from now on, termed as a semiconductor hybrid MTS-MTO supply chain. One benefit of investigating the linear system is that it enables the analytical tracing of supply chain dynamics. Given that, in reality, semiconductor manufacturing suffers high capacity unevenness (Karabuk and Wu 2003) due to reactive capacity adjustment driven by the dynamic behaviour, there is a need for managers to proactively control the supply chain dynamics, and, especially, the bullwhip effect, via understanding the root causes of such dynamic capacity requirements responses. This can be attained by assuming linearity and using well-established linear control techniques to explore the impact of major control policies on the dynamic behaviour. However, given that the simplification process and the linear assumptions necessary for the analytical investigation may impact on the accuracy of responses and on certain variable interactions, we will cross-check the analytical results (to be presented in Section 4) with numerical simulations of the nonlinear model (to be presented in Section 5) in order to enhance

is an instantaneous assembly process that has a zero-yield loss for what is required for assembly, due to the MTS-MTO condition that pull A_G is always larger than push A_G .

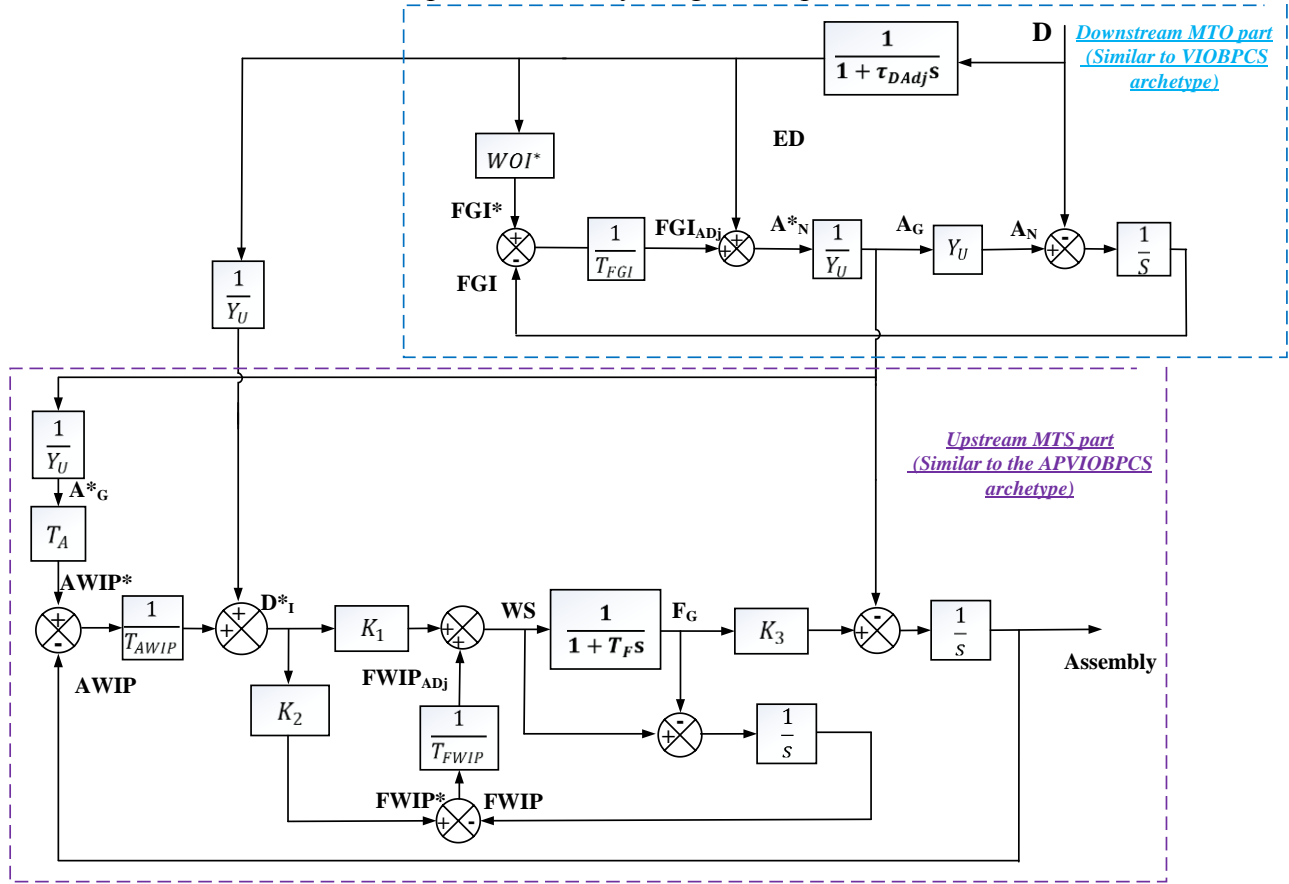

Figure 5. Simplified block diagram for a semiconductor hybrid MTS-MTO mode.

As such, the desired rate (ordering rate), A_N^* , equals the net assembly complete rate (A_N) as follows:

$$A_N^*(t) = FGI_{ADJ}(t) + ED(t) \quad (1)$$

Where

$$FGI_{ADJ}(t) = \frac{1}{T_{FGI}} \cdot (ED(t) \cdot WOI^* - FGI(t)) \quad (2)$$

and

$$ED(t) = ED(t-1) + a \cdot (D(t) - ED(t-1)) \quad \text{and} \quad a = \frac{1}{1 + \frac{T_{DAdj}}{\Delta T}} \quad (\text{Towill 1977}) \quad (3)$$

The upstream MTS fabrication system is similar to the APVIOBPCS replenishment rule that includes inventory feedback correction (AWIP), work-in-process feedback correction (FWIP) and feedforward forecasting compensation (ED). There are two inputs in such a system including demand from the MTO system and the end customer, and feedforward forecasting, i.e. $ED(t)$, is based on the end customer demand (D). Therefore, the ordering rate for each replenishment cycle is given by:

$$WS(t) = \frac{K_1}{Y_U} \cdot ED(t) + K_1 \cdot AWIP_{ADJ}(t) + FWIP_{ADJ}(t) \quad (4)$$

and $AWIP_{ADJ}(t)$ is determined by the fraction of difference between the desired assembly pull level and actual AWIP level, which equals:

$$AWIP_{ADJ}(t) = \frac{1}{T_{AWIP}} \cdot \left(A_N^*(t) \cdot \frac{T_A}{Y_U} - AWIP(t) \right) \quad (5)$$

$FWIP_{ADJ}(t)$ is determined by a fraction of the difference between the desired inflow FWIP and the actual FWIP as follows:

$$FWIP_{ADJ}(t) = \frac{1}{T_{FWIP}} \cdot \left(T_F \cdot K_1 \cdot \left(ED(t) \cdot \frac{1}{Y_U} + AWIP_{ADJ}(t) \right) - FWIP(t) \right) \quad (6)$$

It should be noted that the safety stock levels, AWIP and FGI*, and desired FWIP* are based on constant gains, WOI^* , T_A and K_2/Y_U , that need to be set. Hence, there is an opportunity to further explore the impact of setting such levels, which give more insight on the overall dynamic behaviour of the hybrid MTS-MTO system. e.g. see Manary and Willems (2008) method to address the issue of systematically biased forecast experienced by the Intel supply chain. However, it is beyond the scope of this paper to investigate the impact of parameter variation on the dynamics of the hybrid MTS-MTO semiconductor supply chain.

In order to allow us to benchmark the dynamic behaviour of the upstream MTS representation with an exact APVIOBPCS, we redraw the block diagram in Figure 5 to represent the exact APVIOBPCS system as shown in Figure 6.

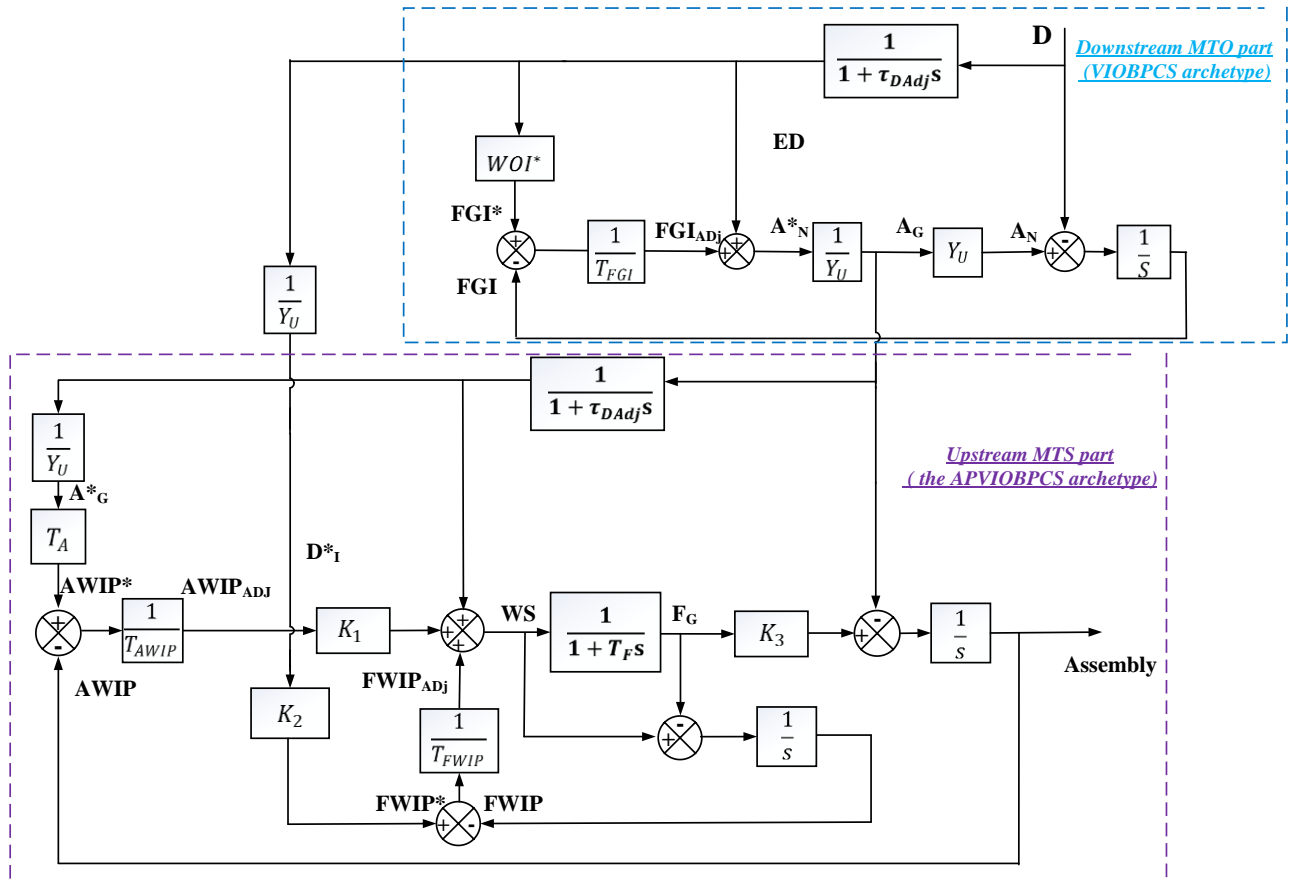

Figure 6. The APVIOBPCS-based hybrid MTO-MTS in block diagram form

From Figures 5 and 6, we may observe that, unlike the traditional APVIOBPCS ordering rule that has only one input, i.e. demand from the MTO system, there are two inputs utilized for the wafer production rate in the semiconductor MTS system: 1) demand from the next-level supply chain echelon;

and 2) demand from the end customer order. Such a structure is, fundamentally, a material requirement planning (MRP) system, while the APVIOBPCS has been defined as a ‘Reorder system’ (Popplewell and Bonney 1987). Table 3 summarizes the difference between the two ordering rules for the MTS system.

<i>Type of system (the MTS)</i>	<i>Targeted Inventory (feedback loop)</i>	<i>Targeted WIP (feedback loop)</i>	<i>Feedforward forecasting loop</i>
Semiconductor MRP system	As a function of demand from the ordering rate at assembly production (A_N^*)	As a function of the summation of inventory correction (AWIP) and demand from end customer (D)	Based on final customer demand (D)
Reorder system (APVIOBPCS)	As a function of demand from the ordering rate at assembly production (A_N^*)	As a function of demand from the ordering rate at assembly production (A_N^*)	Based on demand from the ordering rate at assembly production (A_N^*)

Table 3. The comparison of system structure between the semiconductor MRP and APVIOBPCS systems.

In summary, the final stylised hybrid MTS-MTO structure consists of two major ordering rules under the assumption that the CODP inventory are always available for end customers’ orders. Downstream of the CODP is the VIOBPCS ordering rule with negligible lead time; while the upstream MTS structure is similar to the APVIOBPCS, but there are some differences regarding the settings of the targeted WIP feedback loop as well as the feedforward forecasting loop. Using a control engineering approach, we now investigate the underlying dynamic behaviour of the semiconductor hybrid supply chain system.

4.2 Transfer function analysis

As we focus on the dynamic behaviour of the inventory and order rate in responding to the external demand signal under the hybrid MTS-MTO supply chains (Figure 5), the corresponding transfer functions, downstream FGI, A_N^* in relation to the demand (D), can be derived based on the following procedures:

- Substitute Equation (2) into (1);
- Substitute Laplace domain of ED in relation to D, i.e. $ED = D \cdot \frac{1}{1+T_{DAAdj}s}$, into Equation (1);
- Substitute Laplace domain of FGI in relation to A_N^* , i.e. $= (A_N^* - D) \cdot \frac{1}{s}$, into Equation (2) and then Substitute Equation (2) into (1).

We now have the transfer function of A_N^* in relation to D:

$$\frac{A_N^*}{D} = \frac{1 + (T_{DAAdj} + T_{FGI} + WOI^*)s}{1 + (T_{DAAdj} + T_{FGI})s + T_{DAAdj}T_{FGI}s^2} \quad (7)$$

Substitute Equation (7) into $FGI = (A_N^* - D) \cdot \frac{1}{s}$, the transfer function of FGI can be derived thus:

$$\frac{FGI}{D} = \frac{WOI^* - T_{DAAdj}T_{FGI}s}{1 + (T_{DAAdj} + T_{FGI})s + T_{DAAdj}T_{FGI}s^2} \quad (8)$$

Similarly, the upstream WS and AWIP in relation to D can be derived by the following steps:

- Substitute Equation (5) and (6) into (4) in Laplace form to obtain:

$$WS = \frac{K_1}{Y_U} \cdot ED + K_1 \cdot \frac{1}{T_{AWIP}} \left(A_N^* \cdot \frac{T_A}{Y_U} - AWIP \right) + \frac{1}{T_{FWIP}} \cdot \left(T_F \cdot K_1 \cdot \left(ED \cdot \frac{1}{Y_U} + \frac{1}{T_{AWIP}} \cdot \left(A_N^* \cdot \frac{T_A}{Y_U} - AWIP \right) \right) - FWIP \right) \quad (9)$$

Where

$$FWIP = (WS - F_G) \cdot \frac{1}{S} = WS \cdot \frac{T_F}{1 + T_F S} \quad (10)$$

$$AWIP = (F_G - A_N^*) \cdot \frac{1}{S} = \left(WS \cdot \frac{1}{1 + T_F S} - A_N^* \right) \cdot \frac{1}{S} \quad (11)$$

$$ED = D \cdot \frac{1}{1 + T_{DAdj} S} \quad (12)$$

- Substitute Equation (7), (10), (11) and (12) into (9)

Now we can obtain the transfer function of WS in relation to D as follows:

$$\begin{aligned} \frac{WS}{D} = \frac{K_1}{Y_U} \cdot \frac{ & (T_F + T_{FWIP}) + \\ & \left(\begin{array}{l} WOI^* T_F + T_{DAdj} T_F + T_A T_F + T_{AWIP} T_F + T_F^2 + T_F T_{FGI} + WOI^* T_{FWIP} + \\ T_{DAdj} T_{FWIP} + T_A T_{FWIP} + T_{AWIP} T_{FWIP} + T_F T_{FWIP} + T_{FGI} T_{FWIP} \end{array} \right) S + \\ & \left(\begin{array}{l} T_{AWIP} T_F^2 + T_A T_F T_{FGI} + T_{AWIP} T_F T_{FGI} + T_F^2 T_{FGI} + WOI^* T_A T_{FWIP} + \\ T_{DAdj} T_A T_{FWIP} + WOI^* T_F T_{FWIP} + T_{DAdj} T_F T_{FWIP} + \\ T_A T_F T_{FWIP} + T_{AWIP} T_F T_{FWIP} + \\ T_A T_{FGI} T_{FWIP} + T_{AWIP} T_{FGI} T_{FWIP} + T_F T_{FGI} T_{FWIP} \end{array} \right) S^2 + \\ & \left(\begin{array}{l} WOI^* T_A T_F^2 + T_{DAdj} T_A T_F^2 + T_A T_F^2 T_{FGI} + T_{AWIP} T_F^2 T_{FGI} + WOI^* T_A T_F T_{FWIP} + \\ T_{DAdj} T_A T_F T_{FWIP} + T_A T_F T_{FGI} T_{FWIP} + T_{AWIP} T_F T_{FGI} T_{FWIP} \end{array} \right) S^3 \\ & \left(\begin{array}{l} (T_F + T_{FWIP}) + \left(\begin{array}{l} T_{DAdj} T_F + T_{AWIP} T_F + T_F T_{FGI} + \\ T_{DAdj} T_{FWIP} + T_{AWIP} T_{FWIP} + T_{FGI} T_{FWIP} \end{array} \right) S + \\ \left(\begin{array}{l} T_{DAdj} T_{AWIP} T_F + T_{DAdj} T_F T_{FGI} + T_{AWIP} T_F T_{FGI} + T_{DAdj} T_{AWIP} T_{FWIP} + \\ T_{AWIP} T_F T_{FWIP} + T_{DAdj} T_{FGI} T_{FWIP} + T_{AWIP} T_{FGI} T_{FWIP} \end{array} \right) S^2 + \\ \left(\begin{array}{l} T_{DAdj} T_{AWIP} T_F T_{FGI} + T_{DAdj} T_{AWIP} T_F T_{FWIP} + \\ T_{DAdj} T_{AWIP} T_{FGI} T_{FWIP} + T_{AWIP} T_F T_{FGI} T_{FWIP} \end{array} \right) S^3 + \\ T_{DAdj} T_{AWIP} T_F T_{FGI} T_{FWIP} S^4 \end{array} \right) \end{aligned} \quad (13)$$

Substitute Equation (7) and (13) into (11), we can obtain the transfer function of AWIP in relation to D:

$$\begin{aligned} \frac{AWIP}{D} = \frac{1}{Y_U} \cdot \frac{ & (T_A T_F + T_A T_{FWIP}) + \\ & \left(\begin{array}{l} WOI^* T_A T_F + T_{DAdj} T_A T_F - WOI^* T_{AWIP} T_F - T_{DAdj} T_{AWIP} T_F + T_A T_F T_{FGI} + \\ WOI^* T_A T_{FWIP} + T_{DAdj} T_A T_{FWIP} - WOI^* T_{AWIP} T_{FWIP} - \\ T_{DAdj} T_{AWIP} T_{FWIP} - T_{AWIP} T_F T_{FWIP} + T_A T_{FGI} T_{FWIP} \end{array} \right) S \\ & + \left(-WOI^* T_{AWIP} T_F T_{FWIP} - T_{DAdj} T_{AWIP} T_F T_{FWIP} - T_{AWIP} T_F T_{FGI} T_{FWIP} \right) S^2 \\ & \left(\begin{array}{l} (T_F + T_{FWIP}) + \left(\begin{array}{l} T_{DAdj} T_F + T_{AWIP} T_F + T_F T_{FGI} + T_{DAdj} T_{FWIP} + \\ T_{AWIP} T_{FWIP} + T_{FGI} T_{FWIP} \end{array} \right) S + \\ \left(\begin{array}{l} T_{DAdj} T_{AWIP} T_F + T_{DAdj} T_F T_{FGI} + T_{AWIP} T_F T_{FGI} + T_{DAdj} T_{AWIP} T_{FWIP} + \\ T_{AWIP} T_F T_{FWIP} + T_{DAdj} T_{FGI} T_{FWIP} + T_{AWIP} T_{FGI} T_{FWIP} \end{array} \right) S^2 + \\ \left(\begin{array}{l} T_{DAdj} T_{AWIP} T_F T_{FGI} + T_{DAdj} T_{AWIP} T_F T_{FWIP} + \\ T_{DAdj} T_{AWIP} T_{FGI} T_{FWIP} + T_{AWIP} T_F T_{FGI} T_{FWIP} \end{array} \right) S^3 + \\ T_{DAdj} T_{AWIP} T_F T_{FGI} T_{FWIP} S^4 \end{array} \right) \end{aligned} \quad (14)$$

The transfer function represents the dynamic properties of the system. In particular, the characteristic equation, defined by equating the denominator of overall transfer function to zero, can be used to find poles (roots), which give an initial understanding of the underlying dynamic mechanism of the semiconductor hybrid MTS-MTO system including *system stability* and *unforced system*

dynamic property (i.e. natural frequency and damping ratio). Stability is a fundamental property of a supply chain system. From the linear system perspective, the system is stable if the trajectory will eventually return to an equilibrium point irrelevant to the initial condition, while an infinity trajectory is presented if the system is unstable (Wang, Disney, and Wang 2012). Thus, the system response to any change in an input (demand) will result in uncontrollably increasing oscillations in the supply chain (Disney and Towill 2002). A system also has critical stability when it is located at the edge of the stability boundary, and system oscillations are regular and infinite for such situation. More details of supply chain stability can be found in Riddalls and Bennett (2002), Warburton et al. (2004), Sipahi and Delice (2010). Regarding the unforced system dynamic property, natural frequency (ω_n) determines how fast the system oscillates during the transient response and can be used to indicate the system's speed to reach the steady state condition for responding external demand signal, e.g. the inventory recovery speed. Damping ratio (ζ), on the other hand, describes how the system's oscillatory behaviour (i.e. variability) decays with time, and can be perceived as initial insight of the system's unforced dynamic performance; for instance, the extent to which the order rate and inventory will oscillate with time.

We now focus on the characteristics equations. By rewriting the denominator of Equation (7), (8), (13) and (14) as Equation (15), it can be seen that the MTO is characterized by a second-order system, while a fourth-order polynomial describes the MTS system:

$$(1 + T_{DAdj}s)(1 + T_{FGI}s) = 0$$

$$(1 + T_{DAdj}s)(1 + T_{FGI}s)(T_F + T_{FWIP} + (T_{AWIP}T_F + T_{AWIP}T_{FWIP})s + T_{AWIP}T_FT_{FWIP}s^2) = 0 \quad (15)$$

Also, there is a second-order polynomial, $(1 + T_{DAdj}s)(1 + T_{FGI}s)$, in the denominator of all transfer functions, which confirms that the dynamic property of the MTO system is not influenced by the MTS system, while the dynamic performance of the MTS system can be partially manipulated by the MTO system under the hybrid MTS-MTO mode.

We now turn to the analysis of Initial Value Theorem (IVT) and Final Value Theorem (FVT). The IVT is a useful tool to cross-check mathematically the correctness of a transfer function and guide the appropriate initial condition required by a simulation. The FVT is useful to understand the steady state value of the dynamic response of a transfer function and can help verify the simulation. Equation 16 presents the initial and final values of FGI, A_N^* , WS and AWIP in responding to a unit step input for the semiconductor hybrid MTS-MTO system.

$$\begin{aligned} \lim_{s \rightarrow \infty} s \frac{A_N}{D} &= 0 & \lim_{s \rightarrow 0} s \frac{A_N}{D} &= 1 \\ \lim_{s \rightarrow \infty} s \frac{FGI}{D} &= 0 & \lim_{s \rightarrow 0} s \frac{FGI}{D} &= WOI \\ \lim_{s \rightarrow \infty} s \frac{WS}{D} &= 0 & \lim_{s \rightarrow 0} s \frac{WS}{D} &= \frac{K_1}{Y_U} \\ \lim_{s \rightarrow \infty} s \frac{AWIP}{D} &= 0 & \lim_{s \rightarrow 0} s \frac{AWIP}{D} &= \frac{T_A}{Y_U} \end{aligned} \quad (16)$$

As expected, the initial values of FGI, A_N^* , AWIP, FWIP and WS are zero; similar to the results obtained by John, Naim and Towill (1994). Regarding the final value, the ordering rate (A_N^*) of the MTO system is unity and the steady state level of the FGI is WOI^* as it is a function of the averaged demand. The final value of ordering rate (WS) for the upstream MTS system is, as expected, a system constant value K_1/Y_U , and the final value of AWIP is determined by the coefficient T_A (the targeted inventory level in the APVIOBPCS). Since the downstream MTO system is not influenced by the upstream MTS system, due to the assumption of infinite AWIP availability to maintain the MTO assembly while the dynamic behaviour of MTS is influenced by the upstream MTO, we analyse the

dynamic properties of the MTO and MTS systems separately.

4.3 Characteristic equation analysis of the MTO system

Since the transfer function of the MTO part is a second-order system, its associated dynamic properties are defined by ω_n and ζ , determined by the characteristic equation. Hence, we obtain ω_n and ζ as follows:

$$\omega_n = \sqrt{\frac{1}{T_{DAdj}T_{FGI}}} \quad \zeta = (T_{DAdj}+T_{FGI}) \sqrt{\frac{1}{2 T_{DAdj}T_{FGI}}} \quad (17)$$

Based on Equation 17, both ω_n and ζ are determined by the control parameters T_{DAdj} and T_{FGI} . The natural frequency decreases as the values of T_{DAdj} and T_{FGI} increase, leading to a slower dynamic response and recovery to the steady state conditions for the MTO system. To visualize the relationship between ζ and T_{DAdj} and T_{FGI} , we rewrite Equation 17 as 18:

$$\zeta = \sqrt{\frac{1}{2} \left(\frac{T_{DAdj}}{T_{FGI}} + \frac{T_{FGI}}{T_{DAdj}} \right) + 1} \quad (18)$$

When $T_{DAdj} = T_{FGI}$, ζ always assumes the same value ($\sqrt{2}$). When either T_{DAdj} or T_{FGI} increases, ζ increases further, decreasing the number of oscillations in responding to external demand but making the system slow. The important message here is that $\zeta \geq 1$ for all positive values of T_{DAdj} and T_{FGI} , which means that the system always produces over-damped behaviour and is guaranteed to be stable. This is important because the system is permitted to be stable and robust for any choice of positive decision-making parameters. Furthermore, we cannot achieve both objectives of the rapid inventory recovery (natural frequency) and low level of bullwhip (i.e. maximum overshoot) determined by the damping ratio. This trade-off has also been confirmed mathematically by Towill (1982).

4.4. Unit step response of the MTO system

The unit step input is utilized to assess the dynamic behaviour of the semiconductor hybrid MTS-MTO system. The step as an input source is well documented (Towill 1970) in general control theory for exploring the system's capacity to respond to sudden but sustained change. Moreover, step change as the input is easily visualized and its response can be easily interpreted (John, Naim, and Towill 1994). Furthermore, the step increases give rich information for the dynamic behaviour of the system (Coyle 1977). From the supply chain point of view, the step demand can be regarded as the early stage of a new product or the opening of a new sales outlet (Zhou and Disney 2006), which fits the customer demand condition in the semiconductor industry characterized by a short life cycle with a corresponding sudden change in demand during the release of new products.

Due to the analogy between the VIOBPCS and the MTS mode of the semiconductor hybrid supply chain system, the set of parameters utilized is as suggested by Edghill and Towill (1990) with 4 units of assembly lead time ($T_A=4$). Based on the transfer functions of the MTO system, i.e. Equations (11) and (12), the value of required system parameters for simulation are thereby (weeks):

$$T_{DAdj}=8, T_{FGI}=4 \text{ and } WOI^*=5$$

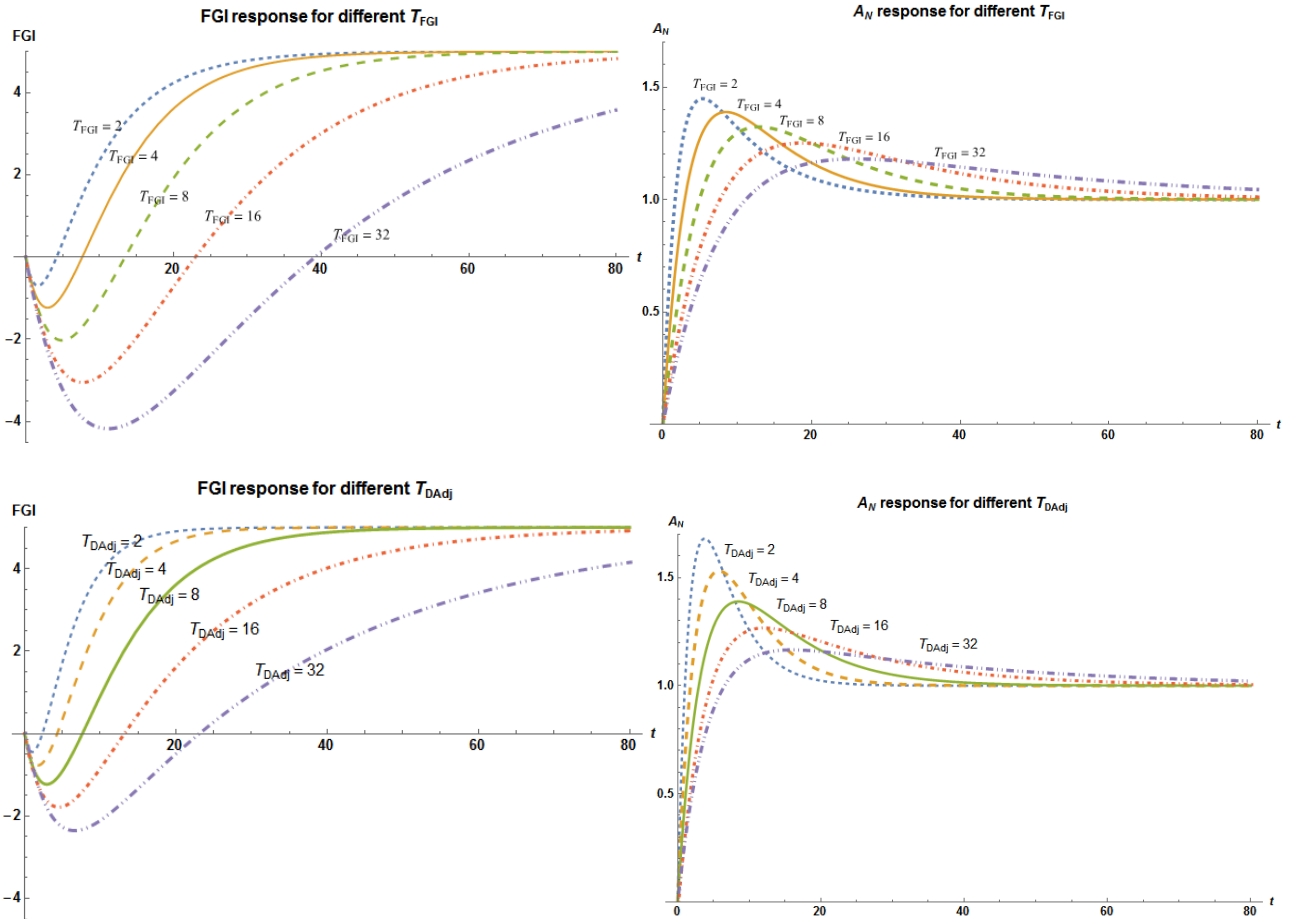

Figure 7. The impact of T_{DAdj} and T_{FGI} for FGI and A_N unit response.

Figure 7 demonstrates the impact of T_{DAdj} and T_{FGI} for the unit step response of the FGI and A_N . The solid line represents the recommended settings utilized in the VIOBPCS archetype. There is always an initial drop for the FGI response due to the transient response of a unit step increase in demand, and the absolute FGI drop value can thereby be utilized for setting initial stock levels to maintain supply to the MTO system. When T_{FGI} increases, the FGI response experiences a larger initial drop with a longer setting time, while the A_N has a shorter setting time at the expense of higher peak level. Similarly, a larger undershot and longer recovery time of the FGI response are observed when the value of T_{DAdj} increases, while the A_N experiences less bullwhip at the expense of a longer settling time.

To summarise, the downstream MTO assembly system always produces over-damped dynamic behaviour and such a system is guaranteed to be stable and robust, although there is an overshoot for A_N transient response due to the effect of the numerator of transfer functions. Bullwhip results from T_{DAdj} and T_{FGI} , which confirms the fact that forecasting (Dejonckheere et al. 2002) and feedback loops (Lee, Padmanabhan, and Whang 1997) are the major sources of bullwhip generation, even when the lead time is negligible. In particular, T_{DAdj} places a major emphasis on the bullwhip level, while T_{FGI} has a major impact on the FGI variance. This result also provides evidence that bullwhip is mainly caused by the feedforward compensation, instead of the feedback loop/production delay usually suggested. Although this phase advance/predictive component (Truxal and Weinberg 1955) in the hardware control engineering field has the advantage of ordering in advance to ensure stock availability, some solutions such as more sophisticated forecasting algorithms (Dejonckheere et al. 2002) must be implemented to reduce the bullwhip level.

4.5 Characteristic equations analysis of the MTS system

Based on Equations (15), the MTS system is characterized as a fourth-order polynomial that

can be rewritten as the product of two second-order polynomials. As the second-order polynomial, i.e. $(1 + T_{DAdj}S)(1 + T_{FGI}S)$, was already analysed in the MTO system, we derive the natural frequency and damping ratio for the other second-order polynomial as follows:

$$\omega_n = \sqrt{\frac{1}{T_{AWIP}T_{FWIP}} + \frac{1}{T_{AWIP}T_F}} \quad \zeta = \frac{1}{2} \sqrt{\frac{T_{AWIP}}{T_F} + \frac{T_{AWIP}}{T_{FWIP}}} \quad (19)$$

For a fixed T_F (physical fabrication lead time), ω_n and ζ are determined by T_{AWIP} and T_{FWIP} . The system response will become slower (smaller value of ω_n) as T_{AWIP} and T_{FWIP} increase. However, T_{AWIP} and T_{FWIP} have a reverse impact on ζ . The system will be more oscillatory as T_{FWIP} increases or T_{AWIP} decreases. It should be noted that T_{AWIP} has a major influence on the damping ratio compared to T_{FWIP} , which means the CODP inventory policy plays a major role in the system's dynamic behaviour.

To further understand the dynamic properties of the MTS system, including transient response and stability, we derive the four poles based on Equation (15) as follows:

$$R_1 = -\frac{1}{T_{FGI}}, \quad R_2 = -\frac{1}{T_{DAdj}}$$

$$R_3 = R_4 = \frac{-T_{AWIP}T_F - T_{AWIP}T_{FWIP} \pm \sqrt{T_{AWIP}\sqrt{T_F + T_{FWIP}}\sqrt{T_{AWIP}T_F + T_{AWIP}T_{FWIP} - 4T_FT_{FWIP}}}{2T_{AWIP}T_FT_{FWIP}} \quad (20)$$

There is no imaginary part for the roots of the first and second polynomials (R_1 and R_2), and thereby oscillatory behaviour cannot be generated. For R_3 and R_4 , the roots can be real, complex or purely imaginary and the real poles can also be positive, negative or repeated, influencing the transient response as well as the stability condition. We plot the different results of roots based on different fixed T_F values ranging from 1 unit to 4 units as shown in Figure 8.

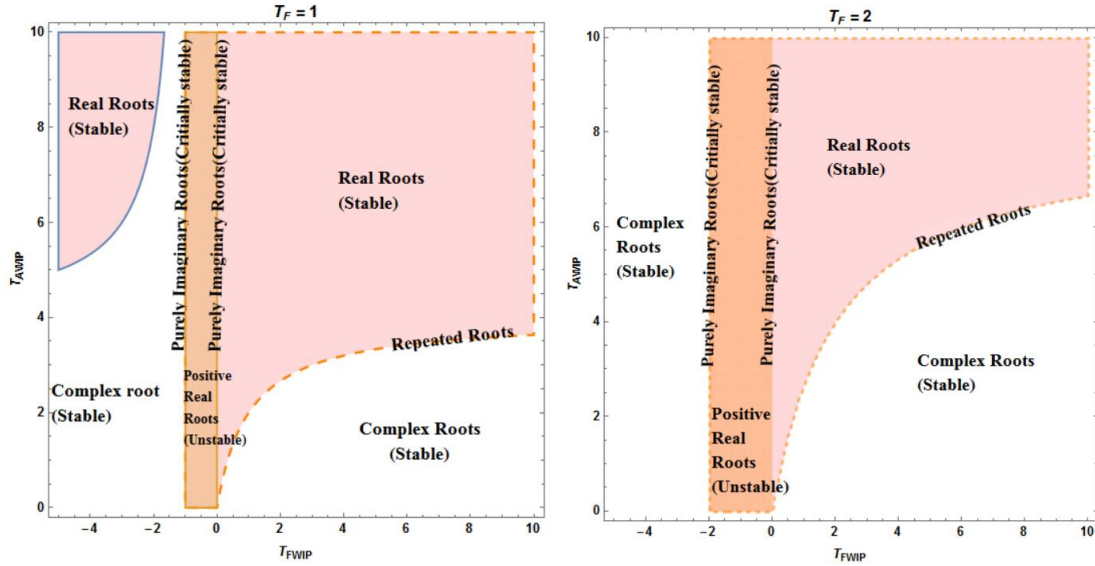

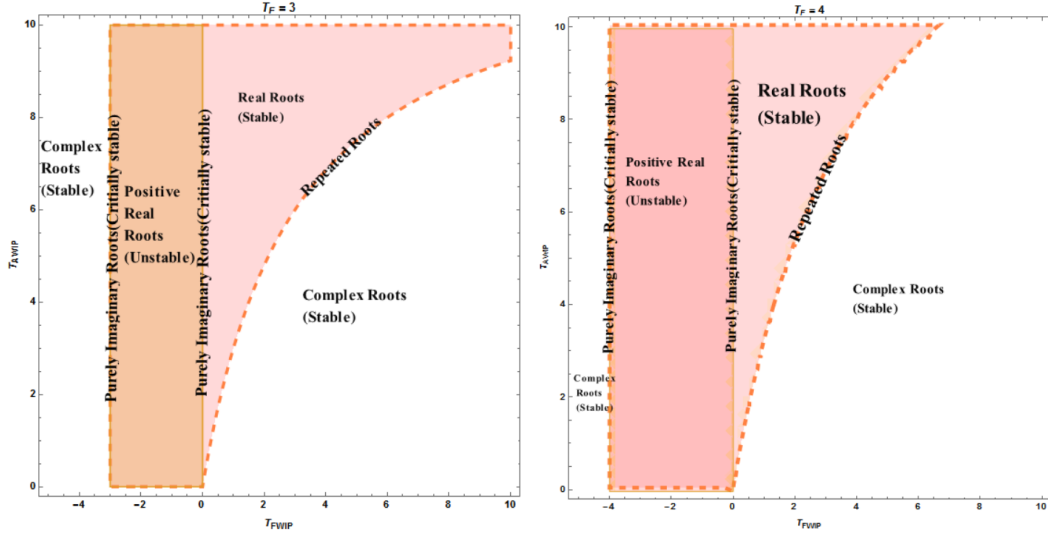

Figure 8. Real, complex and imaginary region of R_3 and R_4 based on different T_F .

Figure 8 illustrates that the roots are positive for the region between the line of purely imaginary roots and $T_{FWIP} = 0$, thus, the pair choice of T_{AWIP} and T_{FWIP} in this area will lead to an unstable system. Also, we consider the impact of negative FWIP feedback controller (T_{FWIP}) on the results of the roots, although, conventionally, it is assumed to be a positive value range. The negative T_{FWIP} has been investigated in the case of a uniformed and irrational replenishment rule design (Wang, Disney, and Wang 2012, 2014). Based on Figure 9, the roots will become purely imaginary if the real part of the roots is zero (i.e. $T_{FWIP} = -T_F$). Furthermore, the purely imaginary roots are the critically stable point; as such, the system response will be sustainably oscillatory.

Although the transient response of the fourth-order system is multifaceted, determined by the dominant pole(s) that is/are closest to the origin of the s plane, i.e. the combination of different control policies, the result in Figure 8 gives a qualitative understanding of the system's dynamic properties, i.e. whether stable or unstable, for different parameter choices. For instance, we can specify the range of T_{FWIP} and T_{AWIP} to generate real poles, i.e. a 'good' system dynamic design without generating oscillations. As a result, semiconductor companies may benefit from associated cost reduction by improved supply chain dynamics performance. In addition, the real poles region becomes smaller as fabrication lead time, T_F , increases, which means that the system is more likely to generate oscillatory behaviour based on different choices of decision parameter settings. Managers thus need to be aware that their upstream MTS systems are more likely to be oscillatory under their control policies if fabrication lead times become longer. Finally, we can conclude that such a semiconductor hybrid MTS-MTO system is stable for all positive decision parameter choices (T_{FWIP} , T_{AWIP} , T_{FGI} , T_{DAdj}).

4.6 Unit step response of the MTS system

To understand the impact of four system policies (T_{FWIP} , T_{AWIP} , T_{FGI} , T_{DAdj}) in influencing the transient response of the hybrid MTS-MTO system, we conduct a step response analysis through the initial settings suggested by John, Naim, and Towill (1994), i.e. $T_{AWIP} = T_{DAdj} = T_F$, $T_{FWIP} = 2T_F$ for the dynamic performance of the MTS system. The recommended settings of both VIOPCS and APVIOPCS will be utilized as the initial design to determine whether such parameter settings can still produce 'good' dynamic performance in the hybrid environment. The system's constant parameters including K_1 , K_2 , K_3 and Y_u will be discarded, as they do not influence the system's dynamic behaviour.

We assume that the lead time ratio between assembly and fabrication is 1:2 (i.e. 4 and 8 for assembly and fabrication) to represent the long-term upstream fabrication and relatively short time for the customized assembly. Thus, the initial setting is as follows (weeks):

$$T_F = 8, T_{AWIP} = 8, T_{FWIP} = 16$$

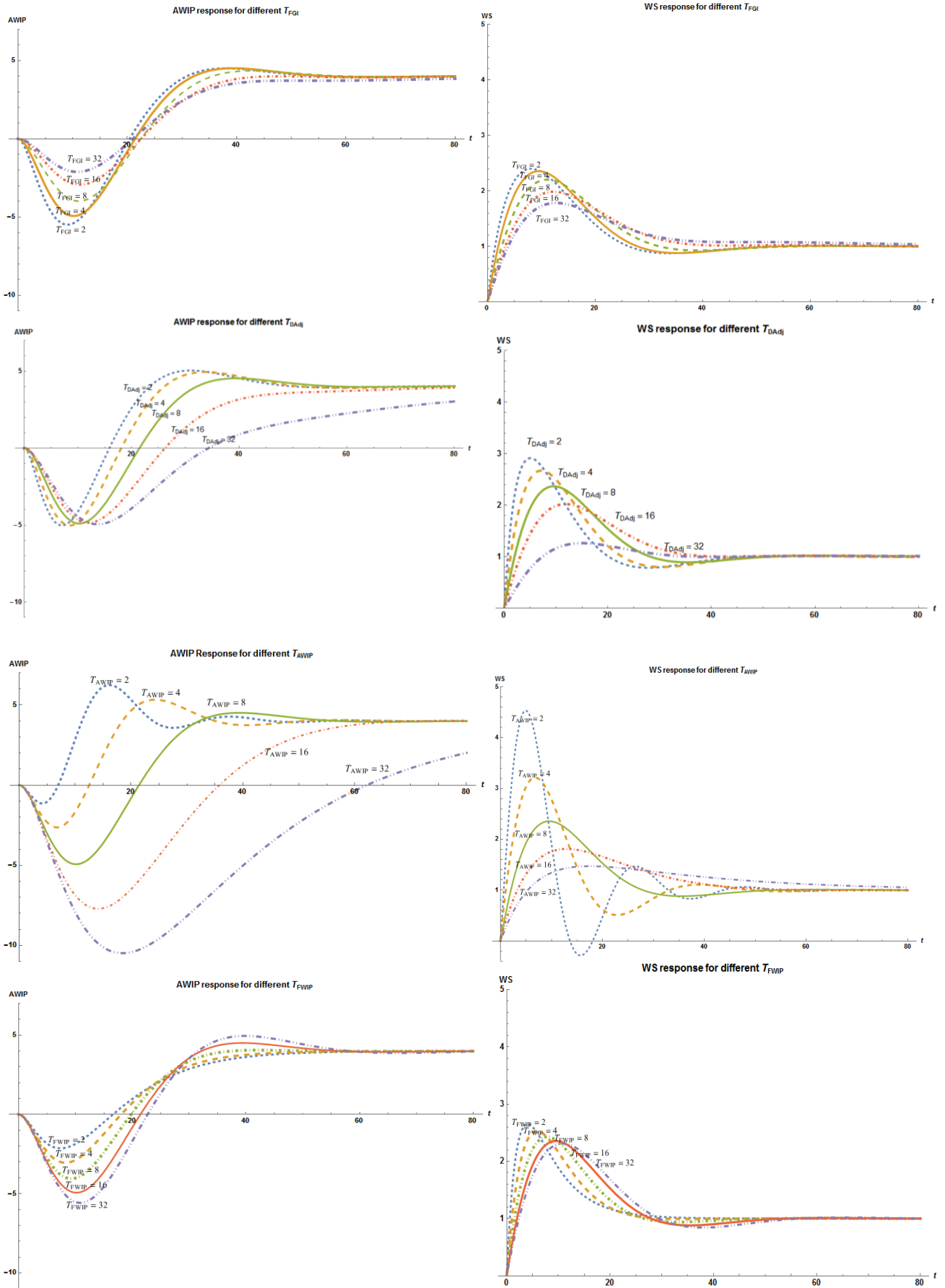

Figure 9. The effect of decision policies for the AWIP and WS in responding to unit step increases.

Figure 9 shows the impact of T_{FWIP} , T_{AWIP} , T_{FGI} and T_{DAadj} on the dynamic behaviour of the WS and AWIP in the MTS mode. The solid line represents the recommended settings used in the VIOBPCS and APIOBPCS archetypes. Compared to the downstream MTO mode, the bullwhip and inventory variance are more significant in the upstream MTS mode, due to the fact that the dynamic behaviour is amplified from the end customer to the far position of the entire supply chain (e.g. manufacturer). The AWIP always experiences an initial drop in responding to unit step input, as the AWIP must meet the downstream customer MTO signal during the transient period to maintain the hybrid MTS-MTO mode. The AWIP recovers to the desired level with a gradual increase in the fabrication production complete rate to match the unit step demand increase. The absolute decline level is helpful to indicate the safety inventory required to maintain the hybrid mode during the transient period.

Based on Figure 9 and Table 5, an increase in T_{DAadj} leads to a longer peak time and setting time, but less oscillation of the AWIP. Moreover, an increase in T_{DAadj} slightly reduces the peak level of the AWIP. It should be noted that the AWIP exhibits oscillatory behaviour for small values of T_{DAadj} in responding unit step increase, due to the long-term fabrication delay (T_F) and the amplified pull signal downstream (A_N) as the input of the MTS part. Similarly, the WS also experiences less bullwhip and fewer oscillations as T_{DAadj} increases at the expense of a longer setting time. Similarly, an increasing T_{FGI} reduces the overshoot and undershoot of the AWIP compromised by a slightly longer setting time. However, for a sufficiently long FGI correction time (large T_{FGI}), there is no system overshoot for the AWIP with a much shorter setting time. The WS experienced a high bullwhip level and more oscillation under small values of T_{FGI} .

Regarding the decision parameters in the upstream system, T_{AWIP} significantly influences the dynamic response of the AWIP and WS. An increase in T_{AWIP} dramatically increases the undershoot (also peak time) and setting time of the AWIP, while the WS has less bullwhip, oscillations and a shorter setting time. In particular, a small T_{AWIP} introduces extra oscillatory behaviour in response to the AWIP and WS, due to the feedback loop control and long production delay. An increase in T_{FWIP} damages the dynamic performance of the FWIP by producing more undershoot and oscillations with a longer setting time. Similarly, the WS response has more oscillations and a longer setting time at the expense of less bullwhip as T_{FWIP} increases. Since the target FWIP is the summation of ED and $AWIP_{ADJ}$ ($AWIP$ feedback loop has been included for $AWIP_{ADJ}$), the long correction time for the feedback FWIP loop will further amplify the effect of the $AWIP$ feedback loop by introducing extra dynamic behaviour for the AWIP and WS, which damaging their dynamic performance via introducing more oscillations. Furthermore, based on Figure 9 and Table 3, the recommended settings in the APIOBPCS and VIOBPCS can still be utilized in the hybrid MTS-MTO supply chain to yield a ‘good’ dynamic response when considering the trade-off between bullwhip and inventory recovery. We summarize four decision parameters’ impact on the hybrid MTS-MTO step response by increasing their value in Table 4:

Decision parameters	AWIP			WS			FGI			A_N		
	p	t_p	t_s	p	t_p	t_s	p	t_p	t_s	p	t_p	t_s
T_{sAdj}	0	↓	↓	↑	↓	↑	↓	↓	↓	↑	↓	↓
T_{FGI}	↑	↓	↑	↑	↓	↑	↓	↓	↓	↑	↓	↓
T_{AWIP}	↓	↓	↓	↑	↓	↑	0	0	0	0	0	0
T_{FWIP}	↓	↓	↑↓	↑	↓	↓	0	0	0	0	0	0

Table 4. Summary of the system response by increasing the value of decision parameters (p: peak level, t_p : time for peak level, t_s : setting time, ↑: better performance. ↓: worse performance, 0: no influence, ↑↓: from worse to better performance due to the extra oscillations).

It can be concluded that maintaining the hybrid MTO-MTS system in the semiconductor industry is highly desirable since customer orders can be fulfilled immediately. Feedforward

forecasting compensation and three feedback correction loops (FGI, AWIP, FWIP) have an impact on the bullwhip level. In particular, the CODP inventory policy (T_{AWIP}) and the forecasting policy (T_{DAdj}) significantly influence the bullwhip level; T_{AWIP} also plays a major role in the system's oscillatory behaviour. Thus, managers should carefully tune T_{AWIP} to balance the benefit between the cost of holding CODP inventory and the cost of supply chain dynamics. Moreover, practitioners should consider the choice of T_{FGI} to balance the levels of two safety stock points (AWIP and FGI), as such a policy has a reverse influence on the AWIP and FGI. Finally, the recommended settings in the APVIOBPCS and VIOBPCS are still 'good' in the semiconductor hybrid system, although there are some differences between the APVIOBPCS-based reorder system and the MRP-based replenishment rule. Furthermore, the dynamic response of A_N and WS, e.g. rising time, peak level and setting time, give useful guidance for benchmarking the results derived from the nonlinear dynamic system to set an optimal capacity in the nonlinear system, which may balance the cost of bullwhip and inventory variance in responding to a sudden but sustained change in demand.

5. Simulation enhancement

Although the analytical results derived from the linear system above offer deep insights into the system dynamic behaviour of a semiconductor MTS-MTO supply chain, linear assumptions are often criticized for being incapable of capturing nonlinear characteristics of the real supply chain system with resources constraints (e.g. capacity, non-negative order constrains) (Lin et al. 2016). To enhance the qualitative insights obtained from the linear analysis, we incorporate the nonlinearities to

represent the capacity, as a CLIP function ($\begin{matrix} [0, \text{Capacity limit}] \\ \text{CLIP} \end{matrix}$) and non-negativities in the hybrid MTS-MTO model of Figure 5. It should be noted that there are a number of other capacity forms that can be used to represent the capacitated semiconductor fabrication environment. e.g. see Orcun, Uzsoy and Kempf (2006)'s exploration of the dynamic behaviour of Clearing Function (CF) based capacity models in a simple capacitated production system.

The hybrid mode is still assumed to be in operation but in a resource constrained environment, reflected in the block diagram representation shown in Figure 10. We should note that the CLIP function is an addition that is not in the Gonçalves, Hines, and Sterman (2005)'s representation.

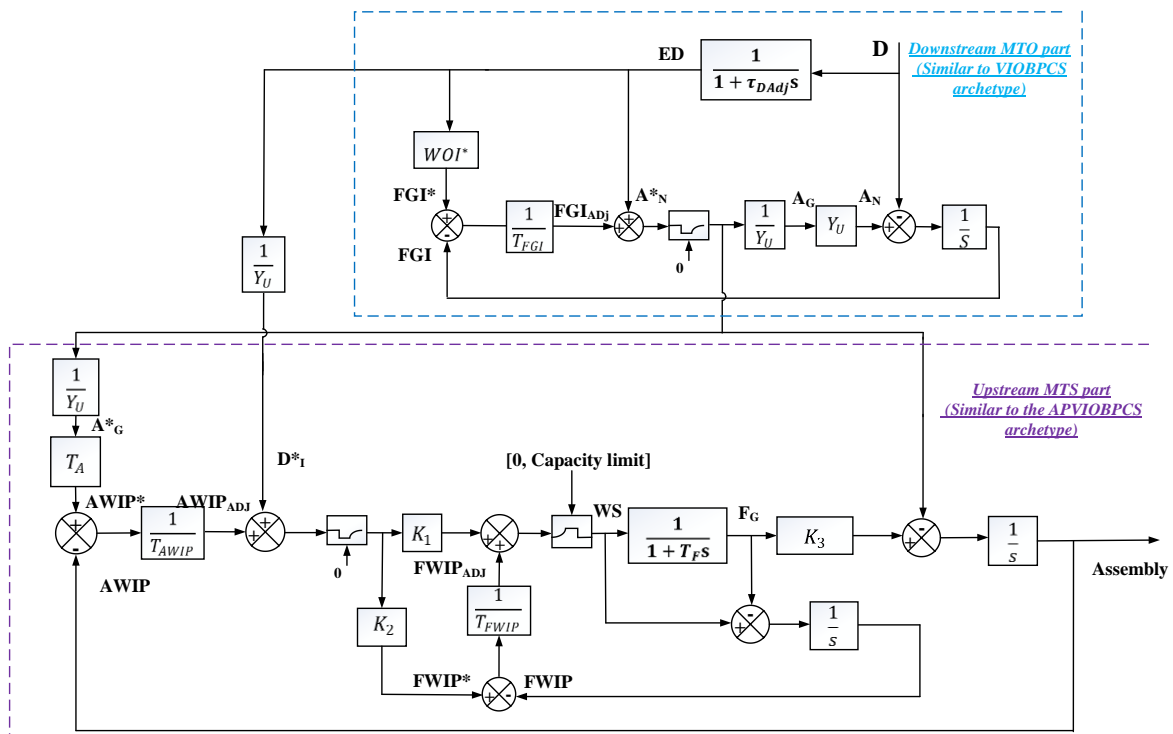
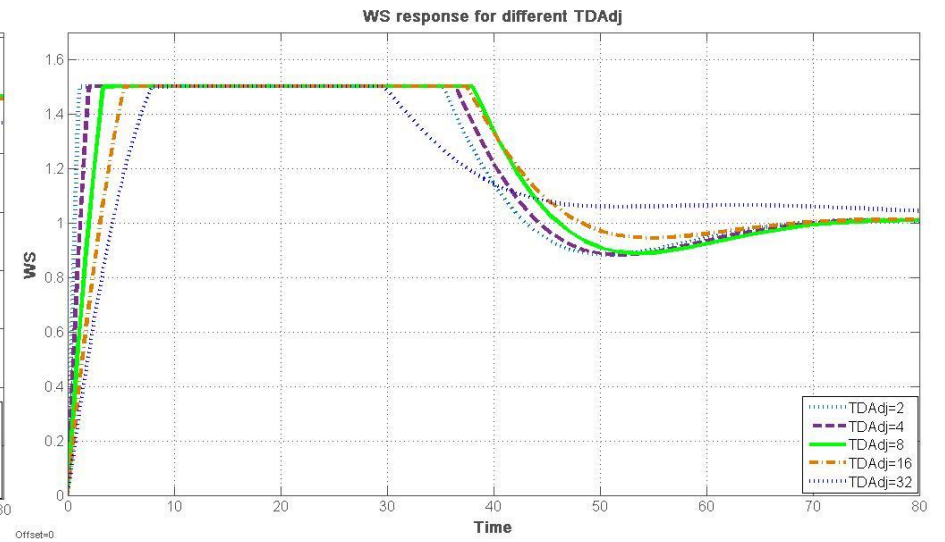
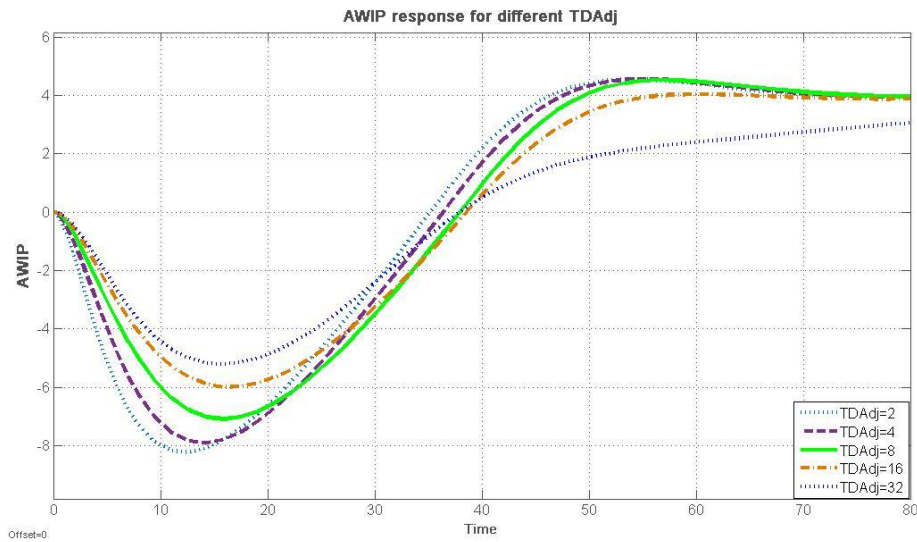
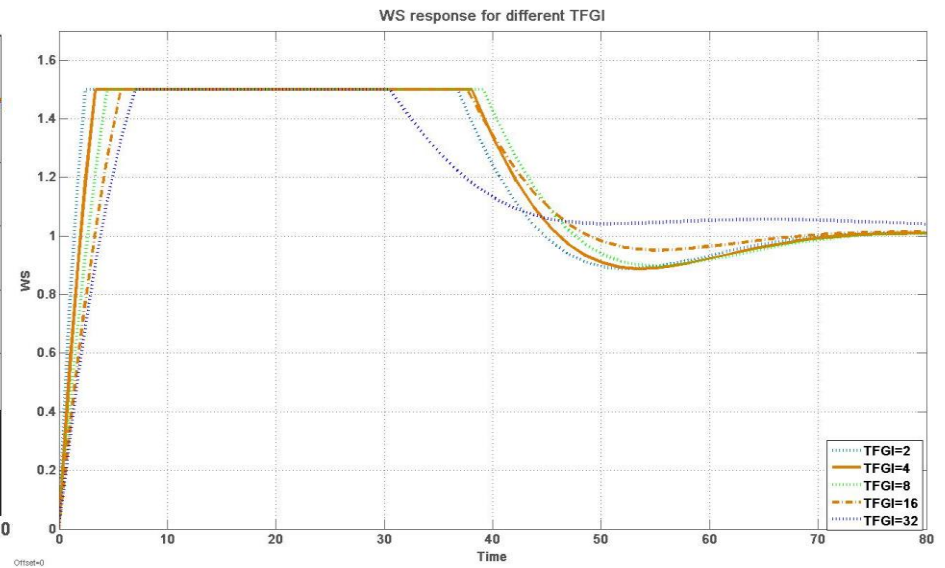
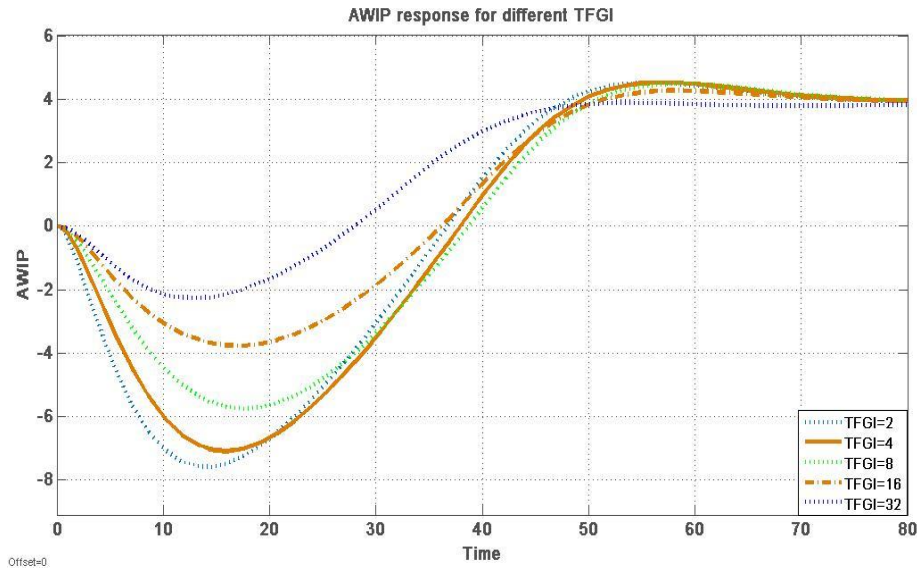

Figure 10. The semiconductor hybrid MTS-MTO supply chain in the nonlinear block diagram form.



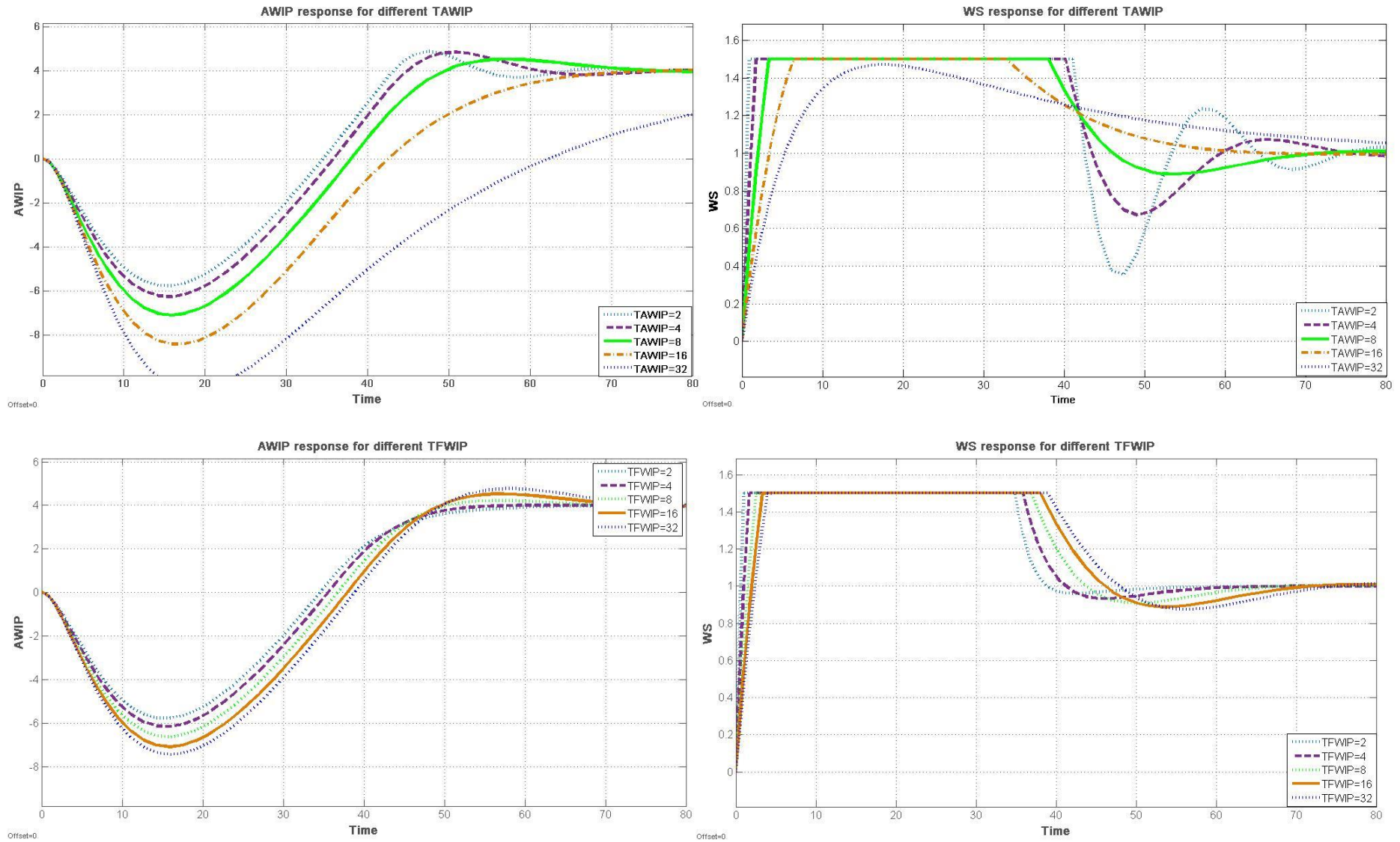

Figure 11. WS and AWIP response for a step demand increase in the nonlinear hybrid MTS-MTO settings

Similar to the linear system analysis, a step input is utilized and all system and control policies settings remain the same. Capacity limit in the MTS part is set as 50% larger than the step demand (i.e. 1.5), since on average manufacturing capacity has to be larger than required demand to keep the system stable. Figure 11 presents the impact of four system control policies (T_{DAj} , T_{FGI} , T_{AWIP} and T_{FWIP}) on the dynamic behaviour of the MTS part in the hybrid mode. The solid line represents the recommended settings in the original APVIOBPCS and VIOBPCS archetypes, although it is not necessary to be ‘optimal’ in the nonlinear environment depending on the specific trade-offs design between inventory and capacity. It should be noted that the corresponding control policies assessment for the MTO part independent of the MTS part is not reported here, due to the little dynamic impact of non-negative nonlinearity in responding to a step increase in demand, i.e. the same dynamic behaviour is observed in the nonlinear MTO system

In general, the simulation of a nonlinear hybrid MTS-MTO system shows that the insights obtained from the linearized analytical results are correct. The increase of policies in MTO part, i.e. T_{FGI} and T_{DAj} , negatively influences the dynamic performance of the CODP inventory (AWIP) by introducing more undershoot and longer setting time, while the better dynamic responses of WS are found with fewer oscillations and fast recovery speed. However, as expected, comparing the linear results (Figure 9) under the same control policy settings, the step increase in demand gives higher initial drop of AWIP and slower recovery speed of AWIP and WS in the nonlinear environment. This is because more CODP inventory (AWIP) is needed and longer recovery time is influenced by the period when the manufacturing rate hits the capacity limit. Furthermore, T_{AWIP} significantly influences the dynamic performance of the MTS part in the nonlinear hybrid system in terms of oscillations and recovery speed. The WIP correction policy in the MTS part, that is T_{FWIP} , as expected, reported the same qualitative insights obtained from the linear system in which an increase in T_{FWIP} lead to the worse dynamic behaviour of AWIP and WS by introducing more undershoot and oscillations. The whole hybrid MTS-MTO system experiences a significant reduction of bullwhip level (WS) at the expense of more AWIP variability in a capacitated based nonlinear system, in comparison with results obtained from the linear system.

6. Discussion and Conclusion

In this paper, we explored analytically the dynamic properties of a hybrid MTS-MTO supply chain system within the context of semiconductor industry. We used the supply chain model, empirically reported by Gonçalves, Hines, and Sterman (2005), as a benchmark model, to extract the MTS-MTO model and explore the underlying properties of such hybrid system in the semiconductor production environment. By utilizing control engineering techniques and the well-known IOBPCS family of archetypes, we addressed the limitations of Gonçalves, Hines, and Sterman's (2005) simulation work that lacks the analytical results and guidance for practitioners about the underlying root causes of supply chain dynamics in a hybrid MTS-MTO supply chain environment. The summarized findings and corresponding managerial implications are presented in Table 5:

System	Findings		Corresponding managerial implications
<i>Linear MTO</i>	<u>ω_n and ζ</u>	1. T_{sAdj} and T_{FGI} have a reverse impact on ω_n . 2. $\zeta \geq 1$ for all positive value of T_{sAdj} and T_{FGI} .	1. Quick forecasting smoothing and inventory error correction lead to rapid system's recovery to the steady state condition. 2. The MTO system always produces over-damped behaviour without oscillations.
	<u>Stability</u>	The real roots are always negative for positive value of T_{sAdj} and T_{FGI} .	The MTO system is permitted to be stable and robust for any forecasting methods and a positive value of inventory correction policy.

	<u>Dynamic response</u>	T_{sAdj} plays a major role in the A_N response, while T_{FGI} has a major impact on the FGI dynamical behaviour.	Bullwhip is mainly caused by the feedforward compensation in the semiconductor MTO supply chains: A careful compromise between advance stock availability and bullwhip effect should be considered.
<i>Nonlinear MTO</i>	<u>Dynamic response</u>	The same insights from the linear MTO system are confirmed.	The same managerial implications are obtained.
<i>Linear MTS</i>	<u>ω_n and ζ</u>	<ol style="list-style-type: none"> T_{AWIP} and T_{FWIP} have a reverse impact on ω_n. T_{AWIP} has a major influence on ζ. 	<ol style="list-style-type: none"> Quick CODP (AWIP) and FWIP inventory error correction leads to the system's rapid recovery to steady state conditions. The CODP (AWIP) inventory policy plays a major rule in the system's dynamic behaviour.
	<u>Stability</u>	The real roots are always negative for positive value of T_{FWIP} and T_{AWIP} .	The MTS system is guaranteed to be stable for any positive choice of the AWIP and FWIP inventory correction policies.
	<u>Dynamic response</u>	<ol style="list-style-type: none"> T_{sAdj}, T_{FGI}, T_{AWIP} and T_{FWIP} influence the bullwhip effect. However, T_{sAdj} and T_{AWIP} play major role for bullwhip level. T_{AWIP} is the key factor for system oscillations. 	<ol style="list-style-type: none"> The CODP inventory error correction and forecasting smoothing policy should be carefully tuned, due to their major influence on bullwhip level in the MTS system. The trade-off between the cost of bullwhip (e.g. capacity ramp up/down, labour hiring and firing) and the benefit of implementing CODP strategy should be considered, due to the system's oscillations are sensitive to the CODP policy settings.
<i>Nonlinear MTS</i>	<u>Dynamic response</u>	The same results regarding the impact of control policies on the dynamic behaviour can be confirmed in the nonlinear MTS system. However, the introduction of nonlinearities can reduce the bullwhip effect at the expense of increasing CODP inventory variability.	Beside the managerial insights gained from the linear analysis, the impact of capacity constraint should be considered for trade-offs design between the CODP inventory and capacity utilization when the hybrid MTS-MTO production strategy is adopted.

Table 5. Summary of the findings and managerial implications for the semiconductor hybrid MTS-MTO supply chains.
Source: the authors.

To answer research question 1, we gained deeper insights into the dynamic properties of the hybrid MTS-MTO supply chain system by simplifying and linearizing the original complex dynamic model, including developing the block diagram form, removing nonlinearities and redundancies and eliminating one echelon of the supply chain system. Thus, it is possible to extract the scenario of the linear hybrid MTS-MTO and implement a linear control engineering approach to analyse its fundamental dynamic properties. Although the simplification method is based on the semiconductor supply chain system, a similar approach can be applied to a board production-inventory based manufacturing system.

Regarding research question 2, through control engineering approaches, including Laplace transform, characteristic equations and the unit step response analysis, we reveal the fact that feedforward forecasting compensation and the CODP inventory correction policy play a major rule in the bullwhip effect in the semiconductor hybrid MTS-MTO system, instead of the production delay/feedback loop usually claimed in practice. Also, semiconductor managers may need to cautiously consider the balance between the cost of keeping an adequate CODP inventory to maintain the mode of MTS-MTO and the cost of supply chain dynamics, due to the fact that the policies' settings in the CODP point are significantly sensitive to the inventory variance and bullwhip level. This finding is helpful for practitioners to carefully consider relevant trade-offs when designing their hybrid MTS-

MTO system in the semiconductor industry.

Simulation analysis is also conducted based on a capacitated nonlinear hybrid semiconductor system to enhance qualitative insights derived from the linear analysis. The results show that the analytical results are robust in a nonlinear environment with capacity and non-negative order constrains. However, in the capacitated setting the bullwhip level is reduced at the expense of damaging CODP inventory performance (i.e. increased variability) when compared with the linear system under same policy settings. This phenomenon is well-recognized in literature (Cannella, Ciancimino, and Marquez 2008; Nepal, Murat, and Chinnam 2012; Lin, Jiang, and Wang 2014; Ponte et al. 2017). Furthermore, this paper also contributes to the analysis of supply chain dynamics in the semiconductor industry by uncovering the underlying mechanism of the bullwhip effect and comparing the dynamic performance differences between two different ordering archetypes. While we have undertaken some analysis of varying decision parameters with respect to proportional feedback controllers, i.e. T_{FWIP} , T_{AWIP} , T_{FGI} , T_{DAdj} , further dynamic analysis needs to be undertaken such as determining the impact of feedforward gains i.e. WOI^* , T_A and K_2/Y_U .

It should be acknowledged that the IOBPCS-based production control frameworks (linear or nonlinear representations) may not be capable to capture the nonlinear increase of cycle time in the semiconductor fab production *at high resources utilization condition* (Orcun, Uzsoy and Kempf 2006), due to the lead time modelling approaches, i.e. first order/third order delay under the fixed mean lead time assumption. To be more specific, with the increase of WIP level, longer time is required for the semiconductor fab system to transform releases into output, resulted by the nonlinear increase of cycle time in both mean and variability, which may lead to the different dynamic behaviour under the high capacity utilization level comparing the corresponding response of the IOBPCS family. Although a similar behaviour can be obtained from IOBPCS-based and non IOBPCS-based systems (e.g. the adoption of the clearing functions) *at low utilization level*, the exploration of alternative lead time/capacity modelling approaches in the IOBPCS family, e.g. Clearing Function based capacity models (Orcun, Uzsoy and Kempf 2006), in representing a more realistic semiconductor fab WIP congestion condition is strongly recommended for the future study.

Nevertheless, the linear analysis in this paper still offers robust and traceable insights for the effect of fundamental system structures (feedback, feedforward) and the corresponding control policies on the dynamic behaviour of the hybrid MTS-MTO system, which contribute to the analytical guidance of supply chain system design in the context of the semiconductor industry. The analytical stability region map gives a basic framework for examining stability condition in both linear and nonlinear environment. The well-established results derived from the linear system, bullwhip level, fill rate and the corresponding economic implications, for example, can be also used as the indicators to compare the nonlinear dynamic results. A good example is Ponte et al.'s (2017) method to set optimal capacity based on the benchmark of the well-established linear analysis results in a capacitated production environment. Although it is out of this paper's scope, we suggest this as a future research direction based on such a linearized model.

There are several other future research opportunities based on this study. First, the application of nonlinear control engineering approaches should be considered by researchers, in particular for the context of the semiconductor supply chains to guide practitioners design and improve their systems, although common nonlinearities presented in the IOBPCS ordering family already be analytically traced by utilizing such methods (Spiegler, Naim, et al. 2016; Spiegler, Potter, et al. 2016; Spiegler and Naim 2017). In addition, this study is limited to the analysis of the hybrid MTS-MTO system only and ignores cases in which the whole supply chain automatically switches to the pure MTS system if there is no feasible FGI/AWIP in the semiconductor production context. Future researchers can contribute to these areas by utilizing more advanced analytical methods and analysing the switch between different modes within supply chain systems. It should be noted that the MTS part we derived from the original supply chain model is a linear-based MRP system, thus it can easily be extended to accommodate capacity constraints (Mönch, Fowler, and Mason 2013), to represent more realistic

semiconductor manufacturing scenarios. This also gives rise to a possible future research opportunity to investigate the dynamic behaviour of capacitated semiconductor supply chains in responding to various fluctuation demands.

Reference

- Bahaji, N, and ME Kuhl. 2008. "A simulation study of new multi-objective composite dispatching rules, CONWIP, and push lot release in semiconductor fabrication." *International Journal of Production Research* 46 (14):3801-3824.
- Braunscheidel, Michael J, and Nallan C Suresh. 2009. "The organizational antecedents of a firm's supply chain agility for risk mitigation and response." *Journal of Operations Management* 27 (2):119-140.
- Brown, Alexander O, Hau L Lee, and Raja Petrakian. 2000. "Xilinx improves its semiconductor supply chain using product and process postponement." *Interfaces* 30 (4):65-80.
- Cannella, Salvatore, Elena Ciancimino, and Adolfo Crespo Marquez. 2008. "Capacity constrained supply chains: A simulation study." *International Journal of Simulation and Process Modelling* 4 (2):139-147.
- Chandra, Pankaj, and Sudheer Gupta. 1997. "Managing batch processors to reduce lead time in a semiconductor packaging line." *International Journal of Production Research* 35 (3):611-633.
- Chen, J., & Dong, M. (2014). Available-to-promise-based flexible order allocation in ATO supply chains. *International Journal of Production Research*, 52(22): 6717-6738.
- Chen, Youhua F, and Stephen M Disney. 2007. "The myopic order-up-to policy with a proportional feedback controller." *International Journal of Production Research* 45 (2):351-368.
- Chien, Chen-Fu, Yun-Ju Chen, and Jin-Tang Peng. 2010. "Manufacturing intelligence for semiconductor demand forecast based on technology diffusion and product life cycle." *International Journal of Production Economics* 128 (2):496-509.
- Christopher, Martin. 2016. *Logistics & supply chain management*. London: Pearson Higher Ed.
- Coyle, R.G. 1977. *Management system dynamics*. Chichester: John Wiley & Sons Australia, Limited.
- Dejonckheere, Jeroen, Stephen M Disney, Marc R Lambrecht, and Denis R Towill. 2002. "Transfer function analysis of forecasting induced bullwhip in supply chains." *International Journal of Production Economics* 78 (2):133-144.
- Dejonckheere, Jeroen, Stephen M Disney, Marc R Lambrecht, and Denis R Towill. 2003. "Measuring and avoiding the bullwhip effect: A control theoretic approach." *European Journal of Operational Research* 147 (3):567-590.
- Dejonckheere, Jeroen, Stephen M Disney, Marc R Lambrecht, and Denis R Towill. 2004. "The impact of information enrichment on the bullwhip effect in supply chains: A control engineering perspective." *European Journal of Operational Research* 153 (3):727-750.
- Disney, Stephen M, Denis R Towill, and Roger DH Warburton. 2006. "On the equivalence of control theoretic, differential, and difference equation approaches to modeling supply chains." *International Journal of Production Economics* 101 (1):194-208.
- Disney, Stephen Michael, and Denis Royston Towill. 2002. "A discrete transfer function model to determine the dynamic stability of a vendor managed inventory supply chain." *International Journal of Production Research* 40 (1):179-204.
- Dudek, Gregor, and Hartmut Stadler. 2005. "Negotiation-based collaborative planning between supply chains partners." *European Journal of Operational Research* 163 (3):668-687.
- Edghill, J, and DR Towill. 1990. "Assessing manufacturing system performance: frequency response revisited." *Engineering Costs and Production Economics* 19 (1-3):319-326.
- Forstner, Lisa, and Lars Mönch. 2013. "A heuristic to support make-to-stock, assemble-to-order, and make-to-order decisions in semiconductor supply chains." Proceedings of the 2013 Winter Simulation Conference.
- Geng Na and Jiang Zhibin. 2009. "A review on strategic capacity planning for the semiconductor manufacturing industry." *International Journal of Production Research* 47 (13):3639-3655.
- Gonçalves, Paulo, Jim Hines, and John Sterman. 2005. "The impact of endogenous demand on push-pull production systems." *System dynamics review* 21 (3):187-216.
- Grünwald, Herbert J, and Leonard Fortuin. 1992. "Many steps towards zero inventory." *European Journal of Operational Research* 59 (3):359-369.
- Gunasekaran, Angappa, Christopher Patel, and Ronald E McGaughey. 2004. "A framework for supply chain performance measurement." *International Journal of Production Economics* 87 (3):333-347.
- Harrison, Terry P, Hau L Lee, and John J Neale. 2005. *The practice of supply chain management: where theory and application converge*. New York: Springer
- Hofmann, E. (2017). Big data and supply chain decisions: the impact of volume, variety and velocity properties on the bullwhip effect. *International Journal of Production Research*, 55(17): 5108-5126.
- Hur, Y., Bard, J. F., & Chacon, R. (2017). Hierarchy machine set-up for multi-pass lot scheduling at semiconductor assembly

- and test facilities. *International Journal of Production Research*, 1-20.
- John, Simon, Mohamed M Naim, and Denis R Towill. 1994. "Dynamic analysis of a WIP compensated decision support system." *International Journal of Manufacturing System Design* 1 (4):283-297.
- Karabuk, Suleyman, and S David Wu. 2003. "Coordinating strategic capacity planning in the semiconductor industry." *Operations Research* 51 (6):839-849.
- Kim, Ji, and SH Kim. 2012. "Positioning a decoupling point in a semiconductor supply chain under demand and lead time uncertainty." *International Journal of Advanced Logistics* 1 (2):31-45.
- Kim, Seung-Hwan, John W Fowler, Dan L Shunk, and Michele E Pfund. 2012. "Improving the push-pull strategy in a serial supply chain by a hybrid push-pull control with multiple pulling points." *International Journal of Production Research* 50 (19):5651-5668.
- Lee, Hau L, Venkata Padmanabhan, and Seungjin Whang. 1997. "Information distortion in a supply chain: The bullwhip effect." *Management Science* 43 (4):546-558.
- Lee, Young Hoon. 2001. "Supply chain model for the semiconductor industry of global market." *Journal of Systems Integration* 10 (3):189-206.
- Lee, Young Hoon, Sunguk Chung, Byungjin Lee, and Kyung Hwan Kang. 2006. "Supply chain model for the semiconductor industry in consideration of manufacturing characteristics." *Production Planning & Control* 17 (5):518-533.
- Li, Q., & Disney, S. M. (2017). Revisiting rescheduling: MRP nervousness and the bullwhip effect. *International Journal of Production Research*, 55(7): 1992-2012.
- Lin, D., and C. K. M. Lee. 2011. "A Review of the Research Methodology for the Re-entrant Scheduling Problem." *International Journal of Production Research* 49 (8): 2221 – 2242.
- Lin, Junyi, Mohamed Mohamed Naim, Laura Purvis, and Jonathan Gosling. 2016. "The extension and exploitation of the inventory and order based production control system archetype from 1982 to 2015." *International Journal of Production Economics*, In press. doi: <http://dx.doi.org/10.1016/j.ijpe.2016.12.003>.
- Lin, Wen-jin, Zhi-bin Jiang, and Lei Wang. 2014. "Modelling and analysis of the bullwhip effect with customers' baulking behaviours and production capacity constraint." *International Journal of Production Research* 52 (16):4835-4852.
- Manary, Matthew P, and Sean P Willems. 2008. "Setting safety-stock targets at Intel in the presence of forecast bias." *Interfaces* 38 (2):112-122.
- Mönch, Lars, John W. Fowler, and Scott J. Mason. 2013. *Production Planning and Control for Semiconductor Wafer Fabrication Facilities*. Berlin: Springer-Verlag New York.
- Naim, M.M., Spiegler, V.L., Wikner, J. and Towill, D.R., 2017. "Identifying the causes of the bullwhip effect by exploiting control block diagram manipulation with analogical reasoning." *European Journal of Operational Research*. 263(1):240-246
- Naylor, J Ben, Mohamed M Naim, and Danny Berry. 1999. "Leagility: integrating the lean and agile manufacturing paradigms in the total supply chain." *International Journal of Production Economics* 62 (1):107-118.
- Nepal, Bimal, Alper Murat, and Ratna Babu Chinnam. 2012. "The bullwhip effect in capacitated supply chains with consideration for product life-cycle aspects." *International Journal of Production Economics* 136 (2):318-331.
- Nise, Norman S. 2007. *CONTROL SYSTEMS ENGINEERING*: John Wiley & Sons.
- Olhager, Jan. 2003. "Strategic positioning of the order penetration point." *International Journal of Production Economics* 85 (3):319-329.
- Orcun, Seza, and Reha Uzsoy. 2011. "The effects of production planning on the dynamic behavior of a simple supply chain: an experimental study." In *Planning Production and Inventories in the Extended Enterprise*, 43-80. Springer.
- Orcun, Seza, Reha Uzsoy, and Karl Kempf. 2006. "Using system dynamics simulations to compare capacity models for production planning." The 38th conference on Winter simulation.
- Ponte, Borja, Xun Wang, David de la Fuente, and Stephen M Disney. 2017. "Exploring nonlinear supply chains: the dynamics of capacity constraints." *International Journal of Production Research* 55 (14):4053-4067.
- Popplewell, Keith, and Maurice C Bonney. 1987. "The application of discrete linear control theory to the analysis and simulation of multi-product, multi-level production control systems." *International Journal of Production Research* 25 (1):45-56.
- Qi, Chao, Appa Iyer Sivakumar, and Stanley B Gershwin. 2008. "Impact of production control and system factors in semiconductor wafer fabrication." *IEEE Transactions on Semiconductor Manufacturing* 21 (3):376-389.
- Rastogi, Aditya P, John W Fowler, W Matthew Carlyle, Ozgur M Araz, Arnold Maltz, and Burak Büke. 2011. "Supply network capacity planning for semiconductor manufacturing with uncertain demand and correlation in demand considerations." *International Journal of Production Economics* 134 (2):322-332.
- Riddalls, CE, and S Bennett. 2002. "The stability of supply chains." *International Journal of Production Research* 40 (2):459-475.
- Sampath, Siddhartha, Esma S Gel, John W Fowler, and Karl G Kempf. 2015. "A decision-making framework for project portfolio planning at Intel Corporation." *Interfaces* 45 (5):391-408.

- Sarimveis, Haralambos, Panagiotis Patrinos, Chris D. Tarantilis, and Chris T. Kiranoudis. 2008. "Dynamic modeling and control of supply chain systems: A review." *Computers & Operations Research* 35 (11):3530-3561.
- Schwarzenbach, J, and KF Gill. 1992. *System Modelling and Control Edward Arnold*. London: Elsevier Limited.
- Simon, Herbert A. 1952. "On the application of servomechanism theory in the study of production control." *Econometrica: Journal of the Econometric Society*:247-268.
- Sipahi, Rifat, and Ismail Ilker Delice. 2010. "Stability of inventory dynamics in supply chains with three delays." *International Journal of Production Economics* 123 (1):107-117.
- Spiegler, Virginia LM, and Mohamed M Naim. 2017. "Investigating sustained oscillations in nonlinear production and inventory control models." *European Journal of Operational Research* 261 (2):572-583.
- Spiegler, Virginia LM, Mohamed M Naim, Denis R Towill, and Joakim Wikner. 2016. "A technique to develop simplified and linearised models of complex dynamic supply chain systems." *European Journal of Operational Research* 251 (3):888-903.
- Spiegler, Virginia LM, Mohamed M Naim, and Joakim Wikner. 2012. "A control engineering approach to the assessment of supply chain resilience." *International Journal of Production Research* 50 (21):6162-6187.
- Spiegler, Virginia LM, Andrew Thomas Potter, MM Naim, and Denis Royston Towill. 2016. "The value of nonlinear control theory in investigating the underlying dynamics and resilience of a grocery supply chain." *International Journal of Production Research* 54 (1):265-286.
- Sterman, John D. 1989. "Modeling managerial behavior: Misperceptions of feedback in a dynamic decision making experiment." *Management Science* 35 (3):321-339.
- Sun, Yang, Dan L Shunk, John W Fowler, and Esma S Gel. 2010. "Strategic factor-driven supply chain design for semiconductors." *California Journal of Operations Management* 8 (1):31-43.
- Terwiesch, Christian, Z Justin Ren, Teck H Ho, and Morris A Cohen. 2005. "An empirical analysis of forecast sharing in the semiconductor equipment supply chain." *Management Science* 51 (2):208-220.
- Towill, Denis R. 1982. "Dynamic analysis of an inventory and order based production control system." *International Journal of Production Research* 20 (6):671-687.
- Towill, Denis Royston. 1970. *Transfer function techniques for control engineers*. London Iliffe.
- Towill, DR. 1977. "Exponential smoothing of learning curve data." *International Journal of Production Research* 15 (1):1-15.
- Truxal, John G, and L Weinberg. 1955. "Automatic feedback control system synthesis." *Physics Today* 8:17.
- Vicente, J. J., Relvas, S., & Barbosa-Póvoa, A. P. (2017). Effective bullwhip metrics for multi-echelon distribution systems under order batching policies with cyclic demand. *International Journal of Production Research*, 1-27.
- Wang, Wenlin, and Daniel E Rivera. 2008. "Model predictive control for tactical decision-making in semiconductor manufacturing supply chain management." *IEEE Transactions on Control Systems Technology* 16 (5):841-855.
- Wang, Wenlin, Daniel E Rivera, and Karl G Kempf. 2007. "Model predictive control strategies for supply chain management in semiconductor manufacturing." *International Journal of Production Economics* 107 (1):56-77.
- Wang, Xun, Stephen M Disney, and Jing Wang. 2012. "Stability analysis of constrained inventory systems with transportation delay." *European Journal of Operational Research* 223 (1):86-95.
- Wang, Xun, Stephen M Disney, and Jing Wang. 2014. "Exploring the oscillatory dynamics of a forbidden returns inventory system." *International Journal of Production Economics* 147:3-12.
- Warburton, Roger DH, Stephen M Disney, Denis R Towill, and Jonathan PE Hodgson. 2004. "Further insights into 'the stability of supply chains'." *International Journal of Production Research* 42 (3):639-648.
- Wikner, Joakim, Mohammed Naim, and Denis Towill. 1992. "The system simplification approach in understanding the dynamic behaviour of a manufacturing supply chain." *Journal of Systems Engineering* 2:164-178.
- Zhang, C., Bard, J. F., & Chacon, R. (2017). Controlling work in process during semiconductor assembly and test operations. *International Journal of Production Research*, 1-25.
- Zhou, Li, and Stephen M Disney. 2006. "Bullwhip and inventory variance in a closed loop supply chain." *Or Spectrum* 28 (1):127-149.
- Zhou, Li, Stephen Disney, and Denis R Towill. 2010. "A pragmatic approach to the design of bullwhip controllers." *International Journal of Production Economics* 128 (2):556-568.
- Zhou, Li, Mohamed M Naim, and Stephen M Disney. 2017. "The impact of product returns and remanufacturing uncertainties on the dynamic performance of a multi-echelon closed-loop supply chain." *International Journal of Production Economics* 183:487-502.
- Zhou, Li, Mohamed M Naim, Ou Tang, and Denis R Towill. 2006. "Dynamic performance of a hybrid inventory system with a Kanban policy in remanufacturing process." *Omega* 34 (6):585-598.