

This is an Open Access document downloaded from ORCA, Cardiff University's institutional repository: <https://orca.cardiff.ac.uk/id/eprint/120167/>

This is the author's version of a work that was submitted to / accepted for publication.

Citation for final published version:

Valera Medina, Agustin , Gutesa, M., Xiao, H., Pugh, D. , Giles, A. , Goktepe, B., Marsh, R. and Bowen, P. 2019. Premixed ammonia/hydrogen swirl combustion under rich fuel conditions for gas turbines operation. *International Journal of Hydrogen Energy* 44 (16) , pp. 8615-8626. 10.1016/j.ijhydene.2019.02.041

Publishers page: <http://dx.doi.org/10.1016/j.ijhydene.2019.02.041>

Please note:

Changes made as a result of publishing processes such as copy-editing, formatting and page numbers may not be reflected in this version. For the definitive version of this publication, please refer to the published source. You are advised to consult the publisher's version if you wish to cite this paper.

This version is being made available in accordance with publisher policies. See <http://orca.cf.ac.uk/policies.html> for usage policies. Copyright and moral rights for publications made available in ORCA are retained by the copyright holders.



Premixed Ammonia/Hydrogen Swirl Combustion under Rich Fuel Conditions for Gas Turbines Operation

Valera-Medina A^a, Gutesa M^b, Xiao H^c, Pugh D^a, Giles A^a, Goktepe B^a, Marsh R^a, Bowen P^a

^aCollege of Physical Sciences and Engineering, Cardiff University, Queen's Building, Wales, UK.

^bTermoinzinjering, Dragice Pravice 52, 23000, Zrenjanin, Serbia

^c College of Chemistry and Environmental Engineering, Shenzhen University, Shenzhen 518060, China

Abstract

Energy storage is one of the highest priority challenges in transitioning to a low-carbon economy. Fluctuating, intermittent primary renewable sources such as wind and solar require low-carbon storage options to enable effective load matching, ensuring security of supply. Chemical storage is one such option, with low or zero carbon fuels such as hydrogen, alcohols and ammonia having been proposed. Ammonia provides zero-carbon hydrogen storage whilst offering liquefaction at relatively low pressures and atmospheric temperatures, enabling ease of transportation in a pre-existing infrastructure. Ammonia can also be used directly as a fuel in power plants such as gas turbines to avoid complete conversion back to hydrogen. It is a relatively unreactive fuel, and so it is of interest to explore the potential utilisation of ammonia/hydrogen mixtures. Hence, the goal of this paper is to provide a first assessment of the suitability of a chosen 70%NH₃-30%H₂ (%vol) blend for utilisation within a gas turbine environment, based on primary combustion diagnostics including combustion stability – via OH chemiluminescence - and emissions (NO_x and NH₃). An established optical generic swirl-burner enabled studies of the influence of equivalence ratio ($\phi > 1$), ambient temperature ($< 484 \pm 10$ K) and bypass air, with a focus on NO_x reduction, one of the main challenges for ammonia combustion. A numerical GT cycle model is developed alongside the experimental investigation. The results demonstrate that the blend has considerable potential as a fuel substitute with reasonable combustion stability and significant reduction of emissions for the cases without bypass air, due to increased chemical reactivity of unburned ammonia. However, emissions are still above those recommended for gas turbine cycles, with a theoretical cycle that still produces low efficiencies compared to DLN methane, highlighting the requirement for new injection techniques to reduce NO_x/unburned NH₃ in the flue gases whilst ensuring increased power outputs.

Keywords: Ammonia combustion; gas turbines; hydrogen flames

Nomenclature

A_i	Pre-exponential factor [First order rate law - 1/s; second order rate law - $\text{cm}^3/\text{mol}\cdot\text{s}$]	R	Universal gas constant [J/molK]
b	Fuel mass flowrate relative to the air mass flowrate at the combustion chamber inlet [-]	r_{air}	Cooling air mass flow specified to compressor inlet mass flow [-]
c_p	Specific heat at constant pressure [kJ/kgK]	T	Temperature [K]
E_a	Activation energy of the reaction [cal/mol]	T_o	Inlet compressor temperature [K]
h_{CC1}	Enthalpy of steam at the combustion chamber inlet [kJ/kg]	T_2	Outlet compressor temperature [K]
h_{CC2}	Enthalpy of steam at the combustion chamber outlet [kJ/kg]	T_{3t}	Combustion products temperature at the turbine inlet [K]
h_{fuel}	Specific enthalpy of fuel at combustion chamber inlet [kJ/kg]	T_{At}	Combustion products temperature at the end of the expansion [K]
L_c	Specific work of compression [kJ/kg]	z	Air mass flow for sealing relative to air mass flow at the compressor inlet [-]
L_{GT}	Plant specific work [kJ/kg]	α	Ratio of vapour mass flow and fuel mass flow at the combustion chamber inlet [-]
LHV	Lower heating value [kJ/kg]	η_{CC}	Efficiency of a combustion chamber [-]
L_T	Overall specific work of the expansion of the combustion products and cooling air mixture [kJ/kg]	η_{GTP}	Efficiency of a plant [-]
\dot{m}_{cp}	Combustion products mass flow [kg/s]	η_m	Mechanical efficiency [-]
\dot{m}_{fuel}	Fuel mass flow at the combustion chamber inlet [kg/s]	η_{pC}	Compressor polytropic efficiency [-]
\dot{m}_1	Air mass flow at the compressor inlet [kg/s]	η_{pT}	Turbine polytropic efficiency [-]
\dot{m}_2	Air mass flow at the combustion chamber inlet [kg/s]	Π_C	Compressor pressure ratio [-]
M	Cooling air distribution factor [-]		
L_{GT}	Plant specific work [kJ/kg]		
n	Temperature exponent of the i th reaction [-]		
p	Pressure [Pa]		
q_{sup}	Supplied heat [kJ/kg]		

1. Introduction

Ammonia is the second most bulk manufactured chemical, having been mass produced throughout the world for more than a century, with its manufacture still thought to account for approximately 2% of global energy production. While ammonia is a toxic and corrosive gas, the wide-ranging experience and expertise in synthesis, transportation and utilization of ammonia significantly mitigates any concerns about its further exploitation. The development of ammonia-based artificial fertilizers is well documented and it has been reported that the population growth from 1.6B in 1900 to ~6.7B currently is due to fertilizers boosting world population [1]. In parallel, future energy systems require effective, affordable methods for energy storage. Chemical storage of energy is one option being considered via hydrogen or carbon-neutral hydrogen derivatives. One such example is ammonia, which has been identified as a sustainable fuel for mobile and remote applications. Therefore, the vast experience and use of the chemical, combined with the growing need of reliable and cost effective methods for energy storage have led to the recognition of ammonia as an energy storage medium that presents a great variety of opportunities from cooling/heating to fuel for power generation.

Regarding power generation, current renewable energy systems require effective, affordable methods for energy storage in order to mitigate their fluctuating nature. Ammonia has been identified as a sustainable fuel for mobile and remote applications [2]. However, a viable energy system based on ammonia faces four primary barriers:

1. Ammonia Carbon-free synthesis
2. Power generation at utility-scale from the ammonia production.
3. Public acceptance through safe regulations and appropriate community engagement.
4. Economic viability for integration of technologies and green production of ammonia.

Barrier (1) above is important because today's ammonia production methods are heavily reliant on fossil fuels. Similarly, Barrier (2) above is also critical, since most developments to date have focused on improving small- to medium-scale devices such as reciprocating engines. However, power output from such units is relatively modest, typically in the range of 0.1 – 1 MW. Moreover, to determine its viability, any potential system based on ammonia will also need to undergo a thorough health and safety impact analysis and review of current associated legislation, as well as take account of public and end user perceptions and acceptability (Barrier 3). Finally, the Economic viability (barrier 4) of such systems needs to be proved, encouraging investors to set the foundations of both industries and suppliers capable of delivering equipment and integrated systems that produce green ammonia for its use in power generation. These aspects require careful consideration, thus recognizing urgent further research needs for the realization of a "Hydrogen through Carbon-Free Ammonia Economy" via storage of renewable energy.

Considerable work in terms of gas turbines development was carried out during the 1960's (Barrier 2 above). The most representative projects were related to propulsion applications that demonstrated the high potential of ammonia as fuel [3-5]. However, the low cost of fossil fuels led to the end of these programs that would be eventually re-activated a few decades later. More recently, a number of different approaches have been followed to use ammonia as a flexible fuel in gas turbines, with most of them finding that emissions are the main concern when burning ammonia directly [6-10]. The work from the Space Propulsion Group (SPG) [6-7] has demonstrated the challenges of the use of ammonia as fuel for propulsion gas turbines, thus leading to the development of new combustion systems based on porous materials that can efficiently burn ammonia blends, although this is achieved only at low power outputs. In parallel, the Fukushima Renewable Energy Institute (FREA), has developed fuel flexibility platforms to burn liquid NH_3 produced from renewable sources, i.e. wind and solar, in combination with kerosene in a 50 kW micro-gas turbine. Diffusion combustion has been employed in the prototype bi-fuel combustor due to its flame stability and it has been demonstrated that the equipment can be run using ammonia-kerosene blends at different concentrations [9-10]. FREA and universities leading this research are now at the brink of showing the potential of pure ammonia gas turbine combustion via studies that range from numerical simulations [11] to demonstration studies [12].

Valera-Medina et al. have also been working on the topic using ammonia-hydrogen/methane blends for gas turbines combustion [13-15]. Numerical results have demonstrated the need for more accurate chemical models that can provide initial insights into both the combustion process and the chemical reactions of various species when these blends are used under atmospheric and high temperature/pressure conditions as those found in gas turbine equipment. Moreover, the use of blends such as ammonia/methane present a new alternative for highly energy intensive industries that require constant backup from the power grid to run their processes. One example of these industries is the steelmaking process that either produces or consumes vast amounts of ammonia. As demonstrated by Valera-Medina et al [15] there is reaction balance between methane and ammonia passed the stoichiometric conditions ($\phi \sim 1.1$), region where low emissions and high power are produced, leading potentially to the decrement of large quantities of CO_2 accompanied with recovery and storage of a chemical that many industries have been considered a by-product waste. Jojka and Slefarski [16] presented some investigation with low ammonia content (from 1 to 5%) in methane flames. Overall values of NO concentration derived from experimental and numerical studies, showing good correlations for rich fuel conditions. Conversion factors of NH_3 to NO achieved the lowest value equal to 40.4% in a rich mixture with 5% ammonia content. However, the NH_3 conversion to NO is not complete and trends are not linear, thus requiring further research.

Further work [17] has detailed exhaust gas compositions of a particular burner under atmospheric pressure and various stoichiometric conditions in combination with fossil fuels. It has been demonstrated that as the equivalence ratio increases, unburnt species such as NH_3 , CO and total hydrocarbons decrease in contrast to NO_x and that the burner achieves combustion efficiencies above 97% for ammonia-mixing-ratios below 50%. It has been reported that it has been difficult to achieve low emissions and high combustion efficiency in a single-stage combustor, and hence two-stage combustion systems (rich-lean or lean-burn with secondary ammonia supply) have been conceptualized, with initial studies suggesting low NO_x and unburnt gas species emissions while maintaining high combustion efficiencies [18].

Regarding the use of other combustion promoters, Xiao et al [19] has recently shown that ammonia/hydrogen blends under these conditions have a potential for large power generation with low NO_x production at high pressurized conditions. Since the latter studies have been only carried out numerically, further experimental tests are required to demonstrate the concept and identify progression pathways of implementation. Preliminary experiments were performed by Valera-Medina et al [20] employing ammonia/hydrogen at 50/50% (vol), finding that under lean conditions NO_x emissions were prohibitive while stability was compromised to a very narrow equivalence ratio (ϕ) range. Those findings set the path for further experimentation at higher equivalence ratios above stoichiometric values, range that has shown in previous simulations a decrease in nitrogen oxide production [19-20].

In terms of application, companies such as NUON have started ambitious programs to develop their capabilities in terms of ammonia-fired systems. The most notable is the “Power-to-Ammonia” program in which NUON collaborates with TU Delft, Proton Ventures, OCI Nitrogen, AkzoNobel, ISPT and the University of Twente [21-22]. The NUON project perceives ammonia as a “superbattery” that stores excess renewable power at large scale over long periods. Meanwhile, Japanese companies have recently announced [23] that Chugoku Electric Power Company has conducted a series of trials at its Mizushima power plant where ammonia was added to the 155MW coal-fired plant at a rate of 450 kg/hr (~2.25 MW). The company confirmed that the addition of the ammonia did not cause the plant’s power efficiency to reduce, while IHI recently announced co-firing coal with 20% ammonia in the biggest demonstration (10MW) carried out to this day [24]. Nevertheless, estimations of efficiency performance of ammonia blended cycles for gas turbines are inexistent to the knowledge of the authors, issue that still impacts on further propagation of the concept amongst industrialist, thus constraining the resolution of barrier (4).

Thus, this paper presents a series of experimental, numerical and analytical tests carried out to determine the combustion complexity of ammonia/hydrogen swirl combustion under rich conditions, fundamental data of the reaction chemistry occurring through the process under these specific settings, and a first insight of a theoretical ammonia/hydrogen gas turbine cycle for efficiency prediction, respectively. The results will permit a better understanding of such a process aiming at the development of an industrially based system, moving forward to tackle barriers (2) and (4) above mentioned.

2. Setup

2.1. Experimental Study

All experiments were performed at Cardiff University's Gas Turbine Research Centre (GTRC). For the present study, a High Pressure Optical Chamber (HPOC) was fitted with a generic lean pre-mixed swirl burner, Fig. 1, with swirl number $S_g = 0.8$.

The programme was initiated setting a blend of 60% NH_3 -40% H_2 (%vol) which proved to be unstable. By contrast, a 70% NH_3 -30% H_2 (%vol) blend demonstrated stable combustion behaviour, and so was selected for use throughout this study. Experimental characterisations were undertaken at a HHV power output of 39.3kW under atmospheric pressure, Table 1. Each experiment was analysed for 3 different inlet temperatures (288 ± 5 K, 400 ± 7 K and 484 ± 10 K). In order to characterise the impact of change in inlet temperature, together with dilution in the post combustion zone and observe the impact on chemical reactivity, 63.7 g/s of bypass air was used for comparison purposes with the cases evaluated at 288K inlet temperature.

Table 1. Test points matrix. Each experiment was characterised at 3 different inlet temperatures (288 ± 5 K, 400 ± 7 K and 484 ± 10 K).

<i>Case</i>	<i>NH₃ [g/s]</i>	<i>H₂ [g/s]</i>	<i>O₂ [g/s]</i>	<i>Air [g/s]</i>	<i>Equivalence Ratio ϕ</i>
1	1.321	0.067	2.403	10.314	1.00
2	1.321	0.067	2.187	9.387	1.10
3	1.321	0.067	2.005	8.604	1.20
4	1.321	0.067	1.920	8.240	1.25
5	1.321	0.067	1.849	7.938	1.30
6	1.321	0.067	1.718	7.375	1.40

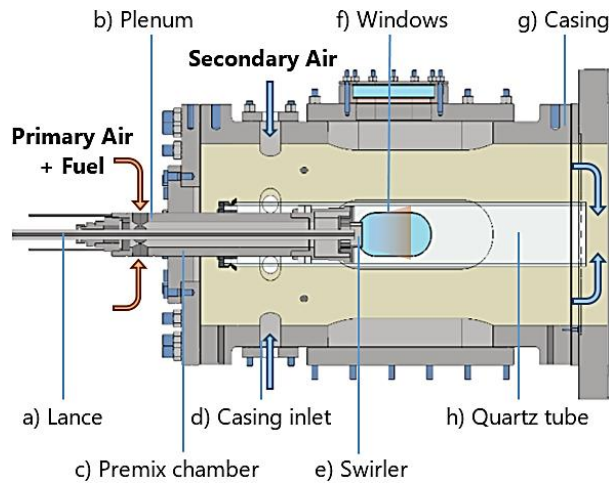

Fig. 1. Burner Schematic

OH* chemiluminescence measurements were taken for all conditions. A Dantec Dynamics Hi Sense Mk II CCD camera with 1.3 megapixel resolution coupled to a Hamamatsu C9546-03L image intensifier was utilised throughout. A bespoke 78 mm focal length lens (F-stop = $f/3.8$) capable of capturing light in the UV wavelength range was installed on the image intensifier along with a narrow band pass filter centred at 307 nm (FWHM = 10 nm). Chemiluminescence images were post-processed using the established Abel deconvolution methodology to enable spatial resolution. An Avigilon 5 Mp H.264 HD camera was used to capture the flame during stability analysis and provide qualitative insights of the flame behaviour.

An integrated Signal Instruments gas analysis system comprising several analysers was used. The system includes: a heated vacuum chemiluminescence analyser (Signal 4000VM) to quantify NO_x concentrations; a system for quantifying trace concentrations of NH_3 in the flue gas, which forms a subsystem to the 4000VM NO_x analyser; a paramagnetic O_2 9000MGA sensor (up to 22.5%). Measured errors are estimated at ~5%.

2.2. Numerical Analysis

2.2.1. Chemical Reactor Network (CRN)

Considering the high computational cost required for 3D CFD analyses, a 1D simulation was conducted using a Chemical Reactor Network (CRN) model, which has shown to be viable for gas turbine simulations previously [25-26]. The reactor network has two clusters, Fig. 2. The first cluster represents the swirling flame with a central recirculation zone (CRZ) whose recirculation was set at 20% of the product gases. Recirculation strength was approximated from previous experimental campaigns using similar burners [27-28]. The second cluster uses a single Plug Flow Reactor for post-flame processes along a 0.1 m duct. Simulations were conducted using CHEMKIN-PRO. As inlet conditions, the simulation was carried out using atmospheric and preheated temperatures as in the experimental trials.

The model was calibrated to the NO_x experimental values in order to determine heat losses that mainly accounted to the primary combustion zone. Then, having the model calibrated, further analyses were conducted on other species and posterior reactions through the post-flame zone. Mass flow rates and chemical composition were set as in the experimental campaign under atmospheric pressure conditions.

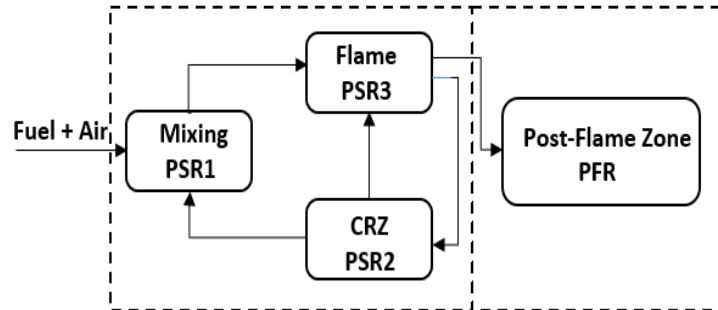

Fig. 2. Gas Turbine Network

2.2.1.1. Improved NH_3/H_2 Chemical Reaction Model

To study ammonia/hydrogen combustion in gas turbines a detailed chemical-kinetics mechanism which can comprehensively validate the combustion properties under high pressure conditions is required. Mathieu's mechanism was optimised using shock-tube experiments of ammonia ignition delay time measurements under pressure conditions of up to 30 atm. Therefore, the chemical kinetic model proposed in the present work was mostly based on recent work performed by Mathieu under high-pressure conditions [29]. Nevertheless, it was noted that the mechanism was not accurate in its prediction of NO_x emissions [30]. To improve mechanism performance on NO_x emissions and burning velocity prediction, several reactions were modified according to kinetic analyses of the main reactions as shown in Table 2.

The procedure to establish this improved mechanism is firstly to find out the most sensitive reactions and by modifying rate constants of the latter, the performance of certain combustion properties can be improved. Then through numerical calculations using the improved mechanism, choices can be made to achieve better accuracy of all combustion properties. In the present study, an improved mechanism model with five modified reactions was used to overcome the problem of underestimating NO_x emissions associated with Mathieu's mechanism. Calculations using the improved mechanism show a better comprehensive performance than the original Mathieu's mechanism. In terms of NO_x emission predictions, by comparing numerical simulation results with experimental data, the improved mechanism model, which was developed previously [30], showed better accuracy than other mechanisms. Under different ammonia/hydrogen fuel blends and equivalence ratios (fuel lean to fuel rich conditions), this improved mechanism was validated for laminar burning velocity calculations. Numerical prediction of laminar burning velocity for ammonia combustion under high pressure conditions also demonstrated that the improved mechanism is capable of predicting burning velocities

under gas turbine conditions. For ignition delay time calculation, the improved mechanism model denoted good performance for highly diluted ammonia mixtures under high pressure conditions as well. Therefore, the improved chemical-kinetics mechanism model has shown to be capable of predicting different essential combustion properties under gas turbine related conditions, thus it will be used for the study of ammonia/hydrogen combustion in gas turbine. Further details of the model are given in [30].

Table 2. Modified reactions compared with the Mathieu mechanism. *Units in cm³, mol, seconds.

<i>Reactions</i>	<i>A*</i>	<i>n [-]</i>	<i>Ea [cal/mol]</i>	<i>Ref.</i>
N+NO=N ₂ +O	2.10E+13	0	0	[31]
NO+H+M=HNO+M	1.50E+15	-0.4	0	[32]
HNO+H=NO+H ₂	4.40E+11	0.7	650	[32]
N ₂ O+H=NH+NO	6.70E+22	-2.16	37155	[33]
N ₂ O+H=N ₂ +OH	5.00E+13	0	1.52E+04	[34]

2.2.2. Gas Turbine Cycle Simulation

Combustion results from the CRN using the improved reaction model were used as inputs into a newly developed mathematical model for design and off design gas turbine analyses [35]. The mathematical model considers the processes of non-adiabatic expansion and cooling in the turbine with the continual distribution of the cooling air along the gas turbine. The computation of the expansion process of the combustion gases and cooling air is done separately.

The specific work of compression is calculated as,

$$L_C = c_{p_{air}} \Big|_1^2 \cdot T_1 \cdot \left(\Pi_C^{\frac{1}{\eta_{pC}} \cdot \frac{R_{air}}{c_{p_{air}} \Big|_1^2}} - 1 \right) \quad (1)$$

The compressor outlet air temperature is obtained using the following equation,

$$T_{2t} = T_0 \cdot \Pi_C^{\frac{1}{\eta_{pC}} \cdot \frac{R_{air}}{c_{p_{air}} \Big|_0^2}} \quad (2)$$

A coefficient “b” is employed as the ratio of fuel mass flow to air mass flow accessing the combustion chamber. In order to better understand the influence of fuel enthalpy, this parameter was introduced into the model for simulation of the flow behaviour, heat transfer and energy transformation. After implementing the adjustments in the mathematical model, coefficient b is calculated using equation (3),

$$b = \frac{\dot{m}_{fuel}}{\dot{m}_2} = \frac{c_{p_{cp}} \Big|_0^3 \cdot (T_{3t} - T_0) - c_{p_{air}} \Big|_1^2 \cdot (T_{2t} - T_0)}{\eta_{CC} \cdot (LHV + h_{fuel}) - c_{p_{cp}} \Big|_0^3 \cdot (T_{3t} - T_0) \cdot (1 + \alpha) - \alpha \cdot (h_{CC2} - h_{CC1})} \quad (3)$$

Equation (3) is determined from the energy balance equation of the combustion chamber. It represents an indicator of fuel and air consumption in the chamber. In cycle analyses, the parameter is used for determination of possible errors during parameter prediction, as mass flows of both fuel and air at the combustion chamber are previously determined (i.e. being known input values). Having the value of b , the specific work of the expansion in the gas turbine is calculated as,

$$L_T = c_{p_{cp-air}} \Big|_3^4 \cdot \frac{(1-z-r_{air}) \cdot (1+b \cdot (1+\alpha)) \cdot T_{3t} + r_{air} \cdot M \cdot T_{2t}}{(1-z-r_{air}) \cdot (1+b \cdot (1+\alpha)) + r_{air}} \cdot \left(1 - \Pi_T^{\frac{\eta_{pT} \cdot R_{cp-air} \cdot (3-4)}{c_{p_{cp-air}} \Big|_3^4}} \right) \quad (4)$$

As for the supplied heat equation, this is also obtained from the combustion chamber energy balance,

$$q_{sup} = \frac{1}{\eta_{cc}} \cdot \left[(1-z-r_{air}) \cdot (1+b \cdot (1+\alpha)) \cdot c_{p_{cp}} \Big|_0^3 \cdot (T_{3t} - T_0) - (1-z-r_{air}) \cdot c_{p_{air}} \Big|_0^2 \cdot (T_{2t} - T_0) - \alpha \cdot b \cdot (1-z-r_{air}) \cdot (h_{cc2} - h_{cc1}) \right] - b \cdot (1-r_{air}) \cdot h_{fuel} \quad (5)$$

Finally, the efficiency of the entire gas turbine plant is defined as:

$$\eta_{GTP} = \frac{(L_T - L_C) \cdot \eta_m}{q_{sup}} \quad (6)$$

An industrial Rolls-Royce Allison 501-KB5 gas turbine was employed in the study. For model validation, the same input parameters utilised during the test campaign of the reference gas turbine plant [36] were applied, with error values within the range of experimental uncertainty for the operating conditions considered. In addition to the reference gas turbine plant data, the values of pressure drop in the compressor and the combustion chamber were also quantified, as well as the polytropic efficiencies of the compressor and turbine, the combustion efficiency and mechanical efficiency. An inlet temperature of 567K and 9.67 bar pressure, i.e. similar to those of industrial systems, are adopted for all calculations performed.

For the study, a 70%NH₃-30%H₂ (vol) blend was used at $\phi=1.20$, as this condition showed the best emissions performance. Comparison was carried out with the engine running on pure methane at 0.65 equivalence ratio, representative condition of Dry Low NO_x (DLN) current technologies. Recommendations on further development are presented to ensure competitiveness of ammonia-based technologies.

3. Results and Discussion

3.1. Experiments

Initial experimental trials demonstrated that ammonia blends with 40% hydrogen (vol) produce unstable flame features prone to flashback. Although hydrogen addition would improve the reaction of the blend, the high diffusivity of the hydrogen molecule leads to its faster reaction with the surrounding oxygen, thus increasing flashback propensity, as previously observed somewhere else [20]. Therefore, the blend was reduced to 30% hydrogen (vol), which provides a LHV of ~22.9 MJ/kg, lower than the value of

50MJ/kg obtained from methane but similar to methanol (22.7 MJ/kg). However, combustion stabilization was achieved with a characteristic flame composed by both hydrogen (outer region) and ammonia (inner zone) combustion regions [20]. The flame, steady in location, position and features, was employed for quantitative analyses. An image of the stable flame is shown in Fig.3.

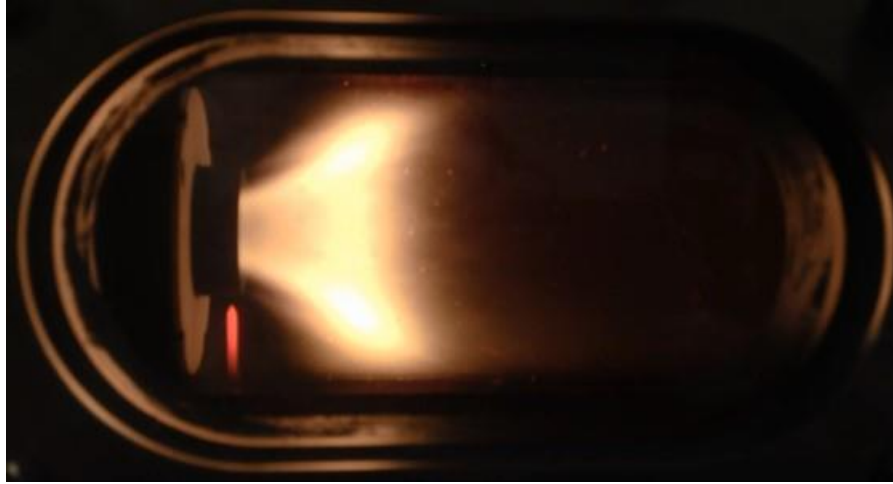

Fig. 3. Representative stable combustion, case 3, table 1.

OH* chemiluminescence identified the change in the position of the flame with considerably higher intensity in the production of radicals at $\phi=1.0$, Fig. 4, beyond which OH intensity decays as a consequence of the reduced oxygen. Notwithstanding that oxygen has already been depleted relative to the stoichiometric condition for the higher equivalence ratio conditions, OH radical intensities still denote high values under fuel rich conditions, suggesting little change in the heat release location and flame position.

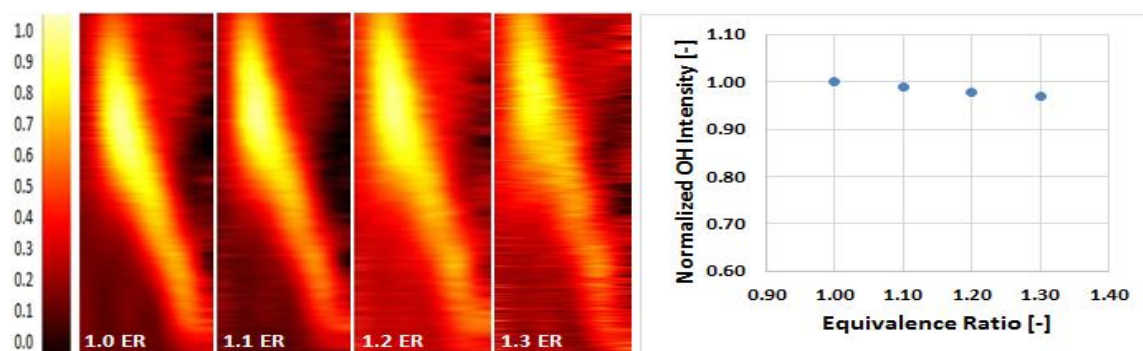

Fig. 4. Left) Deconvoluted OH intensity at different ϕ . Right) Normalized intensities at highest value ($\phi = 1.0$)

With air preheat up to $\sim 484\text{K}$, the high intensity boundary of the OH* profile showed a considerable contraction of $\sim 24\%$ compared to atmospheric inlet temperature condition, with most of the OH located at the flame front, in contrast to the atmospheric temperature case where a considerable intensity peak

pervades the primary zone, Fig. 5. Thus, as expected, the increase in inlet temperature compacts the flame front, rendering it more reactive and stable.

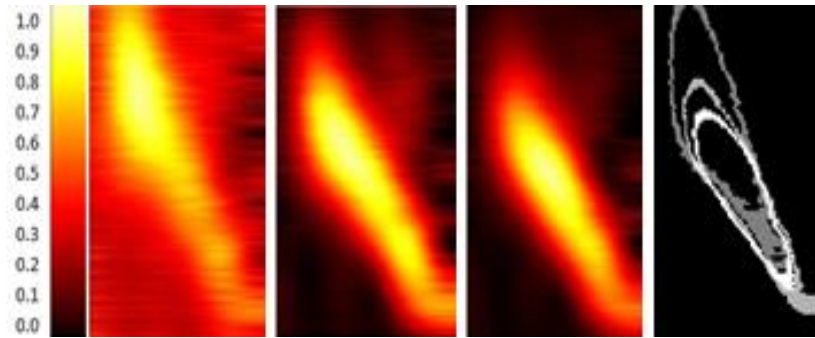

Fig. 5. Impact of inlet temperature on OH* chemiluminescence, case 3, table 1. A) 288K; B) 400K; C) 487K; D) Comparison between high OH intensity (between 0.6-0.7 A.U.) profiles. Arbitrary Units [A.U.]

Experiments using by-pass air were undertaken to observe the impact of dilution via post-combustion air on the combustion process at 288K inlet temperature conditions, Fig. 6. Original images show that there is a minor shift in the production of the OH* species, from 1.0 to ~0.973 (normalized OH intensity), especially close to the flame envelope, ensuring no interaction between flame zone and secondary air. Thus, by-pass air does not have a critical impact on the flame position, but as discussed later, it does influence the post-flame chemistry

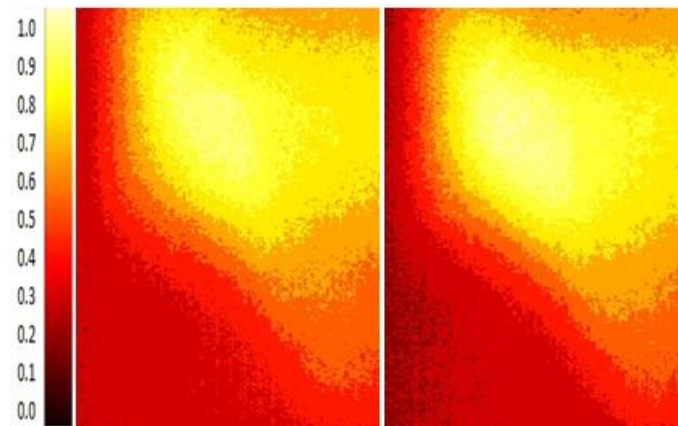

Fig. 6. Impact of bypass air to the production of OH radicals in the main flame. Left) By-pass air condition; right) No bypass air. Arbitrary Units [A.U.]

In terms of emissions, NO_x was the primary species measured as this is the dominant pollutant from ammonia-based fuel reactions, Fig. 7. The results demonstrate that the increase in equivalence ratio decreases the production of NO_x in up to O(4). Clearly the reduction of oxygen is partially responsible of this shift, as less O_2 minimizes the complete reaction of ammonia and hydrogen. However, the results also provide evidence that ammonia based fuels can potentially be used under fuel rich conditions in order to decrease the production of nitrogen oxides. Moreover, it is clear that the increase in inlet temperature augments NO_x emissions in ~O(2). Initial attention was focused on the increase of flame

temperature, which boosts Zel'dovich NO_x production. Although the adiabatic temperatures rise from 2033 to 2185K between cases (i.e. $\phi = 1.0$ and $\phi = 1.2$), thus increasing Zel'dovich NO_x , the O(2) increase is also associated with chemical reactions occurring during combustion. As shown previously, OH radicals are compacted and concentrated at the flame front, an observation that will be discussed later.

Introduction of by-pass air maintained NO_x concentrations as the overall equivalence ratio fell to lean conditions. The explanation for this observation is based on the post-combustion reaction and recombination of hot, unburned ammonia with the extra oxygen provided by the bypass air in the post-combustion zone, thus posing a challenge for current gas turbine combustors where post-combustion dilution takes place. Further research [36] explores the concept, thus being left out of this work.

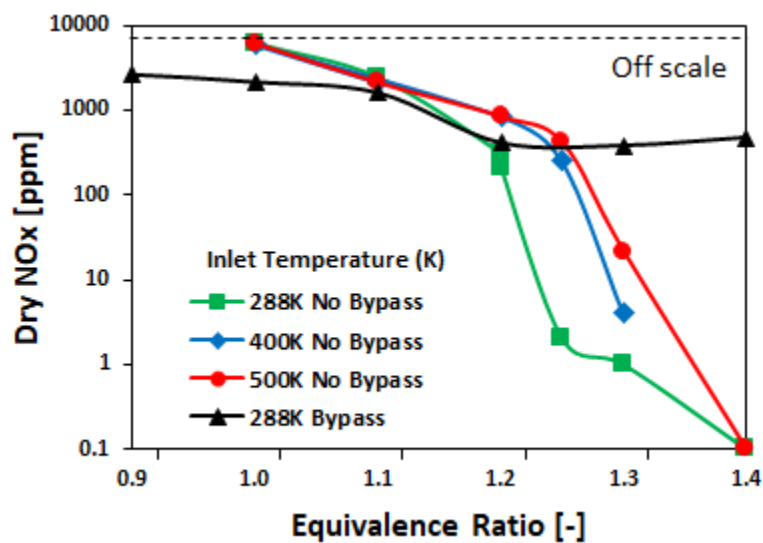

Fig. 7. NO_x emission. Bypass condition based on ϕ at the primary combustion zone. Results normalised to 15% O_2 .

3.2. Numerical results

The intermediate reaction kinetics at different inlet conditions were modelled, specifically targeting an equivalence ratio of 1.20, case 3 Table 1. It is observed that the consumption of ammonia mainly occurs due to its reaction with OH radicals through the reaction $\text{NH}_3 + \text{OH} \rightarrow \text{NH}_2 + \text{H}_2\text{O}$, followed by its reaction with other free radicals, i.e. H, O, etc. Although the change in temperature slightly alters the consumption of NH_3 through these reactions, Fig. 8, it is clear that the consumption of ammonia has increased O(4) at higher temperatures. This clearly correlates with the previous findings, Fig. 5, where OH radicals are shown to be more reactive at the flame front at higher inlet temperatures.

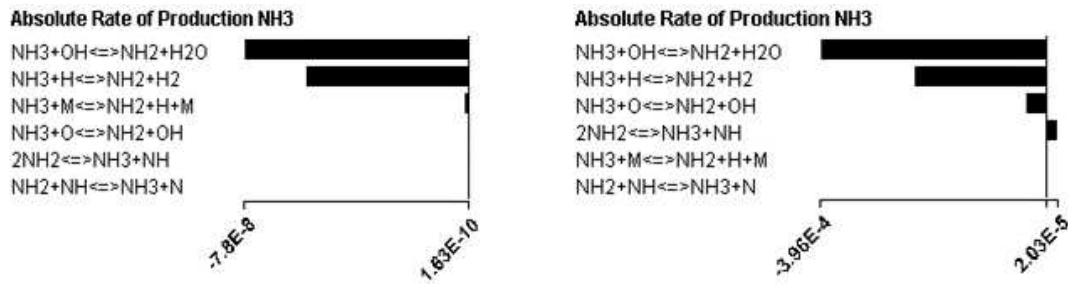

Fig. 8. Absolute rate of production of NH₃ at the flame at two different inlet temperatures. Left) 288K; right) 488K. Units [moles/cm³·s].

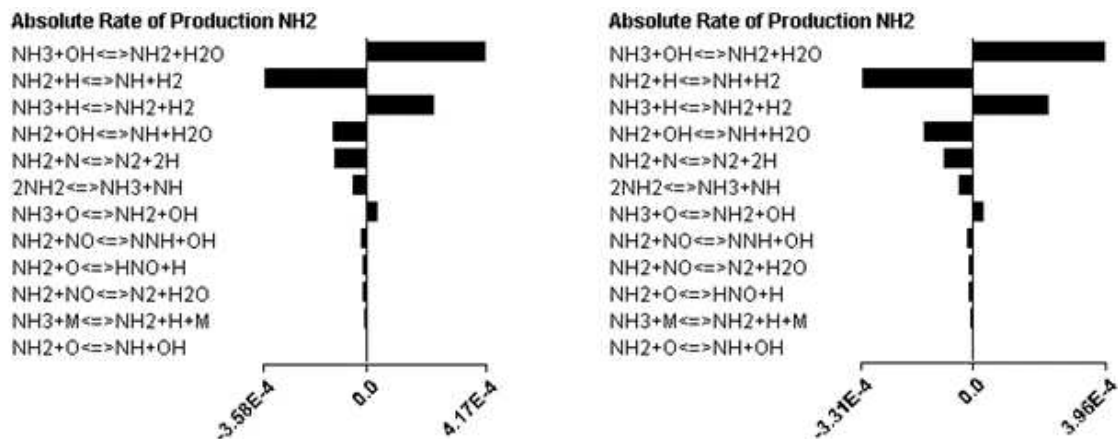

Fig. 9. Absolute rate of production of NH₂ at the flame at two different inlet temperatures. Left) 288K; right) 488K. Units [moles/cm³·s].

By contrast, NH₂, the first main radical product of ammonia consumption, seems to remain as reactive at elevated temperature as under atmospheric inlet temperature conditions, Fig. 9. The radical degrades into NH while producing additional water molecules. Interestingly, NO in the flame front starts reacting with the NH₂ radical through the reaction NH₂+NO \rightarrow N₂H+OH, thus slightly boosting the OH production, consistent with the still high OH intensity observed at high equivalence ratios, Fig. 4. Although relatively small compared to other reactions, NH₂+NO \rightarrow N₂+H₂O is still an important contributor at the flame front, Fig.9.

However, the trend is very different in the post-flame region, Fig. 10, where at high temperatures the remaining unburned ammonia and hot hydrogen react with OH and NH molecules, respectively, to produce NH₂ molecules which then interact with NO to form N₂H and N₂+H₂O, thus enhancing the reduction of nitric oxides. Therefore, the higher flame temperature allows better decomposition of unburned NH₃ into NH_x radicals with further recombination of species that will ensure that more NO is consumed, reducing this emission in the post-flame zone.

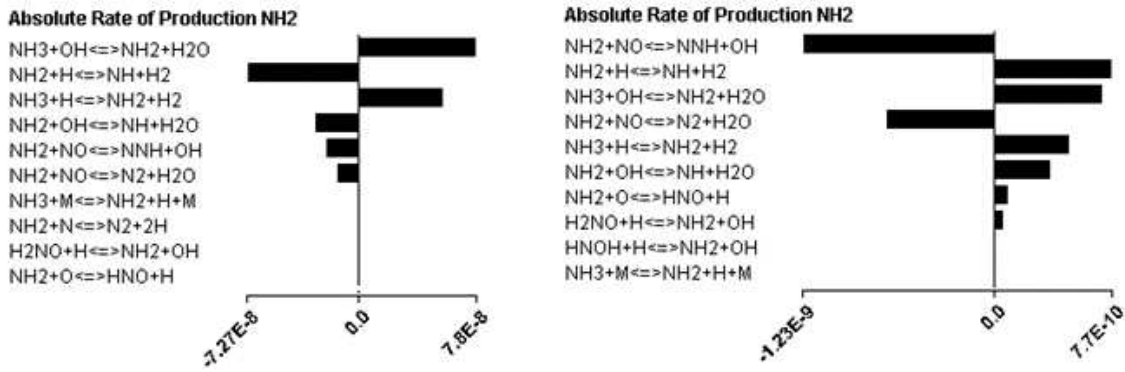

Fig. 10. Absolute rate of production of NH₂ in the Post-flame region at two different inlet temperatures.

Left) 288K; right) 488K. Units [moles/cm³·s].

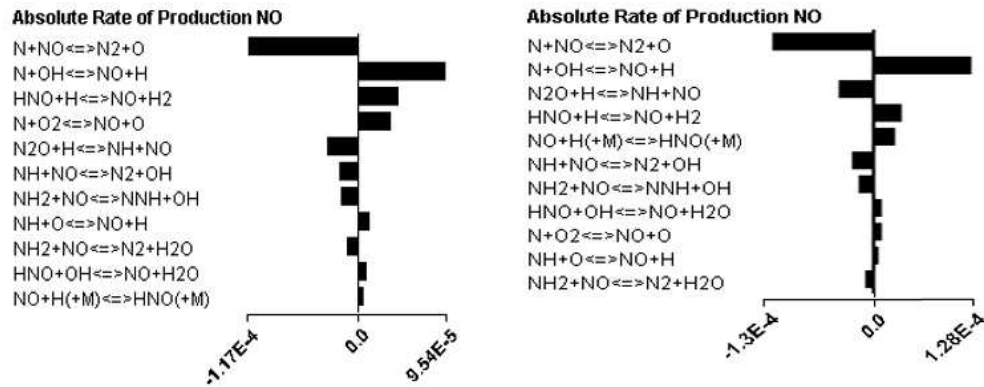

Fig. 11. Absolute rate of production of NO at the flame at two different inlet temperatures. Left) 288K;

right) 488K. Units [moles/cm³·s].

As for nitrogen-based emissions, NO production during the high temperature case is greater than during the tests carried out under ambient temperature, Fig. 11. The phenomenon is a consequence of the increased reactivity of nitrogen and hydroxyl radicals, $N+OH \rightarrow NO+H$, that not only are more energetic due to higher temperatures, but also are more abundant in the flow field, as denoted in Fig. 7, showing a greater production of nitrogen oxides via Zel'dovich reaction. On the other hand, the consumption of NO still occurs via recombination with N, NH and NH₂. Although reaction with N would be ideal to remove nitrogen oxide emissions from the flue gases, it is also observed that nitrogen in its atomic form is also a crucial contributor of NO production, as mentioned above. Simultaneously, OH presents an important contribution towards the production of NO, as discussed below.

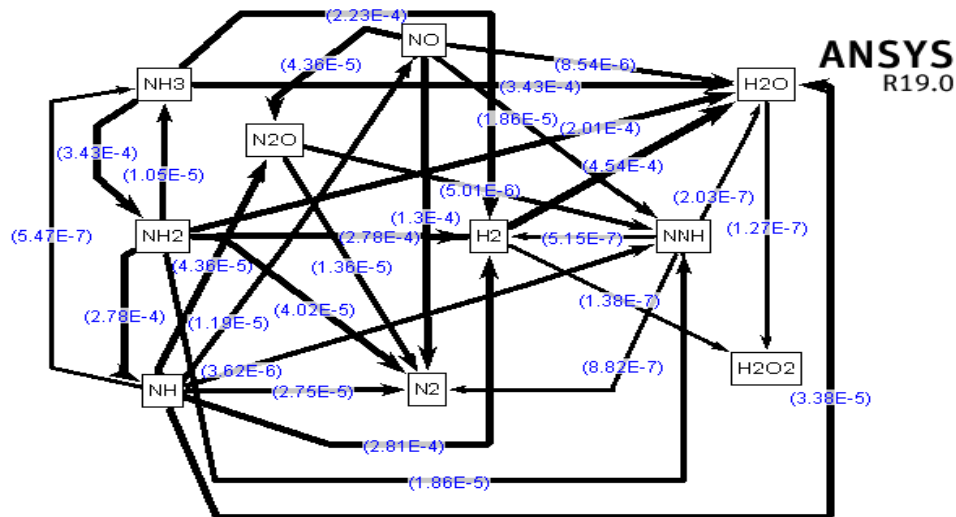

Fig. 12. Main reaction paths for most important species at a representative industrial inlet temperature, i.e. 567K, atmospheric pressure. Units [moles/cm³.s].

The main reaction path of the most important species was also analysed for the flame zone, Fig. 12. It is observed that once ammonia splits into NH₂ radicals, the latter tend to produce NH that will lead to NO (through the production of either HNO and/or N), N₂O, H₂O and other nitrogen based molecules. Since most NH₂ radicals have already reacted through the flame, i.e. as amidogen (NH₂) is highly reactive [37] and decays quickly into NH, Fig. 12, the consumption of NO_x pollutants is relatively low close to the flame, whereas its reaction with hot NH₂ radicals formed in the post-flame zone facilitates further decrease of nitric oxides. A look at the OH production near the flame and at the end of the post-combustion zone, Fig. 13, confirms this effect. Figure 13 denotes how the presence of unburned oxygen and remnants of hydrogen increase the production of OH close to the flame where NH_x radicals have been partially depleted, whereas OH that has been produced through the post-combustion process finds unburned ammonia producing NH_x radicals with their previously discussed impacts on NO.

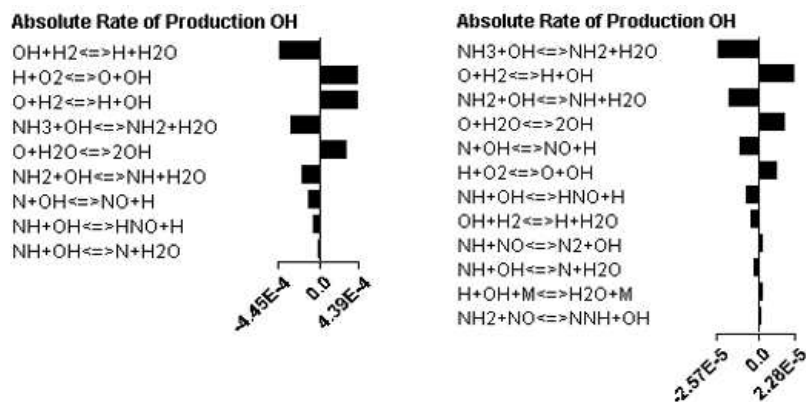

Fig. 13. Absolute rate of production of OH, 488K inlet temperature. Left) flame; right) post-combustion zone. Units [moles/cm³.s].

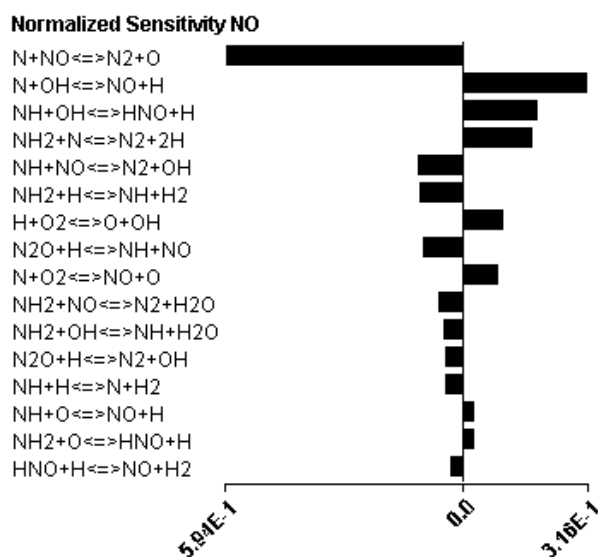

Fig. 14. Normalized sensitivity NO, 488K inlet temperature. Units [-].

The impact of these species towards the production of NO can be observed through the normalized sensitivity analysis of the molecule, Fig. 14. It is clear that the combination of OH species with other radicals tends to have a positive effect, while most of the NH_x reactions without OH (apart from NH_2+N) have a negative impact on the production of NO under rich fuel conditions at high temperature. Interestingly, the nitrogen radical N can also be another path towards the reduction of nitrogen oxides in these flames, as previously raised.

Progressing with the reaction of the blend and its formed radicals, combustion of this blend will lead either to the production of H_2O -that would enable pollutant-free combustion- or N_2O -a dangerous emission. However, further research is needed to ensure that mainly water vapour is produced. Thus, these results show some advantage of using quantities of small hot ammonia in the hot post-flame region to ensure further reduction of NO.

Therefore, one key finding is the enhancement of the reaction $NH_2+NO \rightarrow H_2O+N_2$ at rich conditions, which occurs when hot ammonia is present in the post-combustion zone without by-pass air at elevated inlet temperatures. This finding provides indications of how to re-design current injection systems, to ensure that NO_x emissions are minimized. The phenomenon is also linked to lower flame temperatures compared to those produced at stoichiometric conditions. The chemistry of the smaller amines, NH_2 and NH , at these temperatures is more uncertain; in particular the rate constants for the radical-radical reactions. At moderate temperatures below 1400 K, the fate of NH_2 largely determines the oxidation pathway of the ammonia as well as the reaction selectivity toward NO and N_2 . The key step in the production of NO are the fast $NH_x + OH$ reactions. The reactions with these molecules have been barely studied experimentally in the intermediate temperature range, and so their rate constants present significant uncertainties. The comparatively low temperatures utilised in previous studies [38], as well as the presence of NO, promote the reaction path $NH_3 \rightarrow NH_2 \rightarrow N_2$ (directly or via NNH), rather than

$\text{NH}_3 \rightarrow \text{NH}_2 \rightarrow \text{NH} \rightarrow \text{N}$, which is important at higher temperatures, thus supporting the reduction of emissions at lower temperatures expected in the post-combustion zone.

3.3. Cycle Analyses

The cycle was initially calibrated using experimental tests from the manufacturer [39]. Results showed good correlation between the numerical cycle and the manufacturer results, Fig. 15. The results show that the relative error for the power calculated by the mathematical model and the value of the real turbine was 0.22% while the relative error for the efficiency was 0.07%.

When the model was used to compare the efficiency of the ammonia/hydrogen cycle, first problem to solve was the power output at which the analysis needed to be performed. Due to the maximum permissible fuel flowrate of 0.367 kg/s, this value was set as inlet condition for the ammonia/hydrogen cycle. A rich fuel condition was predefined to ensure low NO_x emissions, as experimentally demonstrated, with a total air mass flowrate of 2.260 kg/s into the combustion chamber, setting the analysis at 1.20 equivalence ratio.

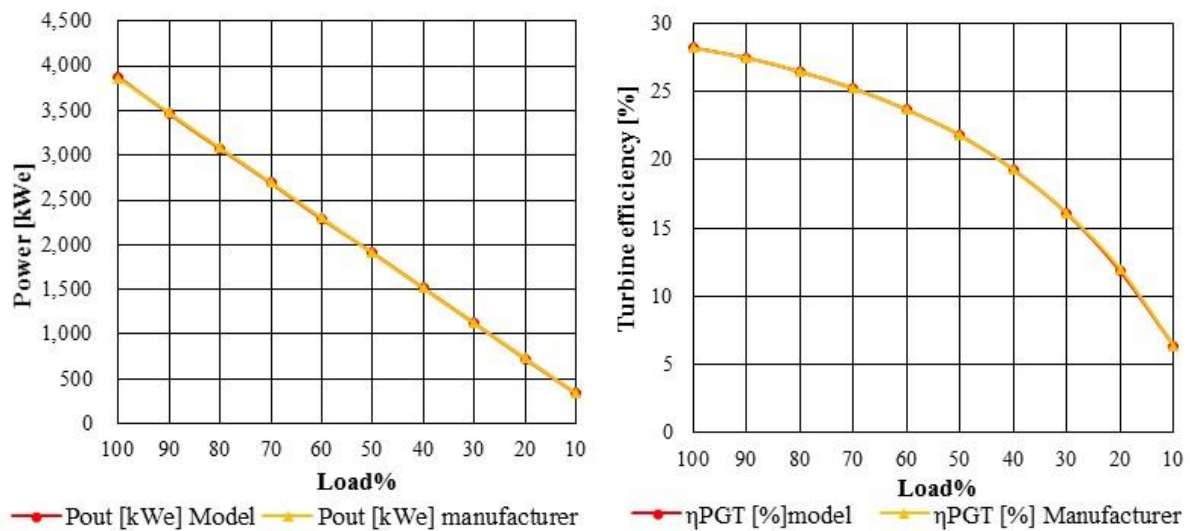

Fig 15. Correlation between the numerical model and an actual turbine using NG/air.

In order to compare such a system with current, high performance available technologies, a Dry Low NO_x (DLN) condition operating at $\phi=0.65$ using methane as fuel was employed for comparison purposes. Thus, with a total fuel mass flowrate of 0.207 kg/s and an air flowrate of 5.480 kg/s into the combustion chamber, analyses were performed. A total air mass flowrate from the compressor was set at 14.990 kg/s, with a thermal power of 10.37MW in both cases.

As expected, the reduced quantity of air (~15% of total air throughout) fed into the combustor for the ammonia/hydrogen blend, together with turbine inlet temperatures of only 850K - a consequence of the excessive dilution that occurs after the primary combustion zone product by the remaining air coming from the main compressor - led to a cycle efficiency of only ~ 9.77%. Results for the cycle including

the DLN methane-fuelled combustor, predict efficiencies of about 19.36%, i.e. since the system was designed to run at higher fuel flowrates, with air in the combustion primary zone accounting ~37% of the total available air flowrate, thus producing turbine inlet temperatures of 1155K.

Although it is clear that efficiencies can be increased by reducing dilution into the turbine, the model cannot be calibrated for these further calculations at this stage, and a new set of calibration data is required to enable calculations under these conditions. Moreover, it is evident from the previous analyses that although this particular ammonia/hydrogen blend has potential for low emissions combustion, generators running on these blends need to be re-designed to ensure that higher efficiencies through greater flue gas temperatures and/or mass flowrates are attained.

4. Conclusions

- This study shows that ammonia can be used as a fuel in gas turbines with stable combustion operation when hydrogen is added using a 70%NH₃-30%H₂ (mol%) blend. Results show that under rich conditions, OH* intensities are still high, along with an increase in the consumption of OH at the flame front at high inlet temperatures representative of real gas turbine conditions.
- Contraction of the flame under high inlet temperature conditions was evident, improving the combustion efficiency and leading to increased consumption of species at the flame boundaries.
- According to the calibrated numerical analyses, the process ensured that hot, unburned ammonia was available for further reaction with existing NO_x to decompose into NH_x radicals, reducing the pollutant to relatively low levels of NO_x emissions (<50 ppm). Atomic nitrogen can also be another method for NO reduction, although this can clash with its sensitivity to increase the pollutant in the presence of OH radicals.
- However, it is shown that operation of gas turbines adopting this blend and standard Brayton cycles produces low efficiencies that cannot compete with current DLN technologies. Further research and development is required to identify conditions enabling optimised operation using ammonia/hydrogen blends with low NO_x and higher cycle efficiency.

5. Acknowledges

Cardiff University gratefully acknowledges the support from the Welsh European Funding Office (WEFO) through its program “Flexible Integrated Energy Systems (FLEXIS)”, project no. 80835. Dr. Xiao would like to thank all the support given by the Chinese Scholarship Council (CSC) in order to complete his PhD studies at the UK.

6. References

- [1] Ritter SK. The Haber-Bosch Reaction: An Early Chemical Impact On Sustainability, C&EN Chemical and Engineering News 2008; 86(33).

- [2] Yapicioglu A, Dincer I. Performance assesment of hydrogen and ammonia combustion with various fuels for power generators. *International Journal of Hydrogen Energy* 2018, DOI: 10.1016/j.ijhydene.2018.08.198.
- [3] Verkamp FJ, Hardin M, Williams JR. Ammonia combustion properties and performance in gas turbine burners. *International Symposium of Combustion* 1967;11:985-92.
- [4] Pratt DT. Performance of ammonia fired gas turbine combustors. San Diego, USA: Report T-9-TS-67-5 Solar; 1967.
- [5] Newhall H, Starkman ES. Theoretical performance of ammonia as a gas turbine fuel. SAE Technical paper 1966, 660768.
- [6] Karabeyoglu A, Evans B. "Fuel conditioning system for ammonia fired power plants." 2012 [Online] Available: <https://nh3fuel.files.wordpress.com/2012/10/evans-brian.pdf> [Accessed 20 January 2017]
- [7] Karabeyoglu A, Evans B, Stevens J, Cantwell B. Development of ammonia based fuels for environmentally friendly power generation. 10th International Energy Conversion Engineering Conference Atlanta, USA, 2012.
- [8] Nozari H, Karaca G, Tuncer O, Karabeyoglu A. Porous medium based burner for efficient and clean combustion of ammonia-hydrogen-air systems. *International Journal of Hydrogen Energy* 2017;42(21): 14775-14785.
- [9] Kurata O, Iki N, Matsunuma T, Inoue T, Tsujimura T, Furutani H, et al. Performances and emission characteristics of NH₃-air and NH₃-CH₄-air combustion gas-turbine power generations. *Proceedings of the Combustion Institute*. 2017;36:3351-9.
- [10] Iki N, Kurata O, Matsunuma T, Inoue T. "Micro gas turbine operation with kerosene and ammonia", 2014. [Online]. Available: <https://nh3fuel.files.wordpress.com/2014/10/nh3fa-2014-norihiko-iki.pdf> [Accessed 1 November 2016].
- [11] Somarathne KDKA, Hatakeyama S, Hayakawa A, Kobayashi H. Numerical study of a low emission gas turbine like combustor for turbulent ammonia/air premixed swirl flames with a secondary air injection at high pressure. *International Journal of Hydrogen Energy*. 2017;42(44): 27388-27399.
- [12] Iki N, Kurata O, Matshunuma T, Inoue T, Tsujimura T, et al. Operation and flame observation of micro gas turbine firing ammonia. *Proceedings of the ASME Turbo Expo*, Charlotte, USA, 2017. Ref. GT2017-64250.
- [13] Xiao H, Howard M, Valera-Medina A, Dooley S, Bowen PJ. Study on Reduced Chemical Mechanisms of Ammonia/Methane Combustion under Gas Turbine Conditions. *Energy & Fuels*. 2016;30:8701-10.
- [14] Xiao H, Valera-Medina A, Marsh R, Bowen PJ. Numerical study assessing various ammonia/methane reaction models for use under gas turbine conditions. *Fuel* 2017; 196: 344-351.
- [15] Valera-Medina A, Marsh R, Runyon J, Pugh D, Beasley P, Hughes T, Bowen P. Ammonia-methane combustion in tangential swirl burners for gas turbine power generation. *Applied Energy* 2017;185:1362-71.
- [16] Jojka J, Slefarski R. Dimensionally reduced modeling of nitric oxide formation for premixed methane-air flames with ammonia content. *Fuel* 2018; 217:98-105.
- [17] Ito S, Kato S, Saito T, Fujimori T, Kobayashi H. "Development of ammonia / natural gas dual fuel gas turbine combustor," NH₃ Fuel Association, 2016. Available online: <https://nh3fuelassociation.org/2016/08/22/development-of-ammonia-natural-gas-dual-fuel-gas-turbine-combustor/> [2016-11-29].
- [18] Kurata O, Iki N, Inoue T, Matsunuma T, Tsujimura T, Furutani H, Kawano M, Arai K, Okafor EC, Hayakawa A, Kobayashi H. Development of a wide range-operable, rich-lean low-NO_x combustor for NH₃ fuel gas-turbine power generation. *Proc Combustion Symposium* 2018 (37), DOI: 10.1016/j.proci.2018.09.012.
- [19] Xiao H, Valera-Medina A. Chemical kinetic mechanism study on premixed combustion of ammonia/hydrogen fuels for gas turbine use. *J Eng Gas Turbines Power* 2017; doi: 10.1115/1.4035911.

- [20] Valera-Medina A, Pugh DG, Marsh R, Bulat G, Bowen P, Preliminary study on lean premixed combustion of ammonia-hydrogen for swirling gas turbine combustors. *International Journal of Hydrogen Energy* 2017;42(38):24495-24503.
- [21] ISPT. "Nuon turns Magnum-plant into a sustainable super battery". Eemshaven, The Netherlands: ISPT; 2016.
- [22] Proton Ventures, "Decentralised ammonia production in the Netherlands". NH3 Fuel Association, 2016. Available online: <https://nh3fuel.files.wordpress.com/2016/09/hans-vrijenhoef-decentralised-ammonia-production-in-the-netherlands-nh3fa2016.pdf> [2016-11-30].
- [23] Brown T. "Chugoku Electric Completes Successful Trial, Seeks Patent for Ammonia Co-Firing Technology". Ammonia Energy, 2017. Available online: <http://www.ammoniaenergy.org/chugoku-electric-seeks-patent-for-ammonia-co-firing-technology/> [2017-11-15]
- [24] IHI. "Demonstrate the world's highest level of ammonia co-firing in coal-fired power plant test burning equipment - Contributing to reduce CO2 emissions Development of combustion technology enabling the use of ammonia fuel". IHI, 2018. Available online: https://www.ihico.jp/ihico/all_news/2017/technology/2018-3-28/index.html [2018-04-20]
- [25] Rutar T, Malte PC, NOx formation in high-pressure jet-stirred reactors with significance to lean-premixed combustion turbines, ASME Turbo Expo 2001: Power for Land, Sea, and Air. American Society of Mechanical Engineers, 2001: V002T02A034-V002T02A034.
- [26] Fichet V, Kanniche M, Plion P, Gicquel O. A reactor network model for predicting NOx emissions in gas turbines *Fuel* 2010;89(9):2202-2210.
- [27] Syred N. A review of oscillation mechanisms and the role of the precessing vortex core (PVC) in Swirl Combustion systems, *Progress Energy and Combustion Science* 2006;32:93-161.
- [28] Valera-Medina A, Syred N, Bowen P. Central recirculation zone visualization in confined swirl combustors for terrestrial energy, *Journal AIAA Propulsion and Power* 2013;29(1):195-204.
- [29] Mathieu O, Petersen EL. Experimental and modeling study on the high-temperature oxidation of Ammonia and related NOx chemistry, *Combustion and Flame* 2015;162:554-570.
- [30] Xiao H, Valera-Medina A, Bowen P, Gas Turbine Combustion Simulations using an Improved Reaction Model for Ammonia/Hydrogen Fuels, *Energy and Fuels* 2017;31(8): 8631-8642.
- [31] Mendiara T, Glarborg P, Ammonia chemistry in oxy-fuel combustion of methane. *Combustion and Flame* 2009; 156(10):1937-1949.
- [32] Tian Z, Li Y, Zhang L, Glarborg P, Qi F, An experimental and kinetic modeling study of premixed NH3/CH4/O2/Ar flames at low pressure. *Combustion and Flame* 2009;156(7):1413-1426.
- [33] Konnov AA, Implementation of the NCN pathway of prompt-NO formation in the detailed reaction mechanism. *Combustion and Flame* 2009;156(11):2093-2105.
- [34] Duynslaegher C, Contino F, Vandooren J, Jeanmart H, Modeling of ammonia combustion at low pressure. *Combustion and Flame* 2012;159(9):2799-2805.
- [35] Al-Doboon A, Gutesa M, Valera-Medina A, Syred N, Ng JH, Chong CT, CO2-argon-steam oxy-fuel (CARSOXY) combustion for CCS inert gas atmospheres in gas turbines, *Applied Thermal Engineering* 2017;122:350-358.
- [36] Pugh D, Bowen P, Valera-Medina A, Giles A, Runyon J, Marsh R. Influence of steam addition and elevated ambient conditions on NOx reduction in a staged premixed swirling NH3/H2 flame. *Proc Combustion Symposium* (37). DOI: 10.1016/j.proci.2018.07.091.
- [37] Crowley JN, Sodeau JR, Reaction between Nitric Oxide and Amidogen Radical NH2, *Journal of Physical Chemistry* 1987;91:2024-2026.
- [38] Skreiberg Ø, Kilpinen P, Glarborg P. Ammonia chemistry below 1400 K under fuel-rich conditions in a flow reactor. *Combustion and Flame* 2004;136:501-18.

[39] Centrax, 2012, Technical Description, CX501-KB5 Generator Sets.