

Article

Analysis of Gaseous By-Products of CF₃I and CF₃I-CO₂ after High Voltage Arcing Using a GCMS

Phillip Widger *  and Abderrahmane (Manu) Haddad

Advanced High Voltage Engineering Research Centre, School of Engineering, Cardiff University, The Parade, Cardiff CF24 3AA, UK; haddad@cardiff.ac.uk

* Correspondence: widgerp@cardiff.ac.uk; Tel.: +44-2920-875125

Received: 26 March 2019; Accepted: 20 April 2019; Published: 23 April 2019



Abstract: Increasing demand for an alternative insulation medium to sulphur hexafluoride (SF₆) has led to the investigation of new environmentally friendly insulation gases which could be used in high voltage equipment on the electrical power network. One such alternative, which is currently being explored by researchers, is Trifluoroiodomethane (CF₃I) which could potentially be used in a gas mixture with carbon dioxide (CO₂) as an insulation medium. In this paper an analysis of gaseous by-products detected as a result of high voltage breakdown through pure CF₃I and a CF₃I-CO₂ gas mixture across a sphere-sphere electrode arrangement is given. Gas chromatography and mass spectrometry (GCMS) is used to identify the gaseous by-products produced as a result of high voltage arcing which causes the gas between the electrodes to dissociate. Analysing these gas by-products helps to identify the long-term behaviour of the gas mixture in high voltage equipment.

Keywords: Trifluoroiodomethane (CF₃I); Sulphur Hexafluoride (SF₆); High Voltage Gas Insulation; Gas Insulated Lines (GIL); Gas Insulated Switchgear (GIS)

1. Introduction

In the power industry, sulphur hexafluoride (SF₆) is increasingly being used as a high voltage insulation medium in gas insulated lines (GIL) for power transmission purposes and in gas insulated switchgear (GIS) as an insulating and arc interrupting medium [1]. However, the use of SF₆ is receiving a lot of scrutiny from the international community as a gas of extremely high global warming potential (GWP) which is estimated to be 23,500 times that of CO₂ [2] when released into the atmosphere. SF₆ is an extremely damaging global warming gas with a long atmospheric lifetime of 3200 years [3].

At present the international scientific community is searching for an alternative insulation medium which has all the necessary qualities required for use in the power industry, similar to SF₆, without the damaging environmental effects. At present the candidates being proposed include: Fluoronitrile [4], Fluoroketones [5], Hydrofluoroolefins HFO's [6] and Trifluoroiodomethane (CF₃I) [7–9] all of which exhibit a lower global warming potential than SF₆ and a reduced atmospheric lifetime. However, there are still concerns regarding their toxicity and much research is still needed to evaluate their characteristics in full [10–12]. In the power industry, at high voltages of 11 kV and above, SF₆ gas insulated equipment is used in GIS and GIL. Long term partial arcing or full HV breakdowns to ground, in this gas insulated equipment, release large amounts of energy through the insulation gas, which leads to the gas dissociating. This irrevocable gas dissociation can affect the overall insulation strength and operational withstand level of the HV equipment. As such, these events are of real concern to the long-term operation of future alternatively insulated gas equipment. It is important to understand the effect this may have on the gas being used to insulate equipment and whether the gaseous by-products will affect the ability of the equipment to operate safely or pose future health or environmental problems. In this paper the by-products produced from the use of a CF₃I-CO₂ gas

mixtures are analysed when a high voltage breakdown event is intentionally used to age the insulation gas. In order to fully analyse the behaviour of a $\text{CF}_3\text{I}-\text{CO}_2$ gas mixture, the results have been compared to that of the same practical test undertaken with pure CF_3I and pure CO_2 in order to understand how a gas mixture develops by-products compared to its pure counterparts.

2. Results

2.1. Results of Pure CO_2 Gas By-Product Analysis

The typical breakdown voltage and current level used during the practical testing of the pure CO_2 sphere-sphere gas gap was approximately 33 kV (peak) and 30 A. An initial gas sample (before HV arcing) is shown in Figure 1. Following 100 breakdowns across the sphere-sphere electrode gas gap, the resulting gas analysis can be shown in Figure 1 along with the original gas sample shown in the same figure for comparison. It can be shown from this figure that after the 100 arcing events, from the energy level available from this transformer, that the CO_2 molecule is either remaining in the same form or producing solid carbon deposits with a gaseous CO/O_2 by-product but it is difficult to show this as CO/O_2 exists in the original samples. No other by-products are detected in a quantity that would allow for the GCMS to conclusively prove their existence. It can be noted that CO_2 , as a relatively simple molecule, remains largely unchanged by the breakdown phenomena it is subjected and therefore can be considered a good choice as a buffer gas for use in insulation gas mixtures.

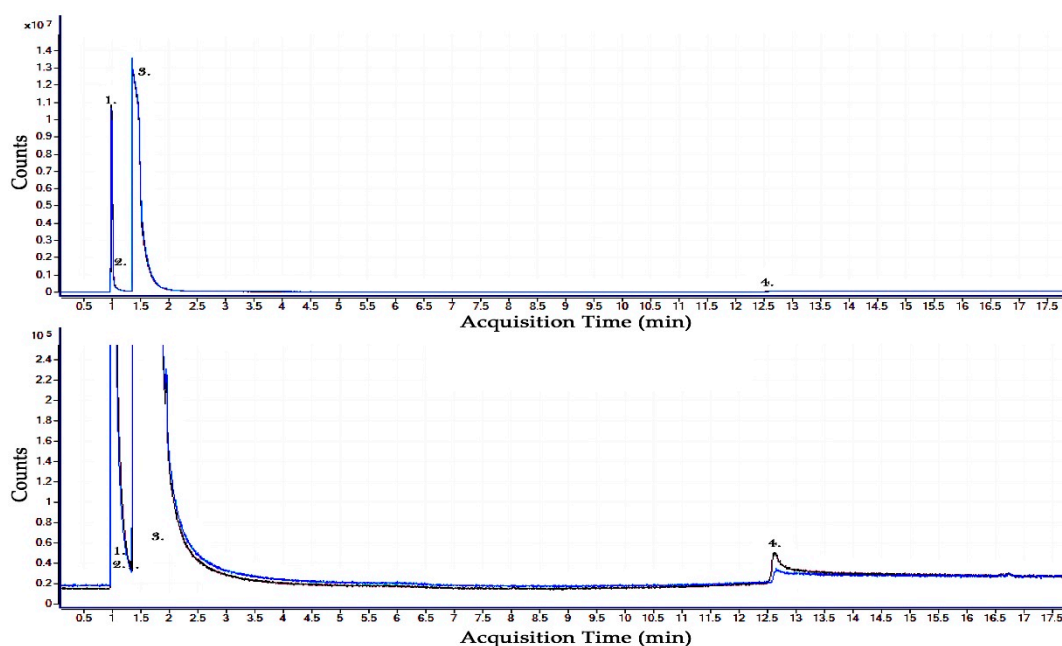

Figure 1. GCMS Analysis of the gaseous by-products of CO_2 , purple—gas sample taken before breakdown, blue—gas sample taken following 100 high voltage AC breakdowns. Detected gaseous molecules: 1. CO —Carbon Monoxide, 2. O_2 —Oxygen, 3. CO_2 —Carbon Dioxide, 4. H_2O —Water.

2.2. Results of Pure CF_3I Gas By-Product Analysis

Next a pure gas sample of CF_3I is analysed using the GCMS to compare gas samples both before and after 100 breakdowns across a sphere-sphere gas gap. It can be noted that even after 15 different flushing cycles of the test arrangement and gas sampling system with Helium that residual CO_2 is still detected by the GCMS due to its level of sensitivity, which is necessary because of the amount of by-products produced. It can also be noted that CHF_3 , C_2HF_5 and H_2O are also present in the pure gas before any breakdown takes place, indicating that these slight impurities exist in the original gas sample or that the gas is reacting with one or more of the storage/test vessel materials. H_2O likely

exists in small quantities due to the fact that the level of vacuum used, which is the normal level for gas insulated power equipment, is insufficient to remove all of the H₂O from the pressure vessel materials.

Following 100 breakdown events it can be shown in Figure 2 that the original gas impurities/by-products remain along with newly created gaseous by-products, detected only after the 100 breakdown events. These detected by-products of pure CF₃I include: CF₄, C₂F₆, C₂F₄, C₃F₈, C₃F₆ or C₄F₈, C₂F₅I, C₃F₇I and C₃F₇IO. It is likely that C₃F₇IO is a by-product caused by the interaction of CF₃I and the very small quantities of CO₂ that remain or the H₂O content which is also present before the breakdown sample is taken. It can be noted that because the molecular weight of iodine is much heavier and larger than the other elements that make up the molecule CF₃I, that all large molecular by-products that contain iodine have a longer retention time from this column than CF₃I and the by-products that do not contain iodine have a shorter retention time along this column and are detected near the front end of each run. It is also possible that there are by-products which have the same retention time in this column as CF₃I and therefore are not able to be distinguished from CF₃I. It can be shown in Figure 2 that the large amount of CF₃I in the gas sample takes approx. 2 min to pass the detector.

It is also possible to show that most of these by-products detected after 100 breakdowns are similar to the by-products detected in pure CF₃I when subjected to PD events as described by M. Kamarol, Y. Nakayama, T. Hara, S. Ohtsuka and M. Hikita in reference [13]. This means that the breakdown event method used in this paper and the partial discharge method used in reference [13] are comparable methods of determining both the long term and short-term arcing by-products of CF₃I.

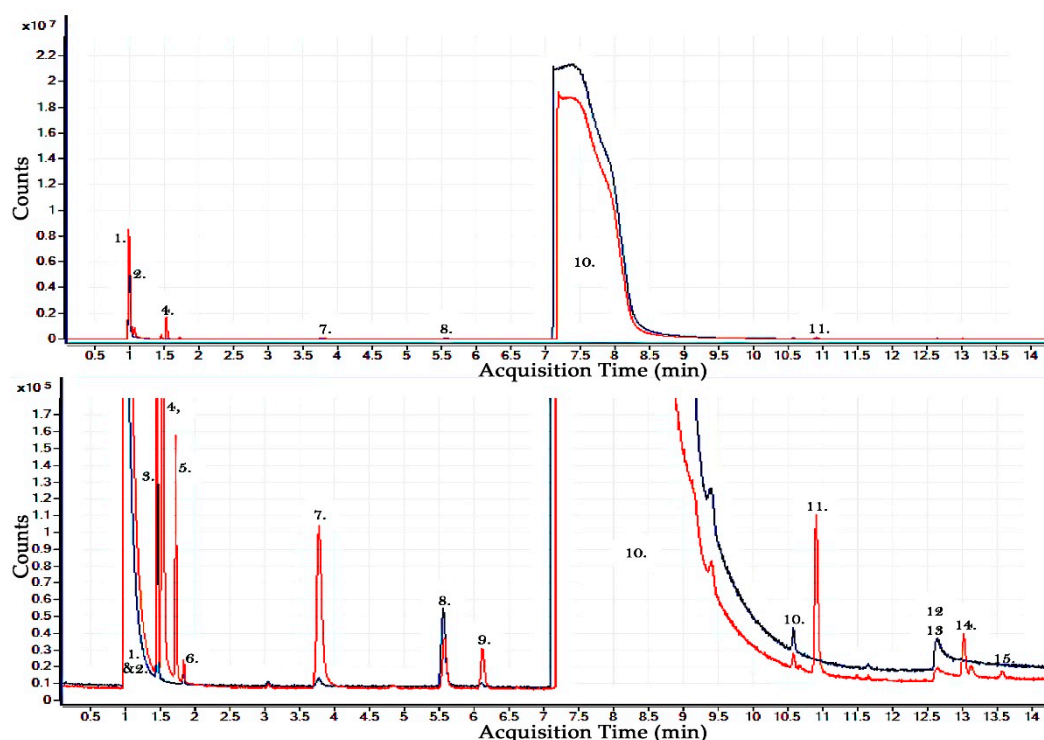

Figure 2. GCMS Analysis of the gaseous by-products of pure CF₃I, blue—gas sample before breakdown, red—gas sample following 100 high voltage AC breakdowns. Detected before breakdown: 1. CO—Carbon Monoxide, 3. CO₂—Carbon Dioxide, 6. CHF₃—Fluoroform, 8. C₂HF₅—Ethane, pentafluoro-, 10. CF₃I—Methane, trifluoroiodo-, 12. I₂—Iodine, 13. H₂O—Water. Detected after breakdown only: 2. CF₄—Tetrafluoromethane, 4. C₂F₆—Ethane, hexafluoro-, 5. C₂F₄—Ethene, tetrafluoro-, 7. C₃F₈—Perfluoropropane, 9. C₃F₆—Propene, hexafluoro- or C₄F₈—Cyclobutane, octafluoro-, 11. C₂F₅I—Pentfluoroethyl iodide, 14. C₃F₇I—Perfluoropropyl iodide, 15. C₃F₇IO—Tetrafluoro-1 trifluoromethoxy 1-iodoethane.

2.3. Results of 30:70% CF₃I-CO₂ Gas By-Product Analysis

Following the tests carried out with pure CF₃I, a pressure-pressure gas mixture ratio of 30% CF₃I and 70% CO₂ was examined to show the by-products produced by this gas mixture using the same sphere-sphere test electrode arrangement. It can be shown that, before any breakdown event takes place, the 70% CO₂ is detected in the gas sample as well as a CO component. Before breakdown, the 30% CF₃I component of the gas mixture is detected along with a long 2 min retention time, as well as components such as CHF₃ and C₂HF₅. A small amount of H₂O is also detected before any breakdown event is undertaken, presumably retained during vacuum from the containing vessel wall materials.

After 100 breakdown events have been carried out across the sphere-sphere electrode gas gap containing 30:70% CF₃I-CO₂, a gas sample was taken and the results were analysed using the GCMS as shown in Figure 3. The results show that C₂F₆O₃—Trioxide, bis(trifluoromethyl), C₂F₆—Ethane, hexafluoro-, C₃F₈—Perfluoropropane and CF₄—Tetrafluoromethane were detected as by-products from the 30:70% CF₃I-CO₂ gas mixture. It is also likely that C₂H₃F₃—Ethane, 1,1,1-trifluoro- and C₂F₅I—Pentafluoroethyl iodide or C₂F₉I—Tetrafluoro(pentafluoroethyl)iodine could also be by-products but these are more difficult to confirm. It should also be noted that C₂HF₅—Ethane, pentafluoro- and CHF₃—Fluoroform were also detected before and after breakdown of this CF₃I-CO₂ gas mixture was carried out so they could be potential by-products, however, it is difficult to confirm they are produced as part of the arcing breakdown event and are not merely a by-product of gas interaction with containment materials. More analysis of this result, when compared to pure CF₃I, is given in the next section of this paper.

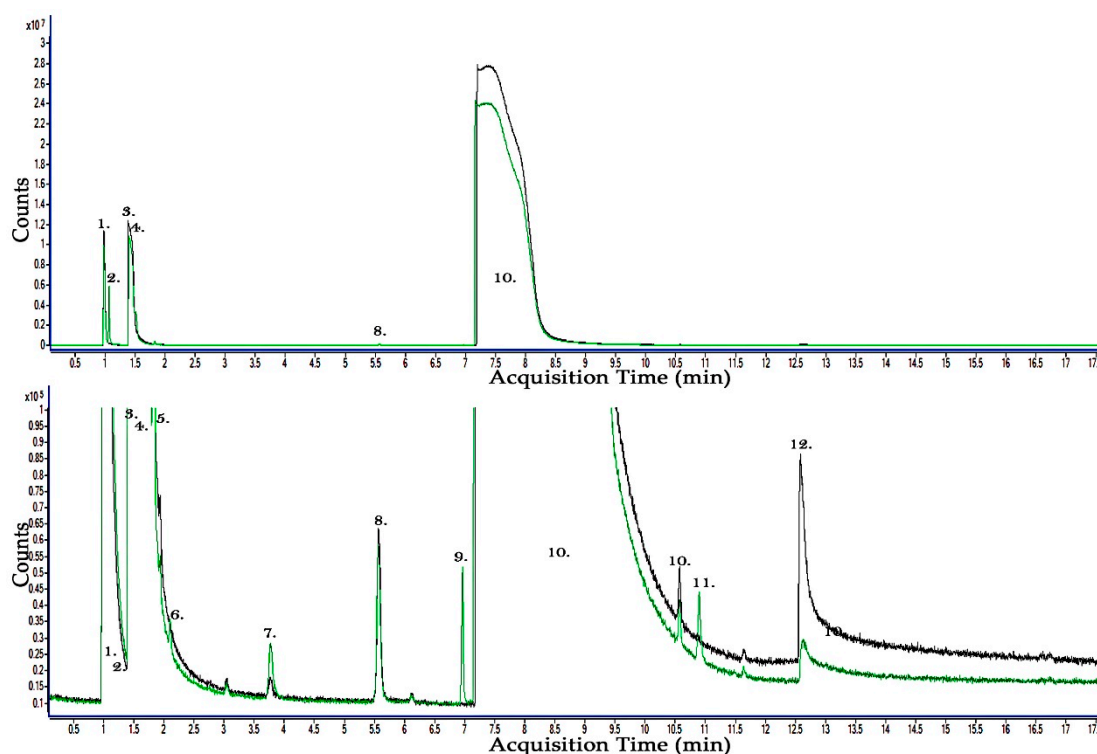

Figure 3. GCMS Analysis of the gaseous by-products of a 30%:70% CF₃I-CO₂ gas mixture, black line—gas sample before breakdown, green line—gas sample following 100 high voltage AC breakdowns. Detected before breakdown: 1. CO—Carbon Monoxide, 3. CO₂—Carbon Dioxide, 5. CHF₃—Fluoroform, 8. C₂HF₅—Ethane, pentafluoro-, 10. CF₃I—Methane, trifluoroiodo-, 12. H₂O—Water. Detected after breakdown only: 2. C₂F₆O₃—Trioxide, bis(trifluoromethyl) or CF₄—Tetrafluoromethane, 4. C₂F₆—Ethane, hexafluoro-, 6. C₂F₆O₃—Trioxide, bis(trifluoromethyl), 7. C₃F₈—Perfluoropropane, 9. CF₄—Tetrafluoromethane or C₂F₆O₃—Trioxide, bis(trifluoromethyl) or C₂H₃F₃—Ethane, 1,1,1-trifluoro-, 11. C₂F₅I—Pentafluoroethyl iodide or C₂F₉I—Tetrafluoro(pentafluoroethyl)iodine.

3. Discussion

3.1. Discussion of Pure CF_3I and 30:70% CF_3I-CO_2 Gas By-Product Comparison

In order to determine which by-products are produced after 100 breakdown events, it is important to examine the pure gases separately and compare these results to the gas mixture result. To identify which by-products are a result of the interaction between the two molecules in the gas mixture, it is useful to compare the analysis of all of these gas samples together i.e. both pure and mixtures. Figure 4 shows the GCMS analysis from both the pure CF_3I and the 30%:70% CF_3I-CO_2 gas mixture results. As pure CO_2 does not show any pertinent distinguishable results it was not necessary to include it in this discussion. The molecules and by-products detected during the GCMS analysis carried out in Figure 4 are shown in Table 1.

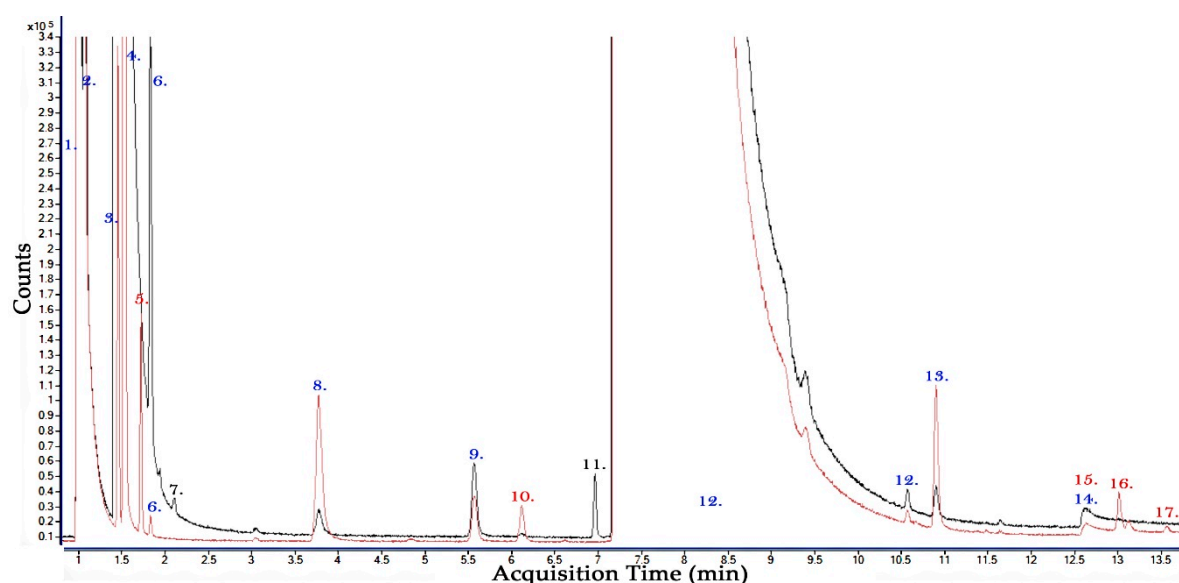

Figure 4. GCMS analysis of the gaseous by-products of a pure CF_3I and a 30%:70% CF_3I-CO_2 gas mixture, red line—pure CF_3I following 100 high voltage AC breakdowns, black line—30%:70% CF_3I-CO_2 gas sample following 100 high voltage AC breakdowns. (Blue numbers—detected molecule in both CF_3I and CF_3I-CO_2 breakdown tests, Red numbers—detected molecules in pure CF_3I breakdown test only, Black numbered molecules—detected in CF_3I-CO_2 breakdown test only) (Analysis of molecule numbers shown in Table 1).

Using the analysis conducted with both pure CF_3I and CF_3I-CO_2 it is possible to identify the by-products that are produced by the CF_3I component and the alternative/extra by-products that are produced when it is used in a gas mixture with CO_2 .

It can be shown that prior to the breakdown tests being carried out, in both the pure CF_3I and CF_3I-CO_2 gas samples, that both CHF_3 and C_2HF_3 are detected. This means that these are either impurities in the original gas sample or are a result of interaction with storage/test vessel materials. It is also possible that CHF_3 and C_2HF_3 could be produced as a result of the breakdown arcing tests carried out, however, it is not possible to distinguish these since they are present in the pre-breakdown gas analysis sample.

From both the pure CF_3I and CF_3I-CO_2 breakdown tests it can be shown that CF_4 , C_2F_6 , C_3F_8 and C_2F_5I are produced as gaseous by-products. As these by-products are produced in both tests, this means it is most likely that these by-products are a result of the CF_3I molecules in the gas mixture only and are not due to any interaction with the CO_2 in the gas mixture during the arcing event. It is also possible to surmise from this that because the CF_3I is only 30% of the partial pressure mixture with CO_2 that

the amount of these gaseous by-products will reduce as the amount of CF₃I gas molecules involved in the arcing event is reduced, however, more research is needed to conclusively prove this.

Table 1. GCMS analysis of the gaseous by-products of pure CF₃I and a 30%:70% CF₃I-CO₂ gas mixture.

By-product Labelled Number in Figure 4	CF ₃ I and CF ₃ I-CO ₂ Gas Sample—Detected before Breakdown	CF ₃ I and CF ₃ I-CO ₂ Gas Sample—By-products Detected after Breakdown	CF ₃ I Gas Sample only—By-products Detected after Breakdown	CF ₃ I-CO ₂ Gas Sample only—By-products Detected after Breakdown
1	CO—Carbon Monoxide			
2		CF ₄ —Tetrafluoromethane		CF ₄ or C ₂ F ₆ O ₃ —Trioxide, bis(trifluoromethyl)
3	CO ₂ —Carbon Dioxide			
4		C ₂ F ₆ —Ethane, hexafluoro-		
5			C ₂ F ₄ —Ethene, tetrafluoro-	
6	CHF ₃ —Fluoroform			
7				C ₂ F ₆ O ₃ —Trioxide, bis(trifluoromethyl)
8		C ₃ F ₈ —Perfluoropropane		
9	C ₂ HF ₅ —Ethane, pentafluoro			
10			C ₃ F ₆ or C ₄ F ₈ —Cyclobutane, octafluoro-	
11				C ₂ F ₆ O ₃ or C ₂ H ₃ F ₃ —Ethane, 1,1,1-trifluoro-
12	CF ₃ I—Methane, trifluoroiodo-			
13		C ₂ F ₅ I—Pentfluoroethyl iodide		C ₂ F ₅ I or C ₂ F ₉ I—Tetrafluoro (pentafluoroethyl)iodine
14	H ₂ O—Water			
15	I ₂ —Iodine (CF ₃ I test only)			
16			C ₃ F ₇ I—Perfluoropropyl iodide	
17			C ₃ F ₇ IO—Tetrafluoro-1 trifluoromethoxy 1-iodoethane	

In the pure CF₃I breakdown tests, the gas analysis showed additional by-products of C₂F₄, C₃F₆, C₃F₇I, C₃F₇IO and potentially C₄F₈ which were not identified in the CF₃I-CO₂ gas mixture breakdown tests. This means that these by-products are either not produced with a mixture of CF₃I and CO₂ or their production is reduced in quantity so that they are not detectable by the GCMS when CF₃I is mixed with CO₂ in a partial pressure mixture of 30% or less after 100 breakdown events.

In the GCMS analysis of the CF₃I-CO₂ gas mixture after breakdown it is identified that additional by-products of C₂F₆O₃ and potentially C₂H₃F₃ and C₂F₉I are produced which are not detected in the analysis of pure CF₃I after breakdown. These by-products are produced as a direct result of the interaction between CF₃I and CO₂ when used as a mixture which is subjected to arcing events of this

energy level and are not produced when both CF_3I or CO_2 are used as an insulation/interruption medium which undergoes separate arcing events.

3.2. Discussion of 30:70% CF_3I - CO_2 GCMS Column Comparison

A brief comparison for this paper was also conducted using two different GCMS columns. In Figure 5a the plot shows the gas chromatogram analysed by using a SiliPlot Column (Agilent, Amstelveen, Netherlands). In Figure 5b the plot shows the gas chromatogram analysed using a GS-GasPro Column (Agilent, Santa Clara, CA, USA). Although these two separate gas samples were analysed using different columns under relatively similar breakdown conditions to a 30%–70% CF_3I - CO_2 gas mixture some conclusions can be drawn about the use of these columns under this testing regime.

It can be shown from Figure 5 that at the front end of the run light gases such as CO and CO_2 are easier to distinguish using a GS-GasPro column as the separation of the column allows for individual identification which is not possible in the SilicaPlot column. It can also be shown that a gas with elution time similar to that of CF_3I such as CF_4 (No. 9. In Figure 5b) might also be harder to distinguish because these gases elute together and due to the high concentration of CF_3I it is harder to distinguish CF_4 at this retention time. It was therefore chosen to carry out all of the tests in the above sections using the GCMS with the GS-GasPro column.

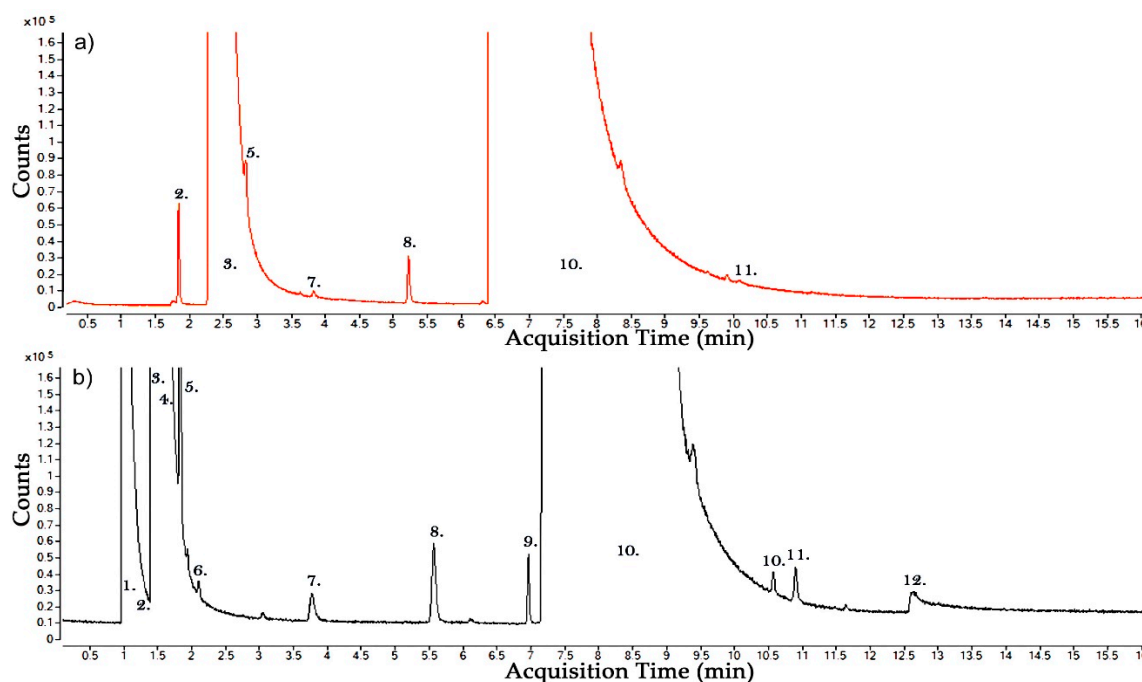

Figure 5. GCMS Analysis of the gaseous by-products of a 30:70% CF_3I - CO_2 gas mixture, (a) Orange line—gas analysis using a SilicaPlot column, (b) Black line—gas analysis using a GS GasPro column. 1. CO —Carbon Monoxide, 3. CO_2 —Carbon Dioxide, 5. CHF_3 —Fluoroform, 8. C_2HF_5 —Ethane, pentafluoro-, 10. CF_3I —Methane, trifluoroiodo-, 12. H_2O —Water, 2. $\text{C}_2\text{F}_6\text{O}_3$ —Trioxide, bis(trifluoromethyl) or CF_4 —Tetrafluoromethane, 4. C_2F_6 —Ethane, hexafluoro-, 6. $\text{C}_2\text{F}_6\text{O}_3$ —Trioxide, bis(trifluoromethyl), 7. C_3F_8 —Perfluoropropane, 9. CF_4 —Tetrafluoromethane or $\text{C}_2\text{F}_6\text{O}_3$ —Trioxide, bis(trifluoromethyl) or $\text{C}_2\text{H}_3\text{F}_3$ —Ethane, 1,1,1-trifluoro-, 11. $\text{C}_2\text{F}_5\text{I}$ —Pentafluoroethyl iodide or $\text{C}_2\text{F}_9\text{I}$ —Tetrafluoro(pentafluoroethyl)iodine.

4. Materials and Methods

In this paper the test electrode setup was fixed as shown in Figure 6. In this setup the electrodes were of sphere-sphere geometry with a diameter of 25 mm and manufactured from stainless steel 304 which is composed of the primarily alloys: iron (Fe), Chromium (Cr) and Nickel (Ni) and various other

trace elements [14]. Stainless steel 304 has a melting point of 1450 °C [14] so can only play a role in the decomposition products if the temperature in the arc reaches above this. These sphere electrodes are insulated using pure CO₂, CF₃I gas or a 30%:70% CF₃I-CO₂ gas mixture at a total pressure of 1.2 bar (g) which is contained within a pressurised tube and filled using stainless steel gas connectors. This insulated tube is connected to a high voltage bushing which is air insulated on one side and insulated by CO₂ at 2 bar (g) on the inside. This CO₂, which insulates the bushing, also surrounds the pressurised tube vessel containing the gas/gas mixture under test therefore keeping the test gas contained under a high pressure differential. This differential pressure eliminates any potential leakage as any leakage is more likely to occur from the CO₂ vessel inwards rather than the CF₃I gas tube outwards. The gases used have a purity level of >99.9% for CF₃I [15] and 99.8% for CO₂ [16]. The vessel containing CF₃I is electrically isolated from the main vessel. The ground electrode for the CF₃I vessel is connected via a dedicated grounding earth connection which is isolated from the outside pressure vessel walls, therefore ensuring the voltage and current measurements are separate from any external effects on the main vessel.

The gas mixture 30%–70% CF₃I-CO₂ was chosen to be analysed based on extensive research of the various characteristics of this gas mixture including electrical. In reference [9] the electrical characteristics of 10%–90%, 20%–80% and 30%–70% are discussed and it was found that 30%–70% had the best electrical performance. Another factor that greatly impacts the decision to use this gas mixture is the boiling point of this mixture which are limited by the restraints and specifications for indoor/outdoor high voltage electrical switchgear which states the operating temperatures of the equipment in the UK/Europe. 30%–70% CF₃I-CO₂ has a boiling point of –12.5 °C at a pressure of 0.5 MPa [17], while a higher percentage concentration of CF₃I in the gas mixture would fall outside the guided operating temperatures for gas insulated switchgear specifications at this common operating pressure.

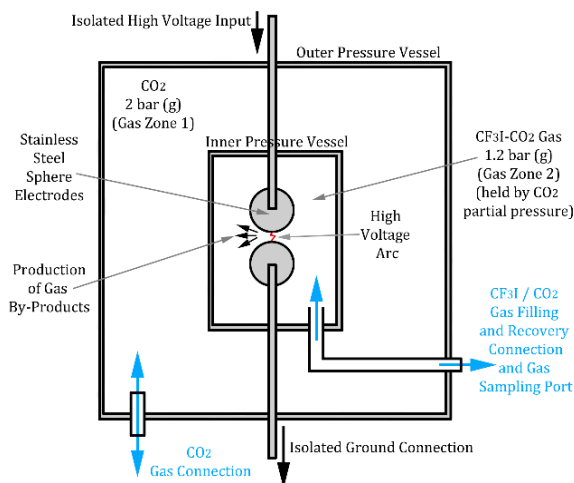

Figure 6. Gas Sample and Pressure Vessel Test Setup.

The high voltage bushing of the gas pressure vessel is connected to a 150 kV rms AC transformer (Ferranti, Hollinwood, England) and a capacitive divider (Ferranti, Hollinwood, England) with a ratio of 6736:1 which allows for voltage measurements to be taken as shown in Figure 7. The current was measured upon breakdown of the gas gap using a current transformer (CT) (Stangenes Industries Inc, Palo Alto, CA, USA) which was connected around the grounding strap connected to the ground electrode. Each breakdown across the tested gas gap produces a separate voltage and current waveform which is recorded using an oscilloscope (Teledyne LeCroy, Glasgow, UK) triggered by the rise in current on the grounded electrode, an example of this is shown in Figure 8. For each event recorded the voltage on the output of the transformer is slowly increased until a breakdown occurs at which point it is lowered until the arc is self-extinguished by the gas. A constant measurement of the

voltage applied to the test gas gap is also recorded using a secondary oscilloscope (Teledyne LeCroy), which helps determine a breakdown or no-breakdown scenario. When a breakdown occurs, the output voltage of the transformer drops because it has an earth fault allowing the flow of current to ground, under no-breakdown conditions the current is zero and the voltage is a steady oscillating 50 Hz AC waveform.

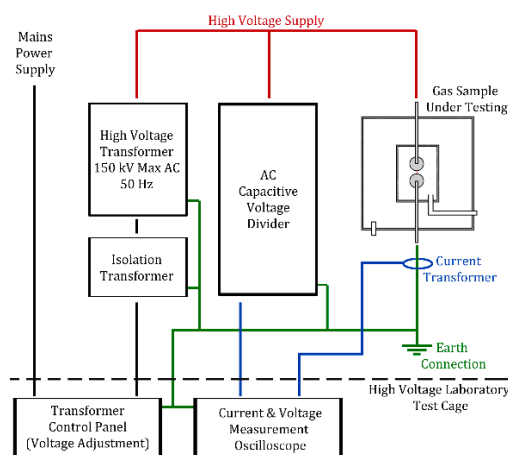

Figure 7. High Voltage Test Arrangement.

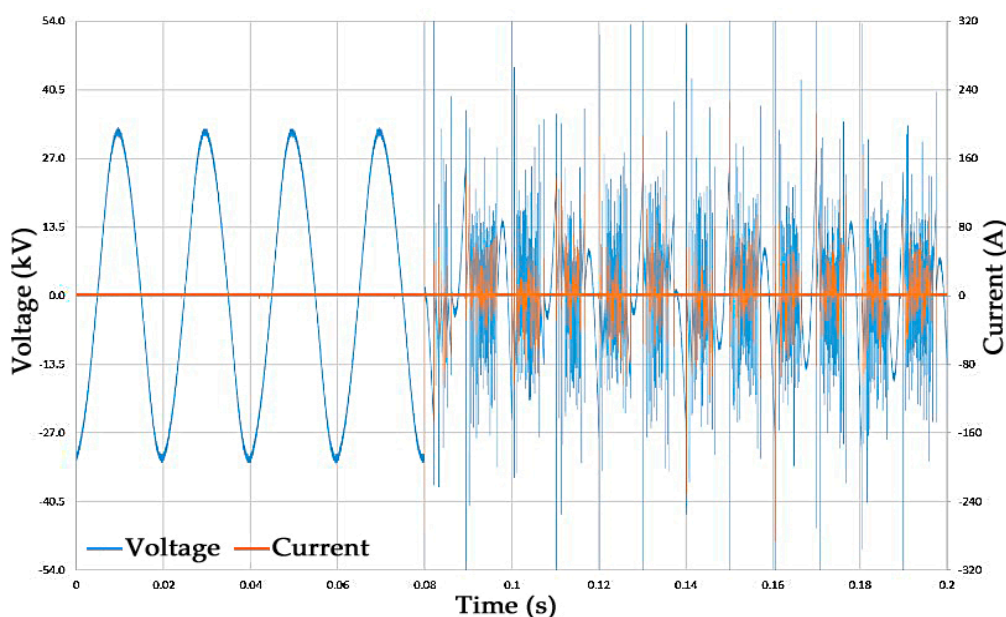

Figure 8. Voltage and current measurement of a breakdown event in CF_3I at 1.2 bar (g).

After filling the pressurised gas vessel under test to 1.2 bar (g) a sample of the gas or gas mixture is taken using a stainless steel sampling tube. This is then connected to the GCMS which allows for different molecules to separate through the gas chromatography column and its mass spectrum to be analysed using the MS. The gas in the pressurised vessel is not replaced and therefore every time a sample is taken the gas pressure and density between the sphere gas gap is lowered, therefore, reducing the overall high voltage insulation strength. An initial sample of each gas/gas mixture is analysed using the GCMS to confirm its identity and identify whether any contamination exists before any high voltage arcing takes place, an example of this is shown in Figures 1–3. After the initial sample is taken the gas sampling section is connected to the pressure vessel for the duration of the high voltage tests and only removed to allow the gas sample to be introduced to the GCMS. For each gas mixture the gas sampler and GCMS are flushed using a carrier gas of pure Helium which is 99.999%

pure [18], therefore ensuring no-cross contamination takes place. During each run the GC oven is kept at a constant temperature of 50 °C for 5 min, the temperature is then ramped at 15 °C/min for 8 min and then kept at a constant temperature of 170 °C for a final 5 min leading to a total run time of 18 min. The GC is running the sample through for analysis in split mode with a ratio of 10:1. The MS is scanning for a mass between 5–350 with a step size of 0.1 m/z for the entire run.

For each test the vessel was flushed and vacuumed (<1 mbar [19]) and re-filled with CO₂ five times before the final sample was introduced to remove cross contamination from the connecting hoses/vessel etc. For the pure CF₃I test the vessel was flushed using helium and vacuumed fifteen times before the final sample of CF₃I was introduced into the system. After each group of tests containing CF₃I the gas/gas mixture was first recovered to a separate cylinder using a gas recovery system, thereby ensuring that the amount of CF₃I released is minimal before the system was flushed. The experiments were conducted in the following order: pure CO₂, 30%:70% CF₃I-CO₂ and then pure CF₃I to ensure as few solid by-products were left inside the vessel which could affect the next set of results. The initial sample was taken following filling but preceding any high voltage breakdown. The sampling tube was then re-attached to the vessel and 50 breakdowns across the gas sample were conducted. The sample was then connected to the GCMS where the gas was analysed, this procedure was then repeated once 100 breakdown events had been undertaken when a final gas sample was taken before the gas/gas mixture was recovered into a separate cylinder.

5. Conclusions

This paper experimentally evidences the use of CF₃I and CF₃I-CO₂ gas mixtures in high voltage gas insulated equipment as an alternative insulation medium and examines the by-products produced when AC breakdown events occur through these gases.

The experimental gas samples analysed using a GCMS show that in pure CF₃I the by-products from arcing events are: CF₄, C₂F₆, C₂F₄, C₃F₈, C₃F₆ or C₄F₈, C₂F₅I, C₃F₇I and C₃F₇IO with potential by-products of CHF₃ and C₂HF₅. In a 30:70% CF₃I-CO₂ gas mixture the gas samples analysed showed by-products of: C₂F₆O₃, C₂F₆, C₃F₈ and CF₄ with potential by-products of C₂H₃F₃, C₂F₅I or C₂F₉I, C₂HF₅ and CHF₃.

It can be shown that prior to the breakdown tests being carried out, in both the pure CF₃I and CF₃I-CO₂ gas samples, that both CHF₃ and C₂HF₃ are detected so these are potential by-products, but it is difficult to conclusively prove this from these results. From both the pure CF₃I and CF₃I-CO₂ breakdown tests it can be shown that CF₄, C₂F₆, C₃F₈ and C₂F₅I are produced as gaseous by-products. In the pure CF₃I breakdown tests, the gas analysis showed additional by-products of C₂F₄, C₃F₆, C₃F₇I, C₃F₇IO and potentially C₄F₈ which were not identified in the CF₃I-CO₂ gas mixture breakdown tests. In the GCMS analysis of the CF₃I-CO₂ gas mixture after breakdown it is identified that additional by-products of C₂F₆O₃ and potentially C₂H₃F₃ and C₂F₉I are produced which are not detected in the analysis of pure CF₃I after breakdown, these by-products are produced as a direct result of the interaction between CF₃I and CO₂. All potential by-products of CF₃I and CF₃I-CO₂ and their associated hazards and exposure controls are detailed more extensively in Table A1.

It is necessary to point out that if CF₃I reacted with any of the materials used in the filling valve, hose, pressure vessel wall or gas connections/sampling port during its 10 hour filling time that these by-products may be included in these results. It is also important to note that iodine is produced in a semi-solid state from arcing events in CF₃I gas mixtures as shown in reference [20].

Future work will involve further analysis into the gaseous by-products of CF₃I gas mixture with other potential buffer gases.

Author Contributions: Conceptualization, P.W.; Methodology, P.W.; Validation, P.W.; Formal analysis, P.W.; Investigation, P.W.; Data curation, P.W.; Writing—original draft preparation, P.W.; Writing—review and editing, P.W. and A.M.H.; Visualization, P.W.; Project administration, P.W. and A.M.H.; Funding acquisition, A.M.H.

Funding: This research was funded by the EU/Welsh Government funded project FLEXIS (www.flexis.wales).

Conflicts of Interest: The authors declare no conflict of interest.

Appendix A

Table A1. Potential By-Products of CF₃I and CF₃I-CO₂ gas mixtures and their associated hazards and exposure controls. Note: data retrieved was correct at time of writing 19/03/2019, however, it is subject to frequent change and re-evaluation.

Gas Detected	CAS Number	Molecular Weight	Labels	Exposure Limits	Exposure Controls	Reference
CO ₂ —Carbon Dioxide	CAS-No. 124-38-9 EC No. 204-696-9	44.01 g/mol	H280: Contains gas under pressure; may explode if heated.	TWA 5000 ppm 9150 mg/m ³ STEL 15,000 ppm 27,400 mg/m ³ TWA 5000 ppm 9000 mg/m ³	P403: Store in a well-ventilated place.	[21]
CF ₃ I—Methane, trifluoroiodo-	CAS-No.: 2314-97-8 EC-No.: 219-014-5 Index-No.: 602-086-00-0	195.91 g/mol	H341 Suspected of causing genetic defects.	LCLo inhalation 1 pph/4H (10,000 mg/kg)	P280 Wear protective gloves/ protective clothing/ eye protection/ face protection. P410 Protect from sunlight. P502 Refer to manufacturer/ supplier for information on recovery/ recycling	[15] [22,23]
CO—Carbon Monoxide	CAS-No. 630-08-0 EC-No. 211-128-3 Index-No. 006-001-00-2	28.01 g/mol	H220 Extremely flammable gas. H331 Toxic if inhaled. H360D May damage the unborn child. H372 Causes damage to organs through prolonged or repeated exposure.	STEL 200 ppm TWA 30 ppm LC50 Inhalation-Rat-4 h-1807 ppm	Avoid contact with skin, eyes and clothing. Wash hands before breaks and immediately after handling the product.	[24]
CF ₄ —Tetrafluoromethane	CAS number: 75-73-0	88.01 g/mol	H280: Contains gas under pressure; may explode if heated. H315: Causes skin irritation. H319: Causes serious eye irritation. H335: May cause respiratory irritation.	No occupational exposure limit. DNEL not available PNEC not available.	P271: Use only outdoors or in a well-ventilated area. P280: Wear protective gloves/protective clothing/eye protection/face protection. R36/37/38: Irritating to eyes, respiratory system and skin. R44: Risk of explosion if heated under confinement. S36/37/39: Wear suitable protective clothing, gloves and eye/face protection. S45: In case of accident or if you feel unwell, seek medical advice immediately	[25,26]
C ₂ F ₆ —Ethane, hexafluoro-	CAS number: 76-16-4 EINECS number: 200-939-8	138.01 g/mol	H315: Causes skin irritation. H319: Causes serious eye irritation. H335: May cause respiratory irritation.	LC inhalation 20 pph/2H (200,000 mg/kg) LD50 4400 mg/kg	P261: Avoid breathing gas. P271: Use only outdoors or in a well-ventilated area. P280: Wear protective gloves/protective clothing/eye protection/face protection.	[27]
C ₂ F ₄ —Ethene, tetrafluoro-	CAS No.: 116-14-3 EC No. 204-126-9 UN No. 1081	100.02 g/mol	H220 (90.55%): Extremely flammable gas [Danger Flammable gases] H350 (85.07%): May cause cancer [Danger Carcinogenicity] H371 (73.63%): May cause damage to organs [Warning Specific target organ toxicity, single exposure]	LC50 inhalation 40,000 ppm/4H (40,000 mg/kg) LC50 inhalation 143 gm/m ³ /4H (143,000 mg/kg) LC50inhalation 116 gm/m ³ /4H (116,000 mg/kg)	P201 Obtain special instructions before use, P210 Keep away from heat, hot surface, sparks, open flames and other ignition sources. - No smoking, P260 Do not breathe dust/fume/gas/mist/vapors/spray, P281 Use personal protective equipment as required, P308 + P313, P309 + P311 if exposed or if you feel unwell Call a POISON CENTER or doctor, P377, P381, P403 Store in a well-ventilated place, P405, P410 + P403 Protect from sunlight.	[28]
CHF ₃ —Fluoroform	CAS number: 75-46-7 EINECS number: 200-872-4	70.01 g/mol	H315: Causes skin irritation. H319: Causes serious eye irritation. H335: May cause respiratory irritation.	LC50 > 200,000 ppm/2H LC50 > 663,000 ppm/4H	P271: Use only outdoors or in a well-ventilated area. P280: Wear protective gloves/protective clothing/eye protection/face protection. R36/37/38: Irritating to eyes, respiratory system and skin. S36/37/39: Wear suitable protective clothing, gloves and eye/face protection. S45: In case of accident or if you feel unwell, seek medical advice immediately (show the label where possible)	[29,30]
C ₂ F ₆ O ₃ —Trioxide, bis(trifluoromethyl)	CAS No. 1718-18-9	186.01 g/mol	No data available.	No data available.	No data available.	[31]

Table A1. Cont.

Gas Detected	CAS Number	Molecular Weight	Labels	Exposure Limits	Exposure Controls	Reference
C ₃ F ₈ —Perfluoropropane	CAS number: 76-19-7 EINECS number: 200-941-9	188.02 g/mol	H280: Contains gas under pressure; may explode if heated. H319: Causes serious eye irritation. H335: May cause respiratory irritation.	LD 20 mL/kg (20 mg/kg)	P260: Do not breathe gas. P271: Use only outdoors or in a well-ventilated area. P280: Wear protective gloves/protective clothing/eye protection/face protection.	[32]
C ₂ HF ₅ —Ethane, pentafluoro	CAS number: 354-33-6 EC No. 206-557-8	120.02 g/mol	H280: Contains gas under pressure; may explode if heated. H315: Causes skin irritation. H319: Causes serious eye irritation. H335: May cause respiratory irritation.	LC50 inhalation 2910 gm/m ³ /4H (2910,000 mg/kg) LC50inhalation 2735 gm/m ³ /2H (2,735,000 mg/kg)	P260: Do not breathe gas. P271: Use only outdoors or in a well-ventilated area. P280: Wear protective gloves/protective clothing/eye protection/face protection.	[33,34]
C ₃ F ₆ —Hexafluoropropene	CAS-No.: 116-15-4 EC-No.: 204-127-4 Index-No.: 602-061-00-4	150.02 g/mol	H332 Harmful if inhaled. H335 May cause respiratory irritation. H371 May cause damage to organs. H373 May cause damage to organs through prolonged or repeated exposure.	LC50 750 ppm/4H LC16 5200 mg/m ³ /2H LC50 1600 mg/m ³ /2H LC84 13,400 mg/m ³ /2H	P260 Do not breathe dust/fume/gas/mist/vapours/spray. P308 + P311 IF exposed or concerned: Call a POISON CENTER/doctor. P410 + P403 Protect from sunlight. Store in a well-ventilated place.	[35,36]
C ₄ F ₈ —Cyclobutane, octafluoro-	CAS number: 115-25-3 EINECS number: 204-075-2	200.03 g/mol	H315: Causes skin irritation. H319: Causes serious eye irritation. H335: May cause respiratory irritation. H280: Contains gas under pressure; may explode if heated.	LCLo inhalation 78 pph/2H (780,000 mg/kg)	P271: Use only outdoors or in a well-ventilated area. P261: Avoid breathing gas. P280: Wear protective gloves/protective clothing/eye protection/face protection.	[37]
C ₂ H ₃ F ₃ —Ethane, 1,1,1-trifluoro-	CAS number: 420-46-2	84.04 g/mol	H220: Extremely flammable gas. H315: Causes skin irritation. H319: Causes serious eye irritation. H335: May cause respiratory irritation.	LC50 inhalation 54 pph/4H (540,000 mg/kg)	P210: Keep away from heat, hot surfaces, sparks, open flames and other ignition sources. No smoking. P280: Wear protective gloves/protective clothing/eye protection/face protection.	[38,39]
C ₂ F ₅ I—Pentfluoroethyl iodide	CAS-No.: 354-64-3 EC-No.: 206-566-7	245.92 g/mol	H315 Causes skin irritation. H319 Causes serious eye irritation. H335 May cause respiratory irritation.	LC inhalation 40,000 ppm/4H (40,000 mg/kg)	P261 Avoid breathing dust/fume/gas/mist/vapours/spray. P305 + P351 + P338 IF IN EYES: Rinse cautiously with water for several minutes. Remove contact lenses, if present and easy to do. Continue rinsing. P410 + P403 Protect from sunlight. Store in a well-ventilated place. EUH044 Risk of explosion if heated under confinement. 2	[40,41]
C ₂ F ₉ I—Tetrafluoro(pentafluoroethyl)iodide	CAS-No.: 20636-76-4	321.91 g/mol	No data available	No data available	No data available	[42]
I ₂ —Iodine (CF ₃ I test only)	CAS-No.: 7553-56-2 EC-No.: 231-442-4 Index-No.: 053-001-00-3	253.81 g/mol	H312 + H332 Harmful in contact with skin or if inhaled. H315 Causes skin irritation. H319 Causes serious eye irritation. H335 May cause respiratory irritation. H372 Causes damage to organs (Thyroid) through prolonged or repeated exposure if swallowed. H400 Very toxic to aquatic life.	STEL 0.1 ppm LD50 Oral-Rat-14,000 mg/kg LC50 Inhalation-Rat-4 h- > 4.588 mg/L LC50 Dermal-Rat-male-1425 mg/kg	P261 Avoid breathing dust. P273 Avoid release to the environment. P280 Wear protective gloves/protective clothing. P305 + P351 + P338 IF IN EYES: Rinse cautiously with water for several minutes. Remove contact lenses, if present and easy to do. Continue rinsing. P314 Get medical advice/attention if you feel unwell.	[43]

Table A1. Cont.

Gas Detected	CAS Number	Molecular Weight	Labels	Exposure Limits	Exposure Controls	Reference
C ₃ F ₇ I—Perfluoropropyl iodide	CAS-No.: 754-34-7 EC-No.: 212-045-5	295.93 g/mol	H315 (100%): Causes skin irritation H319 (100%): Causes serious eye irritation H335 (75%): May cause respiratory irritation [Warning Specific target organ toxicity, single exposure; Respiratory tract irritation]	LC50 Inhalation-2 h-404,000 mg/m ³	P261 Avoid breathing dust/fume/gas/mist/vapors/spray, P271 Use only outdoors or in a well-ventilated area, P280 Wear protective protection, P302 + P352 If on skin wash with plenty of water, P304 + P340 If inhaled remove victim to fresh air, P305 + P351 If in eyes rinse cautiously with water for several minutes, P312 Call a poison centre or doctor if you feel unwell, P321, P362 Take off contaminated clothing, P403 + P233 Store in a well-ventilated place, P405 Store locked up.	[44,45]
C ₃ F ₇ IO—Tetrafluoro-1 trifluoromethoxy 1-iodoethane 1,2,2,2-Tetrafluoro-1-iodoethyl trifluoromethyl ether	CAS-No.: 139604-89-0	311.92 g/mol	H302 Harmful if swallowed [Warning Acute toxicity, oral] H312 Harmful in contact with skin. H315 Causes skin irritation H319 Causes serious eye irritation H332 Harmful if inhaled H335 May cause respiratory irritation [Warning Specific target organ toxicity, single exposure; Respiratory tract irritation]	No data available	P261 Avoid breathing dust/fume/gas/mist/vapors/spray, P264 Wash thoroughly after handling, P271 Use only outdoors or in a well-ventilated area, P280 Wear protective protection, P301 + P312 f swallowed call a poison centre if you feel unwell, P302 + P352 If on skin wash with plenty of water, P304 + P312 If inhaled call a poison centre or doctor if you feel unwell, P304 + P340 If inhaled remove victim to fresh air, P305 + P351 + P338 If in eyes rinse cautiously with water for several minutes, P312 Call a POISON CENTER or doctor if you feel unwell, P321, P322, P330 Rinse mouth, P332 + P313 If skin irritation occurs get medical advice/attention, P337 + P313 If eye irritation persists get medical advice/attention, P362 Take off contaminated clothing, P363 Wash contaminated clothing before reuse, P403 + P233 Store in a well-ventilated place & Keep container tightly closed, P405 Store locked up.	[46]

References

1. Widger, P.; Haddad, A.M. Evaluation of SF₆ Leakage from Gas Insulated Equipment on Electricity Networks in Great Britain. *Energies* **2018**, *11*, 2037. [[CrossRef](#)]
2. Myhre, G.; Shindell, D.; Bréon, F.M.; Collins, W.; Fuglestedt, J.; Jianping, H.; Koch, D.; Lamarque, J.F.; David, L.; Mendoza, B.; et al. *Anthropogenic and Natural Radiative Forcing*; Cambridge University Press: Cambridge, UK, 2013.
3. Intergovernmental Panel on Climate Change (IPCC). *Working Group I Contribution to Fourth Assessment Report of the Intergovernmental Panel on Climate Change*; Cambridge University Press: Cambridge, UK, 2007.
4. National Grid. National Grid Electricity Transmission Network Innovation Allowance Annual Summary. 2016/2017. Available online: <https://www.nationalgrid.com/sites/default/files/documents/National%20Grid%20Electricity%20Transmission%20NIA%20Annual%20Summary%202016-17.pdf> (accessed on 12 September 2018).
5. ABB. AirPlus TM: An Alternative to SF₆ as an Insulation and Switching Medium in Electrical Switchgear. Available online: https://library.e.abb.com/public/3405a31190934a8c98997eca8fc811be/ABB%20Review%202016_AirPlus_An%20Alternative%20to%20SF6.pdf (accessed on 12 September 2018).
6. Beroual, A.; Haddad, A. Recent Advances in the Quest for a New Insulation Gas with a Low Impact on the Environment to Replace Sulphur Hexafluoride (SF₆) Gas in High-Voltage Power Network Applications. *Energies* **2017**, *10*, 1216. [[CrossRef](#)]
7. Widger, P.; Haddad, A.; Griffiths, H. Breakdown performance of vacuum circuit breakers using alternative CF₃I-CO₂ insulation gas mixture. *IEEE Trans. Dielectr. Electr. Insul.* **2016**, *23*, 14–21. [[CrossRef](#)]
8. Chen, L.; Widger, P.; Kamarudin, M.S.; Griffiths, H.; Haddad, A. CF₃I Gas Mixtures: Breakdown Characteristics and Potential for Electrical Insulation. *IEEE Trans. Power Deliv.* **2017**, *32*, 1089–1097. [[CrossRef](#)]
9. Widger, P.; Griffiths, H.; Haddad, A. Insulation strength of CF₃I-CO₂ gas mixtures as an alternative to SF₆ in MV switch disconnectors. *IEEE Trans. Dielectr. Electr. Insul.* **2018**, *25*, 330–338. [[CrossRef](#)]
10. Li, Y.; Zhang, X.; Zhang, J.; Xiao, S.; Xie, B.; Chen, D.; Gao, Y.; Tang, J. Assessment on the toxicity and application risk of C₄F₇N: A new SF₆ alternative gas. *J. Hazard. Mater.* **2019**, *368*, 653–660. [[CrossRef](#)] [[PubMed](#)]
11. Rabie, M.; Franck, C.M. Assessment of Eco-friendly Gases for Electrical Insulation to Replace the Most Potent Industrial Greenhouse Gas SF₆. *Environ. Sci. Technol.* **2018**, *52*, 369–380. [[CrossRef](#)] [[PubMed](#)]
12. Zhang, X.; Li, Y.; Xiao, S.; Tang, J.; Tian, S.; Deng, Z. Decomposition Mechanism of C₅F₁₀O: An Environmentally Friendly Insulation Medium. *Environ. Sci. Technol.* **2017**, *51*, 10127–10136. [[CrossRef](#)] [[PubMed](#)]
13. Kamarol, M.; Nakayama, Y.; Hara, T.; Ohtsuka, S.; Hikita, M. Gas Decomposition Analysis of CF₃I under AC Partial Discharge of Non-uniform Electric Field Configuration. In Proceedings of the 10th Japan-Korea Joint Symposium on Electrical Discharge and High Voltage Engineering, Shibaura Institute of Technology, Tokyo, Japan, 15–17 November 2007; Paper 16P-15. pp. 161–164.
14. Aalco. Stainless Steel: 1.4301 Sheet and Plate. 24 May 2018. Available online: <http://www.aalco.co.uk/online-tools/product-finder/product.aspx?productid=2083> (accessed on 10 September 2018).
15. Tosoh Corporation, (Tosoh Corporation, Tokyo, Japan). CF₃I (Trifluoroiodomethane) Safety data sheet according to Regulation (EC) No. 1907/2006, Cas No. 2314-97-8. Personal communication, Available upon request. 2011.
16. BOC, Carbon dioxide Factsheet. 2017. Available online: <https://www.boconline.co.uk/en/legacy/attachment?files=tcm:t410-54560,tcm:410-54560,tcm:10-54560> (accessed on 9 September 2018).
17. Kasuya, H.; Katagiri, H.; Kawamura, Y.; Saruhashi, D.; Nakamura, Y.; Mizoguchi, H.; Yanabu, S. Measurement of Decomposed Gas Density of CF₃I-CO₂ Mixture. In Proceedings of the 16th International Symposium on High Voltage Engineering (ISH 2009), South African Inst. of Electrical Engineers, Cape Town, South Africa, 24–28 August 2009; Paper C-41. pp. 1–4.
18. BOC, Helium Purity level. 2018. Available online: <https://www.boconline.co.uk/shop/en/uk/helium--cp-grade--300bar-cylinder-171698#product1> (accessed on 12 September 2018).

19. Vacuum pump final vacuum level, Dilo B078R06 portable vacuum pump unit specifications, Dilo GmbH, Babenhausen, 2012 Product Catalogue. Available online: https://www.dilo-gmbh.com/fileadmin/user_upload/8._Downloads/2._englisch/2._SF6-Gashandling/2._SF6-Servicegeraete/Mini_Series_-_modular.pdf (accessed on 22 April 2019).
20. Widger, P.; Haddad, A. Solid by-products of a CF₃I-CO₂ insulating gas mixtures on electrodes after lightning impulse breakdown. *J. Phys. Commun.* **2017**, *1*, 025010. [CrossRef]
21. BOC, Carbon Dioxide Materials Safety Data Sheet. 2017. Available online: <https://www.boconline.co.uk/en/legacy/attachment?files=tcm:4410-39607,tcm:410-39607,tcm:10-39607> (accessed on 19 March 2019).
22. Sigma Aldrich, CF₃I Material Safety Data Sheet. Version 5.4 Revision Date: 18.04.2018. Available online: <https://www.sigmaaldrich.com/MSDS/MSDS/DisplayMSDSPage.do?country=GB&language=en&productNumber=171441&brand=ALDRICH&PageToGoToURL=https%3A%2F%2Fwww.sigmaaldrich.com%2Fcatalog%2Fproduct%2FALDRICH%2F171441%3Flang%3Den> (accessed on 19 March 2019).
23. U.S. National Library of Medicine National Center for Biotechnology Information, Pubchem, CF₃I. Available online: <https://pubchem.ncbi.nlm.nih.gov/compound/16843#section=Top> (accessed on 19 March 2019).
24. Sigma Aldrich, CO Material Safety Data Sheet. Version 5.4 Revision Date: 24.05.2016. Available online: <https://www.sigmaaldrich.com/MSDS/MSDS/DisplayMSDSPage.do?country=GB&language=en&productNumber=295116&brand=ALDRICH&PageToGoToURL=https%3A%2F%2Fwww.sigmaaldrich.com%2Fcatalog%2Fproduct%2Faldrich%2F295116%3Flang%3Den> (accessed on 19 March 2019).
25. Apollo Scientific, CF₄ Material Safety Data Sheet. Revision No. 2: 20/03/2013. Available online: http://www.apolloscientific.co.uk/downloads/msds/PC1650_msds.pdf (accessed on 19 March 2019).
26. BOC Online, CF₄ Material Safety Data Sheet. Version 1.2, Revision date: 04.11.2011. Available online: https://www.boconline.co.uk/en/images/sg_116_tetrafluoromethane_r14_tcm410-64642.pdf (accessed on 19 March 2019).
27. Apollo Scientific, C₂F₆ Material Safety Data Sheet. Version 3, Revision date: 28/01/2016. Available online: http://www.apolloscientific.co.uk/downloads/msds/PC7201_msds.pdf (accessed on 19 March 2019).
28. U.S. National Library of Medicine National Center for Biotechnology Information, Pubchem, C₂F₄. Available online: <https://pubchem.ncbi.nlm.nih.gov/compound/8301#section=Top> (accessed on 19 March 2019).
29. Apollo Scientific, CHF₃ Material Safety Data Sheet. Version 3, Revision date: 12/09/2011. Available online: http://www.apolloscientific.co.uk/downloads/msds/PC7400_msds.pdf (accessed on 19 March 2019).
30. U.S. National Library of Medicine National Center for Biotechnology Information, Pubchem, CHF₃. Available online: <https://pubchem.ncbi.nlm.nih.gov/compound/6373#section=Top> (accessed on 19 March 2019).
31. U.S. National Library of Medicine National Center for Biotechnology Information, Pubchem, C₂F₆O₃. Available online: <https://pubchem.ncbi.nlm.nih.gov/compound/549862#section=Top> (accessed on 19 March 2019).
32. Apollo Scientific, C₃F₈ Material Safety Data Sheet. Version 4, Revision date: 19/04/2018. Available online: http://www.apolloscientific.co.uk/downloads/msds/PC6210_msds.pdf (accessed on 19 March 2019).
33. Apollo Scientific, C₂HF₅ Material Safety Data Sheet. Version 3, Revision date: 19/04/2018. Available online: http://www.apolloscientific.co.uk/downloads/msds/PC5590_msds.pdf (accessed on 19 March 2019).
34. U.S. National Library of Medicine National Center for Biotechnology Information, Pubchem, C₂HF₅. Available online: <https://pubchem.ncbi.nlm.nih.gov/compound/9633#section=Top> (accessed on 19 March 2019).
35. Sigma Aldrich, C₃F₆ Material Safety Data Sheet. Version 5.2 Revision Date: 24.02.2016. Available online: <https://www.sigmaaldrich.com/MSDS/MSDS/DisplayMSDSPage.do?country=GB&language=en&productNumber=295388&brand=ALDRICH&PageToGoToURL=https%3A%2F%2Fwww.sigmaaldrich.com%2Fcatalog%2Fproduct%2Faldrich%2F295388%3Flang%3Den> (accessed on 19 March 2019).
36. U.S. National Library of Medicine National Center for Biotechnology Information, Pubchem, C₃F₆. Available online: <https://pubchem.ncbi.nlm.nih.gov/compound/8302#section=Top> (accessed on 19 March 2019).
37. U.S. National Library of Medicine National Center for Biotechnology Information, Pubchem, C₄F₈. Available online: <https://pubchem.ncbi.nlm.nih.gov/compound/8263#section=Top> (accessed on 19 March 2019).
38. Apollo Scientific, C₂H₃F₃ Material Safety Data Sheet. Version 3, Revision date: 22/06/2016. Available online: http://www.apolloscientific.co.uk/downloads/msds/PC7298_msds.pdf# (accessed on 19 March 2019).
39. U.S. National Library of Medicine National Center for Biotechnology Information, Pubchem, C₂H₃F₃. Available online: <https://pubchem.ncbi.nlm.nih.gov/compound/9868#section=Top> (accessed on 19 March 2019).

40. Sigma Aldrich, C₂F₅I Material Safety Data Sheet. Version 5.1 Revision Date: 25.02.2016. Available online: <https://www.sigmaaldrich.com/MSDS/MSDS/DisplayMSDSPage.do?country=GB&language=en&productNumber=331015&brand=ALDRICH&PageToGoToURL=https%3A%2F%2Fwww.sigmaaldrich.com%2Fcatalog%2Fproduct%2FALDRICH%2F331015%3Flang%3Den> (accessed on 19 March 2019).
41. U.S. National Library of Medicine National Center for Biotechnology Information, Pubchem, C₂F₅I. Available online: <https://pubchem.ncbi.nlm.nih.gov/compound/9636#section=Top> (accessed on 19 March 2019).
42. U.S. National Library of Medicine National Center for Biotechnology Information, Pubchem, C₂F₉I. Available online: <https://pubchem.ncbi.nlm.nih.gov/compound/550350#section=Top> (accessed on 19 March 2019).
43. Sigma Aldrich, I₂ Material Safety Data Sheet. Version 5.5 Revision Date 11.07.2018. Available online: <https://www.sigmaaldrich.com/MSDS/MSDS/DisplayMSDSPage.do?country=GB&language=en&productNumber=229695&brand=ALDRICH&PageToGoToURL=https%3A%2F%2Fwww.sigmaaldrich.com%2Fcatalog%2Fproduct%2Faldrich%2F229695%3Flang%3Den> (accessed on 19 March 2019).
44. Sigma Aldrich, C₃F₇I Material Safety Data Sheet. Version 5.0 Revision Date 22.02.2013. Available online: <https://www.sigmaaldrich.com/MSDS/MSDS/DisplayMSDSPage.do?country=GB&language=en&productNumber=P10402&brand=ALDRICH&PageToGoToURL=https%3A%2F%2Fwww.sigmaaldrich.com%2Fcatalog%2Fproduct%2Faldrich%2Fp10402%3Flang%3Den> (accessed on 19 March 2019).
45. U.S. National Library of Medicine National Center for Biotechnology Information, Pubchem, C₃F₇I. Available online: <https://pubchem.ncbi.nlm.nih.gov/compound/33977#section=Top> (accessed on 19 March 2019).
46. U.S. National Library of Medicine National Center for Biotechnology Information, Pubchem, C₃F₇IO. Available online: <https://pubchem.ncbi.nlm.nih.gov/compound/550245#section=Top> (accessed on 19 March 2019).

Sample Availability: Not Available.



© 2019 by the authors. Licensee MDPI, Basel, Switzerland. This article is an open access article distributed under the terms and conditions of the Creative Commons Attribution (CC BY) license (<http://creativecommons.org/licenses/by/4.0/>).