



School of Psychology

Ysgol Seicoleg

Examining the Relationship Between Shame and Disordered Eating

Thesis submitted in partial fulfilment of the requirement for

the degree of:

Doctorate of Clinical Psychology (DClinPsy)

South Wales Doctoral Programme in Clinical Psychology

Cardiff University

Elinor MacCormac

Supervised by: Dr John Fox and Dr Marc Williams

16th May 2019

List of Contents

List of Tables and Figures	5
Declarations	6
Acknowledgements.....	8
Summary of Thesis.....	9
Paper 1	10
Abstract.....	11
Key Words.....	11
Practitioner Points	11
Introduction	12
Method	14
Search Strategy.....	14
Inclusion and Exclusion Criteria.....	15
Quality Assessment	15
Data Synthesis	17
Results.....	18
Overview of Included Studies.....	19
Quality Assessment	20
Strength of the Evidence	21
Discussion	30
Review Aim 1.....	30
Review Aim 2.....	31
Sexual Orientation.....	34
Age.....	35
Strengths and Limitations of the Included Studies	36
Strengths and Limitations of the Review Process	37
Implications	39
Conclusions.....	40
References	41
Paper 2	49
Abstract.....	50

Key Words	50
Practitioner Points	51
Introduction	51
Classification of Eating Disorders	51
Shame and Eating Disorders	52
Shame and Pride Cycles in Eating Disorders	53
Perfectionism and Eating Disorders	54
Aims of the Current Study	55
Key Hypotheses	55
Subsidiary Hypotheses	56
Methodology.....	56
Participants.....	56
Recruitment.....	58
Measures.....	59
Eating Disorder Examination Questionnaire.....	59
Personal Feelings Questionnaire, version 2	60
The Other as Shamer Scale	60
Multi-Dimension Perfectionism Scale	60
Study Procedure	61
Analysis.....	62
Results.....	65
Correlations Between Independent and Dependent Variables	65
Multiple Regression Analysis.....	65
Discussion	67
Implications	67
Strengths and Limitations	67
Conclusions.....	71
References	72
Paper 3	78
Paper 1: Systematic Review.....	79
Rationale for Topic of Study.....	79

Inclusion and Exclusion Criteria.....	80
Literature Search	81
Quality Assessment	82
Decision to Undertake a Systematic Review	83
Data Extraction.....	84
Implications	84
Limitations of the Systematic Review	85
Reflections on the Systematic Review Process	86
Paper 2: Empirical Study.....	86
Rationale for Topic of Study.....	86
Methodology	87
Recruitment.....	88
Measures.....	90
Method of Analysis.....	91
Implications of Research	93
Personal and Professional Reflections	94
Dissemination Strategy	95
References	95
Appendices.....	101
Appendix A: Author Guidelines for Psychology and Psychotherapy Journal	101
Appendix B: Quality Assessment Results of Included Studies.....	107
Appendix C: Ethics Committee Study Approval.....	110
Appendix D: Participant Information Sheet	111
Appendix E: Consent Form	115
Appendix F: Debrief Form.....	116
Appendix G: Personal Feelings Questionnaire	118
Appendix H: Other as Shamer Scale	123
Appendix I: Eating Disorder Examination Questionnaire	124

Note. The Multidimensional Perfectionism Scale (Hewitt & Flett, 1990) has not been included in appendices as the measure is not open access.

Lists of Tables and Figures

List of Tables Paper 1

Table 1: AXIS Critical Domains	16
Table 2: Ratings of Overall Confidence in the Results of the Study	17
Table 3: Characteristics of Included Studies	22

List of Figures Paper 1

Figure 1: PRISMA Flow of Information Through the Systematic Review Process	18
--	----

List of Tables Paper 2

Table 1: Country of Origin of T1 and T2 Sample.....	57
Table 2: Cronbach's Alpha Scores for MPS Subscales and Pearson's Correlation Coefficient at T1 and T2	61
Table 2: Pearson's Correlation Scores for All Independent Variables with EDEQ	65
Table 3: Hierarchical Multiple Regression Coefficients for All Significant Predictors of T2 EDEQ	66

List of Figures Paper 2

Figure 1: Two-wave mediation Model 1	63
Figure 2: Two-wave mediation Model 2	63
Figure 3: Two-wave mediation Model 3	64
Figure 4: Two-wave mediation Model 4	64

List of Figures Paper 3

Figure 1: Baron and Kenny (1986) Mediation Model	92
Figure 2: Two-wave Longitudinal Mediation Model (Jose, 2013)	93

Acknowledgements

Firstly, I would like to thank my supervisors, Dr Marc Williams and Dr John Fox, whose knowledge, support and advice has been invaluable throughout this process. I would also like to express my gratitude to my friends on the course for their support; whether our plans involved impromptu holidays, being seriously underprepared whilst taking part in relay sporting events, or just meeting up for a meal, their sense of fun and enthusiasm has made the last three years some of the most enjoyable I've had. I'd particularly like to thank Natalie for her support throughout this project. This process felt a lot less daunting because I had someone to share tips and advice with (including training tips- I cannot remember why we thought our third year was the right time to run a marathon!).

A heartfelt thank you to my mum for her constant encouragement and reassurance, and for reminding me of my inspiration when I needed him most; my dad. I know he would be proud of me.

I would like to thank my partner, Andy, for always believing in me and reminding me to believe in myself. His ridiculous sense of humour and his ability to make a cup of coffee far superior in quality to my own has kept a smile on my face throughout this process. Finally, I would like to thank Reverend Miller and Captain Wilson for their cuddles and unwavering ability to distract me when I needed it most (and at times when I didn't).

Summary of Thesis

Shame has been indicated in the development and maintenance of a range of mental health difficulties, including eating disorders. Understanding the interaction between shame and other factors relating to eating disordered behaviour will enable researchers and clinicians to adapt and apply the most effective interventions to target these factors when treating eating disorders.

Paper 1 presents a systematic review examining whether there is a relationship between shame and BMI in men. 15 studies met the inclusion and exclusion criteria for inclusion in the review. Study quality was assessed with the AXIS tool before data extraction. There appears to be a trend in the research indicating a relationship between shame and BMI in men. However, due to recurrent methodological and reporting quality issues in the evidence base, no firm conclusions can be drawn. Clinical and research considerations are addressed.

Paper 2 presents a longitudinal examination of the relationship between shame and perfectionism in disordered eating. A community sample of 149 adults completed measures of internal and external shame, perfectionism and disordered eating at baseline and again six months later. Data was analysed to identify whether shame and perfectionism independently predict disordered eating, and if perfectionism plays a mediating role in the relationship between shame and disordered eating. Internal and external shame and perfectionism were significantly correlated with disordered eating. After controlling for baseline eating disorder, socially prescribed perfectionism predicted disordered eating with a small effect size. No other independent variables predicted disordered eating. Implications of these findings are discussed, and future research considerations are outlined.

Paper 3 presents a critical appraisal of the research process. This paper includes reflections on the different elements of the research in both papers. It will discuss the implications of the findings and suggestions for clinical practice and future research. Personal and professional competency development is also discussed.

Paper 1 has been prepared in line with author guidelines for submission to Psychology and Psychotherapy journal (Appendix A). Tables and figures have been included in the main manuscript for reader clarity. For journal submission, these will be put at the end of the manuscript, as per journal guidelines.

Paper 1: Is There a Relationship Between Shame and BMI in Men? A Systematic Review

Word count (excluding tables/figures): 5,601

Abstract

Background: Research has shown a positive correlation between BMI and shame, but studies have predominantly looked at women. The 'social attractiveness' theory suggests that men are likely to experience shame when their body does not match sociocultural ideals. The current review aims to synthesise the available research to understand the relationship between BMI and shame in men.

Methods: Four major databases were searched (Embase, PubMed, PsychInfo, Web of Science) for studies examining shame and BMI in male samples. Included papers were examined for methodological and reporting quality using the AXIS tool. **Results:** 15 papers were included in the review. Recurring methodological limitations were noted in the studies, including cross-sectional design and adjusting measures without validation. In papers with higher quality, body shame was positively correlated with BMI with an effect size ranging from $r=.13$ to $r=.30$. This relationship appears smaller than in women. **Conclusion:** There appears to be a trend in the research indicating a positive relationship between body shame and BMI in men. However, no firm conclusions can be drawn due to the significant methodological and reporting limitations within the evidence base. Clinical and research implications of this finding are discussed.

Key Words

BMI, shame, males, AXIS, body shame, body image

Practitioner Points

- There is evidence warranting further examination of the relationship between shame and BMI in men
- The evidence base in this area is largely lacking in methodological and reporting quality.

Introduction

The emotion of shame arises from the self-appraisal that one has failed to meet one's own or others' standards of worth (Mascolo & Fischer, 1995; Tangney, 1995). In other words, a person feels shame when they judge themselves, or fear others have judged them as inadequate in some way (Barrett, 1995). Shame has been conceptualised as comprising two factors: internal and external (Gilbert, 2002). Internal shame refers to the negative judgements or evaluations one makes of oneself, whereas external shame refers to the perceived negative judgements or evaluations that others make of oneself (Troop & Redshaw, 2012). Both internal and external shame have been linked to a higher vulnerability to mental health problems, including eating disorders (Troop, Allan, Serpell & Treasure, 2008).

Gilbert proposed a relationship between shame and 'social attractiveness' (Gilbert, 1997). Being judged as socially attractive is important to gain social status and acceptance, and its pursuit motivates people to present themselves in a manner that elicits positive attention from others. Gilbert posits that shame is a mechanism to identify traits or behaviours of the self that should remain hidden to avoid the self being viewed as having low social attractiveness, thus preventing the diminishment of social status and social rejection.

Body weight is an important marker of social attractiveness in modern society: masculine ideals indicate a lean and muscular physique (Gattario et al., 2015) and sociocultural ideals of thinness have been propagated for women (Thompson, Heinberg, Altabe & Tantleff-Dunn, 1999). In this context, Gilbert's (1997) theory indicates that having a body weight that deviates markedly from social ideals is likely to lead to shame. The perception that one's body does not match either internalised or social standards is referred to as 'body shame' (McKinley & Hyde, 1996; Gilbert, 2002). Body shame has been linked to mental health problems, particularly with regard to disordered eating (Blythin et al., 2018).

The relationship between BMI and shame has been extensively examined in women and BMI has been found to significantly correlate with both dissatisfaction with one's perceived body image and levels of shame (Claudat, Warren & Durette, 2012; Tiggemann & Lynch, 2001). However, there is a relative paucity of research examining this relationship in men. This may be due to the finding that women are more vulnerable to sociocultural demands to conform to an ideal body type and to the impact of sociocultural messages that physical attractiveness reflects social attractiveness (Buote, Wilson, Strahan, Gazzola & Papps, 2011).

In western society, a lean and muscular physique is considered the ideal body type (Gattario et al., 2015). Indeed, as men become more dissatisfied with their body weight, their sense appreciation for their own body reduces (Tylka, 2013). Although women have been found to experience higher rates of body dissatisfaction (Brennan, Lalone & Bain, 2010), high levels of body dissatisfaction and weight concerns are also common in men (Hatoum & Bell, 2004). The socially valued male body type has grown more muscular over time (Leit et al., 2001) and it has been hypothesised that men may have a stronger desire for a muscular body shape than a specific weight (Furnham, Badmin & Sneade, 2002). As the majority of individuals seen clinically for body image issues and eating disorders are women, the research on treatments has tended to recruit female samples, reducing our understanding of these issues in men.

Given the difference in social pressures and expectations, we might expect different findings when reviewing the relationship between shame and weight in men. However, to date, there have been no published reviews of the evidence base examining this relationship. Therefore, this paper aims to review the current quantitative literature examining the association between body weight (as measured by Body Mass Index; BMI) and shame in men. Specifically, this review will examine trends in the research regarding:

1. Whether there is a positive relationship between BMI and shame in men due to the socially desirable lean male body type and the result of perceived lack of social attractiveness driving feelings of shame (Gilbert, 1997).
2. Whether this relationship appears weaker than that found in women, due to the stronger sociocultural drive for female 'thinness' (Ferreira, Pinto-Gouveia & Duarte, 2013) and the existence of a broader range of idealised body types among men (e.g., leaner or more muscular physiques).

Method

Search strategy.

Four electronic databases (Embase, PubMed, PsycINFO and Web of Science) were searched from inception to December 2018. The following terms were used for the search strategy: (a) "*shame*"; (b) "*male**", "*men*", "*boy**"; (c) "*BMI*", "*Body Mass Index*". The terms "*Shame*", "*Human Males*" and "*Body Mass Index*" were also searched as terms mapped to subject heading in groups a, b and c, respectively, in PsycINFO and Embase databases (this option is unavailable in PubMed and Web of Science databases). The search terms within each group were combined using the Boolean operator "OR", and each group was combined using the Boolean operator "AND". The term "*sham**" was not included in the search to avoid a high number of false positive results; instead, it was assumed that authors would include the word 'shame' when discussing the concept. Search results were screened by title and abstract. Remaining papers were read in full and checked for eligibility according to inclusion criteria. Reference lists from eligible papers were also examined to find additional relevant articles. This search process was repeated 3 months after the initial search to minimise the likelihood of papers being missed. The review protocol was not pre-registered.

Inclusion and exclusion criteria.

The following were included in the review: (a) peer-reviewed original research papers; (b) full-text articles available in English; (c) those reporting a quantitative methodology; (d) those studying a male sample or a mixed sample that reported separate analyses for the male subsample; (e) those that reported BMI; (f) those that measured shame independently (as opposed to being part of a grouping of several constructs); (g) those that statistically examined the relationship between BMI and shame.

Papers were excluded if they (a) experimentally manipulated either shame or BMI and/or (b) focused on evaluating treatments. This was to maintain the review focus on any naturally occurring relationship between shame and BMI.

Quality assessment.

All eligible papers were examined for risk of methodological and reporting bias using the AXIS quality assessment tool for cross-sectional studies (Downes, Brennan, Williams & Dean, 2016). The tool examines risk of bias in 20 areas of study design and reporting quality and each item was rated with the terms 'yes', 'no', or 'don't know'. See Table 1 for items identified as critical to the confidence in the validity and reliability of the study. These critical domains were checked and agreed by the research supervisor. If found lacking, critical domains were described as 'critical flaws' and all other items were deemed 'non-critical weaknesses' (a method of reporting quality based on that used by AMSTAR 2; Shea et al., 2017). The method of rating overall confidence in the studies' methodological and reporting quality is detailed in Table 2.

The author and an independent reviewer assessed the quality of a random selection of 50% of the sample of articles independently using the AXIS tool. The independent reviewer also examined the other 50% of the sample of articles after they had been quality assessed by the author, to check the author's consistency in applying the AXIS. Any discrepancies were resolved via discussion and in cases

of failed resolution, discrepancies were resolved by an independent third party who was familiar with the tool. No studies were excluded on the basis of the quality assessment.

Table 1

AXIS Critical Domains

Item Number	Description
5	Sample frame taken from appropriate population base to closely represent target population
6	Selection process likely to select participants representative of target population
8	Risk factor and outcome variables measured appropriate to the aims of the study
9	Risk factor and outcome variables measured correctly
10	Clear what was used to determine statistical significance
17	Authors' discussions and conclusions justified by the results
18	Limitations of the study discussed

Table 2

Ratings of Overall Confidence in the Results of the Study

Overall Confidence	Scoring	Description
High	No critical flaws with up to 4 non-critical weaknesses	The study provides a valid and reliable examination of the variables to address the question of interest
Moderate	Zero or one critical flaw with up to 4 non-critical weaknesses	The study may provide a valid and reliable examination of the variables
Low	One critical flaw with 5 or more non-critical weaknesses or 2 critical flaws with up to 4 non-critical weaknesses	The study has at least one critical flaw and may not provide a valid and reliable examination of the variables to address the question of interest
Critically low	Two critical flaws with 5 or more non-critical weaknesses or more than 2 critical flaws	The study has more than two critical flaws and cannot be relied on to provide a valid and reliable examination of the variables

Data synthesis.

Data regarding study characteristics (author, year of publication, title, design, sample characteristics, shame measure used and outcome) were extracted from each eligible study and recorded in Table 3. The current review summarises the results of the included studies narratively due to the difficulty synthesising results from studies that examine different populations and use different shame measures.

Results

The Preferred Reporting Items for Systematic Reviews (PRISMA; Moher, Liberati, Tatzlaff, & Altman, 2009) flow chart illustrates the screening process of the current review in Figure 1. Seventeen studies were excluded after being read in full. The papers that were excluded and reasons for exclusion are listed in Figure 1. Fifteen studies were included in the current review.

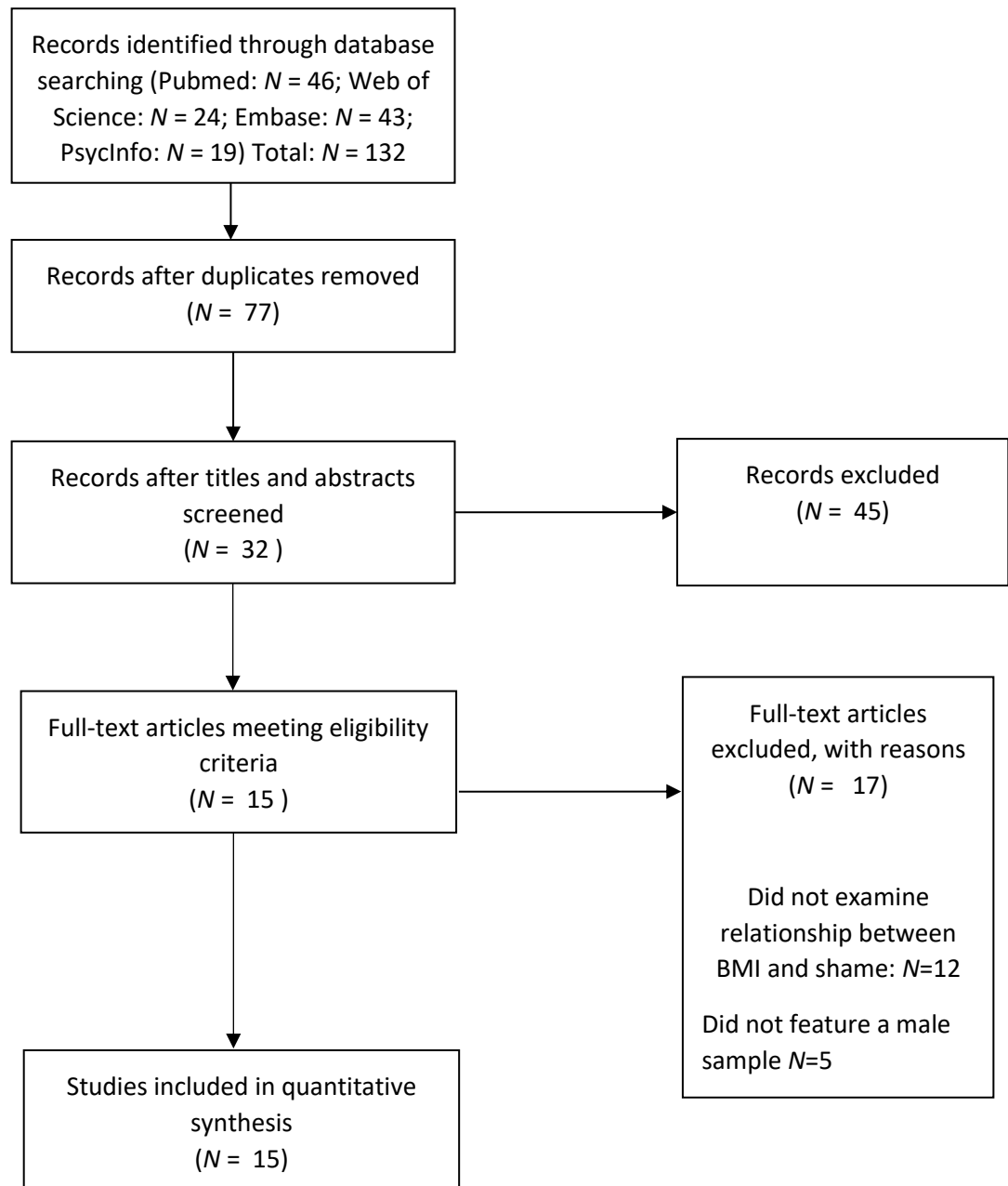

Figure 1: PRISMA flow of information through the systematic review process

Overview of included studies.

Table 3 shows the characteristics of the 15 studies included in the current review. 14 of the studies were cross-sectional and one was experimental. The experimental study was included because the data extracted from this study were unrelated to the experimentally manipulated measures. Fourteen used a non-clinical sample, and one study used a Binge Eating Disorder (BED) clinical sample. The Objectified Body Consciousness Scale (OBC; McKinley & Hyde, 1996) was the most commonly used measure of shame, with ten studies utilising either the whole measure (four studies) or the Body Shame subscale alone (six studies). The OBC scale has been found to have good validity and reliability (McKinley, 1998; McKinley & Hyde, 1996). Although originally developed for use with women, it has been found to have acceptable internal consistency and reliability and the Body Shame and Body Surveillance subscales are factorially sound when used with male samples (McKinley, 1998; McKinley & Hyde, 1996).

The characteristics of the participants in each of the included studies are shown in Table 3. Eight studies examined a male-only sample, with the other seven studies examining male and female samples separately. Three studies examined the impact of sexual orientation within their sample. In terms of age of the sample, one study used an adolescent sample, five studies examined a college population, and nine examined an adult population.

The results of the included studies are also shown in Table 3. Seven of the 15 studies found small or medium correlations between BMI and shame in men. One of these studies found a correlation between shame and BMI of medium strength in their homosexual sample only, with no significant correlation in their corresponding heterosexual sample.

Quality assessment.

Table 3 details the ratings of overall confidence in the methodological and reporting quality of each included study. There were several recurring issues with many of the included studies that became apparent when assessing their methodological and reporting quality. None of the included studies justified their sample size, which makes it difficult to assess the risk of the study having either under or overpowered analyses, thus limiting what can be reliably concluded from comparisons. Thirteen of the 15 studies took their sample from an inappropriate population base, meaning the study results are unlikely to be representative of the target population. Furthermore, the selection process was found to be inadequate in selecting participants representative of the target population in nine of the 15 studies (one of the studies was unable to be scored on this item as they had not defined their target population; Himmelstein & Tomiyama, 2015). Collectively, the recurrent quality issues with the samples used in the studies make it difficult to identify what populations the research are representative of and can be generalised to, thus limiting the comparative accuracy in this review.

Another issue found in ten of the 15 included studies was that variables were not measured appropriately; in these papers, questionnaires were either adjusted or translated without validating or piloting the changes. This makes it difficult to determine whether the measures are appropriately valid or reliable for use.

Most studies stated clear aims and target populations and measured appropriate outcomes to meet their aims. All included studies were clear in their reporting of how they determined statistical significance. The studies largely reported results for all analyses described in the methods and drew appropriate conclusions from them, whilst also reporting limitations of their study.

common weaknesses, such as failing to use a validated tool to measure psychological constructs (such as shame), raise significant doubt over the ability to make inferences based on these constructs. As a result, the present review will place more weight on the findings of the studies with higher quality, and exercise caution in interpreting the findings of any other studies.

Table 3

Characteristics of Included Studies

Authors (Year of Publication)	Title	Design	Sample Characteristics	Sample Sexual Orientation	Sample BMI	Sample Age	Shame Measure	Outcome	Quality
Castonguay, A.L., Pila, E., Wrosch, C., Sabiston, C.M. (2015)	Body-related self-conscious emotions relate to physical activity motivation and behaviour in men	Cross sectional	Community sample of adult males	[not reported]	Range= 16.28-33.27, M= 23.98, SD= 3.81	Range= 17-66, M= 23.72, SD= 10.92	WEB-SG	Body Shame was significantly correlated with BMI ($r=.26^*$)	High
Tylka, T.L., Kroon, A.M. (2013); Study 2	The Intuitive Eating Scale-2: Item refinement and psychometric evaluation with college women and men	Cross sectional	College students	[not reported]	Range= 16.50-59.06, M= 25.38, SD= 5.48	OVERALL: range= 18-53, M= 20.45, SD= 5.06	OBC (Body Shame & Body Surveillance subscales)	Body Shame was significantly correlated with BMI in men ($r=.26^{***}$) and in women ($r=.31^{***}$)	Moderate

Authors (Year of Publication)	Title	Design	Sample Characteristics	Sample Sexual Orientation	Sample BMI	Sample Age	Shame Measure	Outcome	Quality
Wiseman, M.C., Moradi, B. (2010)	Body image and eating disorder symptoms in sexual minority men: A test and extension of objectification theory	Cross sectional	Men who are sexually oriented toward men	Exclusively gay 66%, mostly gay 20%, bisexual 12%, mostly heterosexual 2%	Mean=27.03, SD=7.47	Range= 17-70, M=32.67, SD=13.83	OBC (Body Shame subscale)	Body Shame was significantly correlated with BMI ($r=.13^*$)	Low
Knauss, C., Paxton, S.J., Alasker, F.D (2008)	Body dissatisfaction in adolescent boys and girls: Objectified body consciousness, internalization of the media body ideal and perceived pressure from media	Cross sectional	Boys between 14-16 years	[not reported]	M= 20.64, SD=2.90	Range= 14-16, M=14.96, SD=0.75	OBC (Body Shame & Body Surveillance; Modifications: 2 additional items added to Body Shame, 3 items added to Body Surveillance; 7 point likert changed to 4 point; translated to German)	Body Shame was significantly correlated with BMI in boys ($r=.15^{***}$) and in girls ($r=.30^{***}$)	Low

Authors (Year of Publication)	Title	Design	Sample Characteristics	Sample Sexual Orientation	Sample BMI	Sample Age	Shame Measure	Outcome	Quality
Oliviera, S., Trindade, I., Ferreira, C. (2018)	Explaining male body attitudes: The role of early peer emotional experiences and shame	Cross sectional	Men from the Portuguese general population	[not reported]	Range= 16.98-43.60, M= 24.75, SD= 3.95	Range= 18- 60, M= 27.24, SD= 9.18	BISS OAS-2	Shame (measure encompassing external and internal shame; BISS) was significantly correlated with BMI ($r=.30^{***}$). No significant correlation found between External Shame (OAS- 2) and BMI ($r=-.07$).	Low
Boisvert, J.A., Harrell, W.A. (2009)	Homosexuality as a risk factor for eating disorder symptomatology in men	Cross sectional	Undergraduate men	93% (N=213) heterosexual, 5.7% (N=13) homosexual or bisexual	Heterosexual: M=23.83, SD=2.57, Homosexual: M=21.83, SD=2.86	Range= 18- 53, M= 21.86, SD= 3.39	OBC (Body Shame subscale)	No significant correlation found between Body Shame and BMI ($r=-.01$)	Critically low

Authors (Year of Publication)	Title	Design	Sample Characteristics	Sample Sexual Orientation	Sample BMI	Sample Age	Shame Measure	Outcome	Quality
Jambekar, S.A., Mashed, R.M., Grilo, C.M (2003)	Gender differences in shame in patients with binge-eating disorder	Cross sectional	Clinical sample of adults meeting DSM IV criteria for BED	[not reported]	M=40.73, SD=8.3 [only one decimal place reported for SD]	Range= 25- 66, M= 45.32, SD=8.80	ISS	No significant correlation found between Internalised Shame and BMI in men ($r=-.00$) or women ($r=.01$)	Critically low
Marta- Simoes, J., Ferreira, C., Mendes, A.L. (2016)	Exploring the effect of external shame on body appreciation among Portuguese young adults: The role of self- compassion	Cross sectional	Portuguese young adults	[not reported]	M= 23.54; SD = 3.14	Range= 18- 35, M=22.36, SD= 3.14	OAS	No significant correlation found between External Shame and BMI in men ($r=.16$) or women ($r=.10$)	Critically low

Authors (Year of Publication)	Title	Design	Sample Characteristics	Sample Sexual Orientation	Sample BMI	Sample Age	Shame Measure	Outcome	Quality
Boisvert, J.A., Harrell, W.A. (2012)	Ethnicity and spirituality as risk factors for eating disorder symptomatology in men	Cross sectional	Community sample of men	[not collected]	Aboriginal: M=28.52, SD=5.81, White: M=26.91, SD=4.34, Asian: M=24.58, SD=3.11	Range= 18- 80, M= 42.33, SD= 15.44	OBC (Body Shame subscale; 25% of items used: “I feel like I must be a bad person when I don’t look as good as I could” and “When I am not exercising enough, I question whether I am a good enough person.”)	No significant correlation found between Body Shame and BMI ($r=.00$)	Critically low
Daniel, S., Bridges, S.K. (2010)	The drive for muscularity in men: Media influences and objectification theory	Cross sectional	Male college students	85.7% heterosexual	[not reported]	M= 21.35, SD= 3.81	OBC (Body Shame subscale)	Body Shame was significantly correlated with BMI ($r=.17^{**}$)	Critically low

Authors (Year of Publication)	Title	Design	Sample Characteristics	Sample Sexual Orientation	Sample BMI	Sample Age	Shame Measure	Outcome	Quality
Rollero, C., Gattino, S., De Piccoli, N., Fedi, A. (2018)	Protective versus risk factors for self- objectification in different age and gender cohorts	Cross sectional	Heterosexual adults	[not reported]	M= 25.88, SD = 4.04†	OVERALL SAMPLE: Range= 21- 60, M=40.47, SD= 11.7	OBC (Body Shame subscale)	BMI (1=normal weight) significantly predicted Body Shame ($\beta=-0.13$, $t=-$ 2.38*)	Critically low
Martins, Y., Tiggemann, M., Kirkbride, A. (2007); Study 1	Those Speedos become them: The role of self- objectification in gay and heterosexual men's body image	Cross sectional	Homosexual and heterosexual men	98 homosexual; 103 heterosexual	Homosexual: M =24.54, SD =4.92. Heterosexual: M =25.38, SD =3.58	Range= 16- 40	OBC (Body Shame subscale)	No significant correlation found between Body Shame and BMI in the heterosexual sample ($r=.17$). Significant correlation was found in the gay sample ($r=.32^{**}$)	Critically low

Authors (Year of Publication)	Title	Design	Sample Characteristics	Sample Sexual Orientation	Sample BMI	Sample Age	Shame Measure	Outcome	Quality
Himmelstein, M., Tomiyaama, A.J. (2015)	It's not you, it's me: self- perceptions, antifat attitudes, and stereotyping of obese individuals	Within participants experimental design	University students	98.3% heterosexual	Range= 14.64-43.04, M= 22.33, SD= 3.45	[unclear; approximate M= 20.3]	OBC (Body Shame subscale)	No significant correlation found between Body Shame and BMI ($r=-$.06)	Critically low
Dumitrescu, A.L., Manolescu, B.N. (2011)	Body weight, shame, guilt and oral health: A path analysis model in undergraduate students	Cross sectional	First year medical students	[not reported]	Underweight (BMI: <18.5) N=1, normal weight (BMI 18.5-24.9) N=39, overweight (BMI: 25-30) N=5	M= 19.62, SD=2.62	WEB-SG	Male sample showed no significant correlation between Body Shame and BMI ($r=.22$). Female sample showed a significant correlation ($r=.43^{**}$)	Critically low

Authors (Year of Publication)	Title	Design	Sample Characteristics	Sample Sexual Orientation	Sample BMI	Sample Age
Mason, T. B., Lewis, R.J (2015)	Assessing the roles of impulsivity, food related cognitions, BMI and demographics in the dual pathway model of binge eating among men and women	Cross sectional	Undergraduate men and women	[not reported]	OVERALL SAMPLE: M=25.22, SD= 5.81	OVERALL SAMPLE (including women): M= 22.67, SD = 7.06

Note. All figures reported are for male samples only, unless otherwise stated. * $p < .05$ ** $p < .01$ *** $p < .001$, OBC: (McKinley & Hyde, 1996); WEB-SG: The Weight and Body-Related Shame and Guilt Scale (Condradt et al., 2007); ISS: OAS: Other as Shamer Scale (Goss, Gilbert & Allan, 1994); OAS-2: Other as Shamer Scale-2 (Matos, Pinto-Gouveia, G Body Image Shame Scale (Duarte, Pinto-Gouveia, Ferreira & Batista, 2015); DSM IV: The Diagnostic and Statistical M American Psychiatric Association, 2000); † These figures represent the whole sample, although only those with ‘norm in the analysis.

Discussion

The current study used systematic reviewing methodology to address two review aims relating to the relationship between shame and BMI in males. First, the conclusions that can be drawn regarding the two review aims will be considered, before discussing subsidiary findings of note with respect to sexual orientation and age. Then there will be a discussion of the quality and limitations of the included studies and recommendations for future directions for research.

Review aim 1: To examine whether trends in the research indicate a positive relationship between BMI and shame in men.

The review found mixed results; approximately half of the studies found a low or moderate correlation between shame and BMI. Many of the included studies were below the expected level of methodological and reporting quality, yet five of the six studies with the highest ranked quality of the included studies reported a significant positive correlation between body shame and BMI in men. Therefore, trends within the findings appear to support a link between BMI and shame in men. However, due to the low methodological and reporting quality of a large proportion of the evidence base, it is difficult to draw any confident conclusions regarding this relationship.

Gilbert's (1997) theory of social attractiveness provides one possible explanation for this trend in the findings; men with higher BMIs may perceive themselves as not matching the socially attractive body type (lean with low body fat; Tiggemann, Martins & Kirkbride, 2007), leading to body shame. The lack of consistency in findings across the included papers may be caused by the lower quality studies using a biased sample or failing to accurately measure shame. Another explanation may be that many men strive for a different body ideal; a more muscular body type (McFarland & Petrie, 2012). In men who strive for muscularity, a higher BMI may indicate a higher volume of lean muscle mass as opposed to body fat, meaning they are less likely to experience shame due to this higher BMI.

Research suggests that age influences the drive for a more muscular physique in men (Calzo, Corliss, Blood, Field & Austin, 2013), and as homosexual men often conform less strictly to the traditional male gender roles (Rieger, Linsenmeier, Gygax & Bailey, 2008), one might also expect sexual orientation to also influence drive for muscularity. However, the current review does not indicate a clear difference in age or sexual orientation in the samples used in the studies that found a significant relationship versus those that did not. It would be helpful for future research to examine whether other subgroups within the male population value a lower BMI or a more muscular physique more. Understanding what body ideal different groups of men have is important to better predict when they are likely to experience shame (for example, if they perceive their BMI is too high/low or if they perceive that they lack muscularity).

Review aim 2: To examine whether trends within the findings of the research suggest that this relationship is weaker in men than in women.

Seven studies examined BMI and shame with separate samples of males and females. Two studies found no significant relationship between body shame and BMI in their male sample but a significant relationship in their female sample (Dumitrescu et al., 2011; Mason & Lewis, 2015). It should be noted that both studies were deemed to have critically low quality due to numerous significant methodological and reporting flaws. As a result, conclusions cannot be accurately drawn or generalised from these papers. A further two studies found a significant correlation in both samples, with a stronger correlation in the female sample than the males (Knauss, Paxton & Alasker, 2008; Tylka & Kroon, 2013). Although Knauss, Paxton and Alasker (2008)'s study had low methodological and reporting quality, Tylka and Kroon (2013)'s study had moderate quality, which indicates greater confidence that their findings are valid and reliable. Therefore, we can conclude that there is a trend

in the current evidence base toward a finding that there is a positive relationship between BMI and shame in men, and that this appears weaker than that found in women.

The trend in gender differences found could be explained by the differing sociocultural body ideals for men and women; thinness is valued in women, whereas men are more likely to idealise a lean but muscular physique (Ambwani & Chmielewski, 2013; Tiggemann, Martins & Kirkbride, 2007). Therefore, the discrepancy between one's own body image and the idealised body image may not be adequately represented by BMI in men. This may explain why the correlation appears weaker in men than women.

One study only appeared to include those with a normal BMI in the analysis (although the reason for this is unclear; Rollero et al., 2018) and found that a normal BMI significantly predicted lower body shame in men. The study concluded that having a BMI in the normal range (presumably 18.5-24.9, although this is not stated in the study) was a protective factor against body shame. However, no relationship was found between BMI and body shame in women. While the study's authors did not draw conclusions regarding the cause of these findings, it is possible that women are more prone to a dichotomous view of BMI, in which BMI is appraised as either falling within the 'ideal' or 'non-ideal' category. Therefore, despite their BMI falling within the normal BMI range, it might not be within the 'ideal' body type for women and they may continue to perceive themselves as overweight (Crawford & Campbell, 1999). However, given that this study was found to have critically low methodological and reporting quality and no other BMI categories appear to have been analysed for comparison, it would be prudent to avoid generalising or placing much weight on the findings. Instead, conducting higher-quality studies on samples with different BMI ranges is necessary to understand whether the relationship with shame in men differs depending on BMI category.

Unlike the other studies that examined body shame, two studies examined different shame subtypes; internal shame (Jambekar, Masheb & Grilo, 2003) and external shame (Marta-Simoes, Ferreira & Mendes, 2016). Jambekar et al. (2003) examined an inpatient BED sample and concluded that the

lack of relationship between BMI and internal shame in both males and females may be due to Western society's obesity stigma plateauing when an individual reaches a certain weight. Therefore, Jambekar et al. have suggested that because the male and female samples' mean BMI was in the obese range, their experience of stigma, and thus shame, had already plateaued. This explanation suggests that stigma has a linear relationship with body weight until the individual reaches a certain level of overweight, at which point the level of stigma becomes static. If this is the case, such a plateau could arise due to changes in BMI not being perfectly correlated with changes in physical appearance; when individuals reach an obese weight range, others may be less able to recognise further weight gain and thus their stigma would not change and the individual would then be unlikely to experience further shame due to stigma. As this was the only study that examined this relationship in a clinical sample that had an average BMI in the obese range, more research is required to replicate these findings before conclusions can be drawn with confidence.

Marta-Simoes, Ferreira and Mendes (2016) examined a sample of young Portuguese adults and found no significant relationship between BMI and external shame in either men or women. This finding conflicts with the theory that the desire for social attractiveness drives individuals to present themselves in a socially attractive way (Gilbert, 1997); thin for women (Ferreira, Pinto-Gouveia & Duarte, 2013), and lean and muscular for men (Gattario et al., 2015). If they perceive their body to be discordant with the socially attractive ideal, they feel at risk of being rejected by others, thus experiencing external shame. As noted above, BMI may not be the most accurate measure of the male body ideal. However, based on the theoretical background, one would predict that BMI would be related to external shame in women in this study. Indeed, this has been found in a subsequent study (Duarte et al., 2017). The study by Marta-Simoes et al. (2016) was critically low in methodological and reporting quality and as subsequent research has found conflicting results in women, further research with higher quality is required to replicate these findings in men before drawing firm conclusions from them.

In addition to the primary aims of this review, the author noted two male subgroups that received focus; homosexual men and younger men. These will be considered in more detail.

Sexual orientation.

One study examining the impact of sexual orientation on the relationship between BMI and shame found a positive correlation of moderate strength in the homosexual sample, but no such relationship in the heterosexual sample (Martins, Tiggemann & Kirkbride, 2007). Although the two samples did not differ on BMI, the homosexual sample reported higher levels of both body shame and self-objectification. The authors concluded that these results were indicative that homosexual men's subculture is more objectifying, thus causing greater shame in this population. This study was considered to have critically low methodological and reporting quality mainly due to the use of new or adapted measures without validation. However, the study examined shame and self-objectification appropriately with validated tools. Additional reasons for the lower quality classification included suboptimal reporting quality and risk of bias in the sample. Consequently, although conclusions drawn from this study may be limited in their generalisability, the study does show evidence of an effect of sexual orientation on the relationship between BMI and shame in men.

In addition, one study examined the relationship between BMI and shame in a sample of 'sexual minority' men (men who indicated some sexual attraction to men; Wiseman & Moradi, 2010) and found a significant, albeit weak, positive correlation. This study did not use a comparison group of heterosexual men, which limits the ability to draw conclusions about how much the relationship between BMI and shame was impacted by the sample's sexual orientation. This study was low in methodological and reporting quality, indicating caution when interpreting generalising these findings to other populations. Although Boisvert and Harrel (2009) examined male sexual orientation in their study, they did not examine heterosexual and homosexual samples separately when examining the relationship between BMI and shame. Furthermore, their overall sample had a very small number of

homosexual participants and as such, it is likely to more closely represent the heterosexual male population, so no conclusions in this area can be drawn from the study.

When taken together, the findings from these studies suggest that there is a relationship between BMI and shame in homosexual men and there is some evidence to suggest that the relationship is stronger than in heterosexual men. This may be indicative of increased objectification in the homosexual subculture causing more shame, as proposed by Martins, Tiggemann and Kirkbride (2007) or the result of homosexual men's greater susceptibility to media images promoting a thin body type (Strong, Williamson, Netmeyer, & Greer, 2001) and experiencing shame when this does not match their actual body shape. However, due to the significant limitations in the methodological and reporting quality of the studies and the limited amount of research in this area, no firm conclusions can be drawn before further high-quality research is conducted to examine this relationship.

Age.

One study examined the relationship between BMI and body shame in adolescents (Knauss & Paxton, 2008) and found a positive, albeit weak, correlation between shame and BMI in the male sample, and a medium correlation in the female sample. This study was found to have low quality as the sample were recruited from Switzerland only and the study adapted validated measures without validating the changes. However, culturally there is no obvious reason to suspect that adolescent boys in this country would be experiencing a significantly different form of body pressure than other Westernised cultures, but it would be prudent to test the generalisability of the findings in other countries using validated measures.

If it were the case that the relationship between BMI and shame exists during or pre-adolescence, there would be important theoretical and research implications. Research would be warranted to understand if there is a critical age at which this relationship develops, and how it may differ from the

relationship in different age groups. There would also be obvious clinical implications for the age at which services should intervene in order to prevent a worsening of mental health in males, given the close link between shame and various mental health difficulties (Pinto-Gouveia & Matos, 2011; Troop, et al., 2008).

Strengths and limitations of the included studies.

Overall, the studies included in the current review are of very low quality, with just 5 of the 15 studies reaching above a critically low threshold of confidence in their methodological and reporting rigour. Consequently, the present review is unable to answer the question of whether there is a relationship between shame and BMI in men, and whether it differs to that found in women, with confidence. Instead, trends in the research have been illustrated with particular focus on the results of higher quality studies. There was good homogeneity between studies in terms of measuring body shame as opposed to other subtypes of shame, which helps the results of the different studies to be meaningfully compared.

There were a few limitations that were common among the studies; many failed to adequately report the selection process, showed evidence of selection bias or of using a sample not representative of the target population. Additionally, many studies altered validated outcome measures without piloting the changes or examining their validity or reliability.

The cross-sectional design of almost all the studies means that the review could not answer the deeper question of whether a causal relationship appears to exist between BMI and shame in men. Although there was a strength in the homogeneity of the type of shame measured in the studies, it also shows that this area of research is limited in its understanding of the relationship between BMI and other dimensions of shame in males. The area would benefit from high-quality research examining the relationship between the different constructs of shame (such as internal or external) with BMI in males

using a longitudinal design. If a relationship were found, this would enable conclusions to be drawn regarding whether a higher BMI leads to shame, or if shame leads to a higher BMI, for example. With obesity classed as an 'epidemic' (Mitchell, Catenacci, Wyatt & Hill, 2011), the clinical implications of understanding this relationship are clear.

Strengths and limitations of the review process.

The current review had several strengths, including a comprehensive database search, which enabled examination of all available literature in the area and a thorough and detailed assessment of the methodological and reporting quality of the included studies using a validated tool. However, there were several limitations of the current review that must be noted. First, no studies were removed from the review due to having low methodological and reporting quality. This was not done because of the large number of studies meeting the inclusion criteria that had critically low quality. If these were removed, it would leave an inadequate number of studies for a comprehensive review of the existing evidence base. Instead, the review assigned proportionate weighting to each study's findings according to their quality when interpreting them. The low quality of included studies limited the ability to answer the review aims with confidence.

Secondly, the inclusion criteria applied enabled papers to be included that directly examined BMI and shame, however this was not the focus of the study; often this examination was limited to preliminary correlational analyses that were not discussed or explained further. This limited the conclusions drawn by the study authors to explain the reasons for their findings relating to shame and BMI. As a result, the review was unable to examine these conclusions.

Thirdly, any papers that experimentally manipulated shame or BMI were excluded to maintain a focus on any naturally occurring relationship between shame and BMI. While excluding experimental studies could have limited the review's ability to establish causal links between shame and BMI, in

practice no experimental studies were found that met the other criteria. In order to answer causal questions in this field rather than merely looking at naturalistic associations, researchers would need to conduct more experimental studies on these variables, which could then be included in future reviews.

The current review aimed to examine the relationship between BMI and shame, however it may have been more prudent to choose another measure to examine body weight/size due to the unreliability of BMI to determine body composition in those with high muscle mass (Wells, Treleaven & Cole, 2007). Unlike women, men not only strive to be lean, but increasingly strive for muscularity (Leit, Pope & Gray, 2001). This is likely to be due to the ideal male body image becoming increasingly muscular (Leit, Pope & Gray, 2001), causing pressure for men to conform to this muscular body ideal. Consequently, research has found higher levels of weight stigma are experienced by men who have a BMI in both the underweight and obese categories, compared to normal BMI (Himmelstein, Puhl & Quinn, 2018). Weight stigma has been closely linked to body shame (Tomiya, 2014), which indicates that men may be more likely to experience a U-shaped relationship between body weight and shame, unlike women, who have a linear relationship between shame and BMI, whereby shame increases as BMI increases (Duarte, et al., 2015). None of the included papers that found a relationship between BMI and shame in men examined it to determine whether it was linear or non-linear. Therefore, BMI may not be the strongest source of body shame in men; lack of muscle mass may be what makes men feel socially unattractive and causes them to experience shame, and BMI may be an inadequate measure of this.

Lastly, it may be a sweeping generalisation to assume that all men have a shared ideal body size. The self-discrepancy theory postulates that shame is caused by the discrepancy between the idealised and actual self (Higgins, 1987); in this case, idealised body standard and actual body size. Differences have been found in the level of discrepancy between ideal and actual body image for men and women; men experience minimal discrepancy compared to women (Fallon & Rozin, 1985). Research supporting the

self-discrepancy theory has found that a discrepancy between the idealised body image and perceived actual body image leads to shame (Bessenoff & Snow, 2006). Therefore, future research could look at what the internalised ideal body standards are for each participant and utilise more fine-tuned measurements of body composition (such as using a combination of body callipers, height and weight measurements) to examine the amount of discrepancy between the idealised and actual body size. Examining the relationship between this discrepancy and shame may be more accurate than examining the relationship between BMI and shame in men.

Implications

Body shame has been associated with mental health problems such as disordered eating (Blythin et al., 2018). Eating disorders are more common in women than men (Pedersen et al., 2014) and research relating BMI to shame tends to focus on female samples. However, the current review suggests that there is a trend toward a positive correlation between BMI and body shame in men in the evidence base, which indicates that men should not be overlooked in this area.

This review has highlighted evidence to suggest that the relationship in men is weaker than that found in women. This different relationship may be caused by men holding different body ideals; lean muscularity (Gattario et al., 2015) as opposed to thinness. If this is the case, BMI is not the most appropriate measure of body type or size. Instead, more specific measures should be used for research, such as a combination of body callipers, height and weight measurements to determine body size and composition. Future research should focus on examining the relationship between body shame in men and the amount of discrepancy between the ideal body image and the actual body. If participants indicate the perception that their body is insufficiently muscular, this may indicate traits of muscle dysmorphic disorder (MDD; Pope, Gruber, Choi, Glivardia & Philips, 1997). MDD has been found to be associated with steroid use and suicide attempts (Pope et al., 2005). Therefore, understanding the nature of any discrepancy between the perceived actual body and idealised body

is important to help inform clinical services to understand the causes of shame in men. By understanding this, research and clinical services can refine techniques to target and reduce this experience.

The current review highlights evidence to suggest that age and sexual orientation impact the relationship between BMI and shame in men. Understanding the age at which body shame commonly develops in men is essential for services to provide the most timely and effective support to prevent a worsening of mental health. However, there has only been one study examining the impact of age on the relationship between body shame and BMI in males. This highlights that more research is required in this area to fully understand the impact age has on this relationship. Similarly, there were only three studies that examined the impact of sexual orientation on the relationship between BMI and shame in men and it was not possible to draw firm conclusions from two of these studies due to their weak methodological and reporting quality. Identifying and understanding subgroups within the population that are at greater risk of experiencing shame, and therefore mental health difficulties, is important to ensure that the most appropriate support and resources are available to them. Therefore, more methodologically robust research is required to examine the impact of men's sexual orientation on the relationship between shame and BMI.

Conclusions.

This review identifies evidence of a correlation between body shame and BMI in men. This relationship appears weaker than in women, however no firm conclusions on the difference between men and women can be drawn due to the limited quantity and largely inadequate quality of the evidence. Men's body type would be more accurately examined in future research using different measures than BMI due to its inability to differentiate between body fat and lean muscle mass. The current evidence base is lacking in studies of acceptable methodological and reporting quality and the authors recommend using caution when interpreting the results of this evidence base.

References

Ambwani, S., Chmielewski, J.F. (2013) Weighing the evidence: Social desirability, eating disorder symptomatology, and accuracy of self-reported body weight among men and women. *Sex Roles, 68*, 474-483. DOI: 10.1007/s11199-012-0244-1

American Psychiatric Association. (2000). *Diagnostic and statistical manual of mental disorders (4th ed.)*. Washington, DC. doi:10.1176/appi.books.9780890423349.

Barrett, K.C. (1995) A Functionalist Approach to Shame and Guilt. In Tangney, J.P. & Fischer, K.W., Eds., *Self Conscious Emotions: The Psychology of Shame, Guilt, Embarrassment, and Pride*, New York: The Guildford Press.

Bessenoff, G.R., Snow, D. (2006) Absorbing society's influence: Body image self-discrepancy and internalized shame. *Sex Roles, 54*, 727-731. DOI: 10.1007/s11199-006-9038-7

Blythin, S.P.M., Nicholson, H.L., Macintyre, V.G., Dickson, J.M., Fox, J.R.E., Taylor, P.J. (2018) Experiences of shame and guilt in anorexia and bulimia nervosa: A systematic review. *Psychology and Psychotherapy: Theory, Research and Practice*, 1-26. doi: 10.1111/papt.12198.

Boisvert, J.A., Harrell, W.A. (2009) Homosexuality as a risk factor for eating disorder symptomatology in men. *The Journal of Men's Studies, 17*, 210-225. DOI: 10.3149/jms.1703.210

Boisvert, J.A., Harrell, W.A. (2012) Ethnicity and spirituality as risk factors for eating disorder symptomatology in men. *International Journal of Men's Health, 11*, 36-62. DOI: 10.3149/jmh.1101.36

Brennan, M.A., Lalone, C.E., Bain, J.L (2010) Body image perceptions: Do gender differences exist? *Psi Chi Journal of Undergraduate Research, 15*, 130-138. DOI: 10.24839/1089-4136.JN15.3.130

Buote, V.M., Wilson, A.E., Strahan, E.J., Gazzola, S.B., Papps, F. (2011) Setting the bar: Divergent sociocultural norms for women's and men's ideal appearance in real- world contexts. *Body Image, 8*, 322-334. doi: 10.1016/j.bodyim.2011.06.002.

Calzo, J.P., Corliss, H.L., Blood, E.A., Field, A.E., Austin, S.B. (2013) Development of muscularity and weight concerns in heterosexual and sexual minority males. *Health Psychology, 32*(1), 42-51. <http://dx.doi.org/10.1037/a0028964>

Castonguay, A.L., Pila, E., Wrosch, C., Sabiston, C.M. (2015) Body-related self-conscious emotions relate to physical activity motivation and behaviour in men. *American Journal of Men's Health, 9*, 209-221. DOI: 10.1177/1557988314537517

Claudat, K., Warren, C.S., & Durette, R.T. (2012). The relationships between body surveillance, body shame, and contextual body concern during sexual activities in ethnically diverse female college students. *Body Image, 9*, 448–454. <http://dx.doi.org/10.1016/j.bodyim.2012.05.007>.

Cohen, J. (1988) *Statistical power analysis for the behavioural sciences (2nd edition)*. Hillsdale, NJ: Erlbaum.

Condradt, M., Dierk, J.M., Schlumberger, P., Rauh, E., Hebebrand, J., Rief, W. (2007) Development of the Weight- and Body-Related Shame and Guilt scale (WEB-SG) in a nonclinical sample of obese individuals. *Journal of Personality Assessment, 88*, 317-327. DOI: 10.1080/00223890701331856

Cook, D.R. (1990) *The Internalized Shame Scale Professional Manual*. Menomoneie, Wisconsin: Channel Press.

Crawford, D., Campbell, K. (1999) Lay definitions of ideal weight and overweight. *International Journal of Obesity and Related Metabolic Disorders, 23*, 738-745. DOI: 10.1038/sj.ijo.0800922

Daniel, S., Bridges, S.K. (2010) The drive for muscularity in men: Media influences and objectification theory. *Body Image, 7*, 32-38. doi:10.1016/j.bodyim.2009.08.003

Downes, M.J., Brennan, M.L., Williams, H.C., Dean, R.S (2016). Development of a critical appraisal tool to assess the quality of cross-sectional studies (AXIS). *BMJ Open, 6*, 1-7. doi:10.1136/bmjopen-2016-011458

Duarte, C., Matos, M., Stubbs, R.J., Gale, C., Morris, L., Pinto-Gouveia, J., Gilbert, P. (2017) The impact of shame, self-criticism and social rank on eating behaviours in overweight and obese women participating in a weight management programme. *PLoS ONE*, *12*, 1-14. doi:10.1371/journal.pone.0167571

Duarte, C., Pinto-Gouveia, J., Ferreira, C., & Batista, D. (2015). Body image as a source of shame: A new measure for the assessment of the multifaceted nature of body image shame. *Clinical Psychology and Psychotherapy*, *22*, 656-666. doi:10.1002/cpp.1925

Dumitrescu, A.L., Dogaru, C.B, Duta, C., Manolescu, B. (2011) Body weight, shame, guilt and oral health: A path analysis model in undergraduate students. *Romanian Journal of Internal Medicine*, *49*, 281-288.

Fallon, A.E., Rozin, P. (1985) Sex differences in perceptions of desirable body shape. *Journal of Abnormal Psychology*, *94*, 102-105. <http://dx.doi.org/10.1037/0021-843X.94.1.102>

Ferreira, C., Pinto-Gouveia, J., Duarte, C. (2013) Drive for thinness as a women's strategy to avoid inferiority. *International Journal of Psychology & Psychological Therapy*, *13*, 15-29.

Furnham, A., Badmin, N., Sneade, I. (2002) Body image dissatisfaction: Gender differences in eating attitudes, self-esteem, and reasons for exercise. *The Journal of Psychology*, *136*, 581-596. DOI: 10.1080/00223980209604820

Gattario, H.K, Frisén, A., Fuller-Tyszkiewicz, M., Ricciardelli, L.A., Diedrichs, P.C., Yager, Z., Smolak, L., Franko, D., Smolak, L. (2015). How is men's conformity to masculine norms related to their body image? Masculinity and muscularity across Western countries. *Psychology of Men and Masculinities*, *16*, 337-347 <http://dx.doi.org/10.1037/a0038494>

Gilbert, P. (1997) The evolution of social attractiveness and its role in shame, humiliation, guilt and therapy. *British Journal of Medical Psychology*, *70*, 113-147. DOI: 10.1111/j.2044-8341.1997.tb01893.x

- Gilbert, P. (2002) Body Shame: A Biopsychosocial conceptualisation and overview, with treatment implications. In Gilbert, P. & Miles, J., Eds., *Body Shame: Conceptualisation, Research, and Treatment*. New York: Brunner-Routledge. <https://doi.org/10.4324/9781315820255>
- Goss, K., Gilbert, P., & Allan, S. (1994). An exploration of shame measures - I: The Other as Shamer Scale. *Personality and Individual Differences*, 17, 713–717. [http://dx.doi.org/10.1016/0191-8869\(94\)90149-X](http://dx.doi.org/10.1016/0191-8869(94)90149-X).
- Hatoum, I.J., Bell, D. (2004) Mags and abs: Media consumption and bodily concerns in men. *Sex Roles*, 51, 397-407. <https://doi.org/10.1023/B:SERS.0000049229.93256.48>
- Higgins, E.T. (1987) Self-discrepancy: A theory relating self and affect. *Psychological Review*, 94, 319-340. <http://dx.doi.org/10.1037/0033-295X.94.3.319>
- Himmelstein, M., Tomiyama, J. (2015) It's not you, it's me: Self-perceptions, antifat attitudes, and stereotyping of obese individuals. *Social Psychological and Personality Science*, 6, 749-757. <https://doi.org/10.1177/1948550615585831>
- Jambekar, S.A., Masheb, R.M., Grilo, C.M. (2003) Gender differences in shame in patients with binge-eating disorder. *Obesity Research*, 11, 571-577. DOI: 10.1038/oby.2003.80
- Knauss, C., Paxton, S.J., Alsaker, F.D. (2008) Body dissatisfaction in adolescent boys and girls: Objectified body consciousness, internalization of the media body ideal and perceived pressure from media. *Sex Roles*, 59, 633-643. DOI 10.1007/s11199-008-9474-7
- Leit, R.A., Pope, H.G., Gray, J.J. (2001) Cultural Expectations of Muscularity in Men: The Evolution of Playgirl Centerfolds. *International Journal of Eating Disorders*, 29, 90-93. [https://doi.org/10.1002/1098-108X\(200101\)29:1<90::AID-EAT15>3.0.CO;2-F](https://doi.org/10.1002/1098-108X(200101)29:1<90::AID-EAT15>3.0.CO;2-F)
- Marta-Simoes, J., Ferreira, C., Mendes, A.L. (2016) Exploring the effect of external shame on body appreciation among Portuguese young adults: The role of self-compassion. *Eating Behaviors*, 23, 174-179. <http://dx.doi.org/10.1016/j.eatbeh.2016.10.006>

Martins, Y., Tiggemann, M., Kirkbride, A. (2007) Those Speedos become them: The role of self-objectification in gay and heterosexual men's body image. *Personality and Social Psychology Bulletin*, 33, 634-647. DOI: 10.1177/0146167206297403

Mascolo, M.F. & Fischer, K.W. (1995) Developmental Transformations in Appraisals for Pride, Shame, and Guilt. In Tangney, J.P. & Fischer, K.W., Eds., *Self Conscious Emotions: The Psychology of Shame, Guilt, Embarrassment, and Pride*, New York: The Guildford Press.

Mason, T.B., Lewis, R.J. (2015) Assessing the roles of impulsivity, food-related cognitions, BMI, and demographics in the dual pathway model of binge eating among men and women. *Eating Behaviours*, 18, 151-155. <http://dx.doi.org/10.1016/j.eatbeh.2015.05.015>

Matos, M., Pinto-Gouveia, Gilbert, P., Duarte, C., Figueiredo, C. (2015) The Other As Shamer Scale – 2: Development and validation of a short version of a measure of external shame. *Personality and Individual Differences*, 74, 6-11. <https://doi.org/10.1016/j.paid.2014.09.037>

McFarland, M., Petrie, T. (2012). Male body satisfaction: Factorial and construct validity of the Body Parts Satisfaction Scale for men. *Journal of Counselling Psychology*, 59, 329-337. doi: 10.1037/a0026777.

McKinley, N.M., Hyde, J.S. (1996) The Objectified Body Consciousness Scale development and validation. *Psychology of Women Quarterly*, 20, 181-215.

Mitchell, N., Catenacci, V., Wyatt, H.R., Hill, J.O. (2011) Obesity: Overview of an epidemic. *Psychiatric Clinics of North America*. *Psychiatric Clinics of North America*, 34, 717-732. doi: 10.1016/j.psc.2011.08.005

Moher, D., Liberati, A., Tetzlaff, J., & Altman, D. (2009). Preferred reporting items for systematic reviews and meta-analysis: The PRISMA statement. *International Journal of Surgery*, 8, 336-341. doi: 10.1136/bmj.b2535

Oliveira, S., Trindade, I., Ferreria, C. (2018) Explaining male body attitudes: The role of early peer emotional experiences and shame. *Eating and Weight Disorders*, 23, 807-815. <https://doi.org/10.1007/s40519-018-0569-z>

Pedersen, C.B., Mors, O., Bertelsen, A., Walktoft, B.L., Agerbo, E., McGrath, J.J., Mortensen, P.B., Eaton, W.W. (2014) A comprehensive nationwide study of the incidence rate and lifetime risk for treated mental disorders. *JAMA Psychiatry*, 71, 573-581. doi:10.1001/jamapsychiatry.2014.16

Pinto-Gouveia, J., Matos, M. (2011) Can shame memories become a key to identity? The centrality of shame memories predicts psychopathology. *Applied Cognitive Psychology*, 25, 281-290. <https://doi.org/10.1002/acp.1689>

Pope, C.G., Pope, H.G., Menard, W., Fay, C., Olivardia, R., Phillips, K.A. (2005) Clinical features of muscle dysmorphia among males with body dysmorphic disorder. *Body Image*, 2, 395-400. doi: 10.1016/j.bodyim.2005.09.001

Pope, H.G., Gruber, A.J., Choi, P., Olivardia, R., Phillips, K.A. (1997) Muscle Dysmorphia: An underrecognized form of Body Dysmorphic Disorder. *Psychosomatics*, 38, 548-557 [https://doi.org/10.1016/S0033-3182\(97\)71400-2](https://doi.org/10.1016/S0033-3182(97)71400-2)

Rieger, G., Linsenmeier, J.A.W., Gygax, L., Bailey, J.M. (2008) Sexual orientation and childhood gender nonconformity: Evidence from home videos. *Developmental Psychology*, 44, 46-58. DOI: 10.1037/0012-1649.44.1.46

Rollero, C., Gattiano, S., De Piccoli, N. Fedi, A. (2018) Protective versus risk factors for self-objectification in different age and gender cohorts. *Psihologija*, 51, 17-30. DOI: <https://doi.org/10.2298/PSI161222008R>

Shea, B.J., Reeves, B.C., Wells, G., Thuku, M., Hamel, C., Moran, J., Moher, D., Tugwell, P., Welch, V., Kristjansson, E., Henry, D. (2017) AMSTAR 2: A critical appraisal tool for systematic reviews that include

randomised or non-randomised studies of healthcare interventions, or both. *Research Methods and Reporting*, 358, 1-9. doi: 10.1136/bmj.j4008

Strong, S. M., Williamson, D. A., Netemeyer, R. G., Greer, J. H. (2001). Eating disorder symptoms and concerns about body differ as a function of gender and sexual orientation. *Journal of Social and Clinical Psychology*, 19, 240 – 255. <http://dx.doi.org/10.1521/jscp.2000.19.2.240>

Tangney, J.P. (1995) Shame and Guilt in Interpersonal Relationships. In Tangney, J.P. & Fischer, K.W., Eds., *Self Conscious Emotions: The Psychology of Shame, Guilt, Embarrassment, and Pride*, New York: The Guildford Press.

Thompson, J. K., Heinberg, L., Altabe, M., & Tantleff-Dunn, S. (1999). Exacting Beauty: Theory, assessment, and treatment of body image disturbance. *Washington, DC: American Psychological Association*. <http://dx.doi.org/10.1037/10312-000>

Tiggemann, M., Martins, Y., & Kirkbride, A. (2007). Oh to be lean and muscular: Body image ideals in gay and heterosexual men. *Psychology of Men & Masculinity*, 8, 15-24. <http://dx.doi.org/10.1037/1524-9220.8.1.15>

Tomiya, A.J. (2014) Weight stigma is stressful. A review of evidence for the Cyclic Obesity/Weight-Based Stigma model. *Appetite*, 82, 8-15. DOI 10.1016/j.appet.2014.06.108

Troop, N. A., Allan, S., Serpell, L., & Treasure, J. L. (2008). Shame in women with a history of eating disorders. *European Eating Disorders Review*, 16, 480–488. doi: 10.1002/erv.858

Troop, N.A., Redshaw, C. (2012) General shame and bodily shame in eating disorders: A 2.5 year longitudinal study. *European Eating Disorders Review*, 20, 373-378. DOI: 10.1002/erv.2160

Tylka, T.L. (2013) Evidence for the Body Appreciation Scale's measurement equivalence/invariance between U.S. college women and men. *Body Image*, 10, 415-418. <http://dx.doi.org/10.1016/j.bodyim.2013.02.006>

Tylka, T.L., Kroon, A.M. (2013) The Intuitive Eating Scale-2: Item refinement and psychometric evaluation with college women and men. *Journal of Counseling Psychology*, 60, 137-153. DOI: 10.1037/a0030893

Wells, J.C.K., Treleaven, P., Cole, T.J. (2007) BMI compared with 3-dimensional body shape: The UK National Sizing Survey. *The American Journal of Clinical Nutrition*, 85, 419-425. <https://doi.org/10.1093/ajcn/85.2.419>

Wiseman, M.C., Moradi, B. (2010) Body image and eating disorder symptoms in sexual minority men: A test and extension of objectification theory. *Journal of Counseling Psychology*, 57, 154-166. DOI: 10.1037/a0018937

Paper 2 has been prepared in line with author guidelines for submission to Psychology and Psychotherapy journal (Appendix A). Tables and figures have been included in the main manuscript for reader clarity. For journal submission, these will be put at the end of the manuscript, as per journal guidelines.

Paper 2: Does perfectionism continue to predict disordered eating when shame is controlled for?

Word count (excluding tables/figures): 4,208

Abstract

Objectives. Both shame and perfectionism are seen as core mechanisms underlying disordered eating. However, there is no research examining the relationship between these two mechanisms in this context. This study aimed to examine the relationship between shame and perfectionism in disordered eating, and specifically, whether perfectionism mediates the predictive relationship between shame and disordered eating. **Design.** A longitudinal digital questionnaire study with a community sample. **Methods.** A community sample of 149 adults completed questionnaires assessing internal shame, external shame, self-oriented perfectionism and socially prescribed perfectionism (independent variables) and disordered eating attitudes and behaviours (dependent variable) once at baseline (T1) and again after six months (T2). **Results.** All measures of shame and perfectionism were positively correlated with disordered eating. T1 socially prescribed perfectionism was the only independent variable that significantly predicted disordered eating at T2 when disordered eating at T1 was controlled. Therefore, mediation analysis was not indicated. **Conclusions.** This study indicates that although shame and perfectionism are correlated with disordered eating, only socially prescribed perfectionism predicts variance in disordered eating. As the variance predicted by socially prescribed perfectionism was small, further research into this area is warranted to better understand this relationship. The failure to detect a predictive relationship between shame and disordered eating was unexpected and future research using measures of shame that are more specific to the body (i.e. body shame) may help clarify this relationship. This study identified the need to compare the relationship between perfectionism and disordered eating behaviour in clinical and non-clinical groups.

Keywords

Disordered eating, eating disorders, internal shame, external shame, self-oriented perfectionism, socially prescribed perfectionism, CBT-E, CFT-E.

Practitioner Points

- Socially prescribed perfectionism may play a role in predicting future disordered eating attitudes and behaviours
- Research must use longitudinal methodology and control for baseline levels of disordered eating when examining the core mechanisms underlying it
- Measures of shame specific to the body (i.e. examining body shame) should be used when examining the predictive relationship between shame and disordered eating.

Introduction

Classification of Eating Disorders (EDs).

There is debate regarding the clinical utility of diagnostic categorisation of EDs and consensus is growing for shared mechanisms within a transdiagnostic model (e.g. Fox and Power 2009; 2012). Fairburn, Cooper, and Shafran (2003) propose that these shared mechanisms can be expressed in different ways, leading to different disordered eating presentations. These researchers argue that understanding the relationship between these core shared mechanisms and disordered eating can help us understand the factors driving different ED presentations (Fairburn, Cooper & Shafran, 2003).

Goss and Gilbert (2002) consider shame a core element for the development and maintenance of disordered eating, and empirically, shame significantly predicts EDs (Troop, Allan, Serpell & Treasure, 2008). A second psychological construct that has been linked to disordered eating is perfectionism; striving for the ideal body type is often seen as inherently perfectionistic (Goldner, Cockell & Srikaneswaran, 2002). Indeed, those with EDs have been found to have higher levels of perfectionism (Bardone-Cone et al., 2007), and perfectionism is considered a maintaining factor across EDs (Fairburn, Cooper & Shafran, 2003). However, the relationship between shame and perfectionism in disordered

eating has not been empirically examined before. The concepts of shame and perfectionism and their relation to EDs will now be considered in more detail.

Shame and Eating Disorders.

Shame is a self-conscious emotion characterised by a sense of inadequacy and possessing undesirable attributes (Goss & Gilbert, 2002). The individual fears that their undesirable attributes will lead to social rejection or diminishment (Barrett, 1995). Shame is commonly conceptualised as multidimensional and can be separated into internal shame and external shame; whereas internal shame is the perception of oneself as bad, inadequate or disgusting (Gilbert, 1998), external shame relates to the belief that the self possesses attributes that *others* see as bad, inadequate or disgusting and which may cause social rejection (Goss & Gilbert, 2002).

Gilbert's (1997) evolutionary account of shame proposes that it is an emotional device to identify personal attributes that should remain hidden to avoid being seen as unattractive to others ('socially unattractive'), thus preventing social rejection. Therefore, if an individual does not consider their body to match the socially attractive body image (thin or lean for Western cultures; Thompson, Heinberg, Altabe & Tantleff-Dunn, 1999) they are likely to experience shame. After an individual experiences shame, their disordered eating behaviour increases (Kelly & Tasca, 2016), which supports the notion that shame involves a desire to change or conceal socially unattractive attributes (Gilbert, 2002).

ED groups have higher levels of shame compared to other clinical populations (Kelly & Carter, 2013). Indeed, within the ED population, rising levels of shame are associated with increased ED symptomatology and severity (Troop, et al., 2008). Troop et al. (2008) found that the severity of bulimic symptoms was exclusively associated with internal shame, whereas the severity of anorexic symptoms was exclusively associated with external shame. Although both internal and external shame were lower for those who were in remission from their ED compared to an active ED sample,

their external shame remained higher than a non-clinical sample. The study found no difference in internal shame levels between those in remission and the non-clinical group. This study highlights the differing roles internal and external shame may play within disordered eating.

Shame and pride cycles are models of understanding the roles of internal and external shame in relation to disordered eating. It suggests that these different dimensions of shame lead to different behavioural responses (restricting and bingeing; Goss & Gilbert, 2002).

Shame and Pride Cycles in Eating Disorders.

The model of eating disorder development and maintenance outlined by Goss and Gilbert (2002) is based on shame and pride. It proposes that an initial shaming experience (i.e. external shame) leads an individual to engage in behaviours, such as food restriction, to increase feelings of pride by pursuing a 'perfect' body. This pride in the perfectionistic striving for a socially desirable body image has been proposed as a maintaining factor for the restricting behaviour (Faija, Tierney, Gooding, Peters & Fox, 2017). However, according to Goss and Gilbert, when food restriction fails and the perfectionistic individual does not match their idealised body image, they experience internal shame, resulting in further attempts to gain pride via food restriction. These researchers propose that this shame-pride cycle is key to the maintenance of restrictive behavioural patterns in eating disorders.

According to Goss and Gilbert's (2002) model, other individuals may attempt to regulate the external shame that arises from a shaming experience by bingeing. However, both bingeing and subsequent purging extend the feelings of internal shame, leading to further attempts to regulate emotions with bingeing. This is known as the shame-shame cycle and is thought to maintain binge-purge behavioural patterns in disordered eating (Goss & Gilbert, 2002).

Perfectionism and Eating Disorders.

Individuals who exhibit clinical perfectionism are thought to base their self-worth judgements on their attainment of excessively demanding standards or goals, and their success in attaining them (Frost, Marten & Rosenblate, 1990). Perfectionism is a core mechanism in EDs as individuals strive towards the attainment of an unobtainable 'perfect' body image or weight standard that has been set by themselves or others (Fairburn, Cooper & Shafran, 2003).

Like shame, perfectionism has been conceptualised as a multidimensional construct including a self-oriented dimension, in which expectations of perfection are self-imposed, and a socially prescribed dimension, which refers to the belief that others are imposing perfectionistic expectations onto the self (Hewett & Flett, 1991). Both self-oriented and socially prescribed perfectionism have been found to be related to ED symptomatology (Castro-Fornieles et al., 2007). Indeed, researchers have demonstrated that perfectionism predicts ED onset (Bardone-Cone, Abramson, Vohs, Heatherton & Joiner, 2006), and the transdiagnostic model proposes that clinical perfectionism can be a maintaining factor in EDs (Fairburn, Cooper & Shafran, 2003). The relationship between perfectionism and EDs indicates that ED behaviour can be attributed to a need to conform to a perfect body image that can be self-imposed or perceived as expected by others.

Hamacheck (1978) proposed that perfectionism and shame are linked, in that the perfectionistic individual has a heightened fear of failure and both seeks approval and avoids the shame associated with disapproval through perfect performance. Given the importance that the current predominant treatment for EDs (Enhanced Cognitive Behavioural Therapy; CBT-E; Fairburn, 2008) places on resolving clinical perfectionism, it seems pertinent to establish the extent to which shame and perfectionism have predictive value independently of one another. Furthermore, establishing whether there is any causal relationship in which shame leads to perfectionism (as indicated in Hamacheck's model; 1978), and how this causal process might lead to disordered eating is warranted.

One possibility is that shame has a causal role in the development of an ED, but that this is largely mediated by increases in perfectionism.

Clarifying the relationship between shame and perfectionism in the context of disordered eating will be informative for treatments, in particular for providing more conceptual grounding for treatments such as CBT-E, or Compassion Focused Therapy for Eating Disorders (CFT-E), which has already shown promising results in the treatment of EDs (e.g., Gale, Gilbert, Read & Goss, 2014).

Aim of the Current Study.

The current study aims to examine whether shame and perfectionism are predictive of ED symptoms when baseline ED symptoms are controlled, and whether perfectionism mediates the relationship between shame and ED symptoms.

Key Hypotheses:

When controlling for disordered eating (Eating Disorder Examination Questionnaire; EDEQ) at Time point 1 (T1):

1. Internal shame at T1 (Personal Feelings Questionnaire; PFQ) significantly predicts disordered eating at Time point 2 (T2)
2. External shame at T1 (Other as Shamer Scale; OAS) significantly predicts disordered eating at T2
3. Self-oriented perfectionism at T1 (Multi-Dimension Perfectionism Scale Self subscale; MPS Self) significantly predicts disordered eating at T2
4. Socially prescribed perfectionism at T1 (Multi-Dimension Perfectionism Scale Social subscale; MPS Social) significantly predicts disordered eating at T2

Subsidiary Hypotheses:

To explore whether:

1. Internal or external shame (measured by T1 PFQ and T1 OAS, respectively) have different relationships with disordered eating (measured by T2 EDEQ) when baseline disordered eating (T1 EDEQ) is controlled for.
2. The influence of shame (PFQ and OAS) on disordered eating (EDEQ) operates via perfectionism (MPS Self and MPS Social) as a mediator.

Methodology

Participants.

A community sample of 908 adults took part in the first stage of the digital questionnaire study (T1). Participants were excluded from the analysis if they a) failed to complete one or more entire questionnaires, or b) did not provide a phone number for researchers to invite them to T2. Of the remaining 516 participants, 225 responded to a text reminder to take part in T2. Participants were excluded from the final analysis if; a) they failed to fully complete all questionnaires, b) their T1 and T2 responses could not be matched by ID code, c) they participated in either T1 or T2 more than once (their first full set of responses was included and all other responses excluded). The final sample included 149 adults; 124 females and 25 males ranging in age from 18-70 ($M= 35.4$ years, $SD= 12.17$). The final sample had a BMI ranging from 15 to 50 ($M=24.59$, $SD=5.14$). The mean BMI of the sample was lower than the mean for England and Wales (NHS Digital, 2017; Welsh Government, 2019), and would be classified as 'normal' (World Health Organization, 1995). 85.23% of the sample scored higher than the accepted clinical threshold indicating the presence of an eating disorder (a score of 2.3 on the EDEQ Global subscale; Mond, Hay, Rodgers, Owen, and Beumont; 2004). This is higher than

the 25% that has previously been found in a community sample (Mond, Hay, Rodgers and Owen, 2006).

There was no significant difference in the gender of the sample at T1 and T2 ($t(660) = 0.06, p = .95$) but the average age of the sample at T2 was significantly higher than T1 ($t(562) = 13.61, p < .01$). The difference in the country of origin between the samples in T1 and T2 is detailed in Table 2. It is apparent that despite a broad range of different countries of origin at T1, at T2 almost all the sample are British.

Table 1

Country of origin of T1 and T2 sample.

Country of origin	Number of participants	
	T1	T2
UK	154	61
England	89	39
Wales	86	36
USA	37	0
Scotland	16	7
Canada	5	0
Ireland	3	3
Northern Ireland	3	1
Australia	2	0
Turkey	2	0
Latvia	1	1
Israel	1	1

Country of origin	Number of participants	
	T1	T2
Nepal	1	0
New Zealand	1	0
India	1	0
Belgium	1	0
Cyprus	1	0
South Africa	1	0
United Arab Emirates	1	0
Netherlands	1	0
China	1	0
Malaysia	1	0
Missing information	107	0

Recruitment.

Ethical approval was obtained by Cardiff University School of Psychology Ethics Committee. Power calculations using G*Power (Faul, Erdfelder, Buchner & Lang, 2009) indicated a sample of 77 participants were required at T2 to detect a medium effect with a power of 0.8 (as recommended by Cohen, 1988) using a linear multiple regression test with up to 5 predictors. To protect against the expected dropout of up to 75% in T2 (e.g Troop & Redshaw, 2012), a larger sample size was sought for T1.

Participants were recruited for T1 via advertising on various social media forums and groups. An invitation to take part in the study was posted in approximately 70 groups on Facebook, and in tweets

on a bespoke study Twitter page. A range of groups were chosen for advertisement on Facebook; related to food/eating and general interest. All participants were entered into a prize draw for £40 Amazon vouchers in return for their participation. Additionally, the Qualtrics study was advertised through the Cardiff University Electronic Management System (EMS), in which current Cardiff University students complete research in return for course credits. EMS participants were also entered into the prize draw.

For T2, all T1 participants were sent a text message 6 months after their completion of T1 and were advised of a second prize draw for £40 Amazon vouchers in return for their participation in T2. The text contained a link to the study, which was a copy of the original T1 questionnaire study. Any participants who began to respond to the study but did not complete it were sent a text message after one week inviting them to continue. Post hoc power calculations using G*Power (Faul, et al., 2009) indicated that the study had over 80% power to detect effect sizes of 0.9.

Measures.

Eating Disorder Examination Questionnaire (EDEQ; Fairburn & Beglin, 1994).

Eating disorder symptomatology was measured with the EDEQ (Fairburn & Beglin, 1994), which is a 28-item self-report instrument that is widely used to assess disordered eating attitudes and behaviours in both clinical and community samples. The Global subscale of the EDEQ was used in the current study to represent disordered eating scores and demonstrated strong test-retest reliability ($r = .83, p < .001$). The Cronbach's alpha for this subscale was .917, $n = 4$ at T1, and .915, $n = 4$ at T2, which is indicative of excellent internal consistency.

Personal Feelings Questionnaire, version 2 (PFQ; Harder & Zalma, 1990).

Internal shame was measured with the PFQ (Harder & Zalma, 1990). The 10-item PFQ shame subscale was analysed in isolation, as recommended by Harder, Rockart and Cutler (1993). The Cronbach's alpha for the PFQ Shame subscale in the current study was .825, $n=10$ for T1, and .806, $n=10$ for T2, which indicates good internal consistency. The subscale also demonstrated strong test-retest reliability ($r= .73, p<.001$).

The Other as Shamer Scale (OAS; Goss, Gilbert & Allan, 1994).

The OAS (Goss, Gilbert & Allan, 1994) is an 18-item questionnaire, which was used to measure participants' external shame. The Cronbach's alpha for OAS in the current study was .948, $n=18$ at T1, and .958, $n=18$ at T2, which indicates excellent internal consistency. The measure showed strong test-retest reliability ($r= .75, p<.001$).

Multi-Dimension Perfectionism Scale (MPS; Hewett & Flett, 1990) .

The MPS (Hewett & Flett, 1990) was used to examine traits of perfectionism. This is a 45-item measure that examines three dimensions of perfectionism; self-oriented, other-oriented and socially prescribed perfectionism. To test the hypotheses of the current study, Self-oriented and Socially prescribed subscales were examined. The MPS subscale Cronbach's alpha scores for the current study can be seen in Table 1. The internal consistency for the Self-oriented subscale is just under a sufficient level according to Nunnally (1978). Previous research has found excellent internal consistency for the Socially Prescribed subscale ($\alpha=.87$ in Hewitt & Flett, 1991), but the current study found it to be at a questionable level. However, in order to retain adequate content validity, none of the items were removed. The MPS Self subscale demonstrated strong test-retest reliability ($r= .741, p<.001$), and the MPS Social subscale showed moderate test-retest reliability ($r= .650, p<.001$).

Table 2

Cronbach's alpha scores for MPS Subscales and Pearson's Correlation Coefficient at T1 and T2.

Subscale	Number of Items	T1 α	T2 α	<i>r</i>
Self	15	.703	.690	.74***
Social	15	.606	.653	.65***

Note. *** $p < .001$

Study procedure.

When participants successfully entered the password, they were presented with:

- 1) Participant information sheet
- 2) Consent form
- 3) Request for phone number and identifier code
- 4) Demographics questions
- 5) Questionnaires (all questionnaires were digitalised in Qualtrics (Qualtrics, Provo, UT) and had forced response answers. The order of presentation was randomised for each participant.)
- 6) Debrief sheet.

Six months after the completion of T1, participants were sent a text inviting them to complete T2. The text contained a direct link to the T2 study. The procedure for T2 was the same as T1.

Analysis.

All analyses were completed using SPSS 25.0 (SPSS Inc., Armonk, NY, USA) for Windows. Preliminary analyses indicated that these data were suitable for regression analyses following the assumptions of normality, linearity, homoscedasticity, and independence of errors (Field, 2009).

Following correlational analysis, a multiple regression was used to determine whether shame (internal and external) and perfectionism (self-oriented and socially prescribed) significantly predicted disordered eating when disordered eating was controlled for at T1. This regression was also used to examine whether internal and external shame have differing relationships with disordered eating (subsidiary hypothesis). T1 EDEQ scores were controlled by entering this as an independent variable in the first step of the multiple regression. Shame (T1 PFQ and T1 OAS) and perfectionism (T1 MPS Social and T1 MPS Self) were then entered into subsequent steps as independent variables to predict residual variance in T2 EDEQ.

As illustrated in Figures 1-4, four two-wave longitudinal mediation regression models (Jose, 2013) were intended to be used to test the second subsidiary hypothesis by examining the effect of self-oriented and socially prescribed perfectionism as mediators on the relationship between shame (internal and external) and disordered eating. Sobel tests were planned to test the significance of the indirect (*b*) path within these mediation models.

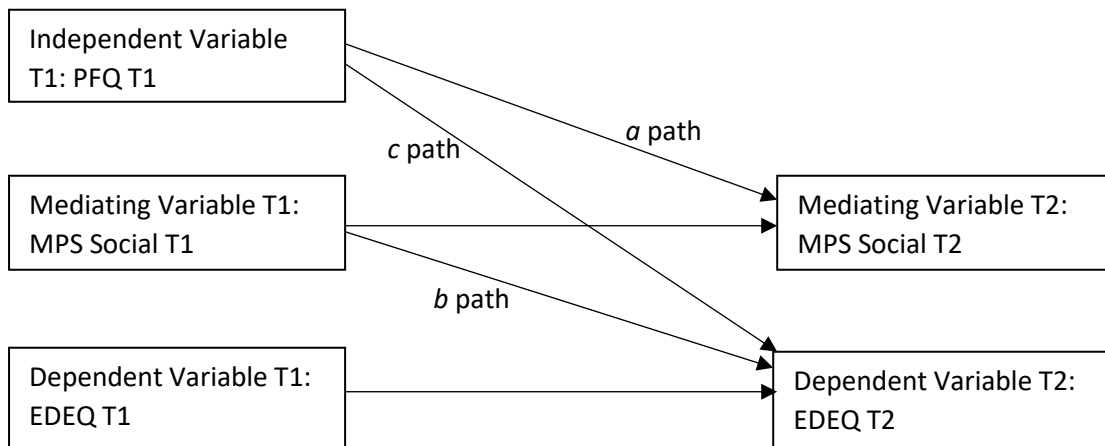

Figure 1. Two-wave mediation Model 1

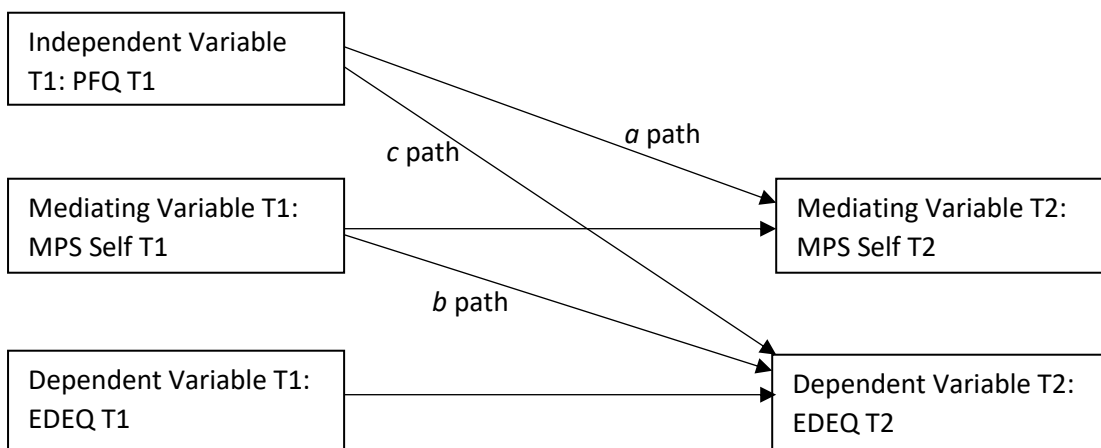

Figure 2. Two-wave mediation Model 2

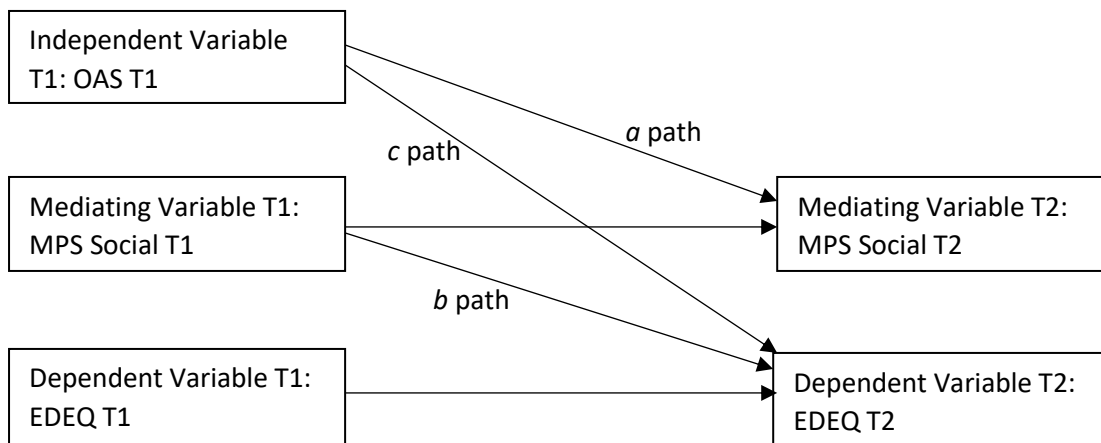

Figure 3. Two-wave mediation Model 3

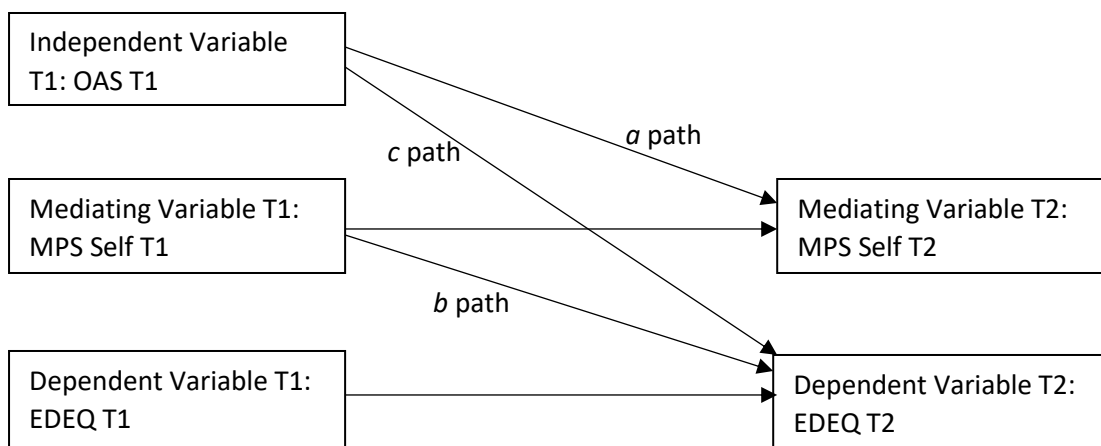

Figure 4. Two-wave mediation Model 4

Results

Correlations between independent and dependent variables.

Pearson's correlations between T1 independent variables and the dependent variable (T2 disordered eating) are reported in Table 2. Shame was significantly correlated with disordered eating with medium effect sizes (Cohen, 1988); internal shame $r = .52, p < .001$, external shame $r = .59, p < .001$. Perfectionism was significantly correlated with disordered eating with medium effect sizes; self-oriented perfectionism $r = .43, p < .001$, socially prescribed perfectionism $r = .40, p < .001$. Disordered eating at T1 was significantly correlated with disordered eating at T2 with a large effect size, $r = .84, p < .001$.

Table 3

Pearson's Correlation Scores for All Independent Variables with EDEQ

T1 variables correlated with EDEQ Global (T2)	<i>r</i>
PFQ	.520***
OAS	.585***
MPS Self	.430***
MPS Social	.404***
EDEQ	.842***

Note. *** $p < .001$

Multiple regression analysis.

Multiple regressions were calculated to determine which independent variables at T1 predict disordered eating at T2. To control for the effect of T1 EDEQ, this was entered first into a hierarchical multiple regression, followed by each of the independent T1 variables (PFQ, OAS, MPS Self and MPS Social). As shown in Table 3, T1 EDEQ was the largest predictor of T2 EDEQ scores ($t(146) = 16.95, p < .001$) as expected, with an R^2 of .71. T1 MPS Social predicted T2 EDEQ when T1 EDEQ was controlled for ($t(146) = 2.22, p < .05$), with a change in R^2 of .01. Therefore, Hypothesis 4, that socially prescribed

perfectionism at T1 significantly predicts disordered eating at T2 when disordered eating at T1 is controlled for, is accepted. No other variables showed a significant predictive effect on disordered eating at T2, which means all other key hypotheses were rejected.

Table 4

Hierarchical Multiple Regression Coefficients for All Significant Predictors of T2 EDEQ

		<i>b</i>	<i>SE</i>	β	<i>t</i>
Step 1	Constant	1.35	0.63		2.14*
	T1 EDEQ	0.836	0.04	.84***	18.91***
Step 2	Constant	-3.90	2.45		-1.59
	T1 EDEQ	0.80	0.05	.80***	16.95***
	T1 MPS Social	0.09	0.04	.11*	2.22*

Note. *b*= beta value, *SE*= Standard error, β = standardised beta value, $R^2= .71$ for Step 1, $\Delta R^2= .01$ for Step 2 ($p<.05$). * $p<.05$, *** $p<.001$

Neither internal shame nor external shame predicted disordered eating. Therefore, the first subsidiary hypothesis, that internal and external shame have different relationships with disordered eating at T2 when disordered eating at T1 is controlled for, is also rejected.

As MPS Social was the only T1 variable that significantly predicted T2 EDEQ when T1 EDEQ was controlled for, these results did not support the use of a mediation regression analysis to test the second subsidiary hypothesis. The data did not fit a mediational model, so no further analyses were conducted and the hypothesis that perfectionism significantly mediates the relationship between shame at T1 and disordered eating at T2 is rejected.

Discussion

The present study extended previous research by examining the roles of shame and perfectionism in predicting disordered eating longitudinally. The study aimed to examine whether perfectionism mediates the predictive relationship between shame and EDs. However, after controlling for baseline levels of ED symptomatology, neither internal nor external shame significantly predicted ED so there was insufficient support for this mediational model. Self-oriented perfectionism also failed to predict ED longitudinally. However, socially prescribed perfectionism significantly predicted ED symptomatology at six-month follow up, after baseline ED was controlled.

Implications.

The model of shame-pride and shame-shame cycles suggests that the experience of shame is central to the development and maintenance of EDs (Goss & Gilbert, 2002). Interestingly the present study provides only limited evidence to support this theory, as shame and disordered eating were significantly correlated, however no predictive relationship was found. This finding is consistent with previous longitudinal research (Troop & Redshaw, 2012), which found no significant predictive effect of either internal or external shame on disordered eating when baseline disordered eating was controlled for.

One possible reason for the present study's failure to find a significant predictive relationship between shame and disordered eating is that there may be a more specific source of shame that predicts disordered eating, such as body shame. Body shame refers to shame relating specifically to the body appearance and functioning (Gilbert, 2002) and as such may be more specific to EDs. Indeed, when using a specific body shame measure, Troop and Redshaw (2012) identified body shame as a significant predictor of disordered eating in their longitudinal study. Internal and external shame were examined in the present study as one of the analyses of interest concerned the link between shame

and perfectionism. It was thought that these general measures of shame would correlate better with the self-oriented and socially prescribed perfectionism subscales, rather than a more specific measure concerning body shame. However, in future research, measures specifically examining shame relating to body appearance and functioning may be able to more accurately detect a predictive effect of shame on disordered eating.

The present study found evidence to suggest that socially prescribed perfectionism predicts disordered eating. Although it would be rash to draw firm conclusions from this finding as the variance predicted was very small, the significance of the finding justifies further research into this relationship. The significant predictive relationship of socially prescribed perfectionism but not self-oriented perfectionism on EDs illustrates the importance of examining socially prescribed perfectionism independently from other dimensions of perfectionism to avoid distorting or suppressing its independent relationship with disordered eating.

The predictive role indicated for socially prescribed perfectionism but not self-oriented perfectionism in EDs in the present study may be explained with the self-determination theory of motivation (Deci & Ryan, 2002). This theory proposes that the internalisation of externally motivated activities can only happen when the individual feels competent in these activities. If this happens before the individual feels competent, the process of internalisation of motivation is unsuccessful. Instead, the individual takes in the motivation, but fails to consider it their own. When applied to socially prescribed perfectionism and EDs, this theory suggests that socially prescribed perfectionism is likely to motivate disordered eating behaviours initially, until the individual feels competent. The next stage of internalising the perceived perfectionistic expectations of the other (leading to self-oriented perfectionism) may not have occurred in the current study's non-clinical sample, as they have not reached the stage of feeling 'competent' in the behaviours. According to this theory, the internalisation of the socially prescribed perfectionistic standard is more likely to have occurred in a clinical sample, whose disordered eating behaviour is more established. Understanding whether

there is a difference between clinical and non-clinical samples in whether self-oriented perfectionism predicts disordered eating behaviours has important theoretical, clinical and research implications.

Evidence from longitudinal studies suggests that perfectionism predicts EDs, however much of this research examines perfectionism with a unidimensional measure (Eating Disorder Inventory-Perfectionism subscale; Garner, Olmstead & Polivy, 1983; e.g. Bardone-Cone et al., 2006; Holland, Bodell & Keel, 2013; Nilsson, Sundbom & Hagglof, 2008; Tyrka, Waldron, Graber & Brooks-Gunn, 2002), which fails to acknowledge the separate dimensions of socially prescribed and self-oriented perfectionism (Sherry, Hewitt, Besser, McGee & Flett, 2004). Other longitudinal studies have failed to control for baseline disordered eating levels (e.g. Soares et al., 2009). These methodological flaws make it difficult to draw comparisons with the present study. In order to better understand the relationship between socially prescribed perfectionism and disordered eating, future research examining perfectionism and EDs should use a multi-dimensional measure and ensure that baseline ED is controlled with a longitudinal design.

Strengths and Limitations.

A strength of the current study is the longitudinal design; previous research has generally favoured a cross-sectional design, which limits the capacity to infer causality or control for baseline levels of the dependent variable. Additionally, the large sample size at six-month follow-up provided ample statistical power to produce a meaningful result.

A number of limitations of this study need to be considered. Firstly, 85% of the sample scored above the clinical threshold in the EDEQ, indicating the presence of a clinical ED. Although this questionnaire alone should not be used to determine clinical ED classification, it is higher than anticipated for a community sample. These higher scores are likely to be due to a heightened interest in eating behaviours causing those with higher rates of disordered eating to be more willing to participate in

research on the subject area. Additionally, when inviting prospective participants to take part in the study on social media, prominent eating disorder bloggers and influencers occasionally shared the invitation on their own page. This is likely to have attracted an audience who experience higher levels of disordered eating, and thus may have biased this study's community sample. The high proportion of the sample scoring above the clinical threshold may make the results of this study more valid to a clinical eating disorders population, although a clinical sample determined by a psychological assessment would be needed to apply these findings to clinical populations with confidence. Furthermore, the perfectionistic self-presentation of one's body image has been found to play a moderating role in the relationship between shame and disordered eating, whereby the presence of perfectionistic self-presentation increases disordered eating behaviours (Marta-Simoes & Ferreira, 2016). Social media enables users to have more control over their self-presentation than face-to-face interactions (Ellison, Heino, & Gibbs, 2006), and perfectionistic individuals have been found to use social media more for self-presentation purposes (Al-Kandaria, Al-Sumaita & Al-Hunaiyyanb, 2017). Therefore, the recruitment through social media could have biased the sample towards those who use the platform for self-presentation, and thus are more likely to experience higher levels of disordered eating. As a result of the high scores on the EDEQ in the sample, the generalisability of the results of the present study to the normal population cannot be assumed.

Secondly, it is unclear whether the six-month window between T1 and T2 data gathering was sufficient to detect a meaningful change in scores across the measures. An insufficiently long break may explain the lack of significant change in disordered eating levels between T1 and T2. Consequently, these static scores may have restricted the present study's ability to identify the predictors of this limited variance.

Thirdly, 16.7% of the sample at T1 were from outside of the UK, whereas just 1.4% were from outside the UK at T2. Those from outside of the UK at T2 provided British phone numbers. Therefore, the process of texting participants to invite them to take part in T2 may have failed to contact those

without British phone numbers. Caution is advised when generalising these findings to samples outside the UK, and future research should consider methods to enable a multi-cultural sample.

Fourth, the internal consistency of the socially prescribed perfectionism subscale in the present study was questionable. The subscale was not adjusted in order to preserve validity, however the internal consistency highlights limitations of the subscale to reliably measure socially prescribed perfectionism within the sample and care should be taken when generalising these findings.

While the present study chose to investigate perfectionism as a mediator based on Hamacheck's model (1978), it could be argued that shame could also act as a mediator, i.e., in which failing at one's perfectionistic standards leads to a feeling of shame, increasing the risk of developing disordered eating as a result of shame; the present study did not conduct this analysis as this was not the focal hypothesis, and so cannot provide clarity regarding this other causal sequence. Equally, it would be logical to expect that shame and perfectionism function as moderators for one another, i.e., a causal relationship between perfectionism and disordered eating only exists when shame is present, or shame may only predict disordered eating in the presence of perfectionistic traits. Future studies might wish to explore these other associations in more detail.

Conclusions.

Internal and external shame, and self-oriented and socially prescribed perfectionism are positively correlated with disordered eating symptomatology. Socially prescribed perfectionism has a small positive predictive effect on disordered eating, indicating that perceived pressure from others to conform to a socially desirable body image may be a driving factor for disordered eating. The failure to find a predictive relationship between shame and disordered eating may indicate the need to examine shame constructs more specific to the body (i.e. body shame). No evidence was found to indicate that perfectionism mediates the relationship between shame and EDs.

References

- Al-Kandaria, A.A., Al-Sumaita, F.Y., Al-Hunaiyyanb, A. (2017) Looking perfect: Instagram use in a Kuwaiti cultural context. *Journal of International and Intercultural Communication*, DOI: 10.1080/17513057.2017.1281430
- Bardone-Cone, A.M., Abramson, L.Y., Vohs, K.D., Heatherton, T.F., Joiner, T.E. (2006) Predicting bulimic symptoms: An interactive model of self-efficacy, perfectionism, and perceived weight status. *Behavior, Research and Therapy*, 44, 27-42. <https://doi.org/10.1016/j.brat.2004.09.009>
- Bardone-Cone, A.M., Wonderlich, S.A., Frost, R.O., Bulik, C.M., Mitchell, J.E., Uppala, S., Simonich, H. (2007) Perfectionism and eating disorders: Current status and future directions. *Clinical Psychology Review*, 27, 384-405. DOI: 10.1016/j.cpr.2006.12.005
- Barrett, K.C. (1995) 'A functionalist approach to shame and guilt' in Tangney, J.P & Fischer, K.W. (eds) *Self-Conscious Emotions: The Psychology of Shame, Guilt, Embarrassment, and Pride*. New York, The Guildford Press, p25-63.
- Cohen, J. (1988) *Statistical power analysis for the behavioural sciences (2nd edition)*. Hillsdale, NJ: Erlbaum.
- Deci, E., Ryan, R. (eds) (2002) *Handbook of Self-Determination Research*. Rochester, NY: University of Rochester Press.
- Ellison, N., Heino, R., & Gibbs, J. (2006). Managing impressions online: Self-presentation processes in the online dating environment. *Journal of Computer-Mediated Communication*, 11, 415–441.
- Faija, C. L., Tierney, S., Gooding, P. A., Peters, S., Fox, J. R. E. (2017). The role of pride in women with anorexia nervosa: A grounded theory study. *Psychology and Psychotherapy: Theory, Research and Practice*, 90, 567-585. <https://doi.org/10.1111/papt.12125>
- Fairburn, C.G. (2008) *Cognitive behavior therapy and eating disorders*. New York: Guilford Press.

Fairburn, C.G, Beglin, S.J. (1994) Assessment of Eating Disorders: Interview or Self-Report Questionnaire? *International Journal of Eating Disorders*, 16, 363-370. <https://doi.org/10.1002/1098-108X>

Fairburn, C.,G Cooper, Z., Shafran, R. (2003) Cognitive behaviour therapy for eating disorders: a “transdiagnostic” theory and treatment. *Behaviour Research and Therapy*, 41, 509-528. DOI: 10.1016/S0005-7967(02)00088-8

Faul, F., Erdfelder, E., Buchner, A., Lang, A.G. (2009). Statistical power analyses using G*Power 3.1: Tests for correlation and regression analyses. *Behavior Research Methods*, 41, 1149-1160. doi:10.3758/BRM.41.4.1149

Frost, R.O., Marten, P., Rosenblate, R. (1990) The dimensions of perfectionism. *Cognitive Therapy Research*, 14, 449-468. DOI: 10.1007/BF01172967

Gale, C., Gilbert, P., Read, N., Goss, K. (2014) An evaluation of the impact of introducing compassion focused therapy to a standard treatment programme for people with eating disorders. *Clinical Psychology and Psychotherapy*, 21, 1-12. doi: 10.1002/cpp.1806.

Garner, D. M., Olmstead, M. P., & Polivy, J. (1983). Development and validation of a multidimensional eating inventory for anorexia nervosa and bulimia. *International Journal of Eating Disorders*, 2, 15-34. [https://doi.org/10.1002/1098-108X\(198321\)2:2<15::AID-EAT2260020203>3.0.CO;2-6](https://doi.org/10.1002/1098-108X(198321)2:2<15::AID-EAT2260020203>3.0.CO;2-6)

Gendall, K.A., Bulik, C.M., Sullivan, P.F., Joyce, P.R., McIntosh, V.V., Carter, F.A. (1999) Body weight in bulimia nervosa. *Eating and Weight Disorders - Studies on Anorexia, Bulimia and Obesity*, 4, 157-164. <https://doi.org/10.1007/BF03339730>

Gilbert, P. (1997) The evolution of social attractiveness and its role in shame, humiliation, guilt and therapy. *Psychology and Psychotherapy*, 70, 113-147. <https://doi.org/10.1111/j.2044-8341.1997.tb01893.x>

Gilbert, P. (1998) 'What is shame? Some core issues and controversies' in Gilbert, P. & Andrews, B. (eds) *Shame: Interpersonal Behaviour, Psychopathology and Culture*. New York, Oxford University Press, p3-38.

Gilbert, P. (2002). 'Body shame: a biopsychosocial conceptualization and overview with treatment implications' In P. Gilbert & J. Miles (Eds), *Body shame: Conceptualization, research & treatment*. Hove, UK: Brunner-Routledge, p3-54.

Goldner, E.M., Cockell, S.J., Srikameswaran, S. (2002) Perfectionism and Eating Disorders. In Flett, G.L & Hewitt, P.L (Eds.), *Perfectionism: Theory research and treatment*. Washington, DC: American Psychological Association, p319-340

Goss, K., Gilbert, P. (2002) 'Eating disorders, shame and pride' in Gilbert, P & Miles J. (eds) *Body Shame: Conceptualisation, Research and Treatment*. East Sussex, Brunner-Routledge, p219-255.

Goss, K., Gilbert, P. & Allan, S. (1994) An exploration of shame measures—I: The 'Other As Shamer' scale. *Personality and Individual Differences*, 17, 713-717. [https://doi.org/10.1016/0191-8869\(94\)90149-X](https://doi.org/10.1016/0191-8869(94)90149-X)

Hamachek, D. E. (1978). Psychodynamics of normal and neurotic perfectionism. *Psychology: A Journal of Human Behavior*, 15, 27-33.

Harder, D.W., Rockart, L., Cutler, L. (1993) Additional validity evidence for the Harder Personal Feelings Questionnaire-2 (PFQ2): A measure of shame and guilt proneness. *Journal of Clinical Psychology*, 49, 345-348. <https://doi.org/10.1002/1097-4679>

Harder, D. W., Zalma, A. (1990). Two promising shame and guilt scales: A construct validity comparison. *Journal of Personality Assessment*, 55, 729-745. DOI: 10.1080/00223891.1990.9674108

Hewitt, E L., & Flett, G. L. (1990). Perfectionism and depression: A multidimensional analysis. *Journal of Social Behavior and Personality*, 5, 423-438.

Hewitt, E L., & Flett, G. L. (1991). Perfectionism in the self and social contexts: Conceptualization, assessment, and association with psychopathology. *Journal of Personality and Social Psychology*, *60*, 456-470. <http://dx.doi.org/10.1037/0022-3514.60.3.456>

Holland, L.A., Bodell, L.P., Keel, P.K. (2013) Psychological factors predict eating disorder onset and maintenance at 10-year follow-up. *European Eating Disorders Review*, *21*, 405-410. DOI: 10.1002/erv.2241

Jose, P. E. (2013). *Doing statistical mediation and moderation*. New York, NY: Guilford Press.

Kelly, A.C., Carter, J.C. (2013) Why self-critical patients present with more severe eating disorder pathology: The mediating role of shame. *British Journal of Clinical Psychology*, *52*, 148-161. <https://doi.org/10.1111/bjc.12006>

Kelly, A.C., Tasca, G.A. (2016) Within-persons predictors of change during eating disorders treatment: An examination of self-compassion, self-criticism, and eating disorder symptoms. *International Journal of Eating Disorders*, *49*, 716-722. doi: 10.1002/eat.22527

Marta-Simoes, J., Ferreira, C. (2016) Seeking a perfect body look: feeding the pathogenic impact of shame? *Eating and Weight Disorders*, *21*, 477-485. doi: 10.1007/s40519-015-0240-x.

Mond, J.M., Hay, P.J., Rodgers, B., Owen, C. (2006) Eating Disorder Examination Questionnaire (EDE-Q): Norms for young adult women. *Behaviour Research and Therapy*, *44*, 53-62. DOI: 10.1016/j.brat.2004.12.003

Mond, J. M., Hay, P. J., Rodgers, B., Owen, C., & Beumont, P. V. (2004). Validity of the eating disorder examination questionnaire (EDE-Q) in screening for eating disorders in community samples. *Behaviour Research and Therapy*, *42*, 551–567. [https://doi.org/10.1016/S0005-7967\(03\)00161-X](https://doi.org/10.1016/S0005-7967(03)00161-X)

NHS Digital. (2017). *Health Survey for England, 2016*. [online] Available at: <https://digital.nhs.uk/data-and-information/publications/statistical/health-survey-for-england/health-survey-for-england-2016> [Accessed May 2019].

Nilsson, K., Sundbom, E., Hagglof, B. (2007) A longitudinal study of perfectionism in adolescent onset anorexia nervosa- restricting type. *European Eating Disorders Review*, 16, 386-394. <https://doi.org/10.1002/erv.850>

Nunnally, J. C. (1978) *Psychometric Theory, 2nd ed.*, New York: McGraw-Hill.

Sherry, S.B., Hewitt, P.L., Besser, A., McGee, B.J., Flett, G.L. (2004) Self-oriented and socially prescribed perfectionism in the Eating Disorder Inventory Perfectionism subscale. *International Journal of Eating Disorders*, 35, 69-79. DOI: 10.1002/eat.10237

Soares, M.J., Macedo, A., Bos, S.C., Marques, M., Maia, B., Pereira, A.T., Gomes, A., Valente, J., Pato, M., Azevedo, M.H. (2009) Perfectionism and eating attitudes in Portuguese students: a longitudinal study. *European Eating Disorders Review*, 17, 390-398. DOI: 10.1002/erv.926

Thompson, J. K., Heinberg, L., Altabe, M., & Tantleff-Dunn, S. (1999). *Exacting Beauty: Theory, assessment, and treatment of body image disturbance. Washington, DC: American Psychological Association.* <http://dx.doi.org/10.1037/10312-000>

Troop, N.A., Allan, S., Serpell, L., Treasure, J.L. (2008) Shame in women with a history of eating disorders. *European Eating Disorders Review*, 16, 480-488. doi: 10.1002/erv.858.

Troop, N.A., Redshaw, C. (2012) General shame and bodily shame in eating disorders: A 2.5 year longitudinal study. *European Eating Disorders Review*, 20, 373-378. DOI: 10.1002/erv.2160

Tyrka, A.R., Waldron, I., Graber, J.A., Brooks-Gunn, J. (2002) Prospective predictors of the onset of anorexic and bulimic syndromes. *International Journal of Eating Disorders*, 32, 282-290. DOI:10.1002/eat.10094

Welsh Government (2019). *National Survey for Wales.* [online] Available at: <https://gov.wales/national-survey-wales-results-viewer> [Accessed May 2019]

World Health Organization (1995) *Physical Status: The Use and Interpretation of Anthropometry: Report of a World Health Organization (WHO) Expert Committee*. Geneva, Switzerland: World Health Organization.

Paper 3 has been prepared in accordance with American Psychological Association author guidelines.

Paper 3: A Reflective Paper Providing a Critical Appraisal of the Systematic Review and Empirical Study

MacCormac, E,S.¹

¹South Wales Doctoral Programme in Clinical Psychology, Cardiff University, Cardiff, CF10 3AT

Word count (excluding tables/figures): 4,963

Paper 1: Systematic Review

Rationale for Topic of Study.

When considering my systematic review topic, I was initially drawn to the areas I aimed to examine in my empirical study. I hoped to conduct a systematic review that would complement both my empirical research and the evidence base on the topic.

As my empirical research examined the relationship between shame disordered eating, I conducted initial scoping searches using Google Scholar and PsycINFO to gauge the type and breadth of the existing literature examining the relationship between shame and disordered eating. However, when I updated my research supervisors on my progress, I was informed that another review matching this topic had just been accepted for publication, and one of my supervisors was an author. Therefore, I adjusted my scoping search to literature examining the relationship between shame and body mass index (BMI). I found a large amount of research into this relationship, which would have made the review beyond the scope of my project. However, during this process, I noticed that a large proportion of the studies focused solely on female samples, and although this female evidence base was also beyond the scope of my systematic review, it led me to examine the literature examining the relationship in male samples.

It became apparent that the relationship between shame and BMI in men appeared disproportionately under researched in comparison to women, and although there were several papers examining the relationship, they had not been reviewed. As a brief review of the results of these papers indicated that there may be a difference between men and women in their relationship between shame and BMI (e.g. Mason & Lewis 2015), I considered that reviewing the literature in male samples would be valuable to the evidence base.

Inclusion and Exclusion Criteria.

This review included peer-reviewed quantitative research papers available in English that directly examined BMI and shame in a male sample.

Having met with my supervisors and the subject librarian, I decided to only include studies that had been peer-reviewed and published to attempt to collect higher quality studies (Ware, 2008). The consequence of this decision is the vulnerability to publication bias, whereby studies that find significant effects are more likely to be published (Dwan et al., 2008). I decided to include only English-language studies in the review because the translation to English was considered beyond the scope of this review.

I excluded papers if they experimentally manipulated either shame or BMI or focused on evaluating treatments. This was to ensure the review focus remained on any naturally occurring relationship between shame and BMI in men. One experimental study was included because it did not experimentally manipulate either BMI or shame, and the analysis of these two variables was done at baseline. Therefore, I considered this relationship to be naturally occurring and not influenced by experimental manipulation.

I did not specify a date range in my inclusion criteria because doing so could limit the number of studies I found. Leit Pope and Gray (2001) found that the male body ideal has changed from being lean to become more muscular over time. Therefore, before the male body ideal became more muscular, it could be argued that it more closely matched the female body ideal (thin), and thus the relationship between BMI and shame in men may have more closely reflected the relationship in women. I reflected that examining studies from different time points could lead to conflicting results in the literature for this reason and could impact the results of the review. However, Leit et al (2001) examined evidence between 1973 and 1997, and all included studies were published well after this date, so the changes described are unlikely to have impacted the review.

Literature Search.

The databases chosen to search were Web of Science, PubMed, PsycInfo and Embase. I chose to examine all four databases to enable a thorough and complete examination of the available evidence base. These were chosen because they contain journals that focus on both medical and psychological topics and were likely to hold research studies relevant to this topic. I considered using MedLine, however, I was advised by the subject librarian that there is significant overlap between MedLine and PubMed. Due to the more comprehensive collection of studies in PubMed, I decided that omitting MedLine from my list of databases would be unlikely to damage the comprehensiveness of my search. Despite this consideration, all 46 results from the search of my final database, PubMed, were duplicate studies I had already found whilst searching the other databases. I also examined the reference lists of pertinent papers to ensure no relevant studies were omitted; however, I found no additional papers through this method.

After I screened results for title and abstract, I checked these papers against my inclusion and exclusion criteria. I gave a random selection of 50% of these papers to a second reviewer to check against the inclusion and exclusion criteria and we resolved any discrepancies through discussion. This was done to minimise risk of bias in the screening process (Moher et al., 2015).

I developed my key search terms based on the area of focus and considered any alternative words that may also encompass these concepts. I used 'wildcards' to search for various truncations of a word (such as 'eating disorder*') to ensure all variants (such as 'eating disorders' or 'eating disordered') would be captured. I initially included the word 'sham*' to encompass 'shame', 'shamed', 'shaming' and 'shameful'. However, this term produced thousands of papers discussing sham transcranial magnetic stimulation (TMS), so the search term was changed to 'shame' under the assumption that if a study directly measured shame, they would use this exact form of the word. After devising a draft list of key search terms, Charrois (2015) recommends meeting with the subject librarian to refine and clarify the search terms, search strategy and choice of databases. This process

helped me choose how to combine my search terms using Boolean operators. To ensure my literature search was as comprehensive as possible, I also confirmed my choice of search terms, search strategy and databases with my supervisors, as they have significant experience in the area.

A strength of this literature search was the logical and replicable process used, following the Preferred Reporting Items for Systematic Reviews and Meta-Analyses principles (Moher, Liberati, Tetzlaff & Altman, 2009). However, a limitation is that I completed both the initial scoping search and initial sift of the main literature search independently. Although a second reviewer checked 50% of the papers from the results of the initial sift against my inclusion and exclusion criteria, Da Costa and Juni (2014) advise having another reviewer screen the search results in duplicate. My independent initial sift may have been biased and conducting this in duplicate in future reviews would improve the rigour, minimise bias and human error.

Quality Assessment.

Sanderson, Tatt and Higgins (2007) highlight the importance of distinguishing between the quality of reporting and the susceptibility to bias through methodological limitations. Recommendations to guide the choice of quality assessment tool advise that the tool should have a small number of domains, be specific regarding study design, be a checklist not a scale, and show evidence of good reliability and validity (Sanderson, Tatt & Higgins, 2007). I used these recommendations to find the JBI Critical Appraisal Checklist for Analytical Cross-Sectional Studies (Munn, Moola, Riitano & Lisy, 2014), which I piloted with two of my included studies, but I decided that was not appropriate fit for the studies I had collected. I then considered the Appraisal tool for Cross-Sectional Studies (AXIS; Downes, Brennan, Williams & Dean, 2016), which fitted the recommended guidelines and suited the studies included in this review.

Under the advice of my supervisors, I reviewed the methodological and reporting quality of my studies using this tool in parallel with another reviewer. Any discrepancies were resolved through discussion to minimise bias in this process.

Although the AXIS enabled me to consider a variety of areas of the studies to examine their quality, it did not provide a classification system as a shorthand to describe the quality of each study. Having been the second reviewer for another literature review, I had experience of using the AMSTAR (Shea et al., 2017) and chose to develop a classification system based on this tool and apply it to the AXIS. I chose items I considered critical to the valid and reliable methodological and reporting quality and sought feedback from my supervisors. We agreed that I add one item (Item 10; 'Is it clear what was used to determine statistical significance and/or precision estimates?'). I was surprised to find how low in quality most of my studies were, and it helped me realise the importance of this quality assessment process. This experience has changed how I read papers; I focus more on the criteria that indicate good validity and reliability before making any assumptions. The use of this validated tool, and its focus on both reporting and methodological quality is a strength of this review.

I chose not to exclude papers purely based on the quality assessment because of the high number of studies that were 'critically low' in quality. If these studies were excluded there would be a limited number of studies remaining, which would significantly limit the scope of the review. Instead, I discussed the weaknesses in the studies when describing their findings and gave additional weight to higher quality studies.

Decision to Undertake a Systematic Review.

A systematic review method was chosen instead of a meta-analysis after considering the quality of the studies. Although a meta-analysis can increase the power of a review by combining the data, it would not have been reliable with the included studies due to the high proportion of studies that were

critically low in quality. Instead, a narrative review of each of the studies with reference to their quality was a more effective and reliable method of reviewing the literature.

Data Extraction.

I developed a data extraction spreadsheet to use for each of my studies to provide consistency and clarity and reduce bias (Higgins & Deeks, 2008). I did not have a second researcher to independently extract data from the studies, which may lead to more errors (Buscemi et al., 2006), however as I could not identify a researcher willing to perform this task, it was not possible for this review.

Implications.

This review identifies fundamental issues in the quality of the evidence base. For example, a large proportion of the studies adjusted measures without validating or piloting the changes. Often these changes involved translating the measures into different languages. This identifies a need for research to examine the psychometric properties of measures in different languages to make them accessible to researchers from non-English speaking countries.

Despite the significant limitations in quality within the evidence base, this review identified evidence that suggests there is a link between BMI and shame in males and that the relationship appears weaker than in females. This suggests that the relationship may not be as linear as in females and supports the notion that there may be other dominant factors involved in shame in men, such as the desire for muscularity. The ideal male body's transition to become more muscular over the years (Leit, Pope & Gray, 2001) means that men are likely to experience an increased drive for muscularity. If they do not consider themselves muscular enough, they are likely to experience shame. Therefore, future research implications that have arisen from this review include the examination of male shame

based on muscularity. The evidence base would also benefit from research examining the theory that shame is related to the extent of discrepancy between the actual body and ideal body size (Higgins, 1987).

It is difficult to draw any firm clinical conclusions from the review due to the poor quality of the studies. Until further high-quality research into the area is completed, clinicians should remain vigilant to the impact body size and image can have on shame in men.

Limitations of the Systematic Review.

The difficulties in the methodological and reporting quality of included studies have been identified. This limited the capacity to make any firm conclusions based on these studies and is considered a limitation of the review.

This review only examined the evidence base of studies published in English, which indicates a language bias. By excluding non-English studies, I may have missed out on high quality studies in this area that would have substantially improved my ability to draw conclusions. However, I was unable to identify a way to minimise this bias that was within the scope of the review. Research has found that publication bias is more pronounced when the studies are from non-English speaking countries and are published in English language journals (Egger et al., 1997). Therefore, this review may have had increased likelihood of being affected by publication bias. I considered ways to overcome this bias, such as examining unpublished studies, however the time required to find these studies would have been beyond the scope of the review.

Stevinson and Lawlor (2004) advise using multiple databases for a comprehensive examination of the existing evidence base. This review examined four databases; however, it could be argued that this review was limited by not searching through more databases. I decided to limit my search to four

based on previous published systematic reviews (e.g. Blythin et al., 2018) and the scope of this review. I found no new studies in my final database (but 46 duplications), which I considered a sign that I was not missing a substantial amount of the evidence base.

Reflections on the Systematic Review Process.

I found that conducting the systematic review increased my competence and confidence in synthesising and summarising a range of information. Having never completed a systematic review before, I initially found it quite daunting, but by examining guidance, I learnt to complete it in logical steps. Following this guidance helped me to use a methodical approach in this process and ensured that no steps were omitted. Consequently, I have developed my skills in developing and using a clear search strategy and applying inclusion and exclusion criteria that enable me to select the most appropriate studies. If I conduct another systematic review, I would ensure I have another reviewer to complete the initial sift of the papers in parallel. This would also increase my confidence that I had not missed any pertinent papers.

Although I understand that many studies have substantial weaknesses, I did not anticipate these to be inherent in almost all the evidence base I was examining. The quality assessment process was helpful to reflect on the critical areas that make a study reliable and valid. Keeping these in mind will help me when conducting and reviewing future research.

Paper 2: Empirical Study

Rationale for Topic of Study

As a Trainee, I have worked clinically with clients who experience shame, which appears to inhibit their help-seeking behaviour and self-compassion. Reflecting on this ignited my interest in shame and

how it relates to mental health difficulties. Therefore, when an opportunity to conduct research examining shame and its relationship to perfectionism and eating disorders arose, I was highly motivated to take it.

I discussed the project with my supervisors and read books and journals in the subject area to understand what the current evidence base indicated with regards to shame and perfectionism in disordered eating. I decided with my supervisors to quantitatively investigate whether shame and perfectionism independently predict eating disorders (EDs), and whether perfectionism acts as a mediator within the relationship between shame and EDs.

Initially I was unsure whether to examine whether shame or perfectionism was a mediator. When the individual perceives that they have failed to attain often inherently unobtainable perfectionistic standards, they experience shame and adopt disordered eating behaviour to manage the shame. Understanding this theory gave me the rationale that perfectionism was theoretically more likely to act as a mediating variable between shame and disordered eating.

Methodology.

Longitudinal designs offer advantages in analysis, whereby they can provide indication of the causality between variables, as opposed to cross-sectional studies that can only show an association between them (Lynn, 2009). As this feature was important for me to examine my hypotheses, I chose a longitudinal design. A six-month break between timepoint 1 (T1) and timepoint 2 (T2) was the longest I could afford, given the time constraints of this study.

Recruitment.

I chose to use a community sample for this research because of the additional variance afforded by a heterogeneous sample. By recruiting from the general population, I could recruit a larger sample, which enabled me to examine any effects statistically with adequate power. As much research into disordered eating has been done with non-clinical samples, my supervisors and I agreed that this non-clinical research would meaningfully contribute to the evidence base. Another factor in making this decision was that one of my colleagues was researching the same area using Grounded Theory methodology with a clinical population. My supervisors and I agreed that this research and my non-clinical research project would complement each other and collectively add a deeper understanding to the theory and evidence base of shame and perfectionism in disordered eating.

My supervisors told me that they had set up a Twitter account for a previous research study and it had hundreds of followers. They found this a helpful way to update participants on the progress of a study and I thought it would be helpful to encourage T1 participants to complete T2 using the same strategy.

My original recruitment plan was to use the Cardiff University Electronic Management System (EMS) to recruit Psychology students to participate in return for course credit. However, we began recruitment during the university summer break, which meant that no students were using EMS. This could not be adjusted due to the time constraints of the current study. The Twitter account had received several direct messages from people requesting to take part in the study, which led me to consider recruitment via social media. I thought that this would enable our study to recruit a heterogeneous sample of participants from different countries and backgrounds, without being constrained to a student sample, which may not be representative of the general population (Hanel & Vione, 2016).

After performing a power analysis, I found I would need 77 participants to achieve adequate statistical power at T2. Several papers reported very large attrition rates in longitudinal studies, so I decided to

aim to recruit as many as possible within the recruitment window I had to protect against attrition at T2. I consulted the literature for strategies to limit the attrition between T1 and T2 and as a result chose to offer a cash prize lottery at T1 and T2 (Pedersen & Nielsen, 2016) and utilise varying methods of communication (text, Twitter and Facebook) to capture the attention of participants (Vincent et al., 2012).

I was aware that I needed to recruit a large sample in a limited amount of time, so after receiving ethical approval I posted an invitation to take part in the questionnaire in approximately 70 groups on Facebook, and in tweets on the study Twitter page. I chose a range of groups on Facebook; some related to food/eating (e.g., 'Things full of beans that shouldn't be full of beans'), and many were unrelated (e.g., 'Tea and kittens', and 'Boxing: By Boxers'). I was impressed with the huge response of prospective participants clicking on the study and had several people asking if they could share the study invitation with family or friends and messaging me directly to ask more about it. I found this method of recruitment extremely effective, and although many of those who clicked the study did not complete it, I was still able to gather a sample large enough to provide good statistical power.

A limitation with regards to the high statistical power of the study involves the greater likelihood that small statistical effects would be detected. Indeed, the effect size of the predictive relationship between socially prescribed perfectionism and disordered eating was very small ($R^2=.01$). While this result was statistically significant, it is likely to be clinically less meaningful than a larger effect size. Having reflected on this, I ensured that I drew appropriate conclusions based on this small effect size.

The recruitment strategy was successful, however there were some limitations with it. First, it was not possible to capture any information about those who chose not to participate after seeing the invitation, which makes it impossible to draw conclusions about any differences between these individuals and the participants. Although the sample size was large enough, the proportion of participants who completed the research was a very small percentage of the number of individuals who are likely to have seen the study invitations. This is a limitation of this method of recruitment.

A second limitation of this method of recruitment is that it limits the sample to those who use social media and computers/smart phones. Research has found that social media usage is lower in older age groups (Office for National Statistics, 2017) and as a result the sample may have been biased. This review's final sample ranged from 18 to 70, which suggests that older adults were not fully excluded due to the recruitment strategy. However, as the mean age was 35, which indicates that there were disproportionately more younger adults who participated, I would consider additional methods of recruitment that would enable more older adults to engage in the research in future.

Measures.

The measure selected to examine perfectionism was the Multidimensional Perfectionism Scale (Hewitt & Flett, 1990). I chose this measure because I understood from the existing evidence the importance of examining perfectionism as a multidimensional construct (Sherry, Hewitt, Besser McGee & Flett, 2004). I chose Hewitt MPS over the Frost MPS (Frost, Marten, Lahart & Rosenblate, 1990) because Hewitt's subscales could be more closely linked to internal (self-oriented subscale) and external shame (socially prescribed subscale). Although the MPS (Hewitt & Flett, 1990) used has previously been found to have good psychometric properties (Hewitt & Flett, 1991), in this study the internal consistency of both subscales used was lower than expected. I considered attempting to increase the internal consistency, however on reflection with my supervisors, I decided that the changes and subsequent validation that would be involved in this process was beyond the scope of the study. The reason for the lower internal consistency is unclear, and future research is warranted to check the psychometric properties in different samples that may more closely represent the sample in this study.

To examine shame, I considered using the Body Shame Scale (Duarte, Pinto-Gouveia, Ferreira & Batista, 2015) as researchers have found body shame to be more predictive of disordered eating

(Troop & Redshaw, 2012). However, I chose to use measures of general shame because it related more to the theoretical underpinnings of the study (shame-pride and shame-shame cycles; Goss & Gilbert, 2002). To examine internal shame, I initially considered the Internalized Shame Scale (ISS; Cook, 1988), however the cost of this measure was above my budget and it had items that appeared to relate to perfectionism (“I feel myself striving for perfection only to continually fall short; I could beat myself over the head ... when I make a mistake”). Instead, I chose the Personal Feelings Questionnaire (PFQ; Harder & Zalma, 1990) as it is less lengthy than the ISS and has been found to have good psychometric properties (Harder, Rockart & Cutler, 1993).

I chose to examine external shame due to the multidimensional nature of shame and to explore whether this would have a different relationship to disordered eating than internal shame. I chose the Other as Shamer Scale (Goss, Gilbert & Allan, 1994) because it was within the project budget and had 18 items, which would not increase the time taken to complete the study too dramatically, so would be unlikely to introduce significant fatigue effects.

Method of Analysis.

I chose to examine whether there were correlations between the independent and dependent variables as a preliminary analysis to better understand the relationships between the variables. I then decided to examine whether the independent variables predict the dependent variable in a multiple regression, as this was deemed the most appropriate way to test my hypotheses. I considered different ways to control for baseline disordered eating (the dependent variable) in the regression, such as creating an ED change score. However, having discussed my options with a statistician at a data clinic, I chose to include T1 disordered eating as an independent variable so I could examine any change in residual variance over and above that predicted by baseline disordered eating.

Initially I planned to use the Baron and Kenny (1986) mediation approach (as shown in Figure 1), which was recommended to me by my supervisors. I intended to use bootstrapping to reduce the effect of random sampling errors when examining whether there was a mediating effect of perfectionism on the relationship between shame and EDs. However, I realised that to use Baron and Kenny's approach I would need to decide whether to include T1 or T2 data for my mediating variable into the analysis. I discussed this with supervisors and the statistician at the data clinic, however, their opinions were uncertain and contradictory. I could not find adequate justification to use T1, T2 or a composite of both. If I had realised this issue at the start of the project, I would have included a third timepoint (T3), so I could examine whether T2 perfectionism mediates the relationship between T1 shame and T3 disordered eating. I reflected that as my knowledge and understanding of different statistical methodologies and their strengths and weaknesses in relation to my data increased, choosing an appropriate methodology became more difficult. Due to the issues regarding which data to include in the model, instead of using Baron and Kenny's model, I chose to use Jose's (2013) longitudinal model of mediation. I felt that this fitted my data and enabled the mediating variable's data at both T1 and T2 to be included in the analysis.

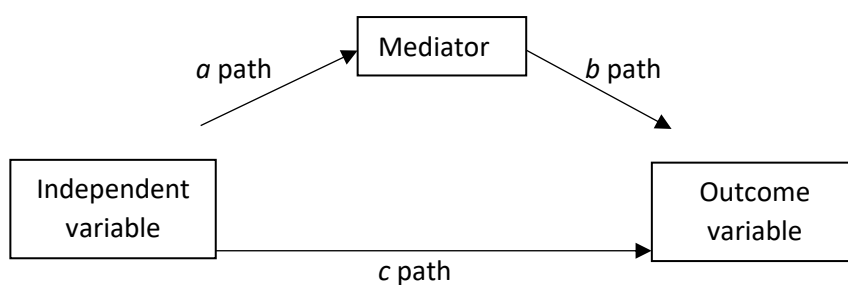

Figure 1: Baron and Kenny (1986) mediation model

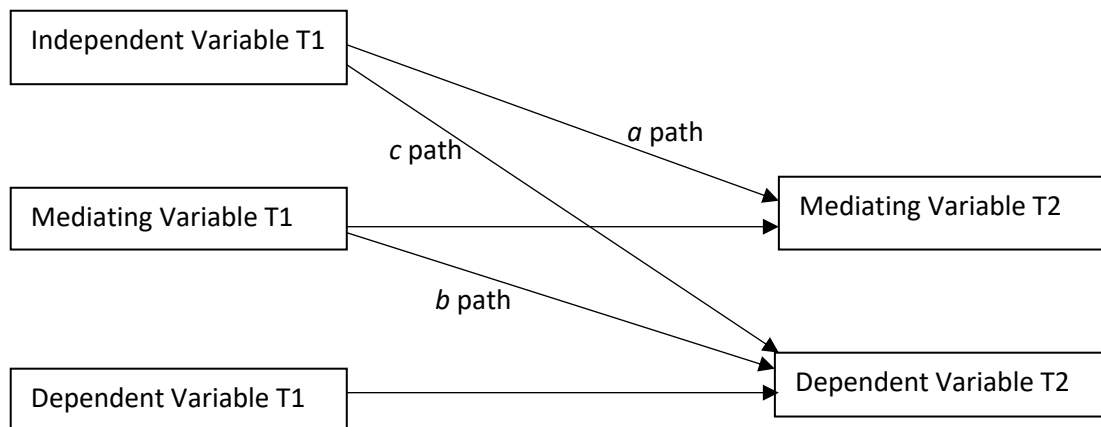

Figure 2: Two-wave longitudinal mediation model (Jose, 2013)

Implications of Research.

This study advanced the evidence base by examining the relationships of shame and perfectionism to disordered eating longitudinally, whilst controlling for baseline disordered eating. Previous research has often failed to use a multi-dimensional measure of perfectionism (e.g., Holland, Bodell & Keel, 2013) or not controlled for baseline levels of disordered eating (e.g. Soares et al., 2009), which is likely to have biased the findings. Therefore, the longitudinal design and controlling for baseline ED in this study are considered methodological strengths of the research. Future research should ensure a longitudinal design is used so baseline disordered eating can be controlled. Additionally, as Sherry et al. (2004) points out, a perfectionism measure should acknowledge the separate dimensions of socially prescribed and self-oriented perfectionism when examining the relationship between perfectionism and disordered eating in the future.

Goss & Gilbert (2002)'s shame-pride and shame-shame model proposes that internal and external shame are central to the development and maintenance of EDs. As a result, I expected shame to predict disordered eating in this study and was surprised when it did not. Although the present study

found that shame was correlated with disordered eating, the failure to find a predictive relationship between shame and disordered eating has theoretical implications as it does not support Goss and Gilbert's theory.

An alternative theory to explain the finding from previous research that body shame predicts EDs (Troop & Redshaw, 2012), and the current finding that internal and external shame do not, is the objectification theory (Fredrickson & Roberts, 1997). This theory postulates that as a result of widespread objectification, women develop a strategy of self-objectification by closely monitoring their own appearance, which helps them to anticipate and control how others see them. The process of scrutinising one's body in self-objectification is thought to lead to the experience of body shame, which, in turn, motivates dieting and binge-purge cycles (Fredrickson & Roberts, 1997). This theory proposes that the shame experienced is specific to the body and evidence for it has since also been found in male samples (Oehlhof, Musher-Eizenman, Neufield & Hauser, 2009). Therefore, the finding that internal and external shame did not predict ED may be more in line with the objectification theory, with the failure to predict disordered eating due to the measures' lack of specific focus on body shame.

Personal and Professional Reflections.

I have found the process of conducting this research rewarding and I believe that my clinical work has also benefitted. I have valued the opportunity to engage so fully with the existing evidence base in a clinically relevant area, as well as the opportunity to develop my research skills in adding to it. Understanding models of shame and disordered eating has enabled me to use these models as theoretical underpinning whilst formulating with a client on my clinical caseload who presents with disordered eating behaviours.

I have reflected on the high levels of disordered eating in my sample, and how this may indicate that disordered eating behaviours are more widespread than previously thought. In my clinical work, I have worked with several clients who do not have any formal eating disorder diagnoses and do not view their relationship with food/eating as a primary concern. However, they present with strong traits of disordered eating, which appear to be associated with their primary mental health difficulties. As shame has been associated with a variety of mental health difficulties (Kim, Thibodeau & Jorgensen, 2011), I reflected that focusing on the factors that cause shame and targeting shame in therapeutic interventions should be a primary goal.

Dissemination Strategy.

This research will be disseminated via journal publication. Papers 1 and 2 have been prepared for submission to the *Psychology and Psychotherapy* journal (impact factor: 2.097, ISI Journal Citation Reports © Ranking 2017: 56/127 [Psychology, Clinical]). I plan to prepare my results for presentation to experts in the field at the London Eating Disorders Conference 2020. I also intend to disseminate my research to psychologists working clinically with an adult population by presenting at the Aneurin Bevan Health Board specialty meeting.

References

Baron, R.M., Kenny, D.A. (1986) The moderator-mediator variable distinction in social psychological research: Conceptual, strategic, and statistical considerations. *Journal of Personality and Social Psychology*, 51, 1173-1182.

- Blythin, S.P.M., Nicholson, H.L., Macintyre, V.G., Dickson, J.M., Fox, J.R.E., Taylor, P.J. (2018) Experiences of shame and guilt in anorexia and bulimia nervosa: A systematic review. *Psychology and Psychotherapy*, DOI: 10.1111/papt.12198
- Buscemi, N., Hartling, L., Vandermeer, B., Tjosvold, L., Klassen, T. P. (2006). Single data extraction generated more errors than double data extraction in systematic reviews. *Journal of Clinical Epidemiology*, 59, 697-703. DOI: 10.1016/j.jclinepi.2005.11.010
- Charrois, T.L. (2015) Systematic reviews: What do you need to know to get started? *The Canadian Journal of Hospital Pharmacy*, 68, 144-148. DOI: <http://dx.doi.org/10.4212/cjhp.v68i2.1440>
- Cook D.R. (1988) Measuring shame: The Internalized Shame Scale. *Alcoholism Treatment Quarterly*, 4, 197–215. https://doi.org/10.1300/J020v04n02_12
- Da Costa, B.R., Juni, P. (2014) Systematic reviews and meta-analyses of randomized trials: Principles and pitfalls. *European Heart Journal*, 35, 3336-3345.
- Downes, M.J., Brennan, M.L., Williams, H.C., Dean, R.S (2016). Development of a critical appraisal tool to assess the quality of cross-sectional studies (AXIS). *BMJ Open*, 6, 1-7. doi:10.1136/bmjopen-2016-011458
- Duarte, C., Pinto-Gouveia, J., Ferreira, C., Batista, D. (2015) Body image as a source of shame: A new measure for the assessment of the multifaceted nature of body image shame. *Clinical Psychology and Psychotherapy*, 22, 656-666. DOI: 10.1002/cpp.1925
- Dwan, K., Altman, D. G., Arnaiz, J. A., Bloom, J., Chan, A.-W., Cronin, E., ...Williamson, P. R. (2008). Systematic review of the empirical evidence of study publication bias and outcome reporting bias. *PLoS ONE*, 3, 1-37. doi:10.1371/journal.pone.0003081

Egger, M., Zellweger-Zähner, T., Schneider, M., Junker, C., Lengeler, C., & Antes, G. (1997). Language bias in randomised controlled trials published in English and German. *The Lancet*, *350*, 326-329. DOI: 10.1016/S0140-6736(97)02419-7

Fredrickson, B. L., & Roberts, T. (1997). Objectification theory: Toward understanding women's lived experiences and mental health risks. *Psychology of Women Quarterly*, *21*, 173– 206. <https://doi.org/10.1111/j.1471-6402.1997.tb00108.x>

Frost, R.O., Marten, P., Lahart, C., & Rosenblate, R. (1990). The dimensions of perfectionism. *Cognitive Therapy and Research*, *14*, 449-468.

Goss, K., Gilbert, P. (2002) 'Eating disorders, shame and pride' in Gilbert, P & Miles J. (eds) *Body Shame: Conceptualisation, Research and Treatment*. East Sussex, Brunner-Routledge, p219-255.

Goss, K., Gilbert, P. & Allan, S. (1994) An exploration of shame measures—I: The 'Other As Shamer' scale. *Personality and Individual Differences*, *17*, 713-717. [https://doi.org/10.1016/0191-8869\(94\)90149-X](https://doi.org/10.1016/0191-8869(94)90149-X)

Hanel, P.H.P., Vione, K.C. (2016) Do student samples provide an accurate estimate of the general public? *PLoS One*, *11*, DOI: 10.1371/journal.pone.0168354

Harder, D.W., Rockart, L., Cutler, L. (1993) Additional validity evidence for the Harder Personal Feelings Questionnaire-2 (PFQ2): A measure of shame and guilt proneness. *Journal of Clinical Psychology*, *49*, 345-348. <https://doi.org/10.1002/1097-4679>

Harder, D. W., Zalma, A. (1990). Two promising shame and guilt scales: A construct validity comparison. *Journal of Personality Assessment*, *55*, 729-745. DOI: 10.1080/00223891.1990.9674108

Hewitt, E L., & Flett, G. L. (1990). Perfectionism and depression: A multidimensional analysis. *Journal of Social Behavior and Personality*, *5*, 423-438.

Hewitt, E L., & Flett, G. L. (1991). Perfectionism in the self and social contexts: Conceptualization, assessment, and association with psychopathology. *Journal of Personality and Social Psychology*, *60*, 456-470. <http://dx.doi.org/10.1037/0022-3514.60.3.456>

Higgins, E.T. (1987) Self-discrepancy: A theory relating self and affect. *Psychological Review*, *94*, 319-340. <http://dx.doi.org/10.1037/0033-295X.94.3.319>

Higgins, J.P.T., Deeks, J.J. (2008) Selecting studies and collecting data. In: Higgins JP and Green S (eds) *Cochrane handbook for systematic reviews of interventions*. Chichester: John Wiley & Sons Ltd. <https://doi.org/10.1002/9780470712184.ch7>

Holland, L.A., Bodell, L.P., Keel, P.K. (2013) Psychological factors predict eating disorder onset and maintenance at 10-year follow-up. *European Eating Disorders Review*, *21*, 405-410. DOI: 10.1002/erv.2241

Jose, P. E. (2013). *Doing statistical mediation and moderation*. New York, NY: Guilford Press.

Kim, S., Thibodeau, R., & Jorgensen, R. S. (2011). Shame, guilt, and depressive symptoms: A meta analytic review. *Psychological Bulletin*, *137*, 68– 96. <https://doi.org/10.1037/a0021466>

Leit, R.A., Pope, H.G., Gray, J.J. (2001) Cultural Expectations of Muscularity in Men: The Evolution of Playgirl Centerfolds. *International Journal of Eating Disorders*, *29*, 90-93. [https://doi.org/10.1002/1098-108X\(200101\)29:1<90::AID-EAT15>3.0.CO;2-F](https://doi.org/10.1002/1098-108X(200101)29:1<90::AID-EAT15>3.0.CO;2-F)

Lynn, P. (2009) *Methodology of Longitudinal Surveys*. John Wiley & Sons, Ltd

Mason, T.B., Lewis, R.J. (2015) Assessing the roles of impulsivity, food-related cognitions, BMI, and demographics in the dual pathway model of binge eating among men and women. *Eating Behaviours*, *18*, 151-155. <http://dx.doi.org/10.1016/j.eatbeh.2015.05.015>

Moher, D., Liberati, A., Tetzlaff, J., & Altman, D. (2009). Preferred reporting items for systematic reviews and meta-analysis: The PRISMA statement. *International Journal of Surgery*, *8*, 336-341. doi: 10.1136/bmj.b2535

Moher, D., Shamseer, L., Clarke, M., Ghersi, D., Liberati, A., Petticrew, M., Shekelle, P., Stewart, L.A. (2015) Preferred reporting items for systematic review and meta-analysis protocols (PRISMA-P) 2015 statement. *Systematic Reviews*, *4*, doi: 10.1186/2046-4053-4-1.

Munn, Z., Moola, S., Riitano, D., Lisy, K. (2014) The development of a critical appraisal tool for use in systematic reviews addressing questions of prevalence. *International Journal of Health Policy and Management*, *3*, 123-128. doi: 10.15171/ijhpm.2014.71

Oehlhof, M.E., Musher-Eizenman, D.R., Neufield, J.M., Hauser, J.C (2009) Self-objectification and ideal body shape for men and women. *Body Image*, *6*, 308-310. DOI: 10.1016/j.bodyim.2009.05.002

Office for National Statistics (2017) Social networking by age group, 2011 to 2017. Retrieved from <https://www.ons.gov.uk/peoplepopulationandcommunity/householdcharacteristics/homeinternetandsocialmediausage/adhocs/007401socialnetworkingbyagegroup2011to2017>

Pedersen, M.J., Nielsen, C.V. (2016) Improving survey response rates in online panels: Effects of low-cost incentives and cost-free text appeal interventions. *Social Science Computer Review*, *34*, 229-243. DOI: 10.1177/0894439314563916

Sanderson, S., Tatt, I.D., Higgins, J.P.T. (2007) Tools for assessing quality and susceptibility to bias in observational studies in epidemiology: A systematic review and annotated bibliography. *International Journal of Epidemiology*, *36*, 666-676. Doi: 10.1093/ije/dym018

Shea, B.J., Reeves, B.C., Wells, G., Thuku, M., Hamel, C., Moran, J., Moher, D., Tugwell, P Welch, V., Kristjansson, E., Henry, D.A. (2017) AMSTAR 2: a critical appraisal tool for systematic reviews that

include randomised or non-randomised studies of healthcare interventions, or both. *BMJ*, 358, 1-9.

doi: 10.1136/bmj.j4008

Sherry, S.B., Hewitt, P.L., Besser, A., McGee, B.J., Flett, G.L. (2004) Self-oriented and socially prescribed perfectionism in the Eating Disorder Inventory Perfectionism subscale. *International Journal of Eating Disorders*, 35, 69-79. DOI: 10.1002/eat.10237

Soares, M.J., Macedo, A., Bos, S.C., Marques, M., Maia, B., Pereira, A.T., Gomes, A., Valente, J., Pato, M., Azevedo, M.H. (2009) Perfectionism and eating attitudes in Portuguese students: a longitudinal study. *European Eating Disorders Review*, 17, 390-398. DOI: 10.1002/erv.926

Stevinson, C., Lawlor, D.A. (2004) Searching multiple databases for systematic reviews: Added value or diminishing returns? *Complementary Therapies in Medicine*, 12, 228-232. <https://doi.org/10.1016/j.ctim.2004.09.003>

Troop, N.A., Redshaw, C. (2012) General shame and bodily shame in eating disorders: A 2.5 year longitudinal study. *European Eating Disorders Review*, 20, 373-378. DOI: 10.1002/erv.2160

Vincent, K.B., Kasperski, S.J., Caldeira, K.M., Garnier-Dykstra, L.M., Pinchevsky, G.M., O'Grady, K.E., Arria, A.M. (2012) Maintaining superior follow-up rates in a longitudinal study: Experiences from the college life study. *International Journal of Multiple Research Approaches*, 6.

Ware, M. (2008) Peer review in scholarly journals: Perspectives of the scholarly community – Results from an international study. *Information Services & Use*, 28, 109-112. DOI 10.3233/ISU-2008-0568

Appendices

Appendix A: Psychology and Psychotherapy Journal Author Guidelines.

1. Submission.

Authors should kindly note that submission implies that the content has not been published or submitted for publication elsewhere except as a brief abstract in the proceedings of a scientific meeting or symposium.

Once the submission materials have been prepared in accordance with the Author Guidelines, manuscripts should be submitted online at <http://www.editorialmanager.com/paptrap>

Click here for more details on how to use **Editorial Manager**.

All papers published in the *Psychology and Psychotherapy: Theory Research and Practice* are eligible for Panel A: Psychology, Psychiatry and Neuroscience in the Research Excellence Framework (REF).

Data protection:

By submitting a manuscript to or reviewing for this publication, your name, email address, and affiliation, and other contact details the publication might require, will be used for the regular operations of the publication, including, when necessary, sharing with the publisher (Wiley) and partners for production and publication. The publication and the publisher recognize the importance of protecting the personal information collected from users in the operation of these services, and have practices in place to ensure that steps are taken to maintain the security, integrity, and privacy of the personal data collected and processed. You can learn more at <https://authorservices.wiley.com/statements/data-protection-policy.html>.

Preprint policy:

This journal will consider for review articles previously available as preprints on non-commercial servers such as ArXiv, bioRxiv, psyArXiv, SocArXiv, engrXiv, etc. Authors may also post the submitted version of a manuscript to non-commercial servers at any time. Authors are requested to update any pre-publication versions with a link to the final published article.

2. Aims and Scope.

Psychology and Psychotherapy: Theory Research and Practice is an international scientific journal with a focus on the psychological aspects of mental health difficulties and well-being; and psychological problems and their psychological treatments. We welcome submissions from mental health professionals and researchers from all relevant professional backgrounds. The Journal welcomes submissions of original high quality empirical research and rigorous theoretical papers of any theoretical provenance provided they have a bearing upon vulnerability to, adjustment to, assessment of, and recovery (assisted or otherwise) from psychological disorders. Submission of systematic reviews and other research reports which support evidence-based practice are also welcomed, as are relevant high quality analogue studies and Registered Reports. The Journal thus aims to promote theoretical and research developments in the understanding of cognitive and emotional factors in

psychological disorders, interpersonal attitudes, behaviour and relationships, and psychological therapies (including both process and outcome research) where mental health is concerned. Clinical or case studies will not normally be considered except where they illustrate particularly unusual forms of psychopathology or innovative forms of therapy and meet scientific criteria through appropriate use of single case experimental designs.

All papers published in *Psychology and Psychotherapy: Theory, Research and Practice* are eligible for Panel A: Psychology, Psychiatry and Neuroscience in the Research Excellence Framework (REF).

3. Manuscript Categories and Requirements.

- Articles should adhere to the stated word limit for the particular article type. The word limit excludes the abstract, reference list, tables and figures, but includes appendices.

Word limits for specific article types are as follows:

- Research articles: 5000 words
- Qualitative papers: 6000 words
- Review papers: 6000 words
- Special Issue papers: 5000 words

In exceptional cases the Editor retains discretion to publish papers beyond this length where the clear and concise expression of the scientific content requires greater length (e.g., explanation of a new theory or a substantially new method). Authors must contact the Editor prior to submission in such a case.

Please refer to the separate guidelines for **Registered Reports**.

All systematic reviews must be pre-registered.

4. Preparing the Submission.

Contributions must be typed in double spacing. All sheets must be numbered.

Cover Letters

Cover letters are not mandatory; however, they may be supplied at the author's discretion. They should be pasted into the 'Comments' box in Editorial Manager.

Parts of the Manuscript

The manuscript should be submitted in separate files: title page; main text file; figures/tables; supporting information.

Title Page

You may like to use **this template** for your title page. The title page should contain:

- A short informative title containing the major key words. The title should not contain abbreviations (see Wiley's **best practice SEO tips**);

- A short running title of less than 40 characters;
- The full names of the authors;
- The author's institutional affiliations where the work was conducted, with a footnote for the author's present address if different from where the work was conducted;
- Abstract;
- Keywords;
- Practitioner Points;
- Acknowledgments.

Authorship

Please refer to the journal's Authorship policy in the Editorial Policies and Ethical Considerations section for details on author listing eligibility. When entering the author names into Editorial Manager, the corresponding author will be asked to provide a CRediT contributor role to classify the role that each author played in creating the manuscript. Please see the [Project CRediT](#) website for a list of roles.

Abstract

Please provide an abstract of up to 250 words, giving a concise statement of the intention, results or conclusions of the article.

Articles containing original scientific research should include the headings: Objectives, Design, Methods, Results, Conclusions. Review articles should use the headings: Purpose, Methods, Results, Conclusions.

Keywords

Please provide appropriate keywords.

Practitioner Points

All articles must include Practitioner Points – these are 2-4 bullet points, following the abstract, with the heading 'Practitioner Points'. These should briefly and clearly outline the relevance of your research to professional practice. (Please include the 'Practitioner Points' in your main document but do not submit them to Editorial Manager with your abstract.)

Acknowledgments

Contributions from anyone who does not meet the criteria for authorship should be listed, with permission from the contributor, in an Acknowledgments section. Financial and material support should also be mentioned. Thanks to anonymous reviewers are not appropriate.

Main Text File

As papers are double-blind peer reviewed, the main text file should not include any information that might identify the authors.

The main text file should be presented in the following order:

- Title
- Main text
- References
- Tables and figures (each complete with title and footnotes)
- Appendices (if relevant)

Supporting information should be supplied as separate files. Tables and figures can be included at the end of the main document or attached as separate files but they must be mentioned in the text.

- As papers are double-blind peer reviewed, the main text file should not include any information that might identify the authors. Please do not mention the authors' names or affiliations and always refer to any previous work in the third person.
- The journal uses British/US spelling; however, authors may submit using either option, as spelling of accepted papers is converted during the production process.

References

References should be prepared according to the *Publication Manual of the American Psychological Association* (6th edition). This means in text citations should follow the author-date method whereby the author's last name and the year of publication for the source should appear in the text, for example, (Jones, 1998). The complete reference list should appear alphabetically by name at the end of the paper. Please note that for journal articles, issue numbers are not included unless each issue in the volume begins with page 1, and a DOI should be provided for all references where available.

For more information about APA referencing style, please refer to the [APA FAQ](#).

Reference examples follow:

Journal article

Beers, S. R. , & De Bellis, M. D. (2002). Neuropsychological function in children with maltreatment-related posttraumatic stress disorder. *The American Journal of Psychiatry*, *159*, 483–486. doi:[10.1176/appi.ajp.159.3.483](https://doi.org/10.1176/appi.ajp.159.3.483)

Book

Bradley-Johnson, S. (1994). *Psychoeducational assessment of students who are visually impaired or blind: Infancy through high school* (2nd ed.). Austin, TX: Pro-ed.

Internet Document

Norton, R. (2006, November 4). How to train a cat to operate a light switch [Video file]. Retrieved from <http://www.youtube.com/watch?v=Vja83KLQXZs>

Tables

Tables should be self-contained and complement, not duplicate, information contained in the text. They should be supplied as editable files, not pasted as images. Legends should be concise but comprehensive – the table, legend, and footnotes must be understandable without reference to the

text. All abbreviations must be defined in footnotes. Footnote symbols: †, ‡, §, ¶, should be used (in that order) and *, **, *** should be reserved for P-values. Statistical measures such as SD or SEM should be identified in the headings.

Figures

Although authors are encouraged to send the highest-quality figures possible, for peer-review purposes, a wide variety of formats, sizes, and resolutions are accepted.

Click here for the basic figure requirements for figures submitted with manuscripts for initial peer review, as well as the more detailed post-acceptance figure requirements.

Legends should be concise but comprehensive – the figure and its legend must be understandable without reference to the text. Include definitions of any symbols used and define/explain all abbreviations and units of measurement.

Colour figures. Figures submitted in colour may be reproduced in colour online free of charge. Please note, however, that it is preferable that line figures (e.g. graphs and charts) are supplied in black and white so that they are legible if printed by a reader in black and white. If an author would prefer to have figures printed in colour in hard copies of the journal, a fee will be charged by the Publisher.

Supporting Information

Supporting information is information that is not essential to the article, but provides greater depth and background. It is hosted online and appears without editing or typesetting. It may include tables, figures, videos, datasets, etc.

Click here for Wiley's FAQs on supporting information.

Note: if data, scripts, or other artefacts used to generate the analyses presented in the paper are available via a publicly available data repository, authors should include a reference to the location of the material within their paper.

General Style Points

For guidelines on editorial style, please consult the **APA Publication Manual** published by the American Psychological Association. The following points provide general advice on formatting and style.

- **Language:** Authors must avoid the use of sexist or any other discriminatory language.
- **Abbreviations:** In general, terms should not be abbreviated unless they are used repeatedly and the abbreviation is helpful to the reader. Initially, use the word in full, followed by the abbreviation in parentheses. Thereafter use the abbreviation only.
- **Units of measurement:** Measurements should be given in SI or SI-derived units. Visit the **Bureau International des Poids et Mesures (BIPM) website** for more information about SI units.
- **Effect size:** In normal circumstances, effect size should be incorporated.

Appendix B: Quality Assessment Results of Included Studies.

Authors (date)	Aims/objectives clear	Appropriate study design	Sample size justified	Target population clearly defined	Sample frame taken from appropriate population base to represent target population	Selection process likely to select participants representative of target population	Measures taken to address and categorise non-responders	Appropriate risk factor and outcome variables measured	Risk factor and outcome variables measured correctly	Clear what was used to determine statistical significance	Methods sufficiently described for replicability	Basic data adequately described	Response rate raise concerns about non-response bias	Information about non-responders described	Results internally consistent	Results presented for all analyses described in methods	Conclusions justified by results	Limitations discussed	Conflicts of interest that may affect interpretation of results	Ethical approval or consent attained	Overall quality rating
Boisvert, J.A., Harrell, W.A. (2009)	Y	Y	N	Y	N	N	N	Y	Y	Y	N	Y	Y	N/a	N	Y	Y	Y	N	N	Critically low
Boisvert, J.A., Harrell, W.A. (2012)	Y	Y	N	Y	N	N	N	Y	N	Y	Y	Y	Y	N/a	Y	Y	Y	Y	N	Y	Critically low
Castonguay, A.L., Pila, E., Wrosch, C., Sabiston, C.M. (2015)	Y	Y	N	Y	Y	Y	N	Y	Y	Y	Y	Y	Y	N/a	Y	Y	N	Y	N	Y	High

Daniel, S., Bridges, S.K. (2010)	Y	Y	N	Y	N	N	N	Y	N	Y	Y	Y	Y	N/a	Y	Y	Y	Y	N	Y	Critically low
Dumitrescu, A.L., Manolescu, B.N. (2011)	N	Y	N	Y	N	N	N	N	N	Y	N	Y	Y	N/a	N	Y	N	Y	N	Y	Critically low
Himmelstein, M., Tomiyama, A.J. (2015)	Y	Y	N	N	N	DK*	N	Y	N	Y	Y	Y	Y	N/a	Y	Y	Y	Y	N	N	Critically low
Jambekar, S.A., Mashed, R.M., Grilo, C.M (2003)	Y	Y	N	Y	N	Y	N	Y	N	Y	Y	Y	Y	N/a	N	Y	Y	Y	N	N	Critically low
Knauss, C., Paxton, S.J., Alasker, F.D (2008)	Y	Y	N	Y	N	Y	Y	Y	N	Y	Y	Y	N	N	N	Y	Y	Y	N	Y	Low
Marta-Simoes, J., Ferreira, C., Mendes, A.L. (2016)	Y	Y	N	Y	N	N	N	Y	N	Y	Y	Y	Y	N/a	Y	Y	Y	Y	N	Y	Critically low
Martins, Y.,	Y	Y	N	Y	N	N	N	Y	N	Y	Y	Y	Y	N/a	Y	Y	Y	Y	N	N	Critically low

Tiggeman, M., Kirkbride, A. (2007); Study 1																					
Mason, T. B., Lewis, R.J (2015)	N	Y	N	Y	N	N	N	N	N	Y	N	N	Y	N/a	Y	N	Y	N	N	N	Critically low
Oliviera, S., Trindade, I., Ferreira, C. (2018)	Y	Y	N	Y	N	N	N	Y	Y	Y	Y	Y	Y	N/a	Y	Y	Y	Y	N	Y	Low
Rollero, C., Gattino, S., De Piccoli, N., Fedi, A. (2018)	Y	Y	N	Y	N	N	N	Y	N	Y	Y	Y	Y	N/a	Y	N	Y	Y	N	Y	Critically low
Tylka, T.L., Kroon, A.M. (2013); Study 2	Y	Y	N	Y	N	Y	N	Y	Y	Y	Y	Y	Y	N/a	Y	Y	Y	Y	N	Y	Moderate
Wiseman, M.C., Moradi, B. (2010)	Y	Y	N	Y	Y	Y	N	Y	N	Y	N	Y	Y	N	Y	Y	Y	Y	N	Y	Low

Note. *Unclear as target population not define

Appendix C: Ethics Committee Study Approval.



psychethics

Fri 16/02/2018, 15:22

Natalie Stott; Elinor MacCormac; John Fox

Inbox

Dear Natalie & Elinor,

The Ethics Committee has considered your revised project proposal: Does perfectionism continue to predict disordered eating when shame is controlled for? (EC.18.01.09.5206R).

The project has now been approved.

Please note that if any changes are made to the above project then you must notify the Ethics Committee.

Best wishes,
Mark Jones

School of Psychology Research Ethics Committee
Cardiff University
Tower Building
70 Park Place
Cardiff
CF10 3AT

Tel: +44(0)29 208 70360
Email: psychethics@cardiff.ac.uk
<http://psych.cf.ac.uk/aboutus/ethics.html>
Prifysgol Caerdydd
Adeilad y Tŵr
70 Plas y Parc

PARTICIPANT INFORMATION SHEET

Study 1: Metacognition in disordered eating

Study 2: The relationship between perfectionism and shame in disordered eating

Researchers: Natalie Stott & Elinor MacCormac

You are being invited to take part in a joint research project that is being undertaken as part of a Doctorate in Clinical Psychology. Please read the information below carefully before deciding whether to take part. If you have any questions, please contact the researcher.

Why is the study being done?

One study (Study 1) will look at the relationship between people's worries and the effect of these worries on their eating behaviour. The findings of the study will be used to further our understanding of how our worries can affect eating behaviour.

The other study (Study 2) will look at the relationship between traits of perfectionism and feelings of shame in the context of disordered eating. This will help inform the most effective form of therapy for disordered eating in the future.

Background Research

Study 1

Anxiety is understood to be a core and debilitating clinical feature present in those with eating disordered behaviour. However, cognitive processes underlying anxiety in eating disorders are poorly understood (Kesby et al., 2017). Research has suggested that worry and rumination is a key feature of those with eating disorders; Sternheim and colleagues (2012) found a positive correlation between level of worry and level of eating disorder symptoms. Research has also indicated that disordered eating behaviour is correlated to loneliness and greater social impairment (Spoor et al, 2007).

Metacognition is defined as 'knowledge about one's own thoughts' and the factors that influence one's thinking. Over the past decade, researchers have begun to investigate the role of metacognitions within the eating disorder population. Although research is extremely limited, metacognition has been significantly correlated with eating disorder symptomatology (Olstad, et al 2015) and findings have shown that cognitive processes play an important role in the maintenance of eating pathology (Rawal.,et al 2010). A metacognitive model was developed by Wells (2009) to show how individuals can get stuck in a cycle of worry and it also suggests that people develop thought controlling strategies to manage their worry.

The metacognitive model has been applied to many disorders including generalized anxiety disorder (Wells & King, 2006;; Wells et al., 2010) and posttraumatic stress disorder (Wells & Colbear, 2012;; Wells et al., 2008). However there is a lack of research using this model with eating disordered behaviour. Investigating the role metacognitions have upon eating disordered behavior will help shape understanding of what may predict such behaviour, and also assist in the future treatment of

disordered eating behaviour.

Study 2

Perfectionism has long been linked to disordered eating (Moor, Vartanian, Touyz & Beumont, 2004) and is viewed and treated as a maintaining factor in the transdiagnostic model of eating disorders (Fairburn, Cooper & Shafran, 2003a). The method of intervention based on this transdiagnostic model (Enhanced Cognitive Behavioural Therapy) has been found to significantly reduce perfectionism and eating disorders, and is widely used (Fairburn et al., 2011).

Research suggests that shame also plays a critical role in disordered eating (Markham, Thompson, & Bowling, 2005), and those with disordered eating have been found to have higher levels of shame than other clinical groups (Cook, 1994). Compassion Focussed Therapy for Eating Disorders was designed to specifically target shame and self-criticism in the context of disordered eating, and has shown promising results in the treatment of eating disorders (Gale, Gilbert, Read, and Goss (2012).

Both perfectionism and shame have been found to independently predict levels of disordered eating, with perfectionism being the strongest predictive factor (Cella, Cipriano, Iannaccone & Cotrufo, 2017). However, the literature is unclear whether this perfectionism/disordered eating relationship is mediated by shame, and whether it would continue to exist if shame were controlled for. Fully understanding the roles of perfectionism and shame and their interaction in relation to disordered eating is critical to provide the most effective treatment for disordered eating.

Do I have to take part?

No, it is your choice whether to participate or not. If you do decide to take part you are free to change your mind and withdraw from the study at any time. Please keep a note of your ID number in case you wish to do this at a later date.

What I will happen if I decide to take part?

If you want to participate in this study, you will be invited to ask the researcher any questions you may have and will be asked to electronically sign a consent form.

Methodology

Firstly, we will ask you to provide some background information about you that will be non-identifiable. We will ask you to include your phone number as your personal ID. (This will be the number you use should you wish to withdraw from this study at any time).

You will then be asked to fill in a total of 7 questionnaires. Information about each questionnaire is below:

- 1) A questionnaire about your beliefs about your thoughts
- 2) A questionnaire about eating behaviour

- 3) A questionnaire about how we control thoughts
- 4) A questionnaire about loneliness
- 5) Two questionnaires about feelings of shame
- 6) A questionnaire about traits of perfectionism

The total time taken to complete the study will be approximately 45 minutes-1 hour.

Once you have completed the questionnaires you will be given a debrief sheet and an opportunity to email the researcher with any questions you may have.

You will then be contacted in 6 months' time to invite you to take part in an identical follow up questionnaire This will allow us to see whether there are any changes over time.

What are the possible disadvantages of taking part?

There are minimal anticipated disadvantages to participating in the study. You will be asked to give an hour of your time. You are free to withdraw from the study and/or speak to the secretary of the ethics committee (see details below).

What are the possible benefits of taking part?

If you are part of Cardiff University you will be awarded with EMS credits. If you are outside of Cardiff university you will be entered into a prize draw with a chance to receive £40 Amazon vouchers. Although you may not benefit personally from the study, your participation will contribute to a study that may improve our understanding of how our thoughts and feelings contribute to our eating behaviour and to understanding what the best way to therapeutically support someone with disordered eating.

What will happen to the information I provide?

All information collected about you during the research is strictly confidential and your phone number will be used by us instead of your name to link your responses. Only the consent form will contain identifiable information; which will be solely accessible to the researchers and will be stored separately from your other data, in a locked filing cabinet. All other information you provide will be completely anonymous and stored in a separate locked filing cabinet. The information will be kept for 5 years. You will only be contacted following your participation by text if you win the £40 Amazon voucher prize draw.

What will happen when the study ends?

The results of the study will be written up and submitted to Cardiff University in order to fulfil the requirements for a Doctorate in Clinical Psychology. A report will also be sent to a peer-reviewed journal for publication. You will not be identified in any report or publication that follows this study.

Who has reviewed the study?

The study has been reviewed and approved by an ethics committee panel at Cardiff University.

Contact for further information?

If you feel affected by any of the issues raised in this study, the following may be able to provide help and advice:

- Your General Practitioner
- Secretary of the ethics committee: psychethics@cardiff.ac.uk
- BEAT website:

<https://www.beateatingdisorders.org.uk/>

Thank you for taking the time to read this information sheet.

Appendix E: Consent Form.

If you consent to participating in this study and have read the information sheet, please read and respond to the statements below and sign in the space provided

I confirm that I have read and understood the participant information sheet. I have had the opportunity to consider the information provided, and any questions I may have asked have been answered to my satisfaction.

Agree

Disagree

Q3

I understand that my participation in this study is entirely voluntary and that I am free to withdraw from the study at any time without giving a reason. I also understand that there will be no adverse consequences should I choose to withdraw from the study.

Agree

Disagree

Q4

I understand that my participation is anonymous, and my responses will be recorded without any identifiable information.

Agree

Disagree

Q5

I give my consent to participate in this study.

- Agree
- Disagree

DEBRIEF SHEET

Study 1: Metacognition in disordered eating

Study 2: The relationship between perfectionism and shame in disordered eating

Researchers: Natalie Stott & Elinor MacCormac

Thank you for taking part in this joint study. This debriefing sheet will give you an overview of the purpose of the studies.

What are the aims of the study?

One study examined the relationship between people's worries and the effect of these worries on their eating behaviour. The findings of the study will be used to further our understanding of how our worries can affect eating behaviour.

The other study examined the relationship between traits of perfectionism and feelings of shame in the context of disordered eating. High traits of both perfectionism and shame are associated with disordered eating, but we are examining whether one is more influential than the other. This will help inform the most effective form of therapy for disordered eating in the future.

What are the details about the tasks I completed?

1. The Meta Cognitions Questionnaire measuring beliefs about thoughts
2. The Eating Disorder Examination Questionnaire measuring eating behaviour
3. The thought control questionnaire measuring how often thoughts are controlled
4. The loneliness scale measuring feelings of loneliness
5. The Other as a Shamer questionnaire measures external shame
6. The Internalized Shame Scale measures experience of internal shame
7. The Multi-Dimension Perfectionism Scale measures traits of perfectionism

We asked for some background information so we can examine whether there are any links between different groups of participants and their experiences (for example differences between genders).

Data Protection

All information collected about you during the course of the research is strictly confidential. Only the consent form and your mobile phone number (collected in order to contact you should you win the £40 Amazon voucher prize draw, and to invite you to take part again in 6 months' time) will contain identifiable information. These will be solely accessible to the researcher and will be stored securely for 5 years. The data you provide on the questionnaires will have no identifiable information on it, will be completely anonymous and stored securely at Cardiff University School of Psychology Clinical Doctorate Programme.

Contact for further information?

If you feel affected by any of the issues raised in this study, the following may be able to provide help and advice:

- Your General Practitioner
- Secretary of the ethics committee: psychethics@cardiff.ac.uk
- BEAT website:

<https://www.beateatingdisorders.org.uk/>

Thank you for taking the time to read this debrief sheet and to take part in the study.

To keep up with the research progress and get regular updates, please follow us on Twitter [@MSEDcardiff](https://twitter.com/MSEDcardiff)

Appendix G: Personal Feelings Questionnaire (Harder & Zalma, 1990).

Personal Feelings Questionnaire

For each of the following listed feelings, to the left of the item number, please place a number from 0 to 4, reflecting how common the feeling is for you.

4 = you experience the feeling continuously or almost continuously

3 = you experience the feeling frequently but not continuously

2 = you experience the feeling some of the time

1 = you experience the feeling rarely

0 = you never experience the feeling

___ 1. embarrassment

___ 2. mild guilt

___ 3. feeling ridiculous

___ 4. worry about hurting or injuring someone

___ 5. sadness

___ 6. self-consciousness

___7. feeling humiliated

___8. intense guilt

___9. euphoria

___10. feeling "stupid"

___11. regret

___12. feeling "childish"

___13. mild happiness

___14. feeling helpless, paralyzed

___15. depression

___16. feelings of blushing

___17. feeling you deserve criticism for what you did

___18. feeling laughable

___19. rage

___20. enjoyment

___21. feeling disgusting to others

___22. Remorse

PFQ2 SCORING KEY BELOW : [Shame Proneness Score = Sum S Items]

[Guilt Proneness Score = Sum G Items]

[items with no S or G are “fillers” and not scored.]

S___1. embarrassment

G___2. mild guilt

S___3. feeling ridiculous

G___4. worry about hurting or injuring someone

___5. sadness

S___6. self-consciousness

S___7. feeling humiliated

G___8. intense guilt

___9. euphoria

S___10. feeling "stupid"

G___11. regret

S___12. feeling "childish"

___13. mild happiness

S___14. feeling helpless, paralyzed

___15. depression

S___16. feelings of blushing

G___17. feeling you deserve criticism for what you did

S___18. feeling laughable

___19. rage

___20. enjoyment

S___21. feeling disgusting to other

G___22. remorse

Appendix H: Other as Shamer Scale (Goss, Gilbert & Allan, 1994).

OTHER AS SHAMER SCALE (OAS)

We are interested in how people think others see them. Below is a list of statements describing feelings or experiences about how you may feel other people see you.

Read each statement carefully and circle the number to the right of the item that indicates the frequency with which you find yourself feeling or experiencing what is described in the statement. Use the scale below.

0	1	2	3	4
Never	Seldom	Sometime	Frequently	Almost always
1. I feel other people see me as not good enough.				0 1 2 3 4
2. I think that other people look down on me				0 1 2 3 4
3. Other people put me down a lot				0 1 2 3 4
4. I feel insecure about others opinions of me				0 1 2 3 4
5. Other people see me as not measuring up to them				0 1 2 3 4
6. Other people see me as small and insignificant				0 1 2 3 4
7. Other people see me as somehow defective as a person				0 1 2 3 4
8. People see me as unimportant compared to others				0 1 2 3 4
9. Other people look for my faults				0 1 2 3 4
10. People see me as striving for perfection but being unable to reach my own standards				0 1 2 3 4
11. I think others are able to see my defects				0 1 2 3 4
12. Others are critical or punishing when I make a mistake				0 1 2 3 4
13. People distance themselves from me when I make mistakes				0 1 2 3 4
14. Other people always remember my mistakes				0 1 2 3 4
15. Others see me as fragile				0 1 2 3 4
16. Others see me as empty and unfulfilled				0 1 2 3 4
17. Others think there is something missing in me				0 1 2 3 4
18. Other people think I have lost control over my body and feelings				0 1 2 3 4

Appendix I: Eating Disorder Examination Questionnaire (Fairburn & Beglin, 1994).

EATING QUESTIONNAIRE

Instructions: The following questions are concerned with the past four weeks (28 days) only. Please read each question carefully. Please answer all the questions. Thank you.

Questions 1 to 12: Please circle the appropriate number on the right. Remember that the questions only refer to the past four weeks (28 days) only.

On how many of the past 28 days	No days	1-5 days	6-12 days	13-15 days	16-22 days	23-27 days	Every day
1 Have you been deliberately <u>trying</u> to limit the amount of food you eat to influence your shape or weight (whether or not you have succeeded)?	0	1	2	3	4	5	6
2 Have you gone for long periods of time (8 waking hours or more) without eating anything at all in order to influence your shape or weight?	0	1	2	3	4	5	6
3 Have you <u>tried</u> to exclude from your diet any foods that you like in order to influence your shape or weight (whether or not you have succeeded)?	0	1	2	3	4	5	6
4 Have you <u>tried</u> to follow definite rules regarding your eating (for example, a calorie limit) in order to influence your shape or weight (whether or not you have succeeded)?	0	1	2	3	4	5	6
5 Have you had a definite desire to have an <u>empty</u> stomach with the aim of influencing your shape or weight?	0	1	2	3	4	5	6
6 Have you had a definite desire to have a <u>totally flat</u> stomach?	0	1	2	3	4	5	6
7 Has thinking about <u>food, eating or calories</u> made it very difficult to concentrate on things you are interested in (for example, working, following a conversation, or reading)?	0	1	2	3	4	5	6
8 Has thinking about <u>shape or weight</u> made it very difficult to concentrate on things you are interested in (for example, working, following a conversation, or reading)?	0	1	2	3	4	5	6
9 Have you had a definite fear of losing control over eating?	0	1	2	3	4	5	6
10 Have you had a definite fear that you might gain weight?	0	1	2	3	4	5	6
11 Have you felt fat?	0	1	2	3	4	5	6
12 Have you had a strong desire to lose weight?	0	1	2	3	4	5	6

Questions 13-18: Please fill in the appropriate number in the boxes on the right. Remember that the questions only refer to the past four weeks (28 days).

Over the past four weeks (28 days)

-
- 13 Over the past 28 days, how many times have you eaten what other people would regard as an unusually large amount of food (given the circumstances)?
-
- 14 On how many of these times did you have a sense of having lost control over your eating (at the time that you were eating)?
-
- 15 Over the past 28 days, on how many DAYS have such episodes of overeating occurred (i.e., you have eaten an unusually large amount of food and have had a sense of loss of control at the time)?
-
- 16 Over the past 28 days, how many times have you made yourself sick (vomit) as a means of controlling your shape or weight?
-
- 17 Over the past 28 days, how many times have you taken laxatives as a means of controlling your shape or weight?
-
- 18 Over the past 28 days, how many times have you exercised in a “driven” or “compulsive” way as a means of controlling your weight, shape or amount of fat, or to burn off calories?
-

Questions 19 to 21: Please circle the appropriate number. Please note that for these questions the term “binge eating” means eating what others would regard as an unusually large amount of food for the circumstances, accompanied by a sense of having lost control over eating.

19 Over the past 28 days, on how many days have you eaten in secret (ie, furtively)? Do not count episodes of binge eating	No days	1-5 days	6-12 days	13-15 days	16-22 days	23-27 days	Every day
	0	1	2	3	4	5	6
20 On what proportion of the times that you have eaten have you felt guilty (felt that you've done wrong) because of its effect on your shape or weight? Do not count episodes of binge eating	None of the times	A few of the times	Less than half	Half of the times	More than half	Most of the time	Every time
	0	1	2	3	4	5	6
21 Over the past 28 days, how concerned have you been about other people seeing you eat? Do not count episodes of binge eating	Not at all		Slightly		Moderately		Markedly
	0	1	2	3	4	5	6

Questions 22 to 28: Please circle the appropriate number on the right. Remember that the questions only refer to the past four weeks (28 days).

Over the past 28 days	Not at all		Slightly		Moderately		Markedly
22 Has your <u>weight</u> influenced how you think about (judge) yourself as a person?	0	1	2	3	4	5	6
23 Has your <u>shape</u> influenced how you think about (judge) yourself as a person?	0	1	2	3	4	5	6
24 How much would it have upset you if you had been asked to weigh yourself once a week (no more, or less, often) for the next four weeks?	0	1	2	3	4	5	6
25 How dissatisfied have you been with your <u>weight</u> ?	0	1	2	3	4	5	6
26 How dissatisfied have you been with your <u>shape</u> ?	0	1	2	3	4	5	6
27 How uncomfortable have you felt seeing your body (for example, seeing your shape in the mirror, in a shop window reflection, while undressing or taking a bath or shower)?	0	1	2	3	4	5	6
28 How uncomfortable have you felt about <u>others</u> seeing your shape or figure (for example, in communal changing rooms, when swimming, or wearing tight clothes)?	0	1	2	3	4	5	6

What is your weight at present? (Please give your best estimate.)

What is your height? (Please give your best estimate.)

If female: Over the past three-to-four months have you missed any menstrual periods?

If so, how many?

Have you been taking the "pill"?

THANK YOU