

Optimal Operation of Soft Open Points to Minimize Energy Curtailment of Distributed Generation in Electricity Distribution Networks

Xun Jiang, Wenlong Ming*, Yue Zhou, Jianzhong Wu

School of Engineering, Cardiff University, Cardiff, UK

ABSTRACT

As a power electronic device, Soft Open Point (SOP) offers increasingly valuable flexible and accurate power flow control for electricity distribution networks. In this paper, SOPs are optimized to minimize energy curtailment of distributed generation. The optimal operating set-points of SOPs are determined by using a multi-period non-linear optimization model. The optimization model adopts minimum energy curtailment of distributed generation as the objective, while considering the constraints of power losses and physical limits of SOPs and power output limits of distributed generation simultaneously. At the input of the model, load variation is considered by generating random power loading conditions via Monte Carlo simulation. As such, the results of minimum energy curtailment of the model can be analyzed statistically. The methodology is demonstrated on a modified IEEE 33-bus system with different SOP cases. The performance of SOP is evaluated comparing to the case without SOP, and the results show that an SOP can effectively reduce minimum energy curtailment by 84% on average. The impacts of location, capacity and number of SOPs on the performance are also analyzed respectively.

Keywords: energy curtailment, distributed generation, soft open point, load variation, Monte Carlo simulation

NONMENCLATURE

Abbreviations

DGs Distributed generators
SOP Soft open point

Symbols

A_i	Loss coefficient of terminal i of SOP
B_{ij}	Susceptance for the electrical component between busbar i and j
G_{ij}	Conductance for the electrical component between busbar i and j
i, j	Busbar number
$i_{t,ij}$	Branch current between busbar i and busbar j in time period t
$j \in i$	Busbar j is neighbouring busbar i and connected to busbar i through an electrical component (for example a transformer or a power line) including the situation of $i=j$
$P_{t,i}^p$	Lower limit to the active power load
$P_{t,i}^Q$	Lower limit to the reactive power load
MEC	The objective function of the optimization model: minimum energy curtailment
N_{\min}, N_{\max}	The lower and upper limit to the power loading conditions in Monte Carlo simulation process
N_t	The number of SOP terminals
$P_{t,i}^L$	Active power load
$P_{i,t}^{DG}$	Real-time power output of DG
$P_{t,i}^{Sub}$	Exchange active power of the substation interconnecting with the upstream grid
$P_{t,i}^{SOP}$	Active power injection of SOP
$P_{t,i}^{SOP,L}$	Power loss of the i th terminal of SOP
$Q_{t,i}^L$	Reactive power load

$Q_{t,i}^{Sub}$	Exchange reactive power of the substation interconnecting with the upstream grid
$Q_{t,i}^{DG}$	Reactive power output of DG
$Q_{t,i}^{SOP}$	Reactive power injection of SOP
S_i^{DG}	Capacity of DG
t	Time
T	Time duration for each time period
$U_{t,i}$	Magnitude of bus voltage
$U_{t,i}^{sub}$	Bus voltage of the substation interconnecting with the upstream grid
$\dot{U}_{t,i}$	Complex form of bus voltage
U_{min}, U_{max}	Lower and upper limits of the voltage magnitude
$u_{t,i}^P$	Upper limit to the active power load
$u_{t,i}^Q$	Upper limit to the reactive power load
y_{ij}	Admittance between busbar i and busbar j
y_{ij0}	Grounding admittance at the side of busbar i in the π -type equivalent electric circuit
$Z_{\alpha/2}$	The upper $100(1-\alpha/2)$ th percentile of the standard normal cumulative probability function, which can refer to z table
$\alpha_{t,i}^{DG}$	DG power angle
$1-\alpha$	Confidence level
$\theta_{t,ij}$	The difference of phase angles of busbar i and busbar j in time period t
$\eta_{i,t}^{DG}$	Capacity coefficient of DG depending on the current external conditions (like the weather)
σ_{MEC_N}	Standard deviation of the N derived MEC values under N random loading conditions

1. INTRODUCTION

Large-scale integration of distributed generators (DGs) in electricity distribution network will incur the violation of voltage and thermal limits of the network. This will require energy curtailment of DGs to satisfy the operation constraints of the electricity distribution network [1,2].

To reduce energy curtailment of DGs, one method is to increase network capacity by renewing or reinforcing the aging assets. However, this conventional method is

always costly and time-consuming. An alternative way is to enhance the flexibility of the electricity distribution network by using energy storage (or pumped storage) [3-4], demand response [5] or flexibility provided by other energy vectors [6]. Improved power forecasting of renewables is also important to reduce energy curtailment [7].

Besides these methods, Soft Open Point (SOP), an advanced distribution-level power electronic device, is verified to have great power controllability. It can not only share the network capacity but manage the flexible energy resources between connected parts of the distribution network. As such, installation of SOPs is potential to reduce energy curtailment of DGs.

Previous studies mainly focus on using SOPs to increase the penetration of DGs in the electricity distribution network [8-11] or maximize the hosting capacity of the distribution network for DGs [12]. Different from these research, the research scenario in this paper considers that DGs have been developed well in the electricity distribution network and they are prespecified in advance. The research interest turns to investigate the potential of SOP in reducing energy curtailment of existing DGs. Moreover, in previous studies the power load is considered to be constant in each time period, while in practice the power load is uncertain in spatial and temporal aspects.

Considering the above issues, this paper is targeted at using SOPs to reduce energy curtailment of DGs in distribution networks. The optimized operation of SOPs to minimize energy curtailment is determined by using an optimization model. At the input of the model, load variation is considered by adopting Monte Carlo simulation method. Benefit of SOPs to energy curtailment reduction will be performed on a 33-bus test system.

2. OPTIMAL OPERATION OF SOFT OPEN POINT TO MINIMISE ENERGY CURTAILMENT

To minimize energy curtailment of DGs, the optimal operating set-points of SOPs are determined by using a multi-period non-linear optimization model. In this section, the optimization model is formulated. Then, Monte Carlo simulation process is depicted considering load variation.

2.1 Problem formulation

The energy curtailment minimization problem is formulated as follows:

$$MEC = \min \sum_i \sum_t (\eta_{t,i}^{DG} S_i^{DG} - P_{t,i}^{DG}) T \quad (1)$$

$$\sum_{i=1}^{N_i} (P_{t,i}^{SOP} + P_{t,i}^{SOP,L}) = 0 \quad (2)$$

$$P_{t,i}^{SOP,L} = A_i \sqrt{(P_{t,i}^{SOP})^2 + (Q_{t,i}^{SOP})^2} \quad (3)$$

$$\sqrt{(P_{t,i}^{SOP})^2 + (Q_{t,i}^{SOP})^2} \leq S_i^{SOP} \quad (4)$$

$$0 \leq P_{t,i}^{DG} \leq \eta_{t,i}^{DG} S_i^{DG} \quad (5)$$

$$Q_{t,i}^{DG} = P_{t,i}^{DG} \tan \alpha_{t,i}^{DG} \quad (6)$$

$$P_{t,i}^{sub,min} \leq P_{t,i}^{sub} \leq P_{t,i}^{sub,max} \quad (7)$$

$$Q_{t,i}^{sub,min} \leq Q_{t,i}^{sub} \leq Q_{t,i}^{sub,max} \quad (8)$$

$$P_{t,i}^{Sub} + P_{t,i}^{DG} + P_{t,i}^{SOP} - P_{t,i}^L = U_{t,i} \sum_{j \in i} U_{t,j} (G_{ij} \cos \theta_{t,ij} + B_{ij} \sin \theta_{t,ij}) \quad (9)$$

$$Q_{t,i}^{Sub} + Q_{t,i}^{DG} + Q_{t,i}^{SOP} - Q_{t,i}^L = U_{t,i} \sum_{j \in i} U_{t,j} (G_{ij} \sin \theta_{t,ij} - B_{ij} \cos \theta_{t,ij}) \quad (10)$$

$$i_{t,ij} = \frac{U_{t,i}^2 y_{ij0} + U_{t,i}^* (\dot{U}_{t,i} - \dot{U}_{t,j}) y_{ij}}{U_{t,i}^*} \quad (11)$$

$$|i_{t,ij}| \leq I_{ij,rate} \quad (12)$$

$$U_{min} \leq U_{t,i} \leq U_{max} \quad (13)$$

$$U_{t,i}^{sub} = 1.02 \quad (14)$$

In the optimization model, minimum energy curtailment of DGs is adopted as the objective function in Eq. (1). Active and reactive power injections of SOPs and DGs are the control variables of the model. Their constraints, including power losses and physical limits of SOPs (Eq. (2)-(4)) and power output limits of DGs (Eq. (5)-(6)), are considered simultaneously. To restrain the impact of the power fluctuation of the distribution network on the upstream grid, the exchanged power of the substation is also constrained in Eq. (7)-(8). Power flow equations, current limits and voltage limits are shown in Eq. (9)-(10), Eq. (11)-(12) and Eq. (13)-(14), respectively.

2.2 Monte Carlo simulation process for load variation

In practice, the time-varying power loads at different busbars of the network are uncertain. Due to their high dimension in spatial and temporal aspects, load variation is considered by generating random power loading conditions via Monte Carlo simulation. These generated power loading conditions are used as inputs of the developed optimization model for analysis. As such, the corresponding results of minimum energy curtailment of the model can be derived and analyzed statistically.

In the Monte Carlo simulation process, the power load at each busbar for each time duration is sampled by the following probability distribution:

$$f(P_{t,i}^L) = \begin{cases} \frac{1}{u_{t,i}^p - l_{t,i}^p}, & l_{t,i}^p < P_{t,i}^L < u_{t,i}^p \\ 0, & \text{else} \end{cases} \quad (15)$$

$$f(Q_{t,i}^L) = \begin{cases} \frac{1}{u_{t,i}^q - l_{t,i}^q}, & l_{t,i}^q < Q_{t,i}^L < u_{t,i}^q \\ 0, & \text{else} \end{cases} \quad (16)$$

Eq. (17) is used as the stopping rule of Monte Carlo simulation [13]. When Eq. (17) is met the samples of load conditions will be good enough.

$$\frac{\sigma_{MEC_N}}{\sqrt{N}} \leq \frac{\varepsilon}{z_{\alpha/2}} \quad (17)$$

The overall Monte Carlo simulation process is presented in Fig. 1. In the process, $z_{\alpha/2}$ of Eq. (17) is set at 1.96 in accordance with the confidence level of 95%; ε is suggested as 0.01MWh/d; The lower limit N_{min} and the upper limit N_{max} to the power loading conditions are set at 20, 1000 respectively.

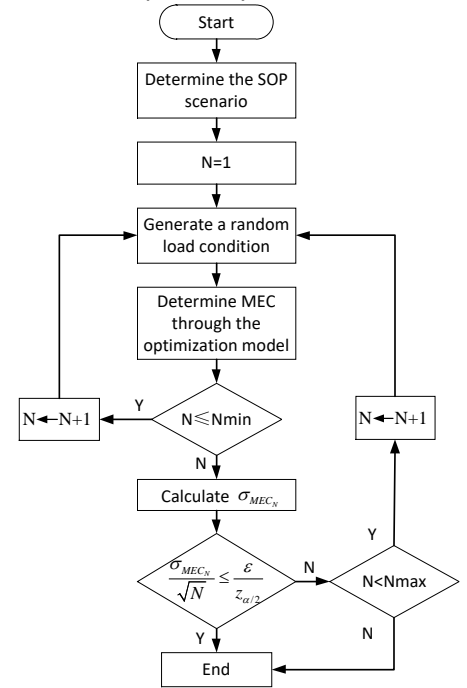

Fig. 1 Monte Carlo simulation process.

3. CASE STUDIES AND ANALYSIS

In this section, a modified IEEE 33-bus distribution network shown in Fig. 2 is used for case study. The distribution network is of 12.66 kV, with 32 branches and 5 normally open tie-lines numbered (1)-(5). The total active and reactive power loads of the power network

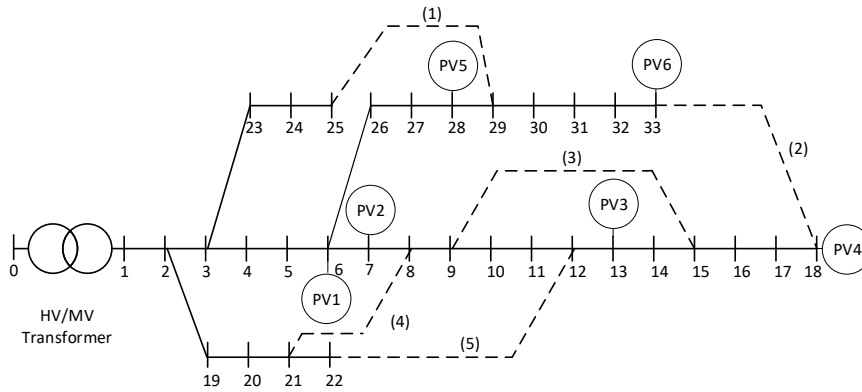

Fig. 2 Modified IEEE 33 busbar medium voltage distribution network.

are 3.715MW and 2.3MVar, respectively. More detailed parameters of the distribution network can refer to [14]. In terms of DGs, six PV systems are sited at busbars 6, 7, 13, 18, 28 and 33 and rated at 1MVA. Fig. 3 shows the daily generation profile for PV systems under study. All PV systems are assumed to operate under unity power factor. Fig. 3 also presents the daily base load profile, based on which $\pm 20\%$ variation is assumed.

SOPs are considered in place of normally open points of the tie-lines. Without special explanation in this study, each SOP is rated at 3 MVA with loss coefficient of 0.02. The power generation of DGs and the operation of SOPs should be restricted considering the operation constraints of the distribution network. $\pm 5\%$ of nominal is considered as the bus voltage limit of the distribution network, while the thermal limits to the branch currents are unified to be 300A. Besides the operation constraints of the network, the exchange power of the HV/MV transformer connected to the upstream power grid is limited within 6MW and 3Mvar.

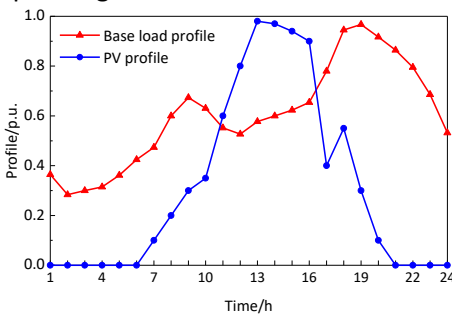

Fig. 3 PV and load profile in 24 hours.

In this section, the developed optimization model is demonstrated on the modified distribution network, and the optimization solution is obtained using the nonlinear optimization solver fmincon in matlab.

3.1 Benefit of Soft Open Point to energy curtailment

To evaluate the performance of SOP in energy curtailment of DGs, the cases with only one SOP installation in tie-lines (1)-(5) are opted for comparison with the case without SOP. For each case with or without SOP, the power loading conditions are sampled through Monte Carlo simulation independently and they are used as input of the optimization model (see Fig. 1). Based on these random power loading conditions, for each SOP case the computation of the optimization model will be conducted many times to get results with statistical significance.

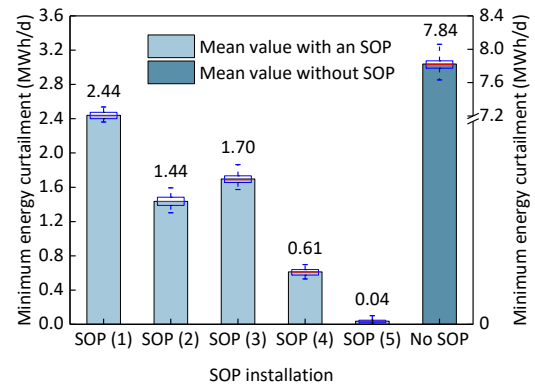

Fig. 4 Impact of one SOP installation on daily minimum energy curtailment considering $\pm 20\%$ load variation.

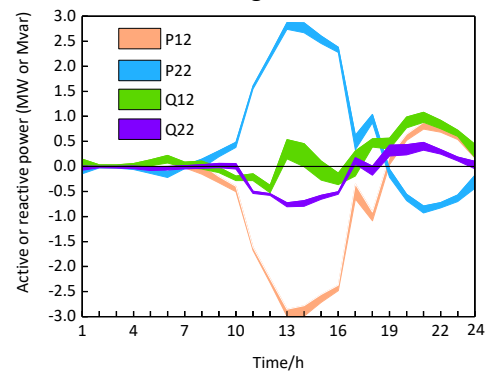

Fig. 5 Operating set-points for SOP installed in tie-line (5) between busbar 12 and 22 considering $\pm 20\%$ load variation.

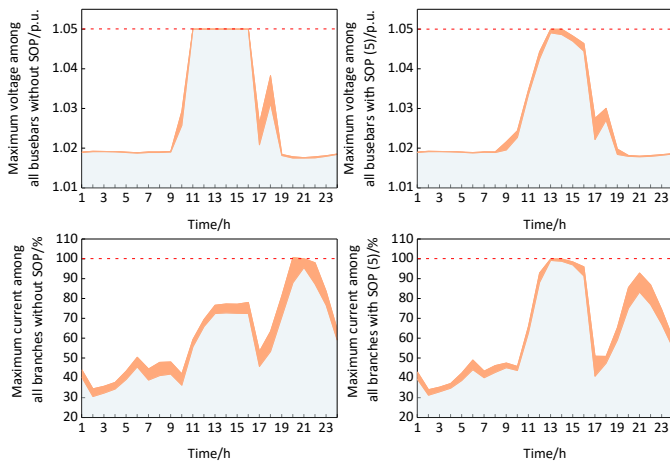

Fig. 6 Range of maximum bus voltages and branch currents considering $\pm 20\%$ load variation.

Statistical results of minimum energy curtailment of PV systems for one day are compared in Fig. 4. In this figure (and also in Fig. 8), each box displays the minimum value, 25th percentile, 75th percentile and maximum value in blue lines and the median in red line.

The overall performance of an SOP can be represented by the mean values of minimum energy curtailment. As shown in Fig. 4, an SOP can reduce minimum energy curtailment by 69%-99% (on average 84%) comparing to the case without SOP. Moreover, the width of the range between minimum and maximum MEC values is smaller than the case without SOP, which indicates that the impact of load variation on minimum energy curtailment can be restrained by SOP.

The optimal operating set-points of SOP, taking SOP installed in tie-line (5) for an example, are shown in Fig. 5. The operating set-points of SOP (i.e. active and reactive power injections from SOP), computed many times under random power loading conditions, will constitute a range between the obtained minimum and maximum values. The corresponding range of maximum voltage (and branch current) among all buses (and branches) in each time period is shown in Fig. 6. It validates that under the proposed methodology, the bus voltages and branch currents can be restrained within upper limits. In addition, bus voltages can be reduced by SOP especially from 11:00am-4:00pm when the generation curve of PV is beyond the load curve in Fig. 3.

3.2 Impact of different Soft Open Point allocations on minimum energy curtailment

3.2.1 Impact of SOP location

As shown in Fig. 4, SOP in different locations has different effect on reducing minimum energy

curtailment. Compared to the case without SOP, SOP in tie-line (5) reduces minimum energy curtailment the most (by 99%), while SOP in tie-line (4) and (2) the second and the third, with 82% and 92% reduction respectively.

3.2.2 Impact of SOP capacity

Fig. 7 shows the relationship between statistical results of minimum energy curtailment and SOP capacity, taking SOP installed in tie-line (5) for an example.

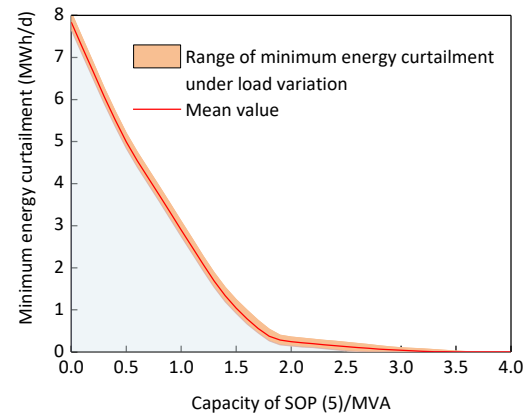

Fig. 7 Impact of SOP capacity on minimum energy curtailment with one SOP installed in tie-line (5) considering $\pm 20\%$ load variation.

As shown in Fig. 7, minimum energy curtailment for one day is generally decreased with the capacity of SOP increasing from 0 to 4MVA. The energy curtailment of DGs can even be eliminated when SOP capacity increases to 3.7 MVA. Moreover, minimum energy curtailment drops fast with the decrease rate of 3.9 MWh/MVA before SOP capacity increasing to 2 MVA.

3.2.3 Impact of SOP number

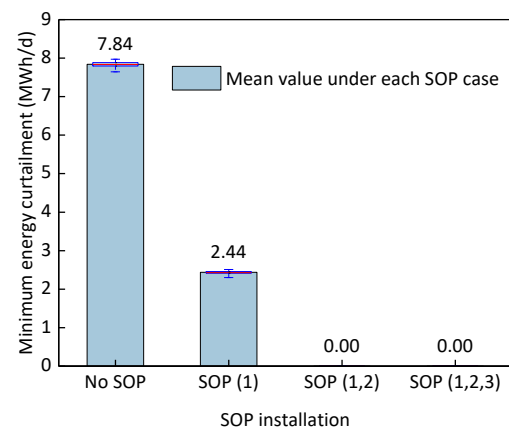

Fig. 8 Impact of SOP number on minimum energy curtailment.

Fig. 8 shows the statistical results of one-day minimum energy curtailment with 0-3 SOPs installed in the network, respectively. SOP (1, 2, 3) represents that

SOPs are installed in location (1), (2) and (3) simultaneously, whereas SOP (1) and SOP (1,2) are expressed in a similar way.

It is observed that one SOP is capable of reducing minimum energy curtailment dramatically, while two SOPs can totally eliminate energy curtailment of DGs in this case. Blindly installing a third SOP is useless to reduce energy curtailment of DGs. Comparing to the case with SOP installed in tie-line (5) (see Fig. 4 and Fig. 7), increasing the number of SOPs installed in tie-lines (1)-(3) is not efficient.

In general, location, capacity and number of SOPs are three important factors influencing the performance of SOPs. A well located and rated SOP is better than two or more blindly installed SOPs.

4. CONCLUSIONS

In this study, optimal operation of SOP has been investigated on minimizing energy curtailment of DGs in electricity distribution networks using a multi-period non-linear optimization model. Considering load variation in practice, random power loading conditions were generated at the input of the optimization model via Monte Carlo simulation. The developed optimization model and Monte Carlo simulation process were verified and demonstrated on the modified IEEE 33-bus distribution system. Through simulation of the test system, the benefit of SOP to energy curtailment was evaluated. The evaluation results show that an SOP under the optimal operation can reduce minimum energy curtailment by 84% on average compared to the case without SOP. Furthermore, the impacts of location, capacity and number of SOPs on the performance of minimizing energy curtailment have been analyzed, respectively.

ACKNOWLEDGEMENT

This work is supported by China Scholarship Council.

REFERENCE

[1] Bird L, Lew D, Milligan M, et al. Wind and solar energy curtailment: A review of international experience. *J Renewable and Sustainable Energy Reviews* 2016; 65: 577-586.

[2] Zhou Q, Bialek J W. Generation curtailment to manage voltage constraints in distribution networks. *J IET Generation, Transmission & Distribution*, 2007; 1(3): 492-498.

[3] Zou J, Rahman S, Lai X. Mitigation of wind output curtailment by coordinating with pumped storage and

increasing transmission capacity. *C 2015 IEEE Power & Energy Society General Meeting*. IEEE, 2015: 1-5.

[4] Cleary B, Duffy A, OConnor A, et al. Assessing the economic benefits of compressed air energy storage for mitigating wind curtailment. *J IEEE Transactions on Sustainable Energy*, 2015; 6(3): 1021-1028.

[5] McKenna E, Grünewald P, Thomson M. Going with the wind: temporal characteristics of potential wind curtailment in Ireland in 2020 and opportunities for demand response. *J IET Renewable Power Generation*, 2015; 9(1): 66-77.

[6] Tang N, Zhang Y, Niu Y, et al. Solar energy curtailment in China: Status quo, reasons and solutions. *J Renewable and Sustainable Energy Reviews* 2018; 97: 509-528

[7] Notton G, Nivet M L, Voyant C, et al. Intermittent and stochastic character of renewable energy sources: Consequences, cost of intermittence and benefit of forecasting. *J Renewable and sustainable energy reviews*, 2018; 87: 96-105.

[8] Long C, Wu J, Thomas L, et al. Optimal operation of soft open points in medium voltage electrical distribution networks with distributed generation. *J Applied Energy*, 2016; 184: 427-437.

[9] Qi Q, Wu J. Increasing distributed generation penetration using network reconfiguration and soft open points. *J Energy Procedia*, 2017; 105: 2169-2174.

[10] Xiao J, Wang Y, Luo F, et al. Flexible distribution network: definition, configuration, operation, and pilot project. *J IET Generation, Transmission & Distribution*, 2018; 12(20): 4492-4498.

[11] Abdelrahman M A, Long C, Wu J, et al. Optimal operation of Multi-Terminal Soft Open Point to Increase hosting capacity of distributed generation in medium voltage networks. *C 2018 53rd International Universities Power Engineering Conference (UPEC)*. IEEE; 2018: 1-6.

[12] Ji H, Wang C, Li P, et al. Quantified flexibility evaluation of soft open points to improve distributed generator penetration in active distribution networks based on difference-of-convex programming. *J Applied Energy*, 2018; 218: 338-348.

[13] Ata M Y. A convergence criterion for the Monte Carlo estimates. *J Simulation Modelling Practice and Theory*, 2007; 15(3): 237-246.

[14] Baran M E, Wu F F. Network reconfiguration in distribution systems for loss reduction and load balancing. *J IEEE Power Engineering Review*, 1989; 9(4): 101-102.