

**Four Houses in London, a ‘back-lot’ development, an example of packed urban dwellings in which privacy, quietness and defensible space are of strategic importance.**

The construction uses an overt materiality to achieve these goals.

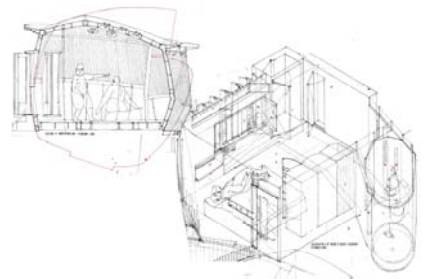

## **Four houses in London: an example of packed housing form**

a. **Year of output:** 2006-2013

b. **Type of output**

Construction of dwellings on site commencing 2010, using insitu methods and prefabricated components.

c. **Title of the output**

Walmer Road : The development of four packed-form houses around a courtyard. For Sale.

Client

Ranova Ltd

Pheonix Homes

(costs undisclosed)

I. Each of the following is required **where applicable** to the output:

a. **Co-Authors:** Collingridge, F.

b. **Interdisciplinary research**

The panel should note that this is a development based on interdisciplinary working involving a range of consultants.

c. **The research group**

Professor Peter Salter, The Welsh School of Architecture

d. **Request to 'double weight' the output:** for outputs of extended scale and scope, the submitting institution may request that the sub- panel weights the output as two (see paragraph I23-I26).

## Aims and objectives

The primary aim was to design and construct four houses around a courtyard, in which the owners although living in close proximity to each other have privacy and quietness between dwellings and in the spaces of the home. These houses are designed for childless couples, individuals sharing the property, or indeed individuals 'downsizing' or preferring solitary living like so many inhabitants of London. The houses are for life-long living with level access, in which ground floor rooms may be converted into bedsitting rooms, and are constructed to have a different sense of permanence and seclusion.

Each house has a particular geometry in its form and orientation, in a 'push me -pull you' arrangement which maximizes the use of floor area across the development and offers each dwelling larger room sizes, a greater sense of space, and affords each room direct sunlight. The courtyard development is orientated towards south sunshine. The geometry reconciles sun angles, privacy and floor area. Another consequence of this geometry are the re-entrant angles that enable secluded balconies to be formed, allowing light to penetrate deep into the plan. The use of such manipulation enables the complex daylight angles associated with 'back lot' development to be maintained.

The design strategy is enriched by the interplay of a series of design rules that enable decisions to be made when intuition runs out.

## Methodology

The research has been conducted through iterative processes conducted with the client, consultants, industry and trade associations over a four year period, tested on prototypes both full size and half scale.

- Construction of a full size room off site showing all the proposed concrete constructions and finishes, in consultation with trade association and industry specialists.
- Construction of a half full size sub frame assembly and bank of timber louvres, in consultation with industry specialists
- Construction of full size fragment of black steel partitioning system, in consultation with industry specialists
- Construction of moulding pieces to test indented render surfaces as an acoustic baffle.
- Construction off site of the prototype timber structure and finishes of the 'Yurt' structures. This included specialist CAD and C&C development.

The research also involved consultants beyond those dealing with the procurement processes: in particular, a concrete consultant, fire consultant, acoustic consultant and a disabled access specialist.

2006-mid 2007: preliminary design discussed with client, daylight consultant and planning consultant . Planning Permission granted.

2007-2009: construction drawing process (undertaken with John Comparelli Architects) involving specialist consultants.

2010 -2013: site architects appointed (Mole Architects) and major review of drawing packages undertaken with consultants, including structural engineer, building regulations, mechanical and services engineer.

A Design and Build Contract agreed in which all construction details are frozen. Contractor appointed.

Demolition and construction begins on brown field site, using a mixture of subcontractors and in-house specialists. Due to the tightness of the 'backlot' site, a split jib crane is installed to move major components around in order to reduce the congestion of the site. Method statements and construction phase planning becomes especially important.

In situ concrete work, an important package, uses an off-site in-house joinery specialist to construct complex formwork, with the simpler made on site.

Black Steel partitions are prefabricated and elements welded on site. Care in the handling of the steel is paramount, due to its mill finish being part of the design aesthetic.

The timber 'yurt' structures are C&C manufactured, pre-assembled and transported at night to London in large segments.

2014 Completion date.

## Dissemination

This has taken place in the following ways:

- Publication of the project and interview with Sutherland Lyle in a dedicated issue of *AJ Specification* (2007) in which all materials, construction method, design and construction drawings were reviewed.
- Publication in *Building Design* (2006, 2012), *Architectural Review* (2011), and as a section in *AD Reader* entitled *Manufacturing the Bespoke* (2012).
- Lectures on the project given by Peter Salter at the following universities: Cardiff, Edinburgh, Newcastle, Lincoln, University College Dublin, Kyoto Institute of Technology Japan, and the Architectural Association School of Architecture (can also be seen online), and most recently the 2013 RIBA Suffolk Evening Lecture given at the *Housing is Architecture* Conference at Snape, Suffolk.  
At the beginning of 2014 there is to be an exhibition held at the Architectural Association, accompanied by a book with contributions by various members of the design and construction team and the client.
- Construction site tours by architectural students and interested architects.

## Authorship

Professor Peter Salter AADipl (Hons) Hon FRIBA (Principal Designer)  
Fenella Collingridge AADipl. (Design Associate)

Working with the following design consultants

Mole Architects

John Comparelli Architects

David Bennett, concrete consultant

Concrete Society

The Timber Frame Company

Simon Ham, fire and means of escape consultant

Andrew Walker, access consultant

Note: The consultants working on production information are not listed

## Site Context

The development is constructed on the brownfield site of a previously derelict group of warehouses and ancillary buildings in West London. The urban and social environment is a mixture of social housing and very expensive, largely renovated Regency villas. Walmer Road has been gradually redeveloped on a piecemeal basis from what was once Victorian brickfields and manufacturing. There is a brick kiln close to the site. It became the setting for the television programme, *Steptoe and Son*. The social housing stock and the remains of Victorian cottages are well built, if not maintained, the later fabric of the area is poor and 'thin'. It carries none of the permanence of earlier structures.

## Context and Significance

Under successive UK governments the construction industry has been encouraged to build on brownfield sites, in order to provide for an increasing population and density of living. This was considered preferable to building on green belt land and the spread of suburbanization in the southeast. The present client is a qualified architect, a principled developer, critical of present-day housing standards and the lack of cohesive communities brought about by mass housing. His current interests lie in small coherent community assisted development of family homes, with adopted communal spaces as part of the development. Walmer Yard (the name adopted for the complex) represents a research into packed close living for childless families or individuals in an inner city environment. It also seeks to counteract the sense of a development based on 20 year building warranties, in which the fabric is layered to a performance specification, often deteriorating at, or before time, requiring extensive refurbishment programmes. This project attempts to reinstate the idea or semblance of permanence, a more monolithic form of building.



## Design Strategy

### Assemblage

Each house has a different plan form, offering the development a variety of accommodation for sale. The client is keen to have as much of the space as possible in private ownership; however, he is also keen that communal areas are taken up and 'adopted' by the residents. This is encouraged by the location of benches for sitting, and pot plant display immediately outside front doors around the courtyard. These continuous benches delineate the extent of property and provide a defensible space for privacy. The communal underground car park has designated vehicular and storage space for each house, to encourage ownership of the space. The particularity of the design of each dwelling does however use a common vocabulary of forms and materials, giving character and identity to the development.



In common with urban living in many European capitals, the development is discreet from the outside, preferring the secluded courtyard for entry. The complexity of form unfolds as the visitor enters the courtyard. Unlike European models, this development is for houses and not apartments. The closeness of dwellings offers an urban rather than suburban quality of space. The courtyard is to be regarded as an outdoor room in which people might choose to come together or not, much like the public room of a Venetian *scuola*

Each house has a different combination of reception rooms at ground level, which is complimented by a range of top floor rooms. The number of bedrooms are thus limited and placed at mid level of each house, enabling the top floor of each dwelling to have a larger volume and scale, a different architectural vocabulary, and the advantage of entertaining and living with a private roof garden. Accommodation normally associated with family life is re-configured to a more suitable plan for an individual who entertains frequently and takes advantage of the cultural milieu of London. The bedrooms are on the middle floor of the houses, this level having a greater circulation between rooms, increasing the sense of privacy of each occupant.



Privacy and quietness are key strategic requirements of the development, especially since the houses are as close as 5 metres across the courtyard; this is achieved by a layering strategy of louvres and acoustic materials. Attention is given to the relationship between airborne sound absorbance externally and internal noise reflections. The combination of external louvres to windows, together with clear openings and bay windows, enables the inhabitants of the house to be offered a range of daylighting possibilities.

The privacy of the courtyard from Walmer Road is protected by raising the level of the courtyard above the street, stepping it back, and allowing the houses to overhang in the manner of medieval jettisoning. Thresholds within the houses are marked by texture and material changes at front doors, similar to those of a Japanese Minka farmhouse. Thresholds are also marked within rooms. Internal doors open onto a seeded and polished concrete threshold; from this the inhabitant steps up onto a timber, raised floor that demarcates the extent of the room. A similar detail is used by Carlo Scarpa in his Venice Court Room.



<b>WALMER ROAD PROJECT</b> for RANOVA LTD Peter Salter architects, John Compagnelli Architects, 235 - 239 Walmer Road, London W11 4EY, Tel: 020 7229 9202	revision	status TENDER	drawing title PROPOSED BASEMENT PLAN
		scale 150 at A1, 1100 at A3	date 23 NOV 2007 sheet WR/L2/01 0



<b>WALMER ROAD PROJECT</b> for RANOVA LTD Peter Salter architects, John Compagnelli Architects, 235 - 239 Walmer Road, London W11 4EY, Tel: 020 7229 9202	revision	status TENDER	drawing title PROPOSED GROUND FLOOR PLAN
		scale 150 at A1, 1100 at A3	date 23 NOV 2007 sheet WR/L2/02





WALMER ROAD PROJECT for RANDVA LTD Peter Salter aad plhns, John Comparelli Architects, 235 - 239 Walmer Road, London W11 4EY, Tel. 020 7229 9202	revision	status TENDER drawing title PROPOSED FIRST FLOOR PLAN
		scale 150 at A1, 1:100 at A3 date 23 NOV 2007 dwg. WR/L12/03



WALMER ROAD PROJECT for RANDVA LTD Peter Salter aad plhns, John Comparelli Architects, 235 - 239 Walmer Road, London W11 4EY, Tel. 020 7229 9202	revision	status TENDER drawing title PROPOSED SECOND FLOOR PLAN
		scale 150 at A1, 1:100 at A3 date 23 NOV 2007 dwg. WR/L12/04

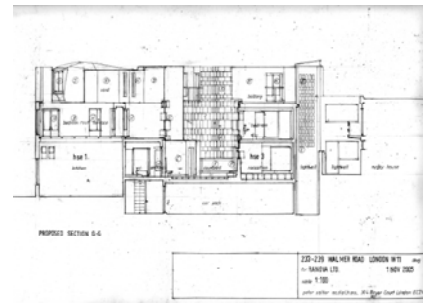
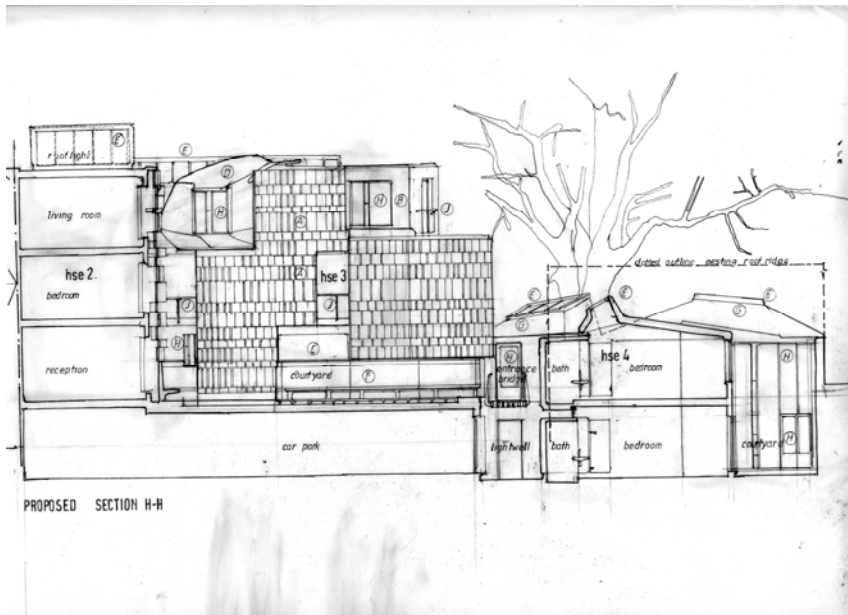
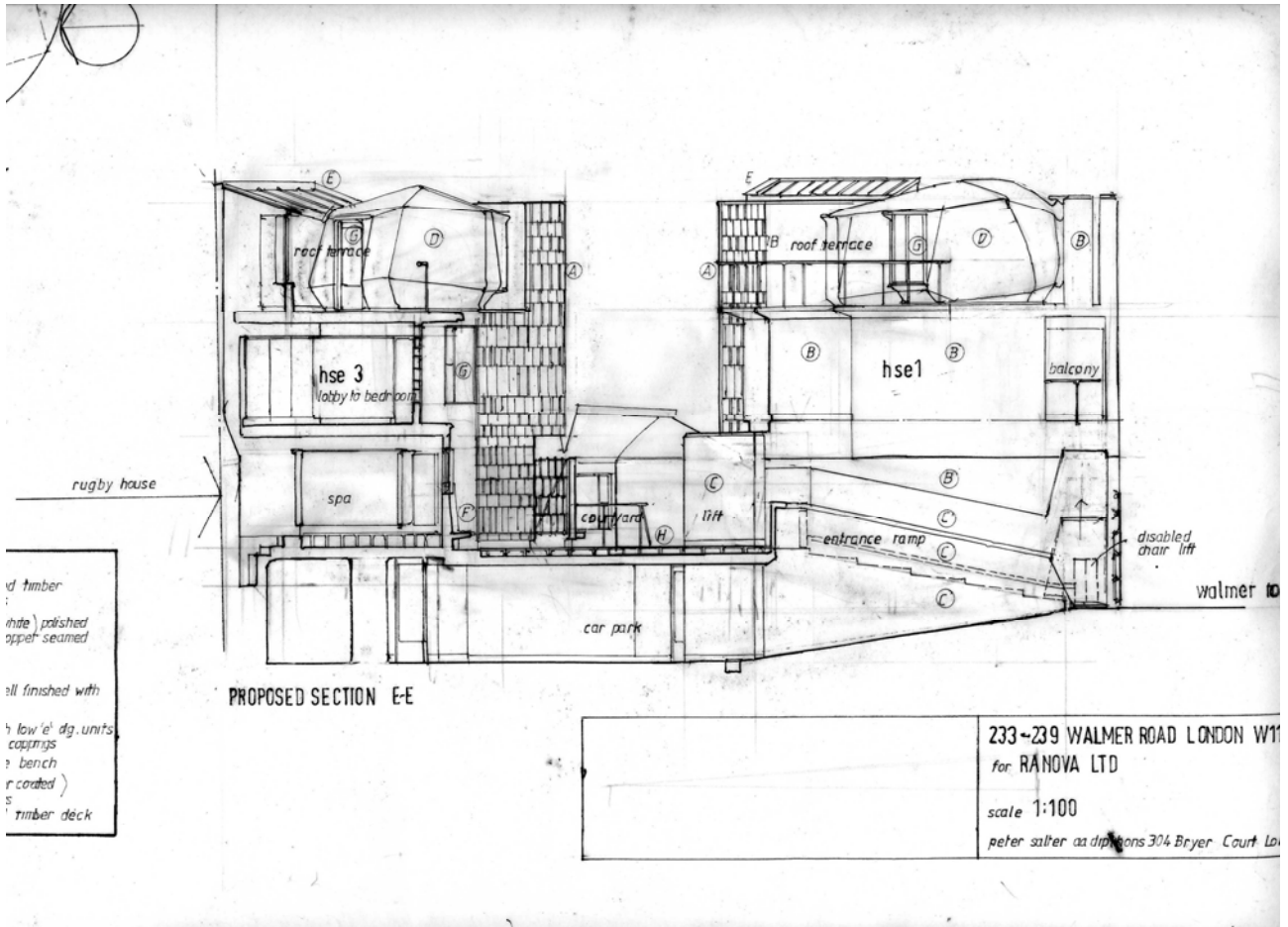

## Sunlight

Each house is formed from its critical relationship to sunlight. The positioning of the ramp to the car park enables the sun angles to be exploited over a greater part of the day, opening up new elevations to sunlight. The entrance to the development almost forms an oculus for the passage of sunlight. One of the houses has a deep plan section, its double aspect exploiting the sun's path across the day. Two of the other houses have shallow plans and wide elevations, to receive single aspect sunlight. In the fourth house, because of the daylight and planning constraints of the surrounding buildings, most of the rooms are naturally lit by large angular roof lights, set in wide coffered soffits. As a result of this strategy, the accommodation of this dwelling is reversed, so that reception rooms are open to the roof lights at courtyard level whereas the bedrooms below receive light from the adjacent private yards. This dwelling straddles a series of these small private yards.

As a general rule, inhabitants on entering the house turn away from the sunlit courtyard and proceed through the depth of the house, usually to the party wall and then turn back either to climb the stairs or enter a room, walking towards the sunlight of the room. The clear opening of the soffit level windows enables light to be reflected across the ceiling of the room. In order to exploit this level of reflection, the majority of the partitions are glazed above door head height, so that upon exiting the staircase, the hall offers a glimpse of daylight before reaching the room. Each room has a family of windows that are appropriate to its function. Close attention has been given to cill heights according to use. For example in bedrooms, bed pillows find a corresponding slot window height whereas sitting room windows are positioned for sitting with the side table corresponding to a window cill level. There is a distinction between windows for view and windows for daylight. The amount of daylight can be tuned by the adjustment of external timber louvres. These louvres either reflect or deflect light, as well as offering privacy from the neighbours' gaze. Unlike the 'Modernist' house, the houses at Walmer Yard generally offer gloom or subdued levels of lighting, reciprocal or contingent to sunlight. In particular, the material finishes make that distinction, an assemblage of degrees of light and shadow. Gloom is regarded as much a quality of space as sunshine. A precedent is the night candle of 18<sup>th</sup> century interiors as seen in a Hogarth painting, in which the brass of a door handle, the gold-leaf of a clock face is reflected by the candle's illumination. The components of the rooms in Walmer Yard follow a similar principle of material in relation to light.

Each floor of each house is regarded as a large room in which object-like elements such as bathrooms are seen as black profiles that dictate movement against the ambient light condition. This strategy has a direct impact on the materials used.

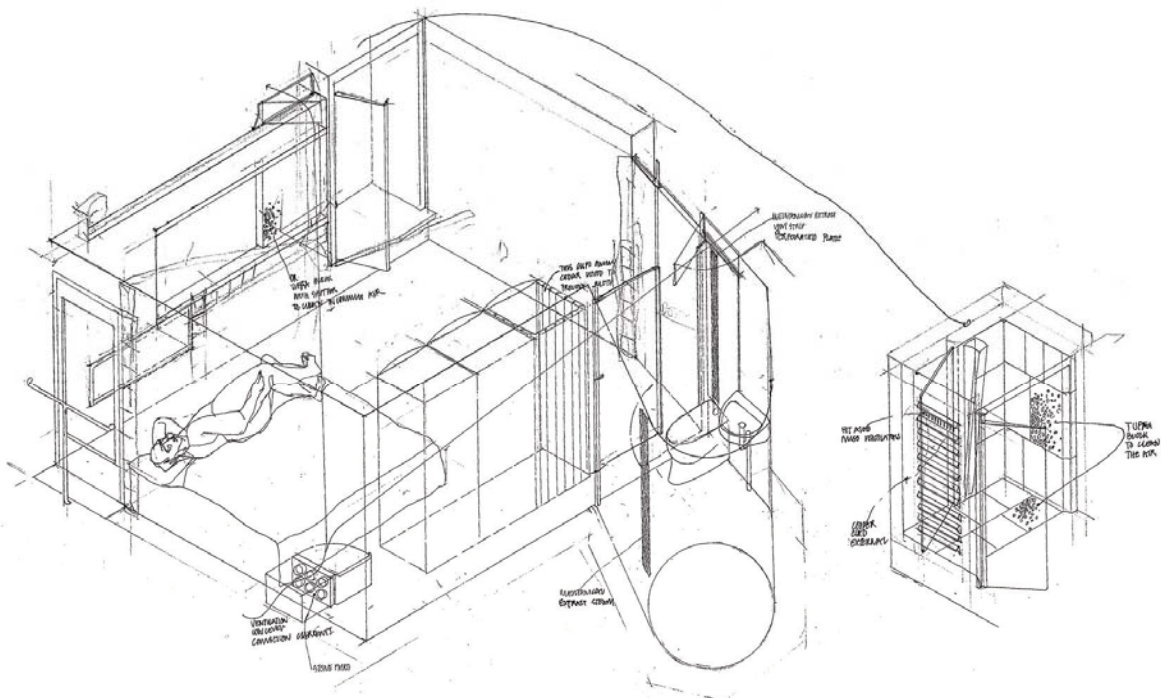

The top floor reception rooms have a different relationship to sunlight corresponding to a different architectural vocabulary – the timber ‘yurt’. Whereas some rooms open to a roof garden and terraces via lantern lights, three of the houses have asymmetrical cold-molded timber structures known to the design team as ‘yurts’. These structures follow the precedent of roof top dining rooms on sixteenth century country houses where supper was served across the ‘leads’ of the roof. The yurt is a darker room intended for evening, in contrast to the bright roof terrace beyond. In these rooms supper is served at low tables.

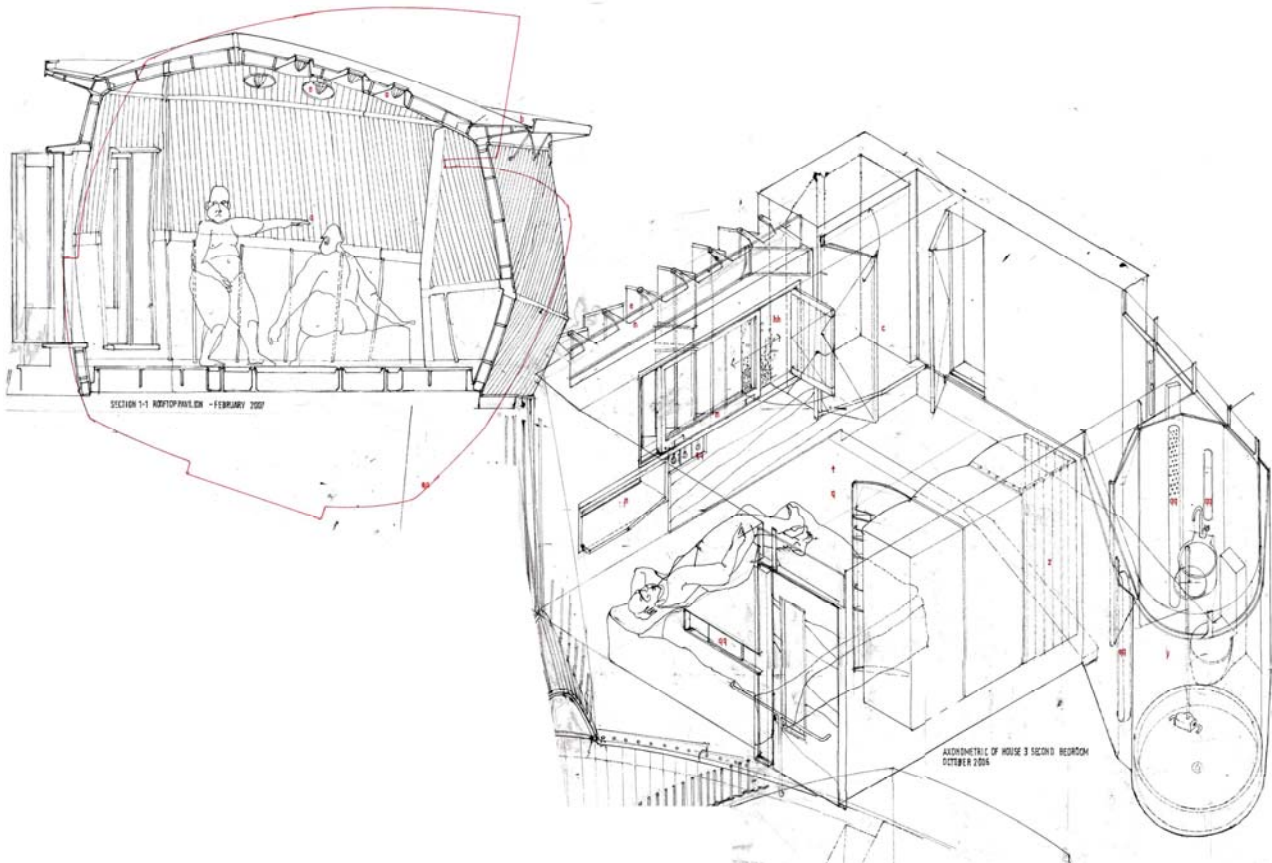

As a speculation, bedrooms and living rooms windows are provided with a tufa block side panel that enables a different air quality to trickle into the room. Each living room is provided with a high combustion wood-burning stove that reduces the SAP rating ‘U’ value from .35 to .20 in line with building regulations of the time.

### Acoustics

Acoustic performance is used as a major strategic design tool, to maintain a cohesive social interaction and sense of responsibility within ‘packed’ urban developments. The courtyard is entered from one corner of the space and the visitor is required to turn the corner before the main orientation of the space is revealed. This ‘dog leg’ provides a sound shadow for the courtyard. As an outdoor room, it seeks to replicate the quietness of a room within the surrounding houses. The courtyard is timber-lined and upon entering, the floor material changes to end-grain woodblock setts that absorb the sound of foot-fall. It is similar to that used in the lodge building of Trinity College Dublin, which receives thousands of students through its portal daily. At Walmer Yard, it creates a sound threshold between the city street and the hoggin-laid courtyard beyond. The elevations around the courtyard are layered with domestic scale reclaimed timber panels. These work in banks of vertically pivoted louvres operated by individual house owners. These louvres are finished so as to reflect light into the house, or adjusted or closed to block neighbouring views. The degrees of adjustment allow airborne sound to be reflected via the louvres to the interstitial cavities of the acoustic render forming the wall surface of the courtyard.

Within the dwellings all walls surrounding the courtyard are cast in insitu concrete. This dense material deflects airborne sound within the room and the house, preventing it from passing between courtyard and room. Impact sounds within the houses are isolated by the timber floors, and in kitchens and dining rooms by vibration resistant industrial cork floor surfaces. The partitions for bathroom pods and other elements are formed from black steel, its density and weight deflecting airborne sound, while dampner materials within the internal superstructure aim to reduce structure borne sound. The glazed fanlights above the steel partitions have a double skin of 6mm Georgian wired glass in particularly sensitive locations.

## Materiality

### Concrete

Use of insitu laid concrete was decided on because of its hand crafted quality of finish, whereby each pour becomes a unique surface, much like that of dressed and striated stonework. The density of the material enables the reflection of airborne sound and gives a quality of stillness to the room. Its massiveness offers a thermal mass in which the material is slow to absorb heat and slow to release heat. The insitu concrete was seen as a warm structure in which all external surfaces are insulated from the outside. This offers the interior of the houses the surface quality of the material. In places where concrete was required both externally and internally, a double skin concrete wall was made, cast in separate pours with the insulation cast into the formwork. The weight of poured and slumping concrete presented a problem when located next to brick party walls. The weight could have undermined the wall. To prevent this, a heavy steel plate was inserted between the wall and the formwork to resist the deflection loads of the concrete. In long stretches this plate became permanent formwork.

### The Test Room

The contractor built off-site a full size room to test the different concrete mixes, finishes, colour, formwork and procedures for building. A 200mm thick x 3.00 m cubic structure was built, in which openings were positioned according to the designed position on site. This made it possible to determine where the likelihood of aggregate bridging might occur, due to insufficient vibration and undercuts forming air pockets preventing proper circulation of the concrete around the formwork. It helped to determine the positions of construction joints to manage pours, or to invent other means of 'venting' the formwork to enable continuous pours. One such example was a particularly circuitous route of concrete around two offset windows. In order to be sure that the concrete mix had reached all corners of the form, 2x 75mm plastic pipes were inserted between the head and cill of particular windows to ensure that the reveals were fully formed. As sacrificial components, these filled pipes were then knocked out and disposed of. The venting positions left ugly round impressions in the head and cill of windows that had either to be covered by a sub-frame assembly or removed by grinding the surface.



### Construction Joints and formwork ties

The sizes and geometry of construction joints were tested for ease of release and scale. Formwork ties were also tested - either snap off cast insitu ties or the reusable tube type. Procurement problems with the Japanese snap off ties, as used by Tadao Ando, led to the use of the tube ties. Alternative casts of open and filled tie positions were explored. It was decided, that in a domestic dwelling such as this, the large diameter formwork ties were out of scale and smaller sections were sought. Eventually, by cutting down the standard conical plug of the tie, a smaller scale definition to the wall was achieved. The ideal positions for the formwork ties as designed were in the middle of the formwork panel; this was seen to be unsatisfactory in some cases as it led to a deflection of the formwork at wall ends. Additional ties were needed to reduce the deflection and consequently the designed layout of ties had to be adjusted.

Kicker heights for joining wall formwork to floors were tested and seen to be an aesthetic refinement rather than a constructional tool, difficult to achieve without making a separate cast.



### Day joints

Day joints in the concrete between construction joints were regarded as bad practice; however these striations formed between pours were very beautiful, almost like land formations. So these were actively sought after in the test room. It was decided to pursue this formation in the building, providing it did not compromise its structure or waterproofing.



### Rule system for concrete finishes

A rule system was invented to determine the position of different finishes. Retaining walls on the boundary were cast using phenolic-faced plywood, with sacrificial triangular fillets that were to be knocked off at a later date, to form a series of striation lines that registered height and datum around the perimeter walls of the development. Another tested finish was board marked concrete which was positioned adjacent to the house boundaries and marked significant features or construction events. Traditional board marking was seen to be too big in scale for the house, so a smaller finer indented board marking was tested. Concrete adjacent to the front doors of houses became fluted or reeded, similar to a Georgian door case; this denoted threshold. Different sizes of fluting in relation to the ease of removing the formwork were tried at the test room. The most critical prototype was that using phenolic faced plywood, in relation to birch faced plywood. As seen in the museum at Naoshima (Tadao Ando), the different materials gave different qualities of light. Both were tested at the room, together with different grades of material and their costs.



### **Phenolic-faced formwork versus Birch-faced plywood**

The Phenolic lined formwork produces concrete that is particularly smooth. Consequently, it is more reflective and the concrete appears brighter and paler than other concretes. In contrast, the birch plywood imprints its grain on the concrete. The cement raises the pattern of the timber, leaving a graining to the finished concrete. As a consequence the concrete surface appears darker as shadow falls across the imprinted grain. On the test site, different methods of raising the grain by wire brushing, soaking the surface, were all tried. However, using the birch faced panel twice as formwork seemed to maximize the graining effect. Different formwork release agents were also tried to again maximize the grain of the birch face formwork and to encourage 'marbling' of the concrete from the phenolic-faced forms. Each had alternative chemical and oil based release agents. It was decided that spraying on a chemical release agent gave better results on birch faced forms, and brushing on oil for the phenolic faced work.

A rule was developed based on the light and shadow characteristics of the formwork. In rooms lying in shadow, where a close reading of the wall surfaces might be experienced - that is bedrooms, living rooms and internal staircases - birch faced plywood was to be used, to a datum of 2.00 metres, corresponding to the junction between fanlight and door /screen head height. Above this level phenolic ply would be used, as a paler more reflective surface to tie into the reflective ceilings. The test room offered a patchwork of shadow and texture which, when used with other materials such as clay boarding, resulted in a room reminiscent of the traditional Japanese house, in terms of its shadow.



## Ceilings

The soffit of the test room demonstrated the need to determine a rule for the finish and scale of the ceiling. Left to chance, the ceiling became a tracery of jigsaw-like formwork that detracted from the calmness of the room. Larger pieces dominated the scale of the room whereas smaller pieces were too busy. Both construction methods offered little in terms of light reflection. The ceiling as a reflective surface was intended to work in conjunction with the high level soffit windows to project and reflect light into the room. At the test site, the soffit formwork was lined with a vinyl sheet. The size 2.400m x 9.00m gave very few joints and the smoothness of the concrete surface reflected light 2.5m-3-5m into the room. The disadvantage was the cast forms of impressed dimples in the soffit surface, caused by the weight of the reinforcement spacers that give structural cover and carry the reinforcement above.



## Board marked concrete

The most important use of board-marked concrete is the plinth to the ground floor level of the Walmer Road elevation. Using the precedent of Carlo Scarpa's board-marked finish, a drawing was made that set out the rules for achieving a similar outcome. This included different percentages of board widths and depths and areas of retarded concrete. What was not accounted for, was the tooled surface of the concrete. Normal board marking, as seen at the National Theatre, involved very little depth differences between boards and large board widths. This gave a monolithic quality to the wall and an over large scale of elevation. At Walmer Yard, the board widths were reduced to a suitable and sympathetic scale of the street and depths of boards were increased to give a more modeled surface. At the test site, the board marked walls gave an overly mannered appearance, and the corners and reveals of openings looked out of plumb as the walls bellied and indented from excessive modulations of depth. The depth also made the removal of the formwork difficult, with pieces of timber left in place, and air pockets leading to a honey combing of the concrete. Large pours would have to be made to subdue the tendency towards cement dribbles between lifts. Different timbers and finishes were also used as board strips, in particular poplar and walnut, wire brushed surfaces, and different release agents. Wire brushed redwood was finally chosen, and areas of board marking where the depths were not so pronounced were preferred. After looking carefully at the test wall, a board depth with a modulation between 2mm and 6mm was adopted as the preferred standard, with an occasional 8mm and vertical stop end before the marking striation began again. It was noticed, that even with a minimum of 2mm projection the light caught the top edge of the board, outlining it in reflected light; similarly, an inset board emphasized shadow. This led to the development of a rule for the entire wall, whereby more projected boards were placed above eye level in a subtle form of cornice, while indented boards were placed at knee level and below. A system of colour-coded drawings formulated the arrangement of board marked concrete on site.





### **Cement content replacement**

To offset the use of cement as a material of high energy production (high embodied energy) and resulting green house gas emissions, it was decided to replace a percentage of cement with a small fines alternative. At the test site, concrete walls were cast using GGBS and PFA, both being the bi-product of coal fired power stations. Structural concrete can use up to 40% PFA content or 70% GGBS content. The resulting walls showed remarkable differences in colour. The PFA gave a grey concrete whereas the GGBS concrete was pale and creamy, with an almost greeny coloured finish. In consultation with the Concrete Society and industry suppliers, various percentages of mix were tested. The use of PFA in the south of England was not common and the batch suppliers were not keen to supply the mix, as batching plants would have to be cleaned before and after the use of PFA. In contrast, the use of GGBS was common in the area of Walmer Road. We chose GGBS. However, the percentage of admix gave very different colour variations. Bearing in mind the room qualities, it became a critical decision. In the end 35% GGBS was chosen as the standard mix throughout the building. Other buildings, such as the Café at Chiswick House, have chosen 50% GGBS, which has given a much paler concrete finish.

### **Black steel partitions**

The sense of permanence and an overt materiality associated with insitu concrete is complimented by the use of 'Black Steel' for partitions and superstructure.

So-called black steel is a steel that comes directly from the rolling mills of South Wales. Seeing it transported by train, truck after truck, one is aware of the mill scale and carbonization left on the surface of the steel from the processes of manufacture. It is this surface bloom, this quality of material that so many sculptors like Richard Serra have chosen to exploit. In order not to destroy such qualities, it is essential that working with this material is kept to the minimum number of operations. To this end, the material is protected by bees wax during manufacturing processes.



The partitions supported on steel sub frames are worked in a way similar to that of a local blacksmith as he cuts and welds steel together for a piece of agricultural machinery. The partitions are made using spot welds and runs of drip weld without further finishing. The grinding back of welds would destroy the patina of the steel. Made on a basic sub frame 44mm wide, the partitions are bent and curved to become self-supporting, widened where necessary to carry services. In some places the material's conductivity is used to provide warm walls. Bathroom elements in black steel are left with a surface protection of bees wax on the hall sides of the houses and are multi-coat painted, much like a tractor part, in the bathroom. In the shower compartment the steel face is lined in mosaic. A full size fragment was made as a prototype, including a piece of door blank. The steel used was 3mm thick; the finish proved too silvery although blue scorch marking and hot spots from welds added to the patina. It was decided that where exposed, the partition should be made from 4mm steel plate; this gave the blue black finish required.

### **'Yurts': roof level timber structures**

These roof level rooms intentionally offer a contrasting architectural aesthetic to the other rooms of the development. The timber structures are asymmetrical polygonal forms that carry some of the internal qualities of a traditional yurt structure. Originally, the structure was to be more aligned to the cold molded techniques of boat building. However, because the structures would not have the same maintenance regime as in boat building, a more usual framing construction was adopted. The out side being lined with copper sheeting that is a mixture of standing seam and diamond tiling. It is without an air gap to maintain and develop the subtle forms of the yurt structure. The void between framing is filled with natural wool insulation, and a special breather membrane copes with the variable seasonal temperatures. This membrane is more akin to an osmotic membrane.

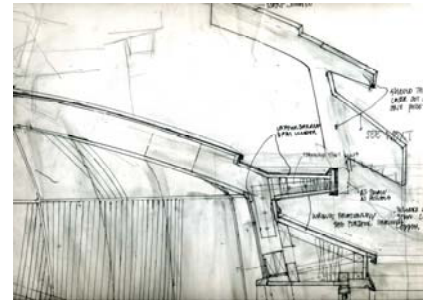
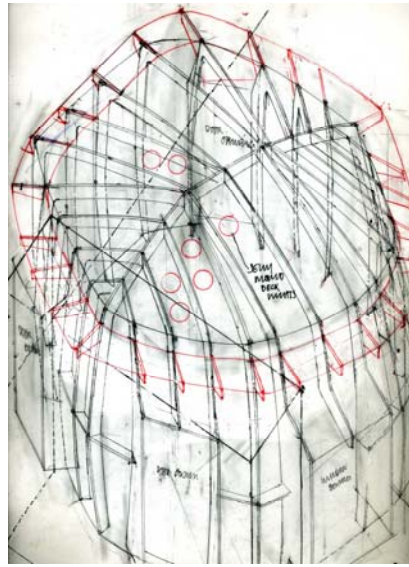
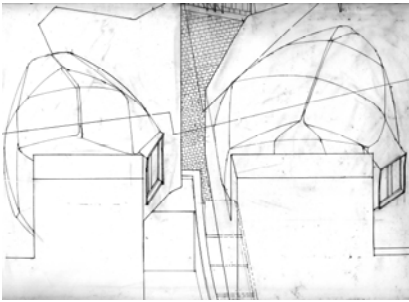

The structure is made as a series of portal frames by C & C routing of plywood sheets. Both the internal and external timber skins are made from diagonal strips laid counter to the two way curvatures produced by the geometry of the frame.

The original forms were determined by making 1:25 scale solid models. The rules of the geometry dictated the number of frames around the base of the unequal polygon. This shape was determined by the spatial characteristics in relation to its location and surrounding structures. Each facet of the base geometry is subtly curved and comes together at a 'chine', which locates the frame structure. Each facet is of a different circumference, depending on its location, so that intermediate frames have to be inserted. Because of the intersection of curves, the chine is quite delicate in its geometry. This gentle change in the skin's direction is of huge importance to the aesthetic of the architecture. The copper skin must reflect these subtle folds of the structure.



The frames, although portal-like in structure, do not necessarily have a corresponding frame member, so that a ridge piece is an important component that transfers load through the frames to the ground plate. The ridge position is determined in the manner of a boat's keel, spanning the space and picking up the framing timbers along its length. This

ridge piece, unlike a keel, is not symmetrical to the space it spans. This became a factor in the making of the structure, the makers thinking of the yurt as being more like a Turkish tent – i.e. the frame pieces would be gathered into a point. This lost the whole sense of the gently warped facets of the space.

Based on the physical models, a Rhino CAD model was built. The structural characteristics were determined and loads checked. The Rhino model allowed the manipulation of the virtual structure, and enabled more subtle changes of slope and geometry to be developed. The final model was given to C&C digital manufacture with part full-size physical components being viewed and understood. The whole structure was assembled in a barn in Somerset, and dismantled for delivery to site by low loader as a series of elemental parts. There are three such structures to be reassembled at Walmer Yard.



## Conclusion

Making architecture always involves research into materials, structure and space, if the building is to work with its context. At Walmer Yard, the material context in relation to physical context, required an extraordinary learning curve, wide-ranging research, and manipulation of technical knowledge and workmanship, in order to achieve greater precision in the qualities of space anticipated.

