

Submitted for revision

The impact of freight transport capacity limitations on supply chain dynamics

(Received 00 Month 201X; final version received 00 Month 201X)

We investigate how capacity limitations in the transportation system affect the dynamic behaviour of supply chains. We are interested in the more recently defined, ‘backlash’ effect. Using a system dynamics simulation approach, we replicate the well known Beer Game supply chain for different transport capacity management scenarios. The results indicate that transport capacity limitations negatively impact on inventory and backlog costs, although there is a positive impact on the ‘backlash’ effect. We show that it is possible for both backlog and inventory to simultaneous occur, a situation which does not arise with the uncapacitated scenario. A vertical collaborative approach to transport provision is able to overcome such a trade-off.

Keywords: Supply chain dynamics; ‘backlash’ effect; transport capacity; vertical collaboration; system dynamics simulation

1. Introduction

A supply chain can be defined as “all parties involved, directly or indirectly, in fulfilling a customer request” including “not only the manufacturer and suppliers, but also transporters, warehouses, retailers, even customers themselves” (Chopra and Meindl 2007). Moreover, between these parties there is an important flow of products, information and cash to be considered when modelling supply chain dynamics (Swaminathan, Smith, and Sadeh 1998). The quicker the flow, the more competitive the supply chain is. These existing flows between the parties render the freight transport carrier responsible for the physical link. This makes transport a “key integral process in contributing to the overall goal of successful supply chain management” (Mason and Lalwani 2006; Mason, Lalwani, and Boughton 2007).

Given the importance of transportation, previous research has shown the impact of supply chain dynamics on freight transport demand leading to the ‘backlash’ effect, that is, the reverse and attenuating flow of shipments towards the downstream company as a result of ‘bullwhip’ (Shukla, Naim, and Yaseen 2009). Given that Shukla et al. (2009) undertook their research studies using the beer game simulation with the assumption of infinite freight transport, in this paper we consider two research questions;

- (1) What is the impact of capacitated freight transport resource on supply chain dynamics?
- (2) How can vertical freight transport collaboration be exploited to best utilise limited freight transport capacity so as to minimise detrimental supply chain dynamics?

Figure 1 provides a schematic of how the paper is organised. In section 2, we review the existing literature on supply chain dynamics and the role of freight transport strategies in supply chain management. We identify the main gaps in current knowledge that lead us to our research questions. Then in Section 3 an explanation of the simulation approach

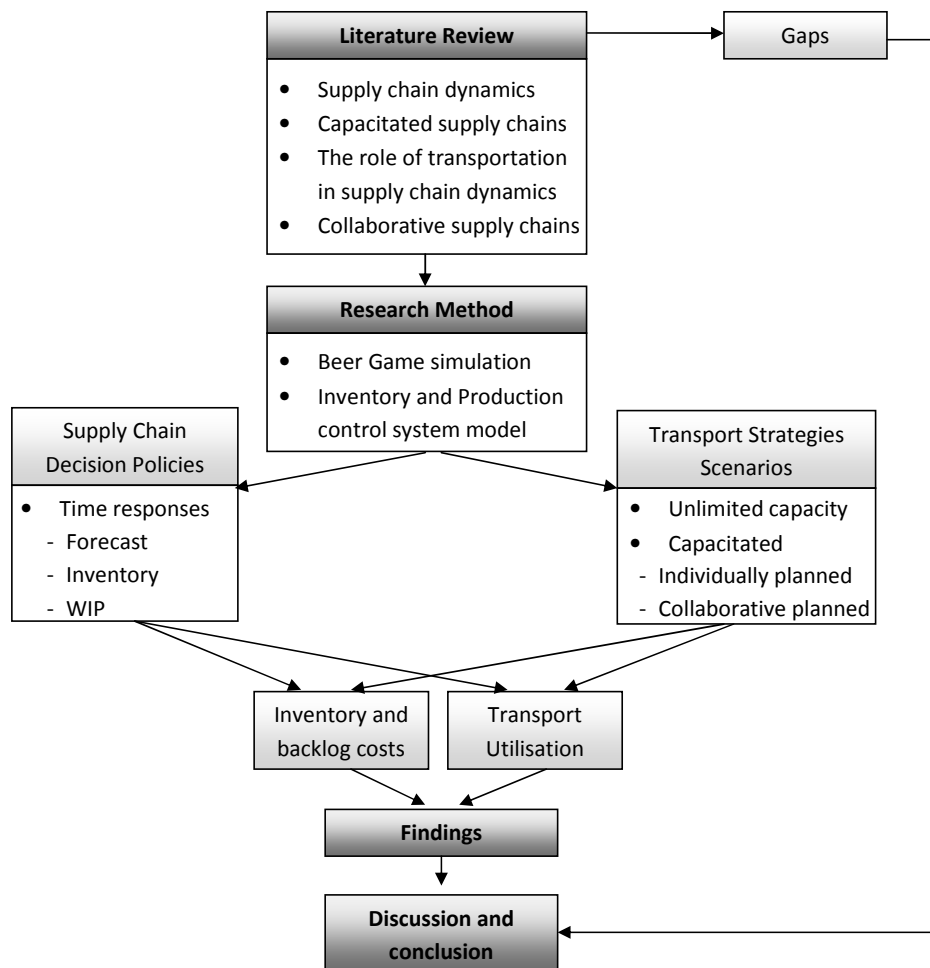

Figure 1. Schematic diagram of this paper

we used to evaluate different production planning decision policies and freight transport scenarios is provided. Section 4 provides a synthesis of our findings through comparing and contrasting the production planning policies and freight transport scenarios in term of their generated supply chain costs and transport utilisation. Finally, in the discussion and conclusion section we present the main contributions of this paper, its limitations and recommendation for future research.

2. Literature Review

2.1 *Supply chain dynamics*

As long as fifty years ago supply chains were recognised as a dynamic system (Forrester 1958). Since then many studies, including those in Table 1, have investigated the causes of such dynamic behaviour in supply chains and to propose mitigating solutions. Forrester's pioneering work produced evidence of variability between production orders and actual consumer demand, encumbering the demand visibility of the last echelon. He deduced that this variability and consequential demand amplification are directly related to material and information delays and feedback loops in the decision making process. Therefore counter measures for this problem would be reducing unnecessary echelons within the system, compressing time and taking due consideration of the design of feedback systems

(Wikner, Towill, and Naim 1991).

Burbidge (1961) identified that stock control based on EOQ (Economic Order Quantity) is another source of demand distortion and amplification. Hence, while the Burbidge effect is related to operational decisions, such as scheduling, batching policies and order priorities, the Forrester effect is associated with structural dynamics in the supply chain (Towill 1997). Thus, Burbidge recommends the reduction of material throughput time and the use of an ordering strategy that synchronises order flow and minimises batch sizes.

Sterman (1989) demonstrated via a table top management simulator, the Beer Game, that the dynamic distortions and amplification in a supply chain are also caused by human misperceptions about inventory and demand information. His suggestion was that improving education, awareness and communication between parties would mitigate the problem.

Later, the phenomenon of demand amplification was experienced by Procter and Gamble and became widely known as the ‘bullwhip’ effect (Lee, Padmanabhan, and Whang 1997a,b). Unlike Sterman, they concluded that even the rational behaviour of the decision-maker can cause demand amplification. They pointed out four main causes of the ‘bullwhip’ effect: demand signalling as per Forrester, order batching as per Burbidge, fluctuating prices and shortage gaming. Information sharing, lead time reduction, single replenishment control, smart price strategies and supply conditions are some of

Table 1. Dynamic distortion in supply chain: causes and proposed solutions

	Root causes	Contributing factors	Counter measures
Demand amplification Forrester (1958)	No demand visibility Information distortion	Information and material delays Wrong assumptions	Removal of unnecessary echelons in the system Time compression Attention to feedback systems
Multi-phasing Burbidge (1961)	Multi-phased,multi-period ordering Batching Long lead-times	Unsynchronised order flow Poor information and uncertainty	Ordering policies adjustment No EBQ system Reduce material throughput time Use small batches
Beer Game Sterman (1989)	Human misperception Wrong assumptions in decision making	No visibility of customer demand	Improve communication between parties Improve education and awareness
‘Bullwhip’ effect Lee, Padmanabhan, and Whang (1997a,b)	Demand signaling Order batching Fluctuating prices Shortage gaming	No visibility of customer demand Multi forecasts Long lead times High order cost Full truck load economies Random or correlated ordering High-low pricing Delivery and purchase asynchronousised Ignorance of supply conditions Unrestricted orders and free return policies	Improve information sharing Access sell-thru and POS data Lead time reduction Single control of replenishment Discount on assorted truckload Regular delivery appointment Every day low price Special purchase contract Allocate based on past sales Shared capacity, capacity reservation
‘Backlash’ effect Shukla, Naim, and Yaseen (2009)	Reflection of orders profile	Ready availability of capacity Occurrence of backlogs	Minimise ‘bullwhip’ Attention to ordering decision rules Capacity management

Extended from: Taylor and Brunt (2001)

the main counter measures proposed by them.

Recently, studies have attempted to describe and understand the distortions that also occur in the freight transport activities. This was first discussed by Holweg and Bicheno (2000) who observed an “amplified and distorted supply pattern” in a steel supply chain and referred to it as ‘reverse amplification’. They affirmed that this effect was caused by supply or throughput constraints since order backlog builds up in case of supply constraints. However, Shukla, Naim, and Yaseen (2009) demonstrated through simulation studies that, even under unconstrained supply, deliveries are commonly higher for the upstream company. Moreover, they further noted that shipment profiles are normally attenuated as they move downstream in the supply chain. Shukla, Naim, and Yaseen (2009) found that this so called ‘backlash’ effect was a reflection of the ‘bullwhip’ effect, analogous to physical waveforms in a channel or pipe.

2.2 *Capacitated supply chains*

Table 2. Relevant research on capacity constrained supply chains

	Method	Capacity in	Key findings
Evans and Naim (1994)	IOBPCS 3 echelons	Order rate	Demand amplification is reduced by capacity Service level is worsened by capacity “Secondary dynamics” appeared
de Souza, Zice, and Chaoyang (2000)	Beer Game simulation 2 echelons	Production	Capacity contributes to dynamics Capacity increase costs
Grubbström and Wang (2000)	Input-output analysis Laplace transforms	Production	Development of an optimal production plan is more complicated in the presence of capacity Costs can be lower when capacity is flexible
Helo (2000)	Simulation model 3 echelons	Production	Flexibility of capacity can mitigate demand peaks Supply chain synchronization and capacity analysis can help to improve responsiveness
Vlachos and Tagaras (2001)	Simulation model 2 ordering rules	Order rate	Capacity limitation has a negative impact on system performance. Early ordering can decrease shortage, specially when demand is variable and capacity is low
Bicheno, Holweg, and Niessmann (2001)	Case-study Value stream mapping tools	Production	Production scheduling can cause dynamic distortions Managing batches, changeover time, Kanban and TPM can minimise inventory even under capacity constraints
Wikner, Naim, and Rudberg (2007)	APIOBPCS	Production	Capacity flexibility (agile policy) helps to ensure lead time expectations of MTO customers but increases dynamic behaviour in the system
Cannella, Ciancimino, and Marquez (2008)	APIOBCS 4 echelon	Production	Demand amplification is reduced when capacity is inputted
Juntunen and Juga (2009)	Reorder point simulation	Transportation (lot sizes)	Lot sizes constraints decrease inventory level Increasing lot sizes does not necessarily improve customer service
Hamdouch (2011)	Non-linear programming, network equilibrium	Production and Storage	Capacity constrains also affect the market demand since the price of the product depends on capacity costs

This section refers to relevant studies that aimed to model constrained supply chains and to investigate the impact of capacity constraints on supply chain performance as summarised in Table 2.

Evans and Naim (1994) used the well established inventory and order based production control system (IOBPCS) archetype to simulate eight scenarios by changing the combination of capacity levels of each echelon in a three echelon supply chain. Multi-Attribute Utility Theory (MAUT) was used to rank each scenario in relation to the other. They concluded that capacity constraints do not always degrade the entire supply chain performance. Also Cannella, Ciancimino, and Marquez (2008), using a variant of IOBPCS, Adaptive Pipeline IOBPCS (APIOBPCS), studied how different capacity levels are related to demand amplification and customer service under different inventory policies and information sharing strategies. They noted that the ‘bullwhip’ ratio decreases as capacity is inserted but they found that an increase in capacity does not necessarily improve customer service.

Different conclusions were achieved by de Souza, Zice, and Chaoyang (2000) and Bicheno, Holweg, and Niessmann (2001). de Souza, Zice, and Chaoyang (2000) aimed to evaluate the impact of seven factors including constraints on production. Results showed that production capacity limitation is the second contributor to increased ‘bullwhip’ and third to increased total cost. It should be noted that while de Souza, Zice, and Chaoyang (2000) used only one level of a capacity constraint in the production, Cannella, Ciancimino, and Marquez (2008) used six capacity constraints levels and Evans and Naim (1994) explored various capacity possibilities along a supply chain, not just in a single echelon. In an empirical case study, Bicheno, Holweg, and Niessmann (2001) also identified that production constraints were the main cause of dynamic distortions in an automotive supply chain. They identified that production scheduling and batching increases demand amplification.

In terms of capacity flexibility, studies point out the importance of having spare capacity to improve responsiveness and to ensure lead-times expectations. On the other hand, the impact of capacity flexibility on total costs is not agreed among the studies since there should be a balance between shortage and capacity-related costs. Grubbström and Wang (2000) found that developing an optimal production plan while taking capacity constraints into account is relatively complicated and that costs would be lower with alternatives where capacity is more flexible.

Helo (2000), evaluated demand amplification in relation to production capacity and the existing trade-off between capacity utilisation and lead times for agile systems. It was concluded that flexibility of capacity can cut demand peaks, so a more flexible production systems may allow companies to produce a product mix with minor variation costs. Moreover, smaller order batches, supply chain synchronization and capacity analysis can help to improve responsiveness.

Wikner, Naim, and Rudberg (2007) evaluated the implications of capacity limitations with a mass customization system and the use of order books to help in managing both volume and lead time flexibilities. The results enabled the adoption of a policy that accounts for capacity flexibility ensuring lead time expectations.

Vlachos and Tagaras (2001) analysed a periodic review inventory system with two supply modes: regular and emergency replenishment orders. They incorporated a capacity limitation in the emergency channel and evaluated two alternative emergency ordering policies: early ordering, to avoid stock-outs, and late ordering until more demand information is available. Simulation results show that capacity has a negative impact on system performance especially when lead times are long. They found that early ordering is preferable to late ordering, especially when demand is variable and when capacity is low.

Hamdouch (2011) showed that capacity constrains not only affect supply chain performance but that they will also affect market behaviour. By using a supply chain network equilibrium model, it was found that since the price of the product is dependent on capacity costs, the market demand will also change. This would imply that the demand will

be even more difficult to be predicted by the upstream organizations hence increasing the chances for ‘bullwhip’ to occur.

Juntunen and Juga (2009) is the only study found in the literature to investigate the effects of transport constraints. However, in contrast to our work, they used a continuous review system, or reorder point method, to analyse the impact of different transport lot sizes on inventory and service levels, whereas we consider the maximum shipment within a time period. They found that the increase in the transport lot size will not necessarily increase customer service. In addition to this, they concluded that small transport lot sizes decrease inventory level and variation. This is consistent with the concept of single piece flow advocated by Lean Manufacturing principles. However, they did not take into account transport costs and utilisation.

2.3 Collaborative supply chains and collaborative transport management

By means of simulation, Potter and Lalwani (2008) evaluated the impact of demand amplification on transport performance. They concluded that the impact of demand amplification was negative and that there is a two-way relationship between supply chain dynamics and freight transport. Not only has the supply chain dynamics an impact on freight transport, but also some decisions made by freight transport management can cause demand amplification. As demonstrated by Juntunen and Juga (2009), managing transport lot sizes may be able to reduce possible impacts of demand amplification and inventory variations, but there is still a need to investigate how a capacitated shipment amount would affect supply chain performance.

In order to overcome some of the difficulties created by the dynamics in supply chains, many potential forms of supply chain collaboration have been proposed. Barrat (2004) categorised these business relationships in two ways: vertically or horizontally. Vertical relationship occurs between upstream and downstream parties of a supply chain. Simatupang and Sridharan (2002) also include the freight transport carrier as part of this collaboration and point out that these companies are willing to share responsibilities, resources and performance information. Vendor managed inventory (VMI), efficient consumer response (ECR) and collaborative planning, forecasting and replenishment (CPFR) are examples of this vertical collaboration. Horizontal relationships include collaboration with competitors, internally among functions and with other unrelated organizations. In such relationships organizations share their private information and/or resources, such as joint distribution centres.

There are several quantitative studies involving collaborative supply chain strategies between customers and suppliers such as: information sharing (Gavirneni, Kapuscinski, and Tayur 1999; Simchi-Levi and Zhao 2003; Hosoda et al. 2008; Hung et al. 2011), Vendor Managed Inventory (Disney, Potter, and Gardner 2003; Disney and Towill 2003; Yugang, Liang, and Huang 2006) and mutual planning of decision policies (Hosoda and Disney 2006; Datta, Christopher, and Allen 2007). However, there are few studies that relate collaborative strategies to transport management. Hong-Minh, Disney, and Naim (2000) used a system dynamics simulation model combined with the Beer Game to evaluate the strategy of emergency transshipment, when a transport route bypasses an echelon in the supply chain, in improving customer service and reducing safety stock. They found that transshipments should occur when, in order to fulfil a customer request, stock at other facilities can be used. Hence, this strategy enhances customer satisfaction and reduces inventory costs although the model developed by Hong-Minh, Disney, and Naim (2000) does not consider freight transport capacity constraints.

Disney, Potter, and Gardner (2003) demonstrated how a more collaborative strategy, such as a vendor managed inventory, can enable batching to minimise transport demand

without negatively affecting the supply chain performance and circumnavigating the trade off between manufacturing and transport functions. However, their dyad model was unable to demonstrate the impact of batching on the ‘backlash’ effect. Similarly, Wilson (2007) showed the benefits of VMI when a transportation disruption occurs. Results indicate that the impact of transportation disruptions is more severe for traditional than for collaborative supply chains. However, beyond the disruption period, manufacturing and freight transport capacity constraints were not taken into account.

It has been argued that vertical collaboration can lower the impact of demand fluctuations on supply chain costs. Vertical collaboration enables the coordination of the assets between different players of the same supply chain and may complement horizontal collaboration between parallel supply chains, so that transport utilisation rate increases (Mason, Lalwani, and Boughton 2007). Inventory costs may be reduced since deliveries can be more frequent and in smaller batches. Moreover, collaboration can increase transport flexibility leading to increased customer satisfaction while also guaranteeing minimization of total costs (Naim et al. 2006).

2.4 *Synthesis of the literature*

Our above review has indicated a number of gaps which, when taken together, justify the need to answer our research questions. There is plethora of literature researching the ‘bullwhip’ effect, both from a quantitative modelling perspective, either conceptually or based on empirical studies, and a descriptive perspective in the form of case studies. There have also been studies that explored capacity constraints on supply chain dynamics but only one that explicitly refers to freight transport issues. Likewise, studies of vertical freight transport collaboration are limited and mostly constrained to conceptual and empirical studies.

There is no previous research that explores the so-called ‘backlash’ effect with the assumption that there is only finite freight transport capacity. Hence, there is no previous research that explores how the negative effect of supply chain dynamics may be mitigated by the adoption of vertical freight transport collaboration.

The collaborative scenarios established in this paper resembles the factory gate pricing approach wherein a retailer will take responsibility for managing and optimising both primary and secondary distribution (Potter, Mason, and Lalwani 2007). Hence typically such an approach will encompass the factory, distributor and retailer who are geographically closely co-located. As will be seen in the next section we will extend this three echelon model to a four level simulation representation simply to ensure consistency with previous research exploiting the Beer Game. While it may be extremely difficult in the real world to vertically collaborate freight transport operations beyond three echelons the model nevertheless provides a powerful means to highlight the theoretical implications of freight transport capacity limitations on supply chain behaviour. The practical implications of the simulation study may then be downscaled from four to three echelons.

3. Research Method

We use system dynamics simulation modelling of the Beer Game (Sterman 1989) with an ordering rule based on the aforementioned Automatic Pipeline, Inventory and Order-Based Production Control System (APIOBPCS) (John, Naim, and Towill 1994). The APIOBPCS is an ordering control system that considers inventories both on hand and in process orders and it is said to be a linear representation of the Beer Game as shown in Figure 2(a) (Mason-Jones, Naim, and Towill 1997; Disney, Naim, and Towill 2000). The same supply chain structure used in the Beer Game was implemented in the creation

of the simulation model. In order to better replicate the Beer Game dynamics with respect to the inclusion of backlogs the difference equations representing APIOBPCS include nonlinearities, which has been recently illustrated by Spiegler, Naim, and Wikner (2012) as in Figure 2(b) . Hence, in order to ensure replication of our study, Table A1 in Appendix A contains the difference equations that are in line with those already used (Shukla, Naim, and Yaseen 2009; Spiegler, Naim, and Wikner 2012). The choice of a simulation approach makes possible the evaluation of different parameter settings and capacity levels. Simulation models serve as a “vehicle for obtaining insight and oversight with regard to alternative supply chain scenarios” (van der Zee and van der Vorst 2005).

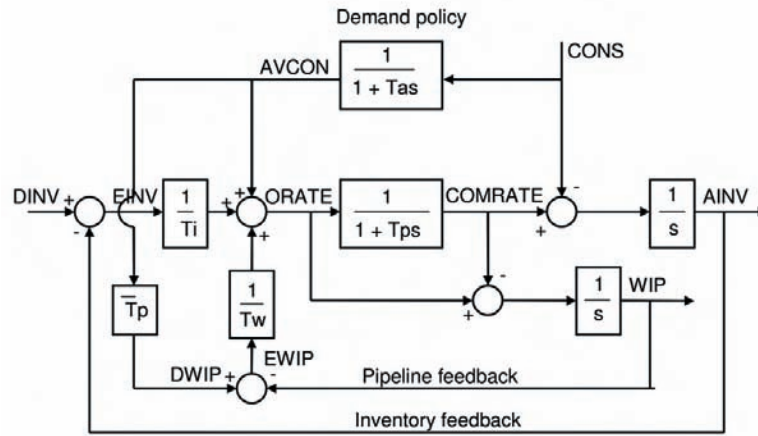

(a) Linear representation of APIOBPCS

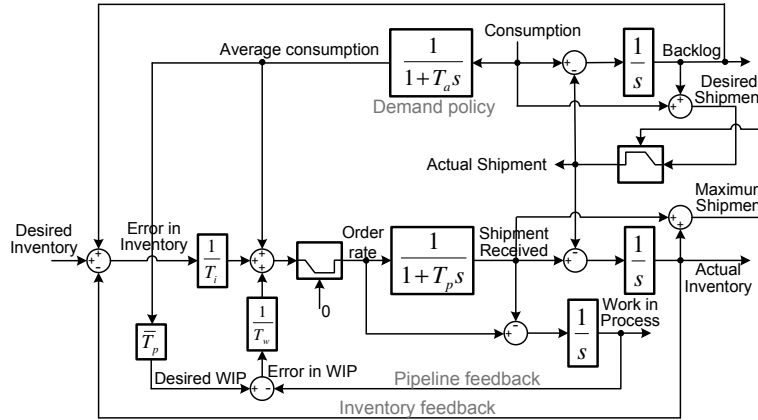

(b) Nonlinear representation of APIOBPCS for replication of the Beer Game

Figure 2. Block diagram

We implemented these equations both in spreadsheets and MATLAB[®] to simulate the supply chain behaviour for several periods after a step change in demand. This model simulates a supply chain consisting of four echelons: retailer, wholesaler, distributor and factory. The total cycle time (lead time T_p) was set at three weeks for every echelon. Any delay in ordering has not been considered, only in shipment. As in the Beer Game, the customer demand has a step increase of 4 to 8 units in week 5. This demand is smoothed and averaged through an exponential smoothing technique, where the smoothing coefficient α corresponds to $\frac{1}{1+T_a/\Delta t}$.

The order placed to the upstream echelon is then the sum of the averaged demand, a fraction ($\frac{1}{T_i}$) of the difference between the desired and actual inventories and a fraction

$(\frac{1}{T_w})$ of the difference between the desired and actual work-in-process (WIP). For the non-linear representation, as given by equation (A1.16) in Table A1, this order rate will be only considered equal to or greater than zero. The upstream echelon receives this request as an incoming order and uses the same logic to place its own orders. The shipments will fulfil the orders only when inventory available as given by equation (A1.6) in Table A1. Only the shipments of raw material are uncapacitated and the factory will always receive what has ordered T_p time periods before.

3.1 Ordering decision policies

The system response will depend on the values of the T_a , T_i and T_w . Previous research recommends different parameter settings that lead to ‘optimum’ behaviour in the system dynamics. Before selecting the decision policies for this research we consider some aspects of the model.

When determining the transfer functions of the linear model in Figure 2, we find that the characteristic equation of the system is given by (1).

$$(s + \frac{1}{T_a})[s^2 + (\frac{1}{T_p} + \frac{1}{T_w})s + \frac{1}{T_i T_p}] \quad (1)$$

Therefore, the natural frequency ω_n and the damping ratio ζ can be determined as:

$$\omega_n = \sqrt{\frac{1}{T_i T_p}} \quad (2a) \quad \zeta = \frac{(T_w + T_p)T_i}{2T_w} \cdot \sqrt{\frac{1}{T_i T_p}} \quad (2b)$$

In this way, we chose decision policies recommended by previous researchers that yield the same natural frequency but three different damping ratios: underdamped, critically damped and overdamped. Hence, we chose:

Design 1: Hardware Analogue ‘Optimum’ Design: $T_a=6$, $T_i=3$ and $T_w=6$. This design was presented by John, Naim, and Towill (1994) and represents a rational rule based on ‘hard’ engineering systems. This set of parameters results in an underdamped system in which $\zeta = 0.75$.

Design 2: ‘Optimum’ Sterman Cost Design: $T_a=1.5$, $T_i=3$ and $T_w=3$. This design was advocated by Sterman (1989) and was based on optimising total cost which compensates the orders in pipeline (OPL). For this design the system is critically damped ($\zeta = 1$).

Design 3: Hardware Analogue ‘Optimum’ Design with Greater OPL Feedback: $T_a=6$, $T_i=3$ and $T_w=2$. This is a variant of Design 1 that is characterised by an increased OPL feedback (decreasing T_w) as in Shukla, Naim, and Yaseen (2009). By increasing this pipeline feedback the system becomes overdamped with $\zeta = 1.25$.

Since we maintained the same value of T_i for all the above designs, the natural frequency is constant and equal to 0.33 rad.s^{-1} . Maintaining the same natural frequency allows the designs to be better compared as we only adjust one characteristic of the model. At the same time by examining known parameter settings we have established benchmarks for our capacity constrained scenarios.

3.2 Creating different scenarios

An important advantage of simulation is that it enables the creating of different scenarios. In this study, five scenarios were considered and the simulation is run for 250 weeks for each design and each scenario.

Scenario A - Uncapacitated supply chain

In this scenario, the model is exactly as represented in Appendix A. The amount that supply chain parties can ship their customers is only dependent on availability of inventory. In this scenario, the ‘backlash’ effect is evidenced and analysed for the different designs. Moreover, this scenario will act as a ‘control’ for the following scenarios where transport capacity constraints are introduced within the supply chain.

Scenario B - Capacitated supply chain with echelons equally constrained

It is possible to only constrain one echelon’s shipment capacity but we found that this gives trivial results and does not yield any further insights to supply chain dynamics than has already been studied in Evans and Naim (1994); Wikner, Naim, and Rudberg (2007) and Juntunen and Juga (2009). All echelons in the supply chain will have their outgoing shipments constrained and each echelon will have the same value for the transport capacity at a given time t ($C_1(t) = C_2(t) = C_3(t) = C_4(t)$). The capacity is modelled as an ‘if...then’ statement, as shown in Algorithm 1, which replaces the shipment ($SHIP_j(t)$) equation A1.6 provided in Table A1. C_j represents a constant transport capacity of which different values can be input.

The desired shipment ($DSHIP_j(t)$) represents what has been ordered by the downstream company, including the current order and backlogged ones. The maximum possible shipment ($MAXSHIP_j(t)$) is related to product availability and includes the actual inventory amount and shipments being received.

This scenario introduces the idea of a supply chain transport capacity (C_{SC}), which represents the total transport resource that the supply chain makes available for its parties. Hence, the available transport capacity is the sum of the individual capacities:

$$C_{SC} = C_1 + C_2 + C_3 + C_4 \quad (3)$$

Algorithm 1 Introducing capacity constraints on shipments

```

1: for  $j = 1$  to 4 do                                     ▷ For each echelon at a time
2:   for  $t = 1$  to 250 do                                   ▷ During 250 weeks
3:      $C_j = constant$                                        ▷ Different constant values can be tested
4:     if  $Min[DSHIP_j(t); MAXSHIP_j(t)] < C_j$  then
5:        $SHIP_j(t) = Min[DSHIP_j(t); MAXSHIP_j(t)]$ 
6:     else
7:        $SHIP_j(t) = C_j$ 
8:     end if
9:   end for
10: end for

```

Scenario C - Capacitated supply chain with echelons proportionally constrained

The capacity of each echelon in this scenario will not be equally but proportionally distributed. The proportions are based on each echelon’s unconstrained maximum shipment. The proportion allocated for each echelon will be the value of the highest shipment

of Scenario A divided by the sum of all maximum shipments. Hence

$$C_j = \frac{\text{Highest Shipment}_j}{\sum_{j=1}^4 \text{Highest Shipment}_j} \times C_{SC} \quad (4)$$

In this way, priority is given to the echelon with the highest shipment requirement, whereas in the previous scenario all the echelons had the same capacity independent of transport demand.

Scenario D - Capacitated supply chain with collaborative transportation

This scenario proposes a vertical collaboration between the echelons of the total supply chain. Instead of inserting individual capacities, only the supply chain transport capacity will be considered. This model represents a supply chain where the parties are willing to share the shipment resources and collaborate on its management or, as in FGP, where one party is responsible for arranging, organising and optimising the transportation considering the whole capacity in the supply chain.

The next step is to determine how to distribute the available capacity. We propose two options:

a) Vertical Collaboration prioritising the downstream echelons - VC_d

In this model, the retailer is the first company to have priority to ship the required goods in an attempt to ensure end customer service levels. Then, the remaining capacity is attributed to the wholesaler, distributor and factory, respectively. For example, if the retailer needs to ship a quantity above the total supply chain transport capacity (C_{SC}), only that total capacity amount will be shipped and all the following echelons will not be able to make deliveries in that time period. Considering a constant supply chain capacity every period t ($C_{SC}(t)$), then Algorithm 2 represents what has been changed in the model displayed in Appendix A.

Algorithm 2 Vertical Collaboration - VC_d

```

1: for  $t = 1$  to 250 do
2:    $j = 1$  ▷ Starting with downstream echelon
3:    $C_{SC}(t) = \text{constant}$ 
4:   while  $j < 5$  do
5:     if  $\text{Min}[DSHIP_j(t); MAXSHIP_j(t)] < C_{SC}(t)$  then
6:        $SHIP_j(t) = \text{Min}[DSHIP_j(t); MAXSHIP_j(t)]$ 
7:     else
8:        $SHIP_j(t) = C_{SC}(t)$ 
9:     end if
10:     $C_{SC}(t) = C_{SC}(t) - SHIP_j(t)$  ▷ Remaining capacity
11:     $j = j + 1$  ▷ Moving to next echelon and repeating
12:  end while
13: end for

```

b) Vertical Collaboration prioritising the upstream echelons - VC_u

This follows the same logic as previously mentioned. However, now we have to allocate capacity to upstream echelons first. Hence, the supply chain total transport capacity will be allocated to the factory first and the remaining capacity to the adjacent downstream

echelon. In this way, we are not prioritising customer service as in the previous strategy Ea), but we are giving priority to companies with higher volume of shipments as evidenced by the ‘backlash’ effect. Algorithm B.1 in Appendix B demonstrates how this process was coded.

3.3 Cost analysis

Since the research method of this study is a simulation approach of the Beer Game (Sternan 1989), the same method of cost analysis used in the Beer Game was here applied in order to evaluate the impact of transport capacity on inventory costs. According to Rushton, Croucher, and Baker (2006), there are three main elements of inventory cost: holding cost, reorder or setup cost and stock-out or backlog cost. The only inventory cost not accounted for in the Beer Game is the reorder cost. However, as it will be shown later in the findings, the order rate is not substantially affected by the introduction of transport capacity. Hence, using the inventory holding and backlog costs will be sufficient for comparing the different scenarios and designs.

For the 250 weeks run in the simulation, we consider a backlog cost of \$1.00 per unit of orders not fulfilled and an inventory cost of \$0.50 per unit held in stock. This cost ratio of 2:1 as in the Beer Game serves also as a benchmark with other studies.

3.4 Transport utilisation analysis

One of the major constraints on transport utilisation is demand fluctuation. Companies that acquire sufficient transport capacity to accommodate peak loads, inevitably run long periods with under-utilised transport resources (McKinnon 2006). Because of this trade-off between transport capacity and utilisation, this study attempts to estimate transport utilisation.

The method used is based on comparing the supply chain total shipment amount with the supply chain transport capacity for a certain period of time. Again, the period of 250 weeks was considered. Thus, if supply chain total shipment is equal to the supply chain shipments capacity for this time period, transport utilisation would be 100%.

4. Supply chain dynamics

4.1 Scenario A - Uncapacitated supply chain

Table 3. Maximum shipments values for uncapacitated Scenario A

Design	Retailer	Maximum shipments			Total	SC maximum total shipment
		Wholesaler	Distributor	Factory		
1	19.86	27.43	33.20	35.01	115.50	99.77
2	20.74	20.74	28.88	31.87	102.23	56.64
3	12.56	12.56	12.56	12.56	50.24	43.40

Figure 3 illustrates the ‘backlash’ effect for all three designs where there are no capacity freight transport constraints. The wave of shipments moves downstream and, with Designs 1 and 2 there is an associated attenuation, while for Design 3, where all the shipments have the same peak amount. Since we are interested in the total shipments made by the supply chain as a whole, this is also illustrated in Figure 3. Designs 1 and

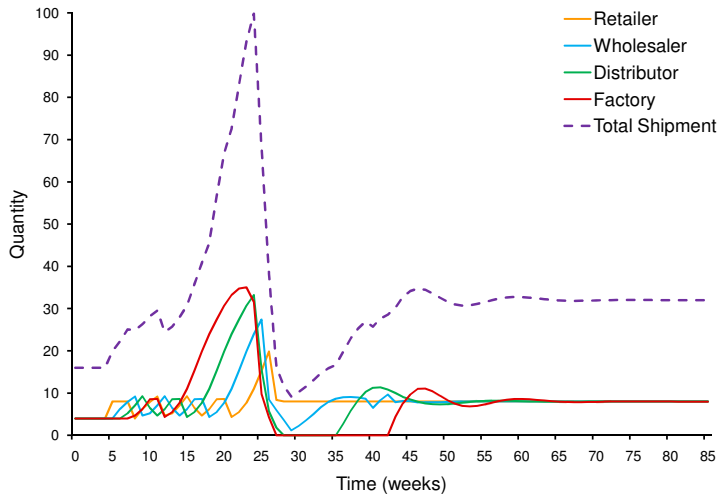

(a) Design 1

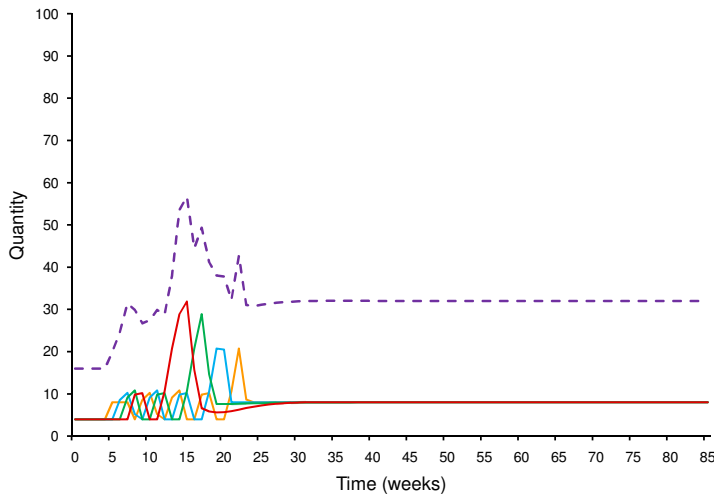

(b) Design 2

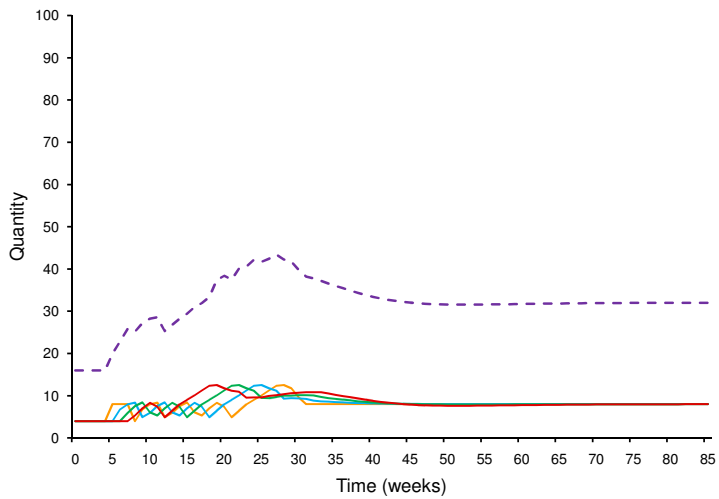

(c) Design 3

Figure 3. Supply chain shipment for Scenario A

2 provide similar peak values of individual echelon shipments, but Design 2 indicates an earlier return to steady state. Design 3 provides less amplification response due to its greater OPL feedback.

Table 3 exhibits the values for maximum shipments for each echelon and the maximum shipment for the supply chain. Note that the demand changes only from 4 to 8 although there are far greater maximum shipments. These results demonstrate that a simple addition of maximum individual capacities gives a false indication of the total freight transport capacity required in the supply chain as a whole. For example, in Design 2, a simple addition of maximum capacities would be 102.23, 80% higher than, the maximum shipment of the supply chain which is only 56.64. This observation points to the importance of a collaborative approach to capacity management between supply chain parties.

Due to the existent discrepancy in Design 2 in relation to planning capacity individually or collaboratively, we use this design to illustrate the impact of a collaborative approach to minimise supply chain dynamics. Figure 4(a) illustrates the shipment, inventory and backlog curves for Design 2 when uncapacitated. When inventory reaches zero, the orders are not fulfilled and backlogs start to build up. At this point, all the echelons increase their orders and all the materials received are dispatched to the next echelon, causing high peaks in shipments.

4.2 Scenario B - Capacitated supply chain with echelons equally constrained

Figure 4(b) illustrates the shipments, inventories and backlogs of each echelon when supply chain capacity is 36. The simultaneous occurrence of inventory and backlog in the factory is demonstrated in the graph. This effect occurs because the factory's outgoing shipment rate is lower than its receiving shipment rate, so inventory rises. At the same time, its outgoing shipment rate is also lower than the order rate, hence backlogs are built up. For the other echelons, additionally to their own transport capacity there is a constraint on their receiving shipments. In this way, these echelons do not build up inventory and cannot meet demand.

4.3 Scenario C - Capacitated supply chain with echelons proportionally constrained

Different proportions of capacity were allocated in terms of shipment quantities required. For Design 2, the factory has the largest amount of goods to ship, thus a higher percentage of capacity was allocated to it.

The results for this scenario when $C_{SC} = 36$ for Design 2 is illustrated in Figure 4(c). Since, both retailer and wholesaler do not possess the minimum required individual capacity, their backlogs and inventories never again reach desired targets.

4.4 Scenario D - Capacitated supply chain with collaborative transportation

4.4.1 Vertical Collaboration prioritising the downstream companies - VC_d

Prioritising the retailer gives more importance to customer service. Hence, the retailer will be able to cover customer demand when inventory is available. On the other hand, the factory will have to hold back its deliveries until a less busy time.

This scenario can be explained by looking at the shipments of Design 2 in Figure 4(d).

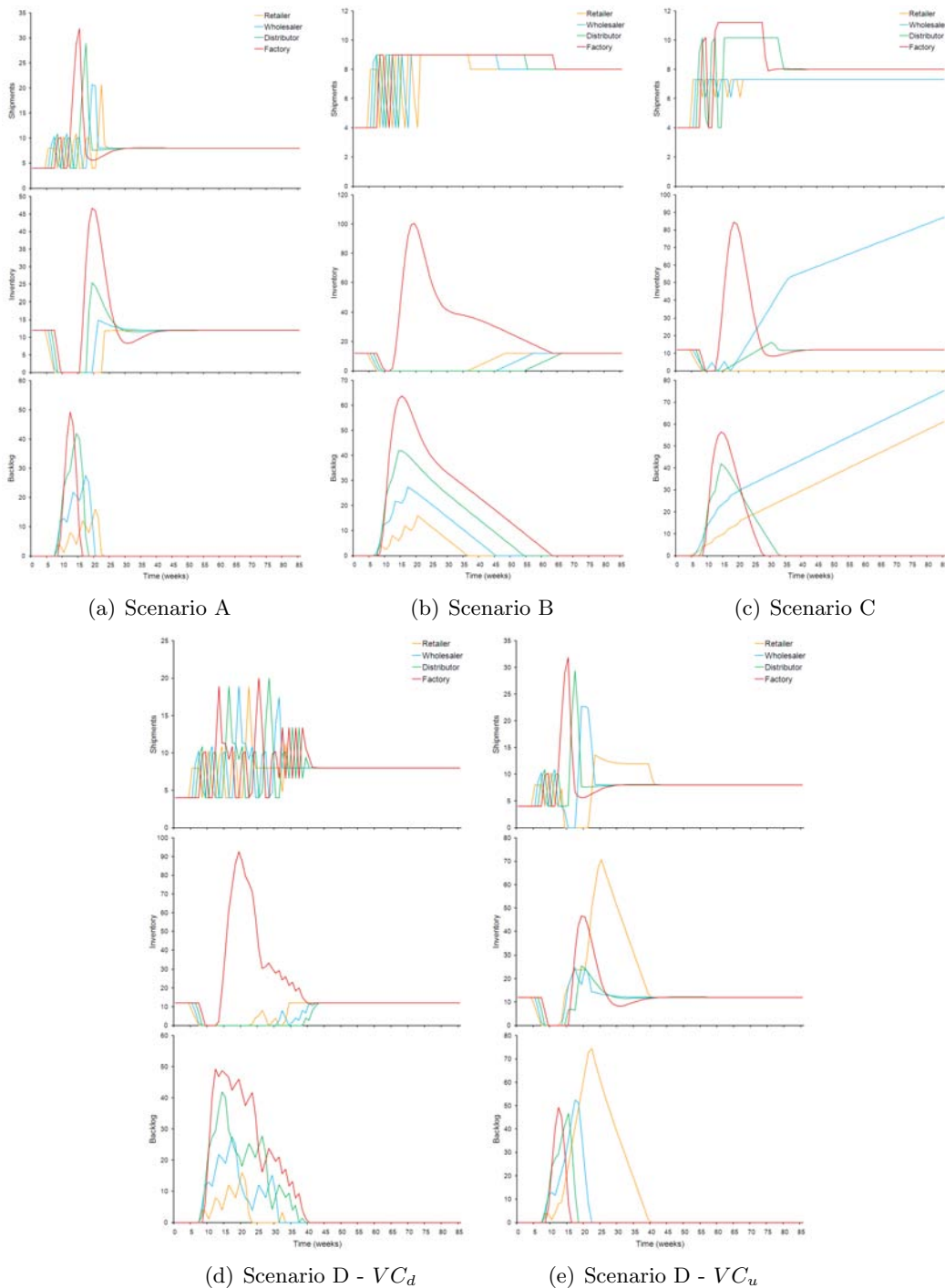

Figure 4. Shipments, inventories and backlogs curves for Design 2 when $C_{SC} = 36$

The retailer starts shipping, but after the initial inventory runs out it starts to ship less, providing more available transport to the upstream party. This is repeated until it is the factory’s turn. This is the point when all the downstream echelons do not have enough available inventories to meet demand because they are not receiving material from the upstream echelon. Thus, the factory is able to ship the first peak amount. After 3 weeks, which equated to a single echelon shipment lead time, the adjacent echelon receives the products and ships them all to compensate for backlogs. When comparing the backlog and inventory levels in this scenario with the equally capacitated one, it is clear that these levels have dropped and they last for a shorter period of time, but their behaviours

are more variable.

4.4.2 Vertical Collaboration prioritising the upstream companies - VC_u

In this case, we decided to investigate how the factory would benefit from being given shipment priority and the impact this would have on customer service due to any backlog at the retailer.

In Design 1, a great volatility in orders and shipments is observed. Moreover, for this design the results are very sensitive to change in capacity. This turbulence could be connected to the presence of “secondary dynamics”. In the other designs, the results are not characterised by disturbances therefore easier to interpret. Since the factory has priority, the retailer is able to ship only when the order rate in the other echelons decreases. Thus, the retailer’s inventory and backlog are high, as given in Figure 4(e). On the other hand the factory’s inventory and backlogs decrease to the same level as in the uncapacitated scenario.

Another notable fact is that, for Design 2, although the individual shipments in this case are different from the ones in VC_d , the supply chain total shipment curve is identical. This implies that both collaborative scenarios provide the same total transport utilisation and on-costs, that is, the increased costs incurred due to fluctuation transport capacity requirements. We discuss such metrics further in Sections 4.5 and 4.6.

4.5 Cost and Transport Utilisation Analysis

In this section we evaluate the impact of shipments constraints on costs and determine which scenario and design achieves the smallest amount of inventory and backlog costs vis--vis freight transport capacity limitations. We assume the usual ratio of backlog to inventory costs being 2:1 (Sterman 1989; Hieber and Hartel 2003)

Figure 5 illustrates the inventory and backlog cost curves in relation to the supply chain transport capacity for Design 2. The proportionally capacitated scenario C results in higher costs until the minimum capacity is reached. After this point, the supply chain perform better in this scenario than in the equally capacitated scenario B. The collaborative VC_d configuration produces the best performance.

The total costs of each scenario and design is demonstrated in Figure 6. For all designs tested, we found the collaborative VC_d of scenario D provides the best performance.

Table 4. Maximum supply chain capacity needed for Design 2

	Maximum capacity needed
Scenario B	128
Scenario C	102
Scenario D (VC_d and VC_u)	57

A trade-off between transport utilisation and capacity was also evidenced. Figure 7 demonstrates how transport utilisation decreases with the increase of supply chain capacity for Design 2. The transport utilisation curves slightly differ for each scenario although there is no difference between the two cases of collaborative supply chains since the supply chain total shipment curves are the same as explained at the end of Section 4.4.

Further information provided by this graph is the maximum amount that is shipped by the supply chain when a certain capacity is reached. For both scenarios B and C, the maximum amount carried by the supply chain increases linearly with an increasing capacity until a certain point. Then it varies until the maximum supply chain capacity is eventually reached. In contrast, the collaborative scenario D the reaches the maximum

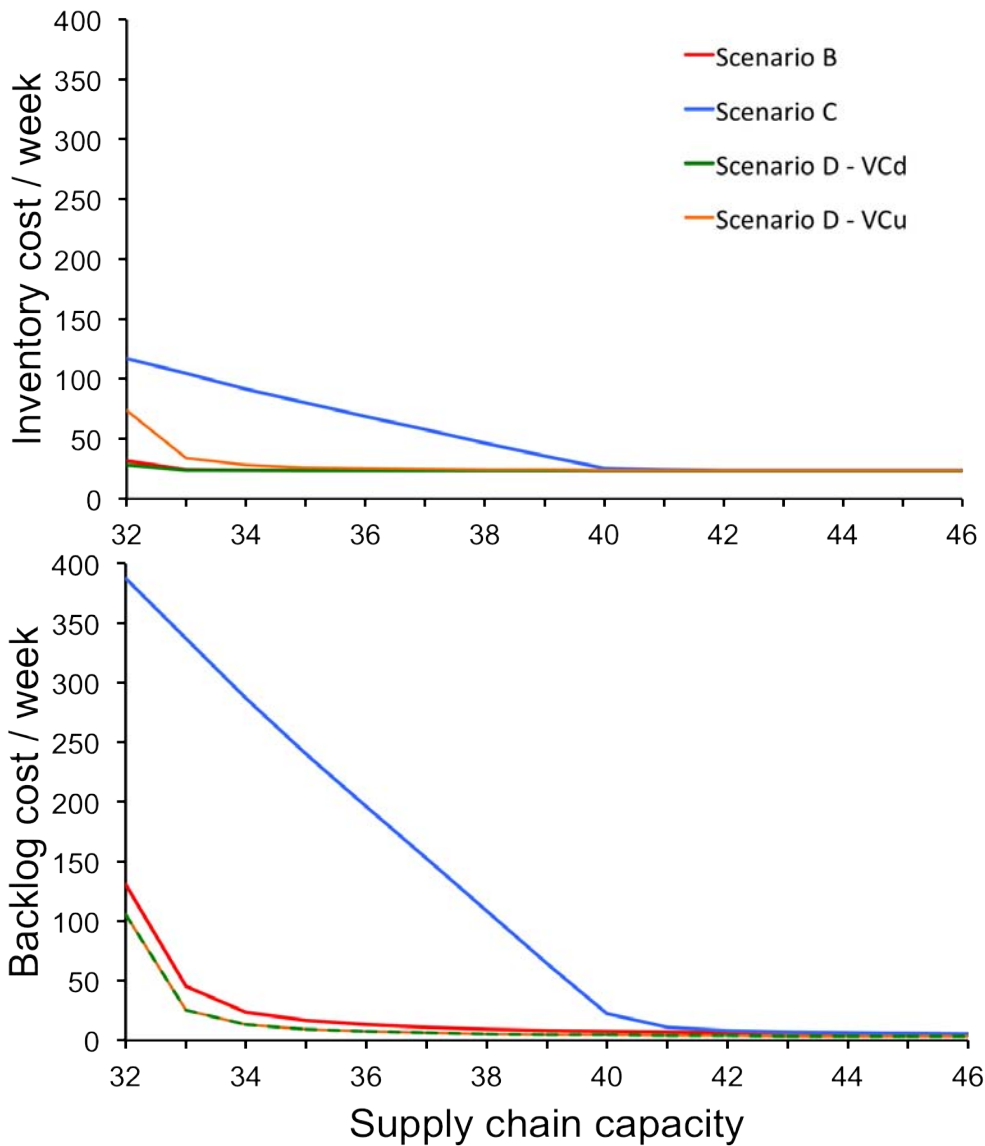

Figure 5. Impact of capacity on inventory and backlog costs for Design 2 - cost ratio = 2:1

capacity needed much earlier. For instance, there is no point in increasing the supply chain capacity above 57 in the collaborative scenarios, because the shipped amount will not increase further. For each scenario, a different maximum supply chain capacity needed was found and is represented in Table 4.

In the equally capacitated scenario B, the supply chain requires more capacity than in the others scenarios to ship the same maximum amount. On the other hand, in the collaborative scenarios, the maximum shipped amount is reached with lower capacity. This is an advantage of the collaborative scenario D because the supply chain can ship its maximum amount with a better transport utilisation than in the traditional scenarios.

4.6 Summary of findings

In order to complement our analysis and to provide enhanced means of comparing the alternative scenarios' performance, we introduced the 'bullwhip' production and 'backlash'

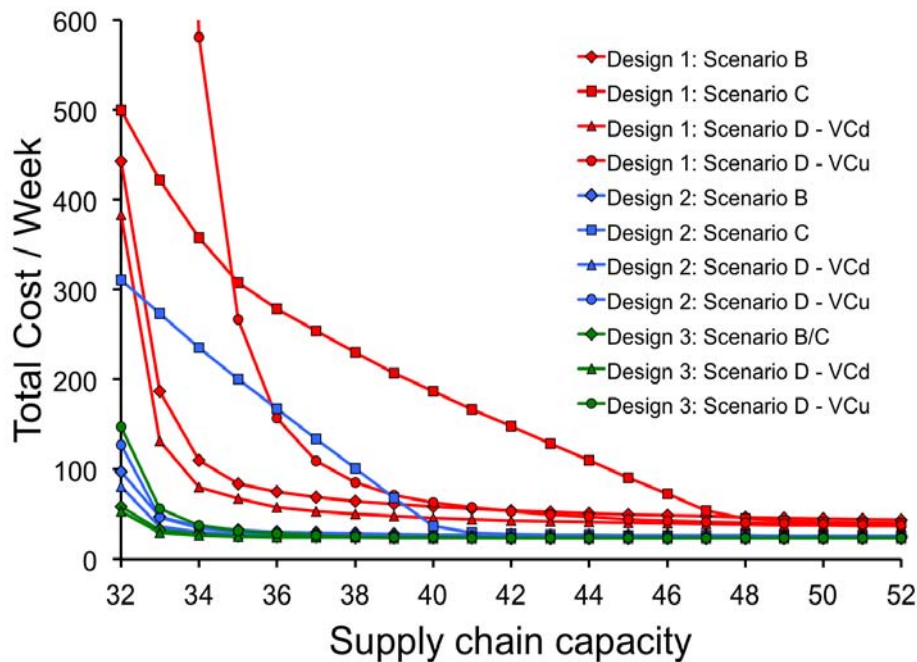

Figure 6. Expected total costs per period - cost ratio = 2:1

transport on-costs as given in Table 5. These on-costs are estimated to be “proportional to the cubic function of the area between the oscillation output and the neutral axis” (Towill, Naim, and Wikner 1992) and reflect the additional costs incurred due to ramping capacity up and down. For the capacitated scenarios we consider again $C_{SC} = 36$. The cubic of the areas between the total order rate and total shipment and their equivalent neutral axis are calculated. While we have concentrated our previous analysis on Design 2 as an example that demonstrates the behaviours associated with capacitated supply chains we consider all three designs in Table 5.

From the unlimited capacity scenario A, it is confirmed that Design 1 performs the worst. High variability of both order and shipment rates and secondary dynamics characterises this parameter set. Design 2 may be deemed as particularly good for supply chains that possess their own transport resources and wish, therefore, to decrease transport fluctuations and to keep low capacity. On the other hand, supply chains that outsource logistics services might be more interested in reducing production on-costs and inventory costs, which from our alternatives would correspond to choosing Design 3.

At the bottom of the table, we highlight which scenarios resulted in the best production and transport on-costs, inventory costs and utilisation. All scenarios C and D in combination with Design 3 resulted in the best ‘bullwhip’ reduction of 38.7% in comparison to the uncapacitated scenario. However, collaborative scenario E (VC_d) also provides good ‘bullwhip’ results, yielding a production on-cost reduction of 27.5%. Great care must be taken in interpreting the results from Scenario D where the proportional capacities create insufficient shipment deliveries and therefore backlogs in the retailer can never be recovered. Despite reducing variations in the order rate, this scenario results in a permanent offset in the shipment curve, hence, in the long term transport on-cost and inventory costs would increase indefinitely.

Collaborative Scenario E, which prioritises the customer, provides the best transport on-costs, inventory costs and transport utilisation performances. Sharing transport resources among members of the entire supply chain contributes to increased utilisation of these resources and also improvement in the service levels by more frequent deliveries and by reducing backlog levels.

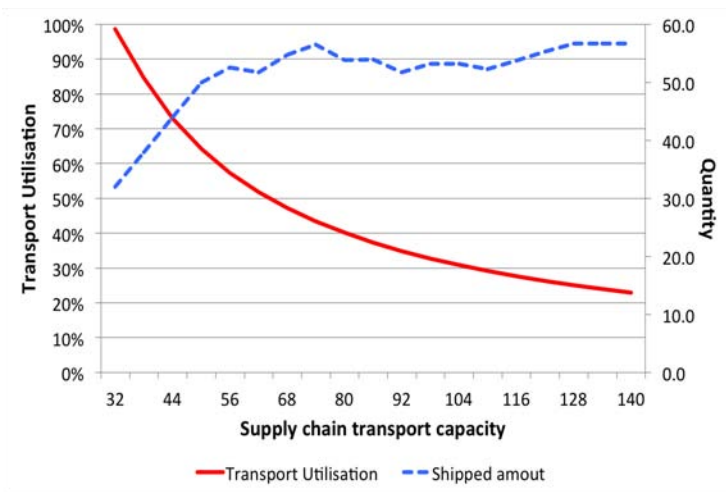

(a) Scenario B

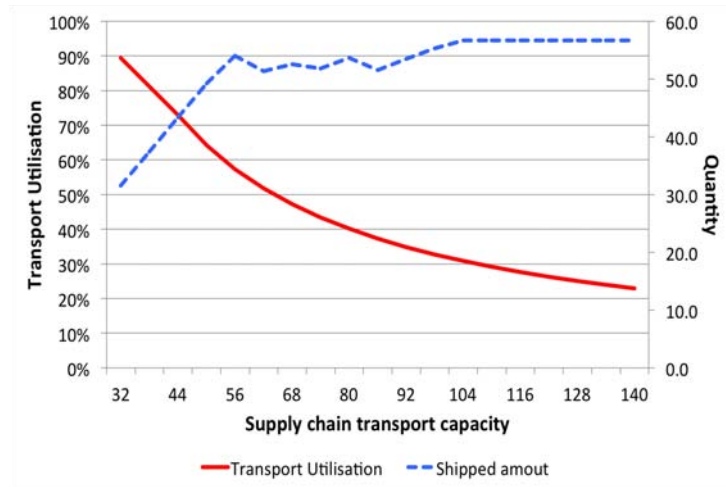

(b) Scenario C

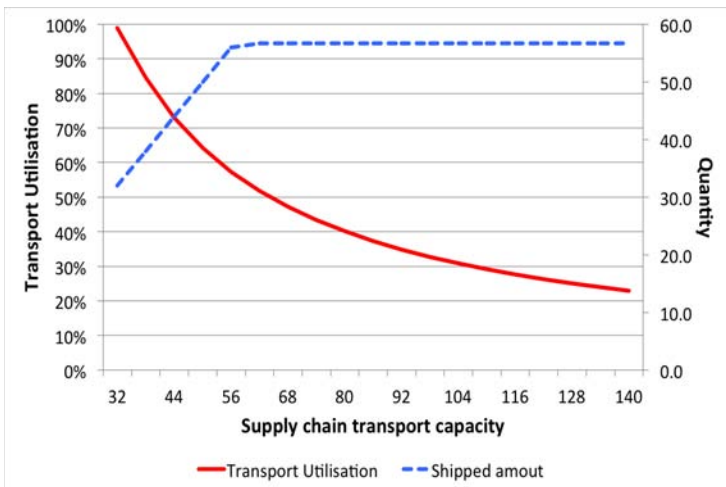

(c) Scenario D (VC_d and VC_u)

Figure 7. Transport Utilisation and amount that is actually shipped for Design 2

Table 5. Summary comparison between unlimited scenario and capacitated scenarios

Scenarios	'Bullwhip' production on-costs (10^6)		'Backlash' transport on-costs (10^6)		Inventory costs	Max. C_{SC} needed	Util.
A	Design 1	1099.10	278.45		33	NA	NA
	Design 2	27.54	3.80		25	NA	NA
	Design 3	14.89	10.36		24	NA	NA
B	Design 1	4904.24 (346.2%)	21.25 (-92.4%)		75 (127.3%)	140	22.9%
	Design 2	27.54 (0.0%)	5.45 (43.6%)		36 (44.0%)	128	25.1%
	Design 3	9.13 (-38.7%)	10.08 (-2.7%)		25 (4.2%)	50	64.2%
C	Design 1	3067.59 (179.1%)	∞ -		279* (745.4%)	115	27.9%
	Design 2	27.54 (0.0%)	∞ -		236* (844.0%)	112	28.7%
	Design 3	9.13 (-38.7%)	10.08 (-2.7%)		25 (4.2%)	50	64.2%
D (VC_d)	Design 1	2755.78 (150.7%)	33.70 (-87.9%)		57 (72.7%)	100	32.1%
	Design 2	27.54 (0.0%)	3.18 (-16.3%)		30 (20.0%)	57	56.3%
	Design 3	10.79 (-27.5%)	9.13 (-11.9%)		24 (0.0%)	44	73.0%
D (VC_u)	Design 1	41064.63 (3636.1%)	712.12 (155.7%)		157 (375.7%)	100	32.1%
	Design 2	27.54 (0.0%)	3.18 (-16.3%)		35 (40.0%)	57	56.3%
	Design 3	14.89 (0.0%)	9.39 (-9.3%)		28 (16.7%)	44	73.0%
Best Capacitated Scenarios		3BC	2D(both)		3D(VC_d)	3D(both)	

* Values were calculated for 250 weeks only and tend to infinity because system reaches permanent offset

These results demonstrate that when deciding on a design, supply chains decision making should be based on which business costs are most prevalent. It should be noted that collaboration among supply chain partners seems to provide the best overall solution for capacitated supply chains.

5. Discussion and conclusion

This work provides insights into the impact of transport capacity on supply chain dynamics. Transport capacity constraints can cause backlogs without necessarily resulting in stockouts. Thus, backlog and inventory costs are increased throughout the entire supply chain. However, with the introduction of transport capacity, the 'backlash' effect is reduced and therefore, transport utilisation increased.

The collaborative scenario, specifically the one prioritising the direct link with customers, obtained better performance in terms of transport-on-costs and inventory and backlog costs. Moreover, less transport capacity is used to ship the total amount of goods needed, hence, providing better transport utilisation. This is consistent with qualitative based research (Mason, Lalwani, and Boughton 2007) affirming that collaboration in transport operations can increase utilisation not only through sharing of assets but also, as demonstrated here, through mutual planning and a whole systems view.

The collaborative scenarios tested in this paper closely replicate a factory gate pricing approach where a retailer manages both primary and secondary distribution. The two collaborative scenarios represent radical cases of vertical collaboration but are viable with a three-echelon representation of a supply network as given in Figure 8. With the factory gate pricing approach, the retailer is able to have visibility of its whole inbound distribution network. Where there is close proximity of suppliers to retail outlets then it is feasible for transport resources to be transferred from one transport leg, or a whole

milk run, to another, therefore creating opportunities for transport cost reduction. Thus, although representing novel cases that may not at this point in time be feasible to practically implement beyond a three-echelon supply chain, the results of the scenarios provide insight into how transport resources in a supply chain should be managed and allocated in order to minimise total costs.

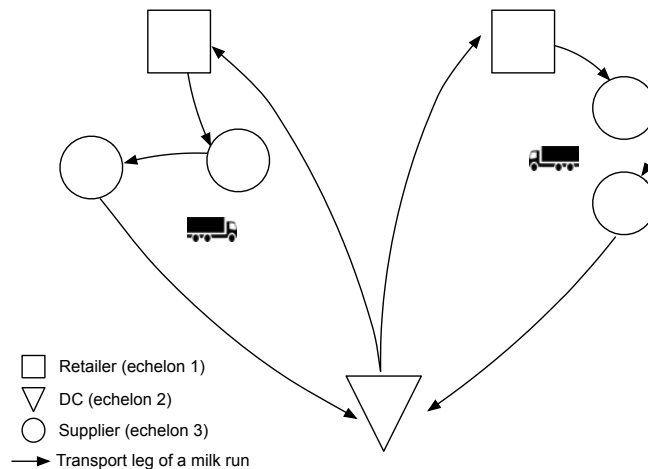

Figure 8. Collaborative approach: factory gate pricing

According to Juntunen and Juga (2009) transport lot sizes should be minimised to decrease inventory variations, but at the same time, we demonstrated that transport capacity constraints should be carefully planned since it may provoke a negative financial impact on the supply chain performance by increasing holding and backlog costs. Hence, while we have focussed on vertical collaboration, it is recommended for future research a more in-depth and elaborated investigation of horizontal collaboration for improving transport operations. Such a transport strategy may reduce the impact of demand fluctuation on supply chain costs and enable deliveries with smaller batches, higher frequency, better transport utilisation and lower costs.

Another limitation from this study is the Beer Game's simplistic costs calculations. We chose this method for cost calculation since it serves as a means to benchmark against previous studies who have used the same criterion. For further research, a more in depth cost analysis of this model for variance-related costs, such as the production and transportation costs is recommended. When trying to minimise inventory cost, production has to vary according to demand and becomes more expensive. Hence, it becomes more difficult to select appropriate parameter settings. For example, Naim, Wikner, and Grubbström (2007) discovered that increasing the values of T_a and T_i has a negative impact on stock recovery, but a positive impact on production costs. Another point to consider is the fact that inventory holding and backlog costs increase as the product aggregates value. Hence, the backlog and inventory costs at the retailer should be higher than that at the factory.

This work contributes to the understanding of the implications caused by transport capacity on supply chain dynamics research. A practical implication of the research is that production supply chains should carefully manage the planning policies governing the shipment of goods. This work makes clear that if companies plan their shipment provision individually, the capacity required in terms of transportation resource will be higher than the capacity actually needed for the entire supply chain, hence increasing total supply chain costs.

References

- Barrat, Mark. 2004. "Understanding the meaning of collaboration in the supply chain." *Supply Chain Management: An International Journal* 9 (1): 30–42.
- Bicheno, John, Matthias Holweg, and Jens Niessmann. 2001. "Constraint batch sizing in a lean environment." *International Journal of Production Economics* 73 (1): 41–49.
- Burbidge, J. L. 1961. "The new approach to production." *Production Engineer* 40 (12): 769–84.
- Cannella, Salvatore, Elena Ciancimino, and Adolfo Crespo Marquez. 2008. "Capacity constrained supply chains: a simulation study." *International Journal of Simulation and Process Modelling* 4 (2): 139–147.
- Chopra, Sunil, and Peter Meindl. 2007. *Supply Chain Management: Strategy, Planning and Operations*. 3rd ed. New Jersey: Pearson Prentice Hall.
- Datta, Partha Priya, Martin Christopher, and Peter Allen. 2007. "Agent-based modelling of complex production/distribution systems to improve resilience." *International Journal of Logistics: Research and Applications* 10 (3): 187–203.
- de Souza, Robert, Song Zice, and Liu Chaoyang. 2000. "Supply chain dynamics and optimization." *Integrated Manufacturing Systems* 11 (5): 348–364.
- Disney, S. M., M. M. Naim, and D. R. Towill. 2000. "Genetic algorithm optimisation of a class of inventory control systems." *International Journal of Production Economics* 68 (3): 259–278.
- Disney, S. M., A.T. Potter, and B.M. Gardner. 2003. "The impact of vendor managed inventory on transport operations." *Transportation Research Part E: Logistics and Transportation Review* 39 (5): 363–380.
- Disney, S. M., and D. R. Towill. 2003. "Vendor-managed inventory and bullwhip reduction in a two-level supply chain." *International Journal of Operations & Production Management* 23 (6): 625–651.
- Evans, G. N., and M. M. Naim. 1994. "The dynamics of capacity constrained supply chain." *Proceedings of International System Dynamics Conference, Stirling, Scotland* 28–39.
- Forrester, J. W. 1958. "Industrial dynamics: a major breakthrough for decision makers." *Harvard Business Review* 36 (4): 37–66.
- Gavirneni, Srinagesh, Roman Kapuscinski, and Sridhar Tayur. 1999. "Value of Information in Capacitated Supply Chains." *Management Science* 45 (1): 16–24.
- Grubbström, Robert, and Zhiping Wang. 2000. "Introducing capacity limitations into multi-level, multi-stage production-inventory systems applying the input-output: Laplace transform approach." *International Journal of Production Research* 38 (17): 4227–4234.
- Hamdouch, Younes. 2011. "Multi-period supply chain network equilibrium with capacity constraints and purchasing strategies." *Transportation Research Part C: Emerging Technologies* 19 (5): 803 – 820. Freight Transportation and Logistics (selected papers from ODYSSEUS 2009 - the 4th International Workshop on Freight Transportation and Logistics).
- Helo, P. T. 2000. "Dynamic modelling of surge effect and capacity limitation in supply chains." *International Journal of Production Research* 38 (17): 4521–4533.
- Hieber, Ralf, and Ingo Hartel. 2003. "Impacts of SCM order strategies evaluated by simulation-based 'Beer Game' approach: The model, concept, and initial experience." *Production Planning and Control* 14 (2): 122–134.
- Holweg, M., and J. Bicheno. 2000. "The reverse amplification effect in supply chains." *Global Logistics for the New Millennium 5th International Symposium on Logistics* 1215 July, Tokyo, Japan: 549–554.
- Hong-Minh, S. M., S. M. Disney, and M. M. Naim. 2000. "The dynamics of emergency transshipment supply chains." *International Journal of Physical Distribution and Logistics Management* 30 (9): 788–815.
- Hosoda, Takamichi, and Stephen M. Disney. 2006. "The governing dynamics of supply chains: The impact of altruistic behaviour." *Optimal Control Applications to Management Sciences* 42 (8): 1301–1309.
- Hosoda, Takamichi, Mohamed M. Naim, Stephen M. Disney, and Andrew Potter. 2008. "Is there a benefit to sharing market sales information? Linking theory and practice." *Computers & Industrial Engineering* 54 (2): 315–326.
- Hung, Wei-Hsi, Chin-Fu Ho, Jau-Jeng Jou, and Yi-Ming Tai. 2011. "Sharing information strate-

- gically in a supply chain: antecedents, content and impact.” *International Journal of Logistics: Research and Applications* 14 (2): 111–133.
- John, S., M. M. Naim, and D.R. Towill. 1994. “Dynamic analysis of a WIP compensated decision support system.” *International Journal of Manufacturing System Design* 1 (4): 283–297.
- Juntunen, Jouni, and Jari Juga. 2009. “Controlling the bullwhip with transport capacity constraints.” *International Journal of Services and Standards* 5 (2): 160–171.
- Lee, H. L., V. Padmanabhan, and S. Whang. 1997a. “The bullwhip effect in supply chains.” *Sloan Management Review* 38 (3): 93–102.
- Lee, Hau L., V. Padmanabhan, and Seungjin Whang. 1997b. “Information Distortion in a Supply Chain: The Bullwhip Effect.” *Management Science* 43 (4): 546–558.
- Mason, Robert, and Chandra Lalwani. 2006. “Transport integration tools for supply chain management.” *International Journal of Logistics: Research and Applications* 9 (1): 57–74.
- Mason, Robert, Chandra Lalwani, and Roger Boughton. 2007. “Combining vertical and horizontal collaboration for transport optimisation.” *Supply Chain Management: An International Journal* 12 (3): 187–199.
- Mason-Jones, Rachel, Mohamed M. Naim, and Denis R. Towill. 1997. “The impact of pipeline control on Supply Chain Dynamics.” *The International Journal of Logistics Management* 8 (2): 47–62.
- McKinnon, A. C. 2006. *Road Transport Optimisation*. 5th ed. London: Kogan Page.
- Naim, Mohamed M., Andrew T. Potter, Robert J. Mason, and Nicola Bateman. 2006. “The role of transport flexibility in logistics provision.” *International Journal of Logistics Management* 17 (3): 297–311.
- Naim, M. M., J. Wikner, and R. W. Grubbström. 2007. “A net present value assessment of make-to-order and make-to-stock manufacturing systems.” *Omega* 35 (5): 524–532.
- Potter, Andrew, and Chandra Lalwani. 2008. “Investigating the impact of demand amplification on freight transport.” *Transportation Research Part E: Logistics and Transportation Review* 44 (5): 835–846.
- Potter, Andrew, Robert Mason, and Chandra Lalwani. 2007. “Analysis of factory gate pricing in the UK grocery supply chain.” *International Journal of Retail & Distribution Management* 35 (10): 821–834.
- Rushton, Alan, Phil Croucher, and Peter Baker. 2006. *The handbook of logistics and distribution management*. 3rd ed. London, UK: Kogan Page Limited.
- Shukla, Vinaya, Mohamed M. Naim, and Ehab A. Yaseen. 2009. “‘Bullwhip’ and ‘backlash’ in supply pipelines.” *International Journal of Production Research* 47 (23): 6477–6497.
- Simatupang, Togar M, and R Sridharan. 2002. “The collaborative supply chain.” *International Journal of Logistics Management* 13 (1): 15–30.
- Simchi-Levi, David, and Yao Zhao. 2003. “The Value of Information Sharing in a Two-Stage Supply Chain with Production Capacity Constraints.” *Naval Research Science* 50 (8): 888–916.
- Spiegler, Virginia L. M., Mohamed M. Naim, and Joakim Wikner. 2012. “A control engineering approach to the assessment of supply chain resilience.” *International Journal of Production Research* 50 (21): 6162–6187.
- Sterman, John D. 1989. “Modelling managerial behaviour: misperceptions of feedback in a dynamic decision making experiment.” *Management Science* 35 (3): 321–339.
- Swaminathan, Jayashankar M., Stephen F. Smith, and Norman M. Sadeh. 1998. “Modeling Supply Chain Dynamics: A Multiagent Approach.” *Decision Sciences* 29 (3): 607–632.
- Taylor, David, and David Brunt. 2001. *Manufacturing operations and supply chain management: the lean approach*. Thomson Learning.
- Towill, D. R. 1997. “Forridge - principles of good material flow.” *Production Planning and Control* 8 (7): 622–632.
- Towill, D. R., M. M. Naim, and J. Wikner. 1992. “Industrial dynamics simulation models in the design of supply chains.” *International Journal of Physical Distribution & Logistics Management* 22 (5): 3–13.
- van der Zee, D. J., and J. G. A. J. van der Vorst. 2005. “A Modeling Framework for Supply Chain Simulation: Opportunities for Improved Decision Making.” *Decision Sciences* 36 (1): 65–95.
- Vlachos, Dimitrios, and George Tagaras. 2001. “An inventory system with two supply modes and

- capacity constraints.” *International Journal of Production Economics* 72 (1): 41–58.
- Wikner, Joakim, Mohamed M. Naim, and Martin Rudberg. 2007. “Exploiting the Order Book for Mass Customized Manufacturing Control Systems With Capacity Limitations.” *IEEE Transactions on Engineering Management* 54 (1): 145–155.
- Wikner, J., D. R. Towill, and M. M. Naim. 1991. “Smoothing supply chain dynamics.” *International Journal of Production Economics*, 22 (1991) 231-248 22 (3): 231–248.
- Wilson, Martha C. 2007. “The impact of transportation disruption on supply chain performance.” *Transportation Research Part E: Logistics and Transportation Review* 43 (4): 295–320.
- Yugang, Yu, Liang Liang, and George Huang. 2006. “Leaderfollower game in vendor-managed inventory system with limited production capacity considering wholesale and retail prices.” *International Journal of Logistics: Research and Applications* 9 (4): 335–350.

Appendix A. Equations for modelling the supply chain

Place Table A1 here!

Table A1. Difference equations used for simulating the Beer Game and Initial Settings (IS)

Description	Difference equation	IS
Level of the supply chain Time period	$J=1, 2, 3$ and 4 for retailer, wholesaler, distributor and factory, respectively t , in weeks	NA
Consumption	$CONS(t) = \begin{cases} 4, & \text{if } t \leq 4 \\ 8, & \text{if } t > 4 \end{cases}$	(A1.1) 4
Incoming order	$INORDER_J(t) = \begin{cases} CONS(t), & \text{when } J = 1 \\ ORATE_{J-1}(t), & \text{when } J = 2, 3 \text{ and } 4 \end{cases}$	(A1.2) NA
Shipment received	$INSHIP_J(t) = \begin{cases} SHIP_{J+1}(t - Tp_J), & \text{when } J = 1, 2 \text{ and } 3 \\ ORATE_J(t - Tp_J), & \text{when } J = 4 \end{cases}$	(A1.3) 4
Maximum shipping	$MAXSHIP_J(t) = AINV_J(t - 1) + INSHIP_J(t)$	(A1.4) NA
Desired shipping	$DSHIP_J(t) = BACKLOG_J(t - 1) + INORDER_J(t)$	(A1.5) NA
Shipment	$SHIP_J(t) = \min[DSHIP_J(t), MAXSHIP_J(t)]$	(A1.6) 4
Actual inventory	$AINV_J(t) = AINV_J(t - 1) + INSHIP_J(t) - SHIP_J(t)$	(A1.7) 12
Backlog	$BACKLOG_J(t) = BACKLOG_J(t - 1) + INORDER_J(t) - SHIP_J(t)$	(A1.8) 0
Average consumption	$AVCON_J(t) = AVCON_J(t - 1) + \frac{1}{1+T_{a,J}}(INORDER_J(t) - AVCON_J(t - 1))$	(A1.9) 4
Desired work in process	$DWIP_J(t) = T_{p_J} \times AVCON_J(t)$	(A1.10) NA
Work in process	$WIP_J(t) = \begin{cases} \sum_{i=1}^{T_{p_J}-1} SHIP_{J+1}(t - T_{p_J} - i) + ORATE_J(t) + BACKLOG_{J+1}(t - 1), & \text{when } J = 1, 2 \text{ and } 3 \\ \sum_{i=1}^{T_{p_J}} ORATE_J(t - T_{p_J} - i), & \text{when } J = 4 \end{cases}$	(A1.11) 12
Error in work in process	$EWIP_J(t) = DWIP_J(t) - WIP_J(t)$	(A1.13) NA
Desired inventory	$DINV_J(t) = 12$	(A1.14) 12
Error in inventory	$EINV_J(t) = DINV_J(t) - AINV_J(t) + BACKLOG_J(t)$	(A1.15) NA
Order rate	$ORATE_J(t) = \max[0, AVCON_J(t - 1) + \frac{EINV_J(t-1)}{T_{i,J}} + \frac{EWIP_J(t-1)}{T_{w,J}}]$	(A1.16) NA

Appendix B. Algorithm for capacitating the supply chain

Algorithm 3 Vertical Collaboration - VC_u

```

1: for  $t = 1$  to 250 do
2:    $j = 4$  ▷ Starting with upstream echelon
3:    $C_{SC}(t) = \text{constant}$ 
4:   while  $j > 0$  do
5:     if  $\text{Min}[DSHIP_j(t); MAXSHIP_j(t)] < C_{SC}(t)$  then
6:        $SHIP_j(t) = \text{Min}[DSHIP_j(t); MAXSHIP_j(t)]$ 
7:     else
8:        $SHIP_j(t) = C_{SC}(t)$ 
9:     end if
10:     $C_{SC}(t) = C_{SC}(t) - SHIP_j(t)$  ▷ Remaining capacity
11:     $j = j - 1$  ▷ Moving to previous echelon and repeating
12:  end while
13: end for

```
