

**Narratives of Postcolonialism in Liminal Space:
The place called Phoenix Park**

**Kate Moles
School of Social Sciences
Cardiff University
2007**

UMI Number: U584926

All rights reserved

INFORMATION TO ALL USERS

The quality of this reproduction is dependent upon the quality of the copy submitted.

In the unlikely event that the author did not send a complete manuscript and there are missing pages, these will be noted. Also, if material had to be removed, a note will indicate the deletion.



UMI U584926

Published by ProQuest LLC 2013. Copyright in the Dissertation held by the Author.
Microform Edition © ProQuest LLC.

All rights reserved. This work is protected against
unauthorized copying under Title 17, United States Code.



ProQuest LLC
789 East Eisenhower Parkway
P.O. Box 1346
Ann Arbor, MI 48106-1346

Abstract

Encounters with physical places construct a sense of both communal and individual identity. This thesis looks at the effects of transformation and fragmentation of existing and remembered places through a qualitative engagement with postcolonial Ireland in the context of modernisation. Phoenix Park, Dublin, is taken as the lens, constituting the research site and refracting both historical legacy and contemporary (re)invention. It is argued that many of the ‘monuments’ of contemporary and historic ‘Irishness’; events, gatherings, buildings, statues, structures and spaces, are represented in the Phoenix Park, Dublin and as such the space acts as an important location for the development of shared memories and commemoration, and understandings of state, culture, nature and history. The Park creates an illusion of nature, designed from scratch and then re-presented back to human audiences in a cultural performance. Using ideas from postcolonial thinking (Bhabha, 1994; Spivak, 1990, 1999), this thesis asks what this performance tells us about the culture of the Park and the way people understand it.

Colonialism is inherently spatial; processes of mapping, charting and defining space are linked with the colonial project, as are the epistemological issues connected to these methods. This thesis examines these ideas by looking at a *postcolonial* space; by examining the changing uses and events that have occurred in the Park. The thesis works through the intersections between the local and the national; in a liminal place that exists in the interstices of history, culture, space and nature. By exploring the cracks in these discourses, it discovers new epistemologies, cultures and understandings in Phoenix Park. The three main themes that emerge from this research surround ideas of authenticity, nationalism and Irishness and the engagement with and understanding of space and place through a postcolonial perspective.

Acknowledgements

The thanks and gratitude I wish to express are not best served by the neat list of names that these acknowledgements can accommodate. Over the past four years I have received help and support in a myriad of forms and it has made me particularly happy that many people who began as academic acquaintances have been transformed into close friends.

There are, however, a number of people who deserve particular recognition and thanks. Ian Welsh has lead me with his wisdom, driven me with his courage, and motivated me with his passion. I will miss our supervisions, where I always come out full of ideas and imagination. Susan Baker has reeled in my flights of fancy, and monitored my claim making in a tireless attempt to produce something that makes sense. Yin and yang, they have allowed me to develop theoretically and academically in the years I have worked with them, and I am very lucky to have had such outstanding supervisors.

This research would not have been possible without the help, support and time of the staff in the Phoenix Park, Dublin. Their enthusiasm to participate and willingness to engage with the issues under discussion was beyond expectation. In particular I would like to mention Jim and Moira Manning and John McCullen.

Within Cardiff University, Joanna Latimer and Bella Dicks provided me with ongoing advice and support; Claire Connolly offered direction and an Irish ear; and, without whom I most definitely would not have made it this far, Liz Renton told me what to do and when I needed to do it by.

Doing a PhD is often regarded as a lonely experience, but thanks to the following people, solitude was not something I ever had to endure. Their support and enthusiasm for distraction is greatly appreciated. Thanks Alex, Cat, Katie Jones, Lil Dude, Merryn, Kate, Karen Chalk, Rich, David, Mark and Ali.

Thank you to all my family for their support and confidence in me.

Patata, you've made me so very happy – and I'm so glad that you came into my life... Thank you for the past three years, and for everything else.

This research was made possible by the financial support from the Economic and Social Research Council, Cardiff University and the British Association of Irish Studies.

Narratives of Postcolonialism in Liminal Space: The place called Phoenix Park

Table of Contents

	Page Number
Declarations	i
Abstract	ii
Acknowledgements	iii
Table of Contents	iv
List of Tables and Pictures	vii
List of Appendices	viii
Chapter One	Introduction
1. Entering the Fifth Province	1
2. Theoretical Positioning	5
3. The Structure	5
Chapter Two	Postcolonialism and Ireland: Firing the Canon
1. Introduction	9
2. Ireland: Postcolonial?	10
2.1 Political Arguments	13
3. DissemiNation: Emigration and the Irish	15
4. Irish Studies and the ‘Critical Orthodoxy’	19
4.1 Field Day	22
4.2 Critical Orthodoxy and Marginalisation	24
5. Nationalism and the Nation	26
5.1 The Myth of the Nation	28
5.2 Fanon and National Consciousness	33
5.3 The Problems of Nationalism	40
6. Spivak and the Subaltern	43
7. Bhabha and Nationalist Representations	45
8. Conclusion: Sociology and Postcolonialism	49
Chapter Three	Mapping the Liminal
1. Introduction	54
2. Section One – The Liminal	55
2.1 The Postcolonial Lineage	55
2.2 The Anthropological Lineage	60
2.3 Theorists on the Margin	64
3. Section Two – Land and Identity	67
3.1 Place, Space and Identity: Mapping the Terrain	67
3.2 Landscape and Colonialism: Mapping the Colonised	68
3.3 An exercise in Colonialism: Mapping Ireland	70
3.4 Down to Earth	73
4. A Third Space?	73

5. Conclusion: Space, Identity and the Liminal	78
--	----

Chapter Four Methods: In Media Res

1. Introduction	81
2. Meaning in Media Res	82
2.1 In Media Res: Subjective Selves	84
2.2 Reflexivity: Negotiating Selfhood	88
3. Postcolonialism and Anthropology	90
3.1 Where do we go from here?	95
4. Methods Used	97
4.1 Interviews	98
4.2 Active Interviewing	100
4.3 Questionnaires	101
4.4 Analysis	102
5. Vignettes around methods: Traversing Theory and Praxis	103
5.1 Access	104
5.2 Interviewing the Head Guide	106
5.3 Interviewing the Office of Public Works: Personnel in the Park	106
5.4 Meeting the Residents	108
5.5 Interviewing the Visitors	109
6. Conclusion	110

Chapter Five Walk in the Park

1. Introduction	111
2. Stepping into History	113
3. Naming and Opening the Park	116
4. The Phoenix Park Act 1925 and the Office of Public Works (OPW)	124
5. Áras an Uachtaráin and other ‘symbols’ in the Park	128
6. Monuments in the Park	132
7. A Life in the Day of the Park	133
8. Conclusion	138

**Chapter Six Authenticity, Modernity and
Postcolonialism**

1. Introduction	140
2. Postcolonialism and State Affects	141
3. Park Management	144
4. Positioning the Park in a Past, Present and Future Dublin	145
5. The Architecture of the Second City of the Empire – Georgian Dublin	147
6. Links across the Empire	155
7. Managing the History of the Park	158
8. Reconstructing the Authentic	163
9. Packaging the Authentic	167
10. Conclusion	172

Chapter Seven	Ideas of Irishness and Mass Events	
1. Introduction		174
2. Ireland and Irishness in the Park		174
3. Events in the Park		176
3.1 The Park as a Stage		177
4. The Phoenix Park Murders		178
5. Religious Mass Events		185
6. The Pope’s Visit		186
7. An Other side to the Park		192
8. Music and Football – Bastions of Irish modernity?		194
9. Conclusion – Changes in Function and Identity		196
Chapter Eight	The Visitor Centre	
1. Introduction		200
2. The Building		201
3. Telling Tales – Presenting the Irish		204
4. Into the Centre		206
5. The Film: A portal into the Parks history		206
6. On Displays		209
7. Reception Area		210
8. ‘The Park through the Ages’ – Downstairs		211
9. Observing the Displays		214
10. Upstairs		219
11. Conclusion – Leaving the Centre		221
Chapter Nine	Consumers	
1. Introduction		223
2. The Popular Park		226
3. A Personal, Magic Place		229
3.1 A Natural Place		231
3.2 A Social Place		232
4. The Irish Park		234
5. The Changing Park – Transformations and Transitions		239
6. The Future Park		246
7. Conclusion		250
Chapter Ten	Conclusion	
1. Positioning the Thesis: Introducing the Conclusion		252
2. Main Themes		256
2.1 Authenticity		256
2.2 Nationalism and Irishness		261
2.3 Space and Place		265
2.4 Liminality and Thirdspace: A thirdspace of enunciation		269
3. Conclusion – Postcolonialism and Sociology		271

Afterthought	273
Bibliography	274
Appendices	290

List of Tables and Pictures

List of Tables

	Page Number
Table 1.1 The Fighting Irish	18

List of Pictures

Picture 4.1	Extracts from <i>In Media Res</i> , by David Lilburn	87
5.1	The Phoenix Monument	119
5.2	The Position of the roundabout on Chesterfield Avenue	135
5.3	The Seating Area	135
6.1	Provosts House, TCD	149
6.2	Merrion Square	149
6.3	Sean Heuston in Phoenix Park	154
6.4	The Earl of Carlisle Plinth	155
6.5	The 'Indian Wars' by Joseph Kirk	156
6.6	The Peoples Flower Gardens	159
6.7	Knockmaree Burial Mound	161
6.8	One of the types of lamp post in the Park	170
6.9	Lamp with Phoenix Park sign	170
6.10	Display in the Park about the lamps	171
7.1	The Visitor Centre display on 'Murder in the Park'	179
7.2	The cross cut into the ground	181
7.3	Cross cut into ground, with Áras an Uachtarain opposite	182
7.4	Cross with people and stairs leading up to it	187
7.5	Pope in 'Pope Mobile' in Phoenix Park	187
7.6	The Visitor Centre display	188
7.7	Some of the original plans	189
7.8	The writing under the cross	190
8.1	Aerial view of the Visitor Centre, Restaurant and Castle	201
8.2	The restaurant	205
8.3	The Entrance to the Visitor Centre	205
8.4	The door into the Visitor Centre	206
8.5	Exhibition Space in the Phoenix Park Visitor Centre	209
8.6	Significant Dates Poster	210
8.7	The display melds real and imagined	212
8.8	Clay figures 'observing' the display	215
8.9	Reproductions of Knockmaree Cist, in the Visitor Centre	215
8.10	Pope's Chair, Cannon and '40 Elms'	216
8.11	The architecture is intended to blur inside and outside	219
8.12	Model of the Park	220
9.1	Photographs of the Rangers in the 1930s	240

List of Appendices

Appendix One	Ordnance Survey Map of the Park	290
Appendix Two	Visitors Map of the Park	292
Appendix Three	Architects Drawings of the Visitor Centre	294
Appendix Four	Residents Letter	299
	Residents Questionnaire	300



Chapter One: Introduction

‘The fifth province is not anywhere here or there, north or south, east or west. It is a place within each of us – that place which is open to the other, that swinging door which allows us to venture out and others to venture in ... tradition has it that the fifth province acted as a second centre, a necessary balance’

Mary Robinson, Inauguration speech as President of Ireland, December 3, 1990

1. Entering the Fifth Province

The complex interplay of memory, identity, place and history is used in this thesis to examine ideas of Irish identity and postcolonial theory, and the application of each within a sociological imagination. Phoenix Park was selected as a research site on the grounds that it embodies significant historical, spatial, social and cultural meanings of Irishness. Its location on a margin twixt urban and rural reinforces its centrality as one of the key sites within which and upon which the meaning of Irishness has been actively constructed and portrayed through time. Spatially and figuratively Phoenix Park spans urban and rural, colonial and postcolonial, culture and nature, constituting a range of meanings which are reconfigured from a range of standpoints through a variety of forms of consumption.

This thesis presents narratives around the history, culture and nature of the Park that alternatively disrupt, problematise and reinforce the history that is presented in the Visitor Centre, written and oral histories of the Park and the management’s plans and objectives for its conservation. Stories and narratives help constitute different realities; they smooth over things to present a clear picture while performing certain political, social and cultural tasks. The different tasks that the different narratives perform and the ways in which they have become accepted and used constitute a starting point of the thesis, and through the empirical work alternative realities and narratives are presented so that by the Conclusion a collage of information about Phoenix Park has emerged.

In the quote above, Mary Robinson, Ireland's first female president, describes the old Celtic symbol of the fifth province as a space of openness, acceptance and diversity. This space exists beyond, and as an addition to, the four provinces of Ireland; acting as a place where imagination can extend and restraints dissolve. It is a place where questions can be asked, answers sought and where history, community, self and other converge to form new pathways of existence and compromise. This fifth province offers a position from which to approach issues surrounding Irish identity, contemporary Irish society and understandings associated with each. Phoenix Park, in Dublin has become a fifth province for this work, allowing the interrogation of issues surrounding postcolonialism, history and identity.

Memories of physical places construct a sense of both communal and individual identity, and this thesis looks at the effects of transformation and fragmentation of existing and remembered places through processes of modernisation, globalisation and, primarily, colonisation. Where are the new sites of shared memories and commemoration which bring people together? Where are the new 'monuments' which help to navigate the modern self? It is argued in this thesis that many of these 'monuments' of 'Irishness'; events, gatherings, buildings, statues, structures and spaces, are found in Phoenix Park, and as such the space acts as an important location for the development of shared memories and commemoration.

The Park creates an illusion of nature, developed from scratch and then re-presented back to human audiences in a cultural performance. Using ideas from postcolonial thinking, this thesis will ask what this performance tells us about the culture of the Park and the way people understand it through their engagement with the cultural and natural components of the Park, and the place they form when they converge. Urban public parks are an intrinsic feature of most towns and cities and exist as the one of the largest synthetic, chiefly aesthetic objects in existence. Their origins lie in a complex of historical, social, economic and political factors that revolve around the problematic of the perceived dangers and consequences of rapid industrialisation and urbanisation in the 19th century, or in the case of Phoenix Park, as outlying country estates that have been opened to

the public for benevolent reasons. This research is a case study of the origins, development and use of Phoenix Park, Dublin, as an historical legacy, writ large on the landscape of the city. Public parks can be understood as a material manifestation of the diversity of discourses involved in their production, as well as examples of ‘social spaces of distraction and display’ (Zieleniec, 2006) that are important in understanding the modern city. Contemporary social analysis increasingly involves a consideration of space as a fundamental factor. The complexity involved in theorising multilayered, multi-functional social spaces such as public parks requires a conceptual framework that is historically and culturally sensitive to the economic, social and political discourses, functions and meanings underlying their production as part of the social sphere in which they exist.

The Park exists as a synthetic natural site, created and represented back to society. The antagonistic relationship between nature and society/ culture is an underlying theme of this thesis as the arguments found in this debate develop and are developed through postcolonial enquiry. Nature exists as the ‘other’, on the margins of society and the social. The history of this position of nature further needs to account for how colonialism and racial oppression have also been premised upon a separate nature which is there to be exploited by and for the ‘West’. Thus, nature has been seen to consist both of separate, ‘virgin’ territories of often extraordinary natural abundance, and of people who are seen as more ‘natural’ as workers or diminutives and later as objects of the colonising gaze (Arnold, 1996; Grove, 1990; McClintock, 1995). These ‘natural’ presumptions aligned to different groups, whether they have different skin colours to the colonisers, or are simply regarded as being less advanced (the ‘ape-like Irish’ that are found in early accounts of the country, Curtis, 1997), position those people in a certain place, and it is difficult to get out from it. As Macnaghten and Urry state,

‘To be defined as ‘nature’...is to be defined as passive, as non-agent and non-subject, as the ‘environment’ or invisible background conditions against which the ‘foreground’ achievements of reason or culture...take place. It is to be defined as ... a resource empty of its own purposes or meanings and hence available to be annexed for the purposes of those supposedly identified with reason or intellect.’
(Macnaghten and Urry, 1996: 15)

Nature is socially, historically and geographically located, and the colonisation of this nature, along with the society it is being located in has wide ranging ramifications for the way the space is understood. The positioning of nature as the 'other' to society means that it is located outside of 'normal' understandings of the social, though this has been dramatically addressed in more recent environmental sociology. The introduction of ideas of postcolonialism adds a double 'othering' in this moment, a postcolonial natural space has been doubly 'othered' through the colonisation of the nature and the colonisation of the society it is located in and through.

To conduct meaningful research on action and interaction in a spatial setting it is important to first establish exactly what conceptualisations of space will be utilised and proposed, and this is addressed in Chapter 3. We need to understand the complexities of incorporating subjectivity, materiality and various cultural and discursive notions and values in contemporary society. In this way, space is a triadic construct in the sense that it is a creation, a site of production and a site to be experienced and consumed. The Park is a constructed landscape, shaped by sets of agents that are caught up in a web of social, cultural and political circumstances. Every landscape is a synthesis of culture and context, a text which may be read to reveal the force of dominant ideas and prevailing practices, as well as the idiosyncrasies of a particular author (Ley and Duncan, 1993). In Phoenix Park, the Management propose and make prevalent a dominant discourse that involves certain assumptions about history, identity and place but there are many other discourses that help constitute the Park. As Cosgrove (1984: 269) argues, 'landscape is a social and cultural product, a way of seeing projected onto the land', and there are a number of ways of seeing and understanding the place that is Phoenix Park. Following Relph, it is taken as a starting point that,

'landscape is not merely an aesthetic background to life, rather it is a setting that both expresses and conditions cultural attitudes and activities...landscapes are therefore always imbued with meanings that come from how and why we know them.'

(Relph, 1976: 122)

The different ways of knowing Phoenix Park stem from personal experience of the space, historical understanding of the different events that have occurred in the Park and communal use and interaction with the place. These different tenets come together to form a unique site that allows the interrogation of postcolonial identity, liminality and hybridity.

2. Theoretical Positioning

Theoretically, this thesis moves towards inter-disciplinary inquiry; it draws from a wide range of theoretical sources that include sociology, cultural studies, cultural geography and anthropology. These are used to inform the position that is reached, and are drawn on at appropriate times through the thesis. This approach has been adopted in order to uncover the different aspects of Phoenix Park by using the theory most applicable to them; however, it is a sociological inquiry and recourse to the ‘sociological imagination’ (Mills, 1967) is made as a way of uncovering the empirical application of postcolonial theory. The theoretical position adopted through this thesis emerges as a result of the substantive work, though conforms widely to ideas of poststructuralism, which are inherent in postcolonial theory. This position informs the methodology adopted and the gaze used to look at the Park.

3. The Structure

The opening three chapters present the theoretical foundations underpinning the thesis. Chapter 2, *Postcolonialism and Ireland: Firing the Canon*, presents ideas associated with postcolonial theory and Irish Studies, examining what is commonly regarded as the ‘critical orthodoxy’ and the way it is aligned with postcolonial theory that relates to Ireland and other areas. In this chapter the main postcolonial theorists are presented; Said, Fanon, Bhabha, Spivak, and their work is related to themes that are present in the substantive work. This chapter concludes by reflecting on the union between sociology and postcolonial theory, a body of work that has been predominantly focused on more literary application. This theme continues through the thesis, and is revisited in the Conclusion.

Chapter 3, *Mapping the Liminal*, examines the main theme that emerged from the empirical research; the idea of liminality and the liminal. The idea of the

liminal is evoked to understand the Park, and the postcolonial and anthropological lineage of the term is discussed, culminating in a section on theorists who employ the idea of liminality or marginality in their work, both culturally and spatially. This chapter then moves onto a more grounded discussion of mapping, and the way this process influences ideas of place, landscape and people. This discussion reinforces the social constructedness of land and place. Having highlighted the importance of place and liminality, the chapter moves on to the idea of thirdspace (Bhabha, 1994; Soja, 1996) arguing that there needs to be a cultural and epistemological realignment of the sociological imagination to incorporate previously marginalised and subaltern accounts and theoretical positions. The conclusion brings together the linked strands of space, identity and liminality.

Chapter 4, *Methods: In Media Res* presents the methodological considerations and related theory. Theory is presented as method in this chapter; this framework draws heavily on the previous two chapters, developing ideas of subjectivity and reflexivity in the process. The chapter includes a section on the historical legacy of anthropology, and the problems this presents to contemporary ethnography and qualitative enquiry as developed through recourse to postcolonial theory. The problems of representation, authority and legitimacy are discussed in relation to practical methodological concerns.

Chapter 5, *A Walk in the Park* is the first of five substantive chapters; the data gathered during the participant observation stage of the research is presented here. This chapter offers a positioning piece; an introduction to the cultural and natural landscape of the Park. It presents the history of the Park and the important 'monuments' and buildings found throughout the space. There is a short piece on the Office of Public Works, the management arm of the Park, and its role through history. This chapter provides the background needed to conceptualise and contextualise the following four chapters. The chapter is structured as a walk around the Park, and while presenting the history of the Park that is crucial for understanding the following chapters, like a walk it aims to bring some of the interaction with nature, the connections that are forged through

walking around the space and the nuances that textual description often overlooks.

Chapter 6, Authenticity, Modernity and Postcolonialism, engages with one of the main thematic areas of the thesis. The idea of authenticity underpins this chapter, and this is related to ideas of state, management and architecture. The idea of the authentic is extended beyond the Park and traced through Dublin, as the second city of the Empire, and as a site of fighting during the 1916 Rising and War of Independence. The history of the Park discussed in this chapter is problematised, and the underlying claims and truth stakes are examined with recourse to the idea of the 'authentic'. The authentic is recognised as a constructed origin; a way of making legitimacy claims that are ideological and negotiated. The linked themes of history and authenticity are examined using different accounts about the Park and historical links, and the choice of period for selection as the 'authentic' historical Park is deconstructed.

Chapter 7, Ideas of Irishness and Mass Events, focuses on the different uses the Park has seen through its history, and the way these events can be seen to mirror and construct important shifts in concepts of Irishness and Ireland. This chapter also draws attention to the processes of inclusion and exclusion found through the Park, specifically during illicit night-time activities, which are juxtaposed with more celebrated, communal activities. This chapter presents details about the most celebrated of the Parks events, the Pope's 1979 visit, and more infamous events, and relates them to the society in which they occurred, as well as contemporary attitudes and ideas concerning them are presented and discussed. This is used to develop an idea of different ideas of Irishness, and the problems with presenting a unified, singular national identity.

Chapter 8, The Visitor Centre, draws the themes from the previous two chapters and brings them together spatially, within the Visitor Centre. This centre provides an articulation of the ideas held by different groups in the Park and management, and the chapter presents points of antagonism that allow us to see more clearly the everyday sense making arrangements that exist. It also presents the different displays within the Park, placing them within the context of the

wider history of the Park and cultural understanding of the position it holds. The Visitor Centre brings the idea of liminality to the fore, not only architecturally but also through the different arguments pertaining to the construction of various displays in the centre.

Chapter 9, Consumers, engages with the people who visit, live in and consume the Park, and presents an account from a different perspective than the more 'official' discourses that are found through the other four empirical chapters. This chapter uses more personal accounts of the Park, and examines the way the transformations and transitions that it has undergone has impinged on people's view and understanding of the space. This chapter looks to the future of the Park and asks how this will unfold; using this as a metaphor for the future of Ireland and ideas of Irishness. Many of the events discussed in Chapter 7 are revisited using a different perspective in this chapter, developing the collage of information around the Park.

The Conclusion draws on the three main themes of authenticity, nationalism and Irishness, and space and place; using liminality and thirdspace to underpin the discussion. Through the presentation of these themes, the conclusion recounts the main ideas of the thesis, and the way it has added to existing knowledge on sociological understandings of space and place, processes of postcolonialism and ideas of locality and community. The conclusion looks at the links that have been developed between postcolonialism and sociology, and what each approach can glean from the other.

The thesis ends with an Afterthought, which includes a reflection on what could have been conducted differently in the course of the research and what has been learnt.



Chapter Two: Postcolonialism and Ireland – Firing the Canon

1. Introduction

This chapter presents the different approaches to understanding Phoenix Park that are found in the thesis. It is a literature review that spans a wide range of literatures, drawing from literary studies, history, social commentaries, political science and sociological texts. Primarily, the chapter will engage with the body of work called Irish Studies, developing the ideas found within it using postcolonial and sociological understandings. The chapter begins by looking at the idea of Irish Studies itself, setting up questions that will be answered through the engagement with the literature and then the empirical work in Chapters 6, 7, 8 and 9. Following this, the issue of postcolonialism and its relationship to Ireland is developed, unpacking the different tenets of postcolonialism that apply to the Irish case, and raising issues around why it may not apply. Using ideas found in postcolonial theory and applying them to one of the main themes in Irish Studies, the chapter will then move to the idea of emigration, and the Irish abroad. Theoretically the chapter will then move into the area of Irish Studies more purposefully and look at the different groups that constitute this body of Irish Studies, and the different issues they privilege in their work. The chapter expands to encompass more international thinking around these areas to include the work of postcolonial theorists Fanon, Said, Spivak and Bhabha. In concluding, this chapter begins to piece together these different approaches and literatures with a sociological method; the thesis draws widely on different approaches, but underpinning it all is a sociological imagination.

The term ‘Irish Studies’ requires a multileveled reading, unpacking what it means to different people and groups concerned with its production and consumption. Can it be simply classified as a study of Ireland, and of the people of Ireland, being extended to include some kind of concept of ‘Irishness’ and

aimed at developing a model of what that might mean? Or is it exclusively coupled with a grand postcolonial reading of Irish culture? Who are the Irish that are included? And what time frame must these definitions incorporate? The starting point of this piece of work is to investigate these questions, providing a critical appraisal of the direction Irish Studies has taken in the last two decades.

This chapter will offer the signposts needed to navigate the theoretical issues which will be found through this thesis. The subheading of the chapter is 'Firing the Canon', because while there is a tendency to try and bring everything under the heading of 'Irish Studies' or 'Postcolonialism' it is also an important aspect of both these disciplines to avoid the grand narratives of modernity and recognise the fragmented, local narratives which exist. This theoretical position encounters problems, problems found throughout the postcolonial literature, as the body of work advocates a move beyond the univocal perspective of modernity and, inherently, colonialism, and endeavours to recognise the many voices and multiple interpretations that are ever present. A fundamental aspect of postcolonialism is challenging the practise of speaking and writing by which dominant discourses come into being and understanding the spatiality of power and knowledge. Power and knowledge are woven through this thesis, and have obvious relations to Foucault (1984). While they are not dealt with explicitly in this chapter they are ever-present through the Said literature which underpins the understanding of the postcolonial employed throughout the thesis. Colonialism is all about power, and knowledge underpins the practise, without these dual forces and the discourses produced through and around them the understandings of colonialism and subsequently postcolonialism adopted here are weak. These issues arise again in the Chapter 3 which looks at place and space, and Chapter 4 on methods.

2. Ireland: Postcolonial?

The first issue that needs to be addressed is the identification of Ireland as postcolonial, and consequently its legitimate historical reading as a colony. There are a number of 'objections' to this claim, each of which will be dealt with in this section, but also in a more implicit manner throughout this whole thesis. It is important not to appear bound by 'either-or-terms' (Leerssen, 1998: 45), and

the choices up for discussion do not end at Ireland either being a product of centuries of colonial rule under which the Irish were repressed and abused, or that Ireland was never a colony at all. This section will rehearse some of the arguments addressing if it would be wrong to interpret Ireland as postcolonial, and through these debates will address the reasons for regarding Ireland as postcolonial.

The geographical position of Ireland has been problematic for some when describing Ireland as postcolonial. Positioned on the edge of Europe, though assigned more symbolic and political centrality than the countries of 'Eastern Europe', Ireland has identified with the strategies and ideas of the European Union far more than the neighbouring UK. It is this location that poses the first problem. Can Ireland be understood by comparing it to other Western European societies, especially the smaller, peripheral countries dominated by more powerful neighbours, such as Norway, rather than through a comparison with colonised societies in far off places, such as India or Australia? In geographical, racial, cultural, and economic terms, according to this argument, Ireland was always part of Western Europe, and it is important to recognise the importance of the immediate environs on the development and culture of a nation. It should also be mentioned here that much of Europe has, at one time or another, been subject to imperial rule (Hapsburg, Ottoman, English, French, and briefly, Italian and Spanish Fascism and German Nazism). According to this argument, Ireland can be understood most aptly through its comparison with other Western European countries, which provides the appropriate framework for analysis. Following this view, the position of Ireland as the Saidian 'Other' (1978) of postcolonial discourse is undermined, as Ireland is an integrated part of a Europe.

This position can be problematised in two ways. First, in terms of spatial location, it is crucial to the assertion of Ireland as postcolonial that the belief that Ireland was a colony of Britain does not rest on the idea that the country was outside or 'Other' to Europe and was hence not part of a European, Western spatial position. Edna Longley argues that intellectuals who employ a postcolonial perspective 'deny Ireland's European past because of the Republic's European present, in a materialist EU, casts doubts on the victim-position to

which Irish Nationalism has always appealed' (Longley, 1997: 30). It is apparent that the major cultural and political revolutions that have shaped European society - the Reformation and Counter-Reformation, the Enlightenment, French republicanism and German romanticism, for example, have also been highly influential in Ireland. However, to understand Ireland as having been a colony does not deny these processes; what it does do is contend that these wider European currents were mediated through a society which was 'in its structural composition – class and ethnic relations, land tenure systems, relations with England and so on – objectively colonial in character' (Cleary, 2003: 23). So while Ireland belonged to the same geo-cultural locale, the 'same orbit of capital' (Cleary, 2003: 24), as the major European colonial powers, it is integrated into that orbit in a very different way. The contention that Western Europe provides the only appropriate comparative framework for the evaluation of Irish society assumes an essentially homologous relationship between the country's spatial location, its socio-economic composition and its culture.

This understanding leads to the emergence of lines of thinking which focus on the conceptual couplet of 'backwardness' and 'advanced'. Postcolonial thinking (Bhabha, 1994; Said, 1978; Spivak, 1987; Young, 1990, 1995) overrides this notion, and attempts instead a position which recognises the influencing European developments, while at the same time recognising the specific factors in Ireland relating to its constitution as a colony. By understanding that the influence of important events such as the Enlightenment are mediated by the economic and political relations that are integral to colonialism, as well as the important social structures that emerge as a result of the relationship, the way knowledge is assumed and used in colonial Ireland must be understood within this complex web of postcolonialism.

This position does not endorse the 'intermediate solutions' which emerge in theoretical writing about Ireland (Carroll, 2003: 25). These approaches aim to amalgamate the positions above and conceive of Ireland as an anomalous or atypical case of colonial experience, which requires that it should not be read alongside other colonial experiences. In the same vein, it has been suggested that Ireland is a case of 'internal colonialism' (cf. Hechter, 1975) whereby society is

replicated through specific class structures which reproduce the colonial through internal relationships that are based on political and economic inequalities between regions within a single society. In the case of Ireland, it is suggested that these relationships are formed around religion, language and class; these factors exclude certain people from prestigious social and political positions. This assigns a uniquely 'Irish experience' to the colonial encounter by proposing that these relations are found only in the Irish case. This rests on the assumption that there is a 'standard' colonial experience, and that Ireland does not tick the right boxes to qualify. By imposing ideas of standardisation across cultural arenas, it means that things which do not fit into this framework don't exist in it. The second standpoint, which the internal colonialism argument fails to recognise, is that the cultural colonisation which is referred to in internal colonisation is an intrinsic part of the colonial process.

For Cleary, the question of whether Ireland could be considered a colony exists on two 'analytically discrete' levels that 'require different methods of investigation' (Cleary, 2003: 26). He believes that 'one has to do essentially with the matters of consciousness, systems of representations, and discursive regimes' and 'the other with "objective" structural and socio-cultural correspondence' (Cleary, 2003: 26). This differentiation is informative, though ultimately insubstantive, as the relationship between these two levels requires perhaps the most interrogation, and will be developed throughout this research. The interplay between discursive structures and socio-cultural correspondence is paramount to the understanding of the important aspects of postcolonial theory. To position two discrete positions with no interplay between the two fails to recognise the complexity involved, and instead the liminality of the postcolonial must be appreciated not only on a spatial, social or economic level but also on a theoretical level, as this thesis develops in Chapter 3.

2.1 Political Arguments

The political stem of the argument that claims Ireland was not a colony, and should therefore not be regarded as postcolonial, can again be understood on a number of levels. Historically, the Act of Union of 1801 provides the main legislative basis of the argument. The Prime Minister William Pitt and the Irish

Chief Secretary Lord Castlereagh wrote this Act in an effort to quell the religious fighting in Ireland and to 'unite' the country with Britain under one parliament. Ireland's existing parliament was dissolved and Ireland became a sub-state of the United Kingdom ruled directly from Westminster. The policy was unpopular with the members of the Irish Parliament who had spent large sums of money purchasing their seats. Castlereagh appealed to the Catholic majority and made it clear that after the Act of Union the government would grant them legal equality with the Protestant minority. To appease the unhappy Protestant ruling class, the government paid compensation to the borough proprietors and promised pensions, official posts and titles to members of the Irish Parliament, and the Act of Union was passed in 1801. However, emancipation for the Catholics was never realised, and it disappeared from the political sphere entirely as King George III disagreed with Pitt's stance and went to Henry Addington to convince him to become Prime Minister. On hearing this, Pitt resigned as Prime Minister, and so the promise of Catholic emancipation faded away. What followed were turbulent times in Ireland, and in 1823 Daniel O'Connell, Richard Lalor Sheill and Sir Thomas Wyse formed the Catholic Association. This organisation campaigned for the repeal of the Act of Union, Catholic Emancipation, and the end of the Irish tithe system (a system of heavy taxes), universal suffrage and a secret ballot for parliamentary elections. The Catholic Association grew rapidly and in 1829 Sir Robert Peel, the Duke of Wellington and other leading members of the government began arguing for reform.

The theoretical haziness found in historical writing on Ireland and its postcolonial claim converges at this point, with many people dispelling the colonial model. As Ruane observes,

'[w]hen historians deal with this post-Union period, a colonial conception of Irish history is commonly displaced...in favour of a modernisation perspective that attributes little significance to colonialism. For many historians...the Union seems to put a remarkably speedy end (apparently by the magic wand of parliamentary statute) to whatever colonial features may have existed in Irish society over previous centuries.'

(Ruane, 1992 in Cleary, 2003: 25)

Cleary (2003) suggests the historians adopt the approach outlined above by Ruane because they do not want to recuperate a nationalist metanarrative

remonstrating ‘about 700 years of oppression’ or adopting the victim position in their own history. In fact, this stance is problematic on many levels. The parliamentary union, while providing political integration in an abstract sort of a way, did little else. Economic practices between the two countries continued along the established colonial lines that they had before. The persistence of this long established and deeply entrenched colonial system, combined with the ruthlessness of the free market economy and the blight on the potato crops were the major factors which resulted in the Great Famine of the mid 1800s. The lack of effective relief provided by the ruling landlords and stronger farmers, who were part of a colonial ruling class, meant that the poorer peasantry faced evictions and hardship which resulted in the death and mass emigration of great numbers of Irish.

3. DissemiNation: Emigration and the Irish

People leaving the shores of Ireland for distant lands were not a unique occurrence confined to the years following the Famine. The Irish have populated every land that promised new hope or fertile soil. The rhetoric which supports the idea that someday the Irish diaspora, the ‘greater Ireland overseas’, will unite again and return ‘home’ is often seen as representative of the hospitality that the Irish are famed for. Indeed, Mary Robinson’s Presidency featured an eternal flame of welcome burning outside her official residence in Phoenix Park to express the idea of welcoming, and to act as a symbolic beacon for Irish to return to. The flame has been sustained, extending this gesture across another presidency. However, for Declan Kiberd (1995: 579), this rhetoric of hospitality is derived from traditionalist, revivalist nationalism in its aim of uniting the ‘ravaged nation’ once again. The positions offered here demonstrate the different perspectives and approaches to emigration and the ‘returnee’ in Ireland today. To understand contemporary Ireland it is important to examine the patterns of emigration and the social and cultural (re)actions aligned with it.

Ireland has always been a good example of what Bhabha (1994) has called a dissemiNation, a nation constructed through a people that extend far beyond the land and through the ideas and notions possessed by these absentees. The thread of emigration runs through Irish history, starting from the ancient tradition of

travelling scholars, to the emigration of the Great Famine to the economic emigration of the nineteenth and twentieth centuries. Indeed, the end of the Gaelic ancestry was marked by the Flight of the Earls, when Hugh O'Neill, 2nd Earl of Tyrone, and Rory O'Donnell, 1st Earl of Tyrconnell left Ireland with ninety of their followers in 1607. Though they had been treated leniently by the English government of Ireland following their defeat in 1601 and rebellion in 1603, in 1605 the new Lord Deputy of Ireland, Arthur Chichester began to restrict their freedoms and fearing arrest, they fled.

This history of emigration has contributed greatly to the idea of the nation of Ireland. Furthermore, as Said points out 'all nationalisms develop from a condition of estrangement' (2000: 178) due to the need for differentiation and singularity. This emigrant's 'backward look', might be a universal phenomena as Salman Rushdie argues, a fantasy driven by a lack of connectedness and belonging,

'exiles and emigrants or expatriates, are haunted by some sense of loss, some urge to reclaim, to look back, even at the risk of being mutated into pillars of salt...[W]e will not be capable of reclaiming precisely the thing that was lost;...we will, in short, create fictions, not actual cities or villages, but invisible ones, imaginary homelands.'

(Rushdie, 1992: 10)

It is easy to find examples of this relating to Ireland, from films that represent Ireland with a backwards-looking nostalgia such as John Ford's *The Quiet Man* and David Lean's *Ryan's Daughter* to adverts about Irish products which appear on British television such as Caffreys beer. In this advert, with a drink from the cup of this magical Irish ale (itself a mythical concept) a man is transported from the bar in New York to the 'imaginary homeland' where red-haired colleens and wild horses take centre stage in this expression of rural Ireland. Representations like this are reinforced in adverts which appear on Irish television. The person who is 'away' is seen as reminiscing about 'home' and the people and places that they miss. This is most commonly a spatial representation, the green of home; the rural is the expression of Ireland through these representations, the localness of Ireland and Irish culture and the peacefulness associated with the countryside.

These representations of the Irish green idyllic mean that the rural holds a particular position in Irish reconstructions. This next section looks at this specifically, examining how the rural has held such an important place in a country that is struggling with issues of modernity and tradition. W.B. Yeats's novel *John Sherman* (1891) represents a key moment in the construction of fantasy Ireland through the Literary Revival, and works through a series of classic tropes of the Irish nationalist migrant imaginary. Sherman is the eponymous Anglo-Irishman in London, contrasting the River Thames with the river which flows through his hometown of Ballah. Whilst the former symbolizes (cultural) pollution and the threat of his life being swept off course (the 'filthy modern tide of modernity'), the latter conjures up the nourishment and security of his idealised home (Arrowsmith, 2003: 104). Yeats fantasises about an Ireland with 'rural innocence' standing in contrast to the capitalist brutality of England. This positioning of the rural in representations of Ireland, in contrast to the developed, forwardly progressing capitalist England and UK, makes it an important part of this thesis. The choice of Phoenix Park as a research site is embedded in ideas of land whilst also occupying a position that exists outside mundane day-to-day life. It offers a point of intersection between escape from the everyday, by being outside the city, and representations of inclusion and belonging, through the institutions and activities which form its culture. It is this contradiction intrinsic in the idea of nation which can be found throughout ideas of postcolonialism, the idea of inclusion and exclusion and imaginary and real. The sites of research will express these tensions and investigate their expressions through representations of nationhood.

The fact that Irish people such as the Protestant Ascendancy, Scots Irish, and the Catholic Irish have taken part in the colonisation around the globe poses problems for the classification of Ireland as postcolonial to certain groups. While some Irish were taken into slavery in the Caribbean in the seventeenth century (Carroll, 2003: 4), others became slave owners and settlers both there and in North Africa. Additionally, the Irish were, and continue to be, a part of the British army, with many joining up as both soldiers and officers. It began when King Edward I recruited Irish light cavalry to serve in his English Army in France in the Hundred Year War and to patrol the English border with Scotland

and continues to contemporary times with recognition by the Irish state of the Irishmen who fought in World War I and World War II.

The Irish were present, fighting for the colonial power which controlled them in every battle, as elsewhere. This is part of the liminality of the colonial encounter; the space that the colonised, as with the coloniser, inhabits is not reducible to a simple equation. It is important to resist dichotomies and recognise complexities and overlaps that occur within history, to recognise the fractured, fragmented past.

Table 1.1 – The Fighting Irish

1243	Irish fought for the Plantagenets against the Welsh.
1485	Irish fought the Yorkists against the Lancastrians in the War of the Roses
1520	Irish troops fought in the Netherlands
1587-96	Irish served as Sir E. Stanley's Irish Regiment with the Protestant Dutch against the Catholic Spanish. He later switched sides and took the Irish with him.
1597-1604	Irish became known as El Tercio Irlanda, later becoming the Independent Irish Companies.
1605-1628	Spanish raised their own Irish regiment under Prince Henry O'Neill, son of Hugh O'Neill, The O'Neill and Earl of Tyrone.
1625	During the English Civil Wars the Stuart Kings hired a large Irish Army to fight Cromwell in England and Scotland and the bulk of the British Army was Irish when the Stuarts were driven to exile in France.
1707	British had six Irish Regiments.
1713	Irish Regiments fell to two, but then increased to five again.
1860	Two-thirds of British Army were Irish or of Irish descent.
WWI	A quarter of a million Irish died in British uniforms in the three Irish Divisions (10 th , 16 th and 36 th Divisions).
WWII	38 th Irish Brigade was formed.

This section is used to illustrate that while the Irish colonial experience is not straightforward; in fact colonialism itself is never straightforward. The

experience of the colonised is mediated by different forces, different relationships and different cultural and historical encounters. This means that for many of the problems with classifying Ireland as postcolonial, in fact the problem lies with the understanding of postcolonialism that is being employed. In the next section the dominant understanding of postcolonialism is examined and positioned within a discipline of 'Irish Studies'.

4. Irish Studies and the 'Critical Orthodoxy'

The issues surrounding whether Ireland is postcolonial have been looked at in the above section, but the best way to examine Ireland's 'right' to be called postcolonial is to look at the body of work called Irish Studies, and the internal debates that have occurred around this issue. Before that it is pertinent to pause and think about the political implications for the description of Ireland as postcolonial, as it is an important issue within Irish Studies, and specifically the work of Field Day, which will be discussed below. The continuing situation in Northern Ireland is a constant reminder that the discussions and theoretical debates are far from removed from the society Irish Studies discusses.

Irish Studies emerged in response to the failure of the legitimating narrative of modernising bourgeois or statist nationalism in the Republic at the end of the 1960s (McCarthy, 2000). At the same time, the 'modernisation' policies of Terence O'Neill in Northern Ireland proved incapable of resolving the contradictions that had been unleashed, which were encroaching on sectarian privilege (Cairns and Richards, 1988: 141-2). Modernisation in Ireland had proved itself incapable of dealing with what Raymond Williams called 'residual' and emergent ideologies and social formations (Williams, 1981). The resultant cracks in previously hegemonic cultures, demonstrate that the narratives which had been held as true were now being blown wide open. The resultant crisis was expressed as a failure of criticism, as the historian John Wilson Foster suggested,

'The critical condition of Ireland at the present time seems undivorceable from the condition of criticism in Ireland. The failure of Irish society is the failure of criticism'

(Foster, 1991: 215)

The Republic's reaction to the violence in the North was to close borders to critical discourses, Marxist and neo-Marxist theories of economics, dependency and culture, the ideas that were emerging with the newly developed area of cultural studies that would have helped to explain the crisis. The failure of intellectuals (in the Gramscian meaning) to propose an oppositional discourse, a critical counter-narrative to the hegemonic ones, has for McCarthy (2000) contributed to the violence of Northern Ireland after 1969, because instead of there being open debate and discussion, there was a refusal to talk or to question. However, the work of Field Day and the area of Irish Studies emerged as a 'critical orthodoxy' out of this political context, and have been shaped and constructed by this.

Irish Studies has come to be affiliated with an identifiable group of literary critics primarily associated with the Field Day agenda and position on postcolonial criticism. The Field Day writings propose a 'grand narrative' (Connolly, 2004: 140) that would encompass Irish history, culture, society and identity in their writings; the underlying conviction which holds the Field Day Company together is that in Ireland a new discourse is needed for a new relationship between their idea of human subject and their idea of human communities (Deane, 1990). This is exemplified in their use of the concept of Fifth Province, which has been discussed in the Introduction and is used in the discussion of Bhabha's Third Space of Enunciation below. This group merged in Derry in 1980, brought together by the playwright Brian Friel and the actor Stephen Rea for the hugely acclaimed play *Translations*. This initial focus on the medium of theatre was to expand dramatically, in line with the specific interests of each of the directors, a group of playwrights, poets and actors, Seamus Deane, Seamus Heaney, and Tom Paulin, which resulted in their most ambitious project, *The Field Day Anthology of Irish Writing* (1991). Field Day is discussed more comprehensively in the section below.

Translations emerged through dialogue between Friel and J.H. Andrews, a distinguished historian of Irish cartography (Connolly, 2003). Andrews produced a history of the first Ordnance Survey in Ireland in 1975, and it was on this that Friel gained his interest and knowledge of the process. The themes found in this

play concerned the replacement of Irish language place names with English counterparts during the first British Ordnance Survey and the metaphorical issues concerned with mapping and landscape, people and place. These themes marked the direction which the Field Day Company wished to explore. The issues raised by this play, which focused on Nineteenth Century cultural and social issues, were thread through subsequent work and the anachronistic knowledge displayed in the play of the political future informs the postcolonial stance. Friel was aware that this play communicated powerful messages about contemporary Irish society; he commented that he could see no harm in ‘the tiny bruises’ that his play ‘inflicted on history’ (Friel, 1983: 123). This link between place and sense of self, and the issues associated with both, makes the play an important part of postcolonial theorising in Ireland and marks the symbolic beginnings of thinking about Ireland and Irish history through this lens.

One of the directors of Field Day, Seamus Deane, reads the play as confronting the problem of language in terms of a dual critique of modernity and tradition (Deane, 2003). His seminal essay *Dumbness and Eloquence* (2003) holds *Translations* as encapsulating the main themes he discusses, ‘[i]t poses the question of language loss and acquisition in the light of a modernity that is founded on expertise and violence, and of a traditionalism that is founded on fidelity and anachronistic pedantry’ (Deane, 2003: 120). In this way the importance of dumbness and eloquence pertaining to language and culture is rehearsed. Change, the cornerstone of modernity, is not embraced by the central, Irish speaking characters, and their methods of learning are unable to adapt and therefore must be transmogrified. Deane uses these arguments to call for a return to Irish language, and a continuation in the efflorescence that has come from a sense of emancipation from the coercive forces that once killed the language. To become eloquent in the language that we believe we once had is he believes the ‘language of freedom’ (Deane, 2003: 122). For Said, *Translations*,

‘... immediately calls forth many echoes and parallels in an Indian, Algerian, or Palestinian reader and spectator, for whom the silencing of their voices, the renaming of places and replacement of languages by the imperial outsider, the creation of colonial maps and divisions also implied the attempted reshaping of societies, the imposition of foreign languages and systems of education, and the creation of new elites, that become familiar obstacles to be overcome by the

independence or liberation of anti-colonial movements that sprang forth, each in its own way trying to provide itself with alternative histories, languages, and political self-creations'

(Said, 2003: 178)

The cartography in the play is a theme echoed in other Irish works. Eavan Boland published a poem in 1994 called '*That the Science of Cartography is Limited*', which puts forward a strongly negative view of the science and rationality of maps, and 'presents a set of oppositions that serve to align the map with colonial authority and not with those oppressed by it, with surface rather than depth, and with inert official codes, not movement or flux' (Connolly, 2003: 31). In a similar vein, the cartography practices in *Translations* are seen as oppressive and alien, a set of codes being imposed on a nation in a forceful and epistemologically aggressive manner.

The mapping that occurs in the play ties together the themes of place and identity, as the older Irish names hold meaning beyond their words and through the translation to English the places become unrecognisable to even those that live there. This process is coercive but not violent, as the people in the play want to adapt and understand the language, and processes which are occurring. The dissident voices are Irish, and can therefore be understood as inferior in the processes of translation that are going on. This important relationship between land, identity and mapping will be discussed in Chapter 3.

4.1 Field Day

In addition to plays, Field Day published a number of pamphlets and full-length texts. Under the board of directors these publications moved the area of Irish Studies, and the now associated postcolonial narrative, in new directions. The highly ambitious and exceptionally encompassing *Field Day Anthology of Irish Writing* (1991) and the publications associated with it propelled postcolonial theory to the centre of Irish debate and generated a distinct network of 'postcolonial' intellectuals. This collection received much criticism since, as an anthology, it was defined as much by what was left out as that which was left in. Much of this criticism was focused on the Field Day as a collective, imagining that the often contradictory voices to be found in the anthology reflected a deep

felt antagonism within the group, and a break down of understanding of some over-riding theory. However, far from speaking in a homogenous voice when a member speaks for the group they are actually offering their own specific interpretation of Field Day, rather than giving voice to some underlying and communal ethos, which informs the group as a whole. Realising this reveals much more about the individual directors and, subsequently, sheds more light on Field Day, than an indiscriminate coalescing of these highly disparate persons could ever achieve. Of course, it is true to say that there is something that can be seen as linking the various members of the board together, and that is to be found in their adoption of the postcolonial paradigm in their analyses of Irish culture.

The internationally celebrated theorists Said, Jameson and Eagleton, through a pamphlet commissioned in 1988 and reissued in 1990 as one volume, extended this network beyond the shores of Ireland. This, along with the Anthology, marked the symbolic beginnings of this canon which continues to hold centre stage in Irish Studies. In the aftermath of the Field Day pamphlets, additional volumes advanced this agenda further, and progressively postcolonial criticism was conflated with 'Irish Studies'.

The 1988 book by Cairns and Richards, *Writing Ireland: Colonialism, Nationalism and Culture*, which was the first extended historical survey of Irish literature to draw explicitly on the wider international body of postcolonial criticism inspired by Said's *Orientalism*, and the publications of Boylan and Foley (1992), Lloyd (1993, 1999), Kiberd (1995) and Eagleton (1995) among others (Connolly, 2004: 140) consolidated Irish postcolonial studies as a distinct and comprehensive paradigm. The edited book by Clare Connolly *Theorising Ireland* (2003) defines this paradigm, including works from all the significant authors and encompassing the postcolonial view most representatively. This book is situated in the symbolic centre of what Connolly has called elsewhere the 'critical orthodoxy' (2001: 301) of Irish Studies, that is the postcolonial focus inspired initially and continued by many of the authors of the Field Day company. This 'dominant framework' (Connolly, 2004: 139) has acquired an accepted definition and general understanding and has become the leading voice on all things Irish, within the area of Irish Studies. This framework is

theoretically informed by the postcolonial writings of Bhabha, Said, Young and Spivak, and brings Irish theory into a similar arena as postcolonial thought globally.

Seamus Deane (1983), writing in relation to the situation in Northern Ireland, calls for a 'dissolution of that mystique' which is found in the writings of Yeats and Joyce. These writers represent for him 'hot' and 'cold' rhetorics, twin poles indicating the stances that inform Irish literary study, whilst standing at loggerheads to each other. The Romantic stance that Yeats represents is juxtaposed to the forward-looking cosmopolitanism of Joyce (Connolly, 2001). And it is these two mindsets, these two ways of looking at the past, that the new theoretical turn in Irish Studies has set to problematise. Instead of being bound to the modernist, rejection of all things historic in the heroic quest for progress, or being trapped in the past with a Romantic, tradition orientated view; Field Day has offered a new alternative. The myth that modernity held the only means of escaping the past was refuted, and the ideological tenets of this stance became starkly visible. The turn to postcolonial theory facilitated the problems that were emerging around the linked concepts of modernity and progress. A return to the past was advocated, but not in the manner of the nationalist or revisionist historians, rather a return to the past that allowed the future to develop, but also recognised the need to move beyond a history of administrations and rulers (Connolly, 2001), and into the history of the people themselves. Rejecting the revisionist view that there is nothing worth 'salvaging' from the Gaelic past of Ireland, there is a push to reconnect Ireland's present to its past, a move which marks a shift from anti-essentialism to the strategic essentialism of Spivak as discussed below. Within this view, cultural memory is of paramount importance because of the power it holds in developing identity.

4.2 Critical Orthodoxy and Marginalisation

Through the acceptance of Field Day as the dominant discourse, there has been a tendency for the marginalisation of other forms of enquiry into Ireland and related issues. The formation of postcolonialism as a 'critical orthodoxy' (Connolly, 2004: 139) is usually separated from other perspectives in Irish Studies, such as Irish historical studies and women's studies. The growth of

interest in Ireland as a site of research and study marked an increase in academic and journalistic writing about cultural studies in Ireland. Cultural Studies became an umbrella term under which the disciplines of literature, history, anthropology, music, dance and sociology co-existed, though they resisted any form of interdisciplinary interaction. This compartmentalisation was confounded by the dominance held by literary studies and history, a tendency continued in the Irish Studies discussed above, to the point of systematic neglect of areas such as popular culture and sociological enquiry. By the time this literary corpus had achieved sufficient status, overturning the position previously held by the historians, it provided a counter-position to the longstanding hegemony of history and historians in the previous twenty years.

While this thesis adopts and accepts many tenets of the Field Day version of Irish Studies, it is necessary at this point to note that, of course, there is a discourse which exists beyond the boundaries of the paradigm. There are a number of critical overviews of Field Day/ 'Irish Studies' and the postcolonial theory which is associated with it. There are alternative readings of a postcolonial Ireland emerging around this centre. Additionally, despite its conjecture, postcolonial criticism is not a total paradigm that synchronises the entire agenda of Irish Studies and its intellectuals. Likewise, Irish criticism is not completely synonymous with postcolonialism. Irish critics do not form a homogenously orientated field, and there are many who have not embraced postcolonial theory as formulated within the Field Day writing and associated polemics. The writer and poet, Edna Longley had produced many of her theoretical articles as an articulate polemicist of the Field Day Company and specifically Seamus Deane. She stands diametrically opposed to Deane, representing the other side to the theoretical coin; her stance with regard the overlap between literature and politics is expressed in her essay 'Poetry and Politics in Northern Ireland' where she makes her most famous statement, 'poetry and politics, like church and state, should be separate' (1986: 185). She goes on to give us a number of demarcated fields – poetry, politics, church, state, and criticism and warns against intersections between these fields. 'Poetry is conceived of as a Platonic ideal, which it is the mission of criticism to rescue and protect, most especially from "politics" and "ideology"' (quoted in McCarthy, 2000: 204).

Where poetry and politics do intersect, for Longley the result is bad politics and bad poetry. However, to hold this stance in Ireland is problematic. Returning to her first statement, while it is true that church and state *should* be separate they are not, so the point is undermined considerably. Additionally, because of the nature of her methods of analyses which are closely aligned with the text and nothing else, it means that she has no regard for the context of the production or consumption of it. The problems with this stance will become apparent as this chapter unfolds. Longley has criticised the Field Day writers, and especially the work of Declan Kiberd, Luke Gibbons, Seamus Deane and David Lloyd, for holding a critical version of Irish nationalism. In fact, postcolonialism was originally intended to cut across several binaries, most especially colonialism and nationalism, or revisionist and nationalist readings of history.

5. Nationalism and the Nation

Longley accused Field Day of holding a nationalist stance, while they class themselves as postcolonial. Often there are difficult overlaps between these two positions, that appear to be the same until particular issues come to the fore and the illusion is dispelled. However, it is impossible to engage with ideas of postcolonialism without reference to ideas of nationalism, and as such this section will examine the ideas underpinning it. A discussion of nationalism requires an enquiry into what is actually meant by the term. It is important to distinguish between nation and nation-state, and in turn, the differences between disparate types of nationalism. If by nation we mean a self-conscious community with a common sense of history and a literature of its own, as well as claims to political identity and territorial sovereignty (Hastings, 1997: 3) then Ireland, like many other postcolonial nations, existed for much of its history as a nation without a nation-state. For Adrian Hastings (1997), nationalism in Ireland emerged as early as the late sixteenth and early seventeenth century, as a result of the Enlightenment.

The idea of identity as linked with the nation and nationalism, as discussed by Finkelkraut (1988) and Calhoun (1997), traces the rise of identity to the appearance of cultural nationalism in the Eighteenth Century. Herder first pioneered this idea, in 1774, with the mythical and backward looking *Volkgeist*.

Developing Montesquieu's thesis, Herder presented the view that all nations 'whether the most exalted or humblest, possess a way of life which is unique to them and irreplaceable' (Finkielkraut, 1988: 12). While it was not until Jena, and Napoleon's victory, that this idea was embraced by Herder's own people the Germans as a way of compensating for the military defeat by embracing the idea of a collective identity and culture, the Romantic Movement took up these ideas much earlier. German Romantics and French Conservatives were eager to dispel the Napoleonic dictatorship and the terror after the revolution as consequences of Enlightenment ideas that favoured progress and reason over tradition and emotion and substituted the idea of a nation based on social hierarchy determined by birth and a monarchy chosen by divine right with the image of a free and voluntary association linked together in the terms of a contract. Returning to Ireland, it is important to understand the extent to which romantic ideas have influenced the development of Irish nationalism. According to this stance, the political division of the once unified island is an offence against the natural order and the people's point of origin, and undermines the right to be together as a nation bound by spirit (*geist*), language and history.

This tradition has surfaced periodically along Ireland's timeline, encapsulating the view of the romantics that Ireland is a nation in and of herself. We can see the convergence of nationalism and politics with the development of The Gaelic Society of Ireland in 1807, which employed 'historical evidence' to substantiate claims of English cruelty, as well as to support the Irish peoples 'natural ancestry' to the Celts, thus providing historical backing to their 'natural' claim to the island. Evidence was used to support the claim that language, religion and history bound the Irish in a common identity, thus 'illustrating' that they were the sole, rightful inhabitants of Ireland. The basic argument of The Gaelic League was that 'Ireland must stop being a mere "province" of England and become instead an independent nation through its restoration of its ancient Gaelic traditions and language' (Kearney, 2001). Revivalism played an important part in the debate around Irish identity as inaugurated by Hyde, Pearse and Yeats, who were exponents of the cultural revival, which endorsed the idea that the Irish identity was integral to cultural nationalism. The Ireland proposed in the writing

of Yeats is one where there is almost a mythical goodness about the land, and a true sense of Irishness to be found there.

5.1 The Myth of the Nation

However, this idea that the nation is a natural form, something that exists in the 'natural order' is a fallacy. As Gellner (1983: 49) says, '[n]ations are not inscribed into the nature of things'. So the nation is an ideology, an 'imagined political community' (Anderson, 1983: 6), imagined because the 'members of even the smallest nation will never know most of their fellow-members, meet them, or even hear of them, yet in the minds of each lives the image of their communion' (Anderson, 1983: 6). Similarly, Brennan points out that the nation refers 'both to the modern nation-state and to something more ancient and nebulous – the "*natio*" a local community, domicile, family, condition of belonging' (Brennan, 1990: 45). So, central to the idea of the nation are notions of collectivity and belonging, a mutual sense of community that a group of individuals imagines it shares. This sense of mutual community is manufactured by the performance of various narratives, rituals and symbols which stimulate an individual's sense of being a member of a group.

As Eric Hobsbawm (1983) has argued, the nation depends upon the invention of national traditions which are made manifest through the repetition of specific symbols and icons. The performance of national traditions keeps in place an important sense of continuity between the nations present and past, and helps concoct the unique sense of the shared history and common origins of its people. Nations often traffic in highly revered symbols that help forge a sense of its particular, idiosyncratic identity in which the nation's people emotionally invest. The emergence of national symbols such as the flag or the national anthem are part of the 'invention of the nation', the repeated performances of rituals, events or symbols which take on an emotive and semi-sacred character for the people. Think of how the public burning of the nation's flag as a form of protest is often a highly provocative act, and can trigger emotive responses. Such idiosyncratic and emotive symbols serve as focal points around which a large number of people can gather as a single, national body.

Alongside this invention of tradition is an equally important narration of history. Nations are underwritten by a reference to a common history, a story that unites the collective people and explains the origins, individual character and traits that go along with the national identity. Postmodern theory problematises the idea of one 'true' history, and in affect there are many different histories and many more ways of reading them, but the idea of a national history proposes and endorses one reading, and in some cases makes this the only history acceptable and worthy for study. It is this that the revisionist historians in Ireland were rebelling against, and they were eager to dispel the idea that one standpoint could be given a privilege position with which to discuss history. In reality, however, by arguing against one stance they were simply proposing an alternative, and their aim to dissolve the privileged voice of nationalist history failed due to their ardent defence of their own voice.

Highlighted by Said (1994) as one of the unifying incidents in colonised nations, the loss of the Irish language is often held as a devastating occurrence. Following the Famine times, the move away from Irish was so strong that often parents who spoke Irish were unable to communicate with their children who grew up speaking English. English was seen as the language of progress and modernity. For Anderson (1983), a defining feature of the nation is the standardisation of one unitary language that all of the members can understand. In Ireland today, this language is undoubtedly English.

The Norse settlements (AD 800 onwards) and the Anglo-Norman colonisation (AD 1169 onwards) introduced periods of new language diversity into Ireland, but Irish remained dominant and other speech communities were gradually assimilated. In the early sixteenth century, almost all of the population was Irish-speaking. The main towns, however, prescribed English for the formal conduct of administrative and legal business. The events of the later sixteenth century and of the seventeenth century for the first time undermined the status of Irish as a major language. The Tudor and Stuart conquests and plantations (1534-1610), the Cromwellian settlement (1654), and the Williamite war (1689-91) followed by the enactment of the Penal Laws (1695), had the cumulative effect of eliminating the Irish-speaking ruling classes and of destroying their Irish cultural

institutions. A new ruling class, or Ascendancy, whose language was English replaced them and thereafter English was the sole language of government and public institutions. Irish continued as the language of the greater part of the rural population and, for a time, of the servant classes in towns. From the middle of the eighteenth century, as the Penal Laws were relaxed and a greater social and economic Irish mobility became possible for the native Irish, the most prosperous of the Irish-speaking community began to conform to the prevailing middle-class ethos by adopting English. Irish thus began to be associated with poverty and economic deprivation. This tendency increased after the Act of Union in 1801.

So, why did the Irish choose to learn English in Ireland? Many explanations have been given: to prepare their children for likely emigration; to master the language of modern commerce; to do well at school; the threat of punishment at school¹. One of the great paradoxes of nineteenth-century history is that English became the language of Irish separatism, the medium in which the nationalist case was put. If Benedict Anderson is right in saying that print-language creates nationalism then English was the ideal medium through which the bonding of a people into a unified movement could be achieved. Through newspapers, ballad-sheets, handbills and pamphlets, the technology which underpinned nationalism was available in the English rather than the Irish language. Even fluent Irish speakers such as Daniel O'Connell, when they addressed mainly Irish-speaking audiences, chose to speak in the language of London for similar reasons that protesters in Baghdad today hold up placards in English rather than Arabic. Colonialism has always emphasized a line of demarcation between coloniser and colonised; in Ireland, the natives looked like the settlers, so it may have secretly suited the English to have most of the natives Irish-speaking. In that context, the desire of many to learn English might be seen as an anti-colonial mechanism in itself (rather than the act of national apostasy it is seen as in some nationalist circles).

¹ Tallysticks were used in Irish schools, like in Welsh schools, whereby the number of words of Irish used translated into the number of strikes received. Violence and cohesion were employed unsubtly.

The achievement of the people in mastering a new, difficult language with little institutional help has never been sufficiently recognized, even in contemporary Ireland which has failed to reverse that process despite significant state support. It was as if the Irish had moved too far too fast in cultural terms. To give up one language and learn another would perforce become one of the defining experiences of modernity for many people in the twentieth century, but for hundreds of thousands of Irish, it happened a hundred years earlier. Far from being a backward looking people, the Irish have for the past century and a half been one of the more future orientated peoples of the world. To have begun your life in a windswept valley of West Mayo and to have ended it in Hammersmith or Hell's Kitchen was to experience the deracination and reorientation that would for so many millions constitute the central 'progress' of the twentieth century. The Irish were among the first to be caught in a modernizing predicament. If at times they evinced nostalgia for a lost Gaelic past, they did so as the natural human response to being propelled into the future at such speed.

Towards the end of the eighteenth century the Anglo-Irish Ascendancy had begun to develop an academic interest in the Irish language and its literature. Academic interest later merged with a concern for the survival of spoken Irish as its decline became increasingly evident because of the issues outlined above. Language-related activity grew throughout the nineteenth century and, following the establishment in 1893 of the Gaelic League, or *Conradh na Gaeilge*, the objective of maintaining and extending the use of Irish as a vernacular fused with the renewed separatist movement which culminated in the establishment of the Irish Free State in 1922. Today, and since its inception in 1922, Article 8 of the Constitution makes the following affirmation,

- ‘1. The Irish language as the national language is the first official language.
 2. The English language is recognised as a second official language.’
- (Bunreacht na hEireann)

In addition to nations being focused around a common language, there is also a linking historical narrative provided which promotes the unity of time and space (McLeod, 2000). Reverting to Anderson's 'imagined communities'; the issue of a 'standard language' is reinforced in two particular forms of writing. Anderson

argues that the realist novel and the daily newspaper 'provide the technical means for "re-presenting" the *kind* of imagined community that is the nation' (1983: 25). His point in relation to these forms of writing is that the intrinsic assumptions about time and space 're-presented' are duplicated in the ways nations are imagined. With realist novels, there is a group of people whose lives intertwine and there is some relation between all the people, but they do not all meet each other. Despite this, the characters are united by time and space, they are connected by the same 'bounded, fixed landscape within which they simultaneously exist' (McLeod, 2000: 73). Additionally, there is a temporal rule which applies to all the characters in the same way, they are all bound by the same time rules and share a common place and obey the same 'time schema' (McLeod, 2000: 73). In the same way, a daily newspaper replicates these ideas of time and space. Local communities are constructed through tales of occurrence. The act of reading about these occurrences acts as a unifying process through which people can imagine their own position in a larger spatial schema. This occurs through the discussions of news from specific areas in the country and the differentiation that is common between local and foreign affairs, and their position in the temporal schema by the daily occurrence of the news and the facilitation this provides for 'current affairs'. From this, we can see how nations, like the novels and newspapers, are narrated. It is a structure which cements a deep, horizontal comradeship which unites the many into one imagined community through the function of specific forms of narrative.

Bringing Said into this discussion, it is important to recognise that in the construction of this unitary group, there must also be an 'Other'. Through the coming together of one group of people there must also, necessarily, be a group, or in fact infinitely many groups, which are not a part of this group. In their exclusion, this 'other' constitutes what it means to be in the group as much as those who have achieved inclusion. The basis for the exclusion of this group defines those who have been included. This position problematises the ideas of nation as they have been expressed above, and will be discussed further below in relation to the work of Chatterjee, Spivak and Bhabha.

The liberating potential of nationalism for a nation under colonial rule would at first sight appear quite significant. If we accept, for the moment, Anderson's idea of a nation as a community based on silent ties, which unify through ideas of time, space, history and language, then it is easy to see how these feelings provide a valuable resource for anti-colonial struggles. The image of a nation-in-chains provides a solid problem to be fought against, and nationalist ideas and the myth of the nation have provided a liberating force for many countries. Initially, ideas of nation seem inspiring and uniting, but realistically these ideas were more often exclusionary and lead to domination of groups of people or areas which did not support aspects of this vision. In Africa, the constraints of working within a map which had been drawn up by Western powers in the Berlin Conference of 1885 meant that boundaries previously held by the Africans' own 'maps' and traditions were ignored, and tribal identities and land were circumvented for colonial interpretations of the land (de Bliji, 1996).

5.2 Fanon and National Consciousness

During Frantz Fanon's time in Algeria, where in 1953 he was appointed as head of the Blida-Joinville Hospital, he witnessed much of the Algerian struggle for independence against France. Fanon resigned from this post and joined the Algerian struggle becoming one of the leading figures. In his final years he produced his *magnum opus*, *The Wretched of the Earth* (1961). Published by Sartre in the year of Fanon's death at 36 years old, the book was a product of the circumstances that surrounded it. The same year, 1961, preceded the independence of Algeria, achieved after nearly a decade of violent struggle against the French colonial occupation.

Although Fanon wanted to work in Senegal, after his graduation in 1952, he was sent to practise psychiatry at Blida-Joinville, Algeria, which is where the experiences which inform *A Dying Colonialism* (1965) and *The Wretched of the Earth* (1961) occurred. The last third of *The Wretched of the Earth* is devoted to accounts of disorders of the psyche that Fanon worked with, both with the colonisers and the colonised. In privileging the psychic dimension of the relationship he not only challenges what we understand by a political demand but

also transforms the very means by which we recognise and identify human agency.

Fanon develops the Manichaeism perspective implicit in his earlier work *Black Skin, White Masks*. To overcome the binary system of black/ bad and white/ good Fanon argues that to do so would require a 'new world' to emerge. Describing how the 'Manichaeism of the settler produces a Manichaeism of the native' (Fanon, 1961: 73) he illustrates how the evilness of the native exists only in contrast to the evilness of the settler. To move beyond this requires a total revolution, 'absolute violence' (Fanon, 1961: 37), which, drawing on his psychological background, Fanon believed could provide a purifying action, destroying the dual categories of white and black,

'At the level of individuals, violence is a cleansing force it frees the native from his inferiority complex and from his despair and inaction; it makes him fearless and restores his self belief'

(Fanon, 1961: 73)

To move forward, and away from the legacies of colonialism, was to leave behind the classifications which are forged into being at the point of colonisation, and enter a time that attempts to free itself from the 'shackles of the past'. The main point communicated by Fanon in this book is that 'decolonization is always a violent phenomenon'. He views this event as the replacement of a certain type of man by another, through the implementation of a programme of complete disorder which sets out to change the order of the world as mentioned above. The initial violence breaks down the different compartments which the colonised world is broken into, the schools, the quarters, which can be examined and used to reveal the lines of force it implies (Fanon, 1961: 29). To murder is an expression of the natives' collective unconsciousness, to repress this desire means it turns onto the native in a compressed vacuum and devastates them, 'the melancholic Algerian does not commit suicide, he kills' (Fanon, 1961: 241). Fanon on this point highlights the different zones for coloniser and colonised; towns arranged differently both culturally and spatially. The spatial differentiation he discusses is also evident in his election of the rural proletariat class, or *fellaheen*, as the vanguard for the revolution. Upset by the greed and

politicking of the comprador bourgeoisie² in the new African nations, and the manner of their nationalism, which is shared by the urban proletariat, it is the *lumpen-proletariat* in the rural setting who are emblematic of the potential and the outlook for change. The other groups benefit from the economic structure of imperialism, and so cannot move truly and completely away from it as it would lead to their own self-destruction. The ‘embryonic proletariat’ in the towns holds a ‘privileged position’ in the colonised society. In the ‘heat of battle’ all internal barriers do break down, and fall into line with the stand made by the rural masses, ‘that veritable reservoir of a national revolutionary army’ (Fanon, 1961: 2). They emerge because of the nature of development of the country. This group knows the oppression more than the other classes; it has experienced suffering as it relies directly on the land and does not make profit from trade. It also has not been blinded by the false concessions of the colonisers and the empty promises with regard to the economy, as they are never seduced by the promises that they know can never be realised.

The Marxist thought, coupled with the existential belief, aligns Fanon with Sartre, and in fact contextually the two men were concerned with similar philosophical and political themes such as liberation and the discovery of self-identity. Sartre undoubtedly influenced Fanon and the respect was reciprocated through the publication of *The Wretched of the Earth* by Sartre and his writing of the introduction. The existentialist’s claim of the precedence of existence over essence and the negation of a primordial human nature inform the philosophical stance adopted by Fanon. Identity is therefore negotiated and continually evolving as the individual determines. ‘Man’ is in a perpetual state of re-creation, providing a state of freedom that excuses no one from their actions and the consequences that follow. Sartre considers one’s place, body, past, position and fundamental relationship to the ‘Other’ as the facilities of freedom. The influence these ideas hold in Fanon’s work is clear, as is the continued influence they exert over the postcolonial milieu. As such, we can trace these important themes through Fanon to Said and particularly Bhabha, as will become clear as the chapter progresses. It also extends into the Deleuzian ontology of becoming

² This group benefit from the multi-national alliances that otherwise subjugate the people in the country; it demonstrates that global stratification must include national stratification.

(Deleuze, 2004), which emerges as theoretically important in the empirical chapters and contributes the metaphysical debate surrounding identity and difference that is so prevalent in Sartre and Fanon.

To understand the economics of the colonial situation Fanon draws on Marxist thought. In the colonies, the economic base, or substructure as Fanon calls it, is also the superstructure, as the two are co-dependent and synonymous with one or other because of the strength of the links between economic position and the culture, institutions, power structure, roles and rituals. The cause is the consequence in this relationship; colour and position in society and the economic hierarchy cannot be separated. The economic position and relation to the vanguard of the revolution are also linked. Related to this is the way in which the existence of one side of the binary of colour is dependent on the 'Other'; the settler brings the native into existence, which is then perpetuated (this relates strongly to Sartre's 'Other'). This is found on the plane of ethics as well, as the native is declared insensitive to ethics, he represents not only the absence of values, but also the negation of values. He is regarded as the enemy of values, and in this sense he represents absolute evil.

'He is the corrosive element, destroying all that comes near him; he is the deforming element, disfiguring all that has to do with beauty or morality; he is the depository of maleficent powers, the unconscious and irretrievable instrument of blind forces.'

(Fanon, 1961: 32)

All things related to this colonised race, the customs, the traditions, and above all the myths, are the sign of 'poverty of the spirit' and all the negative connotations that the colonisers could think of. But this classification must not remove the coloniser. The colonial context is characterised by the dichotomy that it imposes upon the whole people, and the way in which it positions both sides conversely and contrastingly. Accordingly, it is the quest the native undertakes for his own culture and the process of decolonisation of, not only the land, but of the mind. Fanon examines the role of the intellectual in this process, and he states that in order to assimilate and to experience the oppressor's culture, the native has to leave certain of his intellectual possessions in pawn. Some of the intellectuals condemn the regime as it is based on the domination of the few (Fanon, 1961:

142). However, they do not have the ability to do anything about this, as they have no original thought (and consequently solidarity) because they have unreservedly adopted the thinking of the colonising country, and have become detached from the thought of their own country and people, basing 'its consciousness upon foundations which are typically foreign' (Fanon, 1961: 143). Additionally, this group cannot form their own native bourgeoisie as they lack the necessary capital³.

The colonial situation presents the psyche with previously unknown strains and identity issues, which means that a 'constellation of delirium' mediates the normal social relations of its subjects, 'the Negro enslaved by his inferiority, the white man enslaved by his superiority alike behave in accordance with a neurotic' (Fanon, 1952: 7). Fanon's demand for an explanation emerges from the role adopted by the coloniser in the civil society to civilise and/ or modernise the native, which leads to the emergence of both state and civil institutions which function like caricatures of formally 'fertile institutions' that came before, or, as colonial influence spreads in the society, the colonisers home country. This occurs as the 'native' aims to reproduce this society through the mimicry of the values and desires of the coloniser as opposed to the colonisers' desire, as they maintain the 'otherness' of the country they are colonising. The coming together of the political and the psychic, and the violence discussed above which ensues, coupled with the alienation within identity from ambivalence, compel Fanon to describe the splitting of the colonial space of consciousness and society as marked by 'Manichaeic delirium'.

Fanon's work on the cultural elements of colonisation rest on statements pertaining to national culture, which he links with national consciousness; culture is regarded as the first expression of a nation, the expression of its preferences, of its taboos and of its patterns. During colonialism, this form of culture 'falls away and dies' (Fanon, 1961: 196), leaving the national consciousness fragmented and disjointed as a result. Not only is the nation the condition of culture, it is also a necessity. During the struggle the people gain a (re-)new(ed) culture, which

³ The influx of Foreign Direct Investment resolves and complicates this situation, forming an industrial and entrepreneurial class that resembles the comprador bourgeoisie.

helps forge a new consciousness. After the conflict there is not only the disappearance of colonisation, but also of the colonised mind. This struggle is necessary to overcome the problems of mental disorders that Fanon identifies as part of this colonised psyche, which stems from the fundamentally unanswerable question, 'in reality, who am I?'.

The second section in *The Wretched of the Earth* focuses on national consciousness and, originally given as a speech at the Second Congress of Black Artists and Writers in Rome in 1959, urges writers and intellectuals to forge national consciousness in their work as part of the struggle for independence. This was because Fanon believed that an important part of the struggle for the emergence of a national culture was the 'native intellectual'. This intellectual is a result of the colonial process; they are a group who have been educated or indoctrinated into the colonising nation's way of thinking and intellectual circles.

This is shown in the film *Gandhi*, when the lead character meets the group of young Indian intellectuals, all of who have attended Oxford or Cambridge, and dress in the style of clothing associated with English culture and the institutions at the time. These are held as the greatest thinkers in the nation, and are seen as holding the answers to the difficult questions asked and raised by Gandhi. However there is an obvious problem with the use of these figures. Gandhi, himself an Oxford graduate, understands that it is necessary to dress like the people of India, and live like them, so they may lead themselves and not rely on outside standards or institutions.

This is Fanon's concern, that the native intellectual will revert to the ideals of the middle-class bourgeoisie in the colonising nation, and will ignore or replace the ideas of the indigenous masses. In reaction to this, Fanon believes that these native intellectuals will dismiss the idea that there was no culture in the colonised nation before the colonisers arrived, an idea put forward as a means of justifying colonisation, and instead they try to revert to, and in fact cherish, that which the colonising power dismissed as evidence of barbarism. Speaking about Africa, Fanon dismissed this pan-national focus, emphasising the specific historical circumstances and challenges in each specific colonised location. As such,

Fanon describes three phases that he believes national culture must move through before emerging as a distinct entity. During the first of these, the 'unqualified assimilation' (Fanon, 1961: 179), the native intellectual is inspired by and aims to reproduce the dominant trends in the literature of the colonising power. In the second phase, the intellectual rejects this project, and instead immerses themselves in the cultural history of the people; there is a retrospective vision of what the country is rediscovered, and a championing of all things indigenous. The gaze is historic, and the past is held as superlative. The contemporary focus falls away, and the 'battle' for decolonisation is put on hold, '[y]ou will never make colonialism blush for shame by spreading out little-known cultural treasures under its eyes' (Fanon, 1961: 179–80).

The third phase, or the fighting phase, is the stage which Fanon's call to arms was directed at African literature, with the aim to move this 'forward'. The native intellectual becomes directly involved in the struggle, joining the people and realising, 'it is not enough to try to get back to the people in the past out of which they have already emerged' (Fanon, 1961: 182). Drawing on Marxism, Fanon recognises that during this struggle, during the decolonising process, a new culture will be formed, one which incorporates all the people. The role of the native intellectual is then to reinterpret the traditional culture for these people, to re-present in a way that facilitates the move into the present. Through this modifying process, the artist holds an important role in the fledgling culture, and new, unusual forms of artistic expression emerge in the phase expressing the dynamic and fluid culture out of which they are born (McLeod, 2000: 87). There is a destruction of the old culture, a 'shattering which becomes increasingly fundamental' (Fanon, 1961: 197), and the role of the intellectual in this is to facilitate the change and promote the peoples ideals back to them. The role of culture is of great importance to Fanon in the development of national consciousness.

While Fanon saw hope with nationalism, the Irish case has presented a number of problems to this. The War of Independence showed that nationalism itself would not liberate the people, that there were far more complex social, economic and political forces at play which influenced any move towards ridding the country of

the culture and politics of the colonising presence. The section below looks more at these problems and the issues surrounding nationalism as a concept and practice.

5.3 The Problems of Nationalism

Previously, this chapter has examined the nation as a construct, and the manner in which it relates to colonialisation and decolonisation. This discussion moved on to include ideas of nationalism, seen by some as the vanguard for decolonisation. Nationalism, for Fanon was seen as the alternative to imperialism, the resolving force that would rid the country of unwanted cultural influences and return it to a more honest representation of those who lived within the boundaries. In fact, the advocates of nationalism come against two main problems; the complicity of national liberation movements in Western myth making, and the complications caused by the fact that many occupants of colonial lands did not possess a sense of (to borrow from Benedict Anderson) 'deep, horizontal comradeship' prior to the advent of the colonial government (McLeod, 2000). The idea of a unified, imaginary community is nationalisms greatest strength, but is also its greatest weakness. It provides strength as it allows the people to unify against a common 'enemy', the colonising force. This unifying force allows people to envisage themselves emerging as a free-nation, as embodying all the ideals of the nation discussed above. This vision provides strength, and allows those fighting to have something to fight for, not just in the sense of physical violence but also in the violence of the mind that Fanon discusses; the struggle to rid the mind of the ties of colonialism. However, by forwarding this sense of unity, during the time of turmoil people can embrace their own conceptions of what that means, when the 'nation' they have envisaged and fought for is born, it will be cast in the way that those who gain control have seen.

The Civil War in Ireland, which followed the War of Independence, emerged partially as a result of fighting amongst groups who held alternative ideals of what the nation should be and what the War could and should achieve. For some the realisation of an Irish state represented success, whereas others were driven to produce a socialist state or to ensure that Irish people experienced a better

quality of life than during colonial times. The nation as an idea is necessarily homogenising, as it rests on the idea of the 'other', in that it is defined as much by what it is not as what it is, and therefore aims to present a homogenised version of the people present. As Balibar (1991:46) says, many decolonised nations have undergone the painful experience of 'seeing nationalisms of liberation turning into nationalisms of domination'. King observes,

•
'[w]here the end of the Second World War brought a demand for national political independence to the forefront as a solution to the problems of the colonies, this was soon found to be unrealistic hope as many new nations became divided by civil war and micronationalisms...or failed to develop economically or to offer social justice to those outside the government and its supporters'

(King, 1995: 3)

Partha Chatterjee (1986) problematises the adoption of ideas of nationalism by anti-colonialists to a greater extent and on a more fundamental philosophical level by questioning meaning specific to the idea of nation. The origins of the nation are intimately tied to the pursuit of ideals connected to the Enlightenment. European forms of nationalism are 'part of the same historical process which saw the rise of industrialism and democracy' and 'nationalism represents the attempt to actualise in political terms the universal urge for liberty and progress' (Chatterjee, 1986: 2). Continuing, Chatterjee points out that there is a conflict right at the heart of nationalism which he calls the 'liberal dilemma' which means that while nationalism may promise liberty and universal suffrage, it is complicit in undemocratic forms of government and domination. Progress and civilisation, the main tenants of a discourse of modernity, come to justify and legitimate colonialism in moral terms, through the development of the nation as modern; that is liberal, morally just and interested in the progress of thought and technology. So, in adopting the idea of the nation, with the promise of moral and political freedom and self-determination, as such the anti-colonial nationalist are also adopting this 'liberal dilemma' and are facing the same inherent problems faced by the colonisers themselves. As Chatterjee says,

'Nationalism sought to demonstrate the falsity of the colonial claim that the backward peoples were culturally incapable of ruling themselves in the conditions of the modern world. Nationalism denied the alleged inferiority of the colonised people; it also asserted that a backward nation could 'modernise' itself while retaining its cultural identity. It thus produced a discourse in which,

even as it challenged the colonial claim to political domination, it also accepted the very intellectual premises of 'modernity' on which colonial domination was based.'

(Chatterjee, 1986: 30)

So, as discussed above, not only do the colonisers map out the territories of the colonised, they also map out their thinking in the understanding of nation that is adopted and used.

In this critique of nation and nationalism, as derived from Western colonial practices, there is a homogenised view of the use and purpose of nationalism, and it is over simplistic to reduce the idea of nation as coming from one position, and its adoption as being the same through each nation. In fact, as this chapter moves on to the thinking of Homi K. Bhabha, this view will be interrogated and amended, but it provides a useful starting point for engaging with ideas of nationalism and the nation within a postcolonial understanding. Additionally, Chatterjee draws attention to a crucial issue in postcolonial theory, one adopted in more contemporary writing by Gayatri Chakravorty Spivak, the problematic relations between the elites of the newly formed nation and the masses.

The emergence of dominant voices following the independence of a nation can be viewed on two levels. The first comes from Fanon, who sees that the replacement of the Western colonial ruling class could be by a Western-educated, 'indigenous' ruling class who seem to speak on behalf of the people but essentially keep them disempowered. Second, the tendency of history to identify 'heroes' means that members of the elite are celebrated, whilst the more grass-root, less privileged individuals or groups activities are ignored or subsumed by those of the more visible. This relationship between the visible and invisible subjects of history is a key area of concern for the Subaltern Studies Group, based in India. This group draws on the writings of Marx, Gramsci and Foucault and the members have all examined the ways in which representations of Indian nationalism either ignore the contributions made to anti-colonial struggles by the masses, or explain their activities in such a way that the particular and local forms of 'subaltern consciousness' are not represented adequately. The 'subaltern', a term borrowed from Gramsci, indicates those outside the colonial

elite and the work of Guha (1988) explores the representations of this group, or lack thereof, in the history of Indian nationalism. For him, 'the history of Indian nationalism is thus written up as a sort of spiritual biography of the Indian elite' (Spivak, 1988: 3). Accordingly, Guha (1988) questions these representations and presents them as problematic as they fail to give voice to the subaltern and privilege the voices of the elite. In her seminal essay, '*Can the Subaltern Speak?*' (1988), Spivak brings her theoretical insight to the discussion.

6. Spivak and the Subaltern

Writing primarily about women in the colonised countries, Spivak's attention is focused on the representation of human subjectivity in a variety of contexts. She makes particular reference to the work of the Subaltern Studies group. The focus of this group was on the representation of the subaltern in colonialist texts, and it is to this that Spivak aims her theoretical fire. She begins by turning to the work of Foucault and Deleuze, theorists brought together in their challenge of the notion that human individuals are 'sovereign subjects' with Cartesian autonomous agency over their own consciousness. Spivak, echoing Foucault, believes that human consciousness is constructed discursively. Our subjectivity is constructed through shifting discourses that speak through us, positioning us in particular relations. This decentring of the subject means that our consciousness is always being constructed from positions outside ourselves. Consequently, the individual is not the point of origin for consciousness, and consciousness is not the transparent representation of the self, but is in fact an effect of discourse.

While using the theory of Foucault and Deleuze, Spivak also problematises their positions by examining what she believes is their shared representation of oppressed groups, such as the working class. She states that they fall back into unproblematic discussions of these groups as though they were the sovereign subjects that were rejected above. She argues that these theorists restore the groups to holding a 'centred' consciousness and such they are guilty of a 'clandestine restoration of subjective essentialism' (Spivak, 1988: 74). Importantly, Spivak also draws attention to the position of the intellectual in this process, and the potential for this individual to believe themselves disengaged from the discursive process. While it is tempting to presume that the intellectual

can achieve a sort of transparent medium through which the voices of the oppressed can be represented, a reliable narrator for the lost voices, in fact it is pertinent to note that this is not the case as at no time can the narrator be disengaged from the processes they are embedded in.

Spivak argues that 'giving voice' to the subaltern is problematic as it supposes that the author can 'give' a collective voice to a group who do not have voice in the previous writings. As such this process means that this voice is being imposed onto them. It is also problematic as it imagines that there is a voice which exists outside of discursive construct and can be 'uncovered' through the careful reading of colonialist texts. Representations of subaltern insurgency cannot now be trusted as reliable expressions of sovereign subaltern consciousness, as it is essentially an effect of Western discourse. To retrieve the voice of the subaltern subject from the colonial archives is to risk complicity in an essentialist, specifically Western model of centred subjectivity in which 'concrete experience' is problematically preserved (McLeod, 2000). As Robert Young condenses helpfully, the problem which Spivak identifies is,

'not that the woman cannot speak as such, that no records of the subject-consciousness of women exist, but that she is assigned no position of enunciation [and so] everyone else speaks for her, so that she is rewritten continuously as the object of patriarchy or of imperialism'.

(Young, 1990: 164)

She is always being rewritten with recourse to a form of representation that is incapable of bearing adequate witness to her subject-position.

Reading Spivak can leave the postcolonial theorist in a potentially irresolvable position; caught between a theoretical rock and a political hard place. Postcolonial theory calls for, indeed demands, a return to the lost voices in the history books, there is a need to look beyond the colonialists' history, and 'rediscover' a past. However, for Spivak, many of the voices of the past are lost within a colonialist discourse, never to be recovered, as they do not exist within this discursive frame. Recognising this problem, Spivak offers a way of getting past this, or at least of overcoming it temporarily. She argues that the work of the theorists who try to retrieve the voices of the subaltern can be described as a

'*strategic* use of positivist essentialism in a scrupulously visible interest' (Spivak, 1990: 205). So, while theoretical improper, she believes the actions are justifiable as they are politically proper. Spivak's influential concept of strategic essentialism rests on this premise, that while we know the concept is flawed, it can be employed to achieve a positive result. It is a strategy that can be used to present a 'united' group; while strong differences may exist between members of these groups and they may be engaged in ongoing debate and even conflict, it is sometimes advantageous for them to 'essentialise' themselves and bring forward their group identity in a simplified way to achieve certain goals.

7. Bhabha and Nationalist Representations

Returning to the issue of nationalist representations, a focus that is blurred by the work of Spivak, the work of Homi Bhabha can now be introduced. Bhabha, like Spivak, crucially challenges the common-sense assumption that clear transparent language is the best way to represent the subjects of which they are writing; in this case the postcolonial subject. Bhabha emphasises the limitations of linguistic and philosophical representations and their potential to mask the ambivalence of the representation between coloniser and colonised. Like Said, Bhabha argues that colonialism is informed by a series of assumptions, which aim to legitimate its views of other lands and people. He states,

'The objective of colonial discourse is to construe the colonised as a people of denigrate types on the basis of racial origin, in order to justify conquest and to establish systems of administration and instruction.'

(Bhabha, 1994: 70)

However, Bhabha distances his stance from Said by arguing that emerging colonial stereotypes that represent colonised people in various derogatory ways are never fully fulfilled. This is because the discourse of colonialism does not function according to plan because it is always pulling in two directions at once. Bhabha calls this 'ambivalence', a term he has adapted from psychoanalysis, which is used to describe a continual fluctuation between wanting one thing and wanting its opposite. Applying this to the colonial situation, it questions the assumption that the colonised subject is always either complicit or resistant, instead Bhabha suggests that complicity and resistance exist in a fluctuating

relation within the colonial subject. This relates also to the colonisers' colonial discourse, as it is both nurturing and exploitative in the same instances.

This position is useful for disrupting the simple clear-cut authority of colonial domination. It disrupts the relationship between coloniser and colonised, making ambivalence an unwelcome aspect of colonial discourse for the coloniser, as colonial discourse needs complacent subjects who reproduce its assumptions and values. In fact, for the coloniser the most complacent subject is one who mimics their colonisers' culture. However Bhabha suggests that this mimicry often becomes closer to mockery. When examining specific instances of this, and applying it to Ireland, institutions and social relations that emerged following the 1916 Rising and the War of Independence, were not bastions of 'Irishness', but were instead replications of the English systems of which they had fought so hard to gain independence from (this is developed substantively in Chapter 6).

There is a double narrative moment associated with this ambivalence; the nation is being continuously split by the 'conceptual ambivalence' (Bhabha, 1994: 145) that emerges because of the two contradictory modes of representation occurring in the nation. Bhabha identifies this as pedagogic and performative, each of these stances possessing its own relationship with time. The disruptive 'double narrative moment' (1994:145) means that nationalist discourses are continually split and pulled apart. The pedagogic discourse of nationalism claims a fixed origin for the nation, and asserts a continuous, linear timeline of history. It is pedagogical because it warrants the authority, legitimacy and primacy of the nation as the central political and social frame within which the 'people' are unified and collected. The people are the object of pedagogical discourse; they are the body which nationalism constructs and upon which it acts (McLeod, 2000: 118).

However, with the performative aspect of nationalist discourse, the position of the people in relation to the discourse is inverted. In this mode of representation, which exists simultaneously with the pedagogic, the people are the subjects of nationalist discourse, as they are constantly involved in the ongoing production and rehearsal of nationalist icons and popular signs. 'The scraps, patches and

rag of daily life must be repeatedly turned into the signs of a coherent national culture' (Bhabha, 1994: 145) by the performance and repetition of the performance of signs and traditions associated with the nation. So the temporal aspect of this mode of representation does not rely on a link to the past, which can be traced through time, but instead is 'repetitious' and 'recursive' (Bhabha, 1994: 145).

The two forms of representation that are simultaneously occurring in the nationalist representations problematise the concept of nation itself as it means it is composed of two incompatible opposites. The first, from the pedagogical, conceptualises the nation as a fixed, originary essence, linked with a teleological sense of the past. The second, the performative, holds the nation as socially constructed and lacking a fixed nation, instead constantly being recast and rediscovered through the performance of traditions and the rehearsal of meanings. This problematises any sense of unity between the people of the nation, as the people constantly exist both as subject and object of nationalist discourse. The pedagogic aspect means that the people are part of an idealised image of unity and coherence, linked and bound together by their shared past. However, because this people is also the subject of the discourse, and is therefore the generating force of the discourse of nation, those people excluded from the pedagogic representation intervene in the signifying process and challenge the dominant representation with narratives of their own. The plurality of the performative discourse therefore destabilises the singularity of the pedagogic and,

'[w]e are confronted with the nation split within itself, articulating the heterogeneity of its population. The barred Nation *It/Self*, alienated from its eternal self-generation, becomes a liminal signifying space that is *internally* marked by the discourse of minorities, the heterogeneous histories of contending peoples, antagonistic authorities and tense locations of cultural difference.'
(Bhabha, 1994: 148)

Contrary to Spivak then, Bhabha fixes upon counter-narratives within the nationalist representations of themselves, highlighting the difference that comes from within, and 'disturb those ideological manoeuvres through which "imagined communities" are given essentialist identities' (Bhabha, 1994: 149). Counter-narratives problematise the self-generation of the nation by revealing different

experiences, histories and representations at the level of performative, which nationalist discourses cannot include.

So Bhabha's theory that the colonial relationship is always ambivalent means that colonisation inevitably generates the seeds of its own destruction as the position of the coloniser is undermined by the position of the colonised. This concept of ambivalence is closely aligned to another of the main tenets of Bhabha's thought, the related idea of hybridity. Just as ambivalence 'decentres' authority from its position of power, so that authority may also become hybridised when placed in a colonial context in which it finds itself dealing with, and often infected by, other cultures. Bhabha contends that all cultural statements and systems are constructed in a space that he calls the 'Third Space of Enunciation' (1994: 37). This space is reproduced in the work of Field Day as the 'fifth province'⁴ in which potential identities for Ireland could be explored outside the constraints of existing traditions, whilst at the same time renewing the investigation of the different pasts of Ireland, as discussed in the opening section of Chapter 1. According to both these positions, cultural identity always emerges in this contradictory and ambivalent space which, for Bhabha, makes any claim to a hierarchical 'purity' of cultures untenable. Cultural and imaginative life constantly traffics ambivalently between the poles of coloniser/ colonised, self/ other, white/ black, inside/ outside, West/ East, home/ foreign, and transgressively across those borders. All the time, cultural translations of ideas, images and practices from one register and mode of being to the next are taking place. Even the colonising consciousness, which aspires to emit self-images of mastery and to construct regimes of hierarchical certainty, does so only in the enabling rhetorical presence of the 'Other', which is cast as colonised, weak and silenced but also, importantly, feared and threatening (McLennan, 2003).

The 'in-between' space of ambivalence can be used in conjunction with Bhabha's liminality. Liminality derives from the term 'limen' meaning threshold, a word used particularly in psychology to indicate the threshold between the

⁴ There are four physical provinces in Ireland, with the fifth traditionally being used to represent something beyond physical; something spiritual. It is sometimes associated with the emigrant or simply as a meeting point for all the provinces; a joining of all the people of Ireland.

sensate and the subliminal, the limit below which a certain sensation ceases to be perceptible. The sense of the liminal as an interstitial or in-between space, a threshold area, distinguishes the term from the more definite word 'limit' to which it is related. This liminal space describes the transcultural space in which strategies for personal or communal selfhood may be elaborated, a region in which there is a continual process of movement and interchange between states. To demonstrate this state, Bhabha uses the artist Renee Green's installation depicting a stairwell as a liminal space. He describes how she,

'used architecture literally as a reference, using the attic, the boiler and the stairwell to make associations between certain binary divisions such as higher and lower and heaven and hell. The stairwell became a liminal space, a pathway between the upper and lower areas, each of which was annotated with plaques referring to blackness and whiteness'.

(Bhabha, 1994: 3-4)

So the liminal space is always a site of symbolic interaction, one which prevents polarising and dichotomising through the dissolution of binaries. As Bhabha writes,

'The hither and thither of the stairwell, the temporal movement and passage that it allows, prevents identities at either end of it from settling into primordial polarities.'

(Bhabha, 1994: 4)

This imagery of spatial distance throws into relief the temporal, social differences that interrupt our sense of cultural contemporaneity. The present can no longer be simply envisaged as a break from or a bonding with the past and the future, no longer a synchronic presence: 'our proximate self-presence, our public image, comes to be revealed for its discontinuities, its inequalities, its minorities' (Bhabha, 1994: 4). The complexities, nuances and empirical relevance of liminality will be discussed in Chapter 3 and used empirically in Chapter 8.

8. Postcolonialism and Sociology

The references to theory above have been primarily rooted in literary theory and cultural studies, with their emphasis and interest directed at textual representations and the manners in which discourse exists through and constructs

the text. This continues to be the realm in which postcolonial theory exists at its strongest and postcolonial theory is only slowly infiltrating sociological thought and enquiry. In fact, literary theorists have begun to lament the lack of empirical work relating to contemporary Irish society and the concept of the postcolonial (Connolly, 2004). Postcolonialism, especially with its poststructural emphasis, presents interesting issues to sociology's self-image, especially by opening debates on the modernist, Westernised aspects that are perpetuated through certain approaches common in the discipline. However, McLennan (2003: 69) has argued it is not apparent in much of the theory outlined above how a 'postcolonial unsettling of sociology' can be extracted and reconstructed from the key texts of postcolonial theory, and in fact anti-sociological impulses can be found through the writings of the more influential postcolonial theorists. McLennan (2003) is correct in describing these impulses but they can be understood as a privileging of the text rather than a denial of anything outside of it. This thesis rejects the idea that there is nothing in postcolonialism for sociology. While there are difficult questions raised around their use together, surrounding both theory and method, it does not mean that it should not be attempted. Rather, an engagement with these questions will benefit both sociology and postcolonial theory, as the section below will clarify.

The focus of the theory discussed above is on literature, and the various possible readings of canonical texts which are seen as representative of different arenas of the colonial experience. Theories of colonial discourses have been the most influential in the area of postcolonialism, and these theories have been concerned with representation and modes of perception as fundamental weapons of colonial power to keep colonised peoples subservient to colonial rule. Colonial discourses form the intersections where language and power meet. Language is always more than simply a means of communication, and in fact constitutes a worldview by cutting up and ordering reality. This view is widely accepted in the postcolonial theory that this chapter has dealt with, but the application of these theories is narrowed, rather than widen to its full potential; language is limited to its study in literature. The relation between culture and language is not disputed, but the mediums through which the language can communicate are brought down to novels and newspapers, a reality reflected through text.

There is diversity in the relation of the postcolonial theorist to the text, classified into different groups by McLeod (2000). These classifications are artificially simplistic, but are useful in indicating the general trends within postcolonial theory and as ways of thinking about the relationship between theory and text. This allows a further interrogation of the links between sociology and postcolonial theory. The first group of postcolonial theorists focused on re-reading canonical English literature, in order to examine if past texts perpetuated or questioned the latent assumptions of colonial discourses. This path branched into one group who examined novels and writers who dealt exclusively with colonial themes and argued if their works were supportive or subversive.

The second path looked at works which could not be explicitly described as colonial, such as *Jane Eyre* or *Mansfield Park*, but which can be re-read in terms of colonial discourse which uncovers subverted meanings. Second, there is a group who are concerned with 'writing back to the centre', a group of writers inspired by Fanon and Said, and later Bhabha and Spivak, who are interested in new literature which comes from postcolonial countries or develops themes of postcolonialism within their work. The focus of this group is the questioning and subverting of colonial discourses in their work. These works hold the local as their focus, and were interested in challenging the colonial centre and redirecting to the colonial margin. This group gave voice and expression to the colonised and once colonised people.

The third group of critics draw on the post-structuralist thought of Foucault, Derrida and Lacan, and are in particular concerned with the representation of colonised in a variety of colonial texts, not specifically literary ones. Now, this group would seem to support the relationship between sociology and postcolonialism, but in reality the focus of this group remains literary. This group is interested in times when the colonised subject showed resistance against the colonial discourse, and therefore demonstrated that the discourse was not all encompassing. The discourse that existed in these cracks was the focus of the group of authors which includes the 'Holy Trinity' (Young, 1995: 163) of Bhabha, Said and Spivak. This group offers the most enticing means of joining postcolonial theorising for a sociologist. While the writing of all these theorists

does remain literary in application the theoretical discussions which exist alongside this allows glimpses of possible empirical applications, and a move beyond the novel towards the use of this theory in relation to texts beyond the literary, as is demonstrated in this thesis. Of course, as stated above, these categories are artificial, and in fact this thesis draws heavily on the ideas found in the first and second groups as well as the third.

A common complaint in articles writing about contemporary Irish Studies is that there is little empirical testing of the claims made, using postcolonial theory, about culture and society but which are based on literature, and more pointedly, primarily non-contemporary literature. There is a strong reference to postcolonial discourses, and the voices which can be heard echoing around a postcolonial society (and the voices which cannot), but there is little actual application of the postcolonial to contemporary society, and the ways it is reproduced. If Ireland is viewed as postcolonial, then what does that actually *mean* to the society and its members? What cultural reference points and representations constitute the society as postcolonial, and what are the inherent assumptions about what it means to be Irish which go along with this? This thesis answers these questions, and begins to uncover the issues which go along with the answers.

The thesis applies strands from all three approaches above, looking for colonial representations of Ireland as re-presented, looking for 'Irelands' that exist in the 'cracks' of the colonial discourse, presenting alternative histories and voices, and looking at the processes which exist to decolonise the mind as found in Phoenix Park. The idea of past is interrogated, as are ideas relating to the nation and Irishness, through the interrogation of the texts, literary and beyond, which are constructed to represent the land and the people associated with the land. This is done through the adoption of various strategies employed in postcolonial readings of geography, using spatial readings and understandings of the various ideas discussed in this thesis.

The relationship between postcolonial theory and sociology unfolds as the thesis progresses, but the methods underpinning this research are sociological and so it

is the ‘unsettling’ of these methods by postcolonialism that allow innovation and development to try and find the best practical and theoretical means of dealing with the problems which emerge. The amalgamation of ideas from sociology, geography and cultural studies allows engagement with the postcolonial theories that emerge as important through the substantive work. This is a qualitative piece of research, and as such, the postcolonial theory used has emerged from the empirical work and has come through as the best way of engaging theoretically with the data. Issues surrounding the linking of postcolonialism and sociology emerge at the different points of this research project, and at different points through the thesis these are made explicit, in Chapter 4 and Chapter 7. Chapter 3 is another one of these points; where the different lineages of the concept of liminality are discussed, drawing on the anthropological heritage and a postcolonial heritage, and using ideas from sociology, cultural studies and geography to bring them together in a useful way for this thesis. Drawing ideas and approaches from these different ways of seeing the world allows an inclusive sociological imagination to emerge and facilitate engagement with the complexity and multiplicities that researching a postcolonial space presents.



Chapter Three: Mapping the Liminal

'I suspect no landscape, vernacular or otherwise, can be comprehended unless we perceive it as an organisation of space; unless we ask ourselves who owns or uses the spaces, how they were created and how they change.' (Jackson, 1984)

'This is an intervention. A message from that space in the margin that is a site of creativity and power, that inclusive space where we recover ourselves, where we move in solidarity to erase the category colonizer/ colonized. Marginality is our space of resistance. Enter that space. Let us meet there. Enter that space. We greet you as liberators.' (hooks, 1990)

1. Introduction

Liminality constitutes an important theme of this thesis, which holds different meanings and applications in a wide range of disciplines and ways of looking at the world. It can be found in art (for example *Rites of Passage* by Stephen Greenblatt at the Tate Gallery), architecture (Smith, 2001), philosophy (Foucault, 1998), psychology (Freud) and social theory (Hetherington, 1998; Shields, 1992), and represents similar concerns with a range of meanings across these disciplines. The similarity centres on the acceptance of liminality as representing a discourse in-between two positions or the juxtaposition of a dominant idea with a marginal discourse. This chapter uses this position as a starting point, developing the idea of the liminal as a way of understanding and developing empirical research by recourse to different cultural and epistemological understandings.

This chapter is divided into two seemingly distinct sections; the first focuses on the idea of liminality and the associated theories. The second moves to ideas of place and space and the way in which this can be understood in a postcolonial context in Ireland. A third section ties these two areas together, drawing on the theory presented in the previous chapter. The section on liminality first explores the postcolonial lineage, looking at the meaning around ideas of colonial and postcolonial discourse to uncover the cultural ideas of liminality that have theorised Ireland in a way that positions the discussion in a wider framework of

understanding of the postcolonial to enable a contextualised discussion of the development of the idea of liminality in postcolonial studies. Second, the anthropological lineage and specifically Victor Turner is explored. These two ‘definitions’ and uses of liminal inform the thesis as a whole. This chapter outlines these meanings, and the way the different lineages use the idea, tracing the emergences and first use of liminality and the reason it is important. It offers a genealogy of the use of the term through both lineages, tracing it in different disciplines and approaches as a way of understanding something cultural, material, spatial and historic. The second section focuses on the project of mapping, and the way in which this mediates relations between space and identity. The focus on mapping was important because of the constructive and descriptive process associated with it, and the way in which that overlaps with ideas of liminality. This chapter concludes with a discussion on the cultural ideas of the liminality of Bhabha and Turner, combined with spatial understandings of social theory in an idea of Thirdspace as forwarded by Soja, thus bringing together the ideas of space, place and liminality in a fusion of ideas drawing from different disciplines and ways of understanding the world.

2. Section One: The Liminal

This section is concerned with ideas of the liminal, as found in different ways of thinking about the social world. It begins with the postcolonial lineage and moves to an anthropological lineage. Following this, it looks at some of the ‘theorists on the margin’, people whose work has been influential in the development of this concept. A final piece in this section looks at the theoretical underpinnings of postcolonialism and the way the liminal can be understood in relation to these. The purpose of using these different approaches to liminality and drawing them together is to examine the different foci they hold and different ways they have applied the concept empirically, as a way of developing a working concept for this thesis.

2.1 The Postcolonial Lineage

The term ‘colonial discourse’ is used to signify power relations and mechanisms, and refers primarily to the means through which the colonist represents the colonised Other to themselves in a manner which articulates with the social,

political, economic and military interests of the colonial enterprise (Dorrian, 2001). The discursive subjugation of the colonised is achieved through the production of knowledge which adopts binary opposition, a mechanism rehearsed in the theoretical introduction to postcolonial theory in Chapter 2. Through this binary framework an economy of regulation is enacted which is, characteristically, problematised at certain points by the 'identity effects' (Bhabha, 1994) which it produces. Between these binary notions of Self/ Other, there was always an intensely unstable arrangements in which these notions were, as Derrida (1982) puts it always 'solicited' by each other and produced disruptive effects. By this, it is meant that the binaries are always unstable and the relationships between the two supposedly juxtaposed positions are linked; complementary and destructive at the same time. For Bhabha, this is expressed as an 'anxiety' always inherent in the colonial discourse, brought about by the idea of difference articulated through this discourse of the colonised, but continually undermined by the underlying similarity of the colonised people, and thus the continual undermining of the category of 'other'. This sameness emerges as the over-arching colonial discourse is broken down through personal contact, developed understandings and cultural assimilation. The assertion of difference through colonising discourses is primary to the quest for domination, relating to moral and cultural arguments, but this leads to anxiety within the colonisers discourse through the recognition that this dominance can never be fully articulated. There are always cracks in a discourse, where alternative understandings are developed. The colonisers' anxiety comes from the recognition that their authority is based on a flawed concept and that they are not morally or culturally superior to an entire people, or the stereotypes to which they have been reduced, an issue developed below.

There have been a number of developments in postcolonial theory since the initial flourish of excitement around Said's *Orientalism*, and which, ironically perhaps, have emerged partly as a reaction against this. Inherent in the construction of the notion of Orientalism⁵ was the silencing of the East, there were no means open for the East to subvert the notions of East which the West

⁵ Though found primarily in the academic discipline of orientalism, which studied the 'orient'.

was in the continuous process of forming, and this ideological deadlock⁶ frustrated those who saw the colonised as more active agents in the colonial process. So, while Bhabha follows Said very closely on the majority of his thesis around orientalism, he shifts the focus and emphasis to include the colonised. There is a danger with postcolonial theory of centralising the discourse of marginality with recourse to ideas of authority associated with academic texts which condemn the marginal to their inferior position. While this subaltern or marginal position may reassert the authority of one discourse or group over another, the oppressed group can also use their marginality to subvert the hegemony of authority. This has already been addressed in Chapter 2 where the ideas of Spivak are discussed in more detail in relation to this point.

Like Said, Bhabha recognises that traditional ways of thinking and assumptions about the world have often been complicit with longstanding inequalities between nation and people. In particular, self and other distinctions are immensely damaging to emergent cultural and societal relationships and, as such, he recognises the need to break down the oppositions of these binaries. Bhabha adopts a series of concepts to undermine the simple polarisation of the world, and emphasises the hybridity of cultures. He recognises that there is no such thing as pure or 'authentic' culture, and that instead we must recognise, even celebrate the mixedness or even 'impurity' of cultures. Instead of beginning with the idea of pure cultures interacting, Bhabha directs our attention to what happens on the borderlines of cultures, to see what happens in-between cultures. The result has been a diverse but nevertheless identifiable movement into what are called the 'liminal spaces' of colonial discourse. Liminality stresses the idea of that which is in-between settled cultural forms or identities, like self/ other, is central to the creation of new cultural meaning. This approach calls for a privileging of liminality in an attempt to undermine concepts of solid and authentic culture in favour of unexpected, hybrid and fortuitous culture.

Bhabha developed the idea of liminality from Freud's use of it as 'opposing pairs of instincts are developed to an approximately equal extent' (discussed in Childs,

⁶ This refers to the inability of the Orientalism to afford the 'east' a voice with which to refute the claims that were being made. Agency was not given to the 'east'.

1996: 123). This inherent ambivalence was used by Bhabha to prise open the dichotomy of coloniser and colonised which had previously dominated the theories of post-colonialism. Colin Graham (1995) notes that these developments in postcolonial theory, as evinced in the work of Bhabha, have resulted in a concerted move into 'liminal spaces' where oppositions, for example between the coloniser and the colonised of Said's *Orientalism*, are broken down through 'irony, imitation and subversion' (Graham, 1995: 33). There has been evidence of ideas preceding liminality in the work of most postcolonial theorists who engaged with issues, and Bhabha has articulated this and worked it to make it a usable and theoretically sound concept.

Fanon (1952) refused to allow the 'normal' categories of colonial life, such as 'black' and 'white', 'native' and 'foreigner' to be regarded as authentic or stable, as discussed in Chapter 2. His ideas were designed to show that colonial understandings of 'other' subjugated peoples were flawed and could not provide the basis for liberation either from external authority or from internal colonisation. He moves towards the idea of liminality by problematising the colonial binaries and recognising that there is more than a simple dualism present. However, the term 'liminal' is first used with relation to the colonial encounter by Said (1994) in the analysis of Rudyard Kipling's *Kim*, in which Kim's social and racial position allows him to move with relative, almost arbitrary freedom between coloniser and colonised, British and Indian, traversing and deploying the network of spying and intrigue which is layered over Kipling's India. By birth Kim is a white, Irish boy, Kimball O'Hara, whose father was a soldier in an Irish regiment. But he has grown up as an orphan on the streets of Lahore, 'a poor white of the very poorest', looked after by a half-cast woman, who is portrayed as a prostitute. As Said (1994) describes, from the start he is neither wholly British (he is Irish) nor wholly Indian, and his being neither wholly one nor the other, but a unique 'mixture o' things' remains a constant in his quest for his identity. He is in-between coloniser and colonised, and though the novel is 'A master work of imperialism . . . a rich and absolutely fascinating, but nevertheless profoundly embarrassing novel' (Said, 1994:45) it demonstrates this nascent conception of liminality which is recognised and emphasised by

Said. This is the beginning of the idea of liminality though Said does not develop it beyond recognising it in this instance.

Homi Bhabha's associated concept of ambivalence, highlighting the inherent instability in colonial discourse, becomes a commonplace term in post-colonial theory and together with his ideas about 'hybridity' and the 'third space', are intricately linked with the idea of liminality. The idea of the stereotype illustrates Bhabha's dual concepts of anxiety and ambivalence. The stereotype functions to enable colonial authority (and other forms of authority), providing the justification that the coloniser rules the colonised due to innate superiority. However, Bhabha contends that there is a simultaneous anxiety built into the operations of colonial knowledge. This is because authority recognises its basis in stereotypes, producing prejudiced and discriminatory structures of governance that work on the basis of forms of stereotyping knowledge. Additionally, colonising rule is informed by supposedly civilising ideals. So on the one hand Western political and economic institutions coexist with the ideologies of superiority, and this coexistence allows colonial power to be exercised, simultaneously anxiety troubles the source of colonial authority due to the implicit sameness of the colonised. This leads to a split in enunciation, due to the excess production of knowledge necessary to ensure the ongoing production of stereotypical knowledge about the colonised. This ambivalence or anxiety is necessary for the production of new stereotypes, but it is also the space for counter-knowledge and strategies of resistance and contestation. As Bhabha summarises,

Racist stereotypical discourse, in its colonial moment, inscribes a form of governmentality that is informed by a productive splitting in its constitution of knowledge and exercise of power. Some of its practices recognise the difference of race, culture and history as elaborated by stereotypical knowledges, racial theories, administrative colonial experience, and on that basis institutionalise a range of political and cultural ideologies that are prejudicial, discriminatory, vestigial, archaic, 'mythical', and crucially, are recognised as being so [...] However, these coexist within the same apparatus of colonial power, modern systems and sciences of government, progressive 'Western' forms of social and economic organisation which provide the manifest justification for the project of colonialism'

(Bhabha, 1994: 83)

While this quote highlights the colonial moment as a specific instance of this occurrence, Bhabha does not in practice limit his sense of the stereotype in this way. He recognises the difference in use of stereotypes as a means of practical control, and, separately, the philosophical 'civilising' justification of the colonial enterprise but highlights that the two are 'necessarily inseparable', with one always undermining the other, 'the phantasy world' (Huddart, 2006) of the stereotype always invading the coloniser's narrative. Concurrently, all forms of colonial identification need to be seen as 'modes of differentiation, realised as multiple, cross-cutting determinations, polymorphous and perverse, always demanding a specific calculation of their effects' (Bhabha, 1994: 67, drawing on Freud's polymorphous perversity phase in development terms). So stereotypes must be regarded each time singularly, rather than as examples of grand general patterns which can be dismissed.

The articulation of stereotypes provides a moment of knowledge production which reinforces ideas of the stereotype, whilst also allowing a counter-resistance and recognition of the inherent ambivalence which exists in the colonial discourse. The recognition of this ambivalence transforms the main problems of stereotypes from that of their false representation to their gross simplification due to their fixed, arrested forms of representation that do not recognise the play of difference which the negation through the Other permits. Colonial discourse is constructed as fixing identity and denying it any chance of change. Bhabha recognises that this is a fallacy, and forwards the idea of difference, ambivalence and liminal space as a way of countering it.

2.2 The Anthropological Lineage

Turner's concept of the liminal drew on and developed the work of the early 20th century anthropologist Arnold van Gennep. In rituals marking transformations in individual lives, from child to adult or single to married, or in the life of the group, from peace to war or change of season, van Gennep noted that those involved pass through, or beyond, the threshold of traditional or conventional behaviour and emerged changed. For van Gennep ritualized performance remained an activity distinct from daily life, in fact, defined by its distinction from daily life and one that, contained within established ritual, played the

basically conservative function of keeping change within the boundaries of tradition (van Gennep, 1960). Van Gennep theorized that rites of passage have three principle stages: rites of separation, margin or limen (or threshold), and reaggregation. Van Gennep's structure can also be understood as a pre-liminal phase (separation), a liminal phase (transition), and a post-liminal phase (reincorporation).

Turner gained notoriety by exploring van Gennep's threefold structure of rites of passage and expanding theories on the liminal phase. Turner noted that in liminality, the transitional state between two phases, individuals were 'betwixt and between', and they did not belong to the society that they previously were a part of and they were not yet reincorporated into that society. Liminality is a limbo or a purgatory, an ambiguous period characterized by humility, seclusion, tests, sexual ambiguity, and *communitas* or unstructured communities where all members are equal.

Based on his fieldwork among the Ndembu, Turner (1974) asserted that social dramas have 'four main phases of public action, accessible to observation' (1974: 38) which are breach, crisis, redressive action, and reintegration. The first phase is 'signalized by the public, overt breach or deliberate nonfulfillment of some crucial norm regulating the intercourse of the parties' (1974: 38). Once a breach occurs a phase of mounting crisis supervenes in which the breach widens and extends the separation between the parties. The crisis stage has 'liminal characteristics, since it is a threshold between more or less stable phases of the social process' (Turner, 1974: 39). The third phase of redressive action occurs to limit the spread of the crisis with 'certain adjustive and redressive mechanisms [which] are swiftly brought into operation by leading or structurally representative members of the disturbed social system' (1974: 39). Turner further identifies the mechanisms of this phase as ranging from personal advice and informal mediation or arbitration to formal juridical and legal machinery, and, to resolve certain kinds of crisis or legitimate other modes of resolution, to the performance of public ritual. However, some mechanisms may not work; in which case regression to the crisis phase occurs. The redressive phase is the 'most liminal' because it is in the middle of the crisis and the resolution. It is in

this phase that the liminal ritual may be enacted to resolve the crisis and provide an opportunity for the final phase of reintegration to occur. The reintegration phase involves the resolution of the conflict by reintegrating the disturbed group into society or by the 'social recognition and legitimization of irreparable schism between the contesting parties' (1974: 39). This four-phase model fits into van Gennep's phases of rites of passage; breach and crisis correspond to van Gennep's separation phase, redress aligns with the transition phase of rites of passage and reintegration represents van Gennep's incorporation phase. It was in his extension to include social dramas as a means of understanding and explaining ideas of the symbolism of conflict and crisis resolution that Turner developed and reworked the ideas found in van Gennep's writings.

Liminality often involves a blurring of roles and attitudes which, for Turner, is emblematic of life on the margins. This was a space of transformation between phases of separation and reincorporation. It represented a period of ambiguity, a marginal and transitional state. As he summarises,

'Liminal means being on a threshold, [...] a state or process which is betwixt and between the normal, day to day cultural and social states. [...] [S]ince liminal time is not controlled by the clock it is a time of enchantment when anything might, even should, happen.'

(Turner, 1977: 33)

Liminal opportunities arise when the mystical intrudes on the mundane. The results of such intrusion are diverse for, as Turner (1977) observes, structure generates 'finiteness and security' whereas liminality is 'the acme of insecurity.' Such a 'breakthrough of chaos into cosmos' can be the 'scene of disease, despair, [and] death'. Consequently, he explains, 'liminality is both more creative and more destructive' than common events in everyday life (Turner, 1982: 47). The experience of liminality is a socially uniting one. Underscoring the sense of the liminal is the perception of unmediated encounters with other individuals also momentarily stripped of their social status (Turner, 1982: 82).

Liminal activity, which Turner saw as primarily relevant to tribal and early agrarian societies, was ritualized performative activity which broke social norms

in order to reintegrate the individual or group back into the social norm. Turner introduced another term to develop this idea; the liminoid. Liminoid activity, which has evolved since the industrial revolution and the consequent distinction between work and play, is a less ritualized, more individualized and playful performative activity from which innovation and social transformation can grow (Turner, 1982; Chesters and Welsh, 2006). This distinction between the liminal and the liminoid is extended further. The liminal rituals were important for small-scale societies gaining a self-understanding, and were seen as a means of renewal of that society and a process of integration.

Liminal phases were associated with acts of transgression, and as Hetherington (1998) notes this was also an act of reordering and social integration, rather than simply some unfettered, counter-hegemonic form of resistance. A translation of the liminal into Western culture developed the need for a less ritualistic, less constrained set of occurrences, and this is what the liminoid became. The liminoid was achieved rather than ascribed, whereas with the liminal there was little choice in participation of the rites of passage. Despite the ideas of freedom and escape associated with the liminal they were obligatory, whereas with liminoid rituals they were more ludic in character. The third way in which liminoid and liminal rituals differed is of central interest for this chapter, examining the different nature of space in each. Liminal spaces exist betwixt and between sacred and profane spaces; they are the 'dangerous and polluting' margin (Hetherington, 1998). They are dangerous in the symbolic sense of mingling the sacred with the profane.

For this reason, liminal spaces are clearly demarcated and associated with their own practices, and the societies in which they exist have to be clear about their existence and reasons for existence. Liminoid spaces on the other hand, exist in societies that do not have clearly demarcated sacred and profane space. However, this doesn't mean that they do not carry symbolism. Liminoid spaces are likely to be created out of spaces that still retain some degree of *symbolic significance* as marginal or *transitional space*. According to these distinctions, Phoenix Park is more closely aligned to the liminoid than the liminal. In addition, Turner (1982) goes on to say that liminoid spaces are the space of leisure

activities and political protests with a strong carnivalesque element. The Park powerfully incorporates elements of both leisure and protest throughout its history. The liminoid ritual is seen as having ‘significance as sites for the production of new symbols for new modes of living’ (Turner, 1982: 33), and as places which allow a move away from structural constraints. According to this anthropological lineage, liminality is associated with ephemerality and transitional passage between alternative sites.

This research is aimed at examining these issues in relation to Phoenix Park and the way in which the meanings of liminality found in this ‘lineage’ intersect and overlap with those from the postcolonial ‘lineage’. By combining ideas from the liminal and liminoid of Turner and the anthropological lineage, with the liminal, ambivalent and hybrid of Bhabha and postcolonialism, this research positions itself within an epistemological and cultural position normally overlooked by research on the postcolonial and spatial. The use adopted in this thesis moves away from the specific anthropological meaning, though adopts it conceptually; the interstructural situation in which persons can be positioned in the liminal of Turner and van Gennep is not as appropriate for the research undertaken. This use implies that there is a structure for the liminal to be marginal of, and that there are fixed categories (self, Other, young, old, in this case coloniser, colonised) between which it can be positioned. This thesis adopts the idea that, in fact, identities are multiple and mobile, a position that is more sympathetic with the postcolonial lineage and understanding of this idea. This adopted understanding of liminal moves towards Deleuze’s (1993) idea of the fold, where there are no points or positions, just lines of flight where the relationships are multiple, lateral and circular in nature.

2.3 Theorists on the Margin

This section develops on the discussion above by looking at how different theorists have incorporated uses of liminality into their work. The development of identity and the negotiation of identity politics is a complex system of relationships and representations. Within marginal spaces a creation of transitional identification occurs out of which new identities emerge, and this is paralleled with the work done on heterotopic spaces (Foucault, 1986; Lefebvre,

1991), which are characterised by their co-existence and movement between different spaces and meanings.

Shields (1992) developed the idea of the liminal to understand the spatial and epistemological in a manner which incorporates elements from the postcolonial and anthropological lineages. For him, liminality represents ‘liberation from the regimes of normative practices and performative codes of mundane life because of its interstitial manner’ (1992: 82). He uses the idea of the liminal in a spatial way through location, with, for example, his discussion of Brighton as ‘liminal’ to London, but also in cultural practice, as the bathing practices and dirty weekends of Brighton through the decades locate the space in a marginal zone of cultural activity.

Shields (1992) interrogates the idea of the spatial through social theory, demonstrating the holes that have been left by the classical disregard of the spatial in ideas of the social. This theoretical enquiry raises the same issues analysed here via Phoenix Park, celebrating that, ‘[s]ites are never simply locations. Rather, they are sites for someone and of something.’ (1992: 6). His methods pursue the meaning that each of his chosen sites represents, building the layers through history and culture, secured in space. He develops the importance of this line of enquiry through the recognition that, ‘the spatial has an epistemic and ontological importance - it is part and parcel of our notions of reality, truth and causality’ (1992: 7). The idea of social spatialisation – the empiricised unity of what was theorised as such, as a social construction of the spatial and its imposition and enactment in the real topography of the world, underpins the methods of this thesis and informs the social theory.

Hetherington (1996, 1998) engages with liminality through an examination of shrines and the social and cultural processes associated with them. For this he draws extensively on Turner and van Gennep, looking at the processes which occur during this marginal or liminal period or transition and influence ideas of identity. Marginal spaces are regarded as something different; spaces for identity politics to occur. This work looks at the spatial importance of these spaces; outside a city, the woman’s peace camp at Greenham Common during the 1980s

(Stallybrass and White, 1986), and Hetherington's own work on New Age Travellers and sites like Stonehenge for their identity politics. The key element for Hetherington is the recognition that margins are more complex spaces than they may first appear. They are a 'complex, folded and crumpled topology rather than the simpler Euclidean one' (Hetherington, 1998: 126), which draws on Deleuze's (2004) idea of folding. Elaborating this, it becomes important not to focus solely on the relationship between marginal spaces and the complex, but also the relationship between those marginal spaces and the identity politics that have been associated with them. If the relationship between centres and margins is a folded one, so too is the relationship between resistance and transgression and the social order it seeks to challenge. The interaction between margin and centre, related to the concepts of self and other, both complex systems, is where identity politics are negotiated and discovered, the entire time hybrid; or topologically complex, heteroclitic, anomalous, confused, multiple, dispersed and fragmented.

The postmodern projects of deconstructing master narratives, unsettling binaries and admitting marginalized knowledges follow closely the objectives of the postcolonial critical project. Similarly, these various perspectives are conjoined in their attention to the relationships between discourses and powers, the socially constituted and fragmented subject and the unruly politics of signification – the workings of irony, parody and mimicry (Ashcroft et al, 1995: 117; Chesters and Welsh, 2006). Indeed, some writers have developed this link to demonstrate the tie between poststructuralism and postmodernism and the postcolonial. The questions that have become so much a part of the post-structuralist canon – otherness, difference, irony, mimicry, parody, the lamenting of modernity and the deconstruction of the grand narratives of European culture arising out of the Enlightenment tradition – are possible, it could be argued, because of their postcolonial connection (Ahluwalia, 2005). Therefore, it would appear to at least call into question the idea that postcolonial theory is epistemologically indebted to both poststructuralism and postmodernism, in a way which would suggest subservience and theoretical vulnerability on the part of postcolonialism.

The necessity to locate theory within the culture from which it emanates requires us to position the ideas of poststructuralism in a spatial way, as well as examining the political and economic shifts which occurred at a similar time. This colonial discourse can be found through the continued, though now reflexive, work done in postcolonial societies whereby the subjects of the colonial discourse recast themselves as the objects of a new idea of the nation through which they can articulate a new position in relation to this colonial discourse. However, this position continues to be influenced by the colonial discourse of the past, which assumes a position of inverse authority, still orchestrating and enabling but also functioning in a manner perverse to the ideologies of its insurrection. The contemporary manifestations of this colonial discourse can be traced and understood by looking at specific sites where they may be more visible, or through which certain practices can make them more visible.

3. Section Two: Land and Identity

This thesis materially positions these cultural discourses discussed above, and the following section begins to demonstrate how. An understanding of space is necessary to begin to understand Phoenix Park, and this section demonstrates the importance of including space into any discussion. The process of mapping is used to demonstrate this relationship while also providing more information around the colonising process in Ireland. In addition, as the home of the Ordnance Survey in Ireland, Phoenix Park has strong links with this activity.

3.1 Place, Space and Identity: Mapping the Terrain

Land has a position of central importance in this discussion of Ireland, as it has become discursively defined as more than simply a place of residence or a manner of sustenance. The last few decades of the nineteenth century in Ireland were dominated by the Land War, the organised agrarian protest against high rents and the landlord system that began in 1879 and continued intermittently until even 1923 (Hansson, 2003: 121). Irish popular history at the time circulated a version of the country's past where complex political allegiances and webs of interrelationships were suppressed in favour of a linear narrative of oppression and resistance. A necessary component of the linear view of history

was a fixed conception of space, and consequently as part of the reshaping of the past there was also a reshaping of the landscape into Irish and English territories. Combined historical and geographical discourses helped to create a concept of nationality and cultural identity that was embedded in the land, so that by the 1880s landlords of the Ascendancy class were automatically associated with British rule and the tenant farmers were just as automatically perceived as representatives of the 'real' Ireland. Both landlords and members of the Land League (the organised farmers) rhetorically articulated places as territories to be claimed, which meant that questions around issues of possession, dispossession and repossession came to the fore. Landlords lay claim to the land through centuries of land rights which sided in their favour, whereas for the Land Leaguers ousting the landlords would be one step closer to abolishing English influence and 'reclaiming' the land for the Irish. These two positions are embedded in a discourse which does not problematise the idea of place at all. In fact, they share the same view on the issue. Despite their differences over issues of ownership, both sides accepted that places pre-existed and could be measured and described, and ultimately owned or seized. In fact, to expand this point, issues of identity become intimately linked with issues of place. To be 'Irish' was to be related to the land in a certain way, whereas to be 'English' required another means of interaction. This binary is deceptively tidy. Relationships with the land did not fall so neatly into these set categories, and so such a measurable indicator of identity comes under intense scrutiny. The silenced voices in this model must find other ways to assume identity, they must find a space in between this binary in which they can exist.

3.2 Landscape and Colonialism: Mapping the Colonised

Land and place can be located in English colonial discourse relating to Ireland from the sixteenth and seventeenth centuries. During this time an impressive body of analytical, survey and descriptive literature was produced which was associated with the Tudor and Stuart 'reconquest' of Ireland, and can be regarded as indicative of the beginning of English colonial theory. There is a strong spatial element in this literature and the binary discussed above is seen in its inception, as a colonial regime of space. This 'regime of space' (Dorrian, 2001) is demonstrated most visibly on the scale of landscape and settlement, but can

also be extended or, more appropriately, reduced to the scale of the body in its practices, fashioning and department. The spatial formation of the colonial land can be understood in the context of the chain of spatial elements, in terms, for example of the colonial rhetoric dealing with the surface and depths of the land, with penetration and arable cultivation and with the colonist-husband (Dorrian, 2001: 27). Modes of territorial organisation answering demands for military, economic and administrative efficacy are also likely to respond to the colonial project of bringing form to the 'formless'. Indeed, the power of colonial ideology largely hinges on this congruence between the emanations of the political and the metaphysical, between the levels of practice and of legitimising narrative. The idea of *terra nullus* has been rehearsed in arguments in Australia relating to the Aboriginal claims to land ownership. These claims are disputed due to the legal belief that Australia's land was *terra nullus* or unowned before the colonising British came to claim it, and therefore ownership stems from this moment. This has long term implications, underpinning the UK use of Australia for nuclear tests in the 1950s and contemporary Aboriginal claims to compensation and the return and cleanup of the land which was taken from them. The land prior to claims of ownership, as Dorrian (2001) discusses in relation to Ireland, was formless and did not exist in any recognisable form within Western discourse.

The need for mapping and categorising the landscape of the colonised became a central tenant of the colonial project and through this new geographical techniques and mapping procedures were developed. Beginning in the fifteenth century, as the landscapes of the world successively became geographic objects of European power, landscape became an object of increasingly professionalized geographic knowledge (Sluyter, 2002: 3). The explorer who textually or cartographically represented landscapes generated an increment of geographic knowledge at the same time as producing a prospectus and resource for the extension of European power through space (Sluyter, 2002). Similarly, the colonial bureaucrat who developed techniques to classify and analyse landscapes refined geographic method at the same time as consolidating European surveillance and control (Sluyter, 2002). Landscape was therefore a central component of the developing colonial project. Through making land visible in this way, the surveys constructed from what was encountered on the ground into

an ordered scene that could be 'read'. Such practices were not simply textual but highly material; they did not leave the land untouched. Instead, they actively displaced and resituated landscapes within new orders of vision and visibility, and within regimes of power and knowledge that at once authorised new forms of governmentality. The people who were already there, and did not fit into this new discourse were not simply erased. Instead, they were components of the thorough description, they were described and categorised in a manner which removed them from the unfolding 'modern' nation, and instead saw them as a 'primitive' culture, a barbaric and uncivilised presence which, in the same way as the land, needed to be cultivated.

3.3 An Exercise in Colonialism: Mapping Ireland

In 1842 the most extensive mapping project ever to occur in Ireland was begun. This project, undertaken by the British Ordnance Survey, was set to produce a whole map of Ireland at a scale of six map inches to every mile on the ground. The colonial presence was made highly visible during this activity, with the soldiers carrying out the mapping dotting the landscape in their bright red coats. This held a dual purpose within the same objective; the highly visible soldiers did carry out mapping, which led to the Irish landscape becoming something known and therefore controllable, but it also made the British presence very visible which led to an increase in internal control as the presence was recognised. This was the first map of this level of detail ever carried out and it was an exercise in colonialism for the British.

This exercise was an act of colonial domination, a means for Britain to maintain control over Ireland, making the landscape, its people and past known and quantifiable (Smith, 2003). The official impetus for establishing the British Ordnance Survey of Ireland was to produce a national map to re-evaluate the county tax (which paid for many of the roads and bridges in the country) (Smith, 2003). Prior to this, the system of land ownership in Ireland was complex, which often led to confusion over who had to pay taxes. This map reduced the complexities to the mathematical statistics destined to simplify the tax process. In fact, the complexities were reproduced in the maps in different ways.

The mapping exercise must be understood as a site of cultural negotiation. The map of Ireland was produced through varying levels of interaction between the surveyors in the field, the Ordnance Survey officials in Phoenix Park, the local Irish people and their Anglo-Irish landlords. There are always multiple ways of perceiving the landscape as well as the social memories and meanings encoded therein. Maps, again, must be viewed as products of cultural negotiation in which competing perceptions and experiences of the landscape and its social history have been manipulated. Consequently, the mapping was not a cognately objective act but instead must be recognised as a tool of power initiated to know and control the local landscape and people. This was a process which involved interaction and relations that are contested at the international level (colonial), national level ('Irish') and at the local level. The spatiality represented in the maps is both produced by and helps to produce social relations of power by encoding and depicting space that is simultaneously physical, social and ideological (Foucault, 1984; Soja, 1989).

Aspects of the maps ideological content are clearly represented. The gentry's large houses and the trees which lined the driveways of the houses were anomalous against the otherwise empty landscape. Ireland had been largely deforested, and any trees which were planted for aesthetic reasons were clear symbols of affluence. This meant that the areas owned by the landed gentry, a predominantly Anglo-Irish Protestant class, stood out when looking at the map. In contrast to this, tenants lived in dispersed and isolated farmhouses, or in small clustered settlements called *clachans*. Most of the Irish people lived in *clachans* on marginal lands but the maps did not show these clustered settlements, despite the scale of the map allowing for their inclusion. This changed the function of the survey, from recording the land to bearing witness to its ownership. The maps had succeeded in depicting and reinforcing the social class structure within the nation, emphasising that the local-level control was in the hands of the Anglo-Protestant gentry class and stressing a colonial present and history. Indeed, another example was also evident which demonstrated the maps portrayal only of one culture, one ideology and one history. The mapping took place only eight years after Catholic Emancipation (1829) an act which had essentially legalised the practice of Roman Catholicism. At the time there were

not many Catholic churches, though the number was increasing. However, on the map, 'church' referred only to Church of Ireland (Protestant) churches, thus sending a clear message of supremacy that Church of Ireland was the only 'official' religion of the state. In a similar vein, the maps identified as 'Schools' only the newly formed 'national' schools which held, as a primary aim, the infusion of rural and marginal areas with the English language in a state led attempt to suppress Irish, the reasoning behind which has been discussed in Chapter 2. It was illegal for the Irish to congregate and so there was no representation of any Irish institutions, standing in stark contrast to the marked public building representations of national control that were the schools (Smith, 2003).

During this time, it is important to recognise that there were various groups meeting to try and challenge colonial governance, and so the mapping process was a dual attack against such activities. On the one hand, the increased presence of soldiers on the ground meant that there was an increased and closer gaze on the land and the actions which happened on it. On the other hand, the maps portrayed an image that silenced the unrest and depicted a land of colonial order and control. It was through these techniques that the mapping process managed the land. In Said's afterword to the 1995 reprint of *Orientalism*, the author proposes that the task of the critical scholar of imperialism is to connect the 'struggles of history and social meaning' with the 'overpowering materiality' of the 'struggle for control over territory' (1995: 331-332). Indeed, imperialism is, for Said (1993: 271) 'an act of geographical violence through which virtually every space in the world was explored, charted, and finally brought under control'. Imperial expansions established specific spatial arrangements in which the imaginative geographies of desire hardened into material spatialities of political connection, economic dependency and architectural imposition and landscape transformations. By recognising this, it is possible to understand the scale of the mapping project in Ireland and the ramifications, both cultural and material that it held.

3.4 Down to Earth

The purpose of the preceding section is to illustrate that landscape is not an objective, formed, categorised space. Instead, for the purpose of clarity, a theoretical distinction can be made between space and place. Space defines landscape, and where space is combined with memory place emerges. This memory can be constituted in different ways, and can be a personal memory, or a 'collective memory' which can be passed on through parents, schools or other institutions (media, local knowledge, etc.) If space is where culture is lived, then place is the result of their union (Lippard, 1997). And the culture which constitutes place, the way in which this transformation (in no way other at this point than in a theoretical sphere) from space to place occurs is through the narratives which come together and pull apart to form a place. The narratives and discourses of the colonial encounter intertwine in contemporary times with the daily narratives and discourses of life, and in this way the multileveled and interwoven qualities of place become apparent. The space becomes a site where numerous different places can and do occur simultaneously. The interactions and actions of people which constitute their relationship with the place can only be understood through a detailed examination of the narratives they employ and the discourses they exist in/ through with regard to the place (this relates to Macnaghten and Urry, 1998 on dwelling perspective). The symbolic significance of space in the construction of identity has been rehearsed already in this chapter and it must be continually used in developing theoretical thinking around Phoenix Park.

4. A Third Space?

The sociological imagination has been confronted with ideas of the spatial since the 1960s, which has led to the questioning of many pre-held idea(l)s and notions. Without reducing the significance of life's inherent historicity and sociality, or dimming the creative and critical imaginations that have developed around their practical and theoretical understanding, a third critical perspective, associated with an explicitly spatial imagination, has in recent years begun to infuse the study of history and society with new modes of thinking and interpretation (Soja, 1989: 261). This growing awareness of 'the simultaneity and interwoven complexity of the social, the historical and the spatial, their

inseparability and often problematic interdependence' (Soja, 1989) means that it is now necessary to rework methods which have been exclusionary and unable to develop into a new means of examining and understanding. It is important not to underestimate these statements.

What is being proposed does not simply involve the inclusion of issues of space and place into previous ways of looking and understanding the world, instead, these new developments revolve around what can be described as an ontological shift, a fundamental change in not only understandings of the world, but also the processes and methods through which we achieve this. As Soja describes,

'[T]here were earlier attempts [...] to give to this existential being and to its dynamic expansion in the notion of 'becoming' a pertinent spatiality, but until very recently this spatiality remained fundamentally subordinated to dominant dialectic of historicity-sociality, the interplay between what might more collectively be called the making of histories and the constitution of societies.'

(Soja, 1989: 261)

For Soja and others (Anderson, 2002), there is a need for a third addition to this dualism, an ontological trialectic of spatiality – sociality – historicity. By developing this triangle of understanding, what Soja is doing is re-emphasising the social production of human spatiality or the 'making of geographies', which is becoming as fundamental to understanding our lives and our life world as the social production of our histories and societies. This follows Lefebvre's (1991) 'spatial triad' of representations of space, representational space and spatial practice which form the central epistemological pillar of *The Production of Space* (1991). Lefebvre does not expand on this triad extensively, explicitly referring to it only in the opening chapter of his opus, and indeed he leaves us to add our own flesh and to re-write the triad as part of our own research agenda (Merrifield, 2000). This is because it is not a mechanical framework or typology he's bequeathed us, but a dialectical simplification, fluid and alive, and each moment messily blurs into other moments in real life contexts. This triad informs this thesis and the focus on the Park as a space/ place of human history and social life. The Park is not seen as stage where life is acted out, instead it

shapes life through the material and metaphorical influence it has on the life that exists in and constitutes that park.

These three interactive relationships apply not only to ontology, but also equally well to all other levels of knowledge formation: epistemology, theory building, empirical analysis and praxis and the transformation of knowledge into action. The three terms and the complex interactions between them should be studied together as fundamental and intertwined knowledge sources, for this is what 'being-in-the-world' is all about. This does not advocate the unquestioned recourse into the realm of the human geographer. Indeed, that discipline is confined extensively by an encompassing dualism or binary logic that has tended to polarise spatial thinking around such fundamental oppositions as objective/subjective, material/ mental, real/ imagined, things in space/ thoughts about space. It is therefore part of this project to deconstruct the dualism and to encompass the equally crucial elements of the social and the historical.

A central part of this new approach is a revised means of thinking about space. The inclusion of an idea of a 'Thirdspace' (Soja, 1996) or Representational space /'lived space' (Lefebvre, 1991) allows the ontological ideas to be applied to an empirical enquiry, a problem which adopting postmodern and poststructuralist theory realises. In the Thirdspace of Soja, influenced by Lefebvre's notion of representational space/ *espace vécu* or 'lived space', is an alternative mode of spatial enquiry that extends the scope of the geographical imagination beyond the confines of what Soja describes as Firstspace and Secondspace epistemologies and what Lefebvre refers to as spatial practices or 'perceived space' on the one hand, and the representations of space or 'conceived space' on the other. These statements are at the moment basic and will be used as starting positions on which other theories and theorists can be added to and elaborated by. Massey (1992) has helped develop the recognition of the spatial through the dissemination of her works and she embraces Bhabha's idea of Thirdspace. As one of the foremost thinkers and writers on space, her recognition of Bhabha's work is vindication of how his work can be applied to ideas of the spatial.

To clarify the ideas of Firstspace and Secondspace is necessary to understand what it is that is being 'moved beyond'. Firstspace (linked to Perceived Space for Lefebvre) refers to 'the directly experienced world of empirically measurable and mappable phenomenon' (Soja, 1996: 265). This is the material element of spatiality, that which has been the dominant and familiar focus of geographical enquiry. The scientific enquiry underpinning much geography seeks to categorise and classify rocks and soils and is the symbolic figurehead of this theoretical space. Accuracy and prediction inform the empirical enquiry associated with it, and correlation and validity determine the acceptance of the results⁷. However, this process is contained within geography, the empirical analysis, theory building and explanation remain internal to geography, that is, geographies are used to explain other geographies. This idea of 'Firstspace' and 'Secondspace' extend beyond geography and indeed resonant in alternative academic (and other) arenas. In sociology, a 'Firstspace' approach can be detected in empiricist accounts of social life whereby that which can be detected by the senses is all that exists. The idea that there is an empirical world 'out there' which can be discernibly mapped and measured is a characteristic of quantitative research. Based in positivist ideas and confined by scientific ideals this approach neglects the more opaque aspects of social life, and in many cases also the aspects which do not 'fit' the idea of society to which it subscribes.

'Secondspace' (Conceived Space or representations of space for Lefebvre), in contrast, is more subjective and 'imagined'. The concern of inquiry based in this space focuses on images and representations of spatiality with the thought processes that are presumed to shape both material human geographies and the development of a geographical imagination (in equivalence to a sociological imagination). The 'Firstspace' focus on materially perceivable spaces and geographies is replaced with an emphasis on more cognitive, conceptual and symbolic worlds. Although there is epistemology to the study of Firstspace, it is in Secondspace that epistemological discourse receives the greatest attention. For Lefebvre, the term Secondspace would be misleading, as his Conceived Space is in fact the dominant space in that it powerfully controls the way we

⁷ Satellite telemetry and advances therein reveal the limits of physical mapping as 'accuracy' increase; coast lines alter almost continually, for example.

think about, analyse, explain, experience and act upon or 'practice' human spatiality. Ideology, power and knowledge are embedded in this representation, and it is the sphere of planners, engineers, developers, architects, urbanists and geographers (Lefebvre, 1991). And indeed, within sociology, there has been a shift since the 1960s to the sort of methods which could be included under the Secondspace heading. These methods would represent qualitative methods such as interviews, focus groups and ethnographic inquiry.

Following Lefebvre (1991) and Foucault, Soja problematises this persistent dualism. He believes that this has been responsible for the difficulty many geographers and other spatial thinkers have in understanding and accepting the deeper meaning of the ontological restructuring discussed earlier and hence in understanding 'Thirdspace' (Lived Space) as representing a new way of thinking. Thirdspace attempts to break down the 'categorically closed logic of either/ or' in favour of a different, more flexible and expansive logic of the 'both-and-also' (Soja, 1996: 258). The potentials for this position in relation to postcolonial enquiry are extensive and as the discussion progresses it will be argued that this position is fundamental to the ideas of postcolonialism and indeed strengthen the theoretical argument of both by their overlapping application in this thesis.

Thirdspace can be understood as a means of escape from the closed binary logic of Firstspace – Secondspace, a means of escaping what Soja (1999) calls the 'bicameral confinement' of this form of dualism. He recognises that this involves an 'ontological restructuring' to accept the 'profound challenge' of changing the way we think. Drawing on Lefebvre and Foucault this allows a new way of regarding space. The work of Lefebvre has been threaded through the discussion above, with reference to his idea of Lived Space as something akin to that of Thirdspace, and from Foucault we can take the idea of 'heterotologies'; space embodies multiple microphysics of power. For Lefebvre, the persistent dualism between mental and materialist approaches to space, or between what he called spatial practice and the representation of space, was a form of reductionism that was akin to that produced by the 'Big Dichotomies' (Soja, 1989: 268) that run through Western philosophy and social theory: subject – object, abstract – concrete, agency – structure, real – imagined,

local – global, nature – culture, and such. Confined in such a way, the geographical imagination could never capture the experiential complexity, fullness and perhaps unknowable mystery of actually lived space, or what Lefebvre calls Spaces of Representation (Soja, 1989). So to break from the confines of binaries, there is the idea of a third ‘other’, an an-other which allows an alternative that both reconstitutes and expands upon the original opposition.

This idea is of course central to contemporary postcolonial thinking, and can be found in postmodern and poststructuralist writings as well. Drawing on Derridean deconstruction, this idea of a Thirdspace does not derive simply and sequentially from the original binary opposition and/ or contradiction, but seeks instead to disorder, deconstruct and tentatively reconstitute in a different form the entire dialectical sequence and logic. Anderson (2002), following Pile (1994) recognises the potential of the Thirdspace for mobilising place, politics and hybrid identities, which can,

‘facilitate new combinations of once dualized elements that augment and supplement knowledge production. By flexibly combining ideas, events, appearances and meanings, Thirdspace offers an epistemology that can respond to changing contexts’

(Anderson, 2002: 304)

This can then be ‘creatively open to redefinition and expansion in new directions’ (Soja, 1996: 2). This means we can begin to understand the possibilities of inhabiting this Thirdspace in the research, and understanding what occurs there in the Lived Space. For Bhabha it is possible to ‘elaborate [alternative] strategies of selfhood, [and] initiate new signs of identity’ (1994:1) from within the interstices, the hybrid positions that exist between the binary dualisms.

5. Conclusion: Space, Identity and the Liminal

Through the investigation of the ideas of the liminal, the liminoid, the Thirdspace of Soja and ideas of thirdspace found in Bhabha, this chapter has interrogated the idea of space and place. It has begun to display the theory to contend that space and identity must be understood not simply through ideas of history or the social

but instead in a trialectic of history – the social – and the spatial. As a way of doing this, the chapter has positioned the thesis in a place that draws on the liminal and liminoid. Returning to the opening quotes of the chapter, it is important to understand now how they can be read together. This chapter has developed an understanding of land, both abstractly and through recourse to Irish land and land issues which has lead theoretically to Soja, Shields, Hetherington and Anderson. In addition this chapter has positioned itself in a liminal position, informed by ideas from Bhabha, Turner and hooks. This is a space of change, a space of resistance and a space of alterity and through these ideas it is possible to understand how the issues concerning colonialism and postcolonialism need not be confined to the binaries and reductive discourses that have proliferated theories on Ireland and Irish identity. Instead, this thesis positions itself in a space where new identities and ideas are welcomed and embraced, and the problems associated with ideas of the colonial can be left behind in the hope of forging new sets of relationships and understandings of history. This space represents the fifth province that was first discussed in Chapter 1.

By tracing the liminal through the two lineages, it is shown how an understanding of this concept can provide an epistemological and cultural position from which empirical work on the Park can be conducted. The chapter began with a review of the different understandings of liminal, and the liminoid for Turner, and the main ideas associated with these that are important to this thesis, while at the same time problematising the inherent structuralism of this approach. The purpose of this section is to recognise that liminality is a theoretical position that allows for the undermining of solid and ‘authentic’ culture in favour of unexpected, hybrid and serendipitous culture. The chapter then moved onto the idea of mapping to demonstrate the relationship with land, not only in Ireland, but that is constantly present and the need to understand the complex processes that are involved in understanding spatialised theorising. The idea of spatiality is developed in the next section, where ideas from Lefebvre and Soja are invoked to discuss the importance of a spatial understanding of culture and the social. This highlights that marginal spaces are spaces for identity politics to occur, and that there are important social, historical and spatial considerations in any sociological understanding. This chapter informs the

empirical chapters by providing a theoretical basis for the approaches adopted there, while also informing the methods employed in the research, as discussed in the next chapter.

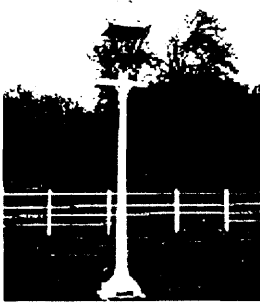

Chapter 4 Methods - In Media Res

'How can we know the dancer from the dance?'

(Yeats, 2000)

'Dancing in all its forms cannot be excluded from the curriculum of all noble education; dancing with the feet, with ideas, with words, and, need I add that one must also be able to dance with the pen?'

(Nietzsche, 1895)

1. Introduction

The above quotes relating to dance are important as a way of understanding the research process as used in this thesis. Drawing on Walkerdine (2002), the metaphor of a dance is employed to describe the relationship between the researcher and participant. This metaphor invokes the stages and procedures important for conducting qualitative social research. One must approach the participant and ask them to take part in a way which will be conducive to their agreement. During the dance you must take care to lead when appropriate and be led when also appropriate; the dance is a free form, though it is bound by structured rules which facilitate its occurrence, and it is a contextual event. There are different rules depending on with whom you dance, where you are dancing and what the purpose of the dance is. There is room for both people taking part to bring some of themselves to the dance, though this is a subjective, contextual self which will involve performance of the role that is being occupied. Everyone will dance slightly differently, but this does not detract from its beauty; it adds to and enhances it. There is a high level of interaction between the dancers, and this produces the meaning and understanding of the action. At the end of the dance, there is a memory and understanding that only those who participated have had, and any description or account will be partial and subjective. This chapter looks at the important methodological considerations symbolised through the use of this metaphor; it examines the relationship between insider-outsider researcher (Coffey, 1999), research methods in terms of how the reflexive process can enable theoretical development of the subject of study (Finlay, 2002) through the

act of positioning, and the ways in which poststructural and postcolonial theory cast the subject as multiple, dynamic and active in the meaning creation that occurs. The contextual importance of the research; where it happens, when and what is occurring in the vicinity are also important considerations.

This thesis uncovers the relevance of literary work for empirical inquiry, and the methods used must reflect the preoccupation with postcolonial theory. This means upholding the ideas and theories discussed in the previous chapters through the methodology and into the methods. The chapter is based around an idea of *In Media Res*, the meanings of which are discussed in the first section. The second focus is on the relationship between anthropology, and specifically ethnography, and postcolonialism historically and how this influences the methods used in current research. Having provided the justification and rationale behind the choice of methods, the third section provides a description of the methods used; the ‘hows’ of the research. This is followed by a section of vignettes which illustrate the issues discussed and how they emerged in practice, providing substantive examples of the methods and the way they relate to the theory.

2. Meaning *In Media Res*

The title of this chapter refers to two things that have informed the methodology adopted for this thesis. The first is the method of writing employed by James Joyce in *Ulyssus* and *Finnegan’s Wake*, books that are both situated in Dublin and have gone some way towards constructing contemporary Dublin cultural and literary scenes. It is appropriate to use this, as it constitutes a part of Dublin and Irish culture; and while it derives from a literary source it is applicable to the empirical as well, constituting an important theme in this thesis. *In Media Res* was a technique developed by Joyce initially in *Ulyssus* and then taken further in *Finnegan’s Wake*. It refers to the positioning of the reader and writer in or into the middle of a sequence of events that explicitly identifies the context spatially, temporally and culturally. What this does is insure that there is no one position which is privileged, no position which exists ‘outside’ the narrative and which can structure it in a manner that expresses ‘what really happened’. Rather than locating the subject in this viewpoint or punctum outside of the picture, from

which one can gain an overview and see one's own life experiences mapped out and used as the basis for making the assumption that all experience their subjectivity in the same way, now the reader as the subject, and also the writer as the subject are positioned within the perspectival position. The subject exists within the frame rather than outside it (Hetherington, 1998: 23)⁸. We are not positioned looking into the narrative(s), or given a vantage point but instead are *in media res*. Instead of proposing a view *on* the world, this thesis acknowledges its position as a point of view *in* it. This theoretical position, exemplified through Joyce's writing style, informs the methods and methodology used in this thesis. This chapter will begin by discussing this theoretically before outlining the practical application of the ideas through methods.

The epistemological assumptions contained in the thesis are closely aligned with the methodology associated with qualitative research. Being explicitly aware of methodological choices is of paramount importance in social science research, as choosing a certain methodology is tantamount to choosing an overall perspective which determines what a researcher will find. Thus, outlining an ontology and epistemology for the research is crucial. This chapter is compiled to demonstrate this before looking at the methods employed, so the methodology precedes the methods both in the chapter and in the thinking about the research.

The following section stresses the importance of subjectivity, and the manner of the work has been aimed at positioning the reader within the debates and theoretical context, while also developing a 'thick description' (Geertz, 1973: 5 - 6) of the Park itself. The ways in which theory and empirical inquiry have overlapped and developed, through an iterative, inductive approach, has facilitated new themes to emerge and alternative perspectives to contribute to the narrative of the work. The multi-method approach, coupled with a grounded theory method (Silverman, 2004; Glasner and Strauss, 1967) throughout, produced data that was consistent with the culture of the Park, and which was triangulated at different points and through continual reference with policy,

⁸ For this reason, through this chapter I have adopted the first person position which is avoided for the rest of the thesis. This was done on methodological grounds relating to subject position in postcolonial studies, and also as it makes the chapter immensely more readable.

historical and contemporary cultural documents allowed the positioning of statements in a broader position. Through the use of grounded theory methods there was a degree of verisimilitude ensuring that the data collected fits in with the way the participants regard the Park (Denzin, 1997). By aiming to achieve verisimilitude there is a conscious rejection of any attempts to obtain truth in an objective way, an issue which will be developed below. This can be understood in relation to subjectivity as specified above. The quest for the subjective self is linked to a rejection of ideas of ‘absolute truth’, as epitomised in the objective researcher. Qualitative research takes the researchers interaction with the field as an explicit part of knowledge production, and includes the subjectivities of the researcher and those being studied as part of the research process (Flick, 1998). This position is consistent with the ontological primacy central to postcolonial theory.

2.1 In Media Res - Subjective Selves

Identities exist within a paradoxical space in which there are no fixed centres and margins (Bhabha, 1994). This means that identities cannot be attached to singular uncomplicated subject positions (authors and narrators outside of the story), and identity becomes all about multiple locations and performativity within those locations. As such, identifications are multiple, overlapping and fractured. The adoption of this position is reinforced in not only the methodological considerations of this thesis but also in the theoretical work. The ethnographic project has had to undergo some critical self-examination and the historical figure of the male anthropologist, the anthropologist as bricoleur, the anthropologist who never questions where *he* stands *vis-à-vis his* interpretative community and the natives *he* writes about (Trinh, 1991: 72) was subjected to the most scrutiny. The shifting position of the social investigator, the sociologist and anthropologist, has been reinforced through the adoption of theoretical ideas aligned with poststructuralism. This project, initiated by the rejection of ‘grand’ narratives and structures, underpins this chapter and the theory found throughout the thesis. The ideas of identity in the empirical work have been developed through using the ideas found through the decentring work in poststructuralism, and developed using a postcolonial gaze. As Hetherington describes;

‘The theoretical decentring of the subject developing in poststructuralist analysis, alongside the pluralising and fracturing or layering of identities that has developed out of the identity politics of new social movements over the past three decades, is often seen less as an indication of marginalisation and oppression than as the basis for a politics of difference in which marginal identities become a source of empowerment and resistance’.

(Hetherington, 1998: 22)

The recognition that marginality produces empowered subjects capable of resisting the grand narratives or ideologies assigned to the social world of which they are marginal, has enabled the development of ideas of the liminal. The liminal spaces uncovered by Shields (1992) show the importance of those ‘Others’ in constructing the social world that is ‘Self’. The process of struggle, the ‘very act of agonism’ which produces these negotiations of identity, informs the ambivalent understanding of a culture which exists in society. However, it is not through the strict assignment of roles associated with modern society by which people construct this identity. Instead they are called upon to construct a narrative of identity that is not predetermined by tradition and custom, but which gives people the chance to write the script as they go along ‘even though some of the plot lines and sub-plots had been created within society’ (Hetherington, 1998: 23).

The interface between histories, culture, and language is a complex topology, it is impossible to read the narratives in a linear manner but instead they must be understood as rhizomatic, spiralling sets of ideas, linked together by spindling threads and complex webs (Deleuze, 2004). As with Foucault’s heterotopias⁹, there are many different complex relations that occur (see Chapter 3). The textual does not capture the entire ‘picture’; instead various things exist outside the traditional text of social research. The contextual elements of interviews, noise, facial expressions, gestures and scenery all impinge on the way the event occurs.

⁹ It is worth noting the importance of the Deleuzian extension of Foucault on this issue; as Foucault’s *Archaeology of Knowledge* implied strata issues of folding over are more readily dealt with by Deleuze and Guattari. The important point is that Foucault’s heterotopias lack a means of impacting on other ‘strata’, overcome to some extent by Deleuze and Guattari’s argument about multiple lines of flight; one place of immanence to many.

So, the second meaning of *In Media Res* that this chapter incorporates is a piece of artwork done by David Lilburn, an Irish artist based in Limerick, which follows on from and demonstrates the above ideas. He has constructed a work, based on *Ulysses* by Joyce, which presents these ideas in a beautiful visual manner. The work is constructed from a multiplicity of drawn marks and viewpoints, over seven plates and is a dense drypoint drawn map. As the artists describes it,

‘It is packed with references not only to spatial relationships, but also to (a fraction of) plot fragments, characters, land marks, anecdotes, quotes, conversations, historical references and classical allusions among others, mentioned or implicit in text for consideration; an opportunity to create a new orientation between you, the viewer, Dublin and James Joyce’s *Ulysses*’

The work is complex and overlapping, with some important monuments visible, while others are obscured by the overlapping words and phrases, the paths shown and the events which have occurred. It layers elements of contemporary Dublin on top of the Dublin of Joyce's time, allowing today’s Spire to shine right next to Nelson's Pillar that it replaced. Joyce himself appears in each of the maps, as an endearing little character in a purple suit. Art is a social endeavour, a living thing that extends beyond the textual and to understand it as such requires a reading which positions it within the social world from which it was produced. Lilburn produced this work as part of an exhibition on Joyce. Drawing on the previous chapters, this thesis occupies a position that identifies the colonial viewer as Euclidean emissary: the man who sits at Europe’s cartographic tables, who grids and tabulates, and who confirms his authority over foreign space through the power-technologies available to him. As such, we have become attuned to the provocation of post-modernity that ‘the map precedes the territory’ (Korzybski, 1931; Bateson, 1972; Baudrillard, 1994); that a certain highly mediated perception of space and sight constructs the colony in anticipatory prelude to its practical possession.

The thought behind the work by Lilburn demonstrates an awareness of poststructural ideas around identity, ideas found in the work of Joyce. His ‘stream of consciousness’ style of writing, also found in the work of Lawrence Stern, exemplifies the anti-traditionalist views expressed in the text itself. The

form has become as important in this instance as the content, an important aspect of the post-modern condition.

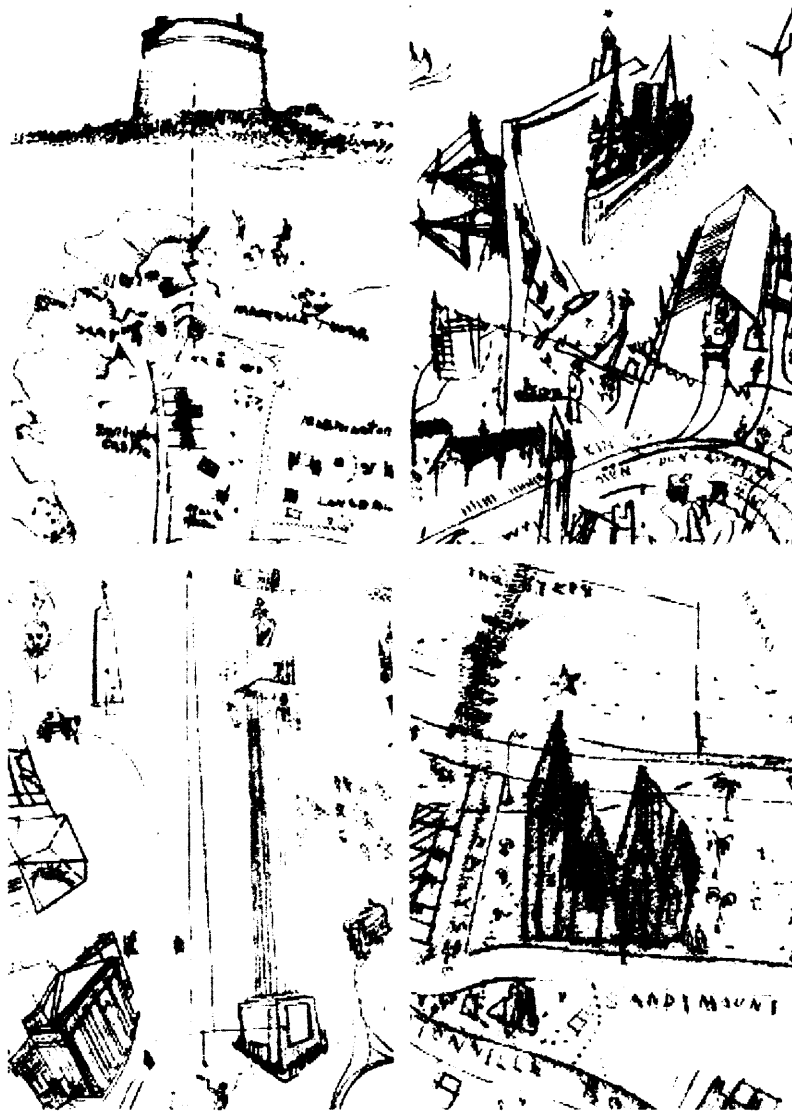

Picture 4.1 Extracts from *In Media Res*, by David Lilburn

The message is in the medium, the way in which the content is expressed is of equal importance as to what is actually expressed. This can be linked to a shift in anthropology, and notably ethnography, in theoretical emphasis from structure to process, from competence to performance (Turner, 1986: 21). This must involve positioning the subjective self into research through the recognition of the position of the researcher. This means developing a method of researching which shifts from providing a view on the world to a point of view in it (Dubow, 2000); an ontological positioning or situatedness.

2.2 Reflexivity: Negotiating Selfhood

‘If you would find yourself, look to the land you came from and to which you go.’
(Thoreau, 1995)

The issue of researcher’s subjectivity within the research process is another important element of this approach. As part of the ethnographic shift, it has often been highlighted that the researcher must recognise the importance of being reflexive, recognising their position within their own research. Beyond this, it is important to understand the production of the subjective self of the researcher itself (Walkerdine et al, 2002: 177). As Walkerdine et al (2002) emphasize, this process must include a recognition that research and subjectivity are co-produced through fiction and fantasy, and it is important to be aware that the issue of the narratives of the researcher and participant becomes more complex than the telling of different stories. Beyond a simple confessional, or expose on reflexivity, we must engage with how the intersections of competing facts and fictions are lived by the subject. A necessary part of this, Walkerdine et al (2002) argue is the recognition of emotions within the process. The ‘dance’ that occurs between researchers and researched to produce the ‘data’ must be understood with recourse to ideas of fantasy, desire, anxiety, affect and defences. However, embarking on reflexivity is akin to entering uncertain terrain where solid ground can all too easily give way to swamp and mire (Finlay, 2002: 212). This means I do not engage in some form of self-analysis that deteriorates into an opportunity to wallow in subjectivity or provide an opportunity to engage in legitimised over-emoting.

The engagement with ideas of national identity is always complex, and in Ireland there are continual reminders about what happens when national and religious identity is inflexible and resistant to change, with the Northern Ireland situation. In the south of Ireland this has lead, particularly in affluent Dublin, to a sort of post-Nationalism, a renouncement of these concerns which would interfere with some sort of European, global, well-off identity. However, there is a residual caution about talking about ideas of national identity, something exacerbated if the interviewer is not Irish. While I grew up in Southern Ireland, in Limerick, both my parents are from Northern Ireland and the combination of accents has

lead to me having a very soft southern Irish accent, one that is often perceived as English by Irish people, despite having never lived in England. During the interview phase of my research, it was common for people to ask me where I was from in England, and when I said I was Irish some expressed shock and disbelief. In addition to my accent, the subject matter I was enquiring after may have increased people's suspicions and encouraged them to probe. It may have inhibited people from expressing strong or even moderate nationalist views if they felt I would be offended or hold an alternative view.

In Northern Ireland, there has been work done on the process of 'telling' (see for example Finlay, 1999), a means of identifying the ethnicity¹⁰ of the person with whom they are engaging. This process is used to bypass sensitive subjects and avoid the possibility of escalation into violence or aggression. In the context of this research, the outcome would not be expected to be violence, though riots in Dublin in March 2006 have demonstrated that there are still high emotions around these subjects within certain groups, but there would be the possibility of offence or, worse, of being portrayed as backward looking and traditional. Ireland has embraced modernity with such fervour, and Dublin especially, that to be projected in a traditional way, as embracing ideas associated with the past, would be highly stigmatised.

Therefore, as part of this chapter, I am going to provide something more, I hope, than a simple confessional, but instead I will attempt to engage with the emotions and feelings about Ireland, growing up there and interactions regarding national identity. It is important to recognise my multiple subjectivities; as an academic, as an Irish woman, as a Northerner at birth, to living in Southern Ireland and attending university there, and as a person who no longer lives in Ireland. All of these things, and more, come together to form the self I will have used when conducting research and interacting with participants. In addition, I have idea(l)s about Ireland and Dublin to which I am returning, both metaphorically and materially, with this thesis. I am interested in national identity in Ireland as someone who has fallen outside of the normal boundaries, and so to engage with

¹⁰ In the case of Northern Ireland, I use this to refer to religious and/or political affiliations.

it means engaging with preconceptions and issues which form who I am as this researcher. This is one of the reasons why this topic appealed to me, as I was interested to see how well ideas of postcolonialism provided me with a framework of understanding for the different experiences people have in contemporary Ireland. So, engaging with these issues means reflexivity is about exploring the dynamics of the researcher and researched, examining one's own relations with the topic and the methodology employed and focusing on how the research is co-constituted and socially situated; positioning the dancers in the context of the dance and understanding the relationship between them.

For Said (1994), the 'world' from which the text originated, also understood as the world with which it was affiliated, is crucial. The materiality, the locatedness, the worldliness of the text is embedded in it as a function of its very being. It has a material presence, a cultural and social history, a political and even an economic being (Haraway, 1990: 111). By bringing together the word, the text and the critic, it is possible to highlight their affiliation. This means that the text is crucial in the way we 'have' a world, but the world exists as the text's location, and that worldliness is constructed within the text. The text does not exist outside the world but is a part of the world of which it speaks, and this worldliness is itself present in the text as a part of its formation. This relates back to ideas of subjectivity already expressed using the idea of *in media res*, but Said's idea of worldliness extends this to incorporate the reader, or critic of a text. By recognising that the text exists as a material object, produced by its position, the position of the producer and the position of the consumer, we begin to unpack the meaning associated with a text.

3. Postcolonialism and Anthropology

In basic terms ethnography is the practice of anthropological research based on direct observation of and reportage on a people's way of life. Its place in postcolonial studies has not always been straightforward, and has on some level contributed to the discipline's inherent colonial assumptions. The discipline of anthropology has complex intellectual roots in the Enlightenment and the European discoveries of non-western peoples (Barfield, 2001). Along with disciplines such as geography, the aim of anthropology was to map out and chart

the 'other' in a manner which made it known, and concurrently derogated and strange. Inherently linked with this is a claim to objectivity, altruistic and philanthropic work that is tied to bettering this un-cultured other. Ethnography was bound to the colonial project for most of the 17th, 18th, and 19th century, with the ethnographers fostering a colonial pluralism that left natives on their own as long as their leaders could be co-opted by the colonial administration (Denzin and Lincoln, 2000: 11). The researchers were influenced by the political hopes and ideologies, discovering findings in their research that confirmed and reinforced prior held theories or beliefs, justifying the actions that their governments or civil servants were committing in the name of progress. For Denzin and Lincoln (2000) this represents the 'Traditional Period' of ethnography, based on 'objective' colonialising accounts of field experience that were 'reflective of the positivist scientist paradigm' (2000: 12). The Lone Ethnographer subjected himself (predominantly male, with the noted exception of Margaret Mead) to extended time in the field, distanced from the 'culture' and 'comfort' of home. They felt they were producing something that was timeless and monumentalist, but instead the body of work has come to be regarded as a relic from a colonial past they helped to create.

This chapter diverges to discuss a history of anthropology at this point as it provides the historical context out of which the methods adopted are found. The ethnographic methods found in this thesis are linked through theorists and previous research to the colonising process, and as such ambivalence emerges around the adoption of this approach. Using a historically colonial method to look at a postcolonial space may raise issues around representation, legitimation and praxis, and this historical account of anthropology is used to contextualise the following section which deals with these issues.

Within the two hundred years of history of the human sciences, the denotations of the word ethnography have shifted several times. According to Barfield 'the English scholars who took these words up from the 1830's onwards seem to have de-emphasised the geographic and linguistic aspect of ethnological and ethnographic inquiry in favour of a study of racial origins' (Barfield, 2001) Historically, ethnography concerned itself mainly with recording the habits and

life of people from different societies, 'usually distant locales, distant that is geographically or culturally from the west and seen as different from the normative European cultures' (Ashcroft et al, 2003: 85). James Prichard's *Researches into the Physical History of Mankind* (1813) was the first prominent work in English to deal primarily with ethnology. For Prichard ethnology and hence the practice of ethnography, aimed 'to trace the history of the tribes and races of men from the remotest periods which are within the reach of investigation, to discover their mutual relations and to arrive at conclusion, either certain or probable, as to their affinity or diversity of origin' (Pritchard, 1973: 231). Prichard's idea of ethnology as a reconstruction of racial history and human origins survived into the early twentieth century.

By the 1860's with the rise of Darwin and the evolutionists, anthropology and therefore ethnography became more concerned with tracing the progressive development of society. As the nineteenth century progressed, anthropological inquiry began to focus on evolutionary questions. The need for better data became clear. In 1843 Prichard and two of his colleagues drew up a schedule of questions to guide observations of native peoples (Penniman, 1935: 53). Lewis Henry Morgan began sending his first kinship terminology questionnaires to missionaries and agents in January 1859 (Penniman, 1935: 54). The relationship between colonialism and anthropology was established through this practice, and reinforced in the epistemology which underpinned the discipline as a whole. Looking at these indigenous peoples through a Darwinian lens was clearly useful to colonial discourse in constructing a cultural hierarchy, which later helped to justify the colonisation on a mass scale of a number of countries by supplying the moral legitimacy.

This chapter has already highlighted the problems associated with ideas of neutrality and objectivity and these issues are found arising in contemporary ethnographic inquiry, which links sociology and anthropology. Ashcroft (2003) highlights the point this chapter aims to present, that knowledge depends upon how it is known and that cultural knowledge is 'constructed' rather than 'discovered' by ethnography. James Clifford (1988) insists that ethnography is essentially a form of writing and should be approached from the point of view of

its textuality. According to this approach, following the demise of colonialism 'the West can no longer present itself as the unique purveyor of anthropological knowledge about others' (Clifford, 1988: 22). However, the most forceful criticism of ethnography suggests that it has existed precisely to place the observed in a specific way, as Europe's 'Other' (as Geertz, 2000: 95 observes 'inevitably capitalised, inevitably singular').

According to Barfield (2001) anthropology is inseparable from the history and practices of colonialism in a double sense. First, anthropologists were frequently in the employ of the colonial state itself and second, the science of race and of races was an integral part of the ways in which colonial powers represented themselves and non-European others in the nineteenth and twentieth century. It is with the tensions and contradictions within various colonial projects that much recent anthropological work has concerned itself. Richard Fardon writes,

'Anthropology necessarily reproduced versions of assumptions deeply embedded in a predatory European culture...to counterpose to an enlightened Europe, we produced an African heart of darkness; to our rational, controlled west corresponded an irrational and sensuous Orient; our progressive civilization differed from the historical cul-de-sacs into which Oriental despots led their subjects.'

(Fardon, 1995: 3)

The idea of colonisation goes beyond the spatial, and occurs within the mind (Kiberd, 1995; Fanon, 1961; Berger and Luckmann, 1967). There are a number of intrinsic assumptions that occur in Western thinking that are (re)produced, and reinforced, through ideas of the colonial. As already discussed, ideas of binaries are fundamental to this process of thinking. These can include things like insider/ outsider; self/ other; good/ bad; civilisation/ barbarians; occident/ orient. As part of these binaries is a moral assumption about which one is 'better'. This has been one of the underlying rationales of colonisation, the idea that the coloniser has something which it can 'give' to the colonised – civilisation, education, religion or simply culture. Of course, this is paralleled with the economic exploitation that occurs, which has been well documented elsewhere.

Postcolonial studies, and this thesis, aims to go beyond these binaries, to examine the liminal, the hybrid and the areas of ambivalence that exist. This is not simply

on a cultural level, or a material level - both of which have previously been discussed, but also on the epistemological level, which underlies and determines it all. In this sense then, like poststructuralism, postcolonialism aims to 'break free' from the structures and modes of thought that we operate through. Indeed, the anthropological roots of certain approaches within sociology means that it is a discipline embedded in the colonial tradition – assuming certain traits which are aligned with the ideas of 'Western thought', and embodying the presumptions which go along with this. This informs issues around the involvement of anthropological research with colonial regimes around the heyday of Western Imperialism, and indeed with its aftershadows now. Reinforcing this are accusations from post-colonial intellectuals about the field's 'complicity in the division of humanity into those who know and decide, and those who are known and decided for' (Geertz, 2000: 95). This view, that the anthropologist regards themselves as the native's friend, and still think they understand them better than they understand themselves has troubling implications for methods and methodology.

The crisis surrounding the discipline of anthropology as a result of these criticisms has prompted a major epistemological and ontological shift in the way anthropology and, concurrently, sociology is conducted. Is there a place for anthropology and if so how can it reconcile its difficult past with the tenets of colonialism? Clifford (1988) suggests that there is a need for a form of ethnographic writing that not only takes into account but also overcomes its colonial history. There are several strands to this anthropological re-reading of colonialism. First it has the ability to reclaim the lost voices, the silences of the imperial record, of the struggles and resistances of subaltern groups. Second to recognize the reclamation of such subalterity is to position colonial hegemony into a different light. Colonialism must be recorded and understood as one of the processes through which the world has been shaped, and post-colonial empirical work must recognise this using a methodology which is sympathetic to these processes and cultural developments. Indeed, Geertz (2000) draws a similar methodological conclusion, and proposes that we begin to recognise a movement towards researching 'others' (uncapitalised and plural), in the manner 'that they go among themselves, ad hoc and groping' (2000: 96). *In media res*, as a

methodology which is informed by a wide range of theorists and cultural commentators who are in tune with this (for example Trinh, 1992; Denzin, 1997; Eagleton, 2004; Dubow, 2000; Gubrium, 2000), is sympathetic to this, and aims to respond to the cultural instances when remnants and processes of colonialism are evident.

3.1 Where do we go from here?

And so we enter the sixth moment¹¹ of ethnography (Denzin, 1997), an engagement with the ‘triple crisis of representation, legitimation and praxis’ (Denzin, 1997: 3) that has engulfed qualitative research in the human disciplines. Associated with the postmodern, poststructuralist and postcolonial critiques which have developed feminist and linguistic theoretical developments the main tenets of these arguments have been rehearsed in this chapter already. To summarise the issues presented in this chapter, before moving into a practical account of these issues, I use Denzin’s triad of issues; representation, legitimation and praxis.

The first, representation, confronts the problem of how the researcher presents the ‘findings’ in a manner which recognises that their product is a narrative production. It calls for a movement away from the idea that there is a ‘knowing’ author who can step outside of the world they are researching, and simply reflect, like a mirror, this world for the rest of us to see. However, through this process it is imperative to recognise that the subject is being acted upon in one of two ways (or both). The subject is translated into ‘an analytic subject as a social type or a textual subject who speaks from the author’s pages’ (Denzin, 2000: 5). This places the subject in a particularly difficult position for qualitative analysis, as it removes them from their position of subject to one of object, the researched become an object of inquiry; voiceless except through the researcher; created, not through their own language and speech but through that of the researchers; and frozen in time and space. And so an awareness of this must be held; awareness that there can never be a final, accurate representation of what was said or meant,

¹¹ Denzin (2000) describes the Traditional Period, Modernist Phase, Blurred Genre, Crisis of Representation and Fifth Moment as coming before the phase we are entering in ethnography, which is still undefined. In Denzin and Lincoln (2000) instead of the Fifth moment, there are Triple Crisis and Reading History. These correspond in meaning.



‘only different textual representations of different experiences’ (Denzin, 2000: 5).

The second pillar of this critique is the crisis of legitimacy. Any recourse to ideas of validity in social research usually gathers around ideas of objectivity and the removal of researcher bias. The quest for internal, external and ecological validity is more often now confined to the corridors of quantitative inquiry. Ideas associated with them are linked with issues of author(ity), a position which allows description of the ‘reality’ of social life. As such, ideas of validity must be recognised as holding a powerful and influential position, which legitimates that which should and should not be included. As Lather describes, ‘validity is the researcher’s mask of authority’ (Lather, 1993: 674), that allows a particular regime of truth to be developed and presented within a text. The way that this research overcomes this potentially inescapable dilemma is by understanding that the interviews and observing that occurred produce particular, situated understandings and readings of what is occurring. The understanding that is reached about the research is determined by the critical understandings that are produced, the product is contingent and significant because of this, it is based on an instance of cultural practice that happened in a particular time and place and which cannot be generalised to other practices; ‘its importance lies in the fact that it instantiates a cultural practice, a cultural performance (story telling) and a set of shifting conflicting cultural meanings’ (Fiske, 1994: 195). So this research has aimed to,

‘Find out the typical ways of thinking and feeling, corresponding to the institutions and culture of a given community and formulate the results in the most convincing way’.

(Denzin, 1997: xvi)

It has done so with recourse to ideas of verisimilitude, the idea that it should appear true, and be based on an agreed-on position between the researcher and participant, it must conform to and present the laws of engagement, the relationship and the negotiation as it occurred. It must also have verisimilitude for the academic audience to which it is presented, and as such the laws of this genre must be withheld for the thesis to be accepted and acceptable. Of course, the truth of a text cannot be established by its verisimilitude as verisimilitude can

always be challenged, as texts are always a site of struggle over the real and its meanings.

The issue of praxis and how the issues above can be transformed into a workable, useable method is an important prerequisite for their adoption. It is imperative that the poststructural and postmodern 'turns' do not reduce methods to a 'free for all' where everything is acceptable, and there is no regulation as there is no recourse to ideas of validity and replication. Instead, there must be a way found which encompasses the training and expertise of the social scientist in research methods, but does not 'write' the subject out of the transcripts. The methods must incorporate and appreciate the different realities and context of the research, recognising the place of the researcher within the process. A return to the opening metaphor of the dance can be brought back now, as a way of engaging with the theoretical considerations highlighted above.

4. Methods Used

In this section, I describe the methods used in the thesis. This is followed by a number of vignettes around method to emphasise the theory expounded above and throughout this work. I adopted the ethnographic triptych of observation, interviews and documentary analysis to develop an understanding of the Park, and the history of it as perceived by the producers and consumers of its culture. A research diary, documenting thoughts and feelings as well as field notes, summaries of interviews and accounts of events in the Park was kept throughout the research process. This diary was very valuable in the research, as a way of organising my thoughts and aiding the analysis.

The primary method of data collection I employed in this research was observation; I spent long periods of time walking around the Park to make sure I got a sense of the different uses and attractions at different times. It should be noted that these visits were almost entirely carried out on foot, but the two times I went by car the Park seemed quite different. It was the data collected through walking that was richer, thicker and more in touch with the Park and the activities I encountered during the walk. I visited the Park more than ten times over the course of two years, and on each occasion spent five or six hours there.

During these visits I would take photographs, talk to people casually and go to the Visitor Centre. Through different ways, I gained access to different levels of management associated with the Park, who participated in the research. I also interviewed a number of visitors to the Park, locating myself at different strategic points, for three sessions of three hours, interviewing whoever came along the paths. This meant that the sights, sounds and smells of the Park were present during all the interviews. All people interviewed were asked if they wanted to remain anonymous and were assured that the data would be kept confidential. I asked if it was alright to record the interviews, and described how the data would be used. They were aware of the reason behind the research, and I gave them contact details in case they wished to follow up anything or contact me. I worked according to the British Sociological Association ethical guidelines, the Economic and Social Research Council ethical guidelines and the ethical guidelines provided by Cardiff University.

I used documents¹², both contemporary and historic, to discover events and occasions which occurred in the Park, and the ways in which they were perceived through the narrative which presented them. This was achieved by using a narrative analysis of the documents, reading them as texts produced with meaning and context and situated within specific cultural and social events. I aimed to find multiple accounts on each event, and used documents to position the Park in its historical context. This was concurrent with the rest of my methodology.

4.1 Interviews

Interviews were the main method through which I had contact with the management and visitors to the Park. Famously, Silverman (1993) described ours as an 'interview society', where the mass media, service providers, daytime talk shows, researchers, newspapers, magazines and everything else rely on the interview to transmit and/or collect information. However, the interview is not as straightforward as the extent of this coverage and use may suggest. When it is understood as something more than simply data acquisition it becomes a

¹² These include newspapers, historical accounts of Dublin and the Park, contemporary policy documents, OPW accounts, maps, pictures and the signs up around the Park.

complex sea of narratives to be deciphered and interpreted in different ways, a 'window on the world' that only lets us see certain things and in specific ways. The conventional view of an interview as a 'pipeline for transmitting knowledge' (Holstein and Gubrium, 2002: 112) has been problematised through the 'recent heightened sensitivity to representational matters' (Holstein and Gubrium, 2002:112), as brought about by poststructuralism, postmodernity and constructionist inquiry. These are the issues that have been brought to the fore in this chapter, and the questions about how these issues translate into methods that can be used is the focus of this section.

A necessary starting point is to acknowledge that the interview process shapes the form and content of what is said. Both the respondent and the interviewer are active participants in the construction of meaning, meaning which is actively and communicatively assembled in the interview encounter. Through this understanding, we can begin to recognise that the interview is a site of collaborative knowledge production, produced through the relationship between interviewer and participant, the place and time it is taking place, how the interaction has occurred and a number of other factors. So, to move forward towards a methods which recognises this, calls for the acknowledgement and adoption of 'consciously and conscientiously attending to the interview process and its product in ways that are more sensitive to the social production of knowledge' (Holstein and Gubrium, 2002: 113). Within this approach, the process of meaning production is as important as the meaning that is produced (Berger and Luckmann, 1967), and so it involves being sensitive to the interactional and narrative procedures of knowledge production, and not merely to the interview technique. As such the metaphor of the dance becomes evident and transparent.

During the interviews conducted, I was conscious of the introduction of etic language and phrases, such as 'postcolonialism' or 'liminal', which the participant would not use naturally. I did not want to influence the participant in such a manner, and used words relating to themes I wished to develop only once the participant had introduced them. The interviews with people at management level and in the Office of Public Works moved towards being a mutual

collaboration, and essentially the participants became co-researchers. This emerged as they were more knowledgeable about the Park than I was, having spent more time there, and engaged critically with some of the issues I was interested in. This meant that a reflexive dialogue emerged encompassing personal accounts, viewpoints and feelings on important themes. These were investigated through a collaborative, democratic process, whereby we engaged with and investigated the issues at hand. This led to 'active interviewing', a method discussed below.

4.2 Active Interviewing

Ideas relating to neutrality of the interviewer, validity because of the removal of 'contamination' from researcher bias and poor questioning technique are all dispelled in this methodology as issues which do not relate to the interview process which is occurring; these are aspirations associated with a different epistemology, a set of doctrines which are paradoxical within this mode of thinking and praxis. Only from a narrow view of interpretative practice and meaning construction can the issue of bias emerge within interviews, as interviews are sites of interpretative practice they are never 'pure' or uncontaminated, but instead products of the relationship between participant and interviewer (amongst other things). The role of the interviewer, and the role I adopted in all interviews, follows the idea of an 'active' interviewer (Holstein and Gubrium, 2002). According to this approach, the interviewer aims to incite respondents answers, 'virtually activating narrative production' (Holstein and Gubrium, 2002: 121) through 'intentionally provoking responses by indicating, even suggesting, narrative positions, resources, orientations and precedents' (2002:121). This 'active' view eschews the image of the interviewee as a vessel waiting to be tapped, in favour of the notion that the subject's interpretative capabilities must be activated, stimulated and cultivated. Meaning is actively and co-communicatively assembled in the interview encounter, and as such it must be understood that interview data is unavoidably collaborative. This moves the subject into an active position, away from the 'vessel' idea, in which the subject is epistemologically passive; not engaged with the production of knowledge. They act as co-researchers, engaging with the issues and tackling the

themes via dialogical interaction with the researcher. This occurred simultaneously during the interviews with management and with the resident.

This idea has clear resonance with the ideas expounded in previous discussions on postcolonial theory. The idea of a passive, voiceless subject who does not participate in meaning making or interpretative processes related to their position in society, or more widely the coloniser/ colonised relationship has been dismissed and questioned through this thesis. The importance of relating this to the methodological position, and this being communicated through the methods was a crucial project with the work, and has been achieved through this adoption of 'active' methods of data collection, where the participant is viewed as an active meaning making subject. The manner of interview has reflected this position; ranging from semi- to un-structured interviews depending on the participant. With the management and OPW officials, there were certain themes I specifically wished them to address, and the interview was steered towards this. In the interviews with visitors and the resident, it was unstructured apart from an initial question which asked them to describe their relationship with the Park (these were phrased differently across the interviews depending on the context; for example, visitors could be asked why they were in the Park, or why they first started coming to the Park).

4.3 Questionnaire

Another component of this research was a questionnaire distributed to the residents of the Park, and there were twelve returned out of 32 sent out. This method was employed as the residents were predominantly elderly and in consultation with the Park management contacting them by post was seen as the best means, and I included a self addressed, stamped envelope for their replies. The age of the potential respondents can also be used to explain the low response rate. This method removes the researcher (physically) from the point of data collection, and is obviously problematic for this idea of 'active' researching. The questionnaire (see Appendix 4) was themed around issues which I anticipated to be important based on the documentary and historical research I had already conducted. The questions were open and facilitated many different manners of response, which could be personal or more focused on the Park, historical or

contemporary, and positive or negative. So while I was not there to actively enable narrative production, in the constraints of the questionnaire I aimed to achieve a similar means of interaction with the participants. By leaving the questions as 'open' as possible, I aimed to allow the participants as active a voice as the questionnaire format would allow. They were coded using a code and retrieve system, working through each document and recognising the emergent themes, and colour coding them. These themes were then matched across all the questionnaires, and linked to the emergent themes in the interview analysis. The questionnaire data is used in a similar way to the interview data; specific quotes are used through the analysis to signify themes.

4.4 Analysis

Analysis is a 'pervasive activity throughout the life of a research project, not simply one of the later stages of research, to be followed by an equally separate phase of 'writing up' (Coffey and Atkinson, 1996: 10 – 11). This was very much the approach adopted in this thesis, and analysis was continually occurring and being revised. From my initial visit to Phoenix Park the analysis of the research site began, and there was a continual reference back to previous data and experiences throughout the process. This allowed a balance between focused exploration, relating to postcolonial theory, and an (attempted) open-mindedness towards the data through continual reference to empirical work as the theoretical work continued.

The method of analysis is as important a consideration as the means of data collection, and it was a recognition of the 'hows' and 'whys' of the interview though also of the 'whys' and 'whens', which were important for this research. I was interested in the way people projected themselves and their relationship with the Park, but also need to acquire knowledge about the Park and the structures in place. Discursively, this means an awareness of contemporary events framing interview accounts as single time point events. With the interviews with the visitors, it was far more about how they projected themselves and their relationship with the Park, a far more personal subjective account, which allowed for more interrogation around the interactional aspects. This is something which has been noted previously in the chapter; the way people responded when they

thought I was from the UK, and the way they responded when they knew I was from Limerick. This is one of the stark aspects they might have responded to, and there were undoubtedly many more.

The analysis performed composed of code-and-retrieve methods, where the interviews, documents and observational data were read and re-read to insure an awareness of the different themes and how they developed within the accounts. Themes were identified and coding began. This process was done manually, favouring this over the employment of CAQDAS. Through the constant working with the texts a greater familiarity is developed, and since there was a workable amount of data it was more appropriate for this research. The focus was on emergent ideas and cultural signifiers, which often did not have words or phrases in common but were linked by a cultural reference or historical understanding. For example, participants would refer to events in history by raising different issues or methods of description; so while it would be possible to code something like 'Pope's Visit' it would not describe the different attitudes towards it or reasons people were evoking it. The themes relating to postcolonialism were never described in a way that could be coded; nobody described Phoenix Park as liminal or hybrid in their interviews, but instead used imagery and description that meant it could be understood as such. The cultural significance that people understood by the different events and the underlying understanding they held of these events was what was themed, rather than the specific events themselves. This meant that a high level of familiarity with the texts, developed through reading and re-reading, was the most important aspect of the analysis.

5. Vignettes around Method: Traversing Theory and Praxis

The stories below recount the different issues that arose around the gathering of data, and vignettes are used to discuss certain areas that are important in the 'active' interviewing and researching that I endeavoured to perform. This section introduces the empirical elements to the theoretical discussions of the issues above. It highlights the problems and solutions found, and the ways in which as a researcher I engaged with them.

5.1 Access

The advantage of doing research in a public park is that the observational component of the research was not difficult. Access to the Park during the day was completely unproblematic, and could be carried out on foot. This allowed me to explore and discover different areas of the Park at different times, and at a walking pace, which meant reflection and contemplation were on-going during this time. It was a time when I took photographs for the thesis, and gained a deep appreciation of the beauty and tranquillity of the space, and the importance it holds for many people. Like a researcher who gets to know their participants following long stints of fieldwork, I grew to know the Park and looked forward to returning to it as much as I disliked leaving it.

As is often the case, gaining access for the interviews proved more difficult than first anticipated. There was a distinct lack of clarity around issues of management, and to whom it would be possible to speak, exacerbated initially by an untrusting gatekeeper, the receptionist/ guide of the Visitor Centre. Unconvinced of my legitimacy, he was reluctant to provide any contact details with either the Visitor Centre or someone in management within the Park. Using the internet, I discovered the email address of the Visitor Centre and contacted them again, following my initial visit, and told them about the research. The email was returned as I had used the internet email address which was still affiliated to Duchas, whereas the Centre was now run by the Office of Public Works. Having resent the email to the correct address I received no reply. However, at the same time, I had contacted the OPW directly, through their library service, and the Head Librarian had forwarded my inquiry over to the Visitor Centre. I received a reply from the Librarian concerning the architects of the Centre, and was informed that they had already been contacted on my behalf. This was an excellent, serendipitous step, and subsequently proved one of the most valuable sources of data.

I decided to ring the Visitor Centre directly, and asked to speak to the manager. The manager would not talk to me, and instead told me to phone the Visitor Services Head Office of the OPW. This change of direction proved useful, as the person I spoke to in this office was able to contact the Head Guide of the Visitor

Centre and arrange a time when she would be at the Centre and available to talk. I booked flights and organised it so that I would be there when she was. On arriving at the Centre for this arranged meeting, she was not there, and the receptionist/ gatekeeper was again reluctant to contact her on my behalf. Resigned to not meeting her, I went into the Centre and began documenting and photographing each of the displays. After about an hour of being there, the receptionist approached me once again, and gave me the direct line to the Centre's reception, and told me to call and find out if the Head Guide was there before I came the next time. We stood and talked about the Park, and he was clearly passionate about the history, and so we spoke about that aspect. He told me how he had walked around the boundary wall of the Park, all seven miles of it, and that the Park was something for Dublin and Ireland to be proud of. After this talk, I felt I was established within the Centre, and that he would help me to gain access and conduct research. I expressed an eagerness to interview him, but he shrugged it off saying I should only speak to the Head Guide. However, we spoke for another ten minutes and I gained his approval to use what he had said as data.

I was unable to make contact with the Head Guide on that visit, though on the following trip it was possible, and we arranged to meet. When I got to the Centre this time, she was there but unable to stay as she had a meeting. However she arranged for me to go to Whitefields, a building with offices, a canteen for the Rangers, and a committee room within the Park. This building was where the Chief Superintendent of the Park was based. One of the Rangers came and picked me up from the Centre and took me to Whitefields, and on the way I conducted an informal interview as he had grown up in the Park in a Lodge that 'was a police station when the British were, when they left my father moved in'. He was friendly and eager to tell stories about the Park, and became one of my resident participants. In Whitefields, I was going to speak to one of the grounds keepers but he too was busy, and so I ended up speaking to the secretary there. She was friendly and informative, giving me email addresses for the Superintendent and the best ways of contacting her and arranging an interview. She also gave me the number of the Press Officer for the Office of Public Works responsible for the Phoenix Park, and a contact name in Áras an Uachtarain. As

such, I snowballed through the contact network that unfolded from the ‘producer’ site within the Park.

5.2 Interviewing the Head Guide

The next visit was centred on the Head Guide, who I finally met with in the Visitor Centre. When I arrived, she apologised for the previous behaviour of the receptionist/ gatekeeper¹³, and introduced me to the other guides. The interview went well, and the Head Guide was interested and interesting in talking about the Park, the history, her own experiences of life around it, and her position in relation to the Park and the Park’s management structure. She had recently completed a MA in history, and had used the Park as the site for her dissertation, which meant that she had engaged with it on many levels; as tour guide, as worker, as researcher, as historian. Her knowledge cast her as a co-researcher during the interview, and we discussed theoretical issues relating to the Park, including detailed history in a collaborative manner. As with all the interviews, I recorded it using a minidisk player, and took notes. I worked from an interview schedule rather than a set of questions, which aimed to direct the interview towards the main themes I was interested in, while allowing the participant to develop the interview in any way they desired.

5.3 Interviewing the OPW – the Personal is the Park

From another access route, through the Office of Public Works, I was able to arrange an interview with the architect of the Visitor Centre. This interview was conducted in the OPW head offices in Dublin, and lasted over one and a half hours. Since Garfinkel and his ‘breaching experiments’ in the 1960s there has been the recognition that incidents or events that disrupt the social, offer opportunities to expose the normally hidden moral or social orders. The dispute that the architect had over the design of the Visitor Centre was a crucial means of illuminating the underlying ideologies and philosophies in the management of the Phoenix Park, and the Chief Superintendent at the time specifically. The account the architect gave of this dispute facilitated the emergence of some of the main themes found throughout the work, and informed the direction of

¹³ She apologised for him being ‘so rude’ in our previous encounters, and said that it was just his ‘nature’.

subsequent interviews. The identification of boundaries within the social sphere, where everyone was supposedly working for the 'best of the Park', allowed for the identification of what different people took for granted, and where they were embedded ideologically and with regard to conservation. The next interview, with the Press Officer in the OPW responsible for the Park provided an interesting account which illuminated this aspect through the desire to situate the Park within the wider Dublin and Irish context. However, when the interview was 'finished', and the recorder stopped, he returned to a more personal perspective focusing on personal stories about the Park and friends.

The bifurcation between 'official' and 'personal' accounts is something that few people interviewed expressed, particularly the Chief Superintendent, who regarded the personal and professional ties to the Park as synonymous with each other. This was a result of the relationship people held with the Park, and the way their life and work became engaged with each other through the site. This was really exemplified with the Rangers who lived in the lodges around the Park, or the retired Rangers who had spent most of their life living in the Park. Their ontological being was so intimately tied to the space that their epistemology was totally linked with it as well. It was this which inspired the manner of methodology which was adopted, in an attempt to express and understand this relationship.

The interview with the Chief Superintendent exemplified this on a number of levels. The meeting began with lunch at the Visitor Centre, where an artist joined us who used wood from the Park and produced sculptures with it which were displayed around the grounds. The conversation was conducted at a personal level, the two men knew each other well, though was intertwined with references to the Park and the work the artist did. The context of their friendship was the Park, and the conversations we had focused on it spatially and culturally. Following this, the more 'formal' interview began and the artist left. It involved a continuation of the discussions over lunch, with some more 'facts' about the Park inserted. It also provided a chance for clarification over issues relating to the Park and its history. The Chief Superintendent was completing a PhD on the

history of the Park's layout and flora, and was able to provide useful information about this.

Throughout all these interviews, the attitude towards my research was supportive and interested. The participants were thoughtful and informed which made the interviews enjoyable and relaxed, which facilitated the methodology I adopted. They were happy to share and disclose personal stories and information about their relationship with the Park, and to share all they knew about it in a professional manner.

5.4 Meeting the Residents

During this period of research, I became aware that a number of the residents of the Park were quite elderly, generally above seventy. Through discussions with the main secretary of the Park it was decided that I should initially establish contact through the post, and establish people to interview through this. I sent all the residents a letter, an open questionnaire and an invitation to participate in a follow up interview. I enclosed a stamp-address envelope, my telephone number and email address and an outline of what the research entailed (Appendix 4). The response I received from the questionnaires was good, with eight respondents who gave full and interesting answers, which elaborated well on points that were important to the residents, and developed interesting links between the questions asked. In addition, I received two potential interview candidates, and arranged to meet them and talk to them. When I arrived in Dublin, one of the potential participants was sick, and did not want me to come to her house, and was subsequently unwilling to participate. The other participant welcomed me into his home and provided a long, comprehensive and interesting account of his time in the Park from being a young boy who grew up there, to being a man who worked there as a Gate Keeper and Ranger, to an old man who was enjoying the beauty and tranquillity of the Park and the memories of raising a family and enjoying a marriage in the Park. Jim was *au fait* with talking about the Park¹⁴, and had many old photographs which illustrated his stories beautifully. He was not only a wealth of information about the Park and

¹⁴ He had been interviewed only weeks before for a book on Phoenix Park.

the way it had changed but was interested in the research and what I was looking at. We arranged to meet again, to talk about the Park and anything else he had remembered but very sadly in the interim period he died. As a final demonstration of the link between person and Park there was a memorial service in the Visitor Centre, which all the management and residents attended.

5.5 Interviewing the Visitors

The final stage of data collection involved interviewing visitors to the Park. It was obvious from the time I had spent there that different times of day would bring different people, and the day of the week could alter the use of the Park completely. Accordingly, I spent time in the Park at different times through the week and during the weekend. I positioned myself at different locations on the different times, and approached walkers. Due to this research strategy I was unable to stop cyclists and horse-riders, and had to approach people as they stopped their cars, rather than those that used the Park as a thoroughfare¹⁵. However, it did prove a good way of meeting people, though those that stopped represented a certain group within the Park. Quite quickly I learnt that the power-walkers and people on their lunch-breaks or on their way to or from work were not open to interruption, and they did not stop. However, people who were visiting the Park for leisure or relaxation, taking the kids to the zoo or simple out for a walk were approachable and mostly quite happy to stop and talk. One of the main things that came out of this data stage was the perception people held that I was from the UK, and that it was interesting that I would be asking these questions¹⁶. A lot of the people who knew about the colonial past of the Park mentioned that it was not a totally negative thing, which may have been a result of our interaction, in essence my biasing the account given by the participant. However, this provided very interesting results, and the change people made in their accounts when I told them I was Irish, and from Limerick, was evident. It was this interaction and the way in which it was performed that opened up gaps and prised apart issues and let the ideas around identity emerge.

¹⁵ I was not very interested in those that used the Park as a thoroughfare for this research, as they were using it only as a road. It would be interesting to conduct work with them, to see why they did this.

¹⁶ These related to peoples uses of the Park, knowledge of the history, and how they say them come together.

This interviewing raised interesting issues surrounding working outside, relating to recording and the way the audio did not capture many of the things going on during the interview. The weather, traffic and time of day all impinged on the content and the way it was relayed, and much of this was omitted from the recording and had to be supplemented with extensive field notes.

6. Conclusion

The coming together of theory and praxis is a complicated issue, and one that I am not going to attempt to resolve here beyond the methods I employed and the reasoning behind this. The necessary reliance on theory to develop ideas, and the recourse to ideas of inductive work which underpin qualitative research seem at times to be contradictory, and in this research the premeditated choice of postcolonial theory as the focus of this work appears to move the research towards a more deductive approach, typically associated with quantitative research design. However, based loosely on the model of Grounded Theory (Glaser and Strauss, 1967) this research continually refers to theory, then data and back to theory, working in a cyclical manner to produce inductive research that incorporates deductive reasoning to regulate the theoretical perspective. The on-going processes of analysis and the awareness surrounding issues of subjectivity and meaning-making within encounters with participants meant that I was very aware of the process associated with producing this research.

In this chapter, through use of theory and demonstration of praxis, I have attempted to engage with and negotiate the issues emerging for the methods out of the theory presented in the thesis as a whole. The use of the metaphor of the dance, and the employment of the concept of *In media res* has been part of a way of engaging with complex theoretical discussions and making them more accessible and applicable to methods and praxis. There is a reflection on the limits of the methods employed, and the thesis as a whole in the Afterthought.



Chapter 5: A Walk in the Park

1. Introduction

Walking is a wonderful way of gathering data, a way of uncovering the relationship between self and place, the constitutive coingredience (Casey, 2001: 684): each essential to the being of the other. Places are not only a medium but also an outcome of action, producing and being produced through human practice. Walking within a place produces meaning and constructs understanding, and the rational of walking has altered from different times, as has the aesthetic of the Park where people walk. As Casey suggests, the human body physically encounters places, through a process he calls ‘outgoing’, and simultaneously inscribes traces of location on the human self by laying down ‘incoming’ strata of meaning (Casey, 2001: 688). Reciprocally and over time, this process also influences the meaning of places by inscribing different strata over time and developing a social memory and meaning of the place. As Halbwachs (1992) argues, due to the co-ingredience of self and place, the spatiality of memory links the social and the personal. Time alongside practice sediments meaning into places, with personal memories meshing with cultural meanings on an individual and societal scale and, as a result of these relationships, individuals engender meanings and significances for particular places. Anderson (2004) follows Casey (2001) by discussing the cultural practice of ‘bimbling’ (or aimlessly walking) through a co-ingredient environment, which can be harnessed to prompt theretofore unstated or unrecalled knowledge of the life-world. Bimbling involves wandering, reinforcing the relationship with the place through which you are moving, to reminisce about the space and re-visit life-course memories associated with the place. Solnit suggests that,

‘Walking... is the intentional act closest to the unwilled rhythms of the body, to breathing and the beating of the heart... Walking, ideally, is a state in which the

mind, the body, and the world are aligned, as though they were three characters finally in conversation together, three notes making a chord'

(Solnit, 2001: 5)

The process of bimbaling allows an opportunity for a dialogue to emerge not simply between the body and mind of the individual, but also between the individual and the place. As Anderson describes,

'It was thus a form of bodily movement that, in 'outgoing' to the environment, new as well as old inscriptions of meaning could be created and, more interestingly for research, re-encountered. As key areas, landmarks and places were bimbled through, the relaxing, relatively aimless purpose of the exercise could open up the sense to allow the re-calling of incidents, feelings and experiences that were constitutive of the individual's understanding of the life world'.

(Anderson, 2004: 258)

This process invokes memories of a place, personal and cultural, and it works off the signs and symbols in the space, moving between social understandings of different events and personal webs of understanding. As a method of gathering information, it reinvents places through memory and meaning and signs and symbols, it introduces complex webs of history in personal narratives and develops new gazes through which places constitute and are constructed by ideas of self. Walking through a park means diverse things in different epochs to different people and there are a number of gazes through which the place is assimilated.

This chapter adopts this process to take the reader on a bimbale through the Park, drawing on the main monuments of stone and history that provoke cultural memories. As we bimbale through together, the history of the Park is presented in a manner that simulates the walk, and the different cultural meanings associated with walking in this place are introduced. The aim of this chapter is to provide the important dates and people in the Park, as presented through the landscape of the Park. The path that is taken traverses different epochs, each preserved and presented in the contemporary Park, preserved for different reasons and observed with different understanding. As Solnit summarises poetically,

'the rhythm of walking generates a rhythm of thinking, and the passage through a landscape echoes or stimulates the passage through a series of thoughts. This creates an odd consonance between the internal and the external passage, one

that suggests that the mind is also a landscape of sorts and that walking is one way to traverse it. A new thought often seems like a feature of the landscape that was there all along, as though thinking were travelling rather than making.’
(Solnit, 2001: 5)

This chapter works to this rhythm, offering a description and positioning of Phoenix Park within Dublin, within Ireland and within ideas of the social, the historical and the spatial. This position is established through a historical description of the Park; how it was formed, by whom, why and when, as encountered on the walk through the Park. This chapter begins to analyse and interpret how *this* history has become accepted and commonplace, why it that these memories are evoked over others and what meanings are communicated through their presence. It looks at the symbolic significance of the history that has been preserved and presented, and the way the walk juxtaposes and positions these histories side by side each other. The embodied act of walking allows us to occupy the place through a process that exceeds the textual, and this is promoted in this account.

2. Stepping into History

The Park has had various different ‘owners’ and managers from the Irish Lords of Castleknock, the Tyrrells, to the order of the Priory of St John of Jerusalem at Kilmainham, in whose hands it was at the time of its dissolution by Henry VIII. This walk around the Park takes the reader through different areas of interest, whether historical, contemporary or somewhere in-between. The focus is not confined to the temporal; there is also a spatial focus which is as intricate to understanding the Park’s culture significance, as described in the introduction. Indeed, the two come together at certain very visible points in the park to produce landscape that has been sculpted for specific purposes, historical buildings, monuments to historical figures that are found throughout the park, the way in which the plants are distributed, and the story of each tree. This Park stands at a point between past and present, with some forces pulling it towards the past while others pushing it into contemporary Ireland, both real and imagined. This chapter is informed by historical accounts of Dublin that are based on or include reference to Phoenix Park, information that subsidises the walk and allows a more detailed engagement with the space. These accounts

date from the beginning of the twentieth century, and vary from historical accounts of the city to a tourist guide of the time. This section is also informed by more contemporary accounts from the Dublin tourist board, from the Park's displayed history and from housing association work done on the Park. When brought together these accounts offer a historically and socially aware account of the progression of this park through time. Like a walk through the Park, information is gleaned from as many sources as possible to be able to inform the things that are seen and heard around the Park. This chapter must also act as a guide for the subsequent empirical chapters, a background to the data presented and a context for the analysis.

Phoenix Park is the 'largest enclosed Park in Western Europe', comprising of 1,752 acres and is located in the west of Dublin city. The Park is bigger than all London's Parks put together, something which is much publicised and used throughout the Park's literatures. On approaching the Park, it feels very big. The walls that encase it extend far beyond the eye and the scale of the gates and roads suggest that it is an important, imposing presence in the Dublin landscape. On approaching Dublin by train or from the east or south the Park is the first sign that the city is about to spread out in front of you. Histories begin when the land belonged to a religious order, the priory of St John of Jerusalem of Kilmainham, who received the land off Hugh Tyrrell, the First Baron of Kilmainham in 1177. In 1537 this land was confiscated by Henry VIII. Following this seizure by the Crown, the lands on the northern side of the Liffey appear divided; the south-western part, on which the Magazine is now situated (see map, Appendix 1), being retained in the Kilmainham demesne, and north-eastern part, on which Áras an Uachtaráin and the Zoological Gardens are now situated, being leased to a long succession of tenants. During the remainder of the sixteenth and early years of the seventeenth century the Kilmainham Priory was used by the Chief Governors of Ireland as a country residence, and was valued especially by them on account of its wide pastures, which they used to provide financial help towards housekeeping costs, as well as a space of recreation and pleasure.

In 1611 James I granted Sir Richard Sutton, one of the auditors of the Imprests in England, the land despite protests from Sir Arthur Chichester, the Irish Lord

Deputy. Sir Edward Fisher, as assignee of Sir Richard Sutton, was leased some four hundred acres of the Kilmainham demesne, bounded on the south by the River Liffey and the high road to Chapelizod, on the east and north by the lands of Newtown and Ashtown, and on the west by the lands of Chapelizod, all of which lands are now included in Phoenix Park. The protests of the Lord Deputy had included the threat that the lands would have to return to the Crown before long, and on the arrival of his successor, Sir Oliver St. John, this threat was realised. The Lord Deputy was not happy with his residence in Dublin Castle, and he quickly identified the newly built house by Fischer set just outside the city on large stretches of land as a potential relocation. His influence meant the reversal of policy, and in consideration of sum of £2,500 to Sir Edward Fisher, the lands were surrendered back to the Crown in 1617, only six years after they had been awarded. Following Sir Oliver St. John's term of office, and residency of the house in the Park, Lord Falkland, his predecessor, took up residence in the house which was named Phoenix House. The name of this house is discussed below. It was Lord Falkland who designed the deer-Park, and the first deer-keeper, William Moore, was appointed. On the arrival of the Duke of Ormond, successor to Lord Falkland, the Park began to resemble the contemporary Park. The wall was commissioned, and the Park was enclosed and spatially defined as a fixed entity.

The boundary of the Park has not altered considerably since 1680 when the Royal Hospital was built, decreasing the Park to today's size. It is described in the official Office of Public Works leaflet from Ashtown Castle as a 'fine example of a 17th century deer-Park', and the herd of fallow deer that currently occupy the Park have lineage that can be traced back to that time. The original deer were imported from England, and on arrival they kept straying beyond the Park's boundaries, which led to the wall being built and the Park formed. The Park was not open to the public until 1745 when Lord Chesterfield, the Viceroy of Ireland at the time, opened the gates and allowed the public to use the Park for recreation. The health benefits of allowing the public into the green acreage and to breathe the fresh air (compared to the slums of the city at least) were invoked to allow this. In 1860, the management and running of the Park was handed over to the Commissioner of Public Works, which became the Office of Public

Works. This brief overview of the history raises questions and this will now be engaged with though the chapter. The different people who have walked through this Park in different times have encountered many different functions and aesthetics of the Park, and as such the way it is understood has altered with it. The rich men who developed the deer park and built Phoenix house had a very different understanding and relationship with the Park than the people allowed in after the Park was opened in 1745, who would have found the space very different.

3. Naming and Opening the Park

Fisher built a house on his newly acquired grounds located where the Magazine fort stands today (see Appendix 1). The prospect which that site commands is unrivalled in the Park, which explains the subsequent choice of it for the Magazine, and some commentators from the turn of the nineteenth century cite this as the source of the name Phoenix (notably Ball, 1902: 180), referring to the phoenix rising above the Park. Though acknowledging the similarity between the name Phoenix and the Irish *fionn-uisge* which means clear water, this account views the origin of the name as deriving from the Irish *fionn uisce* as ‘improbable’ (Ball, 1902) instead favouring the idea of the house on the hill as representing the ascending phoenix. Cosgrave (1909) calls this house the Manor House of the Phoenix, which stood on the top of Thomas’s Hill. This house became the summer residence of the Viceroys in the reign of James I, and continued to be used as such until it was superseded towards the end of the 1800s by a house in Chapelizod. Cosgrave (1909) also notes that in 1671 ‘the Phoenix and Newtown lands’, formerly in the possession of Christopher Fagan of Feltrim and Alderman Daniel Hutchinson, were purchased on the royal mandate for £3000 by the Duke of Ormonde in trust for Charles II. The new park is referred to as ‘the Phoenix Park’ in the record of 1675, and again in 1741. In 1711, during Queen Anne’s reign, it is described as the ‘Queen’s garden at the Phoenix’. This genealogy of the name demonstrates and how it was brought into common use as Phoenix Park. However the origin is still contested and further examination of where the name comes from is needed.

The Phoenix House explanation has been given a recognised position of acceptance, and that is the etymology expounded most regularly. The symbolism of the name Phoenix cannot be overlooked as the tale of the mythical bird is indeed salient in these circumstances. This bird that rises from the ashes can be found in the mythology of many different countries – China, Japan, Russia, Egypt and America. In all these versions the bird is linked with the sun and ideas of immortality. In both Japanese and Chinese versions, the bird is a union of ying and yang (China) or Ho-oo (Japan), an embodiment of gentleness and power. In China, if a Phoenix was used to decorate a house, it symbolised that loyalty and honesty were in the people who lived there. This symbolism found in Phoenix Park raises issues around whether the new inhabitants of the Park embodied such qualities, and if so to whom they were loyal and honest. In Japan, the bird symbolises the beginning of a new era, marked from when the bird comes to earth to do good deeds for people. The bird then ascends to heaven to wait for a new era. There is a certain symmetry in the symbolic stakes between these accounts. The idea that there is an external being who can come into a place and alter the entire culture, indeed herald a new epoch by its presence, can be found throughout the justification of colonialism and through subsequent theorising on this idea. And with both the idea of the coloniser and with the Phoenix, it is seen as a positive thing – the culture is in need of external aid and improvement. This idea can be found through the idea of cultivation with the land as well, a space made more beautiful through the refinement ideals of a foreign land, an idea pursued below.

It is the Classical Arabian version of the Phoenix tale of which we are probably most familiar. This bird is seen to represent rebirth, and has great powers linked to this end. According to this account, there can be only one Phoenix at a time, with a very long life span of five hundred years, 540 years, 1000 years, 1461 years or even 12,994 years according to various accounts. As the end of its life approached, the phoenix would build a pyre nest of aromatic branches and spices such as myrrh, and it would set it on fire. The bird would then be consumed by the flames. After three days the Phoenix rises again out of the ashes, born or reborn. The young phoenix then gathers the ashes up into an egg of myrrh and takes it to Heliopolis the city of the sun, to deposit it on the altar of the sun God.

The idea of (re)birth associated with the bird holds another level of meaning when associated with the Park.

The land was altered in meaning following its acquisition for the Crown. There was a period of altered state, when the Park was in transition from being a piece of land incorporated into the outskirts of Dublin, to a Royal Deer Park. This symbolically could be aligned with the time the bird is in flames, and perhaps the three days when it no longer exists. Following this there is a dramatic (re)birth. The bird has returned, altered though the same. The experiences it has gone through may have been horrific, though in fact this is absent from any account, but the spectacular reappearance of the Phoenix negates the previous three days of death. The name Phoenix emerges long before hand, but it would be of equal symbolic worth to align this emergence out of the flames with the time when the Park was opened to the public, or perhaps when it became the symbolic heart of the nascent Irish nation through the inclusion of important buildings and the home of the President (discussed below).

The term Phoenix has figured in Irish Nationalist history as well. A club called the *Phoenix National and Literary Society*, formed around 1855 in Skibbereen, was the forerunner of the Fenian Irish Republican Brotherhood which conducted armed revolts through the 1860s, 1870s and 1880s against the British presence in Ireland. It was a breakaway splinter group of the IRB, called the Irish Nationalist Invincibles that committed the Phoenix Park Murders in 1882 (discussed in Chapter 7). The Phoenix Society was betrayed by an informer and crushed by the government.

The idea of the Phoenix works in different interesting ways with the history of the Park. Indeed, on the 29th of March 1747, during the Earl of Chesterfield's Viceroyalty, the Phoenix Column on the Main Road between the then Viceregal and Chief Secretary's Lodges was erected. Lord Chesterfield who reputedly 'loved the classics, utilised the legend of the wonderful bird' (Cosgrave, 1909) depicted a phoenix rising from the flames as the top of this Corinthian column. The column is thirty feet high and bears inscriptions stating that Lord Chesterfield erected the column and beautified the Park for the delight of the

citizens of Dublin. Through this act, the name Phoenix was aligned unquestioningly with the bird, though apparently ‘many uneducated citizens of Dublin call the Phoenix the “Eagle Monument”’ (Cosgrave, 1909).

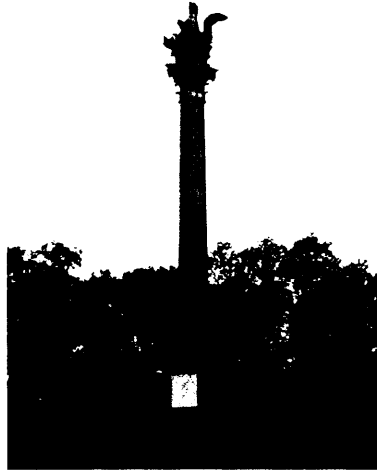

Picture 5.1 The Phoenix Monument



Picture 5.2 The position of the roundabout on Chesterfield Avenue

As can be seen from the above photos, this misconception is understandable; it is not clear what kind of bird it is, or indeed that it is indeed a bird. Unless your walk takes you directly under the monument it is difficult to see clearly what is there. The inscription is unreadable unless you cross the road onto the middle island of the roundabout where it stands, and even then it is difficult to make out and is in Latin. The inscription reads, in Latin, ‘To delight the citizens, Philip Stanhope, Earl of Chesterfield, viceroy, ordered this rough and uncultivated plain to be neatly set out’. The controlling of nature, the taming of uncivilised and ‘wild’ land is inherent in colonial discourse, and for it to be described in this inscription is enlightening. Lord Chesterfield was a benevolent Viceroy, as

discussed below, but he was also a product of this colonial discourse, he was in Ireland to tame and cultivate, and it was not solely confined to the land. The act of opening the Park to the Irish people was fuelled by a desire to help, to introduce the masses to an open space where they would benefit from the fresh air and clean spaces. Benevolent and well-wishing, Chesterfield was a colonial gentleman acting in a way he felt was best for the 'natives'. The Park, when opened, was not solely for Dublin's working class population; it was transformed into a fashionable promenade during this epoch, and gentlemen and ladies would stroll up the main thoroughfare as a way of demonstrating their connections with the viceroy and associated court during the Dublin season. This meaning has remained, with Áras an Uachtarain and Farmleigh acting as important state meeting places, and as such the main avenue is regularly the site of important processions, albeit now by car, when state heads and government leaders come to stay. When walking up the main avenue now there are various demonstrations of identity occurring; sporting prowess, new babies are paraded with pride and couples hold hands to demonstrate their love. And it can be extended, young people gather in hordes and loudly demand you appreciate their identity work, people eating lunch at the up-market café in the visitor centre work to produce a business image, and doting grandparent demonstrate their love of their grandchildren. Walking in the Park still involves demonstrating identity, just in different ways and for different reasons that in the Chesterfield epoch.

The various stories of the phoenix as relating to the Park can be seen to express what Lord Chesterfield did for the Park, and he was widely hailed as one of the 'only prominent Englishmen who showed some sympathy or kindness to the oppressed Catholic majority of the Irish people' (Cosgrave, 1909). His political position was prescribed before he arrived, though he did not follow the policy that had been given to him and provided thoughtful reflection on the situation that favoured the Irish. Cosgrave describes the turn around in his actions, as he had been sent to,

'conciliate the Catholics lest they might join in the highland Jacobite insurrection of Prince Charles Edward in 1745 [but it was] obvious from his expressions that the policy of allowing the Catholics to exercise their religion openly, in spite of the Penal Laws, was in accordance with his personal opinion.

Chesterfield said that Ireland was ground down by “deputies of deputies of deputies”

(Cosgrave, 1909)

Chesterfield did many things for the park, planting magnificent elms and other woods around the Park and perhaps most significantly opening the Park to the Irish public. His desire to allow the Irish people the chance to enjoy the land that was the Park was the first breaching of the clear demarcation between coloniser and colonised that existed spatially in Dublin at the time. The opening of the gates can be understood as a symbolic opening of the processes of reconciliation and understanding between the two groups. His compassion for the Catholic locals of Dublin and Ireland was translated into action, and his behaviour was informed through acting in the best way for the people as he understood it. While acting within the colonial discourse, and clearly embodying many of its important tenets; the benevolent gentleman, taming the uncultured, his actions did benefit the lives of many ‘ordinary’ Dubliners, and the legacy has clear ramifications for the survival of the Park.

However, the history of the name Phoenix was reconfigured by Chesterfield’s naming of the Phoenix Column. As early as 1909 Cosgrave outlines the ‘misconception’ that informs the name of the Park as detailed above, and corrects it by outlining the ‘real’ origin of the name. It does in fact come from a far older Irish ‘source’. In Wright’s (1821) *An Historical Guide to Ancient and Modern Dublin* it states that ‘near the Dublin entrance to the Viceregal Lodge, in the bottom of a wooded glen, is a Chalybeate Spa, with pleasing ground, and seats for invalids laid out at the expense of the Dowager – Duchess of Richmond for the public benefit’. This chalybeate spa was once quite famous. This is reinforced by Cosgrave (1909), Fitzpatrick (1907) and Mercredy (1905) all of whom attribute the name to the Irish *Fionn Uisge* meaning clear water, which refers to the spa found on the lands. However from 1907 the spa is reported to have ‘completely disappeared’ (Fitzpatrick, 1907) along with the other spas that were reported to have existed within the boundaries of the park, but which were not as cultivated. Another reason for the disappearance of this spa from accounts may have been the confusion which surrounds its location. Within the historical accounts there are reports which position it near the Phoenix Column, contiguous

to the Zoological Gardens, or in the ‘shady glen’ a stretch of land that is between the Viceregal and the Zoological Garden ponds. One account which dates from the time when the spa ‘still enjoyed some vogue’ (Cosgrave, 1909) describes the surrounding of the spa,

‘Adjacent to the spa is a building, formerly used as an engine-house for supplying the Military Infirmary with water, that necessity having however ceased, the edifice is converted into a ranger’s lodge’

(D’Alton no date, in Cosgrave, 1909)

The historical accounts all position the spa within the boundaries of Phoenix Park, and suggest, based on accounts from the time that this is where the Park got its name. By building the Phoenix Monument, Chesterfield was altering the meaning associated with the name of the Park; from the Irish *fionn uisce* to something associated with the mythical bird. This aligns issues of translation and language to the very name of the Park. As dealt with in Chapter 3, this was the case all over Ireland during the first colonial process of mapping and naming Irish place names were anglicised, a process which altered the way people connected with the places by removing the historic connection and social understanding.

The use of the Irish language, and the move away from it, were tied into struggles between modernity and tradition, progress and preservation, coloniser and colonised. From as early as the Irish famine (1847) there was a turn away from the Irish language by the Irish people themselves. Accounts of famine times highlight the belief that the retention of the Irish language meant death and exile, poverty and economic disadvantage (Deane, 2003: 112). Indeed Daniel O’Connell, who was known as the Emancipator of Catholics, advocated a turn away from the Irish language. Through processes which aimed to turn Catholics into a political force, he ‘turned their faces towards the modern world and advocated an abandonment of the Irish language as a means towards that end’ (Deane, 2003: 112). As in Wales and Scotland, in Ireland it was widely believed that the native language was a barrier to civilisation. English was not merely the language of a country or an empire; it also was the language of progress, of modernity. This language signified a link with modernity, which is also part of the successful history of British imperial expansion. Instead of signifying the

things which the Irish language had become associated with, like famine and poverty, the English language was crowned with progress and had a train of historical victories and strength to herald its arrival. The abandonment of the Irish language, which had such a long history, elaborate literature and had been the intimate form of representation and communication for so many centuries on this small island produced problems that refused to dissolve (Deane, 2003: 113). The elegance through which the Irish had been able to communicate in the native language disappeared, and instead people changing to English communicated in a confused and confusing amalgamation of the two. The inability for the Irish to communicate with the new language may have resulted from the recognition that to completely give up the old language was also to give up much of the literature that represented their way of life, many of the traditions which constituted it, and consequently much of the security of the group that they belonged to through a shared language. Indeed, Deane (2003) goes as far as saying that this move seriously weakened the nineteenth century idea of 'national character', if it survived at all. These issues are embodied in *Translations*, a play by Brian Friel produced in 1980 which poses the questions of language loss and acquisition in the light of modernity. This issue is discussed again in Chapters 6 and 7.

Returning this argument to the Park, the hijacking of the name *Fionn-Uisge* by an anglicised form and with a non-Irish myth meant that the Irish language, and the connected pride with the Irish tradition, was engulfed in the flames of this rising English Phoenix. Instead of there being a celebration of the 'source' of health and community, the Park was moved away from the traditional and Irish and into the modern and English. And as must be reinforced here, it was not simply a case of colonial power 'coming in' and making these changes but in fact was part of a far more complex cultural shift and change which occurred through the assemblage (Deleuze and Guattari, 2004) of colonialism. The history of the name of the Park was renegotiated and rewritten, and the public memory of the Irish origin of the name was slowly dissolved. The walk around the Park finds no signs of the original spa, or indication that the name may have such an origin. Indeed, there is no celebration of the historic importance that these spas held. As such, this piece of history, integral to the very name of the Park, is invisible and unremembered; there are no monuments to it or memories of it. The name

Phoenix is ambiguous, and allows different interpretations associated with different aspects of the Park's history to be understood as relating to the name.

4. The Phoenix Park Act 1925 and the Office of Public Works (OPW)

The Park is managed and controlled under the Phoenix Park Act 1925, which states that the Park shall be maintained as a public Park for the general purposes of the recreation and enjoyment of the public (Section 3(1)). The Superintendent governs the Park, and there is also a Chief Superintendent whose responsibilities are less formalised. There are a number of Park Rangers and guides who work within the Park's structure; the Park currently employs 75 people. The Superintendent is an employee of the OPW, as are the rest of the staff within the Park. The OPW controls the Park and organises the formal structures that impinge on it. As such, it is important to provide the social and political context that the OPW has emerged from. This social and political context allows the legitimacy making claims of the OPW to be investigated; the 'routine exercise of symbolic power' is centrally underpinned by 'administration' (Loveman, 2005: 1657). The historical legacy and ideological position of the OPW is developed through this short history. The practical implications of this in the Park are developed in Chapter 6.

The Office of Public Works is one of the oldest and most influential operational arms of the government. Between the 1670s and 1820s there were three separate institutions which constructed and maintained Irish public buildings and works; the Office of the Surveyors-General, the Barracks Board, or Civil Buildings Commissioners and the Navigation Board. In 1831, these three divisions were conflated into the Office of Public Works (OPW). The Office of Public Works, or Board of Works, was established as a department of state by legislation passed in 1831 entitled An Act for the Extension and Promotion of Public Works in Ireland (1 & 2 Will. IV, c.33). Within the OPW, three commissioners were appointed under the new act. The OPW was entrusted to supervise a wide range of government civil works, such as roads, canals, early railways, piers and harbours and river and field drainage. It took over functions previously performed by the Directors General of Inland Navigation, the Fisheries Commissioners, the Postmaster General and the Civil Buildings Commissioners.

As well as having at its disposal a large expenditure of public funds to carry out these functions, the OPW also operated as a lending agency with the power to give loans for the establishment, extension or improvement of any existing or proposed public works, provided the project was considered feasible (www.nationalarchives.ie). In 1831 the Board took over the responsibilities of the Commissioners of Civil Buildings, which involved it initially in the maintenance of the Law Courts, the official residences of the Lord Lieutenant and the officers of Government in Dublin and the Phoenix Park. Over the course of the following years the OPW took charge of the buildings occupied by the Irish Constabulary at Dublin Castle, the Nisi Prius and Rolls Courts and the Law Library at the Four Courts, the Law Library, the Royal Constabulary Depot and the Royal Hibernian Military School at the Phoenix Park, the Royal Hospital at Kilmainham, St. Patrick's College Maynooth, and the Queen's Colleges at Belfast, Cork and Galway, the Royal University (later University College Dublin) at Earlsfort Terrace, The Royal College of Science (later Government Buildings) in Merrion Street, the General Post Office in Dublin, the National Museum and National Library, as well as district lunatic asylums, post offices, custom houses and inland revenue buildings, coastguard buildings, schools, constabulary barracks, glebe houses, schoolteachers' residences, training colleges, dispensaries and employment exchanges.

During the Irish Famine (1845 – 52) the OPW ran relief by means of Treasury loans, and consequently it grew rapidly in size to deal with this responsibility. By 1846 there was an average of 90,000 employees and in the worst year of the Famine, 1847 the employment numbers peaked at 100,000. The work carried out by the OPW on the arterial drainage systems in the 1850s and 1860s altered the landscape of Ireland considerably. The OPW was responsible for guiding certain projects through their initial stages before passing responsibility to specialist Departments or Semi State bodies. Many of the light railways, which flourished at the beginning of the 20th century, were provided by or under the aegis of the OPW. The OPW ran steamer and coach services on the Shannon between Killaloe and Rooskey during the tourist season in the late 19th century. The OPW prepared plans for the development of water power and electricity at Clonlara under a Shannon Water and Electric Power Bill introduced in 1899

which did not proceed due to lack of public and financial support. The first runways and airport buildings at Dublin and Shannon were also designed and constructed by the OPW and were operational by 1940. Later during World War II the OPW was given responsibility for co-coordinating turf production and distribution by local authorities and private interests.

Under the Irish Church Act of 1869 the OPW was entrusted with the care of disused churches deemed to be National Monuments, and in 1882 it was constituted the authority for the preservation of National Monuments. The most substantial public commissions undertaken by the Board in the later 19th and early 20th centuries were the National Museum and National Library Dublin, the Belfast Custom House in the 1880's, the University buildings at Earlsfort Terrace (Dublin) and the offices of the Department of Agriculture, Merrion Square, Dublin in the early 1900's. The OPW website comments on Independence and the post-Independence epoch,

‘The transition from British to Irish administration in 1922-23 was carried out smoothly by the Board and the ensuing decade was passed in the reconstruction of civil buildings in the new state. After an inward-looking period in the mid-20th century, the O.P.W. became increasingly and forward-looking in the 1960's.’

(www.opw.ie)

The role of the OPW post-independence did not alter in any practical sense, though in the immediate post-Independence era there was a focus on the historical and the ‘traditional’ ideas of Irishness as understood by Eamon de Valera, Ireland’s first Taoiseach, and the first government of the new state. The OPW felt oppressed during de Valera’s time as Taoiseach as evidenced in the quote above, and when the Lemass Government of the 1960s arrived with its more forward looking, modernist discourse the OPW responded favourably. It is unfair to align the unease in the OPW simply with the traditional discourse put forward by de Valera, and instead must be understood in the social, political and economic context of this period of upheaval and change in the country.

The OPW had responsibility for conserving and promoting Ireland's natural and man-made heritage through National Parks and Monuments, Waterway and

Wildlife Services. However in March 1996 these functions were transferred to the Department of Arts, Culture and the Gaeltacht by Government Order. It changed back to OPW hands on the 1st January 2004 as departments responsibility changed. The work in the park is structured by a management plan. The current plan (2001) is undergoing revision (2005/ 06), since the handover from Duchas to the OPW. This plan provides a general description of the park, including its historical background. Phoenix Park has been managed as a National Park since its designated as such in 1986, which was almost a year after the Council of Europe Convention for the protection of the Architectural Heritage was adopted by the European Council of Ministers, with Ireland being one of the signatories. Under Article One of this Convention the term architectural heritage refers to monuments, groups of buildings and sites, the latter being defined as,

‘the combined works of man and nature, being areas which are partially built upon and sufficiently distinctive and homogenous to be topographically definable and are of conspicuous historical, archaeological, artistic, scientific, scientific, social or technical interest.’

(Management Plan, 2004 unpublished)

Following this definition of the park, the management objectives are ranked in order of importance. These objectives were conceived by John McCullen, the Parks Chief Superintendent. The primary objective is to ‘Conserve the historic landscape character’, which involves conserving the historic landscape of the Park and preserving all the elements of its built environment. This section recognises the Park’s ‘important political and social history’ alongside the fact that it is an important example of a late 17th century royal deer park, and contains important architecture from leading historical figures (Decimus Burton, Francis Johnson, Jacob Owen and Sir Robert Smirke).

The second objective of the plan is to encourage ‘recreational use and public appreciation’, which maximises visitor enjoyment and protects the landscape and infrastructure of the Park. There is a differentiation made here between active and passive recreation. The third objective is ‘conserving natural and other Park values’. This recognises the need to conserve the natural plant and animal

species, along with their habitats and to conserve the peace and tranquillity experienced by visitors. The fourth objective notes the importance of ‘education and research’; this is in both a formal way, with educational institutions carrying out research on the plant and animal life of the park, and with specialist groups from outside educational institutions, who use elements of the natural and built heritage in pursuit of their interests. The final objective is continued ‘fruitful and harmonious relationships between the Department [now OPW] and the local communities which are adjacent to the park’. The plan recognises that there is a co-operative and symbiotic relationship between the residents and the park, and that this must be nurtured and cultivated to ensure it continues running smoothly.

5. *Áras an Uachtaráin* and other ‘symbols’ in the Park

Since its development in the 1600s, the Park has undergone changes in function and aesthetic, and the events which have shaped the relationship between the Irish and this space, and indeed the space and the rest of the world have had implications for the nation. Phoenix Park has gradually been transformed from an outlying country estate to an integral part of the city and city life. This has occurred on both a spatial level, with the expansion of Dublin to encompass the Park’s boundaries and on a cultural level, with the inclusion of the Park into the day-to-day lives of many of Dublin’s inhabitants.

Symbolically, the Park is the heart of the Irish nation, as the President’s residence is located in the centre. *Áras an Uachtaráin*, the house of the president, has a complex history and has changed owner and function many times, mostly mirroring the Park’s position at the time. The house was completed in 1754, built by Nathaniel Clements the Chief Ranger of the Phoenix Park and Master of the Game. At this time, the Viceroys in Ireland had the Chapelizod House in the Park, though they were there so rarely that this house fell into decay. Clements lived in the house until 1777, when he died, though his wife remained there for a further four years. When she died, their son, Robert, the first Earl of Leitrim, sold the house to the government. It was then decided that this house should become the official residence of the Viceroys in Ireland. The first Viceroy to hold residence there was Lord Carlisle, and upon his arrival he commissioned elaborate stuccowork by a Dublin Master Builder to elaborate the house

immensely. His successor, the Duke of Portland did not like the house. Indeed, this viceroy seemed determined to get rid of it, and suggested that it should be offered to Henry Grattan as a tribute to his achievement in winning legislative freedom for the Irish parliament. Grattan recognised that such a gift could be seen as compromising his independence of thought and refused, leaving Portland no choice but to remain.

The Lodge remained in this use for over a hundred years. In 1918, Lord French, the viceroy, brought a military style to the Viceregal Lodge which mirrored that which was happening all over Ireland. However, French recognised that Home Rule was inevitable, and tried to appeal to the British government. He had little influence and the British government responded to these sentiments by introducing the Royal Irish Constabulary Reserve Force. The new recruits were issued with khaki army uniforms (usually only trousers) and dark green RIC or blue British police surplus tunics, caps and belts. This mixture gave rise to their nickname, the Black and Tans (in Irish, *na Dúchrónaigh*), from the name of a famous pack of foxhounds from Limerick. The name stuck even after the men received full RIC uniforms. The Black and Tans were sent to Ireland in response to clashes between the Volunteers (who became known as the Irish Republican Army) and the Royal Irish Constabulary. The level of indiscipline found within the Black and Tans led to arson, looting and murders on their part. This led to an increase in public support for the newly formed Irish government and IRA, as it looked like this would lead to an end to the violence. Lord French recognised that the Irish were being further and further alienated by increased repression, and specifically by the activities of the Black and Tans. Eventually, the British government acknowledged this, and as a last effort to win back public opinion replaced French with Viscount FitzAlan of Derwent, a Catholic. While he quickly spoke out against the Black and Tans he had little time to do anything else before leaving Ireland after only a short time as viceroy, and ending the history of Viceroys in what was then known as the Viceregal Lodge.

The building's future was now in some doubt. The new Irish Free State was formed with Dominion status and with a Governor General representing the interest of the Crown in Ireland. When Tim Healy was appointed to this post, it

was decided that the house should be his official residence. Healy was a controversial figure in a controversial post. Politically he was linked with a free Ireland, he had been a member of the Irish Party in Westminster, but he was also linked with the downfall of one of Ireland's heroes, Charles Stuart Parnell. Healy was preceded by James McNeill, who had made his name in the Indian Civil Service; he then acted as High Commissioner in London for the Irish Free State between 1923 and 1926 when he was appointed Governor General of the Irish Free State. When Eamon de Valera's *Fianna Fáil* party was elected in the 1932 General Election McNeill would have been well aware that the tensions between him and the new government would be greater than any of those previously experienced. De Valera would have an essential difficulty in accepting the King's representative. McNeill demonstrated a keen awareness by recognising that the Viceregal Lodge was, to Republicans, an unacceptable symbol of Ascendancy days and monarchical authority. Therefore, he went to Leinster House to appoint de Valera as President of the Executive Council or *Taoiseach*, a ceremony which would have previously been carried out in the Viceregal Lodge. The tact which McNeill had demonstrated was not shared by members of the new government, and it was noted on several occasions that when McNeill arrived somewhere the members of the government left. When McNeill put the matter to de Valera, it was suggested that he should simply inform the government of his movements, to avoid 'embarrassment' in the future. McNeill was outraged at this, and continued to correspond with de Valera about this matter.

Following the Eucharistic Congress, set in Phoenix Park, McNeill decided to publish this correspondence, despite the fact he had been explicitly warned from doing so by the Irish government. In this blatant challenge of wills, de Valera felt obliged to exert executive authority and requested King George V to terminate McNeill's appointment. De Valera requested that Domhnall Ua Buachalla should succeed McNeill. Ua Buachalla was a veteran of the 1916 Rising and had agreed to do the minimum necessary; to be a signatory when a signature was required. As Viceroy, Ua Buachalla did not move into the Viceregal Lodge, instead living in a private rented house, and never appeared at any public function as instructed by de Valera. In this manner the office and all

that it stood for, like the Lodge, disappeared from view, just as de Valera wished; the office of governor general faded away. The Viceregal Lodge became an empty and hollow symbol, hidden from public view.

The future of the house built by Nathaniel Clements was under serious consideration. However, when the new Constitution (*Bunreacht na hÉireann*), written by de Valera, was framed in 1936, it contained provision for a new office to replace that of Governor General. There was to be an elected President, and in 1938 Douglas Hyde was unanimously chosen. An official residence for this office was sought, and there was major resistance to the use of the Viceregal Lodge. The power of the old associations still resonated throughout Irish society. Various houses were proposed but were found wanting. Finally, and with enormous reluctance, it was decided that the Viceregal Lodge would have to be used on a temporary basis. Its name was changed to *Áras an Uachtaráin*, and in 1939 President Hyde planted new trees in its garden, a symbolic act that initiated the new era, as it became the permanent official residence of the Irish President.

There are a number of other buildings in the Park as well, built at different times through the Park's changing history. Many were built at the same time as the Viceregal lodge; others predate it considerably (Ashtown Castle for example). These buildings have altered in use as the Park has altered. The American embassy has been located in the Park since 1927, as the US was the first country to officially recognise the nascent Irish nation. The Garda Headquarters are located in the Park, as is the Ordnance Survey Office. When the Pope visited Ireland in 1979, an event of great significance at the time, he addressed the 1.4 million people from a hill in Phoenix Park. A large white cross stands in the spot where this occurred and marks the event in the Park and in the memories of the people who see it. Perhaps conscious of this symbolism, during anti-globalisation protests and more recent anti-war protests the people have tried to gather in the Park grounds, prevented by the Gardaí from doing so, and providing the scene for clashes between protestors and police. The Park is the home of Bohemian football club, and the site of horse riding and polo, cricket and hurling.

6. Monuments in the Park

On the walk around the Park it is impossible not to see certain monuments, the Wellington monument that dominates the skyline and the Phoenix monument that stands in the centre of the main road in particular, while others are hidden in quiet corners and behind tall hedges. The Wellington monument dominates the Dublin skyline from many perspectives, and so the monuments of Phoenix Park impinge on the city as a whole. The monumental landscape of contemporary Phoenix Park represents the contested heritage of the site, and of Ireland as a whole. When the Free State came into existence (post-1922) Dublin's monuments embodied this contested heritage of previous generations (Whelan, 2001: 136). The power of Dublin Corporation, then a strongly nationalist body, in the late nineteenth century ensured that nationalist heroes could be found along the streets and in the parks of the capital. This often stood in juxtaposition to the monuments already present, as in O'Connell St, the main street of Dublin, nationalist heroes stood in the shadow of the 'early erected emblem of empire' of Lord Nelson (Whelan, 2001: 136).

The representation of these nationalist figures marked a change in the landscape of the city, a 'visible landscape of memory as testament to the new political struggle' (Whelan, 2001). Of the most prominent were Michael Collins, Arthur Griffiths and later Kevin O'Higgins who were commemorated in a cenotaph at the rear of Leinster House, a sculpture of the Countess Markievicz in St Stephen's Green, and one of Sean Heuston in Phoenix Park. Additionally, the General Post Office on O'Connell St houses a bronze statue of Cuchulainn commemorating those killed in the 1916 Rebellion. Alongside this nationalist wave of statues and sculptures was a move to rid the city of the memories of the British presence. These were removed either through central government or through the illegal actions of dissident organisations. Either way, the result was the elimination of these icons. The statues of Kings William III, George I and George II were removed from city centre locations, along with monuments dedicated to Lord Gough and the Earl of Carlisle which were both in Phoenix Park. However, the large column dedicated to the Duke of Wellington (the Wellington monument) in Phoenix Park remains to this day. In 1947, the statue of Queen Victoria was removed from the grounds of Leinster House in a

symbolic gesture that coincided with Ireland's departure from the Commonwealth. It was transferred to the Royal Hospital at Kilmainham for safekeeping. In the late 1980s, the statue was transported to Sydney, Australia where it stands outside the Queen Victoria Buildings in the city centre.

The monuments in the Park that immediately grab the eye are commemorative of a time past; the Wellington monument and the Phoenix monument. It is remarked factitiously, perhaps, that the reason the Wellington monument remains is because it was too big to remove or blow up. The Phoenix monument marks the work of a man who did a lot of the Park and for the people, and so perhaps remains for those reasons. Another possible reason is the lack of symbolic association with the forms of these monuments; the Wellington monument, despite the plaques depicting senses of colonial encounter (discussed in Chapter 6), is ostensibly a large abstract form. It does not depict Wellington in any grandeur, or with military significance, though the panels on the side embody the military position having been made out of the metal from the cannons at Trafalgar. The statues that were removed, in the case of Lord Gough repeatedly, were men on horsebacks, dressed in military splendour. To find Sean Heuston takes more time, he is hidden in a beautiful natural shrine, surrounded by trees, hedges and greenery. While he is near the entrance, on the opposite side of the road to the Wellington monument, there is not the sense of impact associated with the larger testaments to people. Sean Heuston is in a quieter spot, he does not have the hordes of under-age drinkers that the Wellington monument attracts or the continual flow of cars that the Phoenix monument endures; instead his is a positioning that allows reflection and calmness, as the planners would have wished. The monuments and their cultural importance are discussed more in Chapter 6.

7. A Life in a Day of the Park

The walls around the Park are high, preventing any idea of what will be seen when you move beyond them. Walking through the Parkgate Street main entrance, the Wellington Monument rises to the left in a grand phallic symbol, as described in *Ulysses*. The gate is a black, iron mammoth, standing between massive stone plinths. On the right as you enter, there is a little Lodge

surrounded by window boxes and pots, in the summer bursting with colour and reminiscent of something that would be on the front of a tin of biscuits. There is a Phoenix Park rules poster displayed in an ornate glass and iron frame beside the house, and a turning into a pathway that winds through flowerbeds and has benches along the side. There are tall trees and hedges between this section and the main road, creating a sense of calm in the section with the flowerbeds.

On the other side of the road, people sit across the grass and base of the monument and music comes from somewhere, drifting across the air. Looking beyond the large monument land stretches on, with trees dotted across the fields. Two pathways, one for bicycles, and the other for people walking flank the road, and there is a lane along both sides of the road where cars and buses can pull in. There are metal benches along the walkway, old Victorian style benches, made from cast iron. Trees line the pathways as well, with small plaques detailing what you see. People jog and cycle past, and there is a continuous chain of cars and buses, transporting people to sites within the Park, as well as providing a scenic commute for people returning from or travelling to work. There are people driving slowly, admiring the scenery as well, some with Irish registered cars, and some foreign cars. Coach parties of tourists move through the Park, as does the signature red 'Dublin Tourist Bus', there are no public buses through the Park; a measure to try and keep the disreputable out of it and retain the low crime levels. The outer sphere of the Park has fewer trees and more open ground, though if you take one of the (concreted) paths off the main thoroughfare, you find hidden gardens of flowers and ponds. Roads splinter from the main avenue off to either side, to the left taking you to the Magazine Fort and the highest point of relief in the Park, which offers magnificent views over the city; to the right down to the People's Flower gardens.

Turning right brings you through a well-kept area of flowerbeds and benches, though at the end there is a concrete shelter covered in graffiti where groups of people congregate and drink. The mood ranges from sombre and dark to loud and abusive as you walk by, and though it is only minutes from the main road and a big side road it feels secluded walking by.



Picture 5.3 The seating area

Opposite this, surrounded by flowerbeds, is the plinth that the Earl of Carlisle statue used to stand on. The inscription has been scratched out, so it is impossible to identify from this, and there is a flowerbed around it which means it is hard to get close. Around the corner from this, moving towards the main road is the Sean Heuston statue. These monuments and their cultural significance are discussed more in Chapter 6.

Black and white cast iron signposts, in English and Irish, direct you to buildings; these signposts are both old and new, the new being made to blend with the old in an attempt to preserve. Behind the lodge at the main gate, trees hide the Irish Army headquarters. The road behind this is called Infirmary Road. On the left, small tarmac paths lead down into the People's Flower Garden. The trees of Bishop's Woods surround a small lake behind this flower garden. Continuing along the main road for about a quarter of a kilometre, the road meets Gough Junction. Here, the cross road leads northwards to the Garda headquarters and onwards in a circle around the Park, and southerly past the Wellington monument, and onto Military Road (also known as Corkscrew Road because of its layout) where it circles the Park, meeting with the northern route at Mountjoy Cross.

The road network brings you either through the Park in a straight, direct route, or there is a circle route which goes around the edge. The buildings of the Park are set out along the circle route, through each can be reached by the main thoroughfare. The buildings found in this Park are symbols and institutions of social control. Each one of them is there to govern the movement, activity or bodies of the people who come into contact with them, but how is the power

inscribed, distributed and exercised over the Park? The Army HQ and Garda HQ are interested in the control of people who problematise the system through actions which do not conform to the law. The U.S. Ambassadors residence, Deerfield, physically and visibly demonstrates the United States proximity to, and occupation within, the Irish State. Áras an Uachtaráin is the home of the President, whose power is both symbolic and political. St. Mary's Hospital is in the grounds of the Park. The Phoenix Park School is another example of a site where the governmentality and the act of socialising into a specific discourse occurs. Clustered in one spatial location are number of important government buildings; the Army, the Gardaí, and the President, which is significant in the construction of Phoenix Park as a part of the Irish State. The Park is an odd kind of assemblage, a scaled down 'model of governmentality'; it embodies all the old 'monuments' of power, which, as Foucault has argued, have a particular history in the Western tradition. The presence of these institutions are relics of older technologies of power – the school, the barracks, the hospital, the Ambassadors house, the Presidential home – Phoenix Park is a menagerie of different technologies of social control, those which find their origins within a particular narrative about Western liberal society. The Park as a space reads like a narrative of power, history and identity.

But why have these buildings been located in this space? What does this say about the Irish state and national identity? In the case of Áras an Uachtaráin, there was much resistance to the new Irish head of state, the President, being located there. When Douglas Hyde, the first President of Ireland, moved into Áras in 1938 the move was meant to be temporary, until the building could be demolished and another built. However, the outbreak of World War II meant that these plans for demolition were put on hold. By 1945, Áras had become symbolically identifiable with the President, and so the demolition never went ahead. While serendipity preserved the house, there was another motive to moving to the space. By usurping the meaning that was associated with the House during the colonial era, the new meaning could be associated with the nascent Irish state. The Park overall projects a certain narrative about the state, it is a state associated with the traditional models of power; the Park is the assemblage of state control through measures which act on and through the body.

The buildings in the Park are assembled to put forward a united sense of state presence and national identity; but gathering them into one area there is a demonstration of unity between the composite institutions and a symbolic demonstration of what are the institutions of statehood. It is interesting that the site of government, the Oireachtas, is located outside the Park (in Leinster House on Dawson Street). The way people understand this space in relation to national identity, history and power is discussed in Chapters 6, 7 and 8, where the importance of the site as a cluster of national symbols is developed in relation to key events in the Park and the themes of Irishness and authenticity.

Behind the American Ambassador's Residence the Forty Acres is located, a wide expanse of open land. The deer are often to be seen in this area, with people taking photos and seeing how close they can walk to them. Moving beyond, to the South Western edge of the Park, is the Furry Glen, a wilder area of the Park with paths through forest containing small streams. The Furry Glen is traditionally the place for 'courting couples' to go, and there are many tales of romance kindled in its environs. As the road twists around the Park there are many Lodges, where the Rangers and retired Rangers live. These small homes are found along all the main roads, sprinkled amongst the trees. These are discussed more in Chapter 9, when the accounts of residents of the Park are discussed. After the turn off for Áras off the main Chesterfield Avenue there is a signpost to Ashtown Castle, which is also the location of the Visitor Centre and Restaurant. A lodge marks the entrance, with gates that remain always open. These will be discussed in Chapter 8.

Farmleigh House is situated on extensive private gardens of 31 hectares (78 acres) to the northwest of the Phoenix Park. It was purchased from the Guinness family in 1999 for €29.2m and, following extensive renovation by the Office of Public Works, is now the official Irish State Guest House. When not being used for official government use, it is open for public tours as well as being the venue for the RTÉ proms, a public concert series that takes place each summer in a large marquee erected on the grounds of the house. The welcoming ceremony for the 15 new member states of the European Union was held here on the 1 May 2004. Many distinguished visitors have been hosted at Farmleigh including the

Chinese Prime Minister, Prime Minister of Ethiopia, King of Malaysia, British Prime Minister Tony Blair, and the Governor-General of New Zealand. In 2006 it was announced by the OPW that the Steward's House which is located in the grounds of Farmleigh has been renovated. It is believed that the house will become the official residence of the Taoiseach after the next general election in 2007 and any official engagements will be carried out in Farmleigh or Government buildings (Reid and Brennock, 2006). Farmleigh, and the potential Taoiseach residence, increase the amount of important, State buildings within the Park (or adjoining it).

8. Conclusion

This chapter has introduced and positioned the main historic dates, events and characters that have been influential in the Parks history and development into what it is today, by taking the reader on a walk around the Park. It presents some of the contentious areas of meaning in the Park and begins to display the complexity associated with the significance of different historical events and people. Within the thesis this chapter provides the essential history of the Park to position and understand the forthcoming substantive chapters. It has also provided a description of the main things that constitute what Phoenix Park is; the monuments, the houses and the history. This has been located within the contemporary management structure, which itself is positioned historically. Suggestions around theory have been made throughout, discussing the relationship between different aspects of the history of the Park and the contemporary layout, and aspects of postcolonial theory. The discussion of the name of the Park draws on ideas of language and meaning and the distortion to both associated with the colonial project.

Control is a continued theme through this thesis; colonialism is based on ideas of controlling another culture, another people, and another land. Ideas of progress are associated with this idea of control, as there is an intrinsic superiority claim in colonial discourse about culture, knowledge and ways of knowing. The extent to which these are adopted by the colonised culture is one of the main questions asked through postcolonialism and is something that is examined in this thesis. Certainly, the buildings which symbolised colonial power for so long in the Park

have now been transformed into sites of power in Ireland, but it is old technologies of power which may have persevered. The Park can be understood as an assemblage of different technologies of social control, a scaled down 'model of governmentality', that work on and through the state in multiple ways. The relationship between culture, politics and state is developed in the next chapter, through ideas of authenticity.



Chapter Six: Authenticity, Modernity and Postcolonialism

1. Introduction

The complex interaction between politics, state and culture has ramifications for the way the Park is constructed and understood in public and political discourses. This chapter positions it within these forces, looking at the ideas that have informed notions of modern Ireland and the place the Park holds in these conceptions. In addition to this, it looks at the key institutions that have held power over the Park. As a key theme which has emerged from the empirical work, the idea of authenticity is developed with regard to an idea of an 'authentic' Ireland, ideas of an authentic history and layout of the Park and the overlap between the two. The way in which management make recourse to this idea is looked at and the way they understand it and the processes surrounding it.

Visitors are often surprised by Ireland's modernity. There is a sense of forward looking-ness and materialism that seeps out of Dublin in particular and increasingly Cork, Galway, Limerick and more rural settlements. Since the end of the twentieth century, Irish per capita income now surpasses Britain, and this manifests itself through the country; gone is the laid-back stereotype of the dishevelled man resting on his shovel as the world passes by; instead people are waking early, joining the grid-locked traffic and skipping lunch in attempts to increase productivity and profits. The truth is that the old Ireland always existed more in Hollywood than in Ireland. The current surge of modernity has been in the making for over 150 years; and recent scholarly studies emphasize this. They show that, far from being obsessed with the past, what the Irish really worship is their own power over it, including (if need be) their power to liquidate seemingly sacred traditions. The self awareness with which the 'traditional' is marketed to visiting tourists marks this modernity, mocking the traditions with the same breath as they are being endorsed. However, following the speed of the disposal of the Irish language in the quarter-century following the famine, the Irish came

to approach their cultural past uncertainly, almost apologetically (Kiberd, 1998). The uneasy relationship between past and present and, indeed, future is discussed in this chapter in relation to ideas of authenticity and the complex political and cultural relations.

2. Postcolonialism and State Affects

One of the effects of British policy was to turn Ireland into a crucible of modernity. Radical thinkers in Britain as well as Continental Europe had always been responsive to the idea that the modernizing experiment in Ireland could be turned to the advantage of the colonised. Marx, for instance, had repeatedly spoken of Ireland as the key to revolution in Britain; only if colonial rule in Ireland were broken could socialists expect the wider collapse of imperialism and with it of chauvinist ideas in Britain itself (Marx, 1972). By seeking national rights, the Irish would be thoroughly international in effect. For a real revolution to occur, said Marx, the aristocracy had to be overthrown and that was more likely to be achieved in Ireland, 'the Achilles heel of the empire'. James Connolly, the socialist leader of the Citizen Army in the 1916 Rising, put the same idea more colourfully when he wrote that 'a pin in the hand of a child can pierce the heart of a giant' (quoted in Kiberd, 1998).

Ireland was the first English colony to decolonise. Compared with many other former colonies, it avoided some of the major pitfalls of independence; within a decade it had achieved the orderly democratic transfer of power between rival parties recently split by civil war; it assumed an authoritative voice at the League of Nations and, later, the UN; and Irish society was bound together by a high degree of social consensus. Unlike post-imperial Britain, it accepted a fully democratic form of the State with a written constitution which recognized modern ideas of citizenship and rights. The early years of the infant state were characterized by an obsession with public office; the holding of a state post became the goal of many lives, what the Irish now had in place of the old aristocracy of inherited wealth and land. This served to create a 'state class', which lived only to hold office. Like the old gentry, the new class often regarded merchants or business people as crass, even uncivil, and it favoured classical learning as an apprenticeship for public service rather than science or technical

subjects. A job in the civil service was as prized in independent Ireland as it would later be in postcolonial India or Africa.

However, in the past fifteen years Ireland has become a global economic success story. The transformation of the economy over this period has been dramatic; between the mid-to-late 1980s and the present, Ireland's national income per head rose from 65% of the Western European EU average to above parity; unemployment fell from 17% of the labour force to around 4% today; government debt fell from 120% of GDP to around 30%, and an increase of more than 70% in the numbers at work saw emigration give way to very substantial immigration (Barry, 2006). But why did it take so long? Wherever the emigrants of earlier days went, they won praise for their industry and application. Many made fortunes in consequence, and were left wondering why at least some of those at home could not seem to do the same. But the State which emerged in 1922 was a powerful apparatus for the discouragement of enterprise. Those who assumed control of it were exhausted after years of war and had little energy left with which to reimagine the national condition, to shape new administrative forms, inducing in the new government an excessive caution. 'We were the most conservative revolutionaries in history', said the young minister for justice, Kevin O'Higgins (quoted in Kiberd, 1998). The state apparatus remained unmodified since British days, and it condemned many people (as it was designed to do) to live as second-class citizens.

In the largely rural society, the political elite inserted its members as 'fixers' between the poor and the forces of social authority. Since most of the poor had little reason to accept, much less love, the new State, convincing had to be done to win for it a certain assent – and thus emerged de Valera's Fianna Fáil party out of the ashes of a lost Civil War. Founded in 1927, it soon enough recognized the State and was elected to single-party government in 1933, acting thereafter as a buffer between individual and State, rather in the manner of the Congress party of India. In doing this, Fianna Fáil won over to the State a whole range of people whose loyalty might otherwise have been withheld – Irish speakers, landless labourers, Protestants, small farmers, women. As happened also in India, this middle group of fixers fed off various forms of insecurity – the insecurity of a

fragile new state about the loyalty of its people and the insecurity of many people about the viability of the state.

Ireland remained protectionist after most of the rest of Western Europe had moved toward freer trade. The post-war boom of the 1950s saw Western Europe achieving growth rates of almost 6% per annum while protectionist Ireland stagnated with a growth rate of less than 2%, an employment growth rate of less than 1%, and recurrent balance of payment crises precipitated by the need to import all the things the country was unable to produce for itself. Over the course of the 1950s, over 400,000 Irish people emigrated out of a total population of less than 3 million (Barry, 2006). One of the main reasons for these problems was the reluctance of Fianna Fáil to alter their ideological commitment to agriculture as the main engine of growth for Ireland. The first drive to attract foreign capital was initiated by the non-Fianna Fáil coalition governments of the periods 1948-51 and 1954-57, which also established the Industrial Development Authority within the Department of Industry and Commerce in 1949 to initiate proposals for the creation of industries and to attract foreign industrialists. Various other schemes were introduced through the IDA that developed the entry of foreign corporations and began to reorientate Irish industry towards export markets, and this soon began to improve the economic situation of the country. This shift has been attributed, partly at least, to the report Economic Development prepared in 1958 by T.K. Whitaker, the chief civil servant in the Department of Finance (Barry, 2006).

The 1980s also marked turbulent economic times for Ireland, as with most of the world, with the two oil crisis prompting increases in spending and then scrambling to increase tax to cover it. However, during this time there were changes at a societal level that would set up the Celtic Tiger, such as, the increase in tertiary education provision, with the development of Regional Technical Colleges. The massive influx of foreign investment into Ireland from the 1970s onwards marked an important departure point for the Irish economy, and continues to fuel the economic fires in contemporary Ireland.

This account of Irish economics following independence acts as a background to the following section on Park Management; the different decisions made about the Park, and by the OPW and the management must be contextualised in the historical ideologies and actions of the political parties. The conservative, protectionist era can still be seen in some residual policies relating to the Park; these links are developed in the follow section.

3. Park Management

Responsibility for Phoenix Park has been predominantly in the hands of the Office of Public Works (OPW) since 1860. In 1986, it was designated a National Historic Park and there were moves towards conserving its landscape as outlined in the 1986 Management Plan (OPW, 1986), as discussed in Chapter 5. The designation of ‘National Historic Park’ doesn’t hold any legal meaning, as the Chief Superintendent said ‘I actually came up with this idea of creating a national historic park which has no legal foundation, but has enough to frighten people away, and our minister ran with it.’(Chief Superintendent, 13th December 2005). This meant that there was a focus on ‘conserving the historic landscape as well as preserving buildings and other architectural features which confer an historic ambience on the park’ (McCullen, 1993: 83). The timing of this designation was important, as the Park had been ‘handed over’ to the Local Authority to run, which was seen as negative and appropriate action was taken.

‘Well a couple of things happened in 1984 the government actually handed us over to the Local Authority, the whole park, the decision was made and we kinda reversed, we fought a rear-guard action and fought that it was an unwise thing to do, because when you’ve ... we’ve always been under central government, we’ve always been under state control, that’s back to the Viceregal times, the heads of state and that sort of thing, and we knew that it was important. If you’re with the Local Authority you’re a political football that sort of thing, you’ve people looking for more playing grounds that sort of thing, they’d want more travelling. So, we’re a little bit removed from that sort of thing, we’re a stage removed from the local representatives.’

(Chief Superintendent, 13th December, 2005: lines 80-89)

This privileged position is important and the protection of the Park is safeguarded by the various checks which it has to go through for anything to happen in it. There was a shift in management control from the OPW to Duchas, the Heritage Service of the Department of Arts, Heritage, the Gaeltacht and the

Islands between 1996 and the first of January 2004. During this time, Duchas began a new Management Plan, to replace the 1986 one and the OPW took over the project. During the research period this plan was still being finalised, though a second and near final draft was available for examination. The Park is now, once again, under dual management, with the Department of the Environment taking control of the policy side, and the OPW continuing to look after the management of the Park, as discussed in Chapter 5. This has been in place for less than a year (since 2005), and so far there has been no incidences of antagonism or friction between the two bodies.

The management of the Park is divided between the Chief Superintendent and the Superintendent. The Superintendent is female for the first time in the Parks history, which is hoped to reflect the changes which are occurring. There are 75 staff members, a reduction from 130 since 1989 due to the financial necessity. Some of the rangers, some ranger's widows and the Chief Superintendent live in the Park, in stark contrast to the times when all the people who worked in the Park had to live there, in order to provide 24-hour vigilance. This is further discussed in Chapter 9, where the experiences and changing importance of living in the Park is discussed.

4. Positioning the Park in a Past, Present and Future Dublin

The opening paragraph to the Phoenix Park management plan provides a 'General description' of the Park. This positions Phoenix Park's size in relation to all the parks in London and New York's Central Park (843 acres). For purposes of comparison, these are used as the benchmarks, and Phoenix Park is bigger than both¹⁷. The use of these parks may be understood as a method of positioning Phoenix Park globally. However, the choices of cities with which the comparisons are made are of symbolic relevance as well. In the Park's literature the statement that the Park is bigger than all of London's parks put together figures with a high degree of regularity. The significance of this statement is greater than simply a way of making reference to size. Indeed, the size of all the

¹⁷ Phoenix Park is described in much of the literature about it as the largest enclosed urban park in Europe – this is incorrect, with Sutton Park in Birmingham holding that accolade at 2,400 acres.

parks in London is something which could be open to debate and analysis, there are surely areas not classified as parks or which function as something else, though are classified as parks. If we understand it as metaphoric, that the size of the Phoenix Park is being understood in terms of another concept, that of all the parks in London, we can begin to get a sense of the significance given to the parks in London, or indeed London itself. The statement acts as something representative or suggestive of something else, a symbol of something greater than simply the size of the parks. It could be read as having an inherent value within it, a statement about not only park size, but also the Park itself. Metaphors represent key rhetorical tools, establishing symbolic equivalence or correspondence between different levels of meaning (abstraction) and claim making. New York and London are the most commonly called upon symbols of modernity in cities. They represent the urban developed in a way which moves away from the traditional. These are cities that are paradigmatic of modernity as a result of their economic and cultural pre-eminence within Western society. They provide the symbolic heart of Western society today; they represent what is strived for and what is possible. In addition to London and New York, Paris is also often included in this special triad of modernity (Parsons, 2003).

So how does Dublin fit into this framework? In the 1991 preface to the new edition of *Modernism, 1890 – 1930*, Bradbury and McFarlane present a suggestive list of what they describe as the ‘hidden’ cities of modernity, which includes ‘Rome, Vienna, Prague, Budapest, Munich, Berlin, Zurich, Oslo, Barcelona, Saint Petersburg, *even Dublin* and Trieste’ (1991: 13, my emphasis), most of which are overlooked in studies of urban modernity. So Dublin is allowed into the modern cities as a ‘hidden’ city, an overlooked example of the traits which define the special three (London, New York and Paris). However, the classification must not be presumed to be a clear distinction between dynamic modernisation and stagnant tradition, between modernity and non-modernity, but instead a more complex scenario in which late forms of modernity attempt to live up to the example of the leading world economies. Marshall Berman (1982) provides an interest context in which to view alternative processes of modernisation. The examples of Paris and St. Petersburg illustrate two alternative routes, in which spectacular examples of industrial and economic

progress constitute a norm against which other nations and cities become anomalies and in standard narratives of modernity, simply invisible.

‘At one pole we can see the modernism of advanced nations, building directly on the materials of the economic and political modernization and drawing vision and energy from a modernized reality – Marx’s factories and railways, Baudelaire’s boulevards – even when it challenges that reality in radical ways. At an opposite pole we find a modernism that arises from backwardness and underdevelopment’

(Berman, 1982: 231 – 2)

This ‘modernism of underdevelopment’ as Berman calls it, is ‘forced to build on fantasies and dreams of modernity, to nourish itself on an intimacy and a struggle with mirages and ghosts’ (1982: 232). However, lacking the sufficient means and resources these visions remain hauntingly unachievable, resulting only in superficial reflections or bizarre distortions of the modernity they mimic. Dublin does not rest well in this category of ‘underdeveloped’, this was not a problem faced by the city when it was first beginning to flourish. Indeed, because of the special position it held in the colonial portfolio of England, regarded as the ‘second city of the Empire’ for some time (cf. Whelan, 2003), Dublin was lavished with buildings of great elegance and achievement. Its position as a port added to this, with Dublin being used as a portal to the UK. In addition, various things were tested in the laboratory that was Ireland in colonial times; this resulted in Ireland gaining an operational postal service before the UK, and the introduction of national, state primary schools to provide universal education (Kiberd, 1995).

5. The Architecture of the Second City of the Empire - Georgian Dublin

Anthony King (1976, 1990) has proposed a theory of colonial urban development to explain the political, economical and cultural processes that gave rise to new cities in colonised territories. Colonial cities were, according to King, important sites in the transfer of modern capitalist culture to new worlds. This can be seen in the architectural form and planning of such cities which regularly mimicked the cities of the imperial home. Colonial cities also operated as important sites in the deployment of the technologies of power through which the indigenous populations were categorised and controlled. Here, town planning became the mechanism by which colonial adjudications of cleanliness, civility and modernity

were realised quite literally on the ground. Not least, it was in the name of the ideal city that many of the most comprehensive colonial territorialisations and displacements occurred and the most rigid policies of separation were implemented (King, 1990: 9). Of course, colonialism did not simply involve the transfer of metropolitan processes of urbanisation to the colonies; there was a reverse movement as well. As King argues, ‘urbanism and urbanisation in the metropolis cannot be understood separately from development in the periphery’ (King, 1990: 7). This involves more than the process that brought eroticised fads to the architecture of imperial cities or saw monuments made to the triumphs of the empire. The primary production and resource extraction in the colonised peripheries facilitated, indeed necessitated, the growth of industrialised and commercialised urban centres in the imperial core.

The architecture of Dublin is predominantly Georgian in the city centre, and especially on the South side of the city, and the centre of this is University of Dublin, Trinity College. Georgian Dublin is a phrase used that has two interwoven meanings. The first is used to describe a historic period in the development of the city of Dublin from 1714 (the beginning of the reign of King George I of Great Britain and of Ireland) to the death in 1830 of King George IV. This period, the reign of the four Georges, is symbolised by a particular and unified style, derived from Palladian Architecture, which was used in erecting public and private buildings. The second is used to describe the modern day surviving buildings in Dublin erected in that period and which share that architectural style. Though strictly speaking, Georgian architecture could only exist during the reigns of the four Georges, it had its antecedents prior to 1714 and its style of building continued to be erected after 1830, until replaced by later styles named after the then monarch, Queen Victoria. The Provost's House at the corner of Trinity College and Grafton Street, built in 1760, is one the grandest of Dublin's Georgian mansions, with a coved ceiling in the salon which runs the entire length of the building.



Picture 6.1 Provost House, TCD

The Bank of Ireland on the corner opposite Trinity was originally designed by Edward Lovett Pearce and built between 1729 and 1739 to house the Irish Parliament. This building was the symbol of Ireland's Georgian era, and when it lost its power on the 2nd of August 1800, with the Act of Union, there was a feeling of loss. The building was acquired by the Bank of Ireland and opened as its headquarters in 1801 (www.irelandheritage.ie).

On the other side of Trinity College is Merrion Square, a splendid example of Georgian houses surrounding a beautiful park. This is one of five Georgian squares¹⁸ and terraces in Dublin which were laid out and named after wealthy landowners or English lord-lieutenants who were among the major power brokers in the eighteenth century city and a critical impetus in its development during this period. These buildings reflected the wealth and affluence which was associated with this epoch for Ireland, simultaneously encompassing the position that Ireland held in the Empire through the buildings.



Picture 6.2 Merrion Square

¹⁸ Merion Square, St. Stephens Green, Fitzwilliam Square, Parnell Square and Mountjoy Square.

In the years following independence, some commentators suggest that independent Ireland had little sympathy for Georgian Dublin, seeing it as ‘a symbol of British rule and of the unionist protestant community that was *alien* to the nascent idea of Irish identity proposed by De Valera and the nationalism associated with the new state’ (Coogan, 1996). By that stage, many of the gentry who had lived in the Georgian houses had moved elsewhere; some to the wealthy Victorian suburbs of Rathmines and Rathgar, Killiney and Ballsbridge, where Victorian residences were built on larger plots of land, which allowed for gardens. Those that had not moved in many cases had by the early twentieth century sold their mansions in Dublin. The abolition of the Dublin Castle administration and the Lord Lieutenant in 1922¹⁹ saw an end to Dublin's traditional Social Season of masked balls, drawing rooms and court functions in the Castle, and this marked an end to a particular way of Dublin life.

By the 1930s, plans were discussed in Eamon de Valera's government to demolish all of Merrion Square, the most intact of the five squares, on the basis that the houses were ‘old fashioned’ and “un-national” (Coogan, 1996). These plans were part of the *Sketch Development Plan*, designed by Abercrombie, which had as its Key Headings: communications, regional planning, new public buildings, housing and playgrounds in central areas, neighbourhood centres, health and recreation, proposed reclamations, zoning and the boundary of the city (compiled from Abercrombie, 1941). At the fore of these concerns was an emphasis on civil improvement, and the building of a new metropolitan cathedral was foremost among the proposals contained in the plan, to be designed as an edifice which would symbolise the spiritual life of the people (Abercrombie, 1941). The importance of the correct site was crucial to this symbolic statement, and Merrion Square was at first regarded as a suitable position. However, the *Development Plan* stated that this site would not provide the ‘dignity of setting,

¹⁹ The Irish Free State came into being in December 1922, replacing two co-existing but nominally rival states, the *de jure* Southern Ireland, which had been created by the Government of Ireland Act 1920 and which from January 1922 had been governed by a Provisional Government under Michael Collins and the *de facto* Irish Republic under the President of Dáil Éireann, Arthur Griffith, which had been created by Dáil Éireann in 1919. (In August 1922, both states in effect merged with the deaths of their leaders; both posts came to be held simultaneously by W.T. Cosgrave.)

nor the dominance in the city, which such a building demands' (Abercrombie, 1941).

In the journal *Studies*, three prominent individuals with an interest in planning issues were invited to comment on Abercrombie's plan, including the site of this metropolitan cathedral. Louis Giron, then president of the Royal Institute of Architects of Ireland observed with regard to the proposed cathedral that Merrion Square 'was not entirely suitable' (in Whelan, 2003: 153). His reasoning behind this rested on the lack of visibility for the cathedral at that site, and also that it would be 'a pity to build on one of the city's open spaces, if an equally suitable site could be found elsewhere' (in Whelan, 2003: 153). The architect John J. Robinson proposed a solution, arguing that the alternative site, the quayside, would cost a comparable amount. To overcome the problem of space for the cathedral, he proposed the demolition of the Georgian houses on Merrion Square. He stated that,

'The Merrion Square houses, in spite of the gentlemanly and indeed genteel facades, are really very old gentlemen whose days are numbered. They are as moribund as their Capel Street contemporaries in spite of their more orderly old school tie traditions, and I venture to suggest that their term of survival is just as limited... their day is done – the Georgian era is over, and there is little sense in seeking to perpetuate it...their conversion into flats or offices makes only a poor compromise, however skillfully it may be carried out. The social structure and conditions which have brought them into being have long ceased to exist, and I submit that nothing is left for them but demolition – with possible modern replacement or the creation of open spaces.'

(in Whelan, 2003: 154)

This position was strengthened by the nascent nationalism which underpinned the development plan, and was it not for the inappropriateness of the Merrion Square site for other reasons it may well have been the site of the national cathedral. The third commentator in *Studies*, C.P. Curran, welcomed the plan for Dublin though argued for the preservation of all existing open spaces, including Merrion Square. Merrion Square was saved, for the time being at least. Indeed, most of the *Sketch Development Plan* was not carried out. The outbreak of World War II, together with the economic environment which prevailed, prevented the proposals from reaching fruition. The declaration of the Irish Republic in April 1949 provoked a flurry of optimism, with economic growth riding the wave of the increased consumer spending at home in the aftermath of

the austerity of the war years and also the rise of exports to Britain. This initial flourish, which incorporated infrastructural building and growth, was ended by a decade marked by economic crises. Despite this, consolidation of nationhood continued spatially, with the modernistic expressions of Busárus and Liberty Hall which are temples to concrete and functionality.

Not all of Georgian Dublin escaped destruction as Merrion Square had; Mountjoy Square was ultimately reduced to a state of near collapse, with many of its houses on what had once been Dublin's finest Georgian square reduced to rubble by property developers. The world's longest row of Georgian houses, running from the corner of Merrion Square down to Lesson Street Bridge, was sliced in two by the decision of the Irish government in the early 1960s to demolish part of the row and replace them by a modern office block. These buildings were refronted in the 19th century and later used as shops. The decision in the late 1950s to demolish a row of Georgian houses in Kildare Place and replace them with a brick wall was greeted with jubilation by a republican minister at the time, Kevin Boland, who said they stood for everything he opposed (Coogan, 1996). He described members of the fledgling Irish Georgian Society, newly formed with the aim of protecting Georgian buildings, of being 'belted earls' (Coogan, 1996), echoing the argument against the old Georgian houses forwarded by the architect Robinson in discussing the metropolitan cathedral.

The Phoenix Park was unaffected by this State-led opposition to all remnants of the colonial past, and the buildings were preserved as they had been despite seismic shifts in function as discussed in Chapter 5. This juxtaposition between the inner city new development and the Parks exclusion needs to be examined. It is at once included and excluded, standing in stark opposition to the ideals being proposed by the new State as a park developed for British recreation, while at the same time being centrally positioned in the state building project through the situation of some of the most important institutions within its walls. Government buildings were located on Kildare Street, but the President lived in Phoenix Park, and there are a number of important state institutions within its walls, as

discussed in Chapter 5. The Park was positioned at the boundary of state building whilst also being central to the apparatus through which this it was occurring.

Phoenix Park was not included in the regeneration of the city, the symbolising of the new state, though it contained some of the main state forces and powers. The lack of intrusion that the 1916 Rising had on the Park, in stark contrast to the turmoil left behind in the city centre can be held accountable for some of this exclusion. There was some activity in the Park during the Rising, when thirty members of the Irish Volunteers and Fianna Éireann captured the Magazine Fort on St Thomas' Hill, within the Parks boundaries. They took guns from its stores and withdrew, after setting fires to blow up the Magazine's ordinance, however the fuses burned out before reaching the ammunition and little damage was caused.

The immediate necessity to redevelop Sackville Street (now O'Connell Street) and areas around the General Post Office where the main fighting had occurred meant that it was the pressing concern. The destruction of this period was overshadowed by the War of Independence which began in September 1919 and raged until July 1921, during which time more than 700 people were killed and 1,200 wounded (Whelan, 2003). Following the signing of the Anglo-Irish Treaty in December 1921 the republican ranks split and fighting erupted between these splinters. Buildings such as the Four Courts, the high courts of Ireland, were occupied and became the site of fights between the anti-Treaty irregulars and the pro-Treaty government forces. The fighting was resolved through force which meant the buildings which acted as barriers took a lot of the bullets and bombs. This fighting did not extend into the Phoenix Park main buildings, despite their prominence. It may have been the peripheral location; the distance from the centre of the town which meant that fighting did not spread into the Park.

Following this insurgence, the new state was faced with an even greater battle – the urban regeneration of the city under a new state, and the necessity to mark the change appropriately. The post-boxes were painted green covering, through not obliterating, the Royal insignia of *Victoria Regina* or *Edwardus Rex*. State agencies were re-christened using the Irish language, streets were renamed and

monuments were erected and destroyed. The Rising of 1916, coupled with the War of Independence and Civil War, provided a number of heroes to stand upon pedestals throughout the city and the country. In their geography and iconography these monuments carved out a visible landscape of memory as a testament to the new political situation (Whelan, 2003: 157). As part of this was the removal of statues to British rulers and monarchs. The iconography of past times was to be replaced with new icons and new symbols. However, as the examples below illustrate this process was rarely straightforward and often betrayed the ambivalence and problems associated with the construction of a new State and nation, developing on their discussion in Chapter 5.

In Phoenix Park a monument to one of the heroes of the 1916 Rising, Sean Heuston, was commemorated in 1943. Heuston, a captain in the Volunteers, following orders from James Connolly, occupied the Mendicity Institution on the South Quay for three days, surpassing the three hours he had been ordered to do. He was executed, aged nineteen in Kilmainham Jail on the 8th May 1916. The central train station is named after him (Heuston Station) as is the bridge beside it. He stands in the People's Flower Gardens, splendid in his military uniform, with a simple inscription of his name. In the interview with the Park's Chief Superintendent (13th December, 2005), Heuston's position in the Park is problematised. He was, through his short lifetime, apparently a strong advocate for the building of public housing throughout the Park.



Picture 6.3 Sean Heuston in Phoenix Park

In his interview, the Chief Superintendent lamented the removal of the monument to the Earl of Carlisle in 1958, which stood behind Heuston's statue in

the People's Flower Gardens. The seventh Earl of Carlisle, George William Fredrick Howard, opened the Flower Gardens to the people of Dublin and Ireland, and the memorial was erected by public subscriptions in 1870. The statue was removed as part of the post-1922 drive to remove legacies of colonial rule, along with the statue to Lord Gough in the Park, as discussed below. The plinth on which the monument once stood is still present, though the name and dates are scratched out. The plinth is treated as though it were a monument in the Park though; with a flowerbed around its base. It remains in an esteemed position, between the People's Flower Gardens and main entrance.

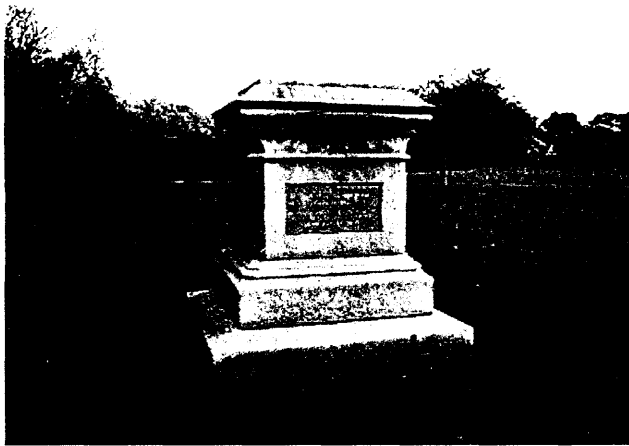

Picture 6.4 The Earl of Carlisle Plinth

This empty plinth is a highly symbolic gesture; within the single monument it embodies the ambivalence held in the Park management towards the past. While the Park management recognizes the importance of Phoenix Park as a contemporary Irish space, there is nostalgia for the past when the Park held a more significant position in society and was run in a more impressive way. For the Chief Superintendent, the work done by the Earl of Carlisle with the People's Flower Gardens and allowing the public into them usurped his national identity and made him primarily a benefactor of the Park. The following section explores this ambivalence relating it to ideas of nationality and the nation.

6. Links across the Empire

In the interview with the Chief Superintendent he uses India as an example of how the state should deal with the statues of the British following independence (13th December, 2005). He describes how in New Delhi there is a large park

where they have put all their statues, and this has now become one of the most important tourist sites in the country. This is the one time that the historical similarities and potential comparisons between Ireland and India emerge in the interviews, despite there being a number of points where it could arise. On the Wellington monument, one side is dedicated to Wellington's victories in India. The cast iron displays, made with the metal from cannons used at Waterloo, depict various scenes and messages, though the contemporary graffiti are perhaps the most striking visuals on approaching the monument. It is also a site of illegal public drinking within the Park and the monument's base is often covered in broken bottles and empty cans.



Picture 6.4 The 'Indian Wars' by Joseph Kirk, on the Wellington Monument

When discussing the replacement of the Gough Statue which used to stand at the first roundabout on Chesterfield Avenue, and which was blown up by nationalist opponents on a number of occasions, the Chief Superintendent justifies the replacement of the statue by saying that Gough was Irish, and when fighting for the British did so only in India. This undermines the idea that there can be one unified outlook or identity associated with postcolonialism that unites the countries which congregate under the tag. As the experiences differ substantially from country to country, any argument for a coherent identity which can be labeled as postcolonial falls apart. This is not to suggest that there are no similarities; there are obvious overlaps and shared experiences, but the manner in which they are interpreted, understood and presented is different from one local context to the next. The lack of recognition that there are similarities within the empirical data is interesting, and the continued presence of the Wellington

monument, with its clear colonial sentiments and celebrations (such as the Indian Wars side above), suggests that the action against the statues of Gough and Carlisle is because of their links with the British administration, and not the actions which they carried out in Ireland or elsewhere. It appears they are symbolically targeted because of their affiliation to the empire, rather than personal actions. However, the Wellington monument remains, possibly because of its size and the impressive feat necessary to remove it, or because it has been added to the symbolic iconography of Dublin; an identifiable monument that does not necessarily represent Wellington, but instead has come to be part of the topography of the city.

The Chief Superintendent argues that the presence of statues, such as the Gough Statue, ‘Adds to the historic fabric of the park and an awareness of our history. We don’t have to embrace Queen Victoria, but let’s embrace our history’ (Chief Superintendent, 13th December, 2005: lines 224 –6). He moves on to discuss a social history associated with the statue, as a meeting point in the Park, ‘We’d meet at the Gough monument, you met your family there, your friends there, you courted your wife and you brought your kids’ (lines 337 – 8). This sentiment reinforces the ideas that are found throughout the Park, and indeed are epitomised by the Park, that space, and monuments, can be reclaimed and their understandings can be rewritten and localised. The Chief Superintendent commented that if the intended statue of Wellington on horseback had been realised in front of the Monument that would have been blown up too, as the people in Dublin ‘don’t like horses’ (Chief Superintendent, 13th December, 2005: line 232). The military symbolism associated with horses and uniform may indeed have acted to provoke reaction, in contrast to the spire of the existing Wellington monument. The Gough statue depicted an Irish man who had become a General in the British Army, and would be the most contentious statue to be returned to the Park (discussed further in Chapter 9). However, the Earl of Carlisle worked to open the Park to the people, though he was a symbol of colonial power in the country as the Viceroy. Wellington was Irish, having been born in Dublin, though he turned his back on this part of his identity, claiming to be British and fighting for the British at various key battles.

The symbolism of the plinth of the Earl of Carlisle monument remaining, the survival of the Wellington monument through turbulent times and the presence of Sean Heuston mean that the Park has a varied monumental landscape. And it is this variety and juxtaposition which encapsulates the Park so clearly; the coming together of different politics, cultural ideologies and historic figures makes the Park a space where identity politics are being contested and discovered, uncovered and produced. The next section will look at how this history, presented monumentally as varied and collaboratively produced, is located in the more official discourses relating to the Park.

7. Managing the History of the Park

The history of the Park is something used constantly in the Management Plan both as a way of authorising action and as a means of suppressing change. While the Introduction of the Management Plan mentions the 1662 formation of the Park, the reference to its history after this rarely predates the 1740s. The objective of conserving the historic landscape of the Park refers to a historical landscape that can be found in the 1700s, and more precisely the formal layout of the Chesterfield era of 1746, which encompasses the Victorian landscape overlay by Decimus Burton. The important architects who are named as making up the Park's impressive array of buildings, Francis Johnson, Jacob Owen and Sir Robert Smirke also date from that era. There is no mention given to the contemporary architect Ciaran O'Connor who designed the Visitor Centre and is the OPW's senior Assistant Principle Architect and winner of various prizes for his work on heritage sites around Ireland. References to this era, the 1700s, are primarily concerned with the 'Designed Landscape', as it is called in the Management Plan, and the buildings which are in various different enclosures. There is a high degree of importance placed on Phoenix Park being Ireland's only example of a late seventeenth century deer park, or the only example of an Irish royal deer park. Coupled with this is the desire for the Burton landscape to be rediscovered and preserved, a landscape which is the primary landscape layout today. There is no reference to any alternative landscape layout which the

Park may have formally had²⁰. Indeed, the Management Plan does recognise that the changing landscape of the Park can be traced cartographically, though it refers to a starting point of 1756 using Rocques maps, through to the contemporary Ordnance Survey map (Appendix 1).

The People's Flower Gardens were laid out in 1864, reputedly to the designs of Ninian Niven. Niven was a highly important state gardener, who was responsible for many other works around this time in Ireland. He was the curator of the Irish Botanical Gardens up until 1838, where he is credited with developing the shape of those gardens. He designed The Iveagh Gardens, described as among the finest and least known of Dublin's park and gardens in 1863. Undoubtedly one of Ireland's important horticulturalists of that era, Niven's is the founding vision on which Phoenix Park continues to model itself. The tree design around the Visitor Centre and Walled Garden has been restored to the designs of Niven. The People's Flower Garden is a 22 acre flowered spectacle, and forms the 'principal public horticultural display area of the park' (Management Plan, 2004). These gardens are maintained with as much use of Victorian planting styles and plant varieties as possible (Superintendent, 21st June, 2005), and are described in the Management Plan as an 'opportunity to demonstrate Victorian horticulture'.



Picture 6.5 The People's Flower Gardens

²⁰ The Park was designed originally using a French design, with goosefoot feet type layouts (interview with Architect)

Despite the history of the landscape and architecture being confined to a period beginning in the mid-1700s, there is a history of the Park which goes much further back. This history gets mentioned in the Management Plan, though more interestingly has a large display in the Visitor Centre (see Chapter 8). There is an archaeological site in the Park called the Knockmaree Burial mound, located close to the Chapelizod Gate and the Cara Cheshire home. This mound is dated at 5,500 years old. It was discovered in 1838 and is a composite mound dating to the Neolithic and Early Bronze Age periods. Small mounds were also visible around the tumulus in 1838, though these are no longer present. In addition to this mound, there is a megalithic chamber similar to the Knockmaree one in the Dublin Zoo, where it was moved during gravel excavations from the now disused Chapelizod pits within the Park. The Knockmaree mound, one of the oldest sites in Ireland, is not a focal point of the Park. Positioned near the Chapelizod Gate, it is removed from the Victorian splendour of Chesterfield Avenue. Temporally, it does not fit in with the blueprint of the park, and as such it is not featured in any of the tourist literature about the Park. The inclusion of it in the Visitor Centre is outstanding. The video display begins by saying,

‘The story of the PP starts in pre-history at a time when man first walked by the banks of the river Liffey. A small hill hides a burial chamber from 3500 BC older than the great mound at Newgrange, land considered sacred by our earliest ancestors. Thousands of years later, the Vikings used the area for the largest Viking cemetery outside Scandinavia.’

The video then goes on to talk about the Duke of Ormond, and the ‘founding’ of the Park and this history is not revisited or discussed in relation to the contemporary Park.

On the Phoenix Park map (see Appendix 2) the mound is shown in small font, with the Knockmary Lodge and Hill being designated far more prominence. Indeed, if you were not looking for the mound it could easily be missed both on the map and in presence. There is a heritage trail sign on the hill above it, beside the road that joins the Chapelizod Gate to Chesterfield Avenue. Even more hidden, is a megalithic tomb known as a Kist on the hill above this mound. This ancient burial site is not signposted. This kidney shaped tomb has cracks along

the surface which have been restored at some stage, and the restoration is now coming apart. In addition there is now a concrete support under the tomb.



Picture 6.6 Knockmaree Burial Mound

In addition to these historic points of interest, there is the largest Viking burial ground outside of Scandinavia. This was found on the Phoenix Park side of the River Liffey opposite the Islandbridge/ Kilmainham cemetery which dates from the 9th Century. The extent of the Viking cemetery is unknown. There are no signs or indications at the site that this has occurred, though it does get mentioned in the video display in the Visitor Centre. There is one reference to a megalithic burial Kist in the Phoenix Park in Dublin tourist information, which places it near the Knockmaree Burial Mound, though on the other side of the road, and behind the Knockmaree Lodge.

These aspects of the Park's history are not celebrated in the same way as the 1750 – 1880 period, which is given primacy over other epochs in the Parks development. The gas lamps and signposts which line Chesterfield Avenue are made to look as if they are from this specific time period. This is notable not only in the visual demonstrations but also in the general attitude among the staff in the Park. The Chief Superintendent has led this, and it is noteworthy that his official history of the Park focuses, with the exclusion of all else, on that time frame. In his interview he says, 'Before Decimus Burton? I'll tell you what it was, a disaster area, it was a swamp. Badly drained, poorly lit, robbers in it, in fear of your life.' (Chief Superintendent, 13th December, 2005: lines 156 -158) Following Decimus Burton's influence was when the Park was at its best, he argues, and thus it has been frozen in time at this point. It required little work to

bring the Park back to this timeframe after it had been neglected up until the 1970s. The major work had already been carried out during it and didn't need to be altered; the main avenue was straightened, it had zigzagged through the Park prior to that, and there was substantial planting. At this time it moved from being a hunting park that allowed grazing to supplement incomes, to a planned, developed Victorian park. This has caused antagonisms between his position and other people connected with the space who feel that this is not the only course of action which can be taken or that this is the only period of the Park that should be celebrated. A particular point of conflict was the Visitor Centre, where the building of a new section provided a point of antagonism between two key people. This antagonism is discussed in the Chapter 8.

Through the construction of the Park's historical façade to this replication of a certain period there is a certain parody involved; we are made to believe that this is the 'authentic' Phoenix Park whereas instead it is a representation of one way of thinking and acting informed primarily by a personal preference for aesthetic and ideals. Ideas of façade are important in the city as Zukin (1991) highlights in her discussion of Disney World. Through this discussion, she identifies the important power issues associated with the façade and the ways in which this can be harnessed. Inspired by the postmodern synergy between landscape and vernacular, Zukin focuses on Disney Land as a landscape explicitly produced for visual consumption. This in itself does not distance it from the other 'landscapes' she discusses (the Inner Landscape, the Mill and the Mall, Steeltown, Downtown), but the self-consciousness which accompanies this production marks it apart.

This has obvious resonance with Phoenix Park as a produced landscape which is a tourist attraction predominantly due to its visual appearance, and as so this appearance is perpetuated quite purposefully. Returning to Disney Land, Zukin (1991) observes that it was Walt Disney's original ability to abstract the desires of the powerless from the vernacular of Main Street and the Midway, and project them as a landscape for mass visual consumption, thus mapping a new vernacular image of a postmodern society. This was a stage-set landscape (Zukin, 1991: 231), a liminal space between nature and artifice and market and

place. It mediated between producer and consumer, a cultural object with real economic effect (Zukin, 1991: 231). As such, Disney Land, and the associated parks, have become models for establishing both the economic value of cultural goods and the cultural value of consumer goods. These landscapes, Disney Land and the World of Coca-Cola are the examples used by Zukin; position an established consumer product in a narrative framework that renews its cultural legitimacy through narratives. As art museums have replaced their encyclopaedic manners of display with story-telling strategies, in the same way these stage-set landscapes use narratives of legitimation and consumption to provide the visitor with a sense of place. The various techniques used to convey the history of Phoenix Park as a space and as a part of Irish identity are discussed in Chapters 7 and 8. The legitimating of a certain authenticity that is performed in Phoenix Park undergoes a similar process to that which Zukin describes; the landscape of Phoenix Park positions an established historical product (established through the legitimating practices put in place by the Parks management, residents, Visitor Centre and tourist literature) in a narrative framework that renews its cultural legitimacy through narratives. This begins to indicate the authenticity processes that occur through the narrative of legitimation offered to the visitor, management, resident and historian of the Park.

8. Reconstructing the Authentic

This idea of authenticity needs to be developed, as it is important to the ideas that are being looked at in this thesis. Ideas of the authentic become important when looking at ideas of culture and postcolonialism due to the different ways the authentic is used to justify different courses of action relating to the colonising process. In addition, the idea of the authentic comes into force in the post-colonialism time, when ideas of a culture prior to colonialism are often invoked to develop a nationalism and idea of nation that existed before, or beyond the colonial process. The teleology of colonialism suggests that authenticity will be reclaimed as part of the '[bringing] into existence [of the] history of the nation', which Fanon sees as crucial in the process of decolonisation (Fanon, 1961: 40). Authenticity can be used as a tool of coloniser to justify the colonising act, as David Lloyd suggests, 'On the side of the colonizer, it is the inauthenticity of the colonized culture, its falling short of the concept of the human, that legitimates

the colonial project' (Lloyd, 1993: 112). Through this process authenticity is elevated to the status of 'evaluation ethic' (Graham, 2001: 132), a central component of the ethics of colonialism. This 'ethic' supposes that the coloniser's culture and way of live is somehow more 'real', more 'authentic' and definitely more developed than that of the colonised, and as such can legitimately, ethically, disregard the other culture.

It is the way in which claims to authenticity change which underpins Graham's (2001) discussion of its relationship with Irish culture, and this section will discuss some of the main points made. This is relevant to Phoenix Park as a site of Irish culture and because it has become one of the main marketable aspects of the Park – an authentic seventeenth century deer park, an authentic example of Victorian planting and an authentic tribute to the history of the Park. This needs to be positioned in relation to authenticity in Irish culture, and to examine if, as David Lloyd (1993) suggests, it may have both a typical and particular function in the context of Irish culture and the chronologies embedded in it.

This is not to suggest that authenticity has followed where Irish culture has led, ideas of authenticity have underpinned ideas of Irish culture since its prevalence, making it indistinguishable from ideas of Ireland and the culture which is there today. As Graham discusses, 'a focus on authenticity takes us to the verge of seeing Irish material history as an unravelling backwards in time, detecting signs which plough against the linearities we know from political history' (2001: 135). In this way, tracing the ideas of the authentic requires a retrospective gaze to try and identify the influences which led to the emergence of the concept of authentic, while they are being continually wiped out by the processes they produced. The authentic cannot be seen as having a moment of construction, as it moves beyond that into claims of naturalness, an expression of the 'real', the obvious. These ideas underpin the idea of the nation, the very reason for its being, its logic of existence, is its claim to an undeniable essence as a pure expression of the 'real'. It is partly out of a way of replicating this essence that authenticity arises as a way of facilitating yet controlling the replication of a singular essence (Graham, 2001: 134).

Graham (2001) has highlighted this important place occupied by ideas of the authentic with relation to Ireland, examining the role of authenticity as it appears as a factor in Irish cultural production. He focuses his paper on the shift between ideas of the authentic being a signifier of the colonized's cultural incapacities, to being a marketable sign of value (2001: 59). Graham classifies authenticity in Irish culture under three headings; Old Authenticities, New Authenticities and Ironic Authenticities. These distinctions are based not on colonial/ post-colonial chronology, but on the point at which an 'authentic' Ireland becomes more or less available apparently outside or in defiance of colonial dominance.

When applied to Phoenix Park, this chapter argues that the idea of the authentic can be evoked to justify, to the point of the exclusion of other teleology's and histories, a particular concept of the Park. The ideas of founding moments can be problematised through recourse to ideas of subaltern histories and dominant voices (Spivak, 1990), and, as such the idea that the search for the authentic can have a line drawn under it to mark the beginning of this search is intensely problematic. To chase authenticity is to trace the origins of something that will always let us know that it has another origin further back. As another thread in this section, the idea suggested by Gareth Griffiths (1994) that the coloniser could still undertake the authorisation of authenticity after decolonisation, as a hierarchising form of control in the postcolonial period is developed through examination of the empirical data from the Park. Griffiths is writing about the Aboriginal experience in this piece which suggests that the inauthenticity once used to label the colonised, and which should have been subsequently reversed by anti-colonialism (as Fanon would suggest), has transformed into an authenticity which is under the control of the 'West'.

Applying this to the Irish system, Graham (2001) problematises it by recognising that the interchanges between Britain/ England and Ireland both during and after colonialism were never as settled or monolithic as Griffiths (1994) suggests they were and are an Aboriginal experience. Because of the proximity, geography, race and religion the position of the Irish in colonial discourses was and is liminal; Irish culture is at once western and colonised, white and racially other, imperial and subjugated, became marginal in the sense of existing at the edge of

but within two experiences, with a culture that epitomises the hybridity, imitation and irony latent in colonial interchanges. The position that ideas of authenticity occupy within this relationship is something key to this chapter, and is one of the major themes to have emerged from the empirical data.

Authenticity is found in the writings of many philosopher/ sociologists (Golomb, 1995; Adorno, 1986; Baudrillard, 1983) and sometimes specifically postcolonialism (Griffiths, 1994). Golomb (1995) views authenticity as a way of guarding against the undermining of our 'true' selves by the impulses of the postmodern, arguing nostalgically for an authenticity which is actually reliant on nostalgia for its very definition. Adorno (1964) examines the point that the authentic is socialised and popularised, and he uses an analysis of authenticity in and as a language and as an ideology to develop this. Adorno sees authenticity as a jargonised system, falsely constructing itself as essence and origin. His problems with authenticity are also extended to the issues of exclusionism that are inherent in the system, identifying what is outside it,

“'inauthentic', where something broken is implied, an expression which is not immediately appropriate to what is expressed ... 'Inauthentic' ... becomes a 'critical' term, in definite negation of something merely phenomenal.”

(Adorno, 1964: 7 – 8)

Authenticity is then recognised as being part of an ideological project, one which is exclusivist, evaluative and almost a means of defining what is superior and heroic. Adorno then develops the concept of authenticity beyond a cultural ideology but as a way of thinking and being,

‘Whoever is versed in the jargon does not have to say what he thinks, does not even have to think it properly. The jargon takes over this task and devalues thought. That the whole man should speak is authentic, comes from the core... Communication clicks and puts forth as truth what should instead be suspect by virtue of the prompt collective agreement.’

(Adorno, 1964: 9)

Adorno's critique of authenticity hinges on disrupting the edges of its claims to wholeness and organicism, and its ability to become a self-sufficient ideology and way of speaking. While this approach is moving towards something which can be used in this thesis, it is necessary to identify that underlying Adorno's

discussion is the idea that authenticity is a dispute over possible truths. To problematise this, it is important to look to Baudrillard and begin to deconstruct this idea of authenticity to a further degree. Baudrillard sees authenticity adopting a role in the fantasy of representation,

‘When the real is no longer what it used to be, nostalgia assumes its full meaning. There is a proliferation of myths of origins and signs of reality; of second-hand truth, objectivity and authenticity...there is a panic-stricken production of the real and the referential, above and parallel to the panic of material production’

(Baudrillard, 1983: 12 – 13)

According to Adorno, authenticity ceases being a measurement of value and becomes a sign of the need for such values. In the midst of apparent breakdown associated with the postmodern project, authenticity reverts to the (re)production of origins and its values. And this can be viewed in relation to the Park and its transitions between the traditional and the modern, and potentially between the modern and the postmodern. The transition between traditional and modern, and modern and postmodern would appear to give rise to issues, similar to those identified by Baudrillard, in the context of Ireland especially if this transition is read as being synonymous with issues of colonialism and postcolonialism. Issues surrounding self-identity, important in Golomb’s treatise on authenticity, can be uncovered during the transition between colonised and independent Ireland.

9. Packaging the Authentic

The discussion on authenticity is important in relation to the Park, as there is an overriding discourse which dictates and constructs the Parks content and image, which makes recourse to an idea of the authentic. While it is apparently all encompassing, there are cracks in this discourse which allow us to understand it further. In the interviews there were varying levels of awareness or willingness to disclose the presence of these discourses. The Head Guide was reflective in her awareness that the Park provided ‘little packages’ (8th May, 2005: line 44) of the history of the Park, which they ‘break ... up into different levels’ (8th May, 2005: line 89). She spoke repeatedly about the idea of a ‘package’ which was tailored to the visitor, and was aware that certain guides tailored these packages in

different ways, each providing their own ‘slant’ (8th May, 2005: line 107) on the history of the Park. She was in the process of completing a degree in History, which had provoked her to think about the ideas behind history and specifically Irish history. This discussion included a very reflective piece on how she had grown up in Ireland, which was strongly linked with an idea of Ireland developing. This progressed to a discussion on the ways in which history was represented and used in Ireland, as a way of understanding our colonial past but also searching for something else, another form of Irish identity. This brought the discussion back to the idea of a slant, and she said,

‘Being brought up in a Catholic school system where we were told to actually hate the British in one sense and yet were being taught the Catechism by the same teachers on the other hand and it’s not you don’t know any different as a child so you just take this on board until you actually think for yourself and are allowed to think by yourself as an adult that you realise that the individuals concerns slant on things are actually being conveyed into the children in the class through a process where these ideas were being pushed on children in the class’

(Head Guide, 8th May, 2005: lines 294 – 299)

The advent of television was heralded as a changing force, a way of opening up questions and empowering people. This provided a ‘portal’ (8th May, 2005: line 368) which was opening onto a new way of seeing Ireland, and this was intrinsically linked with questioning and demanding answers to these questions. As linked to this was the increase in an idea of the past, she tells a vignette about her husband travelling to Newgrange, one of the most popular tourist attractions in Ireland. In addition to that, it is epitomised as an important site of a Celtic past with all the mysticism and wisdom which that encompasses. To visit Newgrange now on the Midsummer’s Day equinox requires you put your name on a waiting list which stretches to ten years²¹. The Head Guide recalls her husband’s experiences, signifying the shift between his and her generation and her parents,

‘In the 70s my husband remembers going on the 21st of June, which is the biggest day in Newgrange as you know, he remembers going up with his friends on the back of a motorbike in around 1976, and going up there to be there on Midsummer’s Day and nobody being there. Nobody was there. And the old monument overgrown and this sense of this hasn’t been touched, like nobody has interfered with this since 5000BC, and a wonderful sense of being there at

²¹On this day, there is a beam of light which travels through this ancient stone mound and directs the visitor into the main chamber.

that moment and knowing how relevant it was, and again that would have come from education. I mean my parents wouldn't have known about Newgrange, I mean why would they need to know about that when what they need to know from the age of 14 is how to earn a crust of bread.'

(Head Guide, 8th May, 2005: 375 - 384)

This account highlights the relationship this person has with the idea of history, and how it is linked with a search for knowledge. This can happen, she explains earlier in the interview, only when there is a shift from a more traditional society, where education is not seen as important to a more modern society characterised by questioning and the quest for knowledge. But this is linked with the loss of an idea of self, linked with work and, essentially, survival, to a search for something more, a sense of Irishness which goes beyond that. She equates this with the need for answers, but also the 'portrayal' of history as final, or as having one reading. The need for a 'package' of history, and a way of this fitting in with the consumers need for it to relate to them, means that places like Phoenix Park and Newgrange are required to present a certain story to the public. As the Head Guide describes,

'And I think any group, be it OPW or whatever, who will push that boundary [of what is factual] and say this is what our identity is em you know and they're washing it over people for them to absorb it, it's not necessarily true.' (Head Guide, 8th May, 2005: lines 389 – 91)

'I felt that overtime someone had come along to Newgrange with their slant, and it's not always correct. I mean that's happened to a guide at the end of last year who had been for a long time at Newgrange, and some stuff that this archaeologist could throw up and tell us in relation to Newgrange she had never known, being a guide on Newgrange for ten years. You know, about skeletons being found outside the structure and that sort of thing. You know, and she was astounded. So who put the identity of Newgrange that she had? Who put the slant on it?'

(Head Guide, 8th May, 2005: lines, 402 – 5)

She is aware of the process through which these sites become tourist attractions and are able to facilitate visitors, and how much of the time this is done by 'whoever is there on the site' History is all about questions, and by having to produce an exhibition the trend is to ignore many of these questions, out of both necessity and simplicity and present a 'story' of the site which is easily accessible and relatable to the visitors. The exhibition in the Visitor Centre is the same; indeed the need to replace the displays was highlighted by the Head Guide

and the Superintendent as of the utmost importance for the Centre to ensure that they presented the information in a contemporary, accessible way. The manner in which these displays were constructed highlights many of the issues raised by the Guide; though also provide a focal point of antagonism within the Park. The centre itself was a site of antagonism, and the displays within them were an additional layer of dispute between competing discourses of the Park. Both these antagonistic issues are developed in Chapter 8.

The idea of authenticity and originality is used repeatedly in the Management Plan as a way of describing key objects in the Park. The lighting in the Phoenix Park is of special note, as it is one of the few remaining public areas in Europe which still relies on gas for public lighting.



Picture 6.7 One of the types of lamp posts in the Park



Picture 6.8 Lamp with Phoenix Park sign underneath

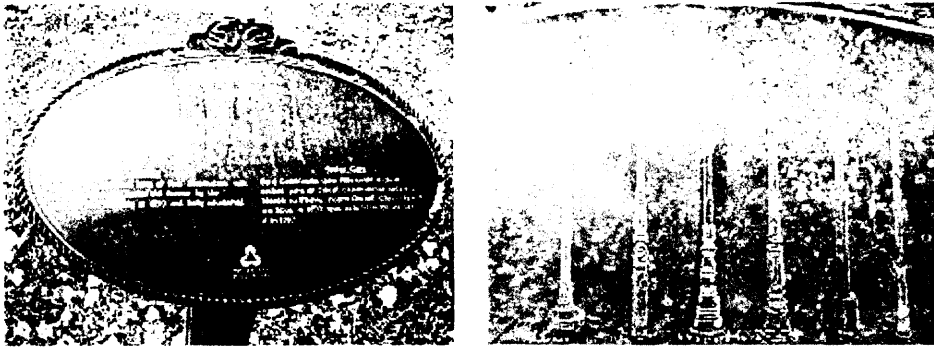

Picture 6.9 Display in the Park about the lamps

Gas was first used in the Park in 1859 by the Hibernian Gas Company and is prominent through the Park. The lighting is described by the Management Plan as a ‘major visual element in the Park’s landscape’ (Management Plan, 2004: 12). The lighting was fully refurbished in 1987, preserving the historical look of the lamps and their gas use. There are six different types of light in the Phoenix Park, as can be seen in Picture 6.8 of the display on the lamps that is located on Chesterfield Avenue. The lamp in the second picture on the previous page, which says ‘Phoenix Park’ on it, is found around Áras an Uachtaráin. The lamps which line Chesterfield Avenue are less ornate, and are painted black in contrast to the other lamp’s whiteness. The other lamps are spread through the Park, with different sections comprising of different lamps. These lamps are spaced evenly along Chesterfield Avenue, giving the historic feel to this road, and providing a separation between the road and the open land on either side of it. This historic feel is continued with the iron railing that runs between the road and the lamps and the cycle path and footpath. Along Chesterfield Avenue this is painted black, though around Áras an Uachtaráin and the Visitor Centre these railings are painted white. The railings around the Ordnance Survey and the Garda Barracks are the standard black. The signposts in the Park are a mixture of ‘original’ and replicate. These are black and white with scalloped edges. They are written in both English and Irish, with the Irish language being written in a different, older looking font than the English. The ideology underpinning this dedication to the idea of ‘original’ was summed up by the Superintendent,

‘The lamps are all an original design, and they’re actually gas, on the main road, they’re all gas, and, you know, to keep it historical you know we don’t want it all lit up like a municipal area, it’s meant to be a park. And ... a lot of times there’d be pressures to put in a load of electric lights and you could see, but we

... don't want to do that. Like the buildings, any of the buildings here that are restored are restored back to the original ... Like even to the level of plants that we would use, we would use bedding plants, Victorian bedding planting schemes. And the gardeners would all be trained on the historical way of doing things. We might use modern varieties, but it would look how it looked in the 1800s...But that's our ethos and that's how we very much do it, go back to the original, the original. And if we can't restore it we won't do it differently, we'll leave it and we'll preserve it so that it doesn't deteriorate further until the time is right and the money is right.'

(Superintendent, 21st June, 2005: lines 362 – 382)

This quote highlights these issues relating to authenticity, and the ambivalent relationship held by the Park management to ideas of originality and authenticity. This idea of recourse to the original is of course problematic, and even in the above quote the example of the Victoria bedding plants begins to demonstrate that. These are not *the* original but imitations, facades and reproductions that no matter how sympathetic and similar to the originals are in fact ideas of the past that have been socialised and popularised. Following Adorno, in this postmodern time, authenticity reverts to the reproduction of origins and values demonstrating some form of legacy that is in fact a fallacy.

9. Conclusion

The Management Plan divides the management objectives into five key points, which are, in order of priority; Conserving the Historic Landscape character; Recreational use and public appreciation; Conserving Natural and other Park Values; Education and Research; and Local Communities. These objectives can be seen to influence the way the Park is projected and understood. The idea that it is a historic landscape that must be conserved brings in the ideas of authenticity that have been discussed in this chapter.

Following Graham's (2001) discussion of 'the Irish case' and the trope of authenticity, this chapter argues that the authenticity is only ever 'reproduced, filtered and reconstituted through a process of authentication and recognition of status' (Graham, 2001: 59). The Park provides a 'supplement of commentary', a discourse that authenticates the authenticities, around the different 'authenticities' that it displays. If, as Graham argues the 'colonizer denies authenticity, then for Irish culture it becomes crucial that the birth of authenticity

is rooted in revolution' (Graham, 2001: 60), the Park does not fall into this category of Irish authenticity, as its claims to authenticity are rooted in continuity rather than revolution. This chapter suggests that the authenticity invoked in the Park is more in line with the claims by Gareth Griffiths (1994) that the coloniser can still undertake the authorisation of authenticity after decolonisation as a hierarchising form of control in the postcolonial period. There are power structures and ideas which shape the narratives of understanding in the Park that are influenced by a continuation of power structure that exist as after-effects of colonialism. It is here that the idea of liminality is needed to understand the Park and Ireland, and Griffiths' one-way process of cultural control fails to develop on the complexity in this instance. While there have been anti-colonial stances in the Park, predominantly religious events and mass gatherings which have tried to project an idea of Irishness that is removed from the colonial history of its situation, the Park has not moved away from the function and aesthetic that was provided by the colonisers. Ideas of what is good in the Park are also intimately tied to this ideological position, such as the landscaping and preservation of the buildings. The packaging of authenticity for an audience is an important part of this discussion; the Park management are self-conscious in their choice of what story to present, because this allows the visitor to relate to it. However, it is unclear what the visitor is able to relate to in this Park, as opposed to, for example, the history of Newgrange as told by the Head Guide.

There is a sense of authenticity on display in the Park; there has been a space preserved so that it can be visited. What is on display is not modern, new Ireland but a frozen older Ireland, one that makes claims to authenticity that exist in the liminal space that the Park occupies; it is at once demonstrating a claim to authenticity that can be found through recourse to colonial ideas and at the same time demonstrating breaks from that discourse through the demonstration of Irishness discourses. The next chapter will look at the discourses of Irishness that are demonstrated in the Park, how they exist in the contested spaces and terrains of Phoenix Park. This will look at the different uses of the Park and the way this is incorporated into the understanding of what the Park is, and how the space should be understood.



Chapter 7: Ideas of Irishness and Mass Events

1. Introduction

This chapter examines the idea of ‘Irishness’ and how particular events within the Park can be understood and lead to understanding around this nebulous concept which is pervasive in discussions of Irish identity, but sparsely interrogated in empirical investigation. This chapter unpacks this idea with recourse to important events in the Park, using the Pope’s visit to signify a particular epoch of Irishness and juxtaposing more contemporary events with it to provide an understanding of the idea of Irishness today. As part of this, there is a problematising of the over-arching idea of *one* Irishness, showing that Irish society lacks the cohesion, unity and singular vision to be easily classified and instead is constituted by many local, contingent identities that come together in a collage of contemporary Irish identities. There are complex historical, social and political relations occurring on the national and local levels, and as such the chapter investigates the different complexities associated with ideas of nation and nationality as expressed through events in the Phoenix Park.

This chapter builds on the theoretical discussions in Chapter 2, and the empirical work in the previous chapters, by taking the themes of Irishness and working through empirical data relating to it in the Park. The chapter then continues on to the main events in the Park, working through them chronologically to provide a changing image of Ireland through the Park, or the Park through different Irelands. The idea of national identity is something examined and problematised in this thesis and this chapter highlights this ambivalence and liminality regarding the various constitutive parts of the nation and ideas of nationality.

2. Ireland and Irishness in the Park

In *Inventing Ireland* (1996), Declan Kiberd posits that Ireland was invented through three separate strategies. This trinity comprises, first, of the Irish, as a

historical people but also as a nation which can continually reinvent and assimilate new elements through different phases. This has been discussed in Chapter 2, and will be woven through this chapter as well.

The second composite is the English, who developed Ireland as a fantasy-land with fairies and monsters (Connolly, 2001). Ireland has both embraced this and reacted against it, embodying the hybridity of Bhabha in this split moment. Kiberd (1996) describes how a veteran of the 1916 Rising recalled, in his old age, how he felt the Rising would 'put an end to the rule of the fairies in Ireland', but how this project was notably unsuccessful. This process was not one-way; England and ideas of Englishness were not unaffected by the colonising project, but the process also occurred in another way. For the Irish, England became a 'fairyland', a term developed by Oscar Wilde who saw the nobility of England as being as exotic as the Caliphs of Baghdad (quoted in Kiberd, 1996: 2). Folklore is an important element in the Irish story; it provides an alternative way of knowing than that of the colonialist; a way of knowing that has been displaced by more scientific knowledge. The folklore of Ireland provides a magical understanding of nature, the land and the interaction between culture and nature. The 1916 veteran wishing for the eradication of fairy rule in Ireland was calling for the adoption of a different epistemology, a more 'modern' knowledge system that would break this fantasy lineage. However, myth is more than simply a few tall-tales.

The re-appropriation and acceptance of this legacy allows different relationships with nature and history to exist and be accepted. The hybridity of the Irish reaction is crucial here; while on one level there is a conscious rejection of the folklore stories, on the other it forms an important part of Irish life. This has been developed further by the growth in Irish tourism that uses this folklore as a marketing tool. The leprechaun and the Celts are promoted as symbols of Ireland, despite the leprechauns supposed pre-dating of the Celts. In politics, leprechauns have been used to refer to the 'twee' aspects of the tourist industry in Ireland. This can be seen from this example of John A. Costello addressing the Oireachtas in 1963,

‘For many years, we were afflicted with the miserable trivialities of our tourist advertising. Sometimes it descended to the lowest depths, to the caubeen and the shillelagh, not to speak of the leprechaun’

(Costello, 1963)

The third and final strand in the trinity of Irishness discussed by Kiberd comprises of an idea of Ireland, the idea which is shouldered by those who exiled to Britain, North America, Australia and everywhere else that the Irish have moved to. The dreams these people hold of their homeland, the idyllic and idealised ideas of Ireland and what the associated tenet of Irishness meant form an important composite of what Irishness means. The Irish diaspora is widespread, and the idea of the returning émigré occupies an important place in Irish culture. In fact, Mary Robinson the president of Ireland from 1990 to 1997, placed a candle in the window of her official residence, *Áras an Uachtarain* in Phoenix Park, reminiscent of the Irish tradition of a candle in the window on Christmas Eve to light Joseph and Mary to the inn, and meant to invite the Irish emigrant home.

3. Events in the Park

These three strands will inform this section on ideas of Ireland and Irishness that can be found in Phoenix Park. This will be concerned with expressions of Irishness through the different epochs in the Park’s history, and will situate these expressions in the wider social context out of which they arose. The section will be primarily chronological and will position the events in the context of ideas of the postcolonial, and the notion of the ‘invention’ of Ireland and Irishness. This will involve looking at the social, political, cultural and economical issues around these events. The impact of mass events in the Park will be looked at, as they constitute a means of charting the changing use of the Park. By moving through different uses and events in the Park, it is possible to see the changing societal relationship with the space. The reasons behind these changing relations are useful to allow insight into the society that is emerging and the place the Park holds in it.

3.1 The Park as a Stage

The different uses of the Park through different epochs are evoked in this chapter to develop an understanding of different types of Irish identity. This first section breaks from the chronology of the rest of the chapter to present a short account of particular acts of dissidence. These are examples of where the Park is used to stage protests. In so doing, the Park is shown as an important site where symbolic violence is used to counter prevailing discourses.

In 1780, around 100,000 people attended the Park to see the Irish Volunteers²² (Province of Leinster) review under the flag of ‘Loyal and Determined’ (Nolan, 2006). Following this military tradition and because it was close to the military barracks, throughout the nineteenth century British military reviews were conducted in the Park. Tens of thousands of people would come to Phoenix Park to witness the spectacle of the brightly coloured uniforms and well-turned-out military formations complete with charging cavalry, regimental bands and impressive weapons. This display had the dual purpose of impressing and intimidating the gathered crowds with the pomp and majesty of the Empire providing a distraction from the role of the soldiers and their purpose in Ireland and throughout the colonies. However, the spectacle did not divert everyone from the military work these soldiers were in Ireland to carry out, and there were many reactions against their presence. Notably, in August 1871 a Fenian amnesty meeting took place in the Nine Acres, the position of the present polo grounds, with over 5,000 people in attendance.

The meeting was called to apply pressure on the Government to release Irish prisoners who had been captured in the failed 1867 Fenian uprising. This meeting was designed to coincide with a visit to the Park by the Prince of Wales and members of the Royal Family who were staying at the Viceregal Lodge. The police charged the meeting, which had been forbidden by the Under Secretary, and caused considerable damage to the protestors. The force with which the police used to disrupt the meeting was out of proportion to the threat it posed, but

²² The Irish Volunteers was a part-time military force raised by local initiative during 1778-9. Their original purpose was to guard against invasion and to preserve law and order at a time when regular troops had been sent to America during the War of Independence

it was a clear demonstration that the British would not tolerate acts of dissidence, especially in the Phoenix Park which was so important politically and symbolically. Similarly, in 1875, at an event organised by the Dublin Total Abstinence League condemning the sale of alcohol in the Phoenix Park²³, the police reacted violently and without restraint because of the large crowd that began forming. Following the 1867 event there had been recognition for the need to facilitate meeting without attack by the police, but this was ignored in 1875. The 1875 meeting was the last to be broken up with such force.

The Park has been the site of different expressions of this dissidence from British rule and also events which have been used to express ideas of Irishness both during and following the official tie to Britain; there have been events in the Park which have shaped the political, and concurrently social, climate of Ireland. The following section looks at some of the main events as described by the Park management and OPW and that have been preserved in the public memory as notable and influential. This chapter presents a historical-social account of these events, in Chapter 9 this is developed from a different perspective.

4. The Phoenix Park Murders

On the 6th of May 1882, members of the Invincibles, a Fenian terrorist splinter group, stabbed the Chief Secretary, Lord Frederick Cavendish and his Under-secretary, Thomas Burke to death with surgical knives within sight of the Viceregal Lodge. The political situation at the time in Ireland was turbulent, and there were allegations of involvement directed at the figurehead of the Irish nationalist movement, Charles Stewart Parnell. Parnell was a popular and influential politician of the time, involved with the Land League, an organisation which held as its central tenet the desire to provide tenants with a fair rent, fixed tenure and free sale. This organisation called for a Land Act, which, among other things, Parnell saw as the first steps towards Home Rule. The Land League taught the Irish farmers to assert their rights and combine their forces. Gladstone became Prime Minister for the second time in April 1880 and hoped to pass an emergency Land Bill through parliament that summer. When it was defeated in

²³ In Phoenix Park on a Sunday at the time up to 300 tents could be pitched across the Fifteen Acres for the sale of whiskey and for gambling (Nolan, 2006).

the House of Lords, the Land League embarked on a campaign to reinforce the need for this political reform. The events in Phoenix Park did not have immediate or obvious political ramifications, though they could easily have upset the Irish struggle for a Land Act and subsequent Home Rule, and could have led to Parnell's demise. Some believe the reaction in Ireland and Britain may have set back the cause for Irish self-government by some distance as the societal acceptance of these acts was very low. This influenced the way people working towards independence and self-governance were perceived in society. As Corfe (1968) describes in much detail there were many acts of retribution that followed the murders.



Picture 7.1 The Visitor Centre display on 'Murder in the Park'

The story of the murders told in the Visitor Centre describes the event as tragic, and recognises the potential disruption it could have caused between the English Parliament and Irish nationalists. Relations had been improving up to this point, and this event could have potentially heralded a return to the oppressive regime of colonialism which had been in place as signified by the 1875 actions against protesters. The Park display notes how widespread denunciation by the nationalist leaders, coupled with the recognition that the 'tragic event was an overflow of the previous coercive policy of government' led to restraint on 'both sides'. On *Today with Pat Kenny*, an Irish radio show, on the 3rd January 2006 there was a segment on the Phoenix Park. The murders were described as being one of the most influential occurrences in Irish political history, and were 'very powerful'. The analogy used to make it relevant to a contemporary Ireland was

the Taoiseach and Tanaiste both being killed in a single day, and to translate that to a British analogy it would be as if the prime minister and chancellor were assassinated. It was noted that the act caused the death of the ten people involved (the people killed, and the people executed for the killing). This demonstrates the lasting legacy that this event holds for Ireland, as it was an influential factor in social attitudes towards British rule and acts of dissidence. With widespread condemnation of the action by nationalist leaders, there was a move towards peaceful methods and negotiation. This did not endure for the duration of the quest for independence unfortunately, but is an indication of relations between Britain and Ireland for this social and political epoch.

Interestingly, the death of Lord Cavendish has become a leading example of the idolisation of dead Victorian men for historians, and he featured prominently in a book concerning this subject (Jallad, 1999). As part of this, his death was understood in very specific terms; in the time following his murder, his image became an icon. The tragedy of his death was surpassed by admiration for his sacrifice, and he was awarded with praise for his wholehearted devotion to his cause. In a memorial sermon Lady Cavendish's cousin Reverend Stephen Gladstone proclaimed,

‘Oh, Irish hearts, he died for you, as well as by the hands of cruel men amongst you. Oh, English hearts, he died for the wicked tyranny, the awful selfishness, the bloody cruelty of many of your forefathers. Let both countries be conscience-stricken with a common shame and sorrow’

(quoted in Jallad, 1999: 326)

As a national sacrifice, his death seemed acceptable. Without having done much other than die (he was killed on the day of his arrival in Dublin), he was turned into a saint-like soldier who fought and died for his country. To some extent, the widow gained comfort from the symbolical significance of her husband's death. Immediately after his assassination her diary reads,

‘Across all my agony there fell a bright ray of hope, and I saw in a vision Ireland at peace, and my darling's life-blood accepted as a sacrifice, for Christ's sake, to help to bring this to pass’

(quoted in Jallad, 1999: 327)

Despite the importance of this man's death, as an iconic figure or as a 'saint-like soldier', the only official testimony to the murders and his death are in St. Margaret's Church in Westminster. In Phoenix Park, there are no official statues or memorials to the men, apparently at the request of the widow.

'But Lady Cavendish, said as soon as he was killed, that she didn't want any commemorative monument. Now, we've been criticised in the British Observer during Cultural Capital year because there's no monument there. But it's in her memoirs. Now, having said that, T.H. Burke who was the highest serving Catholic in the British Administrator he was Secretary here, his sister was a Dominican nun, they have erected a stain glass window and church down in St. Dominic's church down in the in Dominic St. And during the Troubles, they were worried about the plaque, and they switched the plaque down around the behind the, what do you call it, the upright pillar. They switched it around so it wouldn't be a focus. There's some other little monument to Burke somewhere.'

(Chief Superintendent, 13th December, 2005: 268 - 276)

However, there is an unofficial memorial to the murdered men in Phoenix Park. The thing of folklore, and something which was dismissed by some officials in the Park as myth, there is in fact a small cross cut into the bank of grass opposite Áras an Uachtaráin, where the murders occurred. The secretary at the head office in Phoenix Park jokingly described how she felt it was put there by taxi drivers in an attempt to increase business through tourism, and she recalls how she and a Park Ranger saw a taxi pull up opposite Áras an Uachtaráin, but didn't know if that was what was why.



Picture 7.2 The cross cut into the ground (red lines added)



Picture 7.3 Cross cut into ground, with Áras an Uachtaráin opposite (red lines added)

The Chief Superintendent was pleased to discuss the cross, something which had been one of the mysteries of the Park which had intrigued him. He had helped in its maintenance by cutting back the grass, and inserting wooden panelling to stop the grass growing over again. He added another layer to the story, by describing how each 6th of May a bunch of flowers was placed on the cross, in memorial of the men killed in the murders. After almost fifteen years of working in the Park, he had still not been enlightened as to who placed the bouquet there, and was recounting this tale to the Old Dublin Society in a talk about the history of the Park. At the end of this talk, a man came up to him and told him that it had been his family doing this since it had occurred. As he describes;

‘Now I was giving a talk at the Old Dublin Society, this guy that was actually chairing the meeting, he said I beg your pardon, and I said we suspect it’s a taxi man to boost the trade, and he said I beg your pardon, it’s been my relatives that have done it for three generations, and now my grandkids are doing it. And I said that’s amazing stuff, and I said how did that start? And his great-grandfather was on the three-wheel bicycle [who found the bodies], and having witnessed what happened, he undertook to commemorate it some way.

[...]

So your man, a nice guy, Carrey from Fishamble St, and I was coming through the Park a few years ago on the 6th of May and I see another guy putting flowers on it, and so anyway, I said that’s not the guy and he was an old guy as well, and picked him up [in his car]. I said what are you doing? He said I’m commemorating the murders, and I said isn’t that fantastic. And I said but you’re not the guy, and he said it was his brother. And I went to the house, I live in the Park there, and I took a photo of the guy and we’d a cup of tea and a

sandwich, and coming back he said would you ever believe that a British Prime Minister would pass that spot on this exact anniversary, because Tony Blair was visiting Farmleigh on that very day. Amazing, I hadn't even twigged, but this guy had it in one, he was a doorman at the Shelbourne Hotel and he met all the high and mighty, terrific character. So I don't think that that is coincidence, it's just awesome. On the day, with a British prime minister. So Tony Blair, passed the spot that morning, and it wasn't lost on that guy.'

(Chief Superintendent, 13th December, 2005: 256 - 289)

The importance of the event for the men who placed the flowers and the Chief Superintendent is evident in the above quote. The Chief Superintendent feels that there should be a memorial there, though recognises the sensitivity of the event. He recalls how some of the Rangers in the Park had fought in the 1922 War of Independence, and would not refer to the event as the Phoenix Park murders, instead calling them the Cavendish Assassination. In addition, he says there are problems with putting 'contentious' things up on display, many of which are vandalised or taken away. As he describes;

'Now, we put a little timber surround on it [the cross], and we might put a second one there, something I suppose a bit off the record but eh there's a block of stone there and it has been damaged, and we think that's because someone thinks that's the marker, but it's only a marker for traffic. [...] And the self-guiding heritage trail, some of them have been stolen [...] and now we've knocked some of them down ourselves moving timber but some of the more sensitive ones have been stolen. And we haven't got around replacing them.'

(Chief Superintendent, 13th December, 2005: 291 - 299)

The people who hung for the murders were widely regarded as criminals whose actions were unreasonable and a disgrace to Irish society at the time, and this view predominantly continues in contemporary times²⁴. There were some press reports at the time referred to the Invincibles as anarchists and, allegedly, Frederick Engels called the Invincibles 'Bakunists' (Black, 2005). In London the short-lived German anarchist paper '*Freiheit*' (worker) shut down as a consequence of publishing an article 'applauding the assassination of Lord Frederick Cavendish by Fenians in Phoenix Park, Dublin, in May 1882' (quoted by Black, 2005). This account is taken from a report on www.indymedia.ie, which also includes an alternative account of the cross cut into the ground. The

²⁴ Contrary to this position, *The Blanket*, a strongly nationalist journal of 'Protest and Dissent', uses the Phoenix Park murders as a means of condemning the political relationship between the Irish and British at the time, and cites the Irish Republican Brotherhood as saying the people who carried out this 'execution...deserve well of their country'. (<http://lark.phoblacht.net/shadowgunman.html>)

account explains the cross in a different way, recounting how in 1938 James T. Farrell, the American novelist, came to Dublin to visit Jim Larkin, a prominent trade union and socialist leader in Ireland in the early 1900s. Farrell relates that while there Larkin,

‘asked me if I wanted to see the monument to the Invincibles ... I imagined that I was going to see a statue, but this did seem passingly curious. The idea that there would be a monument commemorating the Invincibles in Dublin didn't make sense. We stopped in Phoenix Park, just opposite the Archbishop's palace. ... We got out. Jim walked along a path, looking down at the grass. I was bewildered. Jim became nervous, and he stared on the ground with some concern. Then he pointed. There it was. I saw a little hole where grass had been torn up. A cross had been scratched in the earth with a stick. I gathered that many Dubliners did not know of this act commemorating the Invincibles. Jim's boys always went out to Phoenix Park, and marked this cross in the earth. No matter how often grass was planted over it, it was torn up. The cross was marked in the earth.’

(quoted in Black, 2005)

This account provides the alternative viewpoint that this cross is for the Invincibles and not for the murdered men. It would also seem to stand in contrast to the placing of flowers as discussed above. Nolan (2006) claims that nationalist historians place the cross there each year as a means of commemorating the event.

The Visitor Centre displays call it an atrocity, and highlight the potential for political unrest following the act. The Chief Superintendent describes the process through which this history was ‘selected’ for display,

‘...when we came to do the video here, so the guy [...] who was a forester but became an environmentalist and there was a Professor from Galway was the consultant. And he said we'll see what the papers of the day were saying, and that's what we went with and the kids were shouting stop press stop press murder in the park, it's more acceptable when you're quoting. So it was reporting on what was said back then.’

(Chief Superintendent, 13th December, 2005: 306 - 311)

This approach means that there is no reference to the cross on the ground, or the complex political and social reactions which occurred. By presenting what was said by the mainstream, British controlled press there is a denial of the alternative voices. The history of this event in the Visitor Centre does not present any of the contexts of the event; there is no historical or political debate

surrounding the cross, the murders or the legacy in Irish society. However, there is still a cross in the ground, and the Park management preserves it. As such, there is ambivalence towards this history in the Park. This ambiguity surrounding the cross demonstrates the contested terrains of meaning in Phoenix Park. The ‘official’ account is compelling; the Chief Superintendent maintains the cross and knows who places the flowers there. However, this does not mean that this is the only meaning associated with the cross, as demonstrated by the nationalist accounts and understanding of the memorial. The hybrid identity of this memorial is demonstrated through the alternative meanings associated with it, and the different symbolic position it occupies in the nationalist ideology and in the official Park’s discourse, as discussed by the Chief Superintendent. This account of the events and the memorial are used to demonstrate how the different readings and understandings of history and historical events can influence the way we understand the places in which they occurred and the marks on the landscape which they have left.

5. Religious Mass Events

On the 23rd of June 1929, thousands of people attended a Pontifical High Mass presided over by the Archbishop of Dublin, the Most Reverend Dr Byrne, in Phoenix Park. This mass commemorated the centenary of Catholic Emancipation in Ireland. The emancipation realised the end of the Penal Laws, an oppressive set of regulations governing the way in which the Catholics in Ireland were allowed to live and relegating them firmly to second-class citizens. This mass marked the first of a number of prominent Catholic events which occurred in Phoenix Park. Due to the constitutional links between the Roman Catholic church and state in Ireland which existed up until 1972 officially, when the ‘special position’ of the Roman Catholic Church was deleted from the Irish constitution, and continues today ‘unofficially’ with the State schools providing a Catholic ethos in education as one example of many, the events which occurred in Phoenix Park can be seen as a component of nation building and culture forming. Considering Ireland had only become the Irish Free State in 1922, a transitory position it occupied as a dominion state between being a colony and a Republic (which came about in 1949) the celebration of a mass for Catholic Emancipation was a loaded political and social action. This was a call

to the nation, through the State, to come together in this moment to celebrate the freedom of the Irish people, through the Catholic Church. Through these acts the place of the Catholic Church was reinforced in Ireland.

Another important meeting took place on the 23rd June 1932, when the thirty-first Eucharistic Congress took place in the Park. This important event again signified the emergence of Ireland onto a world stage, and the acceptance of Dublin as a city significant enough to hold such an event. The main gates and piers at Parkgate Street were moved to accommodate the movement of crowds. Following the event, these could not be found. After some searching, the piers turned up but the gates remained lost. It was only some fifty years later that one of the gates was found again, in a private residence in County Cavan. How the gates got there remains unknown to this day. Detailed drawings and measurements were taken, so that if the gates were replaced they would replicate the original, but due to the tourist buses and coaches they have not been restored, as it would impede the entrance. Tens of thousands of people took part in the procession across the Liffey and into Phoenix Park to hear a Mass lead by the senior Catholic Church leader in Ireland but it was overshadowing considerably by what came next.

6. The Pope's Visit

The Papal visit of 1979 marks one of the most significant dates in the contemporary Irish calendar. The large white cross which marks the spot from which the Pope addressed the gathered masses is still one of the most visited sites in the Phoenix Park, with the nearby car park providing a stopping point for tourist buses and coaches as well as the public who come to see the cross and the deer which are often found in the land behind it.

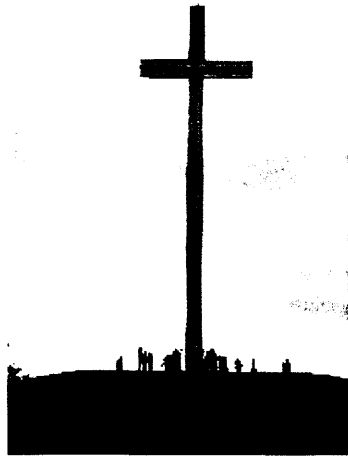

Picture 7.4 Cross with people and stairs leading up to it

On Saturday the 29th of September 1979 almost one third of the population of Ireland, an estimated one and a quarter million people, came to the Phoenix Park to see Pope John Paul II. Following the Phoenix Park mass, the Pope visited Galway, Drogheda, the Knock Shrine and Limerick, where almost all of the other two-thirds of the Irish populations attended. This was the first time the Pope had visited Ireland and the timing was important politically and socially.



Picture 7.5 Pope in 'Pope mobile' in Phoenix Park (courtesy of Manchester Daily Press)

For the Phoenix Park event, around 60,000 people arrived by bus and train; with most Dublin parishes walking to the event to arrive at prearranged scheduled times. The organisation had been extensive to facilitate such a crowd; there were 12,000 volunteer stewards on hand to move people and 600 Gardaí on duty. There were no incidents the entire day, a combination of good planning and good

behaviour. According to the visitor centre display, it was a 'beautiful, beautiful day'. stating.

'We Irish people did all of that – and did it in eight weeks – and did it magnificently. If we can do that, then we as a nation are capable of great things!'



Picture 7.6 The Visitor Centre Display

The pride at this organisation is well deserved; the Dublin based architect firm, Scott Tallon Walker, did such a successful job of design and project co-ordination in the short eight weeks provided, that it was engaged as consultants for subsequent papal visits to other countries. The altar was erected twelve metres above the ground on a stepped and carpeted timber platform which spanned an acre. Having moved the deer off the Fifteen Acres²⁵, the area was divided into blue-roped corrals with wide corridors separating them. Each segment would contain 1,000 people, each having brought their own seating, or purchased the cheap plastic seats available. The crowds were simply herded into one corral, and when it was full the stewards closed it and began to fill the next. This simple method continued until the entire 200 acres were filled. When the crowd was formed the people at the back were about three-quarters of a mile from the stage. About 1,500 toilets and 5.6 kilometres of ringwater mains were provided by Dublin Corporation. Provision was made for 1,500 deaf people, 1,500 blind people, and 3,000 mentally handicap people, 1,268 VIPs, 4,156

²⁵ The name is misleading; it is closer to 200 acres.

clerics and 600 press. These were accommodated at the front of the crowd on long wooden benches.

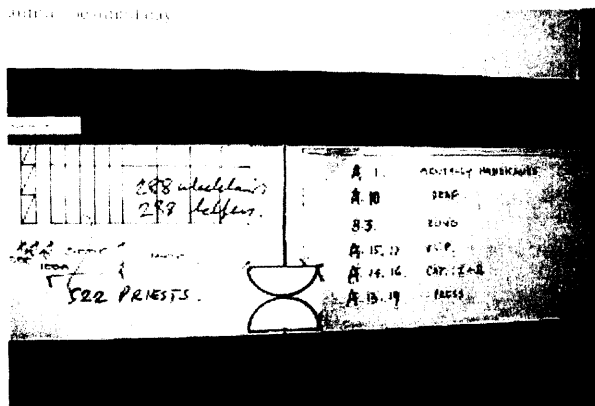

Picture 7.7 Some of the original plans

At 11.00 am the Pope's plane, an Aer Lingus plane called *St. Patrick*, which had been specially designed for the Pope, flew over the Phoenix Park on its way to Dublin airport. The crowd cheered and waved flags, and the Pope is reported to have risen out of his seat in the plane and blessed the assembled crowd (Nolan, 2006). Following the landing at Dublin airport, he was then taken by helicopter to the Park, where he addressed the assembled masses. In his homily, the Pope spoke about materialism and how it leads to the destruction of religious values and the threat to belief by new challenges. He condemned the IRA and their actions, prompted by the killing of Lord Mountbatten, his 15-year-old son grandson and 15-year-old Paul Maxwell in an explosion on his boat in County Sligo a month prior to the visit, cited as the reason the Pope did not travel to Armagh in Northern Ireland, as originally planned. The Pope said, 'Like Saint Patrick, I too have heard the voice of the Irish calling to me. And so I have come to you, to all of you in Ireland' (quoted in Nolan, 2006: 135). He went on to talk about the missionaries Ireland had sent to different countries, including his native Poland, to preach the gospel. He talked about the history of Catholicism in Ireland, tracing its roots through from medieval times to the nineteenth-century mass rocks in fields and forests when Catholics were penalised for practicing their religion. Drawing on the previous large religious event, the Pope said that the huge numbers which filled Phoenix Park at this time were at one with those who had filled the Park during the Eucharistic

Congress in 1932. Following the mass, the Pope mounted what became known as the 'Popemobile' (Picture 7.5), and traveled at walking pace through the corridors between the corrals. Following this circuit, the Pope got back into his helicopter and took off for Dundalk, where he would address another 400,000 people.

It was planned to remove the forty-tonne cross after ten weeks, but an appeal was made to the OPW and the cross remained where it was. The area around it has been developed, with steps up to the top of the mound, and trees planted along the path up to it. The carpark is at the end of this path. On the mound under the cross, on the side of the Fifteen Acres there is a large stone plaque which reads,

'Moladh go deo le Dia [Praise to God forever] John Paul II offered mass at this place in the presence of more than one million people on the 29th September 1979. Be converted every day.'



Picture 7.8 The writing under the cross, looking out onto the area that was filled with people

The social pressure to participate in the Pope's visit was immense, as had been the desired effect of the visit. People experienced great pressure to attend one of the masses, and one of the only ways to avoid this was to work in local hospitals for the day. The Pope's choice of Drogheda as a second stop can be understood as a strongly political act; he was as close to Northern Ireland as possible without crossing into the North. The Northern Irish Catholics travelled down *en masse*, symbolically joining with their Southern counterparts. At this mass, the Pope talked about peace, and the desire the Roman Catholic Church held for the unity of Catholics,

Let no one ever doubt the commitment of the Catholic Church and the Apostolic See of Rome to the pursuit of the unity of Christians. Last November, when I met the members of the Secretariat for promoting Christian Unity, I spoke of the “Intolerable scandal of division between Christians”. I said that the movement towards unity must not stop until it has reached its goal; and I called for the energetic commitment by Catholic Bishops and people to forward this movement.

(www.catholicireland.net)

This continued the theme of ‘oneness’ the Pope continually evoked in Ireland; those at the Pope’s visit were at one with the people who had attended the Eucharistic Congress, the Roman Catholics of Ireland were unified as one and the desire for the breakdown of division between Catholics. This can be understood as a social message that extends beyond the events described by the Pope and into the changing Irish society. It was a warning against the breakdown of a unified society and a cohesive Roman Catholic vision. Essentially, this was a message against modern multi-cultural society and the associated values. It came at a time when Ireland was on the cusp of this change and was a very impressive way of reminding Irish society of the Catholic dogma and values that the political forces wished to remain dominant in Ireland.

The importance of this visit was demonstrated by the rise in vocational applications in that year for the first time since the 1960s, and it dropped again the following year. The patch that the visit put on the problems facing the Roman Catholic Church in Ireland was only temporary; the cracks began appearing soon after the Pope left. The entertainment of the young people in the Galway mass before the Pope’s arrival by the charismatic Bishop Eamon Casey and the ‘singing’ Father Michael Cleary was significantly overshadowed in retrospect following the discovery that the Bishop was the father of a 17 year old boy with an American woman. The woman spoke publically about this, undermining the Bishop’s position completely and leading to him leaving Ireland. Following the death of Father Cleary, an outspoken and popular exponent of traditional Roman Catholic views who had his own show on RTE, it emerged he had conducted an affair with his housekeeper, and had had two children, the first of whom was put up for adoption. Following this, there was an avalanche of allegations and emerging stories surrounding the physical and

sexual abuse of children, the Magdalene laundries and so on. Casey and Cleary are clerical bookends on either side of the Ireland of the 1980s; they embodied the optimism of the faithful in 1979 and they precipitated its final crisis in 1992.

The social cohesion that allowed an event like the Pope's visit to occur in Ireland in the late 1970s has been dissolved through controversies surrounding the Church, the state and through the influx of new values. The visit is very contingent; it could not be replicated in today's society, the time has passed when this would be possible. Ireland is now a (more) multi-cultural society and the coherent Roman Catholic social group has been diluted and dispersed. In the following section, alternative events in the Park are examined as a means of juxtaposing contemporary cultural events in the Park with this significant date.

7. An Other side to the Park

Next to the cross and mound is a car park, which acts as the main car park for people coming to watch the deer, or have a picnic, especially on week days. It is also the site of some of the less salubrious night time activities which occur in the Park. In stark contrast to the site as a place of religious gathering and good will, the car park beside the Pope's cross is used as the meeting point for joy-riders and 'boy-racers', and there is a strong tradition of male prostitution in the Park centred around this car park. During the night, the two main entrances to the Park remain open, which allows the residents access in and out including the American ambassador and his family and the Irish President and her family. In addition, there is a hospital in the Park and Farmleigh House which is often the residence of visiting dignitaries, both of which need twenty four hour access. In the past, there were rangers positioned at each gate who could open and close them when needed, but this has been phased out as numbers have been reduced dramatically and many of the rangers no longer choose to live in the Park. As most of the night time activity occurs in car parks, positioning bollards at their entrance has been proposed which would diminish the ability of the joy-riders to congregate in their chosen spot. Due to the size of the Park however, when the Gardaí arrive the joy-riders have gone. The Gardaí 'clamp down' on the joy-riding by making a large number of arrests, and then leaving it for a few months and do the same again. As the Superintendent of the Park describes,

‘And there’s been a big clamp down on those by the Gardaí over the last two three months. But then they build up again, they actually let them build up again and then they’ll go in and arrest fifteen of them or whatever. We’re actually temporarily closing the Papal Cross car park every Sunday night because that’s the night they actually come in. They come in because the Gardaí are on half numbers on a Sunday, and they know.’

(Superintendent, 21st June, 2005: 292 - 299)

The Phoenix Park has become synonymous with male prostitution in Dublin, and is a well known cruising area for rent boys. The Gardaí, already stretched in their policing of the Park, do not prioritise the arrest and detainment of the ‘rent boys’, especially as by its presence in the Park it means that it is not in residential areas where there has been strong opposition publicly displayed by the residents. In April, 1997 the *Irish Times* ran a story called ‘Drug Abuse leads to sex and violence in the Phoenix Park’. This article examines the link between crime, including male prostitution, muggings and car break-ins, which occur in Phoenix Park as a means of funding drug addiction. This ‘darker’ side of Phoenix Park is not published or praised, but it is as much of a reality for the people who live in Dublin about Phoenix Park as the rest of the social history and events. This is an activity which occurs on the outskirts of society, both literally and figuratively. The double stigma, in Ireland, of prostitution and homosexuality, means that this activity is pushed to a quiet, almost entirely closed off (at night) area of Dublin. As the Irish Times article states, ‘There is a seedy – and dangerous – *other world* in parts of the Phoenix Park at night, where young male prostitutes congregate, and gardaí are becoming increasingly worried about it’ (Ball, 1997; ‘my emphasis).

For homosexual prostitution and joy-riding to occur in Phoenix Park, when it gets dark, positions the Park in a very different social sphere of meaning. This can be understood as reinforcing the hybrid position the Park occupies, as a place of stigmatised activity during the night in contrast to the official roles performed there in the day. If the Park by day represents order (through the construction of the layout and the institutional and governmental presence) then this is usurped by disorder and moral abjection by night. The day/ night transition marks a classic divide; the dichotomy is expressed poetically through the shifting light, and the associated behaviour. The idea of a utopian (modernist) park, the

epitome of the constructed ideal in Phoenix Park, is undone through the ambivalence of the space. The recognition in postmodern social science that there is a need to look at the marginal in order to discern the formation of new subject positions, grasp emergent counterlogics to the prevailing modes of domination in society and give voice to the polyphonic patterns of accommodation and resistance to domination (Smith, 1992) reinforces the need to understand the hybrid identity that constitutes the Park. From a postcolonial reading, it is interesting to appreciate the subaltern discourses that are occurring in the Park, forming different social narratives and understandings of the space than those which are more eminent. The overarching discourse which constitute the official telling of the space, like in the Visitor Centre and the tourist information about the Park, construct a certain identity associated with the Park, but there are always disparate discourses which co-exist alongside. For Bhabha, 'Subalternity represents a form of contestation or challenge to the status quo that does not homogenise or demonise the state in formulating an opposition to it' (2003: 32). In their presence, and through the usurping of the public image of the Park, the illegal behaviour which occurs there contests the dominant discourse of the official Park. In Chapter 9 the perceived changes in the Park for the residents and visitors are discussed, and this issue is developed from this perspective.

8. Music and Football – bastions of Irish modernity?

In 2002, it was decided that the Park would accommodate five large-scale events each year, requiring road closures. This means that the current regulations allow five licenses each year under application. One of these events is the annual motor races, which meant that the other four slots are available. The result is that there is now usually one free concert held in the Park each year and one requiring tickets. Concerts have been going on prior to 2002 however, notably in 1983 when 'U2 and Friends' were billed for the 14th of August. The national radio station Radio 2, which is now 2FM, promoted this 'Day at the Races' and supporting U2 were Simple Minds and Eurythmics among others. The attendance was somewhere between 20,000 and 25,000, the confusion arising over numbers due to a fence being torn down which resulted in more people streaming in. Bono brought his father onto the stage briefly, and the crowd sang

‘Happy Birthday’ for the Edge. The general mood of bonhomie was increased with the announcement that Eamon Coughlan (an Irish athlete) had just won the 5,000-metre race in the World Championships in Helsinki. The strong feelings of celebration embraced ideas of national identity as a collective group of people united through these events, and the concert was an overwhelming success. This collectivity can be usefully contrasted and compared to the Pope’s visit as an example of changing societal values and the importance of certain events. In events like this, new iconic figures were produced and endorsed.

The next concert occurred on the 18th of August 2002, and was the first free concert, taking advantage of the new Park regulations. Attendance was restricted to 100,000 though the Park was open and so many more people enjoyed the music from outside the concert perimeters. There were thirty acts appearing that day, and no real sense of continuity or excitement developed. No alcohol was sold in the grounds, making it an event which attracted mostly pre-teenagers and other young people. The line-up encouraged this age group as well, with Samantha Mumba, Bellefire and Ronan Keating providing the biggest names at the event. Following Ronan Keating’s four-song performance there was a steady flood of people out towards the coaches waiting on Chesterfield Avenue to go back into the city. Despite this, there were a string of commercial concerts attracting bigger names with the promise of a large, spectacular event and the Park has hosted Robbie Williams (2002) who attracted a 135,000 crowd which was a great success. Once again however, the free concerts failed to make such an impact with the 2005 one hosting performances by Charlotte Church, the Saw Doctors and the Camembert Quartet.

The Park has hosted celebrations for the Irish soccer team twice following their involvement in the World Cup. The first, in 1994, provided a welcome home for Jack Charlton’s World Cup team. It was widely agreed that the Phoenix Park reception for the homecoming of the Irish soccer team after the World Cup in 1994 was poor with only 40,000 people attending and the entertaining mainly consisting of a nascent Boyzone dancing around in orange boiler suits. Despite the sunshine, and the initial mood of excitement, the crowd dissipated quickly and the event ended. In 2002, the World Cup team, this time managed by Mick

McCarthy, was being brought again to the Park. Despite protests from supporters across the country, as well as members of the Irish team, over the decision not to stage the homecoming in the streets of the capital, the consensus among the organisers was to choose Phoenix Park, on safety grounds. More than 100,000 people attending this event, and despite the mud, it was a unifying moment and a time of celebration and expectation for the Irish team. Once again the Park was used as a place of congregation to support the representatives of Ireland. These events were facilitated to provide the sense of unity which is required for an idea of a nation, through the building techniques as discussed by Anderson (1983).

The nation building and social unity produced by these events is compelling, but compared to the Pope's visit insignificant in terms of size, scale and social unity. The largest crowd came together for the Irish football team in contemporary times, and the event was perhaps closest to the Pope's visit for those involved. It marked optimism and unity, a feeling that the Irish were participating on an international stage and making an impact, while also celebrating the specific 'Irishness' of the occasion. Unlike the Pope's visit, retrospect does not mar these events; Irish popular music and football continue to develop and improve and represent Ireland in a positive manner on international stages. These events demonstrate the ambition in Ireland to be regarded as a European city of importance, and to participate on the world stage of events. Since the Eucharistic Congress, Ireland has sought to be recognised on these levels, and while the Pope's visit was about insular beliefs and the continuation of an ideal of a nation united under a religion the other events in this chapter are juxtaposed in their outward looking determination and links with other countries, while at the same time celebrating particular aspects of contemporary Irishness.

9. Conclusion – Changes in Function and Identity

The function of Phoenix Park has altered considerably since its beginnings as a Royal deer Park. It has shifted from a peripheral spatial and cultural space to being integral to both Dublin and the Irish nation. The Management Plan may prioritise the conservation of this Park over the role it provides for the visitors, but in the next chapter this will be looked at from the point of view of the

consumers of the Park, the visitors, and the residents. The function is continually evolving, with the development of flats and houses around the outside of the Park, the Park has become a 'back garden' for those who reside near it. The Phoenix Park racecourse, which closed in 1994, was sold in May 2004 to facilitate the building of 170 apartments. These apartments sold for between 350,000 and 500,000 euro, and on the first day of sale more than eighty people queued outside the offices of the estate agents to secure a place. These apartments were among the most expensive to be sold on Dublin's north side in recent years, and the estate agent said that their proximity to Phoenix Park was a huge selling point. This tide of property development around the Park, and the associated change in the function and position of the Park means that it will once again change and adapt to the continual shift in expectation and use.

This chapter looks at the important events which have occurred in Phoenix Park through the years, and their implications for ideas of Irishness and the nation. The relationship between the Park and the state is developed in other chapters, through the different governmental institutions which occupy the Park and their displays of power within it. This relationship is examined historically, and this chapter begins to reconcile ideas of nation and state through the events which have occurred in the Park. This is done also through the positioning of the Park during the various campaigns for independence, and the post-independence policy and cultural trends up to the Park's contemporary events and uses. This chapter presents some sides of a multifaceted story. The focus on specific events and symbols in the Park is indicative of a more complex and intricate culture. Through the use of popular histories and accounts of the Park, this research positions it within the culture of Dublin and Ireland. By using postcolonial theory to understand and attempt to explain certain aspects of the Park's culture, a specific reading of that narrative is required, which was done in an attempt to develop ideas of postcolonialism, Irish identity and their relationship with the space.

Returning to the trinity proposed by Kiberd (1996), this chapter has looked at who has 'invented the Irish' and the different important influences which have figured. The Park has been the site of a number of key events which can be seen

to be part of this process; events which have been linked with the British colonialists, events which have been used as demonstrations of Irishness and what is important for an Irish national identity and events which have consequently proposed ideas of Ireland itself. Kiberd's trinity seems to work well for this discussion of the events in the Park, and also the necessity to understand the local and contingent issues surrounding ideas of national identity. This chapter has sought to demonstrate the constructed nature of ideas of a singular national identity, though it has also suggested that there is something unifying in mass events. For the people present at these events the significance is linked with the coming together and sharing that occurs between people and the linked experiences this produces. This is a demonstration of the tenets of strategic essentialism (Spivak, 1988) which employs the adoption of a flawed ideal of unity to help forward a sense of togetherness. Within this group, there are varied and multiple subjective accounts and individual understandings.

There is a sense of the ambivalence of the double narrative moment between the pedagogic and performative aspects of the nationalist narrative as Bhabha (1991) discusses. The nation is torn between being a historical, fixed essence that exerts a discourse on the people, the objects of the discourse, and the people themselves being part of the construction of this discourse, making themselves subjects in the construction of the nation. The presence of counter-narratives from groups and people who do not belong within the pedagogic unified concept of nation disrupts the constructed ideal. The presence of these counter-narratives has been highlighted through this chapter, and is continued as a theme in Chapter 9. The different understanding of the cross in the ground, the use of the Park by joyriders and male prostitution all point to the proliferation of these counter-narratives which disrupt the idea of a unified understanding of the space and the expressions of identity associated with it.

The similarities between the function of the Park during colonial times and following colonialism are more striking than any prominent differences. This informs ideas of ambivalence that determine the relationship in contemporary times. There is no clear idea of moving beyond the function of the Park as it was; instead there is a continuation of it as a place for demonstrations of different

forms of power and ideology. The manner through which this is achieved and the achievements themselves are very closely related; from the British military parades to the Pope's visit, there is a demonstration of power, a demonstration of allegiance and a clear ideological statement.



Chapter Eight: The Visitor Centre

‘Tradition doesn’t mean preserving ashes, it means keeping the flames alight’.

Jean Jaures, 1910. Original inscription on one of the beams in the Visitor Centre, put there by the architect.

1. Introduction

Drawing from ideas of authenticity in Chapter 6 and Irishness in Chapter 7, this chapter focuses, spatially and conceptually, on the Visitor Centre. This is a space where issues from the entire Park converge, as it conveys the history of the Park to the visitor, marking the spatial and cultural ‘centre’ of the Park. The proximity to the restaurant means that visitors to the Park come to the centre, even if they do not go into the Centre. The Phoenix Park Visitor Centre is a focal point of many of the themes in this thesis. It is one of the important sites of the production of the culture or interpretation of the Park throughout its history, and its contemporary uses. This is the place where the history is presented to the visitor, and the Park is historically and socially situated.

In the rest of the Park there is minimal interpretation, the Heritage Trail provides some brief introductions to various important aspects and selected fragments of history, but it is in the Visitor Centre that the story is told in an organised, structured way. This Visitor Centre provides important information on the Park, such as a series of posters which outline the ‘Important Dates’, ‘Uses of the Park’ and insights into the history of the Park. Through this it highlights the times which are remembered and consequently, the times which are forgotten. In addition, the architecture of the Visitor Centre provides an insightful perspective on the ideas of the liminal in the Park, through the manner in which the building was planned and constructed, as discussed with the architect. This chapter will begin with the architecture of the building, before moving inside and focusing on the content and presentation.

2. The Building

The history of the building has been discussed in Chapter 5, and this section will develop that description by using the interview data and ethnographic inquiry. The Visitor Centre was designed by one of the leading architects in the OPW, who has also designed many other key buildings in the OPW portfolio. The thinking behind the Visitor Centre reflects this skill, and the justification for every aspect of the building has been carefully considered and positioned in relation to the other buildings in the Park and the history of the Park itself.

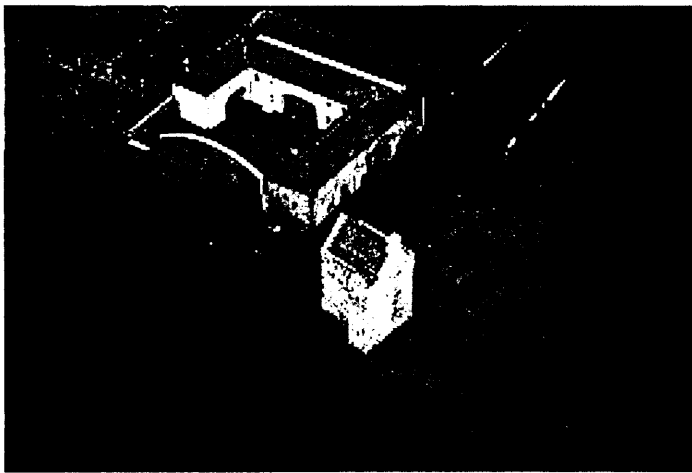

Picture 8.1 Aerial view of the Visitor Centre, Restaurant and Ashtown Castle

The Visitor Centre has two distinct sections, the entrance off the courtyard which is part of an old eighteenth-century building coupled with a slightly newer nineteenth century section, and a new section joined to this. The older piece is stone, while a decision was made by the architect to denote the new section as being built in a different time scale, and so an alternative build material of wood was selected. This was not the only justification, the budget for the Centre was tight and timber provided a cheap way of constructing such a building but the overwhelming reason was the statement such a build material could convey. This building was planned so it didn't 'interrupt the old building' (Architect, 9th May, 2005), constructed with a simple agricultural barn design which meant that the foundations of the old building could be left intact. This simplicity is conveyed in the final building, though this simplicity communicates an aesthetically developed, beautiful space. There is a play between the 'big strong heavy stone walls ... against the light of the timber' (Architect, 9th May, 2005),

coupled with the darkness of the old building with its thick stone walls played against the light of the new one with its glass walls. Where work was done on the old walls, the section where the joining of the old and the new occurred, it was clearly marked through the use of metal beams. There is no confusion over what is new and what is old in this building; the boundaries are clearly marked. In addition, the building is constructed using sustainable materials, made of jute and linseed oil among other things and the timber used is Irish (see Appendix 3 for architectural drawings).

To build the Centre in such a way, the architect had to present and defend its design to important people connected with the Park. There was an undercurrent of disapproval in the reaction to the plans from a contingent who felt the building should be made to look traditional. This was demonstrated in a discussion that occurred between the different factions about the gates which were used around the centre. These were nicknamed ‘Mondrian gates’ by the architect and builders, relating to the artist and the similarity between his work and the gate. There was one of these gates still intact in 2003, but by 2004 it had been removed – the architect did not know by whom. A debate had occurred around whether a ‘traditional’ gate should be used or something new,

‘He wanted a traditional gate; even though the hole in the wall didn’t exist so I’d invented something new, then you make it contemporary unless you have definite information about a historical thing and [if] you can do that then that’s that, but if you don’t have that information then you don’t make it up so there was a big philosophical discussion about what was the right approach. We did win out on it, there were certain viewpoints at the time that it should be that everything copied the existing buildings, and I’ve never favoured that, and I remember using the quote from Jean Jaures, and it was on one of these things [shows metal bar on photo] but they covered it up I noticed recently, and what he said in 1910 was ‘tradition doesn’t mean preserving the ashes, it means keeping the flame alight’. And what I took from that is you’re contemporary or of your own time and that is what you do, you don’t just copy like 16th, 18th, 19th century, but a lot of people still hang onto that thing of copying what’s old but that was the thing about the approach and that’s how it turned out in the end.’
(Architect, 9th May, 2005: 239 - 252)

There was a ‘tremendous arm wrestle’ to get these ideas approved and accepted though philosophically the architect was firm in his convictions. The architect discussed the issues examined in Chapter 6, how the Park is placed in the time

frame of the 1840/1850s, which is viewed by some as its 'traditional peak'. The architect problematised this by saying,

'I've always said the Park is much older than that, how do you pick a line that this is the time? And I think it's a very dangerous one to play. History is a matter of creation, of laying down different layers, you can't just sort of selectively just pick what suits you and I think we had very robust discussions let's put it that way...'

(Architect, 9th May, 2005: 265 - 269)

Of course there were other factors involved in the choice of building and style of construction; to reconstruct the building in a traditional way would have been far more expensive, and so economics allied with the architect. In addition, he had won the ideological and philosophical argument by demonstrating that this wasn't the only time period for the Park, that there had been alternative layouts prior to the work of Ninian Niven and that group of landscape designers, to whom the 1840s layout was a reference to. When presenting this argument, the reply he got was that the previous layouts hadn't been the best layout, and it was there that he won the intellectual discussion. His recourse to ideas of objectivity and rigour meant that his position was more viable and acceptable to the OPW, but also to the people opposing him. The architect was also able to draw on ideas of conservation from the Venice Charter²⁶ which states in Article 9 regarding restoration that,

'The process of restoration is a highly specialized operation. Its aim is to preserve and reveal the aesthetic and historic value of the monument and is based on respect for original material and authentic documents. It must stop at the point where conjecture begins, and in this case moreover any extra work which is indispensable must be distinct from the architectural composition and must bear a contemporary stamp.'

This Charter clearly demonstrates the architect's position. In addition, the architect drew on ideas of façade to reinforce his point.

'I would just say this is what we're doing and if you do it the other way it's just mimicking, it's just Disney Land stuff you're doing. So it was ferocious, he got

²⁶ International Charter for the Conservation and Restoration of Monuments and Sites (Venice Charter 1964)

very annoyed when I mentioned that, and I said it's just theme park that it's mimicking and he got very annoyed.'

(Architect, 9th May, 2005: 296 - 299)

The Visitor Centre occupies a liminal position architecturally; there is a political and cultural statement and achievement in making the space in a non-structural, open way when architecture is synonymous with fixed building structures. The building embodies symbolic movement; there are shifts from stone to metal, heavy to light, past to future. The relationship between spaces and practices of liminality is illustrated in the approaches of Italian architectural group *Stalker* (Smith, 2001). *Stalker* are interested in disused and physically marginal, urban spaces where people appropriate and occupy space beyond architectural practice norms. Within these spaces, *Stalker* believes that architecture can be manifest as events and acts of occupation rather than building form alone. The awareness of ideas of liminality is present in architecture discourse, and the ideas can be found in the Visitor Centre and in the interview with the architect. As a space of resistance, a tenet of liminal space associated with Bhabha (1991), and production of knowledge, the Visitor Centre embodies these themes convincingly.

3. Telling Tales – Presenting the Irish

The Visitor Centre interprets the history of the Park and represents it to the visitor. Through this interpretation and representation a certain history is presented, and choices about what is included and excluded are made. The history is selective, and selected to tell a unified story. The subaltern voices are silenced, and the history privileges certain interpretations of events and narratives. This chapter is concerned with the park this story constructs, the way in which it is constructed and the devices employed to tell this story along the way. As such the Visitor Centre is a pivotal site for this. The history of the Park spills into the present, the centre itself is located beside Ashtown Castle, an imposing stone building that has had a myriad of uses through the Park's history. On the other side of the square enclosure the Visitor Centre is located in, there are seats outside the restaurant, and the side of the building facing the car park is

covered in beautiful wood, with silver lettering in a Celtic style of writing telling you that this is the Restaurant. in Irish and English.

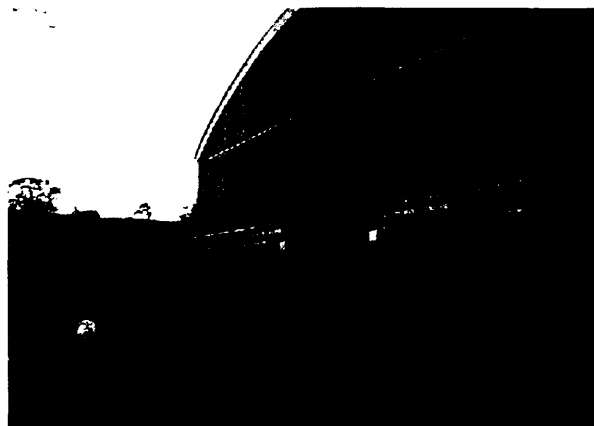

Picture 8.2 The Restaurant

The entrance to the Visitor Centre is more difficult to locate. Beyond the restaurant, there is an old house; and you must walk through the entrance beyond that.



Picture 8.3 The entrance to the Visitor Centre – through the archway, with the new section visible at the back.

Alternatively, you can walk through the restaurant to get to the courtyard. Following the path beyond the tearoom, there is an opening on to a cobble-stoned courtyard, with the tearoom on the left and the interpretive centre on the right of this square of buildings.

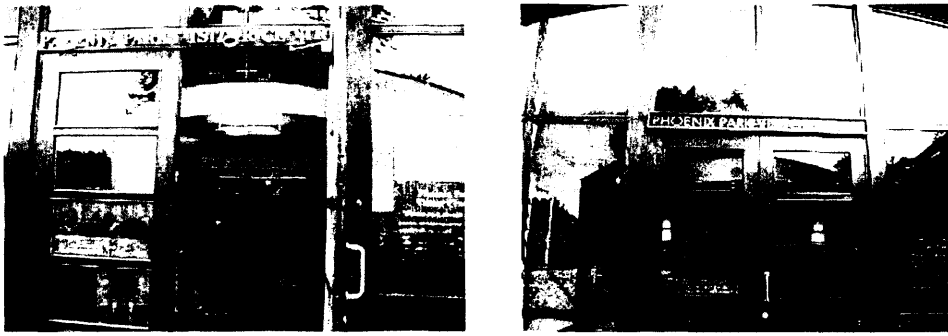

Picture 8.4 The door into the Visitor Centre (2004 and 2006)

4. Into the Centre

Entering the centre, there is an information desk to the right and on weekends a desk to the left selling tickets for the tour of *Áras an Uachtaráin*. On approaching the desk, it is necessary to pay for an entrance ticket. The ticket has the Office of Public Works sign on it, and is written in both English and Irish. This ticket is standard for OPW sites across Ireland, with the name of the site on the top left hand corner and a different colour for each site. There are pictures of other sites of interest around Ireland on the ticket. On the desk are leaflets detailing aspects of the Park – maps and histories of the place, including tourist information for the rest of Ireland. Following purchase of the ticket, the guide directs you to a small room to the right of the desk. There are plastic seats set out closely in rows, and the room has a capacity for about fifty people. The seats are close together and the rows are tightly spaced. The walls are stone and thick, and the two windows have blinds pulled down. There are pictures of the Park around the wall, showing images of nature. The guide dims the lights and, on a large screen at the front, a short film begins.

5. The Film: A portal into the Parks history

The film opens with scenes from Phoenix Park shown while bodhran music plays; pictures of deer and trees, greenery and children playing move across the screen. This continues for about three minutes, until the ‘Story of Phoenix Park’ begins. A male voice with a Dublin accent narrates in English, with pictures of the Park and historical documents and pictures providing the visual. The video is professional looking in its production and sound, and threads of sentiment and

nostalgia run through it with the use of traditional Irish music playing over dramatically filmed scenes of landscape.

The video begins with the pre-history of the Park, starting in 3500BC, when Phoenix Park was a 'sacred land'. Moving onto Viking times the film tells that the largest Viking cemetery in Europe is within the boundaries of what is now the Phoenix Park. Indeed, this site was held as sacred. The site has not simply become a site of national interest, but this interest is rooted in millions of years of history, pre-dating the Park's construction. The timeline jumps forward to the First Duke of Ormond, James Butler, when in 1662 he commissioned the Park as a Royal Deer Park. It records how the Park was larger than present day at that time, and in 1684 the present site was defined, in the area south of the River Liffey. The film states that the Park is larger than all London's parks put together.

The deer, an important part of the Parks past and present, were imported from England. Great expense was taken to find the right sort of deer to be used to populate the Park. However, these deer, the video tells, were 'troublesome' and so a wall around Phoenix Park was built. The nature of the 'troublesome' deer was not detailed, and the wall's purpose was not specified. However, the building of the walls marked the completion of the 'vision of Royal Hunting Park'. This wall meant that the 'public' were excluded from the Park, and the country estate that lay outside the boundaries of Dublin lay also outside the normal lives of the people of Dublin.

It was not until 1745, that Lord Chesterfield opened the gates of the Park, and allowed anyone to enter. In 1779, it remained open on a Sunday to allow hurling to take place. This however, according to the *Freemason Journal* of that year, encouraged 'the lower class of people' to come into the Park. At this time, Chesterfield planted a number of noble elms that lined the roads, but these have now all gone, through storms and elm disease. These elms produced the desired aesthetic, as the Park was meant to be for 'gentlemanly pursuits'. The activities that occurred in the Park were not always such however. The 1798 Rising, which subsequently failed, began with a duel between Wolfe Tone and McNally

which took place in Phoenix Park, leading to the arrest of Fitzgerald and Wolfe Tone. An arms fort was built in the Park, much to the reported despair of Jonathon Swift. The symbol of Phoenix Park as a bastion of good values and gentlemanly pursuits was being eroded.

As the Park grew in importance to the people of Dublin, there were incursions into its grounds to build monuments. In 1817, the Wellington Monument was started, and after the fourteen years it took to complete it, it stood as the tallest monument at the time, now only surpassed by the Washington Monument. The pictures on the side of this monument were cast from cannons used in the battle against Napoleon. The position of the monument was chosen as an area that was not very developed, but as Georgian Dublin expanded there was considerable development in the Park. Buildings began to house important people, with the British governing forces occupying the newly built houses and lodges in the Park. The Ordnance Survey took one of the buildings in 1860, where it remains today. The video shows pictures of colonial ceremony here, which occurred in the Park. The soldiers stand at attention, very important men lead ceremonies, and people jostle to see what is going on. The division in dress between the elegantly attired men and women who wear clean crisp white clothes, or dark hats and long black jackets is juxtaposed to the crowds whose appearance is lost in a blur of grey. The prominent, important, people stand out against this sea of grey, defined and historically clear. The grey people remain faceless and without composition.

The video then moves forward again, this time to contemporary times. The Park became a National Historic Park in 1986, and the primary aim is now conservation. The Park is concerned with the preservation of historic features, the landscaping and maintenance of the gardens and forest areas. Bodhrans beat their distinctive rhythms and the traditional Irish music pipes up, the green of the Park is shown on the screen, with the views sweeping over the expansive site. The emphasis shifts from being interested in historical facts to the presentation of the Park as it is today. The heritage and nature walks are discussed. The use of the roads through the Park are highlighted, it is a busy place with over 30,000 cars going through each day. This does not rest well with the 'green' image of

the Park, and we are told that the Office of Public Works wants to eliminate the through traffic. Mobile Park Rangers are found throughout the Park, and are shown in the film driving around in their blue jeeps, with yellow flashing lights. There has been an increase in sport and recreation in the Park in recent times, with Bohemian football club, horse racing, hurling, polo and cricket, all of which are shown taking place in the Park.

As an end, we are reminded of the 'heritage' of the Park, the oaks at the entrance provide a 'unique heritage', as they were planted by the workers in the 1600s and are now a 'gift of a generation long since past'. In this closing section, the heritage of the Park is brought back to the Irish workers, who were used to build the high wall around the Park. The symbolism of the oaks is claimed as something which can be linearly traced to contemporary Irish people, and the closing image is of a small child with an old oak tree, symbolising the union of past and present that seems to be the theme of the film.

6. On Displays

Leaving the video and walking through the reception area, there is a right turn, under an arch, into the main display area: and the new part of the building. Before going into this main area, there is another room with different exhibitions on display in it.



Picture 8.5 Exhibition Space in Phoenix Park Visitor Centre

This exhibition changes, but at the time of the first visit it housed 'Phoenix Nights', a collection of paintings by Debra Wenlock showing scenes from the Irish Grand Prix which went through the Park in the 1900s, the next collection (in the picture) was a selection of art work relating to the nature and fauna and flora of the Park which was for sale. The work in this room is selected based on its connections with the Park, with previous work including landscape paintings, black and white photographs and abstract works of the Park. The room is dark and cold, with artificial lighting along the edges and with one central light, the walls are stone and it is beautifully restored. It provides a space which feels hidden and secluded, unlike the newer part of the building.

7. Reception Area

Moving out of this room, and back into the reception area, various posters are on the wall. The largest and most prominent is a timeline of the 'Significant Park Dates'. Beginning in 1177 and ending in 1925, this highlights the events that are shown through the main displays.

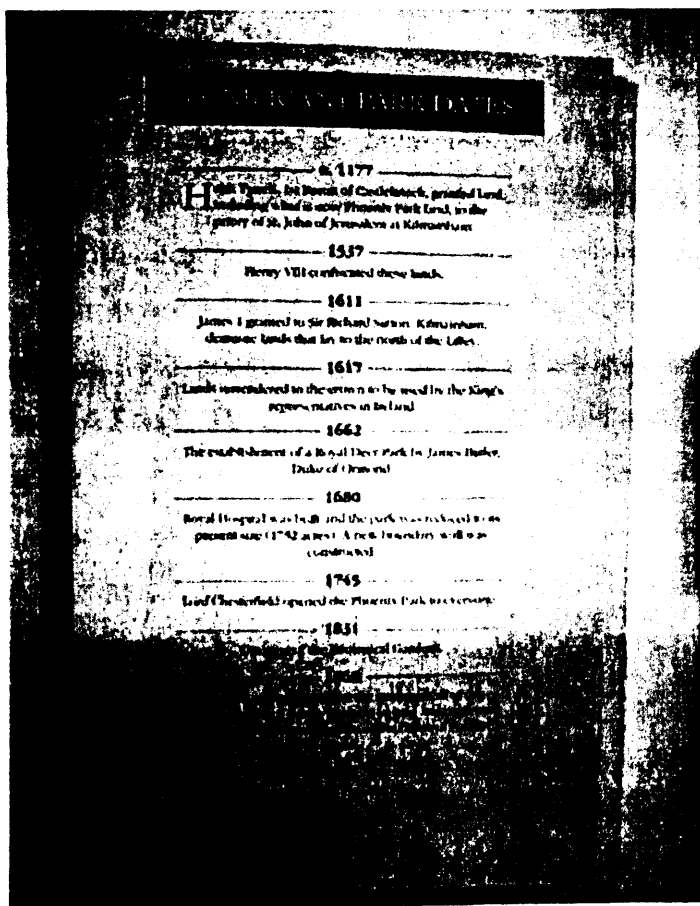

Picture 8.7 Significant Dates Poster

These dates are significant in what they leave out as much as what is included: there is no mention of the Eucharistic Congress or the Pope's Visit. Instead the time line ends in 1925, with the Phoenix Park Act. This may be because there are displays in the main section which deal with these events, and so this chart provides a background to the displays that located within the main section of the Visitor Centre. The choice of dates is otherwise quite strange, and appears to be almost arbitrary.

8. 'The Park through the Ages' – Downstairs

Through this reception area, there is an arch which leads into the main display area. Over this arch it states 'The Park through the Ages'. Directly in front of you as you walk into this area, there is a large three-dimensional display showing a man dressed in seventeenth century attire, with a red coat, embroidered around the buttonholes and collars, and a hat with a large feather in it. On his outstretched arm, pointing to a display that has various animals in it, perches a hawk. The man has long flowing hair, and a moustache that twirls at the end. He is a vision of splendour, and can be found on the official map of the Park (see Appendix 2) and on various other documents relating to the Park. He is symbolic of the Parks history, and as he points over the small section of it represented in the rest of the display, he controls and dominates the scene. The painted backdrop behind him shows woodland, with a twisting path and flowing stream. The animals surround him, with squirrels, foxes, deer and hare on the small hill behind him. His position overlooks this Park picture though he also points out to the real Park. The trees on the screen meld into the Parks actual trees, continuing the scene and the area he overlooks into the 'real' Park.

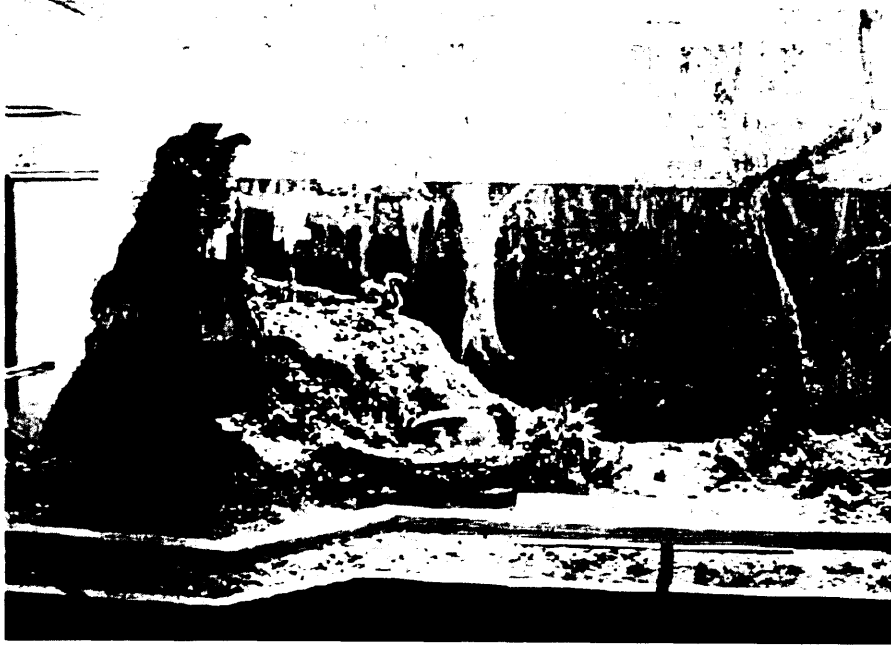

Picture 8.8 The display melds real and imagined

This was very important for the architect, who describes that when the displays were initially installed there were ceiling high pictures of the Park, undermining the work he had done to make the centre feel open and light. He engaged in a ‘battle’ with the designers and the compromise reached was the shortening of the picture displays. However, there are still areas in the displays where the ‘real’ Park is obscured by displays relating to it. This interaction between the ‘real’ and the ‘imagined’ plays on the idea of liminality, and demonstrates the negotiation within the space. Resistance to the ideas held by those designing the interior is demonstrated by the architect, and this ranged from the positioning of the displays to their content. Initially the designs were being carried out by a company who had links with the OPW, and as this quote demonstrates, there were various antagonistic points in the construct of the displays:

Architect: It was a company who did them but I think, I don’t know if they’re still in operation now. But the chap who was involved with it has retired who had different ideas and that. What I found in that there was very little thought process that went into it with that chap he originally had been in forestry and then through some quirk he ...transferred to OPW he came with them, and he had this view that that’s what he should exhibit. And I remember at the time I said like what about the big obelisk [the Wellington monument], these are features as well and he didn’t want to address any of those, so we got some of those put in and we actually got models made of some of the different heights and we had some influence. But all he had before was like that little tunnel thing where you go through with all the different noises [in the Kid’s Corner], and there were a few other things, like the whale?

KM: And the elephant bird?

A: Yea, that stuff, which was really his background in wildlife and forestry but I think he never went to read about any history in the Phoenix Park at all, it was only when we said things to him, and he grumpily agreed to them. Because this arm-wrestle had gone on with [the Chief Superintendent; about the architectural design of the Visitor Centre] and then when we saw what was going on in there [in the Visitor Centre], like they were putting stuff up that was in controversy of the fire regulations and that and I said look you can't do that, and they would say aw no now you keep your nose out of this we're doing it now. And I just said, like one of the stuff they were putting in was a fire hazard and I just said look I wrote a note down saying this is a fire hazard it has to be rectified and they all got terrified internally here [in the OPW]. But it wasn't a mean thing to do, because I thought about it before I did it, it was the easy thing to do I suppose but if it they knew what they were doing they shouldn't have done it that way. And so then we were brought in to do an over view and try and co-ordinate it, but at that stage it was sort of like a *compromise between two groups*.

KM: That is what it feels like, with the two sections, the nature bit and the history bit...

A: Well he was left on the basis of well let him do the nature bit and we'll do the other bits. That's what happened. A compromise I suppose. It was a pity I thought, a pity. But I found it *didn't have that intellectual quality of actually analysis what was happening*. Down in Kerry, when we were dealing with the Blaskets we worked with Pat Cooke [...] but Pat has much *more rigour* about him, and *clarity and appeasing what we knew*, and that was a much better way of working this other chap was all emotional, he used to say to me 'my reaction to the park and I sat there one evening when the sun went down and I felt this...' I said to him that's all very well, but there has to be more than that, we're not all smoking joints and stuff, I said we've all done that, but *this is something that we have to take seriously*. And he said, what did he say 'you architects you're just into the empirical and the measurable, where's the emotion, where's the soul?' So I said, good buildings have soul and good things you know don't lecture me about that but you have to have a rigour about that, it's like good writers don't achieve something just by scribbling, so there was that sort of infantile thing about it. At the end we got sort of some rigour into and people said [to the original designer] how did you come onto that, [and he said] 'oh I just liked that', and you could see people getting a bit nervous about that, and you could see them thinking, 'what's going to happen when they open it'.

(Architect, 9th May, 2005: 362 - 410)

This long quote summarises beautifully the tensions within the design of the Centre and the tensions expressed within it. The two 'sections' of the Centre, marked by the old building and the new building project different ideas of the Park; the upstairs section in the old building, which you reach through the new, has displays relating the nature, and strange discussions on extinction and preservation. There is a Kid's Corner, which is a tunnel with noises and models

of animals' habitats. However, there is not a simple dichotomy expressed by these two positions: the architect does want the Centre to have 'soul', he just wants the history that is presented to be 'rigorous' and critically appraised. This awareness of the importance of the history that is presented underlines his approach – he does not want the present to recreate something that was not there, as demonstrated with the problems over the gate. There is also an awareness of the special history of the Park and the way this has to be dealt with in the Park.

This liminal site, the coming together of divergent ways of thinking, creates a space of resistance and counter-resistance. The authority of rational associated with scientific endeavour or historical objectivism is undermined by the necessity to recognise the emotive. The Park is an emotional, lived, experienced space, with various historical, social and personal importances (Soja, 1996) and to try and capture this in a contained space may be impossible. The necessity to acknowledge and account for the various ways people interact and understand the space, remember and reconstruct it proves a very difficult task in the Centre, and the antagonism as described in the above quote is felt through the displays which try and reduce the Park to composite factors, whereas it is greater than the sum of its parts. This idea of 'lived space' (Soja, 1996) and the desire to move spatial research beyond dichotomies, which is achieved in some way in the centre, as through the antagonisms and debates a new space of meaning is produced, warily at least combining ideas of the rational and the emotive, the material and the mental and producing a synthesis of the two, as contained within the space. The antagonism and ambivalence found within this small space works to construct a new area of meaning around and for the Park.

9. Observing the Displays

Around the main entrance display of the pointing man is a wooden bar; the observer must remain as an observer, and must not interact with the display in any way other than the visual. On the right hand side of this bar, though still central, there are two clay figures. One is a lady, and the other a small girl. They are holding hands and looking at the two deer that complete the scene.



Picture 8.9 Clay figures 'observing' the displays

These people demonstrate what we, the visitors, are to do. While we can respectfully look at the displays, we do not go beyond the bar. Contrasting the attire of the woman and child with the man leads us to surmise that they are more 'contemporary' and are 'more like us', their clothes, though clay and hard, are clothes like 'we' wear. They are not historic figures, but represent the contemporary aspect of the display, which is that of spectator. They are disengaged from the scene, present, but barred from participation. Next to this scene, there is a scale three-dimensional model of Knockmaree Cist, a rock chamber or burial cist.

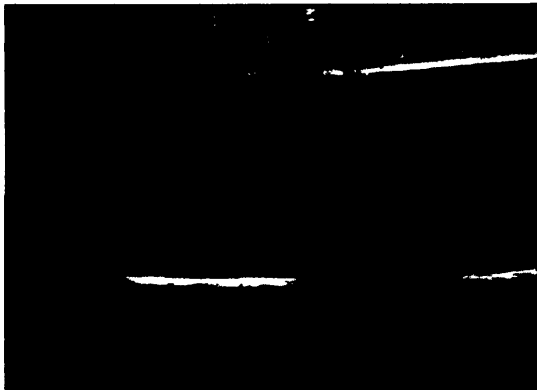

Picture 8.10 Reproduction of Knockmaree Cist, in the Visitor Centre

This was discovered by workmen in 1838, and is the burial place of two or three leaders of the farming communities that date back to Neolithic times. The two male skeletons found in it have been dated to 3,000 – 3,500 BC, which is 'older than the people of the Boyne Valley Passage Graves'. Around this there is information about the Park during these times. Reinforcing what was stressed in the video, the Park is cast as an area of great importance and the uses which the

land was put to during this time is discussed. Moving beyond this scale model, the displays move onto the Early Bronze Age in the Park, showing pictures of men working with pots and tools. There is then a section on the Vikings in Ireland, and a specific focus on 'The Viking Women'. The information in this section is general and related only vaguely to Phoenix Park through the positioning of these groups on the land which now constitutes the Park.

The interpretive centre building is wooden and glass, with long broad windows overlooking the Park. This means that everywhere in the Centre a view of the Park is possible, stretching out over green grass and tall trees. This promotes a sense of being in the Park during the walk around the centre. However, as discussed above, there are small areas of the centre that are exempt from this feeling, and moving to the right of the main displays of the hawk and man and burial cist on the ground floor, the focus is on the 'Military Significance of the Park'. Immediately to the right is an old canon, dominating the floor area, and to the left of this there is a display board and the chair the Pope sat on during his visit.



Picture 8.11 Pope's Chair, Cannon and '40 Elms'

This collection of relics are there without interpretation, the sign on the Pope's chair tells people that it is 'The Pope's Chair', and not to sit on it, and the wooden objects in the display case have no sign. Liam O'Neill is the artist

responsible for this piece, which is called '40 Elms', a reference to the trees that had to be felled because of Dutch elm disease in the Park. The pieces are made with the wood of those trees. Liam has a strong relationship with the Park: in 1998 the Park staged his first outdoor exhibition. First discussed in 1991, this exhibition was commissioned by the Chief Superintendent to use the wood culled from the Park because of old age or disease. The pieces demonstrated in the Visitor Centre were an extension of this work.

There is a picture of troop movements behind the wooden cabinet, but the main part of this display is obscured by cabinet with the wooden sculptures in it. To the left of this, the wall is covered in the display on the 'Military Significance of the Park' and a section on 'Two Boys in the Park', which has accounts from Wolfe Tone and Winston Churchill. The section on 'Military Significance' has a picture of an Eighteenth Century soldier, standing ready to fire. The section includes information on Troop Movements, Military Reviews, The Salute Battery and The Magazine Fort. The Salute Battery used to occupy the place of the Wellington Monument, and consisted of a large concrete emplacement on which were mounted twelve pieces of canon. These were known as the 'Great Guns in the Park' and were used for firing salvos on days of 'jubilation, such as coronations, birthdays of Royalty and victories in battles'. The canons on the Magazine Fort were heralded as a 'constant presence overlooking the city of Dublin'.

The second piece in this section includes quotes from Theobald Wolfe Tone and Winston Churchill about their experiences in the Park, titled Two Boys in the Park. Theobald Wolfe Tone was a lawyer in Dublin, who was a co-founder of *The Society for the United Irishmen* and in 1792, became the Secretary of the Catholic Association. Wolfe Tone was also instrumental in the 1798 Rising for Irish Independence. This was quelled and Wolfe Tone was arrested and charged with Treason. In 1791 he published his influential *An Argument on behalf of the Catholics of Ireland* in which he poignantly asked 'What answer could we make to the Catholics of Ireland, if they were to rise, and with one voice, demand their rights as citizens, and as men?' (Wolfe Tone, 1791). Following this, he called for the rejection of the 'foreign government'. However, the quote that is

displayed in the Visitor Centre focuses on the 'splendid appearance of the troops' (the military review in Phoenix Park), and the desire which this installed in a young Wolfe Tone to become a soldier. Ironically perhaps, it was the Army which inspired him to be a soldier who denied him a military execution leading to his attempted suicide and subsequent death as a result of his injuries. The second 'boy in the Park' is Winston Churchill. Churchill lived in the 'Little Lodge' which was a 'stones through from the Viceregal' (quoting the display), a home which was occupied by Churchill's grandfather, the Viceroy. In fact, Churchill credits a speech his grandfather made in 1878 following the unveiling the Lord Gough statue as his earliest coherent memory. This memory includes 'a great black crowd, scarlet soldiers on horseback...' here the colonial power is in Technicolor, while the Irish crowds fade into nameless background black. The construction of the Irish as the 'other' of Said can also be heard echoing through this statement, and is remnant of the pictures used in the video that construct the Irish crowd similarly, as a grey mass of faceless people. Folklore posits that Churchill haunts Áras an Uachtaráin, as it was meant to be his favourite building in the Park.

The hybrid identity that is expressed through the use of these figures draws upon ideas from coloniser and colonised to construct an idea about the Park, that is both grand and intimidatory. While the Wolfe Tone quote only emphasises the job that the British military fulfilled, within the context of the military review, if the visitor is aware of Irish history they will understand the wider ramifications of this, coupled with his desire to be a soldier. This disjunction between presented and known history creates a space of resistance where historical understanding and presumptions can be reconceptualised and challenged through these processes. The idea of Irish nationalism is questioned by the subjugation of one of the leading nationalist leaders (Wolfe Tone) to admiring spectator of British military presence, and the idea of total colonial dominance is questioned by the reduction of their military unit to an aesthetically pleasing sight.

10. Upstairs

The stairwells are on either side of the room, though upstairs is a balcony and so is not completely cut off from downstairs, there is an overlap of layers and light

and noise streams from one level to the other. The balcony has a wooden floor, but the section under the handrail is glass, though with red warning markings, which allows the light from the main windows to flood in.



Picture 8.12 The architecture is intended to blur inside and outside

Going up the right staircase, which is bare and white, there is a main section immediately in front at the top, and a second section to the right. This second section is over the reception and is not made of glass and wood like the rest of upstairs. Instead this is made of old grey brick, and marks the boundary of the original section of this building. On the wall beside the archway there is a rustic coloured tapestry, showing deer and land that stretches the length of the building. Above the entrance the section is named 'Nature and the Park'. This is described as the 'Children's Section', and the displays are aimed at the younger audience. The focus is educational, and there are sections on the 'biosphere' showing a picture of cartoon children staring up at a photograph of the earth which is suspended above their heads. There are connected sections of 'The Flower Display' and 'The Tree Display', which have bright pictures and short descriptions of what can be found in the Park. A large dinosaur gratuitously adorns the flower display section. On the opposite wall, and the most striking aspect of this room, is a black wooden section of 'Extinct Irish Species'. This lists, chronologically ordered on when they became extinct, animals which can no longer be found in Ireland. Starting 34,000 years ago with the Spotted Hyena

it works up to 1786 with the extinction of the Wolf. At the bottom of this it provocatively asks 'Next species to become extinct?'

Going out onto the balcony section again, the light increases and the view of the Park presents itself once again. A large, interactive model of the Park under a glass dome supplements the green of the real Park. This vast model shows the Park, its roads, trees, rivers and all its buildings, labelled with lights that go on when you press the correspondingly named button on the side.

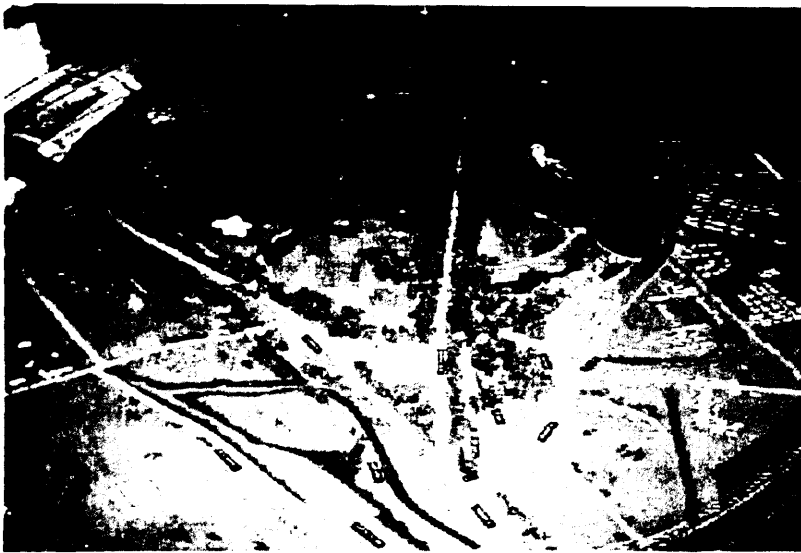

Picture 8.13 Model of the Park

This takes up most of this section, with little space to move around it and look at the different displays. To the left of the model, there is a clear area where the view of the Park is all encompassing. To the right of this model there is a collage of images and newspaper reports relating to the Park, from past times to contemporary photographs.

This section is a collage of pictures and reports of the Park, but it is also a collage of knowledge on the Park, a collage of ideas and thinking which is presented to represent the Park. Historical information is presented beside contemporary events and pictures of the Park, and news on a 'Bomb in the Park' is shown beside a picture of the 1882 Cricket Firsts, and pictures of coal-mining in the Park during World War II are shown beside a picture of school children and a teacher. The pictures and news reports shown are a curious mix of trivia and

incidents of importance. A report on the rat infestation of the Polo Pavilion is positioned unceremoniously beside a report on an execution of a soldier convicted of robbery. Meetings between T. Davis and J.B. Dillon, planning the foundation of 'The Nation', a newspaper which 'set Ireland on a course of romantic nationalism' is shown beside a sign for the first meeting of The Socialist Party of Ireland which took place in 1917. A sign for the 'Motor Car Races' has an Irish written version of 'Phoenix Park', written as 'Páirc an Fionn-Uisce', with Phoenix Park in brackets underneath, and the rest of the sign in English. This collage, like a collage invariably will, presents pictures that obscure parts of the others, some gaining prominence and others receding into the background. In the same way, the knowledge that is presented in this collage obscures some voices, and privileges others: it draws some events into the fore and allows others to fade away.

To the left of this, behind the model, there is a section on 'Significant Buildings'; this list includes Áras an Uachtaráin, Ashtown Castle, the Magazine Fort, Saint Mary's Hospital, the Ordnance Survey Office and the Garda Headquarters. A brief description of the function of each building is present, as is a photograph. This section does, in a sense, the same as the collage, though through a different process. The privileging of certain buildings over others, and the exclusion of others, makes a clear statement about what is meant to be important in the Park, and therefore what is worthy of mention. Beside this, a section on 'The Park Landscape' provides a brief discussion on trees in the park and the zoological gardens. The display on the Pope's Visit, as discussed in Chapter 7, is on the right of the upstairs section.

11. Conclusion - Leaving the Centre

This chapter has focused on the themes that are found in the Visitor Centre and how these can be linked with previous chapters. It began by looking at the architecture of this building, before moving inside and examining the content of the displays and the discussions around their content. For the Architect, the conflict over the architecture of the building and the displays within took on deep philosophical meaning, reverting to debates of rationality and emotion and the interplay between the two and this chapter has proposed that despite the conflict

and antagonism, there has been a position reached that does present the two positions. By having them both within the same building, there is a new site of meaning found, and through the debates and justifications for his requests the Architect's position has been made clearer for him.

This chapter has woven ideas of authenticity, liminality, production of knowledge and Irishness through the discussion of the displays. The discussion at the beginning of the chapter about the Mondrian gates, exemplifying the relationship between old and new as found in the building, brings in ideas of authenticity and how it should be used to replicate or construct contemporary spaces. The video is used to show how the production of knowledge is presented, as is the discussion of the various displays. Like the collage, the whole centre is able to emphasise certain aspects of the past, and obscure others, and the foci it adopts is of interest in this chapter as a site of production of social understanding in the Park. The 'arm wrestle' between the architect and the man in charge of the displays returns again to the debates about subjectivity and objectivity, and in the end a compromise is reached. This is what this building represents: the coming together of two separate things and the result is a space that is interesting, beautiful and, most important, at times provocative.



Chapter 9 Consumers

'I like to think of landscape not as a fixed place but as a path that is unwinding before my eyes, under my feet.'

(Ehrlich, 1991)

1. Introduction

In the previous empirical Chapters 5, 6, 7 and 8 there has been a preoccupation with spatial aspects of the Park as liminal, and the way in which it is represented in the historical events and occurrences. The liminal state is characterized by ambiguity, openness, and indeterminacy. Liminality is a period of transition, during which normal limits to thought, self-understanding, and behavior are relaxed, opening the way to something new. The Visitor Centre is used to suggest the position that cultural representations of the Park occupy through recourse to the architecture and the displays, and the Park itself is positioned as a place 'betwixt and between' the city and the country, the past and the present and nature and society. The different ideas of Irishness are discussed using important events in the Park in Chapter 7. Ideas of authenticity are discussed in Chapter 6, relating to the way the past is displayed in the Park in contemporary times. This chapter begins by summarising the main reasons why people visit the Park and the things that the residents consider the most important and special memories since they lived there²⁷ and as such there are overlaps in focus between the previous chapters though approaching the areas from an alternative position. This discussion is informed by the interviews conducted with residents and visitors, and questionnaires distributed to the residents.

Through dealing with the accounts of the 'consumers' of the Park's culture, the residents and visitors, this chapter continues to look at the idea of liminality, as found in van Gennep's (1960) formulations on rites of passage, and continued in

²⁷ The average time of residence from the participants is 38.66 years.

Turner's notion of the liminal in which the notion of social relationships and social transitions is central through to postcolonial ideas on the concept. Van Gennep characterised three distinct stages in rites of passage – separation, segregation and integration, and it will be part of this chapter to see if the Park can be perceived as undergoing a 'rite of passage' from colonialism to postcolonialism and how this may hold ramifications for the way in which the space is managed and controlled, and how the various mechanisms and institutions to achieve this are performed (see Chapter 3). This chapter looks at this idea of transition and understanding of the Park, and the ways the people within the space understand it and its position in their lives. This links with Shields (1991) work describing the liminal space of a Brighton beach as 'liberation from the regimes of normative practices and performance codes of mundane life' (1991: 83). Liminal phases are associated with acts of transgression, and as Hetherington (1998) notes this is also an act of reordering and social integration, rather than simply some unfettered, counter-hegemonic form of resistance. The temporal liminality that is associated with these processes is something found in Van Gennep and Turner, through their ideas of linear progression through events, and this will be developed by including ideas of liminality in relation to the transition from colonial to postcolonial eras, by recognising that this is far from linear in its cultural development. As Bhabha (2005) states,

'Postcolonialism doesn't mean after colonialism, simply. The post is just there in a way as a marker. And it's a marker that points in two directions. It says that there is a moment where a certain form of dominant hegemonic colonialism has passed but its effects continue. And that there are societies now that are coming to terms with their own social forms, their own cultural forms and in that sense they are in a process of transformation. I think the best sense of the postcolonial is to acknowledge transformation. And transition.'

(Bhabha, 2002)

For postcolonialism, then, the temporal is important as a way of marking difference, of acknowledging the transformation and transition between colonial and postcolonial society. Following this, a theme of this chapter is the idea of transition as expressed through the different views of the residents and visitors, groups who have witnessed transformations in the Park. The Park has undergone considerable cultural changes over the course of the last one hundred years, as

described in previous analysis chapters. The accounts from the residents, many of whom have grown up in the Park and worked there in some capacity, offer the most insightful perspectives from which to comment on these changes, allowing the Park to be understood through their dwelling perspective. Turner explains how the process of separation includes symbolic behaviour – especially symbols of reversal or inversion of things, relationships and secular processes - represents the detachment of the ritual subjects from their previous social statuses. During the intervening phase of transition, the ‘margin’ or limen, the ritual subjects pass through a period and an area of ambiguity, a sort of social limbo which has few of the attributes of either the preceding or subsequent profane social statuses or cultural states. This state, a transitory, in-between state, allows for a gradual transition into the next stage. This chapter suggests that this ‘progression’ should not be regarded simply in a linear manner, and can be better understood using the image of the rhizome, which demonstrates the complexity of this transition through its growth directions.

Phoenix Park has undergone several important changes since its colonial past, though it is argued in this chapter that it is still in the gradual, in-between state before it enters an unknown next stage. The rituals of the ‘old regime’ have slowly faded away, not in a momentous ritual of de-colonialism but in gradual stages that have gently shifted the management style, function, use, look and ideology in the Park. These shifts will be portrayed through the eyes of the visitors and residents, which will highlight the important visible aspects. There is also seasonal shift in the function and aesthetic of the Park, and this ‘natural time’ underpins the ‘social’ and ‘cultural’ times which exist on another level continually present in the interaction between social life and the Park, a constructed natural space.

This chapter is concerned with the historical and cultural narratives around the shifts in management style, function, use, look and ideology of the Park as understood by the people who live there, visit there and have memories of the different events which occurred in the Park. The residents of Phoenix Park have a unique viewpoint; many of them have lived there for over twenty-five years. They have a close-up view of the Park and the changes which have occurred. In

contrast to this, the visitors to the Park leave at the end of their walk, drive or meal. The narratives and stories about the Park presented by the residents and the visitors are split into elegant praises of its quietness, natural beauty, the Pope's visit and sad reflections on the atrocities which have happened in the Park, and the historical legacies signified by certain institutions and monuments. This chapter looks at these narratives, with an awareness of the themes of transition, time and space.

2. The Popular Park

This section presents the main reasons people visit Phoenix Park, and the things that the visitors and residents consider the most important in the Park's history and their personal histories with the space. Through doing this, it positions the Park in the public consciousness, showing the associations with the place and important occasions that are remembered.

The Papal Visit of 1979 reverberates in the memories of most of the residents and visitors. The size, scale and national importance of this event has already been discussed in Chapter 7, and it continues to be the event with the most impact for those who were resident in Phoenix Park or living in Dublin at the time. The organisation and wider social context have been discussed previously, and this section will continue the themes but approach them from another perspective – that of the residents and visitors to the Park. This separation of the two sections, the 'producers' and 'consumers' of the Park's culture, is artificial but allows a interrogation of the ideas of nation and local culture. Through approaching it from different empirical positions it offers a triangulation of sorts, helping to construct the same event through different accounts and perspectives. The manner in which the event is understood and constructed by the official Park accounts can be read in conjunction with these accounts to examine any difference of understanding.

For some residents the Papal visit meant a large family gathering, as their home became the place where people stayed before the big event.

‘I had forty people staying the night as the Park was closed the day before. Staying at my home were my brothers and sisters, their families and friends. It was a grand day.’

(Resident 5, questionnaire)

The day itself was seen as demonstrating a wider good, a sense of what could be achieved and what was possible. At a time when Ireland was looking for a way to demonstrate its place in modernity this day allowed a global demonstration that it could achieve something important. There are obvious contradictions between modernity and religion, but the significance of the Pope being in Ireland demonstrated that Ireland was important enough a presence on the world stage to merit a visit on the tour. The complex political and social positioning and ramifications of this event have been discussed in Chapter 7, but this section brings it back to the people in the Park, moving from a macro examination to a very micro one that focuses on individual experiences and memories of the event. The most common responses to questions relating to the Pope’s visit evoked a sense of pride and importance, and these feelings are best summarised by one of the Rangers who was working in the Park at the time.

‘Ah! The most prominent event was the late Holy Father’s visit to the Park in ’79. I have to say it was an extraordinary three days here. If one believes in a greater being, then those three days were the proof. They many examples of goodwill, tolerance, the total lack of crime was extraordinary. I was a Park Ranger for 40 odd years and I never seen the like of it, before or after.’

(Resident 1, questionnaire)

For those who had participated in constructing and organising the day, the pride associated with this act was immense and it formed part of the memory associated with the event. The following extract focuses on this, while once again returning to the spectacle and significance of the occasion.

‘There were a million and a quarter people, in that part where the cross is now. I was up there that time. I worked on the construction, the firm I worked for, we had a part of building part of the platform and all eh surrounding and all before the Pope came. He landed in the helicopter, it was a great reception. It was a special day for the people. Packed it was, I’ve never seen anything like it. It was a beautiful day and when he came oh you could hear the roar of a million people’

(Visitor 8, Chesterfield Avenue, 5th January, 2006)

The act of all the people coming together in such a cohesive, orderly manner has been a lasting memory for all those who attended, and for some this extends

beyond the religious significance of the event. The position of the Catholic Church at the time in Ireland was strong, but its subsequent demise based on continued allegations and revelations around child abuse, sexual activity and financial improprieties, as discussed in Chapter 7, have tainted the memories of some towards specific aspects of the day.

·KM: That must have been a good day?

·Well I suppose it was I suppose it was. Em, again, I'm not a totally religious person and I wasn't just that impressed. Especially when two of the priests on the alter have had kids and knocked off money, ya know it doesn't impress you. But yea, it was an amazing day in that a million people all came with the one thing in mind. And eh they were up-lifted I presume you know.'

(Visitor 14, Papal Cross, 3rd March, 2006)

The day itself seems to have transcended the associated religious dogma in the above account and in many others, and it begins to take on meaning beyond the religious in the memories of some of those assembled. The reason for attending was to see the Pope and be in his presence but the memories associated with this event are more focused on the other people attending, the associated memories of family and gathering or the input of personal actors into making such a great event occur. This makes it an event that can be understood by a wider range of people, and a memory which communicates things about the people in attendance, almost a third of Ireland's population, and less about the reason for which they did this. This marks the cohesive society that it occurred in; the group of people who came together were brought together for a certain reason, but the meaning associated with the day for them went beyond this event, and in their memory it is the cohesion and unified group that prevails.

This is part of the discussion of Irishness that constitutes Chapter 7, and is why the Pope's visit is one of the epoch defining events discussed. This relates to the theme of this section, modernity and the positioning of Ireland and the Park within a local understanding, which stands in juxtaposition to the following section where the Park is seen as a magical, natural place, with local social encounters and events. This reinforces the idea that the Park embodies contradictions, ambivalence and ambiguity about its meaning and the way people relate to its history and contemporary significance.

3. A Personal, Magical Place

The personal memories associated with the Park are another important composite of the public consciousness surrounding the Park. People remember being brought to the Park as children, to visit the zoo, have a picnic or play football (Visitor 8 and 3), and these special childhood memories define the space for them now, pulling them back to this significant place to walk, exercise and relax. For some residents, their personal memories are linked to their children and family. The space takes on a new level of meaning for those who have raised a family within the Park, especially when it extends back for generations,

'I came into the Park as a young bride; my late husband was born in the Park so my memories are all about his family and of course my own children who all grew up there, no better place to rear children. I love living where I am, getting up everyday and looking out my window and seeing grass, trees and sometimes the deer, all this is very special to me.'

(Resident 6, questionnaire)

In some accounts the Park is described as a 'magical place', which means for these participants a place outside of the everyday and mundane. These accounts are primarily concerned with a sense the 'magic' which the Park provides through events which have occurred within its walls. This sense of magic is interesting in its juxtaposition to ideas of modernity that is otherwise prevalent in the events that have shaped the Park. It imposes another level of understanding of the Park, one that falls outside the rational and empirical. One of the residents and Rangers describes the 'magic' of the Park through recourse to his marriage,

'I am one of the few people who live and work in a magical place. If you ever decide to write a romantic novel, myself and my wife's love affair started in the Park in 1970 and it's still going strong. No wonder I think it's a magical place'

(Resident 3, questionnaire)

There is another 'magical' aspect to the Park as described by the visitors and residents, the feelings of escape from the everyday that people associate with the space. It is seen as a refuge, an oasis away from the strains and stresses of modern Dublin and modern life. For one visitor, this stems from his childhood when he viewed the Park in that manner, and imagined a better life for himself in the Park.

‘Well, I used to live in Ballyfermot [area in north Dublin], and we were very poor. And I used to go into a place called Moore St and I knew the woman there in the stalls and they used to give me the empty orange boxes and I would take these orange boxes home and chop them up for firewood and sell them for a penny a bundle in those days. And so I used to go down around Chapelizod and some fond memories of being around the Furry Glen and getting myself a bottle of orange and a cake or something to have lunch and being em thinking to myself I wonder could I build a tree house and live here you know.’

(Visitor 16, Chesterfield Avenue, 5th April, 2006)

This account suggests the development of an identity beyond that of the young boy’s ‘normal’ life. By ‘finding his own place’ within the boundaries of the Park, he is attempting to ‘find his own place’ within society, and by going into a free space, a space on the margin of his social world he is able to control the ideas of belonging and inclusion within this space. By bringing the bottle of orange and cake which he has bought with money he had earned, he is able to make the space special, and be different to the mundane of his life. This space has then taken on a ‘social centrality’ that is invested with values that express an alternative to the existing society (Hetherington, 1998: 124). The ordinary person when in the liminal state of transition is free of the forms of status. The eutopia (good place) of the Park in this account can be coupled, as More did, with outopia, as it is a no-place, a position removed from the ‘real’ of society and instead occupying a marginal, removed location within the imagination. This leads to the idea of utopia (More, 1985), an imagined place with perfect societal ideals, which can act as a model for future society. The idea that the Park is in some way utopian may appear to extend the meaning in the quote above too far but it is important to recognise the importance of these hidden places where ideas and identities are formed. The Park is a margin, a liminal space, between different ideas of identity and ways of understanding the past and the future and, as a space for a young boy to escape to, it provides an appropriate alterity from the mundane to facilitate an alternative expression of identity that was important enough for the visitor quoted above to remember almost forty years later.

The Park does feel like a magical place in many ways, the vastness of the space so close to the city, the tranquillity and the beauty all add to feelings of escape and release, while the natural beauty is awe inspiring. The construction of the

Park to feel like it comes from a previous time, a time without the modern life stresses. also adds to the feeling but the natural beauty is what offers the most striking distraction. The freedom associated with Phoenix Park stems from this, and the recognition that it is a space away from the 'centre' of the city, and of the life associated with that space is the next theme which emerges as important for the residents and visitors.

3.1 A Natural Place

The understanding of Phoenix Park as a natural place, removed from the human structures which mediate life in a city, or in the 'centre' of society, runs through participants' ideas of the place and the meanings they associate with the Park. It's an 'oasis out of the city life' (Visitor 10, Chesterfield Avenue, 5th January, 2006), a 'haven of tranquillity' (Resident 4, questionnaire), a place 'away from the hum drum of the city' (Resident 6, questionnaire) because it's 'unspoilt land almost in the centre of the city' (Resident 4, questionnaire), a 'natural beauty' (Resident 4, questionnaire) and a 'vast country setting in the heart of the capital city' (Resident 3, questionnaire). These quotes demonstrate the way in which people understand the Park as 'natural'. It is placed in opposition to the hectic, busy, noisy, ugly, unsafe city as a place where these things do not figure. This is of course a not an accurate belief as the Park is a site within modernity just as the city is, it is just presented and performed in different ways and the ways in which people are expected and anticipated to perform and present themselves is different within this alternative site. The idea of the natural falling in stark contrast to the social returns this discussion to ideas of binaries, and their inability to capture the complexities and nuances of the interaction between the two concepts. The associations connected with it being a natural place centre around ideas of relaxing, de-stressing, beauty and safety. But the Park is a natural space that has been socially constructed in a manner which negotiates a meaning within the public consciousness. It develops an illusion of nature, created from scratch essentially, and then re-presents this back to human audiences in a cultural performance which, in Phoenix Park, is mediated by the colonial structures which defined the space from its development as a park.

While cultural in its construction, consumption and production, the Park is controlled by the natural in many ways: the seasons mark the most striking influence of nature on the Park. Through the different seasons the uses of the Park and the appearance differ considerably. The time the Park is approached, whether it is the month or the time of day alters the way the Park can be understood, as discussed in Chapter 7 in relation to the night time activities and below in relation to different times of the week and day. The social is mediated by the natural in as much as the natural is mediated by the social; the two are intertwined in the space to produce the Park.

3.2 A Social Place

The Park is a social space, where people arrange to meet and walk. It accommodates different social activities, and functions, at different times of the day and week. In the morning it is a place where dog walkers and joggers come, and the continual stream of ‘powerwalkers’. These people are determined; they know their route and stick to it, walking briskly and purposefully, often with earphones in and heads down or eyes fixed on a distant point straight ahead. There are also a lot of cars being parked along the roads, and the people walking from these into the city. By mid-morning these people have been replaced by a group who move more slowly, seem to take in the Park more. There is a group of older men who meet outside *Áras an Uachtaráin*, trickling in from different start points. As one of these men who was sitting in the People’s Flower Gardens reading a paper at the time of the interview describes,

‘Oh I love to come up here. I come up here everyday. You know, as a matter of fact you might see me later on, I dunno if you are going straight up there or not. Normally I come up, I sit down and read the paper and eh after about an hour then I walk up and meet another few friends up there, around the President’s house around that area and we just sit and we talk, we might talk about the football that was on last night. We might sit there for an hour or so, it just passes the afternoon, and it’s better than sitting in the pub isn’t it?’

(Visitor 3, People’s Flower Gardens, 10th October, 2005)

This ritual maintains the men’s social ties, and is centred on the Park as the site for this activity. It provides exercise and most importantly contact with people.

By the early afternoon, the Park is filled with people on their lunch hour away from work, walking, jogging or eating lunch. For many, they incorporated an exercise regime into their lunch breaks, which means between one o'clock and two-thirty the Park becomes a bustle of activity, and the paths are full. The restaurant beside the Visitor Centre is busy, full of business men and women. This makes the restaurant feel like it is in the city centre, busy and bustling with seemingly important conversations occurring over cappuccinos and lattes. Cars stream in and out of the car park, and parking spaces become sparse.

The Park returns to a quieter state following this time, and the paths are returned to dog walkers and strollers. Some school students walk home through the Park, and there is an increase in cyclists. By five o'clock the Park is at its busiest, with people making their way through the Park home by foot, bicycle or car and the owners of the parked cars returning to collect them and make their way home. Traffic is heavy; sometimes there are traffic jams. After an hour or so, this swell subsides and the Park becomes quiet, with people gradually thinning out until dusk falls and the Park is plunged into the night. The night brings its own activities, discussed in the previous chapter, and by driving around the roads during night time it is possible to see signs of prostitution occurring. There are cars parked in secluded places, and men and women walking various routes. The areas where drug taking and joy-riding are reported are dark and forbidding, and there is a real sense of danger going into them. There are no people walking around these areas, and cars move swiftly through. The lights of the main Avenue do not extend into these spots and the surveillance of the Rangers seems not to either.

At weekends there is a different ebb and flow of people, a more continual stream of people for different kinds of recreation; walking, visiting the zoo, playing sports, painting, photography, kite flying and picnics. The pace is gentler, the days more relaxed and there is a sense that time is frozen for the hours of the day, it is not structured like the busy weekdays. This social and natural place holds its own social and natural time; the seasons change the Parks function and aesthetic, and the social activities change accordingly, there are different influxes of people, at different times and for different reasons. The natural time of the Park,

however, is colonised by the social time; no longer are activities controlled so much by the fall of night, the nights along the main avenue illuminate that area, and the areas which remain dark are used for prostitution and drug use, activities that benefit from the cover of the night. So, the Park is temporally divided socially and naturally; socially there are different functions and different groups using the Park, and naturally there are seasons that change the flowers and trees, and control the night and day.

The Park has many different uses and meanings; they all come together to make this place. The accounts used above have begun to describe the way people understand the Park, and this section has focused on the Park itself and the way visitor and residents ascribe meaning to it and understand its position. The next section is going to extend this, and place the Park in relation to Dublin and Ireland, to see what position it holds as a significant site for ideas of Irishness and Ireland.

4. The Irish Park

The way in which this space has changed through the different epochs and paradigmatic understandings of management, function and underlying ideology is as important in the meaning it holds in the public imagination as in the manner through which these forces have acted (which has been the focus of Chapter 7). The position the Park holds in relation to ideas of Dublin and Ireland, and the way in which it is understood as being part of these places provides insight into the position the Park holds for the city and country on a local level and for individuals. By understanding the way this may have changed through different times, we can begin to focus on the postcolonial ideas surrounding the place and associated identity. This national significance has been developed in Chapter 7, so some themes which were more peripheral in the interviews though prominent in the previous focus have been omitted to avoid repetition.

The first meaning attributed to the Park is as a greenbelt, the 'lungs of Dublin City' (Resident 1, questionnaire). While there are a number of other smaller parks dotted around the city, Phoenix Park is regarded as the most 'natural' (Resident 4, questionnaire), thus providing green open space and a place for

people to go. This has become important as the population of Dublin has increased and there has been a need for recreation facilities for the growing population. As one resident describes,

‘The value of the Park to Irish people and in particular to the people of Dublin is more now than ever before. Dublin has become over populated in recent years just look on the outskirts of the Park.’

(Resident 4, questionnaire)

The construction of apartments all around the Park, and most recently on the Phoenix Park racecourse, has meant that the Park has become an excellent selling point. The advertisements emphasise the benefits of having the Park so close by, mitigating the lack of garden the flats and apartments offer, and the price of these new dwellings suggests that it has worked. The increasing focus on exercise and fitness has also meant the Park can ‘market’ itself to another audience, highlighting the cycle paths and jogging lanes. As a resident recognises,

‘When you consider that we live in an age of the environment, leisure, fitness and physical well-being then the Park becomes very important.’

(Resident 1, questionnaire)

The Park does provide an unusual blend of recreational activities; you can walk gently or partake in one of the more ‘active’ sports as catered for by the wide range of sports clubs that are based in the Park. There are football and hurling pitches, polo and cricket grounds, and as such it is a place where both sports-people and supporters alike can come to enjoy their chosen sports. In this way, it is a very important place for the people of Dublin, and on occasion all of Ireland. The uses of the Park do position the Park in the people of Ireland’s conscience, as demonstrated in the previous chapter.

A theme which ran through the responses of many of the participants in response to this question was the idea that, in fact, many Irish people took the Park for granted. This related to both the open space that has for a long time been associated with Ireland and also the activities within the Park. Indeed, as this account demonstrates the Park is regarded as a place where things happen that could not happen ‘in England’, an interesting point of comparison that develops from the discussion in Chapter 6 on modern cities. As these two visitors discuss, the Park is a place where activities can occur unregulated and space is enjoyed

freely, and if either of those things were threatened it would be a negative thing. The Park is associated with freedom and an absence from the negative signs, though not a lack, of control.

Visitor 14a: 'Just that there's things you can do here that you can't do *even in England* for instance, you know you can go to here and look at polo for instance, polo is free here. And polo, to go and see a polo match in England is very expensive and highly exclusive and all that. So.'

Visitor 14b: 'Maybe because it was just always here we took it for granted.'

V.14a: 'I think Irish people take open spaces for granted, maybe more than other people. Ya know, we regard it as our entitlement. We get very upset if somebody comes along and puts a fence up and says we're having a rock concert you can't stand here. You get very annoyed with that happens.'

(Visitor 14, Papal Cross, 3rd March, 2006)

The juxtaposition with England in this account is interesting on many levels. The visitor has identified England as a place where freedom is available, though the Park has exceeded this, at least on the polo pitch. However, in the second part of the statement, he recognises that in England it is more expensive and exclusive to attend polo matches, perhaps demonstrating a class association, which is removed in the Park. Phoenix Park's polo is seen as more egalitarian, available to all for free. The ideas of freedom associated with England, and the UK, in Ireland can be understood with recourse to a number of things²⁸, and of particular note is religion. Catholic Ireland was more reliant on the Church, through the relationship between church and state, whereas England and the UK enjoyed a less imposing religious order. In addition there is a continued, though continually diminishing, view that England and the UK in some way represents a more modern country, with a traditional Ireland lagging behind and playing catch-up, a position imposed within the colonial experience and still important in postcolonial society. This view has continued as Ireland has remained economically dependent on the UK for much of its independence, again an occurrence which can be linked to colonialism, and only recently, since the Irish Celtic Tiger has the Irish economy grown faster than its neighbour. For there to be things that you can do now in Ireland, and *not even in England* makes it exceptional, and demonstrate how culturally the Park breaks from assumptions and ideas about the relationship between the two countries and the how overall

²⁸ Class, the development of industry and economy, comparative income, position in the global economy, history, are all factors as well.

there is a move away from viewing England and the UK as a neighbour that continually needs to be competed with. These legacies from the colonial encounter make England and the UK a yardstick to be reached or to judge by, as it is ingrained in the culture of Ireland to aspire to this standard.

The relationship between Ireland and the UK can be understood in the context of the past, and for many of the visitors this reverberated in their accounts of the Park and the importance it holds for the Irish people. The continuation of violence in Northern Ireland makes the 'Troubles' a very real occurrence and many Irish people are still living with first hand memories of events relating to the 1922 War of Independence. However, the attitude towards Britain was consistently positive, with people looking to the future, and often aspects of the past, with hope and fondness. The Park holds a unique position in Dublin in that the Wellington monument, a tribute to an (albeit Irish) officer in the British Army, has remained to this day. However, the statue of Lord Gough was first decapitated and then blown up by the IRA, and was never replaced. The Park management is eager to replicate this statue to restore the Park to its 'original' form, but as one visitor commented,

'It's just as well that he's [Lord Gough statue] gone because the Trouble you know what I mean it caused more trouble than anything else you know what I mean.'

(Visitor 8, Chesterfield Avenue, 5th January 2006)

As the visitor concludes though,

'Cos yea well, we're nearest to the British and we're good friends with them now so let's hope that we can just keep it up the whole lot.'

(Visitor 8, Chesterfield Avenue, 5th January 2006)

This view was common, and most people were able to comment on the fact that the British developed the Phoenix Park among other important sites, and that this was a good thing. As one visitor describes,

'It has a deep colonial history. Yea, well everything is a remnant of the British. They're all remnants and I suppose it colours everything really doesn't it? And that's a very good thing in lots of respects, I mean they did plenty and I often wonder to myself I wonder had we not got so called independence and we had stayed as a satellite of England would we have evolved much the same anyway

like Scotland or Wales. So I mean would we have been any better off or worse of you know. I do wonder you know. And it's very sad our history you know, and even up to present day all that kind of thing.'

(Visitor 16, Chesterfield Avenue, 5th April, 2006)

This view seems to mitigate any negative feelings towards the British and understand the history in a very progressive way²⁹. However, the point that 'everything is a remnant of the British' resonates strongly with postcolonial theory and the epistemological footprint the colonial process left on Ireland. The way of understanding the world and views of development are strongly influenced by the colonial methods of developing the satellite countries. On a material level, the visitor is correct in observing that most of what exists in Dublin architecturally today does stem from that time, the form has remained unchanged even if the function is different in most cases.

The view that Irishness does stem from this time and that it is necessary to embrace this postcolonial identity is fundamental to this thesis, and the view that whilst the remnants may be strongly British and colonial that does not mean that the meaning and understanding associated with them has to be so reductionist as to presume this is all that can exist. The account above offers a way of understanding the past, but it must be coupled with an understanding of the present which allows an identity to exist that recognises the past and uses it to understand the present and develop a future. In middle class Dublin there is a move towards a post-nationalism, an identity that is defined by affluence and globalisation, and it is evident in some accounts that the situation in the past and even in Northern Ireland today is not very important to their sense of identity (Finlay, 2006).

5. The Changing Park – Transformation and Transition

The changing Park has influenced people in different ways; for some it meant a new way of understanding their employment, and a change in role from the historical family position. In addition, security issues have been constant in the

²⁹ Research bias, as discussed in Chapter 4, must be restated here. Though Irish, some visitors perceived my accent as English and this may have caused them to say what they thought would be politically correct. A tactic for avoid conflict called 'telling' (Finlay, 1999) has been researched in Northern Ireland, and it may be that it is also used in the South to avoid offence or provoking negative responses.

Park, understandably with a space this size, but the perception of the crimes has altered, and the perceived influx of drug and drink related activities is viewed in conjunction with the decrease in personnel employed in the Park. In 1961, there were 160 people working in the park, and by 2005 this had decreased to 75. This has meant that the family links which characterised the jobs in the Park have fallen aside, as sons who would traditionally have followed in their fathers 'footsteps' search for employment outside the Park walls. As the son of one of the residents said,

'Of course years ago there were a lot more people in the Park, you're coming to it at a time when the work force has been severely depleted and em so that years ago there were gangs of men doing manual work around the Park and so now that doesn't happen anymore and there are no permanent gate keepers on the gates and there's a lot less people employed than there used to be so that's a bit of a disappointment to the surrounding areas as the Park isn't giving as much employment as it used to. It wasn't top class well paid employment but it was employment you know'

(Resident J son, interview, 23rd October, 2006: 17 - 23)

The 'park constables', or Rangers as they are known now, are the oldest police force in Ireland, with powers to arrest and hand suspects over to the Gardaí. However, the residents who used to work as Rangers see a change in the position. The standards of attire and ceremony have decreased; the rangers used to be subject to parade and inspection by the Chief Superintendent, Assistant Superintendent and the man in charge of stores, to make sure they were presentable to the public and appropriately dressed (Resident J, 23rd October, 2006). This was associated with control within colonial rule, and military connotations seem to be strong. The uniform of the Rangers used to be more formal, with different helmets for the summer than for the winter. There was a display of order and attention to detail, something replicated in the work carried out by the men in the uniform. The Rangers didn't have the jeeps they do today to move around the entire Park or ability for instantaneous communication, and so it was important that everyone was very clear on what they had to do and how it should be done. There was a hierarchy among the Rangers according to different ranks and conferred seniority, something which has also been disbanded.



Picture 9.1 Photographs of the Rangers in the 1930s (courtesy of Jim Manning)

In contemporary times, the role of the Ranger has shifted to one of patroller, and the range of activities they would carry out has decreased, along with their power within the Park. While the Rangers retain power of arrest it is not something used regularly. However, previously it was exercised with regularity, a privilege necessary due to the solitary role of the ranger as patrollers on bicycles, each with a designated zone of authority³⁰, and lack of ability to communicate with others quickly. This shifting role for the Rangers epitomises the shift in management strategies in the Park, as discussed in Chapter 6. There has been a relaxation of standards, enforced by cut backs and a constant struggle for sufficient funding. The numbers working in the Park have dropped dramatically which have meant the standards have been changed, and parts of the Park have had to be closed off to through traffic which makes them attractive sites for illicit behaviour. As one resident summarised,

‘It was kept better years ago, there were more men employed to do things like edging the grass, it was more cultivated, it’s wild in parts now where they have closed off roads and because of this unsafe to walk.’

(Resident 6, questionnaire)

The mechanisation of tasks, and the shifting role of the Park, has limited the growth of employment, leading to the loss of links with the villages of Chapelizod and Islandbridge which were forged through employment. The lodges within the Park were solely reserved for the Rangers and Gate Keepers but in the late 1970s this changed, and many of their residents were kept on as caretakers to avoid the lodges being empty, changing the role of the Lodges and

³⁰ The park was divided into 5 different zones, each with a Ranger in charge. The Ranger would live in this area, and patrol it through the day.

the presence of Rangers in the Park. Now, most of the people who live in the Park have done so for a long time, and many of them are retired, or the widows of people who worked there. For them, this reflects sadly on the Park; the transitions are negative. The eldest resident is a 97-year old widow of a Park constable who has lived independently in her cottage since her husband died, more than 30 years ago. It is summarised by the Chief Superintendent,

‘In the early 1990s there was no interest among staff in living in the houses. You had to encourage people. A lot of the houses are cold, and the smaller lodges were originally built as a house for one. They’re more picturesque than comfortable and not really intended for families, although some were extended in the past.’

(Chief Superintendent, in Cleary, 2006)

However, there is a very recent shift in this attitude, and now there is a reported waiting list for houses, as a place in the Park becomes more attractive in a traffic-choked city in the grips of a property boom (Cleary, 2006). As the Chief Superintendent recognises, ‘they are little gems of architecture, these houses, and the OPW has a policy of restoration’ (13th December, 2005), though he also recognises that ‘life in a chocolate box house is not all sweet’, with small windows and thick stone walls there are problems with heating and light.

An associated shift in function can be found in the Park. It used to be used for cattle grazing and hay making but the cattle stopped being brought into the Park in the early 1980s due to an incidence of TB³¹. Cattle were allowed into the Park between the first of May and the first of November for grazing, and this meant that the Rangers had to perform duties outside the remit of today’s workers. One of the residents who worked as a Ranger for over forty years gave this account,

‘And further more, my job as a Ranger, I was picked out and given the job of branding them [the 1000 head of cattle]: cowboy! We used to brand them on the hoof, each owner had a number so that number had to be branded with a hot iron onto the hoof and then another man would come after me and put an ear clip in after me. So that was my job, once the cattle were coming in, I would have that job as branding. I often think of if the Rangers today were given that job it would be a whole new ball game for them!’

(Resident J, 23rd October, 2005: 17 - 25)

³¹ It was believed to be the deer that were transmitting the disease, but in fact later it was concluded that it was badgers.

Indeed the Park looked different as a result of the agricultural activity occurring within its walls, and the work on it was different as well. As another resident who was a Ranger describes,

‘I commenced work here in 1955 coming from a rural background [and] it almost looked to me as a huge farm. It was summer, and with a thousand head of cattle grazing on its lush grassland together with the deer herd of 350 and a couple of dozen wandering horses it was beautiful.’

(Resident 4, questionnaire)

As another resident, a son of a farmer describes,

‘We would save hay for the deer and cattle. It was farming, in a minor way. My job was very fulfilling. When I was working [he retired 10 years ago], I enjoyed all four seasons. Work was dictated by the seasons. In the summer, there would be grass cutting, then planting in the spring, clearing leaves in the autumn and tidying up in the winter, like you would on a farm. If I had to leave the park and live outside, that would be a wretch.’

(Resident M, in Cleary, 2006)

These idyllic descriptions captures the dual functions of the Park in that time, as an aesthetically pleasing, highly cultivated and manicured Park and as a place that provided local farmers with grassland to graze their cattle. In contemporary times, this dual function has been lost, and the facilitation of agricultural activity has been removed from the Park. However, one of the residents (4), the retired Park foreman, describes of the contemporary Park, ‘Living here, you’re in the country but you’re also in the city.’ The shift of responsibility of the rangers in the Park can be used metaphorically to also demonstrate the shift, as described by Bauman (1987), from a gamekeeper society, where the state was not bothered to give society an overall shape and was uninterested in the detail of it, to a gardening state, that is concerned with pattern, regularity and ordering, with what is growing and what is weeded out. However, in the Park this metaphor can be continued, as the gardener is getting tired, and the level of interest is waning, marking another transition in state interaction with society. Urry (2000) argues that society is returning to the gamekeeper model, based on the increase in mobilities that alter the way we understand civil society, the state, nature and the global. No longer is there a tight level of control that can order what happens in clearly demarcated boundaries, but there is regulation of herds moving in and across land. In addition, the strict division between the gardener and the garden

is not in keeping with the relationship between nature and society demonstrated in this thesis and advocated by Urry (2000).

This is not the only activity to be 'lost' from the Park. The place Phoenix Park held in many people's romantic history deserves mention. The Furry Glen was the place to bring your 'date' and many couples have been formed and marriages proposed on that stretch of land. For one resident, the couples in today's Park remind him of the importance it once held, and how the present is linked to the past and continues on certain traditions.

'I often see courting couples walking in the Park and think one hundred years ago the Park was used by couples. In those days Ireland was a poor place, and the Park was the main dating area in Dublin. No cinema, no Temple Bar, no nightclubs, just the Phoenix Park.'

(Resident 4, questionnaire)

While it may no longer be as central a part of contemporary couples 'courting', it certainly figures in the next stage, as it is popular with people walking buggies, teaching kids to cycle and having picnics. During the weekend, the Park comes alive with children and families, as it offers safe extensive grassland for them to play on, the zoo to visit and different sports to watch and participate in.

Traffic marks one of the major differences between the Park in the past and in contemporary times. With over 25, 000 cars passing through the Park in a twenty-four hour period, there is an almost continual stream of traffic running along the main avenue. It has transformed Chesterfield Avenue into a thoroughfare, rather than a quiet road in the Park or a place you could cross with ease. This transition has implications beyond a shift in function of the road; the cars potentially influence the whole Park. The Chief Superintendent notes that it is 'a planning miracle that the Park has survived from the 1660s to today' (in Cleary, 2006). By increasing the amount of traffic there is increased air pollution and noise pollution, factors which eventually could affect the whole area. This theme will be picked up again in the Future Park section below, as it is one of the main concerns for the future held by the residents and visitors.

On a similar theme, the safety of the Park is raised as something which has decreased in recent years. For an area the size of the Park, there is actually very little crime, with petty theft occurring primarily around the zoo and the parked cars on Chesterfield Avenue. Pick-pocketing is virtually non-existent, and there is very little danger walking through the Park during the day. However, the Park has experienced atrocious crimes which have entered the public consciousness and tainted the Park's reputation as a safe haven. Incidents as distant as the Cavendish Murders portray the Park as a site where crimes as dreadful as murder have taken place, and there have been contemporary incidents that have reinforced this belief. In response to a question about the Park's position in history, one visitor recapped the various murders in the Park,

'Em, now there was another...there were a few murders up there. There were a couple of German backpackers, yea, on the left hand side near enough if you're going up that way on your left hand side to the last football pitch. There's a clump of trees, like a little forest and two German back packers they didn't know that you weren't meant to, well they didn't realise the danger they were putting themselves in, [because] there used to be fellows there drinking cans and all that. And they went in there to camp for the night eh one of them got murdered right, but eh some fellows did time for it and all that carry on, I don't know what happened the other chap. I think he was injured but he didn't die, but one of them died. I remember that. Now. Then there was another do you ever, now you'd be too young but your parent's will remember eh she was a nurse, she was out of James's hospital. It was in the summer. This fella, now what's his name, McArthur, he's still in prison, right, eh he killed a nurse up here. She was sunbathing and he killed her with a hammer you know. And eh she was from James's hospital. She was a nurse. She was only just on her break.'

(Visitor 3, People's Flower Garden: 10th October, 2005)

This view that there is a large amount of crime in the Park is reinforced with references to drug use and prostitution at night time. However, prostitution has always been a feature of the Park, with one of the Rangers recounting how he often had to move the 'ladies' out of his area, when it was divided into five zones.

'And then at that time, we had something we don't have today, we had girls that came in here, prostitutes and they would have various roads that they would parade along and they would have to be moved, out! But we used to do that; you'd say you have to move off my patch, you'll have to move off it.'

(Resident J interview 23rd October, 2005: 19 - 24)

The shift from predominantly female to predominantly male prostitution seems to have stigmatised this activity further, coupled with the activity occurring solely at night. In addition, the Park is used as a site for underage drinking, 'cider gangs' as one participant described them. This participant had been confronted by one of these gangs when he went to inspect an old building. He describes how the area was controlled by these youths and how he was scared about a confrontation.

'But it's an area that at night time it's just a no-go area, like the cider gangs, there's still a problem in the park, you get these rambling cider gangs going through the park. Teenagers drinking cider. They go from woodland to the other, but this you see they used this to get into the building, and it was impossible and you get like 50 or 60 of them in a gang so like the cops were just containment, but like the group was too big.'

(Architect, 9th May, 2005: 456 - 460)

While this has decreased, as the Gardaí have moved to clamp down on it, it was a substantial problem in the 1990s and these gangs were responsible for the burning down of the building which stood on the site of the Visitor Centre. The problem of alcohol in the Park is now overshadowed by incidences of drug use, and especially heroin. This activity is highly stigmatised, causing people to view certain areas as no-go areas today. The closing of tributary roads to Chesterfield Avenue, which means areas of the Park have no through traffic and are poorly lit, exacerbates this. One of the residents discusses the change which has happened with attitudes towards safety in the Park,

'Ah it was a very small occurrence [crime in the past] but people got it into their heads like that they might be in trouble, now today's a different ball-game, it is dangerous. It is. I wouldn't say all the time, but at certain times. Especially at night time. Yea it is. Now we have a great incidence of, I don't know if you know it, but of people with too much alcohol, and we have drugs. We have people who come in here, and the common term is they shoot up, they come in here to do it.'

(Resident J, 23rd October, 2005: 21- 26)

The lack of Garda presence has been amended, and there are now units on foot who patrol the Park, along with Rangers in Jeeps, but it is such a vast space it is impossible to 'police' every corner, and the occurrence of illegal activity seems to be controlled to a very impressive extent, with crimes which are dangerous to people other than those who chose to be involved at a very low occurrence.

These shifts reflect a change in the way the Park is managed; there is a decrease of personnel which has led to a decrease in the attention to detail, something which is lamented by those who knew the Park before this occurred. However, if you had not seen it as it was then it is still a remarkably well kept Park, with impressive planting of flowerbeds and trees that continues to reflect on the high standards set during the Victorian halcyon days of the Park. This is what is achieved, a generous acknowledgment of those days, replicated in the planting and manner in which the Park is kept, though not quite achieving the rigorous standards set during that period. Perhaps this is because of the ideology of the management, the backward looking gaze which keeps the Park's focus retrospective. As one of the residents remark,

'There are lots of things that could be done with the Park but the mindset of the Government is to keep it in the Past'

(Resident 5, questionnaire)

This sentiment may be exacerbated by the feelings of removal that people experience when they stop working in the Park; some years ago there was talk of forming a residents' association among the households in the Park but nothing came of it. As one of the working residents said, 'a lot of people, when they retire, the park tends to lose touch with them, even though they still live here' (Resident M, in Cleary, 2006). This was also expressed by the Head Guide, the feelings of isolation that could be associated with living in the Park; the spatial separation of the houses is vast and could lead to these feelings, especially as the residents get older.

6. The Future Park

From the previous section, it is suggested that the Park is in transition, between a highly regulated, controlled regime to something else. However, as it is in transition, it is difficult to know what the future holds for Phoenix Park. There were mixed views from visitors and residents to the future, ranging from the view expressed in the above quote that the government is actively promoting a nostalgic, retrospective position for the Park to people who felt that the Park should change and adapt for the changing society in which it existed. However,

the overwhelming sentiment was that the Park should remain the same, questioning the linear progression associated with Turners liminality. Reverting to the liminality of Bhabha, it is important to recognise that the process may not be linear in the sense that Turner understands it; there may not be progressive steps toward something, simply a shift in the way it is understood, formulated, and constructed; the movement is rhizomatic. Whilst the shifts are obvious in the way the Park has changed, what is not obvious is where it is going, and how it will eventually get there. As the quote in the opening section of this chapter from Bhabha identifies, the post of postcolonialism should be regarded as a way of recognising transition and transformation, not simply read as a linear progression away from colonialism, in an ordered, structured way. This section will organise the ideas people have about the future, though it is interesting mostly for what it tells us about the present.

The main changes that people perceived and highlighted as threats for the future were the increase of traffic and the prospect of development. This threat was understood as being the agenda of an 'other' group; either perceived as an unknown threat, or named in wide categories such as 'councillors' (Resident 3, questionnaire), Dublin Bus or the government (Resident 5, questionnaire and Superintendent Interview, 21st June, 2005). This unknown is positioned against the Office of Public Work, the Management, and the local residents associations, who are seen as guardians of the Parks values and land. As one resident described,

'I fear when you hear councillors talk about running bus routes through the Park that they don't realise the gem they have. I have every faith that the Office of Public Works with the local resident association will insure the Park remains as it is. But who can tell the future?'

(Resident 3, questionnaire)

The sentiment of keeping the Park the same threaded through the different interviews and questionnaires, though in fact it is difficult to know how this could be done. If the Park is understood as a natural site, then it is constantly changing, through the seasons and over the years as plants and trees grow and die. Culturally, the Park is continually shifting in its meaning, and the uses and importance of it shift alongside this. Some regard the shift in function with

suspicion, as an indication of the changes which are already encroaching on the otherwise preserved space.

'Keep it like it is. Keep it like it is. The only thing that has started over the past few years is that they're doing gigs up here, and a lot of people were against that. I personally don't have a problem with it but it wouldn't want to go beyond that, that it stays quiet and that, because that's the reason you come up to just relax and that'

(Visitor 10, Chesterfield Avenue, 5th January, 2006)

The inclusion of new activities in the Park has aroused suspicion regarding the future, and some feel that it is the beginning of the encroachment of development onto the Park. The need to protect the space for future generations and for the public came from residents who worked there, as one Ranger and resident said,

'I know for a fact from my dealings with Joe Public that they would not take too kindly to their Park being interfered with in a negative manner. a) The Park is important b) the Park's future needs to be assured c) Future generations will applaud this.'

(Resident 1, questionnaire)

In 1998, permission was given for development to occur on the site of the disused race course in Phoenix Park. The planners, in acknowledging the importance of the site as a greenbelt between the city and Blanchardstown, agreed to back a proposal which would see around thirty percent of the one hundred and four acre disused racecourse devoted as parkland in a bid to placate opponents. It worked, and there are now premium apartments being sold, using the Park as one of the main selling points. The Park has meant that transport around the area is now being improved, a point that one of the advocates of the development, Tom Morrissey of the Progressive Democrats political party, highlights,

'The developers are committed to building a new train station in Castleknock at a cost of €4 million. I have secured a commitment for Iarnród Eireann that the rolling stock will follow. This would not be possible without the Phoenix Park development. The new station will also boost a Park 'n' Ride facility with space for over 100 cars. The new development is on a national primary route within the M50 corridor and has a Quality Bus Corridor along its entire perimeter. It is bounded by 1700 acres of the Phoenix Park – a fantastic local amenity – and yet the Labour Party is concerned about a 100 acre derelict site beside it.'

(www.progressivedemocrats.ie/press_room/2265)

This argument supporting the development is compelling, and the growth of a transport infrastructure has important environmental importance, but if it

signifies the beginning of pieces of land being 'shaved off' the Park for development it is a dangerous initiative. This piece of land was seen as separate from the Park because it was no longer used for the purpose it was intended for, as a race course. As the Park changes and pieces of land are viewed as 'outside' the main body of the Park, such as areas where there is male prostitution or drug use, it may become possible to label them in the same way. The Park is now centred on Chesterfield Avenue, and the major regeneration goes into this area, beautiful with park benches and lights it signifies all that the Park wants to be associated with. The other areas in the Park that are wild and untamed fit into the current view of the Park, but their position may be threatened by idealism and nostalgia, and removed from the idea of the Park, and then the material Park.

As a final view of the future, it can be understood as a way of reconceptualising the past. This view overwrites the linear continuation of the Park with a cultural significance to the way in which people can understand the Park and the history associated with it. As a visitor reflects,

'The future lies in the past in a sense. You know the future can be understood by the past, if we understand the past there's a hope we can fix the future.'
(Visitor 16, Chesterfield Avenue: 5th April, 2006)

The Phoenix Park does do this; it is a postcolonial site where transition has occurred in the function, the management style and the underlying ideology. The way people understand and experience Phoenix Park is not the same as it was two hundred years ago or indeed one hundred years ago. There is acceleration in the way the Park is changing, as there is in the surrounding city. People identify with the Park's history and awareness of its previous use is high, but it means something else now. The past has not been forgotten, nor has it been moved away from, instead a cultural space has been produced that deals with the history and provides ways of understanding it that must be understood as a hybrid site for identity; a mixture of identity that cannot be pulled apart to expose the composite parts, but instead is something that comes about when people are not even sure about the origins that they are referring to, or how they can be understood. It is a fragmented identity, but a natural site and a changing space hold it together.

7. Conclusion

This chapter looked at the way in which people understand the Park and the different transformations which are occurring within it. As part of this ideas of time and place are extended, developing them in relation to previous themes in the thesis. Different accounts are used to understand the ideas of transition which are occurring, or have occurred and these are positioned in a manner which addresses ideas of identity as related to place. The shifting topology of the lived environment in Phoenix Park has lead to changes in the understandings and perspectives people hold about its place in society and their place within it. The Papal visit accounts demonstrate the ideas of modernity that are associated with the event in the Park and the collective feelings of achievement, the next section stands in opposition to this, looking at the Park as a natural, magical and social place constructed by the understandings of the space in these ways. The ambivalence of understanding marks the space as liminal; a site where there is a hybrid identity composed of different origins and meanings. The section discussing it as an Irish Park looks at comparisons with England and the UK, something found through the Parks literature in the continued use of the idea that the Phoenix Park is bigger than all of London's parks put together. The statue of Lord Gough is discussed from the perspective of the visitors and residents that the statue caused more trouble than anything else, standing in contrast to the 'official' position that it should be returned. These two key themes are understood as colonial remnants and the ways in which they are understood and the meaning associated with them are quite different, something which is also developed in this chapter. The next section, the changing park, looks specifically at the changing management style from controlling the Park to managing it and how this is associated for many with a 'decline in standards'. The shift from a controlled, structured, regulated space to a space that has wild and uncontrolled area is lamented by the residents and people who work there. There are negative changes also occurring that represent the intrusion of modernity; the increase in crime and cars. This chapter ends by pondering the idea of a future Park and what it might look like, though this is used to inform our understanding of the present.

As part of this chapter, there has been a problematising of the linear progress nature of Turner and van Gennep's transitional stages. Adopting the postcolonial understanding of cultural development, this chapter highlights the necessity to understand the rhizomatic, non-linear movement of the Park through different epochs, and the accompanying uncertainty about what the future holds. This chapter presents the idea of the Park from the visitors and residents, sometimes contrasting with the official accounts presented in the previous three chapters and sometimes presenting a complementary view on the issues; it offers a more 'ground level' appreciation of the space and understanding of the history. It delivers an important piece in the picture that this thesis is constructing and a valuable view on the events that have shaped the Park.



Chapter 10 Conclusion

'We must be consistently aware of how space can be made to hide consequences from us, how relations of power and discipline are inscribed into the apparently innocent spatiality of social life.'

(Soja, 1989)

1. Positioning the Thesis; Introducing the Conclusion.

This thesis has addressed the main ideas and conceptions of postcolonial theory in an empirical setting, examining what it means and how it is manifest through different representations and techniques of history, culture and social understanding. The material presented has been local and contingent, focusing on Phoenix Park in Dublin. As such, any claims must be understood as suggestive and illustrative due to the qualitative, in-depth nature of the research, though it has pointed to certain key themes which develop overlaps between ideas of spatiality and postcolonial thinking and understanding. The purpose of this concluding chapter is to explicitly identify and discuss these themes and position them within a wider sociological understanding and imagination. The Park has been discussed with reference to a number of key findings which have emerged from the empirical study. This has developed the ideas put forward in Chapters 2 and 3, as they have applied them to the real life setting of the Park and expanded the ideas critically through this application to the local setting. Initially, this chapter will position the work in relation to some of the theory that has not been prominent in the thesis but which helps understand the stance adopted and the relevance of the work on a wider scale.

'Modernity is inherently globalising', writes Giddens (1990:63), evident, he goes on to say, 'in some of the most basic characteristics of modern institutions'. He develops a criticism of sociologists for not engaging with the central importance of the globalising processes, despairing at the focus on society as a 'bounded system' (Giddens, 1990: 63). To move beyond these constraints, Giddens calls

for the development of a perspective that concentrates on how social life is ordered across time and space. 'the problematic of time-space distancing' (Giddens, 1990:63). This distancing is described as a 'stretching' of the relations between local and distant social forms and events; something that is increasing all the time in this postmodern world. This thesis is situated in these stretching relations; postcolonialism is concerned with the way in which relations change and adapt depending on the different power arms stretching at any given time. It recognises the globalising processes that intensify worldwide social relations linking 'distant localities in such a way that local happenings are shaped by events occurring many miles away and vice versa' (Giddens, 1990: 64). While Giddens describes this process as dialectical, with local happenings moving in an obverse direction from the very distanced relations that shape them, this thesis has introduced the idea of a trialectic space of production, variously called a liminal and thirdspace perspective in different literatures, that complicates the relations within the dialectical model. It recognises the two spheres of Giddens, the thesis and antithesis, and adds a third cultural, social and historical sphere, where the clearly demarcated boundaries are blurred and confused. The modern institutions that Giddens mentions must be understood in another manner; not only through processes of globalisation but also with another more unsettling reading. As Bhabha describes,

'Our major task now is to probe further the cunning of Western modernity, its historic ironies, its disjunctive temporalities, its much-valued crisis of representation. It is important to say that it would change the values of all critical work if the emergence of modernity were given a colonial and post-colonial genealogy. We must never forget that the establishment of colonised space profoundly informs and historically contests the emergence of those so-called post-Enlightenment values associated with the notion of modern stability'
(Bhabha, 1991: 64)

This 'major task' described by Bhabha (1991) has been another of the main points with which this thesis has engaged with. There are many different ways to approach the challenge and theoretical engagement with these issues, and this has informed the empirical work carried out here. Primarily, the main areas that address these issues in this thesis include ideas of subjectivity and objectivity, truth claims and ideas of validity and rigour. The methodological implications have been developed through the thesis, and the colonial legacy of anthropology

and colonialism and the concurrent issues has been explicitly discussed in the Chapter 4. Methods and theory cannot be separated, in the same way as methods and findings are not discrete categories standing apart from each other. As such, the theoretical implications and understanding behind the methods adopted are discussed at some length in the same chapter. Moreover, the theoretical implications have favoured a postmodern, poststructuralist approach which has influenced the entire shape of the thesis, and the claims made in this conclusion. The material has been used to illustrate the way in which certain theoretical statements can be found in empirical enquiry; however, this is not to say this research makes any over-riding, grand truth claims. It is a piece of work that occurred at a certain time and place, being used to make suggestions about a set of theoretical positions.

Any recourse to ideas of truth is problematised on different levels throughout this work: however, there is a claim to well considered, conducted and presented research that is based in theoretically reasoned and assessed claims. The truth of this thesis lies in the empirical work and enquiry; it is a sociological thesis that offers perspectives on society. While postcolonial theory is convoluted and difficult to read and access at times³², the root of this thesis lies in the research conducted in Phoenix Park, which acts as a lens to focus upon the most salient theory. Postcolonial theory is selected as the lens through which to read the things that have happened and are happening there, and it is done so in a conscious way. The reason that this has been done is because it offers an interesting perspective and introduction to theoretical questions that are important to sociology, and a way to engage with them and think about their position in sociological enquiry. The main sociological issues which this thesis has dealt with are the importance of space as a sociological concept, the methodological issues associated with the Other and othering, and the importance of positioning enquiry historically. It also asks questions about how contemporary society can be understood, using ideas of history, modernity and

³² See for example Eagleton (1999) for a critique of Spivak (1999) that is based on her writing style. He compiles a list of 'rules' for postcolonial theorists to conform to, the second being, 'Be as obscurantist as you can decently get away with', he continues that 'Post-colonial theory makes heavy weather of a respect for the Other, but its most immediate Other, the reader, is apparently dispensed from this sensitivity.' There is significant backlash against this article in the next edition of the journal.

postmodernity. These themes will be developed in the section in this chapter which examines the way that postcolonial theory has worked with sociological methods, and combined to provide the 'sociological imagination' (Mills, 1967) for this thesis.

This thesis is situated within the global ebbs and flows (Deleuze, 2004) which make up the contemporary world. It recognises that there are numerous influences and powers which exert and shape discursive constructs which are historical, social and cultural in nature. However, this thesis does not favour a macro-perspective. The level of study is not a global context, neither is it the nation state; instead this thesis is placed within a local space and is concerned with the local strategies and narratives which are uncovered there. The social sphere of study is the understanding and perspectives of the people who operate sense-making techniques at the level of the everyday, and the way this interacts with 'official' discourses that seek to inform and manipulate that level too, developing interaction between different levels incorporating the global and national, but not having them as the primary level of analysis. The way in which this interaction has occurred has been through four main themes; the first is authenticity, the second ideas of Irishness, the third the production of space and finally, a focus on the consumers of the culture of this Park, the residents and visitors. There has been a focus on the local strategies and understandings employed by those associated with the Park, the way they understand their space, reconcile policy decisions and ideas and interpret the history and culture of the place. Underpinning all of this, this work has developed and engaged with ideas of the liminal and the related concept of Thirdspace (Soja, 1996; Bhabha, 1994). A concern about the nature of the interaction with the material space has been threaded through the thesis, using ideas of the liminal as a means of understanding this interaction. This has informed much of the empirical chapters, and the way in which the representations of the Park can be understood using this concept. The ideas surrounding liminal that have been used have ranged from a postcolonial concept informed by Bhabha (1991) to a more anthropological perspective from Turner (1986) through to a spatial use of a similar idea with Soja's (1989) Thirdspace.

2. Main Themes

The following section will unpack these themes, demonstrating how and where they are found through the thesis and developing them into a coherent commentary about the Phoenix Park and its postcolonial cultural, spatial and historical position. Instead of a review of each chapter, the overlapping themes between each will be discussed and links will be made between the different areas discussed in the substantive foci. This will help present a comprehensive and transparent argument that draws on the theoretical underpinnings.

2.1 Authenticity

Chapter 6 holds as its main theme the idea of authenticity and how this is produced developed and understood in colonial and postcolonial times. Working through ideas of façade and reproduction, there is reference to different empirical encounters that demonstrate these as important themes in the understanding of the Park. Moreover, ideas of authenticity are not found solely in this chapter but are threaded throughout the thesis. The idea of an authentic past and the search for an authentic claim to nation inform the nationalist project as a whole and are debated through the chapters as the critical starting point. However, Bhabha's entire discussion of hybridity and consequently ambivalence rest on the dismissal of an idea of purity in relation to nation and culture and the adoption and celebration of a view of the world that embraces difference, hybridity and liminality.

The idea of authenticity is developed from this perspective in Chapter 6. Following Bhabha it is argued that there is no such thing as 'pure' identity and instead we must understand identity as a mixture of different narratives, cultures, histories and ideologies. The idea of authenticity is important to the Park, and is uncovered throughout the substantive work. There is recourse made regularly to the ideas which contribute to the claims of authenticity, found especially in discussions of the Park's history, buildings and flowerbeds. For the management, the idea is used to invoke ideas of splendour and preservation, as something that can be reclaimed and presented in a manner that demands appreciation and positions the Park in a wider historic meaning. The historic meaning that it is positioned in is not very important for the management; instead it is based on

aesthetic considerations and the use of claims as to when the Park was at its 'best' in terms of management, organisation and, again, aesthetic.

An important example of this approach in and to the Park is the now removed statue of Lord Gough. For the management there is a desire to return the statue, as it was present in the 'original', 'authentic' Park of the late 1800s. There are no political or historical arguments to be considered in this belief-system; it holds that because the statue holds cultural relevance and historical accuracy it should be returned to its prominent position on Chesterfield Avenue. The argument that it provided a meeting spot for people and a central location that could be easily identified is also invoked. However, for some visitors to the Park the statue represented something else. Its meaning was politically loaded; however it was not necessarily associated with the English rule or army that Gough could be seen as representing. Instead, the reasons for its removal were based on the action that would follow if it were replaced. The statue had been removed following a series of de-headings and attempted explosions by nationalist groups.

As such the meaning associated with it must be understood as contested and disputed; essentially it means different things to different people. The understandings of this statue is multiple; for some interviewed it represented the Park when it was in its heyday, and should be returned to preserve the beauty associated with it. For others, the statue represents something more ominous, a memory of violence either through the acts of the British in Ireland or the violence of the reaction against the statue. Either way, according to these understanding surrounding the statue, it is not meant to be in the Park. The discourses stand in opposition to each other, and are rooted in different beliefs about what is important in the Park, and what the space means. However, the coming together of these discourses in the space makes the statue an interesting example to illustrate the manner in which the contested meanings based in different encodings and recordings exist within the Park (Hall, 1980). Culturally, for many younger people, the statue does not figure at all in the understanding of the space and yet, for some it is an important and meaningful issue.

This thesis presents and collaborates through substantial work the idea that authenticity, in a postmodern, postcolonial world, reverts to the reproduction of origins and its values that perpetuate ideas associated with both the coloniser and also with ideas of a nationality removed from this history. Following Adorno, the authentic was discussed as something that emerges because it's been socialised and popularised. The empirical work on the Park problematises this idea that there is one 'reading' of history that is most accepted and therefore socially accepted by highlighting that there are always many different readings, and therefore claims to authenticity. However, there is an official authenticity that becomes more evident and accessible because of the resources behind its promotion. The official idea of the authentic is evoked through the Park, and is accepted in the Park's Visitor Centre, promotional material and publicity as being a statement of the authentic Park, a nod to the specifically chosen history and a statement of the values associated with it. It has even begun to be, as Graham (2001) suggests in relation to authenticity in Ireland, a marketable sign of value; the Park sells itself on these reproductions. It is marketed as a historic, 'royal' deer park, and is demonstrative of the values associated with this sort of park; imposition of control, power of culture over nature and austerity in the maintenance of standards.

So how does the colonial history figure in this? It is continually exerting influence, it is impossible to escape from it; the buildings are from this period, the planting and lighting and railings all remind us of the period and the marketed authenticity of the Park is based within the epoch as well. But in what way is this developed culturally? While the past is being reproduced, it is also being filtered and reconstituted and this can be uncovered in the way the Park is understood and managed. While there are values associated with the colonisers present in the Park; as detailed above, there is also a counter-understanding of the Park's space. There is more happening than a dialectical adoption of the coloniser's authenticity by the colonised in an attempt to reproduce the cultural controls imposed on them. More even has emerged than the colonised adopting the values and controls of the colonised in an attempt to achieve that which they have or in an attempt to emulate their culture. Instead, as Graham (2001) notes, because of the close proximity of the two islands, the similarity racially and

ethnically of the people, there are more complex systems at work. The Park, 'bigger than all London's put together', has taken on these values, the values that are associated with its origins and transformed into something else. There are cultural signifiers that exist beyond the culture of the colonised; the Papal visit, the Knockmaree burial mound, the Eucharistic Visit, the President's residence with the candle burning to bring the diaspora home safely and the use of the Park that the people of Dublin and Ireland employ. These things, and many more, change the values of the Park; the claim to an authenticity from the colonial period is still used to evoke some values, but the narratives that constitute the Park move it away from the historic focus that it maintains and distorts and liberates another version of understanding; another way of becoming in the Park (Deleuze, 2004).

To offer a broader discussion on what this means for postcolonialism and authenticity, it would need to be understood in the specific relations between Ireland and the UK. Preceding and following the actual colonising project that began in Ireland in the 1600s, the 'evaluation ethic' was evoked to justify the colonisation project. This meant that the Irish were described and constructed as being inferior to the colonialists culture, intellect and material and technical achievements, and were therefore worthy subjects of colonisation. In this instance, the population became the objects of the colonial discourse, they were to be acted upon by this power and control and constituted accordingly. However, this was never truly the case, and as time progressed it became evident that they were more active subjects in this relationship. Power was not simply exerted upon them; it was a complex system in which there were points of confrontation, and outright rejection. In a similar sense, the colonisers were not unaffected by the interactions. The result was that there were no pure ideals or cultures to have recourse made to their authenticity; instead there was an amalgamation of ideas and values in a manner which produced a multi-cultural, diverse society. There were remaining power structures that mediated this relationship but these came to be understood and assimilated in various different ways through time, and the very act of being by everyone altered accordingly. As suggested in the Park, people do understand the history in different ways; for some the Gough statue represents an important historic monument in the Park

and should be returned for that reason and for others he represents all that is bad in the interaction between the two countries. Other people are probably unaware of his previous presence at the roundabout, and understand the roundabout in entirely different ways. The roundabout is now the site of the Christmas tree, and this was discussed as something attractive about the Park during this time of year. In the same way as the Pope's visit held different memories for different people, depending on faith, participation, organisation and the demise of the Catholic Church, the different things that have been found on the roundabout hold different meanings for people too. As such we should understand the meaning assigned to the different adornments to the roundabout as a complicated and shifting matrix of control, dominance and resistance.

This section of the conclusion has highlighted the position allocated to ideas of authenticity in Phoenix Park. Moving beyond the Park boundaries, it has made suggestions about what this means for a postcolonial idea of authenticity. To expand this, the idea of nation can be evoked. Nations are 'imagined political communities' (Anderson, 1983) that call on shared signs and symbols to suggest a common experience to the members of the community. In the Park, we can see shared experiences and common signs used to suggest ideas of community and communal understanding. However, attempts to make recourse to ideas of an authentic, pure origin of nations cannot be claimed and must be continually problematised, instead recognising that all cultural identity is produced in contradictory and ambivalent spaces. As such, any description of a country as multicultural is again problematic; all cultures are multiple constructs that are continually influenced and developed through interaction between global flows of information, knowledge and culture. This does not diminish the influence of a colonial history, it is important to recognise the historical influence this exerts. This does not mean that it should be privileged above other influences only that this is the specific focus of this thesis. As a thesis may focus on class or gender as the key theme of the inquiry, it does not mean that there are no other factors which exert influence only that that is the chosen focus.

2.2 Nationalism and Irishness

The above discussion of authenticity leads to the next theme that emerged as significant for this thesis, ideas of nation, nationalism and Irishness. The theory associated with this is discussed in Chapter 2, and developed in the empirical Chapter 7 and the Chapter 8. The idea that Ireland was 'invented' by different groups: the English, the Irish themselves and the Irish diaspora, was discussed in relation to the Park and used to examine the ideas of nation that were forwarded in the literature review. This conclusion will examine the idea of Irish identity in relation to the global processes of modernity that Giddens (1990) brings to our attention; the position that Ireland occupies as a European nation and a world state.

On July 10th, 2006 the Bank of Ireland published a report which positioned Ireland second richest in a survey of the top eight leading OECD nation. Falling behind only Japan, Ireland's growth in wealth per head (which averages at Euro 150,000 wealth per head) is accredited to entrepreneurial activity and high risk orientated behaviour than other countries, where inheritance feature more prominently. The wealth has been created through gains in property investment and through a willingness to borrow and to invest further. The vast bulk of this wealth has been created in the past ten years, and so is first generational by nature. This study does not stand-alone; in 2005 the UN Human Development Report found Ireland to be the second wealthiest country in the world. So how has, as one website (O'Reilly, 2005) succinctly puts it, 'the country that for hundreds of years was best known for emigration, tragic poets, famines, civil wars and leprechauns today [got] a per capita G.D.P. higher than that of Germany, France and Britain' adapted to the change, and has it encroached on an idea of Irishness? Well, for one thing, the statistics are misleading; Ireland may have had a massive growth in net wealth over the last ten years, and the average wealth per head may signify important changes, but Ireland is also one of the more unequal countries in the 2005 report. It also had the 3rd highest level of poverty in the eighteen industrial countries surveyed; though any discussion of poverty must be understood as relative and not absolute.

The first thing to consider in these reports is the important role that membership of the EU has on Ireland's increased wealth. As the Taoiseach, Bertie Ahern summed up following the publication of the report by the Bank of Ireland,

'A turning point for the Irish economy was our accession to the EU in 1973. EU membership has underpinned our economic development. It means we are actively involved in discussions and decision-making, at the European level, on issues that fundamentally affect our interests and our future. It provides access to the Single European Market. It has brought generous financial support from our EU partners through regional development, cohesion and social funds. It has supported the development of a vibrant rural economy. It has provided political and financial support for conflict resolution in Northern Ireland.'

[...]

'In Ireland's case, the EU provided financial support for national development plans elaborated by the Government with inputs from civil society. This support amounted to 1.5% of GDP in the years 1989 to 2000. The implementation of these plans, and the effective use of the EU resources, required good governance, strong public expenditure management and an effective public sector. The funds Ireland received ultimately came from the taxpayers in other EU Member States. They were channelled to Ireland through one single institution, the European Commission.'

(www.finance.gov.ie)

So, European influence was great in the development of the Irish economy and cannot be underestimated in any account of the development of the Celtic Tiger economy and subsequent continued growth in wealth. Ireland has benefited greatly from the financial support of the EU, gaining significant growth in GDP as a result. However, this has provided Ireland with a secure base on which to now grow and has allowed Ireland the financial stability to warrant the risk orientated behaviour that has increased Irish wealth in the last few years. From this we can see that Said's (2000) contention that all nationalism develops from a condition of estrangement would seem to be problematic in contemporary Ireland, as the importance and influence of the financial aspects of the European Union have bred feelings of unity and union. This has influenced Irish identity in an important way and feelings of being European are prominent in an Ireland where there have been palpable, material consequences of membership of the Union. If nations are the 'imagined political community' of Anderson (1983) then Ireland imagines itself as a nation with strong links to Europe. It may occupy a Celtic fringe, but Ireland has positioned itself firmly within the centre

of the EU. However, it was not always like this, and Ireland has had a troubled growth towards this commonly held European identity.

The conclusion that this thesis draws on the issue of whether Ireland can be better understood as European or postcolonial, is informed by Kiberd (1997) who draws on the discourses surrounding the ideal of a European, liberal Ireland, free of its problematic past as never achieved due to the 'persistent injustices of Northern Ireland, and the economic underdevelopment of the south [in the 1950s]' (Kiberd, 1997: 93). This meant that the conditions for transcendence away from this past were never propitious; the issues that pulled the nascent state away from the post-imperial European, drew it closer to a much wider global network. However as time progressed away from 1916, and following its position of neutrality in World War 2, Ireland began to move towards a more European idea of itself, and in 1972 Ireland joined the European Economic Community with a majority of two-to-one. In the 1980s, Ireland's economy was under considerable stress. There was a decline in the traditional Irish industry which coincided with EEC membership; there was chronic indebtedness of the State and by 1987 Ireland owed more per capita than either Mexicans or Brazilians and all personal tax went on servicing the interest components of the nationalist dept (Kiberd, 1997). This prompted people to ask if Ireland was more closely aligned with 'Third World countries' rather than European or even developed countries. A columnist in *The Irish Times* in 1987 listed the features that made it at least a question that it was possible to ask, and a pundit in the *Daily Telegraph* in Britain joked that it was only the weather that kept Ireland out of the Third World (Kiberd, 1997). This wasn't quite true; Ireland had a far higher per capita income than, say, India or Argentina at the time, and the country was listed as one of the top twenty-five economic democracies in the world (Kiberd, 1997). However, this prompted an Ireland that was faced with two distinct identity claims; Ireland as the country with the best-educated workforce on the continent (claimed by the Irish Industrial Development Authority) or a subordinate country, attempting to cash in on an image of idyllic green bliss and a slower way of life. These tensions still exist today, and there is a split between commentators who see Ireland as European and modernising, secular, pragmatic and free of old-fashioned national pieties, and then there are

another group who adopt a more postcolonial reading and understand Ireland as a product of its history that must be understood as such. These two groups represent distinct readings of Irish life, but there is a middle ground that must be understood: a forward-looking European country that still understands the past and recognises the importance that a historical grounding provides. As Kiberd says,

‘the real challenge today is to find a truly contrapuntal narrative which projects both aspects of the national experience and captures the complexity of being at once postcolonial and European, an experience which is not in fact unique now that the European Union has received applications for membership from the recently-liberated nations of Eastern Europe. If the decisive relationship in the next century [this century], as the Brandt Commission has stated, will be that between North and South, there is a sense in which that relationship is enacted every day on the streets and in the valleys of Ireland’.

(Kiberd, 1997: 97)

So what does this mean in relation to the Park, and the claims made in this thesis that it represents a liminal, postcolonial space? As previously discussed, Bhabha (1994) contends that all cultural identity is produced in a contradictory, ambivalent space. He proposes this in relation to the ‘conceptual ambivalence’ that underlies the nation. This ambivalence is a product of the two contradictory modes of representation occurring in the nation; the pedagogic and the performative. The pedagogic aspect of this discourse, where the people are the objects of nationalist discourse, works on the idea of a shared, unified collective past in which the people are brought together through some pre-existing underlying bond. The performative relates to the continual re-emphasising and re-demonstrating the signs and symbols of national identity, where the people act as the subject of the national discourse.

Within a global context this seems to take on a different duality; there is a reference to a unity, but an attempt is made to position this unity on a different level, a European level. There is a continual ambivalence between what it means to be European, does it mean negating the national identity claims that may be made and adopting a European identity, but what does that mean? Can it be translated into language applicable to contemporary understandings of identity? These are questions that demand further enquiry, and the adoption of some

aspects of postcolonial theory can help in addressing these issues and understanding the problems associated with answering them.

What this section makes explicit is the necessity to position thinking within a European and global context and not be confined to thinking about it at a national or local level. Ideas of national identity do not occur in a vacuum; this conclusion has hinted at one of the other major influences that exert control over the way identity is conceived of in Ireland. This thesis has held as its focus the local level, a level that is often overlooked in appraising ideas of the national, and as such has aimed to develop an idea of what identity means when looked at from that perspective. The interaction between ideas of the local, the national and the international are complex, and to focus on just one allows a more thorough understanding of the different power relations that are exerting influence over that sphere. In addition, there are methodological issues associated with people's understanding of their position in relation to more abstract ideas of national identity and global positioning that are often exacerbated by interviewing techniques which privilege them. By adopting the methodological stance that focused on being and acting 'in media res' it meant that this thesis allowed the participants to lead the interview and that what was important to them emerged as significant. In addition, the spatial focus meant that it was important to focus on the defined, preset parameters of the research project.

2.3 Space and Place

The spatial practices that help constitute identity are important for this thesis; indeed they constitute one of the most important themes of an amalgamation between ideas of space and place and postcolonial identity. The space that this thesis is positioned in is far wider than the walled boundaries of Phoenix Park; instead the work has moved into an area that privileges the politics of location; a space where those of us who would participate in the formation of counter-hegemonic cultural practices move into; a space, as bell hooks (1990) depicts as a space of radical openness, a margin, a profound edge. For hooks, this politics of location concentrates on the de-colonising role of the African-American intellectual in the 'search for wider spheres of participation in the "world of the

everyday" and in the enablement of radical social action everywhere in the world, from the personal to the planetary' (Soja, 1996: 85). The cultural politics of difference that aim to de-establish and break up the monolithic and homogenous in the name of diversity, multiplicity and heterogeneity redefine ideas of representation and the way it highlights issues like extremism, empire, class, race, sexual orientation, age, nation, nature and region (West, 1990: 20). The decentred subject that characterises this form of political move is based on a space where ties are severed or it can provide the occasion for new and varied forms of bonding. This new bonding can occur in a variety of ways and breaks from the limitations that have confined political action in the past, it also has altered the way that we can contemplate ideas of nationality. The 'imagined communities' that once made up ideas of nation, with recourse to ideas of majority position are now dissolving as ties and bonds are based on weak links rather than the stronger ones of the past.

The idea of an entanglement of power (Sharp et al, 2000) provides a useful metaphor to continue the discussion of space, spatial practices and the relationship between such practices and the sites wherein they are articulated. This relationship is mutually constitutive, albeit in different ways in different sites, and there is a strong need to ground inquiries into more substantive enquiry in order to observe the various processes of domination and resistance that are occurring within. As Foucault (1986) says, space is where discourses of power and knowledge are transformed into actual relations of power. The idea of entanglement evokes metaphorical images of knotted threads and tangles, images which show the deep spatiality of the coming together that this entails. Power has positive and negative dimensions, something Foucault directed our attention to continually; it can be regressive and progressive, constraining and facilitative, to be condemned and to be celebrated. The spatialised threads along and through which power circulates, entering into the world of individuals and groups as they are simultaneously undergoing and exercising this power.

As Smith recognises, 'People work in a variety of connected, sometimes contradictory, often complex ways with a range of definitions of how [...] transition is [...] implemented. In this the geographies which people construct,

perform and contest have powerful outcomes' (Smith, 2000: 143). The different people interviewed in Phoenix Park occupy these different positions in regard to change, and this section is going to develop the idea of the geographies that people construct, perform and contest and the relation that it has to the cultural understanding of the Park and the position it occupies in discourses of postcolonialism. Following Massey (2000), this thesis recognises that there are relationships between different people, groups, places, spaces and which produce a politics of interrelation (Massey, 2000: 284), a politics which

'rather than claiming rights for a rapidly multiplying set of identities, concerns itself more with challenging, and taking responsibility for, the form of the relationships through which those identities are constructed, in which we are individually and collectively positioned and through which society more broadly is constituted'

(Massey, 2000: 284)

So the relationships that people hold and which produce identities are dynamic practices, processes that change and adapt to different settings and situations. Also then, the spaces of domination and resistance are active spaces of action, continually being made. These are spaces that are continually formed out of practices, meaning that if we refuse in any simplistic way to counterpose domination and resistance in the confines of a dualistic, binary then we must also reject any simplistic spatial imagery of centre and margin, and instead must embrace the complexity and 'entanglement' of spatial and cultural threads. The identities of those positioned within the different entanglements, which exist all over the Park and around it in the history, policies and public imagination, are themselves constituted through the practice of interrelation. This idea of entanglements is a useful way of engaging with the idea of the margin, or the liminal. This is a place where there are possibilities associated with hybridity and the breaking down of binaries, and also is a reaction against ideas of centre/periphery. Epistemologically the liminal represents a thirdspace, a way of moving beyond constricting binaries and reductionary dualisms.

However, the word entanglements allows movement away from an over romanticising of the margins; we don't occupy the margins at all times; in fact as an academic the position occupied is one of relative privilege and powerfulness on at least some of the axes of social relations within which we are positioned

and constructed. As Massey (2000) discusses, what is at issue politically is not so much where the spaces are (centre or margin) but what kinds of spaces they are: what kinds of spatialities of power do we want to build? Returning to the substantive chapters, an interesting example of this idea of entanglements and spatially constructed identities comes from the Chief Superintendents discussion of the history of the Park. He describes the Park as dangerous, dark and swampy before the time of his hero, Decimus Burton, and uses this to invoke ideas of a space that was untouched by modernity, a wilderness that didn't represent anything good. This is closely aligned to colonial ideas which used concepts such as *terra nullus* to justify colonising the land and people. However, retaining the Park to the layout of Burton has now become an act of resistance, resistance to change and the constant demands of modernity. The Chief Superintendent has embraced modernity to an extent, but has not developed the Park to conform to contemporary ideas of modernity. In this example we can see how the Park represents an entanglement of different ideas of power, resistance and dominance. There are ghosts of the colonial era still exerting some power, but they are only ghosts and it is only the memories of things that have passed which are acting in this way.

Following Durkheim (1895), history is not dead but is a social force present in what is remembered and acted on by the living. The power structures associated with colonialism are no longer present; people are negotiating the different discourses that remain in different ways; negotiating different identities and positions within and in relation to the historical remnants that exist. In the case of the Chief Superintendent, and this specific example, he embraces the structure of the Park that comes from a certain era, invoking colonial type justification for the original redevelopment of the Park, and continuing these into the contemporary world and using similar sorts of arguments to justify it now. However, he is resistant to change that is presented to him using the same arguments; the advent of modernity, the need for change and the adaptation of aesthetic considerations to be more practical. The resistance to allowing buses through the Park can be understood using this reading, though there are other

ways through which that decision can be read³³. The need for all the buildings to be uniform and based on a certain point in time, the point in time that the Chief Superintendent has identified, is also linked to this rational. Drawing on the Saidian idea of cartographic impulse, a desire to reclaim land and territory that extends beyond a transfer of titles and deeds into the realm of representation, metaphor and cultural identity, it is possible then to uncover the identity politics that occur through the Park and allow claims to be made to ideas of Irish identity, or contingent, more local identities that draw on different aspects of the history of the Park (for example, the cross cut into the ground).

2.4 Liminality and Thirdspace: A Thirdspace of Enunciation

The idea of liminality is one which has been threaded through this thesis and has proven to be the main theme around which the theory and empirical enquiry has conjugated. The amalgamation of ideas of the spatial, the epistemological and the cultural has resulted into a discernable identification of spaces of enquiry that resist positioning within the binaries of coloniser/ colonised, nature/ culture, history/ present, centre/ periphery and space/ society. This conclusion focuses on the theory of Bhabha (1994, 1996) and the most relevant work around thirdspace to this thesis. It offers a complete overview of the ideas of thirdspace and liminality and the reasons why it is important to this piece of research.

Bhabha developed the connected ideas of liminality, hybridity and third space as a means of describing the construction of culture and identity within conditions of colonial antagonism and inequity (Bhabha, 1994; 1996). The idea of hybridity has a history that posits its use as problematic, even offensive due to the place it held in colonial discourse as an offensive, abusive term for ‘mixed breeds’. For Young (1995) ‘it is imbued in nineteenth century eugenicist and scientific-racist thought’, but this has been inverted in its postcolonial use, the meaning has been contested and repossessed, and it is now taken to signify a privileged position, celebrated as a kind of superior cultural intelligence. In postcolonial discourse, the idea that any culture or identity is pure or essential is disputable (Ashcroft et al, 2003), with some commentators extending this to ‘all forms of culture are

³³ It can also be read as trying to protect the Park from ‘too many’ public or the ‘wrong sort’ of person, as the Superintendent discussed.

continually in a process of hybridity' (Rutherford, 1990: 211). This moves the idea of national culture and identity into a space where it is open to criticism and new readings are not only possible but crucial. The new mutation replaces the established pattern with a 'mutual and mutable' (Bhabha, 1994) representation of cultural difference that is positioned in between the coloniser/ colonised. For Bhabha it is the indeterminate spaces in-between subject-positions that are lauded as the locale of the disruption and displacement of hegemonic colonial narratives of cultural structures and practices (Bhabha, 1994, 1996). He posits hybridity as such a form of liminal or in-between space, where the 'cutting edge of translation and negotiation' (Bhabha, 1996) occurs and which he terms the thirdspace.

Thirdspace is a space intrinsically critical of essentialist positions of identity and a conceptualisation of original or originary culture, and is a space where new forms of identity are realised (as discussed in the Chapter 8). This is the 'fifth province' of Ireland that Field Day (discussed in Chapter 1 and 2) put forward, a new, undetermined and free, space in which movement can occur and change is facilitated. As Rutherford (1990: 211) describes, 'For me the importance of hybridity is not to be able to trace two original moments from which the third emerges, rather hybridity to me is the "thirdspace" which enables other positions to emerge'. Thus, thirdspace is a mode of articulation, a way of describing a productive and not merely reflective space that engenders new possibilities. It is an 'interruptive, interrogative and enunciative' (Bhabha, 1994) space of new forms of cultural meaning, production blurring the limitations of existing boundaries and calling into question established categories of culture and identity. The hybrid thirdspace is an ambivalent site where cultural meaning and representation have no 'primordial unity or fixity' (Bhabha, 1994), a space where the Deleuzian notions of the ontological primacy of becoming are effectively played out.

The concept of thirdspace is submitted as useful for analysing the enunciation, transgression and subversion of dualistic categories going beyond the realm of colonial binary thinking and oppositional positioning (Law, 1997). Despite the exposure of the thirdspace to contradictions and ambiguities, it provides a spatial

politics of inclusion rather than exclusion that ‘initiates new signs of identity and innovative sites of collaboration and contestation’ (Bhabha, 1994: 1). And it is this that the thesis has identified in Phoenix Park, from the more obvious examples of it within the Visitor Centre, to the linked themes in the interviews with the management and the visitors to the Park. There is a continual collaboration with the history of the Park with those who visit, those who work there, and the constituted space is in continual dialogue with its own past. This is linked with a contestation, the development of a new understanding of the place, a new reading of the cultural signifiers and important events. It is a site for enunciation, transgression and subversion of the simple reading of colonial past and Irish present, it is an argument for the recognition of the complex, entangled relationships that are occurring and the specific, contingent cultural manifestations that this is producing. It posits that ideas of national identity must be understood as hybrid products of interaction with a myriad of different powers, forces, historical and social, and understandings. As the section on national identity in this conclusion identifies, Ireland has had a complex relationship not only with its colonial neighbours, but also with all of Europe.

3. Conclusion - Postcolonialism and Sociology

The main aim of this thesis has been to demonstrate that postcolonial theory provides a reliable and informative epistemological position to inform research. The application of substantive research to the more theoretical spaces occupied by postcolonial theory has developed a more detailed understanding of the Phoenix Park and also of the theory that is being used. This position exhibits awareness of the criticism that has been targeted at specifically Bhabha’s conceptual model, criticism relating to the inaccessibility of his work, and the perceived neglect to adequately conceptualise the historical-material conditions that would emerge within a colonial discourse framework (Parry, 1996; Mitchell, 1997). The thesis has not been positioned within a political and cultural vacuum, and has had sustained recourse to these historical and material conditions that have shaped the Park and continue to exert influence. Indeed, this is one of the major strengths of this work; the discussion of theory that was not previously based on substantive work has been changed to the development of the theory through substantive, empirical enquiry. Sociological enquiry rests on the idea of

developing understandings of the way society works; the interactions that construct it, the power relations that occur between different groups, individuals or established institutions, and the way in which we continue to understand groups and the way people gravitate towards them.

This thesis has developed ideas around identity work, and the way space and history converge to form disparate identities and cultural understandings around history and place. The work has produced a number of connections (Strathern, 1991), between the space and theory, between the data and ideas. These connections have allowed the evocation of the research object, postcolonialism through the development of these different connections and allowed ideas around the main themes to develop and emerge. This conclusion had already invoked the idea of a sociological imagination (Mills, 1967) to explain how the thesis engaged with different ideas and developed ideas of society; understood as the connection between individual experience and societal understanding in a matrix of history, biography and, what Mills (1967) calls social structure and what this thesis has developed into rhizomatic power structures based on historical and cultural influences. By locating the work within the biography of the researcher, dealt with explicitly in Chapter 4, it is hoped that this thesis has allowed insight and understanding of what a postcolonial space looks like, and why it is of contemporary importance to understand it as such.

Afterthought

The idea of connections (Strathern, 1991) is used in ethnography to develop a way of interacting with the research site, theory and praxis, and is a useful starting point for this Afterthought. This thesis allowed me to develop a number of connections; between the research site and the theory; between the data and my ideas; between different theoretical areas; and between different modes of understanding. These connections have been the main aim of the work, I have not wanted to make any conclusions relating to the wider implications of this work; instead I have been ‘adding without the equals sign’ (Hetherington, 1998) and developing the links between different theoretical works, methods and approaches to understanding space, place, culture and identity.

In retrospect there are some things I would have done differently in this piece of work; and it is in these areas that I feel I have developed the most as a result. Theoretically the work of Deleuze and Guattari could have been brought more into the analysis; and this is a direction I want to move in with the data. The concepts are scattered through the text, the fold, rhizomatic, lines of flight, but they are not engaged with to the highest level they could be; this is something I wish to develop. Methodologically, it was difficult to arrange interviews with different people in the Park, especially the Rangers and Guides. The travel from Wales to Ireland meant that it was difficult to be spontaneous, though when I was in Dublin this was possible, and so there were occasions when I would receive notification of availability for an interview when I was in the wrong country. However, the advantage of distance must also be asserted here; it was useful to move away from the Park and Ireland for periods of writing, allowing a ‘critical distance’ and space to reflect.

The PhD has been a process of learning, developing and reflecting. My theoretical position and understanding of what this means has emerged through the writing process, and true to the subject I was writing about, I now understand it as multiple and fragmented. At the beginning of the work I thought I was looking for answers; but in fact, this process has taught me that the focus should always be on questions.

Bibliography

- Abercrombie, P. (1941). "Dublin Sketch Development Plan." http://www.irish-architecture.com/buildings_ireland/dublin/city_development/abercrombie_1941/ Retrieved 9th March, 2005.
- Adorno, T. (1973 [1964]). The Jargon of Authenticity. London, Routledge and Kegan Paul.
- Ahluwalia, P. (2005). "Out of Africa: post-structuralism's colonial roots." Postcolonial Studies 8(2): 137 - 154.
- Ali, T. (2003). "Remembering Edward Said." New Left Review 24(November-December 2004).
- Allen, R. (2004). No Global: The People of Ireland vs the Multinationals. London, Pluto Press.
- Anderson, B. (1983, 1991). Imagined Communities: Reflections on the Origins and Spread of Nationalism. London, Verso.
- Anderson, J. (2002). "Researching environmental resistance: working through Secondspace and Thirdspace approaches." Qualitative Research 2(3): 301- 321.
- Anderson, J. (2004). "Talking whilst walking: a geographical archaeology of knowledge. ." Area 36: 245-261.
- Anderson, K. (1995). "Culture and nature at the Adelaide Zoo: at the frontiers of 'human' geography." Transactions Institute of British Geographers 20(New Series): 275-94.
- Arnold, D. (1996). The Problem of Nature: environment, culture and European expansion. Oxford, Blackwell.
- Arrowsmith, A. (2003). "Fantasy Ireland: The Figure of the Returnee in Irish Culture." Moving Worlds: A Journal of Transcultural Writings 3(1): 101 -114.
- Ashcroft, B., G. Griffiths, et al. (2003). Post-Colonial Studies: The Key Concepts. London, Routledge.
- Atkinson, D. (2000). Nomadic Strategies and Colonial Governance: Domination and resistance in Cyrenaica, 1923 - 1932. entanglements of power: geographies of domination/ resistance. J. Sharp, P. Routledge, C. Philo and R. Paddison.

London. Routledge.

Balibar, E., Ed. (1991). Racism and Nationalism. Race, Nationalism and Class. London, Verso.

Ball, F. E. (1902). A History of the County Dublin. The people, parishes and antiquities from the earliest times to the close of the Nineteenth Century.

Ball, R. (1997). Drug Abuse leads to sex and violence in Phoenix Park. Irish Times. Dublin.

Barfield, T., Ed. (2001). The Dictionary of Anthropology. London, Blackwell.

Barry, F. (2006). Politics, Institutions and Post-War Economic Growth in Ireland. International Economic History Congress Helsinki.

Bateson, M. C. and G. Bateson, Eds. (2000). Steps to an Ecology of Mind: Collected Essays in Anthropology, Psychiatry, Evolution and Epistemology. Chicago, University of Chicago Press.

Baudrillard, J. (1983). Simulations. New York, Semiotext(e).

Baudrillard, J. (1994). Simulacra and Simulation (The Body in Theory: Histories of Cultural Materialism). Michigan, University of Michigan Press.

Bauman, Z. (1987). Legislators and Interpreters. Cambridge, Polity.

Bauman, Z. (1997). Postmodernity and its Discontents. Cambridge, Polity.

Berger, P. L. and T. Luckmann (1967). The Social Construction of Reality. New York, Doubleday.

Berman, M. (1982). All That is Solid Melts into Air: The Experience of Modernity. London, Penguin.

Bhabha, H. (2002). www.heliotrope.net.au/mordwen/articles/bhabha/htm Retrieved 23rd April, 2005.

Bhabha, H. K. (1987). "'What does the Black Man Want?'" New Formations No. 1(Spring): 118 - 131.

Bhabha, H. K. (1991). 'Calibran Speaks to Prospero': Cultural identity and the Crisis of Representation. Critical Fictions: the Politics of Imaginative Writing. P. Marini. Seattle, Bay Press: 62 - 5.

Bhabha, H. K. (1992). Postcolonial authority and postcolonial guilt. Cultural Studies. L. Grossberg, C. Neilson and P. Treichler. New York Routledge.

- Bhabha, H. K. (1994). The Location of Culture. London, Routledge.
- Bhabha, H. K. (1996). Cultures in Between. Questions of Cultural Identity. S. Hall and P. Du Gay. London, Sage Publications.
- Bhabha, H. K. (2003). "Democracy De-realized." Diogenes 50(1): 27 - 35.
- Black, J. (2005). "It happened in the Phoenix Park all in the month of May " www.indymedia.ie/article/69521 Retrieved 3rd January, 2005.
- Bloor, M. J., Barnard, M. A., Finlay, A. and McKeganey N. P. (1993). "HIV-Related Risk Practices Among Glasgow Male Prostitutes." Medical Anthropology Quarterly 7((2)): 152 - 169.
- Blunt, A. and C. McEwan, Eds. (2002). Postcolonial Geographies. London, Continuum.
- Boyce Davis, C. (1994). Black Women, Writing and Identity: Migrations of the Subject. London and New York, Routledge.
- Boylan, T. A. and A. Foley, Eds. (1992). Political Economy and Colonial Ireland: The Propagation and Ideological Function of Economic Discourse in the Nineteenth Century. Routledge.
- Bradbury, M. a. M., J. (1991). Modernism 1890 - 1930. London, Penguin.
- Brennan, T. (1990). The National Longing for Form. Nation and Narrative. H. K. Bhabha. London, Routledge: 44-70.
- Butler-Cullingford, E. (2001). Ireland's Others: Gender and Ethnicity in Irish Literature. Irish Literature and Popular Culture. C. C. F. D. Monographs. Cork, Cork University Press.
- Cairns, D. and S. Richards (1988). Writing Ireland: Colonialism, Nationalism and Culture. Manchester, Manchester University Press.
- Calhoun, C. (1997). Nationalism. Buckingham, Open University Press.
- Carroll, C. (2003). Introduction: The Nation and Postcolonial Theory. Ireland and Postcolonial Theory. C. Carroll and P. King. Cork, Cork University Press: 1 - 16.
- Casey, E. (2001). "Between geography and philosophy: what does it mean to be in the place-world?" Annals of the Association of American Geographers 91: 683 - 93.
- Chambers, I. and L. Curti, Eds. (1996). The Post-colonial question: common skies divided horizons. London, Routledge.
- Chart, D. A. (1907). "The Story of Dublin." www.chapter.eiretek.org Retrieved 19th

May, 2005.

- Chatterjee, P. (1986). Nationalist thought and the Colonial World: A Derivative Discourse. University of Minnesota Press.
- Chesters, G. and I. Welsh (2006). Complexity and Social Movements: Protest at the Edge of Chaos London, Routledge.
- Childs, P. a. W., Patrick (1996). An Introduction to Post-Colonial Theory.
- Cicourel, A. V. (1974). Theory and Method in a Study of Argentine Fertility. New York, Wiley.
- Cleary, C. (2006). Park People. The Irish Times Dublin: 16 - 18.
- Cleary, J. (2003). 'Misplaced Ideas?': Colonialism, Location and Dislocation in Irish Studies. Ireland and Postcolonial Theory. C. Carroll and P. King. Cork, Cork Universtiy Press: 16 -46.
- Clifford, J. (1988). Predicament of Culture: Twentieth Century Ethnography, Literature and Art. London, Harvard University Press.
- Coffey, A., Atkinson, P. (1996). Making Sense of Qualitative Data. London, Sage.
- Connolly, C. (2001). "Theorising Ireland." Irish Studies Review 9(1): 301 - 315.
- Connolly, C. (2003). The Turn to the Map: Cartographic Fictions in Irish Culture. Eire/LAnd. V. Kreilkamp. Chicago, University of Chicago: 27 - 41.
- Connolly, L. (2004). "The Limits of 'Irish Studies': Historicism, Culturalism, Paternalism." Irish Studies Review 12(2): 140 - 162.
- Coogan, T. P. (1996). Eamon De Valera: The Man Who Was Ireland. New York, Harper Perennial.
- Corfe, T. (1968). The Phoenix Park Murders: Conflict, Compromise and Tragedy in Ireland, 1879 - 1882. London, Hodder and Stoughton.
- Cosgrave, D. (1909). "North Dublin." www.chapters.eiretek.org Retrieved 23rd May, 2005.
- Cosgrave, D. (1984). Social Formation and symbolic landscape. London, Croom Helm.
- Cosgrave, D. (1989). Geography is everywhere: culture and symbolism in human landscapes. New Horizons in Human Geography. D. Gregory and R. Walford. London, Palgrave Macmillan 118 - 135.
- Costello, J.P. (1963). Dail Eireann, Vol 206, 11 Dec 1963, Committee on Finance.

- Crag, M. and N. Thrift (2000). thinking space. London, Routledge.
- Cranz, G. (1982). The Politics of Parks Design: A History of Urban Parks in America. Cambridge, Mass., MIT Press.
- Curtis, L. P., Jr. (1997). Apes and Angels: The Irishman in Victorian Caricature. Washington and London, Smithsonian Institution Press.
- Davis, K. (1937). "The Sociology of Prostitution." American Sociological Review 2(5): 744 - 755.
- de Blij, H. J. (1996). Geography: Realms, Regions and Concepts. MA, John Wiley and Sons, Inc.
- Deane, S. (1983). Heroic Styles: The Tradition of an Idea. Ireland's Field Day. S. Deane. London, HarperCollins.
- Deane, S. (1990). Nationalism, Colonialism and Literature. Minnesota, University of Minnesota Press.
- Deane, S., Ed. (1991). The Field Day Anthology of Irish Writing. London, Faber and Faber Ltd.
- Deane, S. (2003). Dumbness and Eloquence: A Note on English as We Write It in Ireland. Ireland and Postcolonial Theory. C. Carroll and P. King. Cork, Cork University Press: 109 - 122.
- Deleuze, G. (1992). The Fold: Leibnez and the Baroque. London, Continuum International Publishing Group Ltd.
- Deleuze, G. and F. Guattari (2004). A thousand plateaus : capitalism and schizophrenia. London Continuum.
- Denzin, N. K. (1997). Interpretive Ethnography Ethnographic Practices for the 21st Century. London, Sage Publications Ltd.
- Denzin, N. K. and Y. S. Lincoln (2000). Handbook of Qualitative Research. Thousand Oaks CA, Sage.
- Dorrian, M. (2001). "On Some Spatial Aspects of the Colonial Discourse on Ireland." The Journal of Architecture 6((1) Spring).
- Doyle, D. (2002). "Doyle Home Page."
http://www.doyle.com.au/irish_soldiers_of_the_british_ar.htm Retrieved 5th April, 2006.

- Dubow, J. (2000). "'From a View *on* the World to a point of view *in* it' Rethinking Sight, Space and the Colonial Subject." interventions 2(1): 87 - 102.
- Durkheim, E. (1895, 1982). Rules of Sociological Method, The Free Press.
- Eagleton, T. (1995). Heathcliff and the Great Hunger: Studies in Irish Culture. London, Verso.
- Eagleton, T. (1999). "In the Gaudy Supermarket." London Review of Books 21(10).
- Eagleton, T. (2004). After Theory. London, Penguin Books Ltd.
- Fagan, J. (2004). EUR110m in sales of Phoenix Park homes. The Irish Times. Dublin.
- Fanon, F. (1952). Black Skin, White Masks. London, Pluto Press.
- Fanon, F. (1961). The Wretched of the Earth. London, Penguin Books.
- Fanon, F. (1965). A Dying Colonialism. New York, Grove press.
- Fardon, R. (1990). Localizing strategies : regional traditions of ethnographic writing. Edinburgh, Scottish Academic Press.
- Fardon, R., Ed. (1995). Counterworks: Managing the Diversity of Knowledge. London, Routledge.
- Finkelstein, J. (1999). "The place of place in sociology." Postcolonial Studies 2(3): 285 - 287.
- Finkelkraut, A. (1988). The Undoing of Thought. London, The Claridge Press.
- Finlay, A. (1999). "Whatever you say, say nothing, an ethnographic encounter in Northern Ireland and its sequel." Sociological research online 4(3).
- Finlay, A. (2006). "What lies beneath? ." <http://archives.tcm.ie/businesspost/2006/03/05/story12358.asp> Retrieved 4th July, 2005.
- Finlay, L. (2002). "Negotiating the swamp: the opportunity and challenge of reflexivity in research practice." Qualitative Research 2: 209 - 230.
- Fiske, J. (1994). Audiencing: cultural practice and cultural studies. The handbook of qualitative research. N. K. Denzin, Lincoln, Y.S. Thousand Oaks, CA, Sage.
- Fitzpatrick, S. A. O. (1907). "Dublin: A Historical and Topographical Account of the City." www.chapters.eiretek.org Retrieved 25th April, 2005.
- Flick, U. (1998). An Introduction to Qualitative Research. London, Sage.
- Foster, J. W. (1991). Colonial Consequences: Essays in Irish Literature and Culture.

Dublin. Lilliput Press.

Foucault, M. (1984). 'Space, Knowledge and Power'. The Foucault Reader. P. Rabinow. New York, Pantheon: 239 - 56.

Foucault, M. (1986). "Of Other Spaces." Diacritics 16(1): 22 -27.

Foucault, M. (1998). Different Spaces. Aesthetics, Method and Epistemology: Essential Works of Foucault 1954 - 1984. J. D. Faubion. London, The Penguin Press: 175 - 185.

Foucault, M. (2002). The Archaeology of Knowledge. London, Routledge.

Friel, B. (1981). Translations. London, Faber.

Friel, B., K. Andrew, et al. (1983). "Translations and A Paper Landscape: Between Fiction and History." The Crane Bag 7(2): 120 - 122.

Geertz, C. (1973). The Interpretation of Cultures. New York, Basic Books.

Geertz, C. (2000). Available Light: Anthropological Reflections on Philosophical Topics. Woodstock, Oxfordshire, Princeton University Press.

Gellner, E. (1983). Nations and Nationalism. London, Blackwell.

Giddens, A. (1990). The Consequences of Modernity. Cambridge, Polity press.

Gilfoyle, T. J. (1999). "Prostitutes in History: From Parables of Pornography to Metaphors of Modernity." The American Historical Review 104(1): 117 - 141.

Glasser, B. a. S., A. (1967). The discovery of grounded theory. Chicago, Aldine.

Golomb, J. (1995). In Search of Authenticity. London, Routledge.

Graham, C. (1995). "'Liminal Spaces: Post-Colonial Theories and Irish Culture'." Irish Review 16: 29 - 44.

Graham, C. (2001). "'Blame it on Maureen O'Hara': Ireland and the Trope of Authenticity." Cultural Studies 15(1): 58 - 75.

Graham, C. (2001). Deconstructing Ireland Identity, Theory, Culture. Edinburgh, Edinburgh University Press Ltd.

Gregory, D. (2000). Edward Said's Imaginative Geographies. thinking space. M. Crang, Thrift, N. London, Routledge: 302-345.

Griffiths, G. (1994). The Myth of Authenticity: Representation, Discourse and Practice. De-scribing Empire: Postcolonialism and Textuality. C. Tiffin and A. Lawson. London, Routledge.

- Grove, R. (1990). Green Imperialism: colonial expansion, tropical island Edens and the origin of environmentalism, 1600 - 1800. Cambridge, Cambridge University Press.
- Gubrium, J. F. and J. A. Holstein (2000). Analysing Interpretive Practice. Handbook of Qualitative Research. N. K. Denzin and Y. S. Lincoln. London, Sage Publications, Ltd.
- Guha, R. (1988). On Some Aspects of the Historiography of Colonial India. Selected Subaltern Studies. R. Guha and G. C. Spivak. Delhi, Oxford University Press: 37- 44.
- Guha, R. and G. C. Spivak, Eds. (1988). Selected Subaltern Studies. Delhi, Oxford University Press.
- Haddour, A. (2001). Sartre, Colonialism and Neocolonialism. New York, Routledge.
- Halbwachs, M. (1992). On Collective Memory. Chicago, University of Chicago Press.
- Hall, S. (1980). Cultural Studies and the Centre: some problematics and problems. Culture, Media and Language. S. Hall, D. Hobson, A. Lowe and A. Willis. London, Routledge.
- Hansson, H. (2003). Writing the Interspace: Emily Lawless's Geographical Imagination. Engaging Modernity: Readings of Irish politics, Culture and Literature at the Turn of the Century. M. Boss, Maher, Eamon. Dublin, Veritas Publications: 121 - 141.
- Haraway, D. (1983). "Teddy bear patriarchy: taxidermy in the Garden of Eden, New York, 1908 - 1936." Social Text 3: 20 - 64.
- Haraway, D. (1990). Primate Visions: Gender, Race, and Nature in the World of Modern Science London, Routledge.
- Harvey, D. (1986). Consciousness and the Urban Experience. Oxford, Blackwell.
- Harvey, D. (1990). The Condition of Postmodernity. Oxford, Blackwell.
- Hastings, A. (1997). The Construction of Nationhood: Ethnicity, Religion and Nationalism. Cambridge, Cambridge University Press.
- Heaney, S. (1975). North. London, Faber and Faber Ltd.
- Hechter, M. (1975). Internal Colonialism: The Celtic Fringe in British National Development 1536 - 1966. Berkeley, University of California Press.

- Hetherington, K. (1996). "Identity Formation, Space and Social Centrality." Theory, Culture and Society 13(4): 33 - 52.
- Hetherington, K. (1997). Badlands of Modernity. London, Routledge.
- Hetherington, K. (1998). Expressions of Identity Space, Performance, Politics. London, Sage Publications Ltd.
- Hiss, T. (1990). The Experience of Place. New York, Vintage Press.
- Hobsbawn, E. (1983). Introduction: Inventing Traditions. The Invention of Tradition. E. Hobsbawn and T. Ranger. Cambridge, Cambridge University Press.
- Holstein, J. A. and J. F. Gubrium (2002). Active Interviewing. Qualitative Research Methods. D. Weinberg. Oxford, Blackwell Publishers.
- hooks, b. (1990). Yearning: Race, Gender and Cultural Politics. Boston, MA, South End Press.
- Huddart, D. (2006). Homi K. Bhabha. Oxon, Routledge.
- Jackson, J. B. (1984). Discovering the Venacular Landscape. New Haven, Yale University Press.
- Jallad, P. (1999). Death in the Victorian Family. Oxford, Oxford University press.
- Kiberd, D. (1995). Inventing Ireland: The Literature of the Modern Nation. London, Vintage.
- Kiberd, D. (1997). Modern Ireland: Postcolonial or European. Not On Any Map: Essays on Postcoloniality and Cultural Nationalism. S. Murray. Exeter, Exeter University Press.
- Kiberd, D. (1998). "Romantic Ireland is Dead and Gone: The English-speaking Republic as the crucible of modernity " The Times Literary Supplement June 12.
- Kiberd, D. (2003). "Museums and Learning." Moving Worlds: A Journal of Transcultural Writings 3(1): 3 -18.
- King, B., Ed. (1995). West Indian Literature. London, Macmillan Education Ltd.
- Koh, A. (2001). "Said's paradoxical identities." Postcolonial Studies 4(1): 105 - 108.
- Korzybski, A. (1931). A Non-Aristolian System and it's Necessity for Rigour in Mathematics and Physics. The American Mathematical Society. New Orleans.
- Kreilkamp, V., Ed. (2003). Eire/Land. Massachusetts, McMullen Museum of Art, Boston College.

- Kusenbach, M. (2003). "Street phenomenology: the go-along as ethnographic research tool." Ethnography 4: 455-485.
- Lather, P. (1993). "Fertile Obsession: Validity after poststructuralism." Sociological Quarterly 34: 673 - 694.
- Law, L. (1997). *Dancing on the Bar: Sex, Money and the Uneasy Politics of Third Space.* Geographies of Resistance. S. Pile and M. Keith. London, Routledge.
- Least Heat-Moon, W. (1991). PrairyErth (a deep Map). Boston, Houghton Mifflin.
- Leersen, J. (1998). "The Recurrence of Violence and Two Conceptualisations of History." The Irish Review 22: 37 - 45.
- Lefebvre, H. (1991). The Production of Space. Oxford, Blackwell.
- Ley, D. and J. Duncan (1993). Epilogue. Place/ Culture/ Representation. J. Duncan and D. Ley. London, Routledge.
- Lippard, L. (1997). The Lure of the Local: Senses of Place in a Multicentered Society. New York, The New Press.
- Lloyd, D. (1993). Anomalous States: Irish Writing and the Postcolonial Moment. Dublin, Lilliput.
- Lloyd, D. (1999). Ireland After History. Cork, Cork University Press.
- Lloyd, D. (2001). "Regarding Ireland in a Post-colonial Frame." Cultural Studies 15(1): 12 - 32.
- Lloyd, D. (2003). "Editorial - Ireland's Modernities." interventions 5(3): 317 - 321.
- Longley, E. (1997). The Living Stream: Literature and Revisionism in Ireland. Cork, Bloodaxe Books.
- Lomba, A. (1998). Colonialism/ Postcolonialism. London, Routledge.
- Loveman, M. (2005). "The modern state and the primitive accumulation of symbolic power." American Journal of Sociology 110(6): 1651 - 83.
- Macnaghten, P. and J. Urry (1998). Contested Natures. London, Sage Publications.
- Macnaghten, P. and J. Urry (1998). Contested Natures (Theory, Culture & Society). London, Sage Publications Ltd.
- Marcus, J. (2001). *Orientalism.* Ethnography. P. Atkinson, A. Coffey, S. Delamont, L. J. and L. Lofland. London, Sage Publications Ltd.
- Martin, G. (2004). Past Futures - The Impossible Necessity of History. Toronto,

University of Toronto Press.

Marx, K. and F. Engels (1972). Ireland and the Irish Question. London, Intl Pub.

Massey, D. (1992). "Politics and Space/ Time." New Left Review 196(November/ December).

Massey, D. (1994). Space, Place and Gender. Cambridge, Polity Press.

McCarthy, C. (2000). Modernisation - Crisis and Culture in Ireland 1969 - 1992. Dublin, Four Courts Press.

McClintock, A. (1995). Imperial Leather. New York, Routledge.

McCullen, J. (1993). Management Plan 2004, Duchas.

McLennan, G. (2002). "Sociological Cultural Studies: The Question of Explanation." Cultural Studies 16(5): 631-649.

McLennan, G. (2003). "Sociology, Eurocentricism and Postcolonial Theory." European Journal of Social Theory 6(1): 69-86.

McLeod, J. (2000). Beginning Postcolonialism. Manchester, Manchester University Press.

Merrifield, A. (2000). Henri Lefebvre: A socialist in space. thinking space. M. Crang and N. Thrift. London, Routledge: 167 - 182.

Mills, C. W. (1967). The Sociological Imagination. London, Oxford University Press.

Mitchell, K. (1997). "Different Diasporas and the Hype of Hybridity." Environment and Planning D: Society and Space 1997 15: 533-553.

Moloney, S. (2006). The Phoenix Murders: Conspiracy, Betrayal and Retribution. Dublin, Mercier Press.

More, T. (1985). Utopia. London, J.M. Dent.

Murray, S., Ed. (1997). Not On Any Map: Essays on Postcoloniality and Cultural Nationalism. Exeter, University of Exeter Press.

Nietzsche, F. (1895). Twilight of the Idols. Dover, Dover Publications Inc.

Nolan, B. (2006). Phoenix Park: A History and Guidebook. Dublin, The Liffey Press.

O'Reilly, T. (2005). "Ireland the Second Richest Country in Europe." http://radar.oreilly.com/archives/2005/06/ireland_the_sec.html Retrieved 9th January, 2006.

Parry, B. (1996). Problems in Current Theories of Colonial Discourse. The Post-

- Colonial Studies Reader. B. Ashcroft, G. Griffiths and H. Tiffin. London, Routledge: 36-44.
- Parsons, D. L. (2003). A Cultural History of Madrid: Modernism and the Urban Spectacle Oxford, Berg Publishers
- Páseta, S. (2003). Modern Ireland: A Very Short Introduction. Oxford, Oxford University Press.
- Penniman, T. K. (1935). One Hundred Years of Anthropology. London, Duckworth.
- Pile, S. (2000). The Troubled Spaces of Frantz Fanon. thinking space. M. Crang and N. Thrift. London, Routledge.
- Prichard, J. (1973). Researches into the Physical History of Mankind. London, University of Chicago Press.
- Reid, L. and M. Brennock (2006). Farmleigh lodge planned as residence for future taoisigh. The Irish Times. Dublin.
- Relph, E. (1976). Place and placelessness. London, Pion.
- Richardson, L. (1995). Narrative and Sociology. Representations in Ethnography. V. Maanen. London, Sage.
- Rorty, R. (1987). Contingency, Irony and Solidarity. Cambridge, Cambridge University Press.
- Rose, N. (1999). Powers of Freedom: reframing political thought. Cambridge, Cambridge University Press.
- Rushdie, S. (1992). Imaginary Homelands. London, Granta.
- Rutherford, J. (1990). The Third Space: Interview with Homi Bhabha. Identity, Community, Culture, Difference. J. Rutherford. London, Lawrence and Wishart: 207-221.
- Said, E. (1978). Orientalism. London, Routledge and Kegan Paul.
- Said, E. (1994). Culture and Imperialism. London, Chatto and Windus.
- Said, E. (2000). Reflections in Exile and other Literary and Cultural Essays. London, Granta.
- Said, E. (2003). Afterword: Reflections on Ireland and Postcolonialism. Ireland and Postcolonial Theory. C. Carroll and P. King. Cork, Cork University Press: 177 - 187.

- Sayers, S. (2004). "Irish Myth and Irish National Consciousness." Irish Studies Review 12(3): 271 - 281.
- Schama, S. (1995). Landscape and Memory. London, HarpersCollinsPublishers.
- Sharp, J., P. Routledge, et al., Eds. (2000). Entanglements of Power - Geographies of Domination and Resistance. London, Routledge.
- Shields, R. (1992). Places on the Margin Alternative geographies of modernity. New York, Routledge.
- Sidaway, J. D. (2002). Postcolonial Geographies: Survey - Explore - Review. Postcolonial Geographies. A. Blunt and C. McEwan. London, Routledge.
- Sluyter, A. (2002). Colonialism and Landscape: Postcolonial Theory and Applications. New York, Rowman & Littlefield.
- Smith, A. (2003). Landscape Representation: Place and Identity in Nineteenth-Century Ordnance Survey Maps of Ireland. Landscape, Memory and History: Anthropological Perspectives. P. J. Stewart and A. Strathern. London, Pluto Press: 71 - 88.
- Smith, C. (2001). "Looking for Liminality in Architectural Space." http://limen.mi2.hr/limen1-2001/catherine_smith.html Retrieved 18th July 2005.
- Smith, F. M. (2000). The Neighbourhood as site for contesting German reunification. Entanglements of Power: geographies of domination/ resistance. J. Sharp, P. Routledge, C. Philo and R. Paddison. London, Routledge.
- Smith, M. P. (1992). "Postmodernism, Urban Ethnography, and the New Social Space of Ethnic Identity." Theory and Society 21(4 (Aug. 1992)): 493 - 531.
- Soja, E. (1989). Postmodern Geographies: The Reassertion of Space in Critical Social Theory. London, Verso Press.
- Soja, E. (1996). Thirdspace: Journeys to Los Angeles and Other Real-and-Imagined Places. Oxford, Basil Blackwell.
- Solnit, R. (1994). "Elements of a New Landscape." Visions of America: Landscape as Metaphor at the End of the 20th Century. M. Friedman, J. Beardsley, L. Furlong et al. Denver, Denver Art Museum.
- Solnit, R. (2001). Wanderlust: A history of Walking. London, Verso.
- Spivak, G. C. (1976). Introduction. Of Grammatology. Baltimore, John Hopkins.

- Spivak, G. C. (1987). In Other Worlds: Essays in Cultural Politics. New York, Methuen.
- Spivak, G. C. (1988). Introduction: Subaltern Studies: Deconstructing Historiography. Selected Subaltern Studies. R. Guha and G. C. Spivak. Delhi, Oxford University Press: 3 - 34.
- Spivak, G. C. (1990). In Other Words: Essays in Cultural Politics, Routledge.
- Spivak, G. C. (1999). A Critique of Postcolonial Reason: Towards A History of a Vanishing Present. Cambridge; Calcutta, Harvard University Press; Seagull Press.
- Stallybrass, P. and A. White (1986). The Politics and Poetics of Transgression. London, Methuen.
- Strathern, M. (1991). Partial Connections. Maryland, Rowman and Littlefield.
- Thompson, S. (2001). "Introduction: Towards an Irish Cultural Studies." Cultural Studies 15(1): 1 -11.
- Thoreau, H. T. (1995). Walking. New York, Penguin Books.
- Trinh, T. M.-H. (1989). Women, native other: Writing postcoloniality and feminism. Bloomington, Indiana University Press.
- Trinh, T. M.-H. (1992). Framer Framed. New York, Routledge.
- Turner, V. (1974). Dramas, fields and metaphors: Symbolic action in human society. Ithaca, NY, Cornell University Press.
- Turner, V. (1977). "Frame, Flow and Reflection." Performance in Postmodern Culture. M. Benamou and C. Caramello. Madison, WI, Coda Press: 32-55.
- Turner, V. (1982). From Ritual to Theatre: The Human Seriousness of Play. New York, Performing Arts Journal Publication.
- Turner, V. (1985). On the edge of the bush: Anthropology as experience. Tucson, AZ, University of Arizona Press.
- Turner, V. (1986). The anthropology of performance. New York, Performing Arts Journal Publications.
- Urry, J. (2000). Sociology beyond Societies: mobilities for the twenty-first century. London and New York, Routledge.
- van Gennep, A. (1960). The Rites of Passage. London, Routledge.
- Walkerdine, V., H. Lucey, et al. (2002). Subjectivity and Qualitative Method.

- Qualitative Research in Action. T. May. London, Sage: 179 - 196.
- West, C. (1990). The New Cultural Politics of Difference. Out There. R. Ferguson. Cambridge, MA, MIT Press and New York: New Museum of Contemporary Art.
- Whelan, Y. (2001). "Symbolising the State - the iconography of O'Connell Street and environs after Independence (1922)." Irish Geography 34(2): 135 -156.
- Whelan, Y. (2002). "The construction and destruction of a colonial landscape: monuments to British monarchs in Dublin before and after independence." Journal of Historical Geography 28(4): 508 - 533.
- Whelan, Y. (2003). Reinventing Modern Dublin. Dublin, University College Dublin Press.
- Williams, R. (1981). Culture. London, Fontana.
- Willis, P. (2000). The Ethnographic Imagination. London, Polity Press.
- Yeats, W. B. (2000). The Collected Poems of W.B.Yeats Hertfordshire, Wordsworth Poetry Library.
- Yeoh, B. S. A. (2001). "Postcolonial Cities." Progress in Human Geography 25(3): 456 - 468.
- Young, R. J. C. (1990). White Mythologies: Writing History and the West. London and New York, Routledge.
- Young, R. J. C. (1995). "Foucault on Race and Colonialism." New Formations 25(Spring): 57 - 66.
- Zieleniec, A. J. L. (2006). The Medicalisation of Space: The medical discourse of the origins of Glasgow's public parks. British Sociological Association. Harrogate.
- Zukin, S. (1991). Landscapes of Power, From Detroit to Disney World. London, University of California Press, Ltd.

Websites

www.opw.ie, accessed 9th September 2005

www.irelandheritage.ie, accessed 12th October, 2005

www.indymedia.ie, accessed 19th June, 2005

www.catholicireland.net, accessed 17th March, 2005

www.progressivedemocrats.ie/pressroom/2265, accessed 2nd April, 2006

www.finance.gov.ie, accessed 11th February 2006

Interviews

Chief Superintendent, 13th December 2005. Restaurant in Visitor Centre, Phoenix Park.

Superintendent, 21st June, 2005. Whitefields, Phoenix Park.

Head Guide, 8th May, 2005. Visitor Centre, Phoenix Park.

Architect, 9th May, 2005. OPW, St Stephens Green, Dublin.

PR person for the Park, 11th May, 2005. OPW, St Stephens Green, Dublin.

Resident J, 23rd October, 2006. Resident's lodge, Phoenix Park.

Visitors 1-5, 10th October, 2005. Phoenix Park (various locations)

Visitors 6 – 10, 5th January, 2006. Phoenix Park (various locations)

Visitors 11- 15, 3rd March, 2006. Phoenix Park (various locations)

Visitors 16, 17, 5th April, 2006. Phoenix Park (various locations)

Appendix 1



Appendix 2

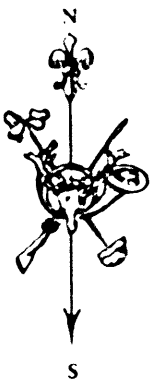

Appendix 3

ASHTOWN DEMESNE PHOENIX PARK 11th APRIL '92 11AM

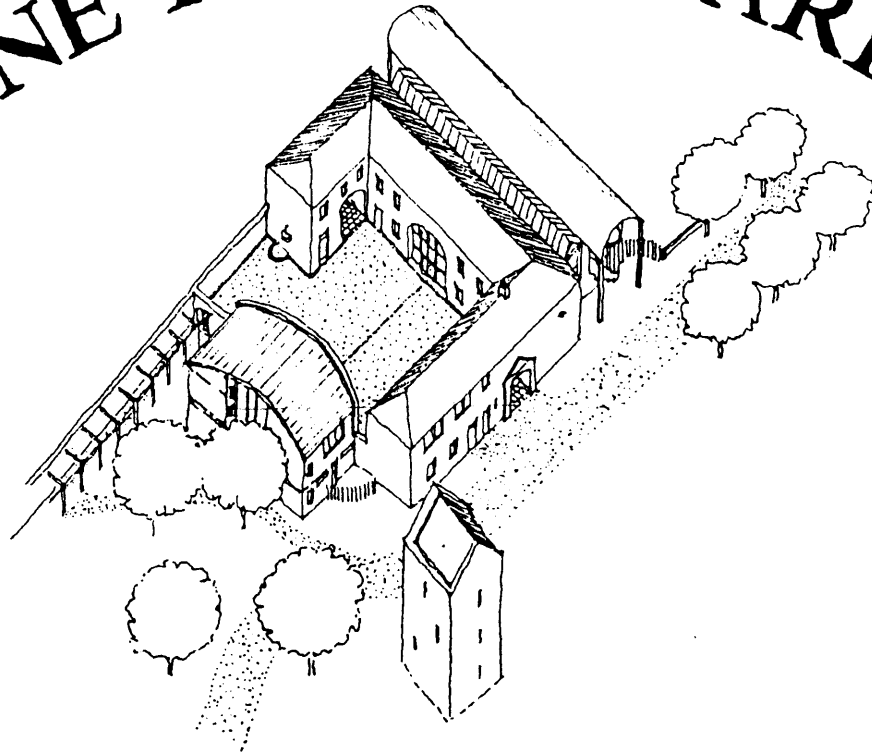

NEW WORKS & RESTORED TOWER HOUSE

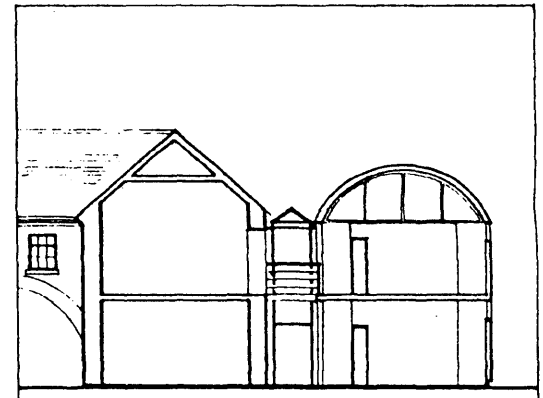
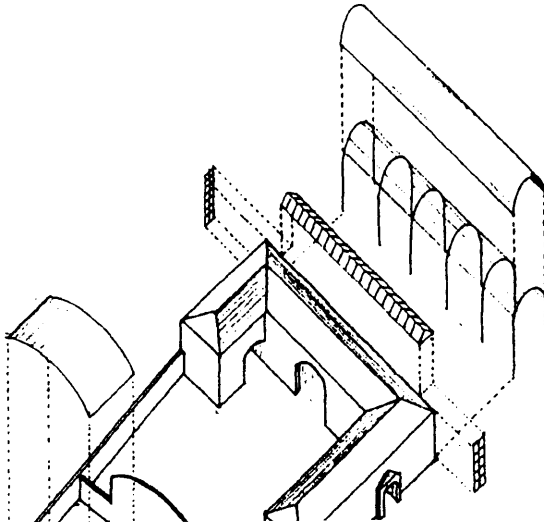
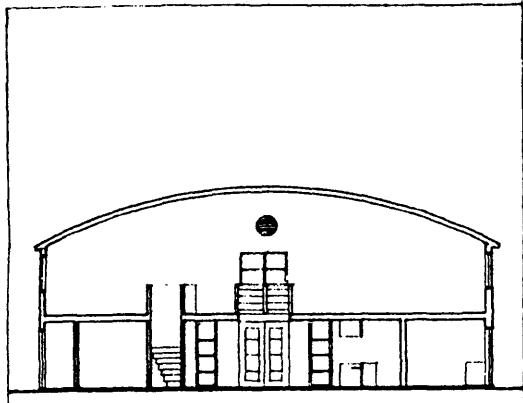

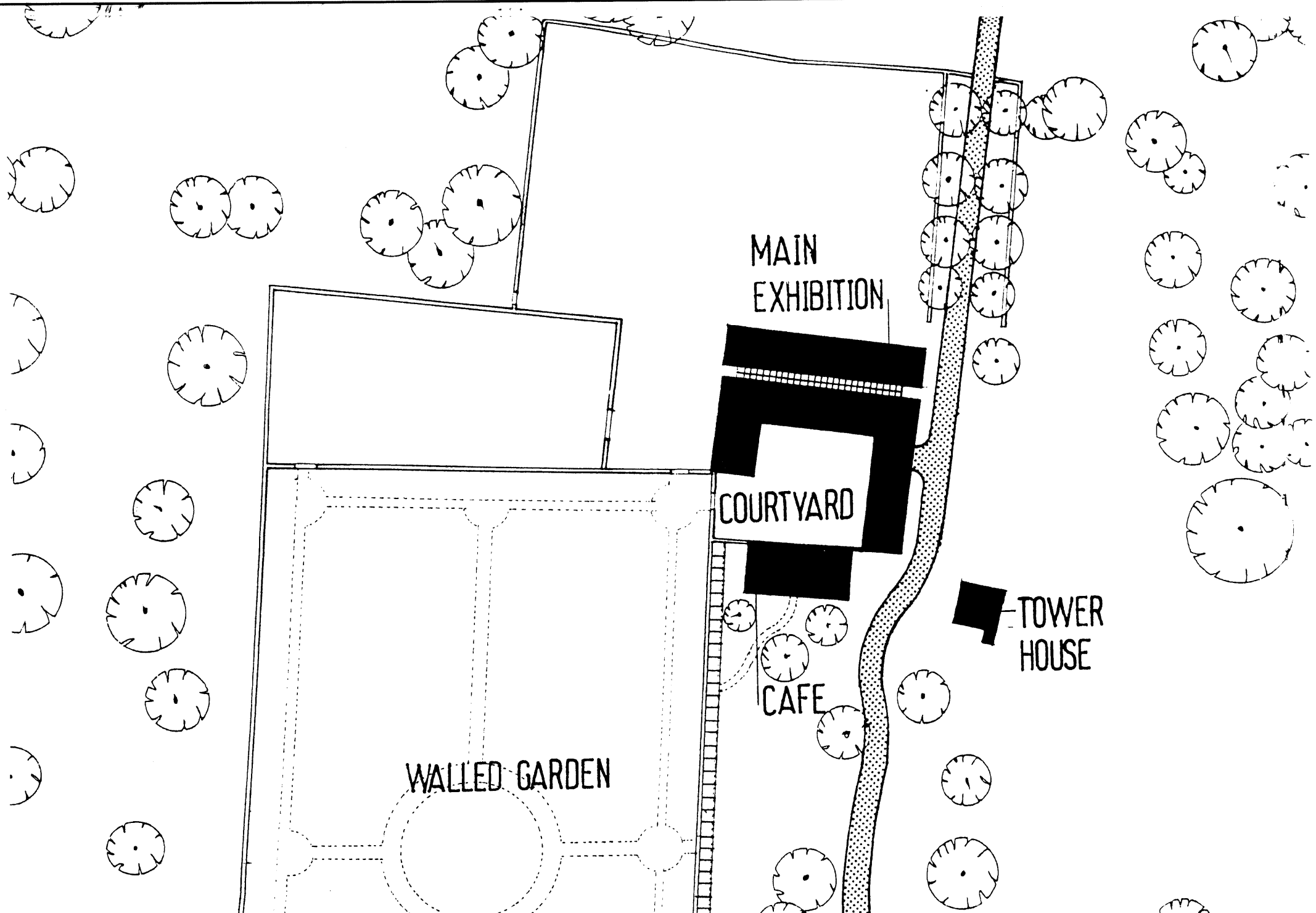

MAIN
EXHIBITION

COURTYARD

TOWER
HOUSE

CAFE

WALLED GARDEN