

# A System Dynamics Perspective of Forecasting in Supply Chains

---

by

Qinyun Li

*A Thesis Submitted in Fulfilment of the Requirements for  
the Degree of Doctor of Philosophy of  
Cardiff University*

*Logistics Systems Dynamics Group  
Logistics and Operations Management Section of Cardiff Business School,  
Cardiff University*

September 2014

## DECLARATION

This work has not been submitted in substance for any other degree or award at this or any other university or place of learning, nor is being submitted concurrently in candidature for any degree or other award.

Signed ..... (Qinyun Li)      Date .....

## STATEMENT 1

This thesis is being submitted in partial fulfillment of the requirements for the degree of .....(insert MCh, MD, MPhil, PhD etc, as appropriate)

Signed ..... (Qinyun Li)      Date .....

## STATEMENT 2

This thesis is the result of my own independent work/investigation, except where otherwise stated.

Other sources are acknowledged by explicit references. The views expressed are my own.

Signed ..... (Qinyun Li)      Date .....

## STATEMENT 3

I hereby give consent for my thesis, if accepted, to be available for photocopying and for inter-library loan, and for the title and summary to be made available to outside organisations.

Signed ..... (Qinyun Li)      Date .....

## STATEMENT 4: PREVIOUSLY APPROVED BAR ON ACCESS

I hereby give consent for my thesis, if accepted, to be available for photocopying and for inter-library loans **after expiry of a bar on access previously approved by the Academic Standards & Quality Committee.**

Signed ..... (Qinyun Li)      Date .....

## **Acknowledgement**

Pursuing a PhD in Cardiff is the biggest decision I ever made. It is a four-year project, but would not have been possible to finish this journey without the help and support of the kindest people around me, to only some of whom it is possible to give particular mention here.

Foremost, I would like to express my sincere gratitude to Professor Stephen Disney, the primary supervisor of my PhD research. I would never forget the “toil, tears and sweat” we shared in these four years. To me, he is more than a supervisor, a master, a friend. The collaboration with him is enjoyable and effective, making my research more critical, valuable, and publishable. I would also like to thank Professor Mohamed Naim and Dr. Andrew Potter in my PhD supervision team for their encouragement and hard questions. I have been extremely lucky to have three supervisors with immense knowledge.

Suggestions from Logistics Systems Dynamics Group (LSDG) had improved my research quality and presentation skills. Members from Logistics and Operations Management (LOM) section offered opportunities and supports in different ways in my life. There are many names I would never forget: Dr. Virginia Spiegler, Dr. Po-ngarm Ratanachote, Dr. Poti Chao, Dr. Po-Lin Lai, Mr. Shang-Min Lin, Professor Aris Syntetos, Dr. Jonathan Gosling, Dr. Irina Harris, Dr. Fotios Petropoulos, Dr. Wessam Abouarghoub, Dr. Maneesh Kumar, Dr. Xun Wang, Professor Helen Walker, Dr. Sharon Williams, Dr. Ann Esain, Mrs Jane Lynch, Mr. Daniel Eyers, Mr. Anthony Alexander.

I would like to acknowledge the professional services in the LOM section and Cardiff Business School, including Ms. Elaine Adams, Ms. Penny Smith, Ms. Elsie Phillips, Ms Laine Clayton, Mr. Wayne Findlay, Ms. Vikki Burge, and Mr. Tim Derrick.

My sincere thanks also goes to Professor Gerard Gaalman from Groningen University (Netherlands), and Professor Kostas Nikolopoulos from Bangor University (UK). Their suggestions and comments on my research led to the publication in International Journal of

Production Economics. Special thanks to my examiners Professor Aris Syntetos from Cardiff University (UK) and Professor Robert Boute from KU Leuven (Belgium).

Those people from Zi's Café and .cn (two Chinese restaurants), who provided a much needed form of escape from my studies, also deserve thanks.

Last but not the least, I must express my gratitude to Linli (Sunny) Qi, my wife, Longlan Ma, my mom, Zexin Li, my dad, for their patience, care and smile. They are the core energy throughout this journey.

## **Abstract**

**Purpose:** To evaluate the impact of forecasting on supply chain via a system dynamics perspective.

**Method/approach:** Techniques from Control Theory (such as block diagram,  $z$ -transforms, Fourier transforms, Jury's Inners approach, and frequency response analysis) and Time Series Analysis are used to investigate the performance of supply chains analytically. Simulation is also used to verify the results.

**Findings:** This thesis provides a new and complete proof to the knowledge that Naïve, simple exponential smoothing, and Holt's forecasting when used in the Order-Up-To (OUT) policy always produce the bullwhip effect for any demand pattern and for all lead-times. In terms of the bullwhip performance when Damped Trend (DT) forecasts are used in the OUT policy, the bullwhip effect is always generated for traditional parameter suggestions. However, the bullwhip avoidance behaviour occurs for some unconventional parameter values. Using these unconventional parameter values, the DT / OUT system acts like a low-pass filter that can eliminate the bullwhip effect and maintain good inventory performance at the same time. The thesis also proves that the Proportional Order-Up-To (POUT) policy is able to reduce system nervousness at the manufacturer. Moreover, the proportional future guidance (PFG) mechanism proposed may reduce system nervousness and inventory costs at the manufacturer and reduce the bullwhip effect in the supply chain simultaneously.

**Implications:** This thesis shows that the bullwhip and net stock variance reduction behaviours exist when unconventional parameter values are used in the DT forecasting procedure. It is the first evidence that it is possible to design a system with good financial performance but without directly looking into the performance of forecasting. The thesis is also the first to consider the MRP nervousness problem and the bullwhip effect at the same time. The PFG method proposed is easy to understand, and since it does not require sophisticated integrated IT systems, or demand / inventory information sharing, it should be easy to implement.

## Table of Contents

Acknowledgement .....	i
Abstract .....	iii
1. Introduction .....	1
1.1 Background .....	1
1.2 Research questions .....	8
1.3 Thesis structure .....	10
1.4 Definitions.....	12
2. Literature Review .....	14
2.1 Supply Chain Dynamics.....	15
2.1.1 Inventory control.....	15
2.1.2 Bullwhip effect.....	17
2.1.3 Information sharing.....	21
2.2 Forecasting.....	24
2.2.1 Simple exponential smoothing.....	25
2.2.2 Holt's method.....	26
2.2.3 Damped trend method.....	26
2.2.4 ARIMA models.....	29
2.2.5 Demand forecasting and supply chain research.....	31
2.2.6 Order forecasting.....	32
2.3 System Nervousness .....	33
2.4 Summary .....	37
3. Methodology.....	40
3.1 Research philosophies.....	40
3.2 Research methods and theories .....	42
3.3 Research strategy .....	46
3.4 Summary .....	47
4. Damped Trend Forecasting and the Order-Up-To Replenishment Policy .....	48
4.1 Transfer function of Damped Trend forecasting.....	49
4.2 Stability of Damped Trend forecasts via Jury's Inners approach .....	50
4.3 Invertibility and Stability .....	55

4.4	Integrating Damped Trend forecasting into the Order-Up-To policy .....	57
4.5	Summary .....	62
5.	Bullwhip and Net Stock Amplification of the Damped Trend Order-Up-To Policy .....	64
5.1	The Bullwhip effect and net stock amplification in the frequency domain .....	64
5.2	Frequency response of three special cases of the Damped Trend Order-Up-To policy (with Naïve, SES, or Holts forecasts).....	69
5.3	Frequency response of the OUT policy with Damped Trend forecasts .....	72
5.4	Net stock amplification of the Damped Trend Order-Up-To system.....	85
5.5	Summary .....	87
6.	Numerical Verification of the Damped Trend Order-Up-To Policy .....	89
6.1	Verification of the low and high frequency harmonic behaviour of the Damped Trend Order-Up-To policy .....	90
6.2	Application to a real-world data set .....	91
6.3	Analysis of 62 real-world demand data sets .....	95
6.4	Summary .....	102
7.	System Nervousness .....	104
7.1	Methods to generate future guidance .....	105
7.1.1	Scenario A: The order-up-to (OUT) replenishment policy .....	106
7.1.2	Scenario B: The proportional order-up-to replenishment policy .....	107
7.1.3	Scenario C: The POUT policy with damped future order guidance .....	108
7.2	Measuring system nervousness: The accuracy of the future guidance .....	109
7.2.1	The case of the auto-regressive demand pattern .....	110
7.3	Analysis of the three scenarios.....	113
7.3.1	Comparison of the nervousness in Scenario A and B .....	113
7.3.2	Comparison of the nervousness in Scenario B and C .....	116
7.3.3	Inventory and bullwhip performance in the supply chain.....	119
7.3.3.1	Inventory performance in three scenarios .....	120
7.3.3.2	Bullwhip in three scenarios.....	123
7.4	Summary .....	126
8.	Conclusions .....	129
8.1	Discussion of the primary research question .....	129
8.2	Discussion of the second research question .....	133
8.3	Implications and limitations.....	137
8.3.1	DT / OUT.....	137
8.3.2	POUT and PFG .....	139
8.4	Summary .....	141

9. References ..... 142

10. Appendix: Autocalculation of variance via Jury’s Inners ..... 167

11. Appendix: Deriving the measures of order stream accuracy..... 170

12. Appendix: The variance of the manufacturer’s net stock..... 175

13. Appendix: Proof to  $T_i^{-1} < 1 - \rho$  enables  $\sigma_o^2 < \sigma_d^2$  for  $\rho > 0$  and  $T_p \in \mathbb{N}_0$  ..... 177

14. Appendix: Behaviour of the manufacturer’s order variance in Scenario C ..... 179



## List of Figures

Figure 1.1 Bullwhip in a supply chain .....	2
Figure 1.2 Focus of the thesis .....	8
Figure 1.3 Thesis structure.....	10
Figure 4.1 Block diagram of the Damped Trend forecasting method .....	49
Figure 4.2 Damped Trend stability region.....	53
Figure 4.3 Block diagram of Damped Trend Order-Up-To system.....	57
Figure 5.1 Frequency response of the OUT policy with Naïve, SES and Holts forecasts.....	69
Figure 5.2 Possible settings that result in $AR < 1$ near $\omega = 0$ when $T_p = 1$ .....	74
Figure 5.3 Possible settings that result in $AR \leq 1$ near $\omega = \pi$ when $T_p = 1$ .....	76
Figure 5.4 Number of stationary points within $\omega \in (0, \pi)$ and value of $AR$ near $\omega = 0$ and $\omega = \pi$ when $T_p = 1$ .....	79
Figure 5.5 Some examples of the $AR$ plot when $T_p = 1$ .....	81
Figure 5.6 Lower boundary of $\beta$ changes with $T_p$ .....	84
Figure 5.7 $AR$ plot of $NSAmp$ when $\phi = 0.5$ , $\alpha = -0.9$ , $\beta = -1.01$ , $T_p = 1$ .....	87
Figure 6.1 FFT analysis of the demand for a FMCG in the household goods category .....	92
Figure 6.2 Simulated response by the OUT policy with DT forecasts .....	92
Figure 6.3 Investigation of the performance of the necessary bullwhip criterion .....	93
Figure 6.4 Investigation of $NSAmp$ .....	95
Figure 6.5 Illustration of 62 real-world data sets .....	98

Figure 6.6 The bullwhip and <i>NSAmp</i> when the objective is to minimise $\sigma_o$ .....	99
Figure 6.7 Bullwhip and <i>NSAmp</i> when objective function is to minimise $\sigma_{ns}$ .....	99
Figure 6.8 Bullwhip and <i>NSAmp</i> of 62 real-world data sets when $\sigma_o + \sigma_{ns}$ is minimised, together with the optimisation forecasting parameters .....	101
Figure 7.1 Influence of $T_i$ when $T_p = 1$ , $m = 3$ .....	114
Figure 7.2 Impact of lead time when $m = 2$ .....	115
Figure 7.3 Accuracy of different forecasted orders for i.i.d. demand when $T_i = 5$ .....	117
Figure 7.4 Percentage improvements when $T_p = 1$ .....	118
Figure 7.5 Odd-even lead time effect on the impact of $T_i$ in Scenario C.....	119
Figure 7.6 Net stock variance in a two-echelon supply chain .....	122

## List of Tables

Table 1.1 Real-life example of call-offs and order forecasts.....	6
Table 2.1 Definitions for information sharing .....	22
Table 4.1 Transfer functions of $\hat{d}_{t,t+T_p+1}$ and $dwip_t$ for the special cases of Damped Trend Order-Up-To system .....	62
Table 5.1 Conditions and possible solutions for Equation (5.23).....	78
Table 5.2 Bullwhip avoidance area in Figure 5.3a changes with different $T_p$ .....	84
Table 6.1 Numerical results from a 4000 period simulation verifying theoretical results .....	90
Table 6.2 Description of 62 real-world data sets .....	97
Table 7.1 Summary of the three scenarios.....	109
Table 10.1 The Mathematica code to find the variance using Jury's Inners approach.....	167
Table 11.1 Coefficients in $\hat{o}_{t-j,t}$ .....	174

## **1. Introduction**

This chapter aims to outline the background for undertaking this research, to state the research questions proposed in the study, and to briefly introduce the contents in each chapter.

### **1.1 Background**

Academia and practice often strive to improve the accuracy of forecasting methods, not only because accuracy is considered as the objective of forecasting but also due to its importance to many business decisions. Notably, the Damped Trend (DT) forecasting method (Gardner and McKenzie, 1985) has been recognised for its superior accuracy in the so-called M-competitions (Makridakis and Hibon, 2000; Fildes et al., 2008; Gardner and McKenzie, 2011). By dampening a linear trend, the method improves long-term forecast accuracy without significantly degrading short-term accuracy. A number of popular forecasting models such as Naïve, simple exponential smoothing, Holt's method are special cases of the general DT model that can be accessed by tuning the forecasting system parameters. This allows for model detection and forecast of a wide range of time series with or without trends.

Another school of thought in the forecasting literature recognises that forecast accuracy must be distinguished from empirical utility (Mahmoud and Pegels, 1989; Gardner, 1990; Timmermann and Granger, 2004; Boylan, 2007; Syntetos and Boylan, 2008). The fact that forecasting model A outperforms B in terms of forecast accuracy, does not necessarily imply method B's superiority will be reflected in another performance measure. For example, improved forecast accuracy is not always translated into better service levels or reduced total inventory costs (Syntetos and Boylan, 2006). Syntetos et al. (2010) further claim that

forecasting in an inventory context should be evaluated on its implications for stock control in addition to forecast accuracy.

Similarly insights have also been revealed in the supply chain management context. For example, in the literature of supply chain dynamics, forecasting has been recognised as one of the main causes of the well-known “bullwhip effect” (Lee et al., 1997a, b; Chen et al., 2000a, b). Even with stylised autoregressive integrated moving average (ARIMA) type demand processes, the minimised mean square errors forecasts do not necessarily minimise bullwhip or inventory variance; see examples in Chen et al. (2000a), Zhang (2004) and Hosoda and Disney (2009).

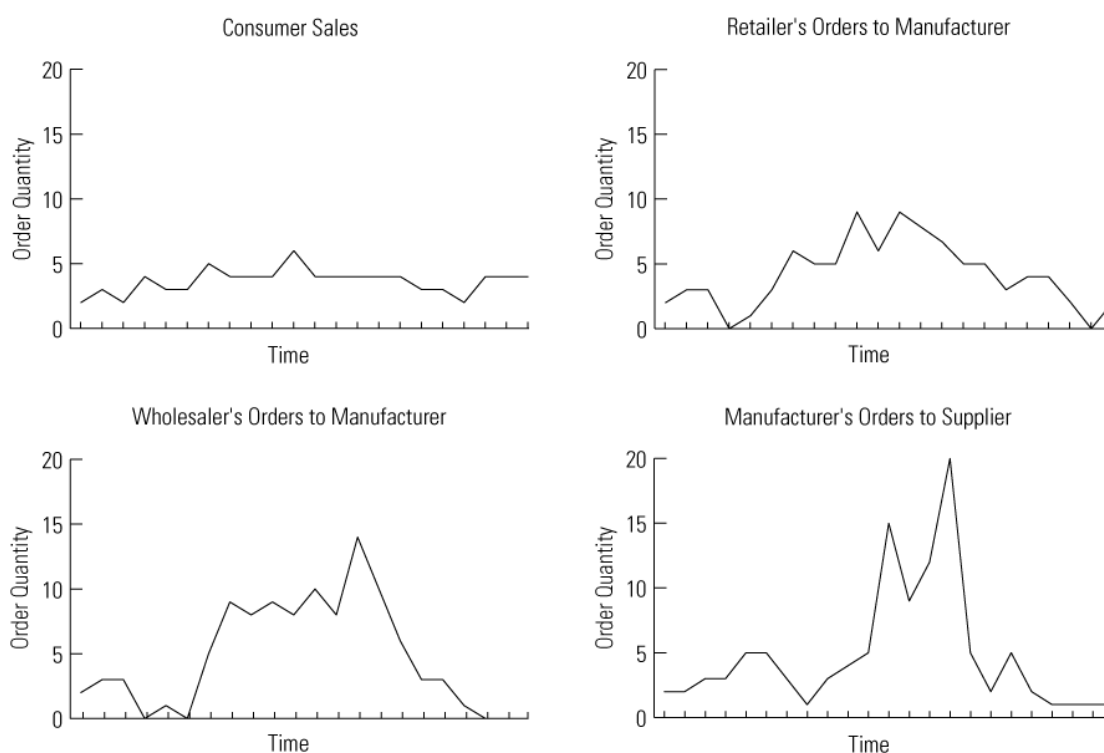

*Figure 1.1 Bullwhip in a supply chain*

(Source: Lee et al. (1997b))

The bullwhip effect is a term that is used to describe the scenario that orders upstream tend to have larger fluctuations than the sales downstream, hence is also called “order variance amplification”. Figure 1.1 gives an example of the bullwhip effect produced by players of the

famous “Beer Game” (Sterman, 1989). It produces severe consequences on the suppliers’ performance, such as excessive capacity, labour idling and over-time (Lee et al., 1997a, b); eventually these costs will be passed onto customer.

Although the term “bullwhip effect” was introduced by Lee et al. (1997a, b), it is not a new supply chain phenomenon. The fundamental reasons of bullwhip categorised in Lee et al. (1997a, b) were already documented in the literature. For example, rationing and gaming was referred to as the Houlihan Effect after Houlihan (1987), order batching is also called the Burbidge Effect (Burbidge, 1991), demand signal processing was highlighted by Forrester (1961) and known as the Forrester Effect or “Demand Amplification”, and price fluctuation exists in the form of the Promotion Effect. The term “bullwhip effect” in this thesis often refers to the Forrester Effect because the impact of forecasting on supply chain dynamics is specifically addressed.

The evidence of the bullwhip effect has often been observed in real world supply chains, such as in Volvo, Cisco, Procter & Gamble, Hewlett-Packard, Philips Semiconductors, Tesco, Lexmark and many others firms (Lee et al., 1997b; De Kok et al., 2005; Potter and Disney, 2010; Disney et al., 2013). For instance, in early 2010, Lexmark’s production of printer toner experienced a bullwhip effect of 5.4 and the net stock amplification ratio of 27.3. Lexmark invested in excessive capacity, extra inventory, work over-time one week and stand idle the next, but eventually the product availability and fill rates were still poor (Disney et al., 2013). One of the main causes identified by Disney et al. (2013) was that the forecasts used by Lexmark had high forecast errors and often had severe bias.

Another problem in supply chains is the “net stock amplification” effect, where the variance of inventory levels is amplified throughout the supply chain. It is important as inventory variance produces inventory holding and backlog costs and has an immediate effect on

customer service metrics such as availability and fill rates. The bullwhip effect and net stock amplification are the most popular topics in supply chain dynamics research as they include capacity concerns and inventory concerns accordingly. Both themes have received considerable attention from academia and industry (Geary et al., 2006).

Although the impact of many forecasting methods on the bullwhip and inventory variance has been studied, studies on the Damped Trend forecasting method in a supply chain context have not yet appeared. Since forecasting should be evaluated based on its utility, this investigation of forecasting will start with a particular focus on the impact of DT forecasting on the bullwhip effect and on the inventory variance.

To study the supply chain dynamics when the Damped Trend forecasting is used, the first task is to make sure the forecasting system is stable. From a forecasting perspective, Gardner and McKenzie (1985) identified the regions of recommended parameter sets for the Damped Trend method. This thesis first answers the question whether this region is the same as the stability region from a control theory perspective.

Some of the work described in this thesis was also partially inspired by Dejonckheere et al. (2003). They investigated the bullwhip effect induced by common forecasting methods such as Naïve, moving averages, simple exponential smoothing when they are used in the Order-Up-To (OUT) policy, and found these systems always generate the bullwhip effect. However, there are a number of differences between their research and those in this thesis. First, the forecasting methods used by Dejonckheere et al. (2003) are not suitable for trend demands. Here, the Damped Trend forecasting method not only forecasts demand with or without trends, but also contains a number of special forecasting techniques such as Naïve and simple exponential smoothing. It is interesting to investigate the bullwhip performance of the OUT policy with the Damped Trend forecasting. As the DT forecasting method effectively

automates model selection, its performance should at least be as good as its special cases (i.e. Naïve and simple exponential smoothing), and could be even better. Second, the conjecture that the OUT policy with Naïve and exponential smoothing forecasts always produces bullwhip in Dejonckheere et al. (2003) was not formally proved. We provide a complete proof to their conjecture.

There is another aspect of supply chain dynamics studied in the thesis, “system nervousness”. In the majority of the literature, this problem is discussed within the context of manufacturing, where the effect is identified as the result of intensively modifying the master production schedule in materials requirement planning (MRP) systems. It is induced by the behaviour of downstream players in a supply chain, such as a practice of issuing “order call-offs” and “order forecasts”. This practice is common in automotive, electronics and manufacturing industries (Harrison, 1997), partially because organisations are often reluctant to share consumer demand information or production and inventory policies for commercial and technical reasons (Holweg et al., 2005).

Table 1.1 demonstrates the practice of issuing “call-offs” and “order forecasts” between a local manufacturer in the UK and their supplier. The manufacturer places purchase orders every week to its suppliers. In each replenishment cycle (a week in this example, but it could be as short as a few hours, or as long as a month or so), a firm order (also called the “call-off” order) is given to the supplier instructing them of how much to dispatch in the current period, as well as some future guidance of the likely (but not guaranteed) orders in the future – these are the “order forecasts”. In Table 1.1, the bold numbers are call-offs and the rest of the numbers are order forecasts. Note, all the information are produced by the downstream player (the UK manufacturer in this case) and send to the upstream player (the supplier) on a weekly basis.



Quantity		For delivery in week									
		1	2	3	4	5	6	7	8	9	10
Orders placed in week	1	<b>0</b>	1620	2160	4860	8100	8100	8100	0	-	-
	2	-	<b>1620</b>	5940	7020	8100	7560	4860	7020	0	-
	3	-	-	<b>5400</b>	5940	8100	7560	4860	7020	0	7020

Table 1.1 Real-life example of call-offs and order forecasts

(Key: Call-off orders in Bold)

On week 1, the manufacturer did not order anything (the (1,1)<sup>th</sup> entry of the matrix in Table 1.1), but they told the supplier what would be required for at least the next seven weeks (the (1, j)<sup>th</sup> entry of the matrix in Table 1.1,  $j = 2, 3, 4, 5, 6, 7, 8$ ). This future guidance is used by suppliers to initiate production, procure raw materials and components, and to plan labour and capacity acquisitions. In practice, suppliers often use MRP systems to facilitate this task, especially when many products and components are present.

In the second week, the UK manufacturer generated another purchase order with call-off quantity of 1620 (the (2,2)<sup>th</sup> entry of the matrix in Table 1.1) and seven order forecasts (the (2, j)<sup>th</sup> entry of the matrix in Table 1.1,  $j = 3, 4, 5, 6, 7, 8, 9$ ), then passed the information to their supplier. The call-off order quantity was the same as the forecast for the 2<sup>nd</sup> week in the 1<sup>st</sup> purchasing order. However, some of the future order forecasts were updated. The prediction for week 3 was increased from 2160 to 5940. The order forecast for week 4 was increased from 4860 to 7020.

In week 3, another purchase order was sent to the supplier. This time, the call-off for week 3 was no longer 5940 as the manufacturer predicted last week, but 5400. The UK manufacturer also informed their supplier that they probably only would need 5940 units of products instead of 7020 units on the 4<sup>th</sup> week.

It is easy to notice from the example above, the downstream player changes the prediction of future order quantity period-by-period, and because of that, the supplier has to update their master production schedule for the new information frequently, leading to the problem known as “system nervousness” (Mather, 1977). System nervousness causes problems in MRP systems as quantity increases within the lead time cannot be met without expediting production (or delivery), whereas quantity decreases result in excessive inventory being accumulated. It also leads to reduced productivity and confusion on the shop floor (Campbell, 1971; Hayes and Clark, 1985). It can be appreciated that the variability of the orders (call-offs) is related to the “bullwhip” problem (Dejonckheere et al., 2003). Bullwhip results in production and replenishment plans that have unduly high variability and this causes capacity losses and increased inventory requirements (Disney and Lambrecht, 2007).

Despite the popularity of the practice of issuing call-offs and order forecasts, many companies will experience both system nervousness and bullwhip simultaneously. This is a distressing, but realistic, set of circumstances. There appears to be no previous literature that considers the system nervousness problem and the bullwhip together. However, in the literature, it is shown that a linear policy known as the Proportional Order-Up-To policy is able to eliminate the bullwhip effect (Disney et al., 2004). This thesis then investigates whether or not this technique is able to help forecasting reduce the discrepancies between order forecasts and call-offs thereby reducing system nervousness.

In summary, the bullwhip effect, inventory variance, and system nervousness are all associated with forecasting. This thesis will investigate forecasting from a supply chain dynamics point of view based on three criteria: the bullwhip effect (or called the Forrester Effect), net stock amplification which is related to inventory variance, and system nervousness. Figure 1.2 illustrates the focus of the thesis. Particular emphasis is placed on the topics highlighted in bold.

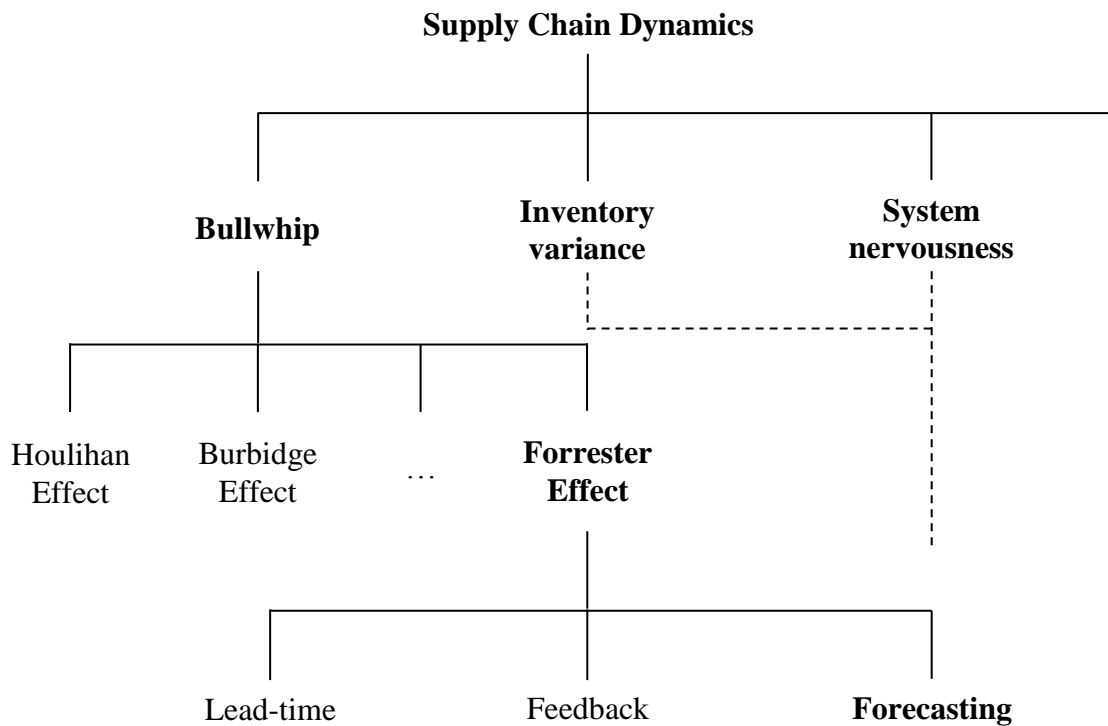

*Figure 1.2 Focus of the thesis*

## 1.2 Research questions

Two main gaps in the literature have been identified. The first one concerns the Damped Trend forecasting in supply chains. Although the Damped Trend forecasting has been recognised as “a benchmark forecasting method for all others to beat” (Fildes et al., 2008), there has been very little research, theory, or practice in supply chains concerned with the Damped Trend method. The second one recognises the co-existence of the MRP system nervousness problem and the bullwhip effect in the supply chain which has not been considered before in the literature. There is also no research to date concerned with how to forecast orders accurately in order to reduce system nervousness.

Therefore, this thesis will focus on two theoretical areas existing within the field of supply chain dynamics. The following research questions have been formulated and will be answered by this thesis:

Q1: Is Damped Trend forecasting superior to other methods from a supply chain dynamics perspective? This leads to the following sub-questions:

Q1a) What are the stability conditions of Damped Trend method from a control theory perspective?

Q1b) How do we integrate Damped Trend forecasts into the Order-Up-To policy?

Q1c) How do we measure the bullwhip effect and net stock amplification for non-stationary demand processes?

Q1d) What are the consequences of using DT forecasts on the supply chain metrics such as bullwhip and net stock amplification?

Q2: Can the system nervousness and the bullwhip in the supply chain be simultaneously reduced, without the disclosure of end consumer demand information? This also leads to a set of sub-questions:

Q2a) How should we forecast orders?

Q2b) Is the proportional controller able to reduce the nervousness of the system?

Q2c) How do future orders and order call-offs affect the orders and inventory levels in a supply chain?

### 1.3 Thesis structure

Figure 1.3 illustrates a brief overview of the structure of the thesis and the connections between the chapters and the research questions. The thesis is organised into eight chapters and the contents can be summarised as shown in Figure 1.3.

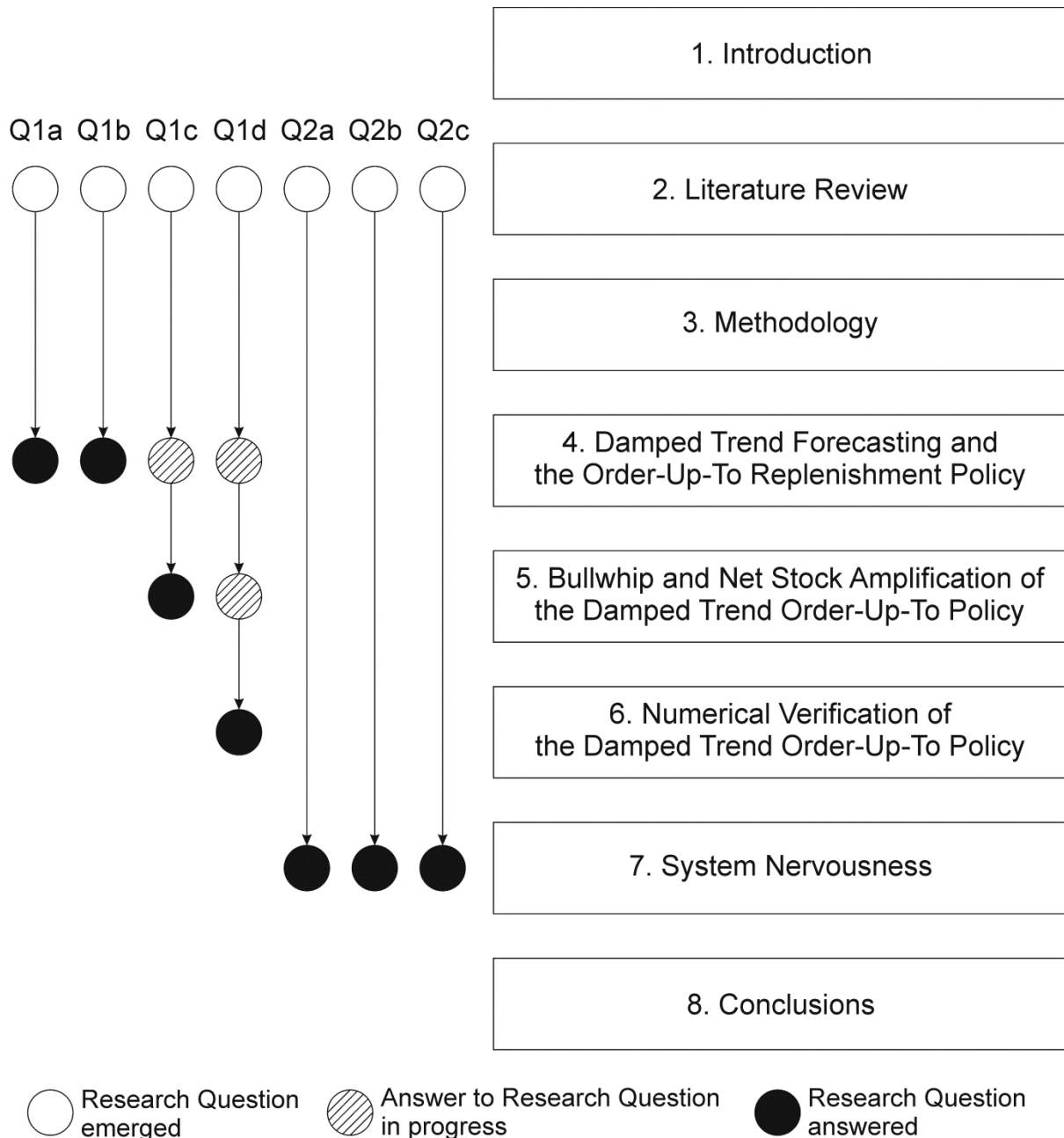

Figure 1.3 Thesis structure

**Chapter 1** has presented the background of the research and the initial motivation. Existing gaps in the literature were briefly introduced and research questions were stated.

**Chapter 2** reviews the literature to provide an overview of the previous research undertaken into the themes of the thesis: supply chain dynamics, forecasting, and nervousness. Research gaps and questions are also identified in this chapter.

**Chapter 3** outlines the philosophical stance of the thesis, critically discusses the potential research methods that might be applied, and briefly explains the research strategy.

**Chapter 4** first introduces the discrete time transfer function of the Damped Trend forecasting method. Then it answers the research questions Q1a and Q1b, by revisiting the stability conditions of the Damped Trend technique from the control theory perspective and integrating the Damped Trend forecasts into the Order-Up-To replenishment policy. A discrete time  $z$ -transform transfer function representation of the combined system is also built.

**Chapter 5** proposes a new metric of the bullwhip effect and net stock amplification for non-stationary demand processes and answers research question Q1c. The bullwhip performances of three special cases in the Damped Trend method (namely Naïve, simple exponential smoothing, and Holt's linear trend) are also studied. The frequency response plot of the Damped Trend forecasts within the OUT policy is explored. Later, the variance of the inventory levels maintained by the DT / OUT system is studied. In this chapter some analytical results that address the research question Q1d are provided.

**Chapter 6** further explores the necessary conditions for bullwhip and net stock amplification found in the previous chapter, and uses numerical simulation to verify the analytical results. Real-life demand patterns are also used to verify the results and provide the answer to research question Q1d.

**Chapter 7** describes three different scenarios for generating orders and order forecasts based upon the OUT policy in MRP systems. It also shows how to measure nervousness and quantifies the accuracy of the future guidance in each scenario. The chapter answers the research question Q2b by comparing the nervousness generated from the proportional controller with the nervousness generated by the conventional method. The research question Q2a is then answered by proposing a new proportional method for order forecasting. Finally, the answers to Q2c are investigated in the chapter.

**Chapter 8** collates the findings from the analytical and simulation studies to summarise the answers to the research questions. The limitations and potential lines for future research are also discussed in this chapter.

## **1.4 Definitions**

For clarification, this chapter ends by summarising some of the key terms used in this thesis.

**Supply chain** in this thesis a supply chain is considered to be either different functional units in the same organisation or a number of different organisations, working together to deliver products / service to customers. In the literature of supply chain collaboration, the former is called intra-organisation supply chain, the latter is inter-organisation supply chain.

**Production and inventory control** is a fundamental issue in supply chains. It could be identified as a single echelon problem, but has implications for multi-echelon supply chains. For example, an Order-Up-To policy is normally considered to be a single echelon system. One of the outputs is usually called “order quantity”. If we are talking about intra-organisation supply chains, the order quantity could refer to the production instruction to the production department. If we are considering an inter-organisation supply chain, the output

could be the replenishment order given to the supplier. It is well-known that the variability in the orders is costly in supply chains because of the bullwhip effect. Therefore, supply chain issues can still be investigated based on a single echelon production and inventory control system.

**Forecasting** has different meanings in the thesis. One is the traditional demand forecasting, using statistical methods like moving average, simple exponential smoothing, Damped Trend forecasting to estimate customer demand. Production and inventory control policies often use forecasts of demand as part of the decision making process that generates replenishment orders. Another forecasting issue is concerned with predicting the future order quantity that will be explicitly explored in Chapter 7. Order forecasting is directly linked to production planning and control. In terms of production planning and control, the frequent change of order forecasts causes the MRP system nervousness problem.

**Supply chain dynamics:** sometimes considered to be synonymous to the bullwhip effect in the literature. However, in this thesis, the term is used to indicate the dynamic behaviour in the supply chain, including capacity concerns (the bullwhip effect), inventory considerations (net stock amplification), and production issues (system nervousness).

**Net stock amplification** or more specifically net stock variance amplification, refers to how the variance of inventory level is amplified throughout the supply chain. It is important as the inventory variance produces inventory holding and backlog costs and has an immediate effect on customer service metrics such as availability and fill rates.



## **2. Literature Review**

To set the stage, this chapter will present an overview of previous studies related to the themes of this thesis: inventory control, bullwhip, information sharing, forecasting, and system nervousness. This review will also identify the gaps in the literature that led to the research questions stated in the previous chapter.

This chapter has three streams of management theories and practices. Section 2.1 will focus on supply chain dynamics starting with a series of issues related to inventory control which will be briefly discussed in 2.1.1. Next, attention will be given to the issue of the bullwhip effect. Section 2.1.3 will review the literature of information sharing, not only because it is efficient in terms of reducing the bullwhip, but also because of the importance to the system nervousness problem in section 2.3. Section 2.2 will consider an important question essential to many management decisions – forecasting. Several forecasting methods will be introduced in section 2.2.1, 2.2.2, and 2.2.3, including the Damped Trend forecasting method, the main instrument analysed in Chapter 4, 5, and 6. Section 2.2.4 will discuss the relationship between demand forecasting and supply chain research, and will identify the research gap – there is no research investigating the performance of Damped Trend forecasting when used in supply chain replenishment systems. Later, attention will be given to the topic of order forecasting in 2.2.5, followed by a discussion of the system nervousness problem in section 2.3. Then we note that both the bullwhip effect and the nervousness co-exist when there is no demand information sharing in supply chains. Section 2.4 will summarise and highlight the research gaps identified by the literature review.

## **2.1 Supply Chain Dynamics**

### **2.1.1 Inventory control**

Despite the fact that there are debates on the definition of supply chain management (Lambert and Cooper, 2000; Simchi-Levi et al., 2000; Mentzer et al., 2001) and on its difference with logistics management (Cooper et al., 1997; Lummus et al., 2001; Mentzer et al., 2001), one fundamental problem frequently encountered in these fields is how to determine the quantity to order from a supplier (or produce in a factory) that enables the supply chain to satisfy customers' demand without excessive inventory and capacity costs. It is known as production and inventory control problem.

There are many reasons for business to hold inventory. First of all, inventory is a buffer to provide customers products with an enhanced customer service level. Supply chain players must hold enough inventory to cover forecast errors over the production and distribution lead-time. Otherwise, customers usually will shop elsewhere if there are no stock or backlogs in store. Secondly, organisations use inventory as a buffer in production systems to absorb short term fluctuations in customer demand. This allows the production system to work to a level schedule. It is particularly useful as constantly changing production levels are costly. There are also other benefits of holding an inventory, such as hedging against inflation and other forms of price increases, taking advantage of quantity discounts, and decoupling production processes from unreliable supply.

On the other hand, there are also a number of good reasons not to hold inventories. Bonney (1994) addresses the opportunity cost associated with money tied up in inventory that could be used in a more productive manner, the costs of storage space, and the costs associated with managing the inventory. There are also less obvious costs associated with inventory, such as obsolescence and deterioration costs.

Grunwald and Fortuin (1992) assert that there is a complicated balancing act to consider when managing inventory – the goal is to maintain a minimum reasonable inventory so as to simultaneously reduce holding costs whilst maintaining customer service levels and buffering production from the variability in demand.

Among the alternative production planning and inventory control policies available, the order-up-to (OUT) policy is a popular policy as is not restricted to particular demand patterns (Dejonckheere et al., 2003). This suggests that the OUT policy would be suitable when demand contains significant trends. The OUT policy is a standard ordering algorithm in many MRP systems, used to balance the customer service, inventory, and capacity trade-off (Gilbert, 2005). At discrete points in time (i.e. every day, week, month), the current inventory position is reviewed and an order is placed to restore the inventory position back to the order-up-to level,  $S$ . The order decision is based on the forecast for the period after the lead-time, the forecast of the demand during the lead-time, the current inventory levels, the current work-in-progress levels and a safety stock level. Note that the OUT policy is also the periodic  $(s, S)$  policy when  $s = S$  (Axsäter, 2006).

A minimised inventory variance leads to reduce safety stock requirements in supply chains (and lower inventory costs) in order to meet availability targets when constant lead-times exist (Disney and Lambrecht, 2007). However, most OUT policy settings result in a phenomenon where the variance of orders is greater than the variance of the demand. That means a bullwhip effect is produced. It has been shown that the bullwhip effect in the OUT system is related to the variance of forecasts as well as the variance of the forecast errors of demand over the lead-time and review period (Chen et al., 2000b; Dejonckheere et al., 2003).

Since Towill (1982) introduced the original concept of the inventory and order based production control system (IOBPCS model), a number of researchers have extended the

IOBPCS into a range of models (Wilson, 2007; Aggelogiannaki et al., 2008; Eshlaghy and Razavi, 2011). There are a lot of similarities between the IOBPCS family and the OUT policy. They both consider demand forecasts, inventory and work-in-progress, but these elements are sometimes treated differently.

For example, in one variant of IOBPCS called the Automatic Pipeline Inventory and Order Based Production Control Systems (APIOBPCS) (John et al., 1994), two control parameters ( $T_i$  and  $T_w$ ) are added to tune the rate at which discrepancies between target and actual inventory and work-in-progress levels are accounted for. These “feedback controllers” provide flexibility to shape the dynamic response and to alter the inventory availability and capacity trade-off. Naim and Towill (1995) show that the APIOBPCS model is also equivalent to Serman’s (1989) Beer Game anchoring and adjustment heuristic. By the appropriate selection of system parameters, the model can cover different supply chain philosophies ranging from make-to-stock to make-to-order.

Interestingly, if we consider  $T_i = T_w = 1$ , the APIOBPCS model degenerates into the OUT policy. If we assume  $T_i = T_w$ , the model is equivalent to the so-called Proportional OUT (POUT) policy (Dejonckheere et al., 2003). Both the APIOBPCS and POUT policy have the ability to eliminate the bullwhip effect that is difficult to avoid by the OUT policy. However, both the APIOBPCS and the POUT policy require modifications to the OUT policy.

### **2.1.2 Bullwhip effect**

The bullwhip effect is a common phenomenon in supply chain, referring to the scenario where demand fluctuations are amplified upstream from customers to suppliers (Lee et al., 1997a, b). It is costly in supply chains as it creates costs either in the form of labour idling

and over-time or excessive and unused capacity. The bullwhip effect also can amplify the volatility introduced by the economic environment (Aeppel, 2010; Cannella et al., 2014). Evidence of the bullwhip effect was found in monthly inventory and sales data in the U.S. manufacturers when Dooley et al. (2010) studied the impact of the recession on manufacturers, wholesalers, and retailers.

Forrester (1958) shows that this demand variance amplification is caused by the structure of replenishment policies as each player in the supply chain is trying to react to individual demand signals. Lee et al. (1997a, b) further categorise five major operational causes of bullwhip: demand signal processing, lead-time, order batching, price fluctuations, and rationing and shortage gaming. Some scholars suggest that behavioural aspects also cause bullwhip (Sterman, 1989; Croson and Donohue, 2002, 2006). For example, decision makers do not have a clear idea of what is available in the supply chain, which leads to decision bias. We refer to Geary et al.'s (2006) comprehensive review for more causes of the bullwhip effect.

One of the well-known management games to understand the bullwhip effect and supply chain inventory problems is the Beer Game (Sterman, 1989). The game illustrates a typical four-tier beer distribution supply chain, where the players (factory, distributor, wholesaler, and retailer) are managing each tier, enacting and re-enacting the process of ordering beer through the supply chain. The Beer Game represents many supply chains in the real world and has been used in many bullwhip related studies (Croson and Donohue, 2003, 2006; Disney et al., 2004). By studying how people react during the game, it yields valuable anecdotal evidence. However, the game is limited in the sense that nothing can be mathematically proved. Therefore, researchers have attempted to gain an in-depth understanding from the game by developing simulation models allowing players to test out

strategies and inventory control models (Van Ackere et al., 1993; Mason-Jones and Towill, 1997; Mason-Jones et al., 1997; Hong-Ming et al., 2000; Coppini et al., 2010).

There is a large and growing literature on the bullwhip effect, using statistical and operational research methods, control theory, system dynamics and simulation. Lee et al. (2000) investigated the impact of autocorrelation in the demand, and found that information sharing reduces the manufacturer's inventory costs. Chen et al. (2000a) quantified the impact of different forecasting mechanisms and lead-times on the bullwhip effect in a two-echelon supply chain where a centralised demand information strategy is applied. Daganzo (2004) focused on the relative value of information of past demand on the bullwhip effect. Dejonckheere et al. (2003) use  $z$ -transforms to investigate the bullwhip effect induced by common forecasting methods such as moving averages, simple exponential smoothing when they are used in the OUT policy. Disney and Lambrecht (2007) further summarise the use of transforms and their properties related to bullwhip studies.

Disney and Towill (2003) deduce the equations for bullwhip in discrete time when the customer demand is drawn from an independent and identically distributed (i.i.d.) random series:

$$Bullwhip = \frac{\sigma_o^2}{\sigma_d^2} = \sum_{n=0}^{\infty} [f_o(n)]^2 \quad (2.1)$$

where  $f_o(n)$  is the time domain solution to the difference equations for the impulse response of the order rate. When demand is not restricted to i.i.d., for example when the demand process is known and ergodic, Ouyang and Daganzo (2006) use the worst-case root mean squared errors ratio to judge whether or not there is the bullwhip effect in an H-infinity analysis. Gaalman and Disney (2012) introduce an alternative way to characterise the bullwhip effect instead of using the variance ratio. When  $\sigma_o^2 - \sigma_d^2 > 0$ , a bullwhip effect exists,

when  $\sigma_o^2 - \sigma_d^2 \leq 0$ , the bullwhip effect is avoided. However, it is still not able to completely characterise the bullwhip effect for non-stationary series.

The studies on bullwhip effect are not restricted to a two-echelon supply chain or a single product. Chatfield et al. (2004) simulated a customer-retailer-wholesaler-distributor-factory supply chain. They examined the effects of several factors (i.e. stochastic lead times, information sharing, and the quality of that information) on the bullwhip in a periodic OUT inventory system. Bottani et al. (2010) assessed the impact of Radio Frequency Identification technology and the Electronic Product Code network on the bullwhip effect in a three-echelon Italian Fast Moving Consumer Goods (FMCG) supply chain. Boute et al. (2012) considered a multi-product setting where demands of each product are inter-dependent with each other and over time, and analysed the impact on both production and inventory related costs. Similar research of multi-product or multi-echelon supply chains can also be found in the literature, see Torres and Maltz (2010), Wangphanich et al. (2010), Hussain et al. (2012).

Most recently, the bullwhip effect has been observed in the service industry as well. Akkermans and Voss (2013) found empirical evidence showing the presence of a service bullwhip effect in a European telephone company. A sudden increase of 36% in sales caused a 60% uplift in customer calls and a dramatic 130% increase in customer complaints. The lag from the surge in sales to the maximum amplification of customer complaints was 13 months. Lin et al. (2014) studied the bullwhip effect in a hybrid supply chain formed by a group of manufacturers and service providers who work together to offer total solutions to customers. Similar early observations were also documented in Akkermans and Vos (2003), Anderson et al. (2005).

A number of suggestions have been proposed to mitigate the bullwhip effect. It is generally believed that centralised inventory control like Distribution Requirements Planning (DRP)

and Vendor Managed Inventory (VMI) are superior to decentralised control in terms of improving supply chain performance. Time compression techniques such as supplier hubs, logistics integrators, direct channels, web-enabled communication, EDI, e-procurement and so on, can eliminate or reduce the lead-time, leading to less inventory and less bullwhip. In addition, Towill (1994) suggests that the proper design of feedback loops is able to improve the information flow across organisational boundaries. Burbidge (1996) discusses the problems caused by order batching and studies a range of practical solutions that date as far back as the 1960s. Moreover, by improving the transparency of physical and information flow in the supply chain, the problem of the bullwhip effect can also be relieved. Such techniques have been emphasised for decades in the presence of information sharing and collaborations. Through the collaborative planning process with one of its customers, Philips Semiconductors have saved around US\$5 million every year by eliminating the bullwhip effect (De Kok et al., 2005).

### **2.1.3 Information sharing**

There are many different definitions of information sharing in supply chain, see Table 2.1. For example, Mentzer et al.'s (2001) definition refers to sharing strategic and tactical data, whereas Wadhwa and Saxena (2007) argue that the shared information need not be only data, but could also include knowledge.

Indeed, from the definitions in the literature, it is easy to notice there are various types of information that could be shared in a supply chain. There are customer demand, point-of-sale (POS), order information, inventory status, and delivery schedules on the operational level. Production plans, forecasts, capacity on the tactical level can also be shared through supply chains. On the strategic level, it is recommended to share information concerning long-term



supply chain strategies, market trends, and capacity for growth for example Mohr and Spekman (1994).

<b>Authors (year)</b>	<b>Definition</b>
Mohr and Spekman (1994)	The extent to which critical, often proprietary, information is communicated to one's partner.
Mentzer et al. (2001)	The willingness to make strategic and tactical data available to other members of the supply chain.
Hsu et al. (2008)	The extent to which crucial and/or proprietary information on the tactical and strategic level is available to members of the supply chain.
Cao et al. (2010)	The extent to which a firm shares a variety of relevant, accurate, complete and confidential ideas, plans, and procedures with its supply chain partners in a timely manner.

*Table 2.1 Definitions for information sharing*

Extensive theoretical and empirical studies in the literature have highlighted that information sharing can help companies achieve a number of benefits in forecasting, inventory, production, logistics, product and process management, risk management, financial performance, and supply chain performance (Mentzer et al., 2001; Sahin and Robinson, 2002).

For example, Cachon and Fisher (2000) integrate information sharing into inventory management policies when demands are independent and identically distributed (i.i.d.), and find substantial savings from lead-time and batch size reduction attributed to sharing demand and inventory data. Lee et al. (2000) quantify the benefits of information sharing in a two-echelon supply chain using OUT policy and AR(1) demand, and show that the manufacturer can obtain inventory and cost reduction especially when demand is highly positively

correlated over time, highly variable, and there is a long lead-time. Li et al. (2006) examine five information sharing strategies in a linear n-echelon supply chain that applies the OUT policy at each stage under i.i.d. end consumer demand. They find information sharing helps to counter the bullwhip effect caused by the time lag in the supply chain. Demand information sharing is more efficient than the sharing of inventory data and shipment data in terms of inventory costs and fill rate. The impact of information sharing largely depends on the demand pattern and the structure of the supply chain.

Based on the samples collected from UK manufacturers and service providers, Frohlich and Westbrook (2002) find that companies who rely on web-based demand or supply chain integration outperform those who do not, and manufacturers who deployed demand chain management have the highest performance. Huo et al. (2014) use data from 617 Chinese manufacturing firms to investigate the effectiveness of supply chain information sharing on the performance measures such as responsiveness to customer needs, speed of the supply chain process, delivery performance, and customer service level. Although they found supply chain performances are positively correlated to information sharing in Chinese companies with an international competitor, Chinese companies facing only local competition were not very interested in sharing information both internally and externally.

Information sharing in reality is limited for various reasons. The task of determining what information should be shared and with whom is complex, especially when information sharing may involve several different partners (Samaddar et al., 2006). There are concerns about costs (Uzzi and Lancaster, 2003), and disappointment by the returns of information sharing applications (Vanpoucke et al., 2009; Ganesh et al., 2014). Some companies are afraid of potentially losing power and competitiveness (Uzzi and Lancaster, 2003). Finally, there is a concern of how to allocate the benefits from information sharing in supply chains (Lee and Whang, 2000). Zhao et al. (2008, 2011) assert that the integration of data and

systems in a supply chain is not easy, and integration between different companies does not only depend on information system capabilities but also on the trust and relationship commitment between the players in a supply chain.

## **2.2 Forecasting**

Proper forecasting is a prerequisite to production and inventory management activities. Hendry and Kingsman (1989) advocate that balancing supply and demand begins with making accurate forecasts. Traditionally, forecasting methods are either based on mathematical models that use available historical data, or on qualitative methods that draw on managerial experience and judgments. They may also be based on a combination of both, where quantitative forecasts generated by a forecasting system are manually adjusted based on human judgement.

There is a large body of research on forecasting in the literature, but there is little agreement on the most accurate forecasting approach (Fildes, 1979; Gardner, 2006). However, exponential smoothing and ARIMA models (Box et al., 2008) are popular forecasting techniques in the supply chain management field (Armstrong and Fildes, 2006; Gardner, 1985, 2006), with little difference in forecast accuracy between them (Makridakis and Hibon, 1979; Makridakis et al., 1982).

We will now review some of the forecasting techniques and issues considered in this thesis.

### 2.2.1 Simple exponential smoothing

Since the original work by Brown and Holt in the 1950s, simple exponential smoothing (SES) has been recommended as a good choice for short-term forecasting (Makridakis et al., 1982). The popularity of the method is due to its simplicity, intuition, small computational effort and ease of application. Although there is little difference in forecast accuracy between exponential smoothing and ARIMA methods, exponential smoothing requires less effort in model identification than ARIMA does. Minimised mean squared error (MMSE) during the model fitting phase does not guarantee MMSE in the post-sample phase simply because real-life data are often structurally unstable. ARIMA model is sensitive to selection errors. Exponential smoothing methods, such as SES, on the other hand, are fairly robust. They are generally insensitive to specification errors, and are fairly responsive to the non-stationary, unstable, and non-linear world in which we live. Therefore, the robustness of exponential smoothing may explain the popularity of exponential smoothing in practical settings.

Simple exponential smoothing forecasts are generated by:

$$\left. \begin{aligned} \hat{a}_t &= (1-\alpha)\hat{a}_{t-1} + \alpha d_t \\ \hat{d}_{t,t+k} &= \hat{a}_t \end{aligned} \right\} \quad (2.2)$$

where  $d_t$  is the observed demand at time  $t$ ;  $\hat{a}_t$  is the current estimate of the level, exponentially smoothed by the parameter  $\alpha$ ;  $\hat{d}_{t,t+k}$  is the  $k$ -step ahead forecast, made at time  $t$ , of the demand in the period  $t+k$ . Note that all  $k$ -step ahead forecasts are the same  $\hat{a}_t$  with SES.

### 2.2.2 Holt's method

Simple exponential smoothing is an appropriate method for forecasting a demand pattern with a constant mean. Holt developed a linear trend forecasting system for when there is a trend in the time series. It is defined by the following system of difference equations,

$$\left. \begin{aligned} \hat{a}_t &= (1-\alpha)\hat{a}_{t-1} + \alpha d_t \\ \hat{b}_t &= (1-\beta)\hat{b}_{t-1} + \beta(\hat{a}_t - \hat{a}_{t-1}) \\ \hat{d}_{t,t+k} &= \hat{a}_t + k\hat{b}_t \end{aligned} \right\} \quad (2.3)$$

Here  $\hat{b}_t$  is the estimate of the local trend smoothed by another parameter  $\beta$ . The linear trend model generates future forecasts that change over time, and can be used over any forecasting horizon. This method uses separate parameters to smooth the level and trend, but Brown's double exponential smoothing uses a single parameter to smooth both components, by setting  $\beta = 1 - \alpha$ . This can be considered a special case of Holt's method.

The literature has proved the optimality of both methods for a random walk with a linear growth as well as ARIMA(0,2,2) process (Harrison, 1967; Harvey, 1984). But when other processes are involved, empirical studies (Makridakis and Hibon, 1979; Makridakis et al., 1982) suggest Holt's method is more accurate than Brown's method. Whilst the Brown's method extrapolates some trends from the demand series, the two-parameter Holt's model offers additional flexibility. However, both models have a tendency to overshoot the data when they are producing more than three or four periods ahead forecasts.

### 2.2.3 Damped trend method

To overcome the drawback of the linear trend model, Lewandowski (1982), Makridakis et al. (1982), and Gardner and McKenzie (1985) argue that the trend should be damped over time.

By modifying Holt's linear trend method, Gardner and McKenzie (1985) developed the damped trend (DT) forecasting technique given by

$$\left. \begin{aligned} \hat{a}_t &= (1-\alpha)(\hat{a}_{t-1} + \phi\hat{b}_{t-1}) + \alpha d_t \\ \hat{b}_t &= (1-\beta)\phi\hat{b}_{t-1} + \beta(\hat{a}_t - \hat{a}_{t-1}) \\ \hat{d}_{t,t+k} &= \hat{a}_t + \hat{b}_t\gamma(k, \phi) \end{aligned} \right\}. \quad (2.4)$$

The first equation of (2.4) shows that the estimated demand consists of a time dependant "level" component, the second equation tracks a trend component and the third equation combines the level and trend estimates to make a  $k$ -period ahead forecast.

In the linear discrete time difference equation of (2.4),  $\phi$  is a damping parameter that can be interpreted as a measure of the persistence of the trend, and  $\gamma(k, \phi) = \sum_{i=1}^k \phi^i = \phi(\phi^k - 1)/(\phi - 1)$  extrapolates the trend out  $k$  periods in to the future. The behaviour of  $\gamma(k, \phi)$  is quite rich. When  $\phi > 1$  then  $\gamma(k, \phi)$  exhibits positive exponential growth over  $k$ .  $\phi = 1$  implies a  $\gamma(k, \phi)$  with positive linear growth over  $k$ .  $0 < \phi < 1$  produces a positive damped exponential growth that approaches  $\phi/(1-\phi)$  as  $k \rightarrow \infty$ . When  $\phi = 0$  then  $\gamma(k, \phi) = 0$ . When  $-1 < \phi < 0$ ,  $\gamma(k, \phi)$  has a two period oscillation that is always negative and converges to  $\phi/(1-\phi)$ .  $\phi < -1$  results in a  $\gamma(k, \phi)$  with a two period oscillation that alternates between positive and negative numbers with ever increasing amplitude over  $k$ .

Although such exponential smoothing systems with damping parameters had been noted earlier (see for instance, Gilchrist (1976), Roberts (1982), and Gardner (1985)), Gardner and McKenzie (1985) were the first to present both a theoretical and an empirical investigation of the system. Since then, the DT method has been promoted as the most accurate forecasting technique in the so-called M-competitions (Makridakis and Hibon, 2000). It is the best method for 84% of the 3003 time series in the M3 forecasting competition when using local

initial values, and the best method 70% of the time when using global initial values (Gardner and McKenzie, 2011). Fildes et al. (2008) concluded that the DT forecasting can “reasonably claim to be a benchmark forecasting method for all others to beat”.

Compared to models which assume a linear trend, the model proposed improves long-term forecast accuracy without any apparent cost in short-term performance, no matter whether the trend is erratic or persistent. The great virtue of the DT forecasting methodology is that future predictions are not simply the flat line extensions of the current (next period) forecast. It is able to detect and forecast both linear and exponential trends.

The DT forecasting methodology also contains at least eleven different forecasting methods when all of the three parameters are selected from the real  $[0,1]$  interval (Gardner and McKenzie, 2011). This makes it a powerful and very general approach for short term demand forecasting as tuning the DT parameters effectively automates model selection. These include the Holts method when  $\phi = 1$  where there is no damping of the trend component, Simple Exponential Smoothing (SES) when  $\phi = 0$  and  $\beta = 0$ , and Naïve forecasting when  $\phi = 0$ ,  $\alpha = 1$  and  $\beta = 0$ .

A series of papers (Gardner, 1985, 1990; Gardner and McKenzie, 1985, 1989) have proposed restricting the damping parameter to the  $[0,1]$  interval, and that the rate of decay  $(1-\phi)$  increases with the noise in the series because the difference between a damped and a linear trend can be substantial over long time horizons. When  $\phi > 1$ , both Gardner (1985) and Gardner and McKenzie (1985) explain that the forecast exhibits an exponential growth over time and is probably a dangerous option to use in an automatic forecasting procedure. However, both Tashman and Kruk (1996) and Taylor (2003) argue that there can be value in allowing  $\phi > 1$  as it could be suited to time series with strong increasing trends. Roberts

(1982) mentions that a negative  $\phi$  is possible, but generally negative damping parameters are not discussed in the literature. In addition, the DT method is equivalent to the ARIMA(1,1,2) process, where parameters less than 0 and greater than 1 are a readily accepted and established part of the literature.

#### 2.2.4 ARIMA models

The Autoregressive Integrated Moving Average model (ARIMA( $p,d,q$ )) is a time series approach (Box et al., 2008) that can yield valuable statistical characteristics of a system. This method is very useful for model building, identification, and fitting. It is related to control theory to some extent, in that both approaches operate in discrete time and both discrete approaches use delay operators.

An ARIMA( $p,d,q$ ) model of a time series  $X_t$  is given by:

$$\left(1 - \sum_{i=1}^p \phi_i B^i\right) (1-B)^d (X_t) = \left(1 - \sum_{i=1}^q \theta_i B^i\right) \varepsilon_t, \quad (2.5)$$

where  $\varepsilon_t$  is a time series of independent identically distributed random variables – the noise series.  $B$  is the backshift operator:  $BX_t = X_{t-1}$  hence  $B^n X_t = X_{t-n}$ ;  $p$  is the number of autoregressive terms;  $q$  is the number of moving average terms. (2.5) can also be written as

$$\phi(B) \nabla^d X_t = \theta(B) \varepsilon_t, \quad (2.6)$$

where

$$\begin{aligned} \phi(B) &= 1 - \sum_{i=1}^p \phi_i B^i = 1 - \phi_1 B - \phi_2 B^2 - \dots - \phi_p B^p, \\ \theta(B) &= 1 - \sum_{i=1}^q \theta_i B^i = 1 - \theta_1 B - \theta_2 B^2 - \dots - \theta_q B^q, \\ \nabla &= 1 - B; \end{aligned} \quad (2.7)$$



or

$$\varphi(B)X_t = \theta(B)\varepsilon_t \quad (2.8)$$

where  $\varphi(B) = \phi(B)\nabla^d$  is a polynomial of order  $p + d$ .

The ARIMA model is a generalisation of a time series which makes it a useful forecasting technique. For instance, simple exponential smoothing is equivalent to the ARIMA(0,1,1) model, the ARIMA(0,2,2) model represents the Holt's linear trend model, and the DT method is equivalent to the ARIMA(1,1,2) model. Aburto and Weber (2007) designed a replenishment system as a mixed system combining an ARIMA model with a neural network, which lead to more accurate forecasts, fewer lost sales and lower inventory level. Wang et al. (2010) showed that the adoption of ARIMA forecasting in addition to RFID can effectively improve the performance of forecasting and inventory management in their case study.

In the literature of supply chain research, ARIMA models are also used to represent demand. The bullwhip effect on the AR(1) demand process has been studied by Chen et al. (2000a), Kahn (1987), Lee et al. (1997a). Gaalman and Disney (2006) investigated the bullwhip effect produced by OUT policy reacting to the ARMA(1,1) demand process. Gaalman (2006) studied the POUT system under general ARMA( $p,q$ ) demand and compared it with the so-called full-state-feedback OUT policy. Gaalman and Disney (2009) analysed the dynamic behaviour of POUT system for ARMA(2,2) demand. Babai et al. (2013) examined the relationship between forecasting accuracy and inventory performance and the benefits of forecast information sharing in empirical inventory systems with ARIMA(0,1,1) demand. The amplification in order variance and inventory variance has been quantified by Disney et al. (2006) under a generalised OUT policy for i.i.d., AR, MA, and ARMA demand processes. Gilbert (2005) demonstrated that given an ARIMA demand model, the orders and inventories at each stage in a supply chain are also ARIMA.

### **2.2.5 Demand forecasting and supply chain research**

Armstrong (1986) argued that the choice of forecasting method appears to have no important influence on inventory investment and customer service, because of the little difference in forecast accuracy. However, if we look beyond the single indicator – accuracy, for example, Gardner (1990) considers that some other measures could be more meaningful to managers such as total variable costs associated with ordering cost, holding cost, and backlog cost. He demonstrates that the choice of forecasting mechanism is an important factor in inventory management. As Makridakis et al. (1983) suggested more than 30 years ago: “while there undoubtedly will be some improvements in available methodologies, it is management’s knowledge and use of existing methods, in their specific organizational context, that hold the greatest promise”. He had predicted that great gains would be made in the area of implementation and practice.

Demand forecasting is also considered to be one of the key causes of the bullwhip effect. Dejonckheere et al. (2003) study the Naïve, simple exponential smoothing, and moving average forecasting techniques in the OUT policy, and find these forecasting systems always produce bullwhip, but their conjecture was not formally proved. Similar results can also be found in Zhang (2004) where the impact of several forecasting methods such as the minimised mean squared error (MMSE) forecasting, moving average, and simple exponential smoothing on the bullwhip effect in the OUT policy are investigated.

Although the DT method is claimed to be superior to many other methods from a forecasting perspective, only a few studies are available that demonstrate the managerial importance of DT forecasting in the supply chain, inventory or operations management fields. Snyder et al. (2002) study the exponential smoothing family of forecasting methods (including Damped

Trend) in the Order-Up-To inventory control policy. They use a bootstrap method to determine the total lead-time demand distribution and measure performance via the fill rate. Acar and Gardner (2012) investigate the use of the DT method in a real supply chain based on the trade-offs recommended by Gardner (1990) and show that the DT method outperforms simple exponential smoothing and the Holts method. Still, no research to date considers the impact of DT forecasting technique on supply chain dynamics and the bullwhip problem. Considering the fact that the performance of some special cases of DT method on supply chain dynamics are already well known, the DT method should at least achieve the same bullwhip performance as its special cases. It would be interesting to understand, however, if superior performance can be obtained.

### **2.2.6 Order forecasting**

Order forecasting is an under researched area, because the orders in a supply chain frequently have even more variability than consumer demand, making them difficult to forecast, due to the bullwhip effect. When the forecasts of future orders are inaccurate, the supply chain can suffer from stock outs or excessive inventory, as well as instability in production scheduling. This effect is known as system nervousness.

As there seems to be a long-run equilibrium between sales and orders (Granger and Lee, 1989), recent research has concentrated on forecasting orders based on point-of-sales (POS) data. From a case study in high-technology consumer durables, Hanssens (1998) find the evidence of a long-run equilibrium relationship between retailer's orders and sales, both of which were non-stationary time series. He then demonstrates how marketing data and statistical methods can improve the accuracy of order forecasts. Lapide (1999) further

suggests that improvements in forecast accuracy may be achieved by sharing the historical order information and the POS data.

Williams and Waller (2010) argue that although POS is generally a better order forecast input than order data, there remains a large number of cases where order data is a better predictor than POS data. They have suggested that practitioners should not simply assume that either POS or order history is better. Williams et al. (2014) demonstrate that order forecasts can be generated through an inventory balance approach operationalised using vector error correction models when sales and orders are cointegrated. However, such an approach requires POS data, retailer's inventory information, and sophisticated data analysis. No studies to date have considered order forecasting when there is no demand information sharing in supply chains. Considering that practitioners may disregard using POS data when forecasting orders (Williams and Waller, 2010), information sharing is a complex task in reality, it may be helpful to develop alternative order forecasting techniques.

### **2.3 System Nervousness**

The essence of an MRP system is to exploit the dependence among bill of materials levels for projecting future requirements. When new, and presumably more accurate data, becomes available regarding the future requirements for the items being scheduled, a re-scheduling activity is undertaken. Carlson et al. (1979) suggest that the scheduling decisions should be based upon the best data available and it would be irrational to ignore new information. However, the frequent changing of schedules leads to MRP system nervous (Mather, 1977). This nervousness results in reduced productivity, increased costs, lower service level and confusion at the shop floor (Campbell, 1971; Hayes and Clark, 1985).

There are many causes of the rescheduling such as uncertainty in demand and/or in supply (Whybark and Williams, 1976). It is common that most demand deviates from the forecasts, therefore, leading to changes in the quantity or due time. Likewise, scrap losses, machine breakdowns, production overruns and shortfalls, variations in lead times may also lead to schedule changes. In addition, dynamic lot-sizing procedures are also believed to be the cause of nervousness (Steele, 1975; Mather, 1977).

In order to reduce nervousness, several approach have been adopted in the literature, including:

- *Freezing*: Zhao and Lee (1993) studied the order-based and period-based freezing methods in a multi-level system, and found that freezing techniques effectively reduce nervousness. This was also confirmed by Kadipasaoglu and Sridharan (1995) where they compared freezing, safety stock, and lot-for-lot scheduling in a multi-level MRP system. Nevertheless, the freezing technique is susceptible to demand uncertainty within the freezing horizon – another potential source of nervousness. For example, Zhao and Lee's (1993) results suggest that freezing may increase costs when demand is not known.
- *Forecasting beyond the planning horizon*: Carlson et al. (1982) used the combination of both known future demand and forecasted future demand to determine the lot-size in a single stage-system and found this method is valuable in certain situations. Blackburn et al. (1986) further proved the effectiveness of this approach in multi-stage systems. However, the value of this approach depends on the accuracy of forecasts and the demand variation.
- *Lot-sizing algorithms*: Despite the fact that dynamic scheduling algorithms inevitably induce nervousness, researchers have continued to investigate and improve the

performance of various lot-size algorithms. Departing from the basic, lot-for-lot EOQ strategy, to more advanced techniques like the Wagner-Whitin (1958) algorithm, Part-Period Balancing heuristic (Gorham, 1968), Silver-Meal (1973) and the Triple Algorithm (Grubbström, 2005) have been proposed. Ho and Ireland (1998) found that the effect of forecast errors on system nervousness could be neutralised by the appropriate selection of a lot-size or a given operating environment with a certain setup / carrying cost ratio. However forecast errors can have a large impact on the cost effectiveness of lot-sizing methods (De Bodt and van Wassenhove, 1983). In addition, it is difficult to communicate dynamic programming methods to many production schedulers and managers.

- *Change cost procedure*: Carlson et al. (1979) proposed a modified setup cost method. He added additional change costs, which depend on the previous schedule, into the objective function. This new objective function discouraged unscheduled setups and encouraged scheduled setups. Different lot-sizing algorithms were applied to optimise the balance of inventory cost, setup cost, and the cost of nervousness. It provided a balance between the cost of a nervous MRP system and the cost of a non-optimal schedule. Practitioners can choose solutions where the amount of nervousness is economically tolerable. The effectiveness of this approach was further explored and verified by Kropp et al. (1983), Kropp and Carlson (1984), Blackburn et al. (1986).
- *Buffering*: There are different types of buffer, i.e. safety stock, safety capacity, and safety lead-time. Grasso and Taylor (1984) assessed the impact of safety stock and safety lead-time on the total cost of MRP system given supply and timing uncertainty. They found that using safety stock is more prudent than using safety lead-time in their scenario. Schmitt (1984) showed that safety stock and safety capacity are more cost efficient than rescheduling. He also indicated that these two methods are more useful

as protection against time uncertainty than demand uncertainty because the reduction of operational costs could mitigate the influence of forecast errors. Under a wide range of operating conditions, Sridharan and LaForge (1989) indicate that a small amount of safety stock, in general, improves the stability in the production schedule, but increases in safety stock might induce schedule instability in some circumstances. Grubbström and Molinder (1996) calculated the optimal amount of safety stock and the optimised production plans with Poisson distributed demand. Buffering techniques are believed to be able to alleviate the symptoms of instability in the system, but they inevitably come at a cost of inventory investment and unused capacity.

- *Dampening procedure*: This technique filters “insignificant” rescheduling messages generated by the MRP system, therefore avoids the disruptions of open order priority (Peterson, 1975; Orlicky, 1976; Mather, 1977). Those “significant” rescheduling messages result in a revision to the due dates of open orders. Although this type of method is able to alleviate system nervousness by reducing rescheduling frequency of open orders, the performance depends on manufactures’ operating environment (Ho and Carter 1996; Ho 2005).

The accuracy of forecasting methods was once a major concern of production planning and control. However, with the development of materials requirement planning (MRP) systems, the significance of selecting appropriate forecasting method has diminished. This may be because MRP is believed to be able to cope with forecast errors by dynamically rescheduling the master production schedule (MPS). However, as we have discussed, this excessive rescheduling leads to MRP system nervousness.

The lack of research focussing on forecasting and nervousness might be reasonable. There is a considerable amount of literature on forecasting methods and their accuracy. On the face of it, we just need to apply the most accurate (or appropriate) forecasts to improve MRP

performance. However, this might be inappropriate because of the difference between order forecasts and demand forecasts. The demand received by manufacturers are the orders from their customers and these are often not the same as end consumer demand forecasts because of inventory management policies and other “demand signal processing” activities (Lee et al., 1997a).

Orders in a supply chain are frequently more volatile than consumer demand because of the bullwhip effect. This makes them difficult to forecast, and the lack of accurate order forecasts can have severe consequence on the supply chain, causing stock out or excessive inventory, as well as unstable production schedules. The issue is not to forecast demand but to forecast orders accurately. This returns us to the essence of the problem of nervousness from supply chain perspective – how do we produce valuable information for the supply chain?

## **2.4 Summary**

The superiority of Damped Trend forecasting has been extensively examined in the literature. Only a few studies have investigated its performance from a managerial perspective. Especially, in supply chains, there are plenty of metrics that measure the performance. Whilst it is known that other popular forecasting techniques used in production planning and inventory control systems often induce the bullwhip effect, there is no research to date that considers the impact of DT forecasting on supply chain dynamics. It would be interesting to investigate the performance of the Damped Trend forecasting method from a supply chain dynamics perspective.

This thesis integrates the Damped Trend forecasting methodology into the OUT policy, creating a system that is able to cope with both stationary and non-stationary demand. The



Damped Trend forecasting should be able to achieve at least the same level of performance as its special cases. However, it may also provide some additional forecasting flexibility when demand is non-stationary. Therefore, the thesis will first study forecasting techniques from a supply chain perspective, using the forecasts inside the Order-Up-To replenishment policy, and evaluate performance via the bullwhip criterion. This focus allows us to sharpen and refine the results of Dejonckheere et al. (2003) and to introduce new results for the Holts and Damped Trend forecasting methods.

Another research gap identified in the literature is the distressing situation that bullwhip effect and nervousness might exist simultaneously in supply chains. Without information sharing, suppliers can only use conventional forecasting methods to forecast the retailer's orders based upon the retailer's order history. This is very likely to produce the bullwhip effect. Because orders are more difficult to forecast when the bullwhip effect is present, it may create excessive rescheduling signals in MRP systems, resulting in nervousness.

When alternative information is available in supply chains, suppliers could forecast orders placed by retailers using the real consumer demand information (Lapide, 1999). The literature of order forecasting is mainly focused on utilising POS data. This might not be a desirable setting, not only because practitioners may disregard POS data in favour of order data when determining order forecasts, but also because information sharing is not always an option for technical and commercial reasons. Thus, it is worth to exploring alternatives when there is no information sharing in supply chains. From the practice of call-offs and order forecasts mentioned in Chapter 1, it is not difficult to notice the co-existence of the bullwhip effect and the nervousness. As the POUT policy is so useful that eliminating the bullwhip effect; we might also wonder whether or not it is able to reduce system nervousness. This thesis will investigate this question and propose a new method to generate the order forecasts that accounts for the future impact of the proportional controller.

In summary, the following gaps were identified in the literature review chapter:

- No research has currently been conducted on the Damped Trend forecasting method from a supply chain dynamics perspective.
- Current bullwhip metrics are not suitable for demand with significant trends.
- No research has yet considered the problem of the bullwhip effect and system nervousness together.
- There is a lack of research concerned with order forecasting when demand information is not shared throughout the supply chain.
- There is no established measurement of the nervousness caused by quantity changes in the MRP literature.

### 3. Methodology

The purpose of this chapter is to explain how the studies in this thesis were carried out including the research philosophy, methods, and design. First, via a little story, the existing ontological and epistemological stances in supply chain studies will be highlighted, and the author's consideration in the thesis will be clarified. Next, the chapter will review the methods and tools that researchers use to study large and complex systems such as production and inventory systems in supply chains. Later, the research strategy will be explained.

#### 3.1 Research philosophies

A research paradigm always has three elements: ontology, epistemology and methodology (Denzin and Lincoln, 1994). Ontology focuses on the nature of reality or knowledge. More specifically, it is about whether the reality is viewed from an objective or subjective perspective. Epistemology deals with how the world is perceived. It refers to assumptions made about the ways to gain knowledge of the reality. And methodology is influenced by both ontological and epistemological assumptions, defined as “a body of methods, procedures, concepts and rules” (Merriam-Webster Dictionary 2004). It is the rationale or basis for the selection of research methods.

A bitter story of an *Interfaces* paper on the philosophy and evolution of management science can provide some insights. In the paper, Tinker and Lowe (1984) relentlessly criticise management science for technical specialisation, lack of direction and coherence, and its elevation of “technocratic rationality” and the neglecting of “social rationality”. There are

many interesting comments from the authors; however, for our purposes, we quote what the authors simply noted that "... scientific theories are 'inventions' rather than 'discoveries'... 'Truth' is created, not discovered." These statements are well understood in many scientific fields, particularly in schools of social sciences. However, Robert Graham was amazed by the "naïveté" of Tinker and Lowe, finding their ideas "ludicrous". The prominent OR/MS figure and the president of The Institute of Management Science (Institute for Operations Research and the Management Sciences (INFORMS) is the merger of the Operations Research Society of America and The Institute of Management Sciences), Herbert Ayres, replies to Tinker and Lowe that "the whole line of thought is utter poppycock."

It is clearly that they have a major difference in the basic philosophical stance (ontology) regarding the very nature of reality. From Ayres's other comments in the review, he believes that only one single reality exists, independent of the perception of it. Whereas, Tinker and Lowe believe that as the human mind constructs the reality, there are multiple versions of reality. These two extreme philosophical assumptions concerning reality result in the difference in the ways of understanding how they obtain knowledge (epistemology), and the different research methodological approaches.

Positivists, like Ayres and Graham, assert the unity of the scientific method and the search for causal relationship. They believe the nature of supply chain research is based upon logic, mathematics and laws. Quantitative research methodology is one of its signatures. On the other end of the spectrum is interpretivism, which rejects the assumptions of positivism and advocates that human beings and their interfering and interpretation have an essential influence on social systems, as Tinker and Lowe advocated. Qualitative research methodology is usually associated with this stance. There is an alternative in the "middle" of the two basic and extreme epistemological options called 'critical realism'. It holds that it is

possible to acquire knowledge about the external world as it really is, independently of objectivity or subjectivity.

Literature shows that the dominant paradigm in operations and supply chain management studies is positivism (Meredith et al., 1989; Mentzer and Kahn, 1995; Frankel et al., 2005; Sachan and Datta, 2005; Burgess et al., 2006; Pilkington and Meredith, 2009). For example, in Burgess et al.'s (2006) research, they randomly select and systematically analyse 100 refereed journal articles in field of supply chain management, and find 97 percent of the articles applied quantitative research methods. Critical realism is also used by researchers in order to emphasise understanding over problem solving (Meredith, 2001), or for the development of supply chain theory (Rotaru et al., 2013). Although we recognise that there are various philosophical paradigms people might embrace, even in the field of management science and operational research researchers still have alternative philosophies, the choice of methodology in this thesis is originated from the objective and positivist position that the author prefers.

### **3.2 Research methods and theories**

Simulation is a method of investigating the dynamics in large and complex systems such as production and inventory systems (Forrester, 1961). Therefore it is particularly suitable for operations and supply chain management studies. Users do not need to stick to specific mathematical forms that are analytically solvable. It is also possible to include soft variables that are difficult to incorporate into mathematical models. The power of using simulation for understanding and communicating the dynamic responses in large non-linear systems has been demonstrated by Forrester (1961). Despite the fact that the work of Forrester was published nearly 60 years ago, it continuously influences the research in the field of

operations and supply chain studies. We refer readers to Edghill and Towill (1989) for a summary of Forrester's work.

However, simulation has its own drawbacks. It is somewhat cumbersome, time consuming and only limited insights are provided (Popplewell and Bonney, 1987). The exclusive use of simulation cannot provide explanatory (or analytical) insights, which was also recognised by Wikner et al. (1992). They further argue that the problem of using simulation alone is that users fail to understand how the systems structure influences dynamic behaviour.

Control theory is particularly useful for studying the structure and dynamics of a supply chain. A number of scholars have used control theory to investigate production and inventory control problems. Axsäter (1985) summarises the benefits and limitations of the approach by reviewing early works on the theory, and concludes that it is extraordinary in its ability to illustrate dynamical effects and feedback, but appears to fail to solve some production planning issues such as lot-sizing problem and sequencing.

Disney (2001) makes a good summary of the reasons for applying transfer function techniques to systems analysis, and some related to this research include:

- the standard forms simplify benchmarking (Towill, 1970);
- the block diagram technique helps identifying some important aspects of system structures easily and rapidly (Popplewell and Bonney, 1987; Nise, 2004);
- frequency domain calculations are easily obtained (Bissell, 1996);
- a single transfer function has the ability to handle several time series (Popplewell and Bonney, 1987);
- the joint use of control theory and simulation provides insights into system design.

There are two main categories of control theory: continuous time series analysis and discrete time series analysis. Regarding the former, there is a whole range of tools relating to the Laplace transform. Simon (1952) seems to be the first to apply the Laplace transform to a production and inventory system. Buck and Hill (1971) and Grubbström (1967) have found that the transforms which describe cash flows are directly related to the Net Present Value of the cash flows. Using transforms, convolution in time domain is achieved by multiplication in the frequency domain. This means, given common transfer functions, a complex system can be simply studied via simple algebraic techniques and a number of other methods developed by control engineers. However, these techniques are only applicable to linear, time invariant systems. Another limitation of the Laplace transform is that it does not handle well systems that contain pure time delays (Asl and Ulsoy, 2003). This type of system is also called a “differential delay” system. However, Warburton and Disney (2007) have used the Lambert W function to find bullwhip expressions in replenishment policies which have such property.

Discrete time is probably more applicable to replenishment policies in supply chains, because inventory levels and demands are usually not continuously monitored. Rather they are monitored periodically, and order decisions are triggered at discrete points in time. The discrete time analogue of Laplace transform is called  $z$ -transform. As with the continuous time approach the advantage of using the  $z$ -transform is that convolution in the time domain is replaced by multiplication in the frequency domain; and the drawback is that it has to be a linear, time invariant system with zero initial conditions. Nevertheless, the  $z$ -transform completely avoids the problems of pure time delay as it forms the kernel of the  $z$ -transform (Disney and Lambrecht, 2007).

Often, system dynamics simulation and control theory are used together. In some circumstances, studies of production and inventory problems can be enhanced by simulation with a basic understanding of the findings from control theory (Edghill and Towill, 1989).

Towill (1982) used simulation, techniques from control theory such as block diagram, Laplace transform, and coefficient plane models to study an Inventory and Order Based Production Control System (IOBPCS). Later, Towill (1988) presented a simulation technique that adopted control theory and supply chain behavioural knowledge called the EXSMO (EXponential SMOthing) equations. These works formulated the starting of a generic “family” of simulation models, such as the Automatic Pipeline Inventory and Order Based Production Control Systems (APIOBPCS) (John et al., 1995).

Disney and Towill (2002) developed a discrete transfer function model of a VMI supply chain. They use causal loop diagrams, block diagrams, difference equations and  $z$ -transforms to determine the dynamic stability of the system. Dejonckheere et al. (2003) used  $z$ -transform to investigate the Bullwhip Effect induced by conventional forecasting methods such as moving averages, simple exponential smoothing when used in a traditional OUT policy. After applying both continuous and discrete time approaches to study the production and inventory control system with an OUT policy, Disney et al. (2006) derived different exact results but similar managerial implications. Later, Warburton and Disney (2007) highlighted the equivalence of discrete and continuous Bullwhip Effect expressions. Other examples include: Olsmats et al. (1988), Edghill and Towill (1989), Evans et al. (1994), Berry et al. (1995), Towill et al. (1997), Tang and Naim (2001), Towill (2005), Zhou and Disney (2006), Wikner et al. (2007), Wright and Yuan (2008), Cannella and Ciancimino (2010), Lin et al. (2010), Zhou et al. (2010), Turrisi et al. (2013), Wei et al. (2013), and Hassanzadeh et al. (2014).

There are also alternative methods to study supply chains, such as management games, and dynamic programming. One of the famous management games is the Beer Game which is a simplified replica of a real world supply chain, and is often used in bullwhip related studies. It is able to provide subjective insights but it is limited in the sense that nothing can be proved from the game itself. Dynamic programming was created to solve the mathematical problems



with various multi-stage decision processes (Bellman, 1954). It has a wide range of applications in supply chains such as capacity expansion, routing (i.e. shortest paths in a network), planning, purchasing, inventory policies, and etc. Hall and Potts (2003) used dynamic programming in scheduling, batching, and delivery problems in a supply chain. Chiang (2001) applied dynamic programming into a study of regular and emergency replenishment system. Li and Ryan (2012) used dynamic programming to find the optimal inventory policy for different types of supply contracts in multi-sourcing scenarios. Dynamic programming also was adopted to design the supply chain for a new product when the design is already known (Graves and Willems, 2005). The technique helps them to determine the choice of suppliers, parts, processes, and transportation modes at each stage in the supply chain. This method is not chosen in the research because it is more applicable to optimisation problems but not efficient to learn the dynamics of a system.

### **3.3 Research strategy**

This thesis starts with a typical business environment setting, the Order-Up-To replenishment policy. A different starting point to the majority of the literature is taken with the adoption of Damped Trend forecasting techniques and no assumptions are made about demand patterns. Once the theoretical assumptions are declared, the stability of the system – in particular of Damped Trend forecasting method will be discussed, as stability is a critical criterion of a dynamic system. Then, it is important to develop a new indicator for the bullwhip effect, because the traditional measurements are not suitable for non-stationary demand patterns. In terms of benchmark models, some popular and conventional forecasting methods used in OUT policy studies will also be studied. Control theory and simulation will be used to

investigate the performance of Damped Trend forecasting with the OUT policy and the performance of benchmark models.

Then, an alternative phenomenon will be brought into the bullwhip research area, system nervousness. Theoretical assumptions such as demand process, forecasting technique, ordering and inventory policies, and scenarios with or without information sharing will be defined. We will discuss how to quantify the performance related to the nervousness, then evaluate and compare the performance of different models. As the stability conditions of this system are known, the models will be investigated without a stability analysis. Time Series Analysis and control theory are applicable at here and an analytical analysis will be considered.

### **3.4 Summary**

The nature of reality differs based on different philosophical stances of the observer. It reflects how different people perceive the world and how they learn knowledge. The debate in *Interfaces* showed that even in the field of management science and operational research, there are differences in philosophical stances. We recognise the variety of human thinking, the positive stance in this thesis is purely based upon the author's preference. The chapter also discussed the pros and cons of a number of quantitative methods that might be used in the thesis to study the dynamics of supply chain. Later, the research strategy was explained.

From next chapter, we are going to focus on the research question Q1. Starting with the presentation of the Damped Trend forecasting in frequency domain, the stability of the forecasting method will be analysed. Then a model that integrates the Damped Trend forecasts into the Order-Up-To policy will be developed and investigated.

## **4. Damped Trend Forecasting and the Order-Up-To Replenishment**

### **Policy**

The superiority of Damped Trend (DT) forecasting method has been proved in several forecasting competitions and in many other studies (Makridakis and Hibon, 2000; Fildes et al., 2008; Gardner and McKenzie, 2011), but there are only a few who have investigated its performance from supply chain perspective (Snyder et al., 2002; Acar and Gardner, 2012). In this chapter, we will investigate the supply chain dynamics produced by the Order-Up-To (OUT) policy with Damped Trend forecasts.

The OUT replenishment policy is popular in industry for minimising local inventory costs, suitable for not only level demand but also trend and / or seasonal demand. The OUT policy also works in the same discrete time as the DT forecasting method. Hence, the specific focus of this chapter is to evaluate the use of the DT forecast for the use within the linear Order-Up-To replenishment policy. Since the combined DT / OUT system is a rather large and complex system – it consists of six linear discrete time difference equations – the  $z$ -transform will be used as to model and analyse the system.

The discrete time transfer function of DT forecasting mechanism is introduced in section 4.1. Then the stability boundaries of DT forecasting are studied in section 4.2. Section 4.3 discusses the relationship between stability and invertibility for the DT forecasting method. In section 4.4, the DT forecasting methodology is incorporated into the OUT replenishment policy, and a discrete-time  $z$ -transform transfer function representation of the combined forecasting and replenishment system will be built.

### 4.1 Transfer function of Damped Trend forecasting

The  $z$ -transform is often used to solve discrete time recursive equations. It is a relatively simple task to develop a block diagram of the DT forecasting and manipulate it to obtain the  $z$ -transfer function of the system (see Figure 4.1). We refer interested readers to Nise (2004) for information on how to construct and manipulate block diagrams. In Figure 4.1, the system input is the unit impulse response,  $\varepsilon(z)$ , which is the  $z$ -transform of  $\varepsilon_t = 1$  if  $t = 1$ ,  $\varepsilon_t = 0$  otherwise.  $D(z)$  is the  $z$ -transform of the demand series  $d_t$ , which is obtained from  $D(z) = \sum_{t=0}^{\infty} (d_t) z^{-t}$ . The system output function,  $\hat{D}_k(z)$ , is the  $z$ -transform of  $k$ -step ahead forecast,  $\hat{d}_{t,t+k}$ .

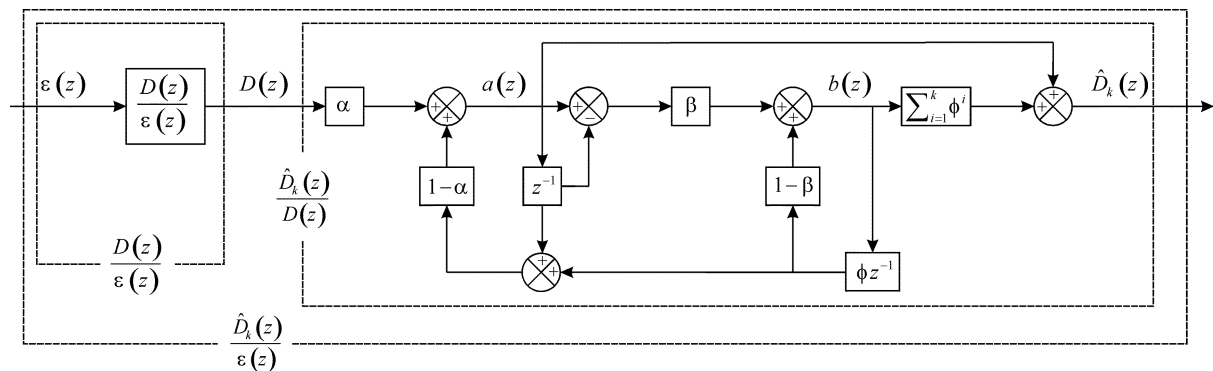

Figure 4.1 Block diagram of the Damped Trend forecasting method

The discrete time transfer function of DT forecasting is given by the transfer function of the system responding to the unit impulse response. These can be obtained from Figure 4.1 by assuming that  $D(z)/\varepsilon(z) = 1$ ,

$$\frac{\hat{D}_k(z)}{\varepsilon(z)} = \frac{a(z)}{\varepsilon(z)} + \gamma(k, \phi) \frac{b(z)}{\varepsilon(z)}, \tag{4.1}$$

where  $a(z)/\varepsilon(z)$  and  $b(z)/\varepsilon(z)$  are the transfer function of the level  $\hat{a}_t$  and the trend  $\hat{b}_t$  accordingly. These are given by

$$\frac{a(z)}{\varepsilon(z)} = \frac{z\alpha(z + \phi(\beta - 1))}{\phi(1 - \alpha) + z(\alpha - \phi - 1 + \alpha\beta\phi) + z^2}, \quad (4.2)$$

and

$$\frac{b(z)}{\varepsilon(z)} = \frac{z\alpha\beta(z - 1)}{\phi(1 - \alpha) + z(\alpha - \phi - 1 + \alpha\beta\phi) + z^2}. \quad (4.3)$$

Using (4.2) and (4.3), (4.1) can be written as

$$\frac{\hat{D}_k(z)}{\varepsilon(z)} = \frac{a(z)}{\varepsilon(z)} + \gamma(k, \phi) \frac{b(z)}{\varepsilon(z)} = \frac{z^2\alpha(1 + \beta\gamma(k, \phi)) + z\alpha(\phi(\beta - 1) - \beta\gamma(k, \phi))}{z^2 + z(\alpha - 1 - \phi + \alpha\beta\phi) + \phi(1 - \alpha)}, \quad (4.4)$$

where the equation has been expressed in standard form as coefficients of powers of the  $z$ -transform operator  $z$ . From (4.4), (4.2) and (4.3), it is easy to notice that the forecast, the level, and the trend form a second-order system, as the highest power of  $z$  in the denominator is two. This indicates that complex poles may exist in the system. From a forecasting perspective, complex poles suggest fluctuations in the forecasting errors may exist, even if there are no fluctuations in the demand series. From a control theory perspective, complex poles mean oscillations in the system output are created, even by a non-oscillatory input. The subject of the location of the poles is related to a fundamental aspect of dynamic systems, stability.

## 4.2 Stability of Damped Trend forecasts via Jury's Inners approach

There are two definitions of stability in the literature. Stability in time series literature is related to stationarity and is not our focus here. We refer to stability from a control theory perspective. Specifically, a stable system will react to a finite input and return to steady state conditions in a finite time. An unstable system will either diverge exponentially to positive or

negative infinity or oscillate with ever increasing amplitude. Oscillations in the forecasts in supply chain are costly. For example, if a forecasting system is unstable, then the future forecasts will overshoot from original demand pattern once there is an outlier in the demand series, and the forecast errors will become increasingly worse. So, as a first step to dynamically designing a supply chain replenishment rule, we must ensure that the forecasting system is stable. In this section, stability issue will be revisited and the complete stability region will be revealed.

The general form of a transfer function is  $TF(z) = \frac{B(z)}{A(z)} = \left( \sum_{i=0}^m b_i z^i \right) / \left( \sum_{i=0}^n a_i z^i \right)$  where  $n$  is the order of transfer function and for temporal causality  $m \leq n$ . The denominator of system transfer function is denoted as  $A(z)$ . To avoid confusion, here  $A(z)$  is the denominator of (4.4). Jury (1971) shows that the necessary and sufficient conditions for stability of a linear discrete system are given by  $A(1) > 0$ ,  $(-1)^n A(-1) > 0$ , and the matrices  $\mathbf{\Delta}_{n-1}^{\pm} = \mathbf{X}_{n-1} \pm \mathbf{Y}_{n-1}$  are positive innerwise. The matrices

$$\mathbf{X}_{n-1} = \begin{bmatrix} a_n & a_{n-1} & a_{n-2} & \cdots & a_2 \\ 0 & a_n & a_{n-1} & \cdots & a_3 \\ 0 & 0 & a_n & \cdots & a_4 \\ \vdots & \vdots & \vdots & \ddots & \vdots \\ 0 & 0 & 0 & \cdots & a_n \end{bmatrix}, \mathbf{Y}_{n-1} = \begin{bmatrix} 0 & 0 & 0 & \cdots & a_0 \\ \vdots & \vdots & \vdots & \ddots & \vdots \\ 0 & 0 & a_0 & \cdots & a_{n-4} \\ 0 & a_0 & a_1 & \cdots & a_{n-3} \\ a_0 & a_1 & a_2 & \cdots & a_{n-2} \end{bmatrix}, \quad (4.5)$$

are made up of co-efficients  $a_i$  of  $z$  in  $A(z)$ . Then  $A(z)$  can be expressed as

$$A(z) = \underbrace{(1-\alpha)\phi}_{a_0} + z \underbrace{(\alpha-\phi-1+\alpha\beta\phi)}_{a_1} + z^2 \underbrace{1}_{a_2}. \quad (4.6)$$

Taking each criterion in turn:

- $A(1)$  must be greater than zero:  $A(1) = A(z)|_{z \rightarrow 1}$ , that is  $A(1)$  is given by (4.6) with the  $z$  replaced with 1,

$$A(1) = \alpha(1 + \phi(\beta - 1)) > 0. \quad (4.7)$$

- $(-1)^n A(-1)$  must be greater than zero. In the same manner as above,  $(-1)^n A(-1)$  is given by (4.6) with  $z$  replaced by  $-1$  and  $n = 2$ ,

$$(-1)^n A(-1) = \alpha - 2 + \phi(\alpha - 2 + \alpha\beta) > 0. \quad (4.8)$$

- $\Delta_{n-1}^{\pm} = \mathbf{X}_{n-1} \pm \mathbf{Y}_{n-1}$  must be positive innerwise. A matrix is positive innerwise if its determinant is positive and all the determinants of its Inners are also positive. Because (4.6) is only of second order as  $n = 2$ , the matrices  $\Delta_{n-1}^{\pm}$  only contain one element. Thus, to ensure that the elements of (4.5) are positive innerwise, it is enough, in our system here, that

$$\left. \begin{aligned} \Delta_{n-1}^+ &= a_2 + a_0 = 1 + (1 - \alpha)\phi > 0 \\ \Delta_{n-1}^- &= a_2 - a_0 = 1 - (1 - \alpha)\phi > 0 \end{aligned} \right\}. \quad (4.9)$$

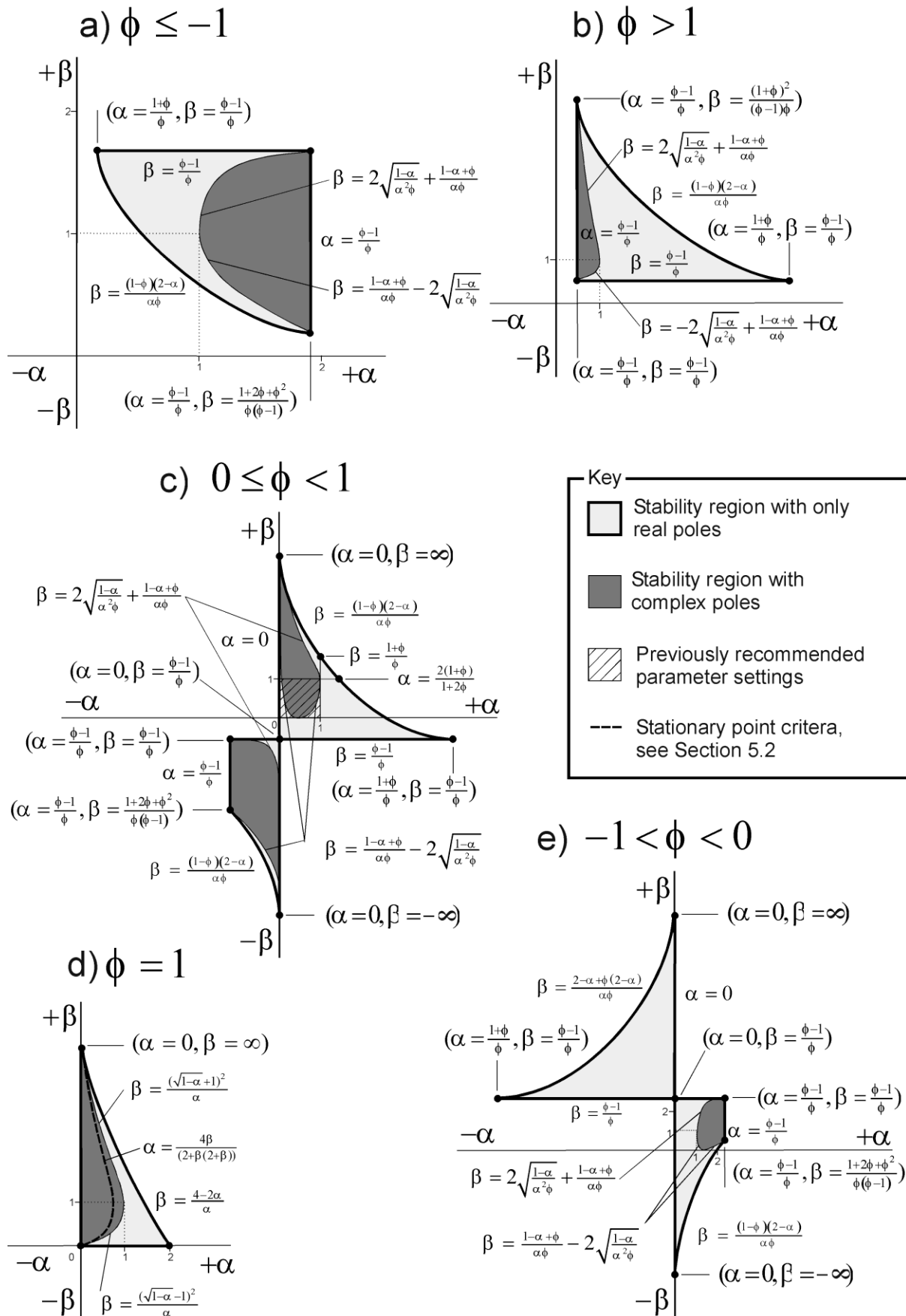

Figure 4.2 Damped Trend stability region



Figure 4.2 illustrates all possible stability boundaries and how they change for different  $\phi$ . (4.7) splits the  $\{\alpha, \beta\}$  parametric plane into quarters along the lines given by  $\alpha = 0$  and  $\beta = (\phi - 1)/\phi$ . (4.8) divides the  $\{\alpha, \beta\}$  parametric plane along the curve  $\beta = (2 - \alpha + 2\phi - \alpha\phi)/\alpha\phi$ , which has an asymptote at  $\alpha = 0$ . From (4.9), the criteria  $\Delta_{n-1}^+$  divides the parametric plane along  $\alpha = (\phi + 1)/\phi$ ,  $\Delta_{n-1}^-$  divides the plane along  $\alpha = (\phi - 1)/\phi$ . The dark grey area in Figure 4.2 indicates where the stable parameter settings induce conjugate complex poles in the forecasting system. Complex poles within the stability region mean a number of oscillations will be present in the impulse response of the system. Although Figure 4.2 is a characterisation of the parameter plane, all the boundaries of stability region and the oscillation region (stability region with complex poles) have been made explicit in Figure 4.2.

When  $\phi > 0$ , our results are the same as the stability region in Gardner and McKenzie (1985). Similar findings were observed from Figure 4.2 for Holts method and SES. When  $\phi = 1$ , we have the Holts method, and the stability conditions are  $0 < \alpha < 2$ ,  $0 < \beta < (4 - 2\alpha)/\alpha$ . Both stability region and the oscillation region are identical to McClain and Thomas (1973). When  $\beta = 0$  and  $\phi = 0$ , the SES stability boundary observed,  $0 < \alpha \leq 2$ , is consistent with Brenner et al. (1968). It is common practice in exponential smoothing models to restrict the smoothing parameters  $\{\alpha, \beta\}$  to the  $[0, 1]$  interval (Holt, 2004; Winters, 1960). The damping parameter has also been proposed to be restricted to  $0 \leq \phi \leq 1$  (Gardner, 1985, 1990; Gardner and McKenzie, 1985, 1989). However, it is interesting to note that there are stable DT forecasts for a much broader range of parameter values than those usually recommended in the literature.

### 4.3 Invertibility and Stability

The concept of invertibility in time series analysis refers to the feasibility of the identification of the demand process structure from past observations of demand. Invertibility is related to linear moving average (MA) models or the MA part of ARIMA models. If an MA model (or an MA part in ARIMA models) can be expressed as an autoregressive (AR) model of infinite order, the model is deemed invertible, and implies all relevant state variables are directly observable. By investigating the arithmetic relationship between stability and invertibility for the DT forecasting system, we found the invertibility region is the same as the stability region for DT method (and all its special cases such as SES, Holts method etc.).

All linear exponential smoothing methods have equivalent ARIMA models (Box et al. 2008).

The pure DT method is equivalent to the ARIMA(1,1,2) model, which can be written as

$$(1-B)(1-\phi B)d_t = \underbrace{(1-\theta_1 B - \theta_2 B^2)}_{\theta(B)} e_t, \quad (4.10)$$

where  $B$  is backward shift operator (similar to but not quite the same as  $z^{-1}$  in control theory),  $\theta_1 = 1 + \phi - \alpha - \alpha\beta\phi$  and  $\theta_2 = \alpha\phi - \phi$  (Roberts, 1982). For the second-order MA part, it is invertible only if the roots of the characteristic equation

$$\theta(B) = 1 - \theta_1 B - \theta_2 B^2 = 0 \quad (4.11)$$

lie *outside* the unit circle.

In fact, we can rewrite (4.6), the denominator of the DT forecasting transfer function, using  $\theta_1$  and  $\theta_2$  as  $A(z) = z^2 - \theta_1 z - \theta_2$ . The stability condition in control theory requires the roots of

$$A(z) = z^2 - \theta_1 z - \theta_2 = 0 \quad (4.12)$$

lie *inside* the unit circle.

It is easy to notice that the roots of (4.11) are the inverse of the roots of (4.12). Remember the test for stability requires the roots of (4.12) be inside the unit circle, (4.11) requires the roots to be outside the unit circle. So the results for invertible regions and stable regions should be identical. Solving for the roots of  $\theta(B) = 0$  to find the invertibility region, we obtain

$$H_{1,2} = \left( \theta_1 \pm \sqrt{\theta_1^2 + 4\theta_2} \right) / 2. \quad (4.13)$$

There are two possible pairs of values, but this is not a problem. Solving the simultaneous inequalities  $|H_i| < 1$  for  $i = 1, 2$ , both pairs give rise to identical calculations. The results are the same as our stability conditions when  $\{\alpha, \beta\} \in \mathfrak{R}$ . Jury's Inners approach can also be used to study the invertibility region, and also returns the exactly same regions as the stability regions we previously found.

Therefore, we conclude the invertibility regions are the same as the stability region for DT forecasting (and for all of its special cases such as SES, Holts method), even though the implications of the stability and the invertibility are different. After we found there are more stable parameter values than recognised in the literature, the consistency between stability regions and invertibility regions becomes important, becomes now any stable DT parameter sets produce feasible forecasts. Therefore, it is interesting to investigate the performance over the complete stability region.

### 4.4 Integrating Damped Trend forecasting into the Order-Up-To policy

Having investigated the stability properties of the DT forecasting method, we will now look at a single echelon inventory control system where this forecasting technique is used in combination with a linear version of the Order-Up-To replenishment policy. Then the transfer functions of the DT / OUT system can be derived. Figure 4.3 below illustrates the block diagram of the DT / OUT system.

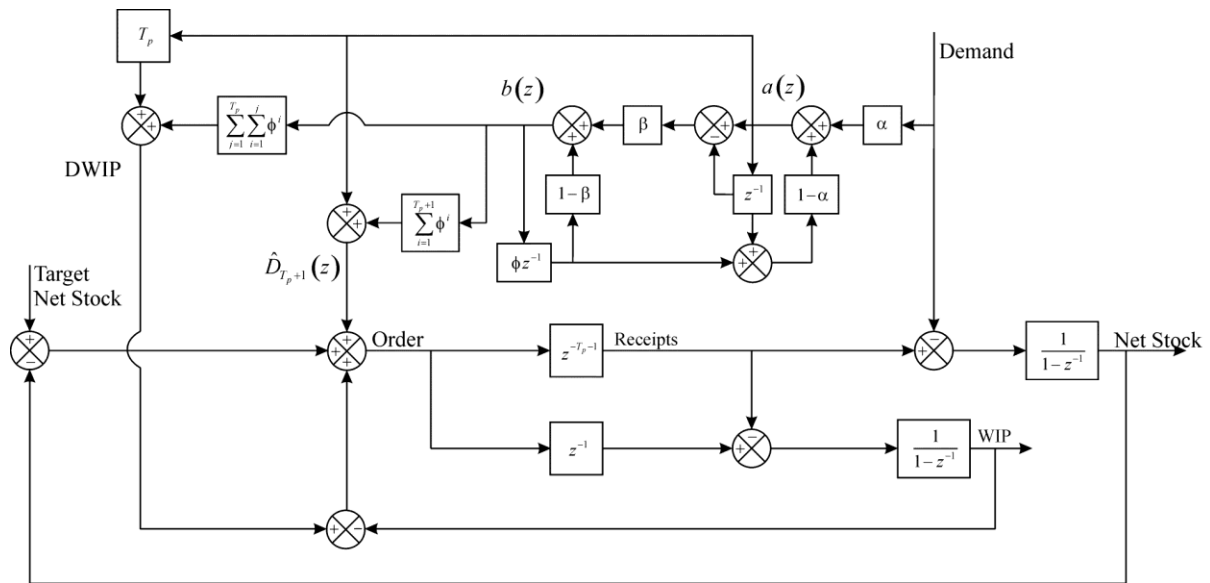

Figure 4.3 Block diagram of Damped Trend Order-Up-To system

A single retailer first receives goods in each period  $t$ . He observes and satisfies customer demand within the replenishment period,  $d_t$ . Any unfilled demand is backlogged. The retailer observes his inventory level and places a replenishment order,  $o_t$ , at the end of each period. There is a fixed time period of  $T_p \in \mathbb{N}^0$  between placing an order and receiving that order into stock. We assume that the retailer follows a simple OUT inventory policy. In an OUT policy, orders are placed to raise the inventory position,  $ip_t$ , up to an OUT level or base stock level,  $s_t$ ,

$$o_t = s_t - ip_t. \quad (4.14)$$

The inventory position is the amount of inventory on-hand + inventory on-order – backlog. The amount of inventory on-hand minus the backlog is known as the net stock level  $ns_t$ . The inventory on-order is also known as the work-in-progress  $wip_t$ . The inventory position at time period  $t$ ,  $ip_t$  is given by

$$ip_t = ns_t + wip_t. \quad (4.15)$$

The OUT level is often estimated from previous observed demand. It can be written as

$$s_t = tns + \hat{d}_{t,t+T_p+1} + \underbrace{\sum_{i=1}^{T_p} \hat{d}_{t,t+i}}_{dwip_t}, \quad (4.16)$$

where  $\hat{d}_{t,t+T_p+1}$  is the forecasted demand in period  $t+T_p+1$  made in period  $t$ . The Target Net Stock,  $tns$ , is a safety stock used to ensure a strategic level of inventory availability.  $tns$  is a time invariant constant. If under the assumptions of normally distributed forecast errors and piece-wise linear convex inventory holding ( $h$ ) and backlog costs ( $b$ ), then it is common to assume  $tns = z\sigma_{ns}$ ;  $z = \Phi^{-1}\left[\frac{b}{b+h}\right]$ . Here  $\sigma_{ns}$  is the standard deviation of the net stock levels and  $\Phi^{-1}[x]$  is the inverse of the cumulative normal distribution function evaluated at  $x$ . When  $tns = z\sigma_{ns}$ , the expected inventory costs per period is  $I_{\xi} = \sigma_{ns}(b+h)\phi[z]$ , where  $\phi[\cdot]$  is the probability density function of the normal distribution evaluated at  $z$ . The time varying desired work-in-progress,  $dwip_t = \sum_{i=1}^{T_p} \hat{d}_{t,t+i}$  is the sum of the forecasts, made at time  $t$  in the periods from  $t+1$  to  $t+T_p$ .

The order decision can be written as

$$\begin{aligned}
 o_t &= \underbrace{tns + \hat{d}_{t,t+T_p+1} + dwip_t}_{s_t} - \underbrace{(wip_t + ns_t)}_{ip_t} \\
 &= \underbrace{tns + \hat{d}_{t,t+T_p+1}}_{s_t} + \underbrace{\sum_{i=1}^{T_p} \hat{d}_{t,t+i}}_{dwip_t} - \underbrace{\sum_{i=1}^{T_p} o_{t-i}}_{wip_t} - ns_t \\
 &= s_t - s_{t-1} + d_t.
 \end{aligned} \tag{4.17}$$

Based upon (4.16) and the third expression in (4.17), the  $z$ -transform transfer function for the order rate, expressed in a manner in which the forecasting system has been left unspecified, is given by

$$\frac{O(z)}{\varepsilon(z)} = (1 - z^{-1}) \underbrace{\left( \frac{\hat{D}_{T_p+1}(z)}{\varepsilon(z)} + \frac{DWIP(z)}{\varepsilon(z)} \right)}_{z\text{-transform of } s_t} + 1. \tag{4.18}$$

As net stock level is

$$ns_t = ns_{t-1} + o_{t-T_p-1} - d_t \tag{4.19}$$

then the net stock transfer function is given by

$$\begin{aligned}
 \frac{NS(z)}{\varepsilon(z)} &= (1 - z^{-1})^{-1} \left( z^{-T_p-1} \frac{O(z)}{\varepsilon(z)} - 1 \right) \\
 &= (1 - z^{-1})^{-1} \left( z^{-T_p-1} \left( (1 - z^{-1}) \left( \frac{\hat{D}_{T_p+1}(z)}{\varepsilon(z)} + \frac{DWIP(z)}{\varepsilon(z)} \right) + 1 \right) - 1 \right).
 \end{aligned} \tag{4.20}$$

(4.18) and (4.20) are useful departure points for further analysis as the forecasting components can be simply “slotted” into  $\hat{D}_{T_p+1}(z)/\varepsilon(z)$  and  $DWIP(z)/\varepsilon(z)$  to yield system transfer functions.

We notice from (4.17) that the OUT policy requires two forecasts. One of these forecasts is a prediction, made at time  $t$  of the demand in the period  $t+T_p+1$ . Adapting the DT forecast (2.4) to achieve this is done when  $k = T_p + 1$ ,

$$\hat{d}_{t,t+T_p+1} = \hat{a}_t + \hat{b}_t \sum_{i=1}^{T_p+1} \phi^i = \hat{a}_t + \hat{b}_t \frac{\phi(\phi^{T_p+1}-1)}{\phi-1} = \hat{a}_t + \hat{b}_t \gamma(T_p, \phi). \quad (4.21)$$

The other forecast required by the OUT policy is a prediction, made at time  $t$ , of demand over the lead-time. That is the sum of demand in periods  $[t+1, t+2, \dots, t+T_p]$ . In the time domain this is

$$dwip_t = \hat{d}_{t,[t+1,t+T_p]} = \sum_{i=1}^{T_p} \hat{d}_{t,t+i} = \hat{a}_t T_p + \hat{b}_t \eta(T_p, \phi). \quad (4.22)$$

where  $\eta(T_p, \phi) = \sum_{j=1}^{T_p} \sum_{i=1}^j \phi^i = \left(\frac{\phi}{1-\phi}\right) (T_p - \gamma(T_p, \phi)) = \phi \left( T_p (1-\phi) + \phi(\phi^{T_p} - 1) \right) / (\phi-1)^2$ .

The transfer function of the DT forecast and work-in-progress target can be built up from the two auxiliary transfer functions,  $a(z)/\varepsilon(z)$  and  $b(z)/\varepsilon(z)$  previously given in (4.2) and (4.3). The  $z$ -transforms of the two DT forecasts required by the OUT policy are

$$\begin{aligned} \frac{\hat{D}_{T_p+1}(z)}{\varepsilon(z)} &= a(z) + \gamma(T_p+1, \phi) b(z) = a(z) + (\gamma(T_p, \phi) + \phi^{k+1}) b(z) \\ &= \frac{z^2 \alpha \left( 1 + \beta (\gamma(T_p, \phi) + \phi^{T_p+1}) \right) + z \alpha \left( \phi(\beta-1) - \beta (\gamma(T_p, \phi) + \phi^{T_p+1}) \right)}{z^2 + z(\alpha(\beta\phi+1) - \phi - 1) + \phi(1-\alpha)}, \end{aligned} \quad (4.23)$$

and

$$\begin{aligned}\frac{DWIP(z)}{\varepsilon(z)} &= a(z) + \eta(T_p, \phi)b(z) \\ &= \frac{z^2 \alpha (T_p + \beta \eta(T_p, \phi)) + z \alpha (T_p (\beta - 1) \phi - \beta \eta(T_p, \phi))}{z^2 + z(\alpha(\beta \phi + 1) - \phi - 1) + \phi(1 - \alpha)}.\end{aligned}\quad (4.24)$$

Then using (4.18) and (4.20) we are able to obtain the transfer function of the OUT replenishment orders,

$$\frac{O(z)}{\varepsilon(z)} = 1 + \frac{(z-1)\alpha\left((1+T_p)(z+\phi(\beta-1)) + \beta(z-1)(\gamma(1+T_p, \phi) + \eta(T_p, \phi))\right)}{z^2 + z(\alpha(\beta\phi+1) - \phi - 1) + \phi(1-\alpha)}, \quad (4.25)$$

and the transfer function of net stock level,

$$\frac{NS(z)}{\varepsilon(z)} = \frac{1 - z^{T_p+1}}{z^{T_p}(z-1)} + \frac{\alpha\left((1+T_p)(z+\phi(\beta-1)) + \beta(z-1)(\gamma(1+T_p, \phi) + \eta(T_p, \phi))\right)}{z^{T_p}(z^2 + z(\alpha(\beta\phi+1) - \phi - 1) + \phi(1-\alpha))}. \quad (4.26)$$

It can be noticed from (4.24), (4.24), and (4.25) that the denominator of the transfer functions of the DT / OUT system has the same two poles as the transfer function of the forecast system, (4.4). This implies that the same stability conditions hold for the DT / OUT system as for the Damped Trend forecasting system. The nominator of the DT / OUT transfer function is also of second degree, but the coefficients differ, which implies that the zeros of the transfer function lie in a different location to the zeros of the forecasting system.

The transfer functions of the two required forecasts when Holts, SES or Naïve forecasting is used are summarized in Table 4.1. As the trend component of the demand process is not explicitly forecasted in the SES and the Naïve forecasting models, we follow the popular procedure and set the desired work-in-progress term to the product of the lead-time and the most recent forecast (see for example Chen et al., 2000b; Lalwani et al., 2006). Once we have



the transfer functions of these two forecasts, we can substitute them into (4.18) to obtain the order transfer function.

Forecasting Method	Transfer Functions of $\hat{d}_{t,t+T_p+1}$ and $dwip_t$
Holts method	$\frac{\hat{D}_{T_p+1}(z)}{\varepsilon(z)} = \frac{z^2\alpha(1+T_p\beta + \beta) - z\alpha(1+T_p\beta)}{z^2 + z(\alpha(1+\beta) - 2) + 1 - \alpha}$ $\frac{DWIP(z)}{\varepsilon(z)} = \frac{z^2\alpha T_p(2+T_p\beta + \beta) + z\alpha T_p(\beta(1-T_p) - 2)}{2(z^2 + z(\alpha(1+\beta) - 2) + 1 - \alpha)}$
SES	$\frac{\hat{D}_{T_p+1}(z)}{\varepsilon(z)} = \frac{z\alpha}{z + \alpha - 1}; \quad \frac{DWIP(z)}{\varepsilon(z)} = \frac{z\alpha T_p}{z + \alpha - 1}$
Naïve forecasting	$\frac{\hat{D}_{T_p+1}(z)}{\varepsilon(z)} = 1; \quad \frac{DWIP(z)}{\varepsilon(z)} = T_p$

Table 4.1 Transfer functions of  $\hat{d}_{t,t+T_p+1}$  and  $dwip_t$  for the special cases of Damped Trend Order-Up-To system

### 4.5 Summary

In this chapter, the fundamental issue, stability, of the Damped Trend forecasting as well as the DT / OUT system have been discussed. There is much broader range of stable parameters than recommended in the literature. After analysing the invertibility and stability issue, it is interesting to notice that the all stable parameter sets can produce feasible forecasts. Thus it is interesting to investigate the performance of DT method in inventory control over the whole stability region. The  $z$ -transform transfer functions of the forecasts which are necessary in OUT policy have also been derived. We also have developed an expression of order rate and

net stock amplification transfer functions in the form of the transfer functions of forecasts.

This will then be useful to further research.

In the next chapter, by exploiting the frequency response plots, the impact of the DT / OUT policy on supply chains will be investigated via the bullwhip criterion and inventory variance.

## 5. Bullwhip and Net Stock Amplification of the Damped Trend Order-Up-To Policy

The previous chapter has demonstrated that there is a much broader range of stable parameter sets for the DT forecasting system than is previously suggested in the literature. As all stable DT parameter settings can provide feasible DT forecasts, in this chapter, the performance of a stable DT / OUT system will be investigated over the complete stability region. Frequency response plots and the Fourier transform will be used to conduct the analysis.

It is difficult to quantify or determine the existence of the bullwhip effect as well as net stock amplification (*NSAmp*) when there are trends in demand series. Therefore, section 5.1 starts by outlining a technique that is useful for identifying the bullwhip effect under different demand patterns. Afterwards, the bullwhip performance of the three special cases in DT method mentioned in the previous chapter will be studied via a Frequency response analysis. Section 5.3 studies the frequency response plot of DT forecasts within the OUT policy. Later, the net stock amplification of DT / OUT system is discussed in section 5.4. Finally, a summary of the theoretical findings can be found in section 5.5.

### 5.1 The Bullwhip effect and net stock amplification in the frequency domain

Let  $\Sigma_v(\omega)$  for  $-\pi < \omega < \pi$  be the power spectral density matrix, where  $\omega$  represents the angular frequency of a stochastic vector process  $v(i)$ . Then  $\Sigma_v(\omega) = \sum_{i=-\infty}^{\infty} R_v(i) z^{-i}$ , where

$z = e^{j\omega}$  and  $R_v(i_1, i_2)$  is a scalar covariance matrix of  $v$ . If this process is stationary, then the variance matrix satisfies

$$E\{v(i)v^T(i)\} = R_v(0) = \frac{1}{2\pi} \int_{-\pi}^{\pi} \Sigma_v(\omega) d\omega. \quad (5.1)$$

Let  $H(z)$  is the transfer function of a stationary input process  $x_t$  and output process  $y_t$ . The power spectral matrix of the output process satisfies

$$\Sigma_y(\omega) = H(e^{j\omega})\Sigma_x(\omega)H^T(e^{-j\omega}) \quad (5.2)$$

and

$$E\{y(i)y^T(i)\} = R_y(0) = \frac{1}{2\pi} \int_{-\pi}^{\pi} \Sigma_y(\omega) d\omega. \quad (5.3)$$

This can be simplified if the input and output are of one dimension. Let

$H_d(z) = \frac{D(z)}{\varepsilon(z)} = d_0 + d_1z^{-1} + d_2z^{-2} + d_3z^{-3} + \dots$  be the transfer function of the demand process

(a stochastic input process  $d_t$  with i.i.d. white noise  $\varepsilon_t$ ). As each  $d_t$  is arbitrary,  $H_d(z)$  could represent any demand pattern for which there is a  $z$ -transform. This demand pattern could be, for example, stationary, non-stationary, random, deterministic and operating over a finite or an infinite time horizon. Consider the noise process as an input, and the output is the demand process,

$$\Sigma_d(\omega) = H_d(e^{j\omega})H_d(e^{-j\omega}) \quad (5.4)$$

and

$$E\{d(i)d^T(i)\} = R_d(0) = \sigma_d^2 = \frac{1}{2\pi} \int_{-\pi}^{\pi} \left| \frac{D(e^{j\omega})}{\varepsilon(e^{j\omega})} \right|^2 d\omega. \quad (5.5)$$

If the white noise is considered to be an input, and the demand variance or order variance are outputs, then

$$\begin{aligned} \Sigma_o(\omega) &= H_o(e^{j\omega})H_d(e^{j\omega})H_o(e^{-j\omega})H_d(e^{-j\omega}) \\ &= H_o(e^{j\omega})H_o(e^{-j\omega})H_d(e^{j\omega})H_d(e^{-j\omega}), \end{aligned} \quad (5.6)$$

$$E\{o(i)o^T(i)\} = \sigma_o^2 = \frac{1}{2\pi} \int_{-\pi}^{\pi} \left| \frac{O(e^{j\omega})}{\varepsilon(e^{j\omega})} \right|^2 \left| \frac{D(e^{j\omega})}{\varepsilon(e^{j\omega})} \right|^2 d\omega, \quad (5.7)$$

and

$$\Sigma_{ns}(\omega) = H_{ns}(e^{j\omega})H_{ns}(e^{-j\omega})H_d(e^{j\omega})H_d(e^{-j\omega}), \quad (5.8)$$

$$E\{ns(i)ns^T(i)\} = \sigma_{ns}^2 = \frac{1}{2\pi} \int_{-\pi}^{\pi} \left| \frac{NS(e^{j\omega})}{\varepsilon(e^{j\omega})} \right|^2 \left| \frac{D(e^{j\omega})}{\varepsilon(e^{j\omega})} \right|^2 d\omega. \quad (5.9)$$

If the demand process is independently and identically distributed (i.i.d.),  $H_d(z) = \frac{D(e^{j\omega})}{\varepsilon(e^{j\omega})} = 1$ , then the variance of orders equals to the bullwhip ratio, and the variance of net stock equals to the net stock amplification ratio. The order variance and the net stock variance can be calculated through (4.25) and (4.26) respectively.

By taking the sum of the squared impulse responses,

$$\frac{\sigma_o^2}{\sigma_d^2} = \frac{\left( \begin{aligned} &2(\phi-1)^5(1+\phi) - 2\alpha^3\phi(1+\phi+\beta\phi)(T_p(\phi-1)(1+(\beta-1)\phi) - \beta\phi^2(\phi^{T_p}-1)) \\ &(T_p(\phi-1)(1+(\beta-1)\phi) - 1 - \phi(\beta+\phi-2\beta\phi+\beta\phi^{2+T_p}-2)) + \alpha(\phi-1)^3(3- \\ &4T_p(1+(\beta-1)\phi)(\phi^2-1) + \phi((\phi-3)\phi-1 + \beta(\phi(\phi(4\phi^{T_p}(1+\phi)-9) - \\ &2)+3))) + \alpha^2(\phi-1)(2T_p^2(\phi-1)^2(1+\phi)(1+(\beta-1)\phi)^2 - 2T_p(\phi-1)(1+ \\ &(\beta-1)\phi)(1+2\beta\phi^{3+T_p}(1+\phi) - \phi(\phi+\phi^2+\beta(5\phi^2-1)-1)) + \\ &\phi(3+\phi(2\beta^2\phi(1+\phi(-4+5\phi+2\phi^{2+2T_p}-\phi^{T_p}(1+\phi)(3\phi-1)))) - 3(\phi-2)\phi^2 - \\ &6 + \beta(5+\phi(\phi(7+3\phi) - 2(\phi-1)\phi^{T_p}(1+\phi)^2 - 15)))) \end{aligned} \right)}{(\phi-1)^4(1+(\alpha-1)\phi)(\alpha-2+(\alpha+\alpha\beta-2)\phi)} \quad (5.10)$$

and

$$\frac{\sigma_{ns}^2}{\sigma_d^2} = 1 + T_p - \frac{\left( \begin{aligned} &\alpha(1-T_p^2(\phi-1)^2(1+(\beta-1)\phi)(\phi(1-\alpha+\phi-2\alpha\beta\phi+(\alpha-1)\phi^2)-1) + \\ &\phi(5\phi-4+\beta(\phi-1)^4(1+\phi)-\phi^3(5+(\phi-4)\phi) + \\ &\alpha(1+\phi(\phi(2+(\phi-2)(\phi-1)\phi)+2\beta^2\phi^2(\phi^{T_p}-1)(1-2\phi+\phi^{2+T_p}))-3+ \\ &\beta(\phi-1)^2(1+\phi(2\phi^{T_p}(1+\phi)-\phi-4)))) - 2T_p(\phi-1)(1+(\beta-1)\phi)(1+ \\ &\phi(\alpha(1+\phi((\phi-1)\phi-1+\beta(1+\phi(\phi^{T_p}(\phi+1)-3)))) - 2 - (\phi-2)\phi^2) \end{aligned} \right)}{(\phi-1)^4(1+(\alpha-1)\phi)(\alpha-2+(\alpha+\alpha\beta-2)\phi)} \quad (5.11)$$

Meanwhile, (5.10) and (5.11) can also be derived via Jury's Inners approach (Disney, 2008).

By coding Jury's Inners approach in Mathematica® Wolfram Research, appendix in Chapter

10 provides an alternative approach to find the variance function. Although from (5.10) it is

difficult to observe any intuitive results straightaway, (5.11) provides an interesting

suggestion that it might be possible to achieve  $\sigma_{ns}^2 \leq (1+T_p)\sigma_d^2$ . This is a new finding

considering that the OUT policy with other forecasting methods always require that

$\sigma_{ns}^2 > (1+T_p)\sigma_d^2$  (Disney and Towill, 2003).

For a general case, based on the expressions of  $\sigma_o^2$  and  $\sigma_d^2$  from (5.7) and (5.5), the bullwhip

exists when

$$\frac{1}{2\pi} \int_{-\pi}^{\pi} \left| \frac{O(e^{j\omega})}{\varepsilon(e^{j\omega})} \right|^2 \left| \frac{D(e^{j\omega})}{\varepsilon(e^{j\omega})} \right|^2 d\omega > \frac{1}{2\pi} \int_{-\pi}^{\pi} \left| \frac{D(e^{j\omega})}{\varepsilon(e^{j\omega})} \right|^2 d\omega. \quad (5.12)$$

If  $\left| \frac{O(e^{j\omega})}{\varepsilon(e^{j\omega})} \right| > 1 \forall \omega$  then a bullwhip effect always exists regardless of  $\left| \frac{D(e^{j\omega})}{\varepsilon(e^{j\omega})} \right| \forall \omega$ . This is a sufficient condition for bullwhip. Notice that, in order to cope with non-stationary demand processes we did not calculate the variance direct, but we have used the modulus of the order rate transfer function as an indicator to distinguish bullwhip behaviour.

In order to simplify notation we will let the modulus of the order rate transfer function be denoted by Amplitude Ratio ( $AR$ ),  $\left| \frac{O(e^{j\omega})}{\varepsilon(e^{j\omega})} \right| = AR$ . Amplitude Ratio represents the amplification of the individual harmonics with a frequency of  $\omega$  radians per period (Nise 2004). If the  $AR < 1$  holds only for a certain range of harmonic frequencies, it is still possible (but not certain) that  $\sigma_o^2 < \sigma_d^2$  – it depends on the frequency characteristics of the demand pattern. By investigating the Amplitude Ratio frequency response plots, it is able to gain insights into how the forecasting and replenishment system creates or avoids bullwhip for arbitrary demand patterns.

The frequency response (the Amplitude Ratio over  $\omega$ ) of a discrete time system is a function with a periodicity of  $2\pi$ . However, we only need to study the  $AR$  for frequencies in the period  $[0, \pi]$ , as the frequency response plot on  $[-\pi, 0]$  is a simple reflection of  $[0, \pi]$  about the ordinate. Furthermore we note that  $AR|_{\omega=0} = 1$  and  $\frac{dAR}{d\omega}|_{\omega=0} = 0$  for our DT / OUT system.  $AR|_{\omega=0} = 1$  because the transfer function  $O(z)/\varepsilon(z)$  has equal power of  $z$  in both the nominator and denominator and it is a passive system with a unity gain. Let us now take a look at the frequency response for the three special cases of the DT / OUT system.

### 5.2 Frequency response of three special cases of the Damped Trend Order-Up-To policy (with Naïve, SES, or Holts forecasts)

When Naïve forecasts ( $\phi = \beta = 0, \alpha = 1$ ) are used in the OUT policy with unspecified lead-time, the AR is

$$AR = \sqrt{1 + 2(1 + T_p)(2 + T_p)(1 - \cos(\omega))}, \tag{5.13}$$

which is strictly increasing in  $\omega$  within the interval  $(0, \pi)$ , as

$$\frac{dAR}{d\omega} = \frac{(1 + T_p)(2 + T_p)\sin(\omega)}{\sqrt{1 + 2(1 + T_p)(2 + T_p)(1 - \cos(\omega))}} > 0, \tag{5.14}$$

$AR|_{\omega=0} = 1$  and  $AR|_{\omega=\pi} = 3 + 2T_p$ , see Figure 5.1a. This means  $AR \geq 1$  for all frequencies. This implies that the OUT policy with Naïve forecasts will produce bullwhip for every possible demand pattern and for all lead-times.

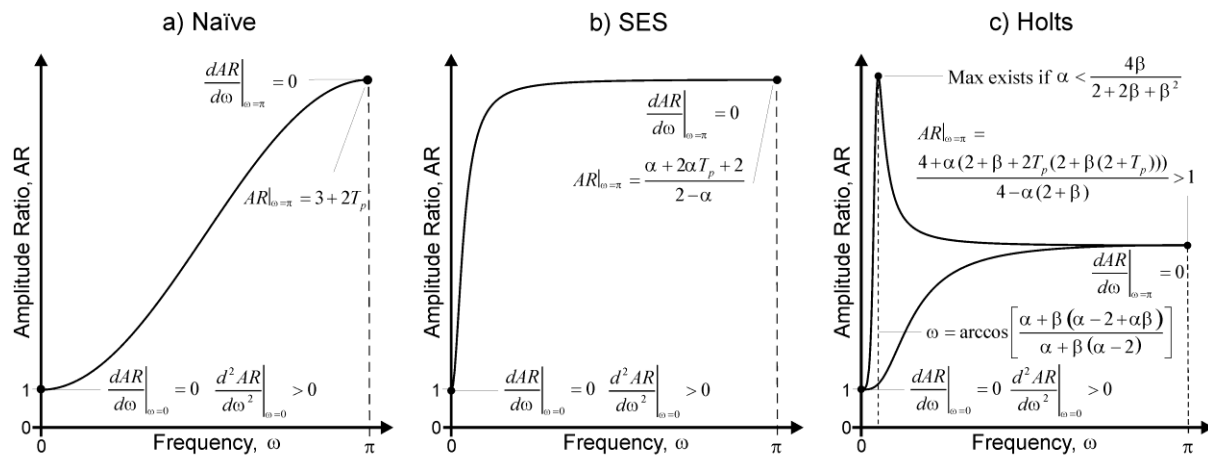

Figure 5.1 Frequency response of the OUT policy with Naïve, SES and Holts forecasts

Figure 5.1b shows when stable SES forecasting ( $\phi = \beta = 0, 0 < \alpha < 2$ ) is used in the OUT policy. The AR is given by



$$AR = \sqrt{\frac{2 + \alpha(2 + \alpha + 2T_p(2 + \alpha + T_p\alpha)) - 2(1 + T_p\alpha)(1 + \alpha(1 + T_p))\cos(\omega)}{2 + \alpha(\alpha - 2) + 2(\alpha - 1)\cos(\omega)}}, \quad (5.15)$$

which is also a strictly increasing function within the frequency interval  $(0, \pi)$  as the first order derivative

$$\frac{dAR}{d\omega} = \frac{(1 + T_p)\alpha^3(2 + T_p\alpha)\sin(\omega)}{\sqrt{(2 + \alpha(\alpha - 2) + 2(\alpha - 1)\cos(\omega))^3 \left( 2 + \alpha(2 + \alpha + 2T_p(2 + \alpha(1 + T_p))) - 2(1 + T_p\alpha)(1 + \alpha(1 + T_p))\cos(\omega) \right)}} \quad (5.16)$$

is greater than zero when  $T_p \geq 0$ ,  $0 \leq \alpha \leq 2$ , and  $0 < \omega < \pi$ . Together with  $AR|_{\omega=0} = 1$ , it is straightforward that  $AR \geq 1 \forall \omega$ . In other words, the OUT policy with SES forecasting will always generate bullwhip effect for all demand patterns and for all lead-times. This finding is consistent with the results in Desjonckheere et al. (2003), but their conjecture was not formally proved.

When a stable Holts forecasting mechanism ( $\phi = 1$ ,  $0 < \alpha < 2$ ,  $0 < \beta < (4 - 2\alpha)/\alpha$ ) is used, the  $AR$  is given by

$$AR = \sqrt{\frac{\left( \frac{2 + \alpha(1 + 2T_p) + \alpha\beta T_p(2 + T_p) - \left( (2 + \alpha(1 + 2T_p) + \alpha\beta(1 + T_p))^2 \cos(\omega) \right)}{\alpha(1 + \beta) - 2 - (\alpha - 2)\cos(\omega)} + \alpha^2(1 + \beta(1 + T_p))^2 \sin(\omega)^2 \right)^2}{(\alpha(1 + \beta) - 2 - (\alpha - 2)\cos(\omega))^2 + \alpha^2 \sin(\omega)^2}}. \quad (5.17)$$

The frequency response originates at  $AR|_{\omega=0} = 1$  and ends at

$$AR|_{\omega=\pi} = \frac{4 + \alpha(2 + \beta + 2T_p(2 + \beta(2 + T_p)))}{4 - \alpha(2 + \beta)} > 1, \quad (5.18)$$

see Figure 5.1c. By investigating the derivative

$$\frac{dAR}{d\omega} = \frac{\left( 4(1+T_p)\alpha^2(2+\beta(1+T_p))(4+T_p\alpha(T_p\beta+2(1+\beta))) \right)}{\left( (\alpha(1+\beta(1+\beta))-2\beta-(\alpha(1+\beta)-2\beta)\cos(\omega))\cos(\frac{\omega}{2})\sin(\frac{\omega}{2})^3 \right)}, \quad (5.19)$$

$$\sqrt{\left( (\alpha(1+\beta)-2-(\alpha-2)\cos(\omega))^2 + \alpha^2\sin(\omega)^2 \right)^3}$$

$$\sqrt{\left( \left( 2+\alpha((1+2T_p)+T_p\beta(2+T_p)) - \left( 2+\alpha((1+2T_p)+\beta(1+T_p)^2) \right) \cos(\omega) \right)^2 + \alpha^2(1+\beta(1+T_p))^2\sin(\omega)^2 \right)}$$

we find that in between  $\omega=0$  and  $\omega=\pi$ , there are two different AR responses. Either the AR is strictly increasing in  $\omega$  or, when  $\alpha < 4\beta/(2+\beta(2+\beta))$ , there is a stationary point within the  $\omega \in (0, \pi)$  interval, see Figure 4.2d. The criteria for the stationary point,  $\alpha < 4\beta/(2+\beta(2+\beta))$ , was found by setting  $dAR/d\omega=0$  and solving for  $\alpha$ . Interesting there is no influence of lead-time  $T_p$  on this boundary. When there is a stationary point, the AR is an increasing function in  $\omega$  until  $\omega = \arccos((\alpha + \beta(\alpha(1+\beta) - 2))/(\alpha(1+\beta) - 2\beta))$  at which point it becomes a decreasing function until  $\omega = \pi$ . The stationary point, if it exists, will be maximum. Therefore, as  $AR \geq 1 \forall \omega$ , the bullwhip is created by this system for any lead-time, any demand pattern.

Using those facts we are able to prove that three special cases of DT / OUT system – the Order-Up-To with Naïve, SES and Holts forecasts – will, for any demand patterns and all lead-times, always generate bullwhip.

### 5.3 Frequency response of the OUT policy with Damped Trend forecasts

The DT / OUT frequency response is more complex than the previous cases (see (5.20)). The conditions for which the  $AR$  curve is greater than one cannot be determined analytically. Because of this, the investigation is divided into three steps / parts. First, we analyse the low-frequency response ( $\omega$  near 0). Second, we look at the high frequency response ( $\omega$  at  $\pi$ ). Third, we determine the number of stationary points within the interval  $(0, \pi)$  in order to gain information on the minima and maxima and by this obtain insights on the fluctuating behaviour of the frequency response. In this section, many of the required equations (that have been obtained via Mathematica ® Wolfram Research) have been omitted as they are lengthy, complex and difficult to analyse.

$$AR^2 = \frac{\left( \begin{array}{l} e^{2i\omega} \left( (\phi-1)^2 + \alpha(1-T_p)(\phi-1)(1+\phi(\beta-1)) + \phi(\beta+\phi-2-2\beta\phi + \beta\phi^{2+T_p}) \right) + \\ \phi \left( 1-T_p\alpha(\phi-1)(1+\phi(\beta-1)) + \phi \left( \phi(1+\alpha\beta(\phi^{T_p}-1)) - 2 \right) \right) + \\ e^{i\omega} \left( \phi+T_p\alpha(1+\phi(\beta-1))(\phi^2-1) - 1 - \phi \left( \phi(\phi-1) + \alpha \left( 1 + \phi \left( \phi(1+2\beta(\phi^{T_p}-1)) - 2 \right) \right) \right) \right) \end{array} \right)}{(\phi-1)^4 \left( e^{2i\omega} + \phi - \alpha\phi + e^{i\omega}(\alpha - \phi + \alpha\beta\phi - 1) \right) \left( 1 - e^{2i\omega}\phi(\alpha-1) - e^{i\omega}(1+\phi - \alpha(1+\beta\phi)) \right)}$$

(5.20)

We know that  $AR|_{\omega=0} = 1$  and  $\frac{dAR}{d\omega}|_{\omega=0} = 0$ . The sign of the second derivative of the  $AR$  function at  $\omega = 0$  indicates a local increasing or decreasing behaviour in the  $AR$  function near zero. This is an indicator of whether a bullwhip effect is produced when demand is dominated by low frequency harmonics. Because of this, the geometrical implications of  $\frac{d^2AR}{d\omega^2}|_{\omega=0}$

determines whether the  $AR$  value when  $\omega$  is near 0 (denoted as  $AR|_{\omega \rightarrow 0}$ ) can be greater or smaller than one. We also investigate high frequency response from the value of  $AR$  at  $\omega = \pi$ . Finally, the shape of the  $AR$  curve is determined by combining information on the number of stationary points within the  $\omega \in (0, \pi)$  interval with information obtained from the first two steps. We can then characterise the  $AR$  plot for the DT / OUT system and gain insights into this bullwhip behaviour.

First, consider low-frequency behaviour. Although  $AR|_{\omega=0} = 1$  and  $\frac{dAR}{d\omega}|_{\omega=0} = 0$ , the second derivative can be positive, zero or negative. The sign of the second derivative has geometrical implications. If  $\frac{d^2AR}{d\omega^2}|_{\omega=0} > 0$  the graph of  $AR$  will be *convex* in a small interval  $[0, \delta)$  with a local minimum at  $\omega = 0$ , which means  $AR|_{0 < \omega < \delta} > 1$ . If  $\frac{d^2AR}{d\omega^2}|_{\omega=0} < 0$ , the  $AR$  curve will be *concave* in a small interval  $[0, \delta)$  and the point at  $\omega = 0$  is a local maximum, which means  $AR|_{0 < \omega < \delta} < 1$ . A *convex*  $AR$  indicates that the DT / OUT system will generate bullwhip when demands are dominated by the low frequency harmonics in  $[0, \delta)$ . A *concave*  $AR$  implies that the DT / OUT policy is able to avoid generating bullwhip for demands that are dominated by low frequency harmonics in  $[0, \delta)$ . If the second derivative is zero, theoretically, the origin could be an inflection point if the lowest-order non-zero derivative is of an odd order since the first derivative is already zero. However, for all the possible DT settings, we found the lowest-order non-zero derivative is always of even order. Then, concurring with fundamental knowledge of the periodicity of the frequency response, the stationary point at  $\omega = 0$  has to be either a local maximum or a local minimum, when the second derivative is zero.

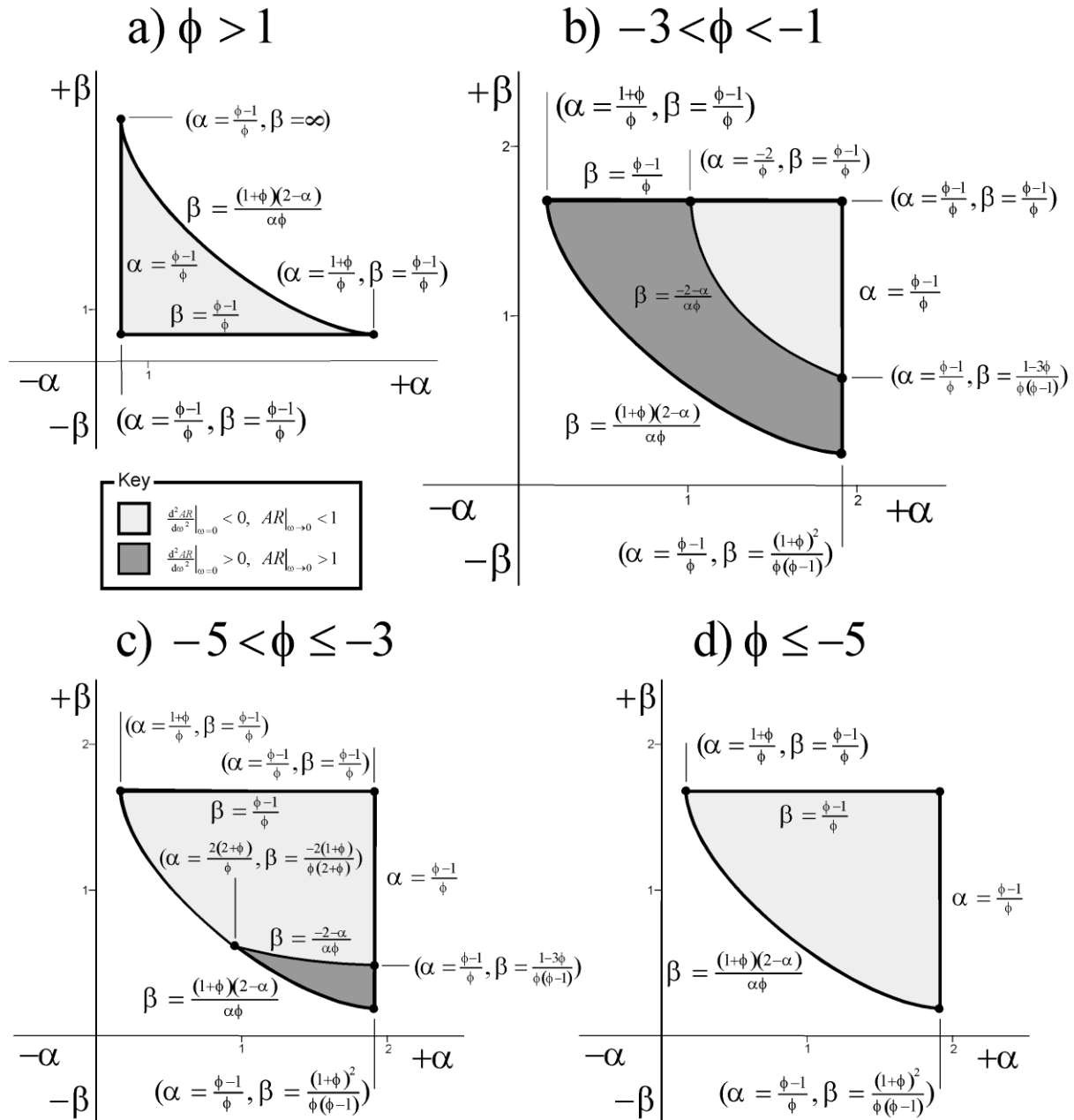

Figure 5.2 Possible settings that result in  $AR < 1$  near  $\omega = 0$  when  $T_p = 1$

When the lead-time  $T_p = 1$  and  $\phi \in [-1, 0) \cup (0, 1)$  (that is, if  $-1 \leq \phi < 0$  or  $0 < \phi < 1$ , see Figure 4.2c or Figure 4.2e), then  $\frac{d^2 AR}{d\omega^2} \Big|_{\omega=0} > 0$ . This means that these settings will always amplify low frequency harmonics. When  $\phi > 1$  or  $\phi \leq -5$  (Figure 5.2a and Figure 5.2d) the AR near  $\omega = 0$  is always concave, implying low frequency harmonics are attenuated. However when  $\phi < -1$ , the second derivative can be positive, negative or zero. Figure 5.2

maps out the areas of the parametric plane where bullwhip is avoided for demand patterns that are dominated by low frequency harmonics. The curves which separate out the two classes of bullwhip behaviour for when  $-3 < \phi < -1$  are  $\alpha = \frac{\phi-1}{\phi}$  and  $\beta = \left\{ \frac{-2-\alpha}{\alpha\phi}, \frac{\phi-1}{\phi} \right\}$ . When  $-5 < \phi \leq -3$  the curves  $\alpha = \frac{\phi-1}{\phi}$  and  $\beta = \frac{(1+\phi)(2-\alpha)}{\alpha\phi}$  separate the different classes bullwhip behaviour. These curves were all obtained by setting  $\left. \frac{d^2 AR}{d\omega^2} \right|_{\omega=0} = 0$  and solving for the relevant variables.

Second, consider the high-frequency bullwhip behaviour near  $\omega = \pi$  when  $T_p = 1$ ,

$$AR|_{\omega=\pi} = \frac{\left( 2(1+\phi) + \alpha(3 + \phi(3 + \beta(3 + 4\phi))) \right)^2}{(\alpha - 2 + \phi(\alpha + \alpha\beta - 2))^2}. \quad (5.21)$$

DT forecasts with  $\phi > 1$  or  $\phi \leq -3$  always generate bullwhip for high-frequency demands as  $AR|_{\omega=\pi} > 1$ . If  $\phi = -1$ , then  $AR|_{\omega=\pi} = 1$ . Interesting, here are some circumstances that  $AR|_{\omega=\pi} < 1$ , see Figure 5.3.  $AR|_{\omega=\pi} < 1$  indicates that the DT enabled OUT policy is able to avoid inducing bullwhip when demand is dominated by high frequency harmonics. This bullwhip avoidance occurs for  $0 < \phi < 1$  when  $(\phi-1)\phi^{-1} < \alpha < 0$  and  $(\phi-1)\phi^{-1} < \beta < -\phi^{-1}$ ;  $-1 < \phi < 0$  when  $0 < \alpha < (\phi-1)\phi^{-1}$  and  $-\phi^{-1} < \beta < (\phi-1)\phi^{-1}$ ; and for  $-3 < \phi < -1$  when  $\alpha < (\phi-1)\phi^{-1}$  and  $\frac{-(2+\alpha)(1+\phi)}{\alpha\phi(1+2\phi)} < \beta < -\phi^{-1}$ .

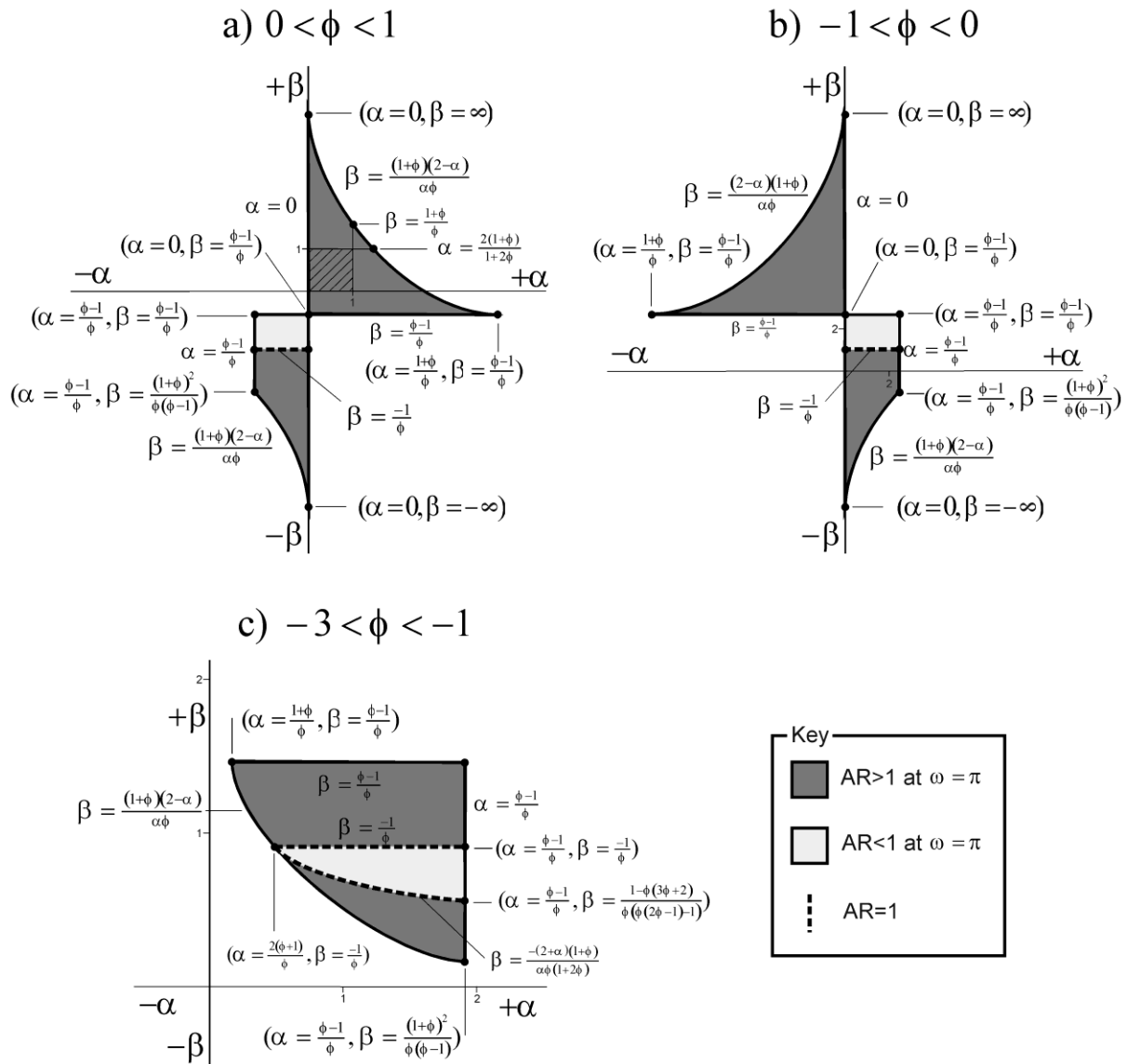

Figure 5.3 Possible settings that result in  $AR \leq 1$  near  $\omega = \pi$  when  $T_p = 1$

Third, we investigate the number of stationary points within the interval  $\omega \in (0, \pi)$  to determine the shape of the AR curve. It is regrettable that the solution to  $\frac{dAR}{d\omega} = 0$  is too lengthy and too complex to be presented. However, we found the equation can be written as

$$\frac{2\alpha \sin[\omega] (g_1(\alpha, \beta, \phi) \cos[2\omega] + g_2(\alpha, \beta, \phi) \cos[\omega] + g_3(\alpha, \beta, \phi))}{(\phi - 1)^4 \left( (f_1(\alpha, \beta, \phi) + f_2(\alpha, \phi) \cos[\omega])^2 + (f_3(\alpha, \phi) \sin[\omega])^2 \right)} = 0. \quad (5.22)$$

$f_1(\alpha, \beta, \phi)$ ,  $g_1(\alpha, \beta, \phi)$ ,  $g_2(\alpha, \beta, \phi)$ , and  $g_3(\alpha, \beta, \phi)$  are different functions containing the variables  $\{\alpha, \beta, \phi\}$ .  $f_2(\alpha, \phi)$  and  $f_3(\alpha, \phi)$  are functions that contain the variables  $\{\alpha, \phi\}$ . It is easy to notice that the denominator is always positive. In the numerator,  $\alpha = 0$  is on the stability boundary, which is not a desirable solution.  $\sin[\omega]$  is always positive when  $\omega \in (0, \pi)$ . Then (5.22) can be further simplified to

$$g_1(\alpha, \beta, \phi)\cos[2\omega] + g_2(\alpha, \beta, \phi)\cos[\omega] + g_3(\alpha, \beta, \phi) = 0. \quad (5.23)$$

There are nine different possible solutions under this circumstance, as shown in Table 5.1, where  $\Delta = 8(g_1(\alpha, \beta, \phi))^2 + (g_2(\alpha, \beta, \phi))^2 - 8g_1(\alpha, \beta, \phi)g_3(\alpha, \beta, \phi)$ . The outers of the table are conditions on  $g_1(\alpha, \beta, \phi)$ ,  $g_2(\alpha, \beta, \phi)$ ,  $g_3(\alpha, \beta, \phi)$  or  $\Delta$ . The inners of the table illustrate the number and the location of the stationary point (if exists) under these conditions. In this table, “no real solution” indicates that a stationary point does not exist. Additionally, if the corresponding conditions cannot hold simultaneously, there is also no stationary point.

For example, if within the stability regions,  $g_1(\alpha, \beta, \phi) = 0$ ,  $g_2(\alpha, \beta, \phi) \neq 0$  and  $g_3(\alpha, \beta, \phi) = 0$  are all satisfied, then there is one stationary point at  $\omega = \frac{\pi}{2}$ ; if these conditions do not hold simultaneously within the stability regions, then there is no stationary point. Combining these conditions and the stability conditions, inequalities are setup and solved. Figure 5.4 illustrates how many possible stationary points there are for different stable parameter settings when  $T_p = 1$ . The numbers  $\{0, 1, 2\}$  in Figure 5.4 denote the possible number of stationary points in each region. The fact that there are only a maximum of two stationary points in the frequency domain should come as no surprise as we are dealing with a second order system (a system with two poles and two zeros).



Conditions		$g_2(\alpha, \beta, \phi) \neq 0$	
		$\Delta < 0$	$\Delta > 0$
$g_1(\alpha, \beta, \phi) = 0$	$g_3(\alpha, \beta, \phi) = 0$	$g_2(\alpha, \beta, \phi) = 0$	$\omega = \frac{\pi}{2}$
	$g_3(\alpha, \beta, \phi) \neq 0$	no real solution	$\omega = \arccos \left[ \frac{g_3(\alpha, \beta, \phi)}{g_2(\alpha, \beta, \phi)} \right]$
$g_1(\alpha, \beta, \phi) \neq 0$	$g_3(\alpha, \beta, \phi) = 0$	$\omega = \frac{\pi}{4}$	$\omega = \arccos \left[ \frac{g_2(\alpha, \beta, \phi)}{4g_1(\alpha, \beta, \phi)} \right]$
	$g_3(\alpha, \beta, \phi) \neq 0$	$\omega = \frac{1}{2} \arccos \left[ \frac{g_3(\alpha, \beta, \phi)}{g_1(\alpha, \beta, \phi)} \right]$	$\omega = \arccos \left[ \frac{-g_2(\alpha, \beta, \phi) \pm \sqrt{\Delta}}{4g_1(\alpha, \beta, \phi)} \right]$

Table 5.1 Conditions and possible solutions for Equation (5.23)

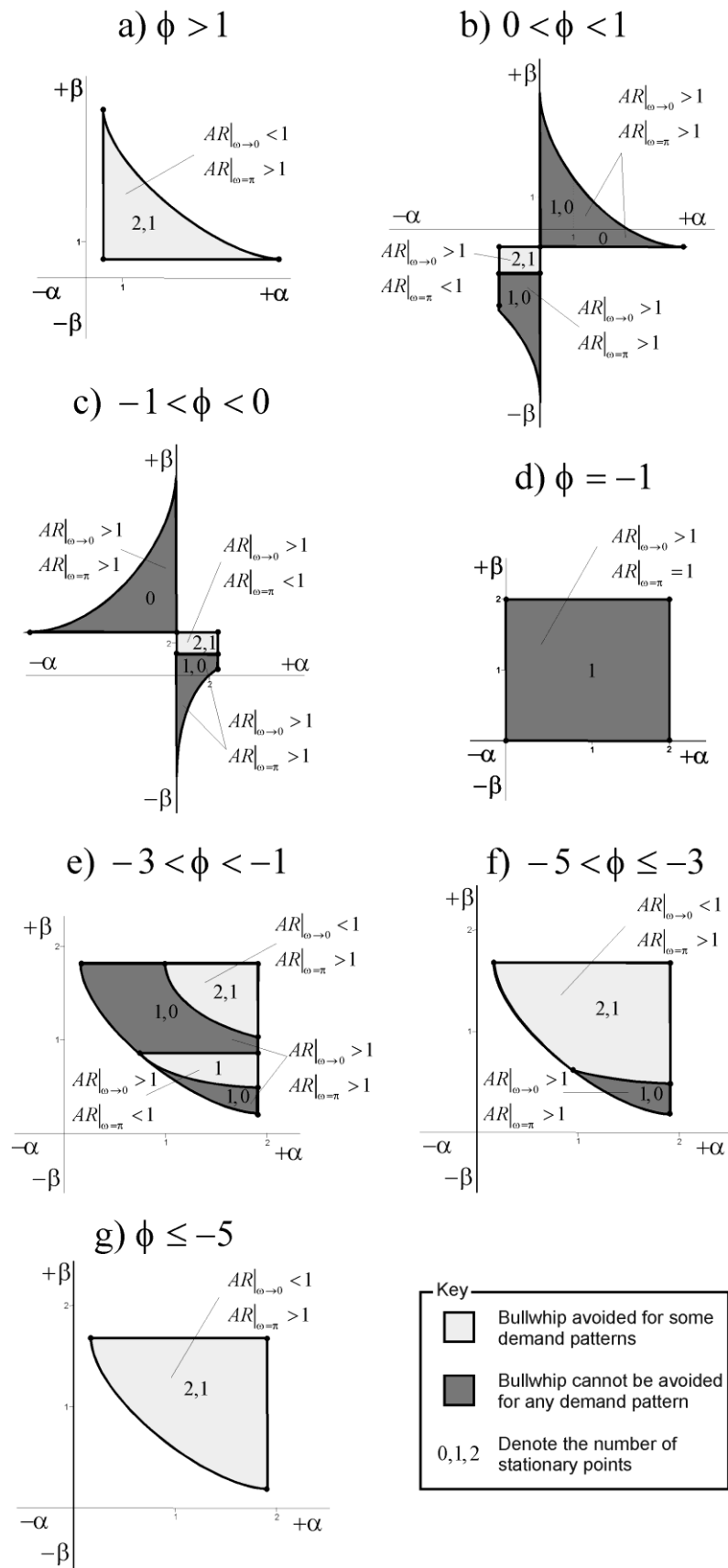

Figure 5.4 Number of stationary points within  $\omega \in (0, \pi)$  and value of AR near  $\omega = 0$  and  $\omega = \pi$  when  $T_p = 1$

With this information, as well as the information about the frequency responses at low- and high-frequencies, we can characterise the shape of the  $AR$  curve. It is easy to verify from our discussion of Figure 5.2 and Figure 5.3 that  $AR|_{\omega \rightarrow 0} < 1$  and  $AR|_{\omega = \pi} < 1$  cannot exist together (see Figure 5.4e for an alternative verification). This concurs with the fact that the system has two poles and two zeros (i.e. the amplitude has at most two stationary points, a minimum and maximum) which prohibits the existence of a system with  $AR|_{\omega \rightarrow 0} < 1$  and  $AR|_{\omega = \pi} < 1$ . It implies that the DT / OUT system cannot avoid amplifying individual harmonics for the whole range of the frequency spectrum, though there may or may not be a bullwhip effect.

When  $0 \leq \phi \leq 1$ ,  $\alpha > 0$  and  $\beta > 0$  (the traditionally advised parameter setting by Gardner and McKenzie (1985)) then  $AR|_{\omega \rightarrow 0} > 1$ ,  $AR|_{\omega = \pi} > 1$ , and there is either one stationary point or no stationary points within  $\omega \in (0, \pi)$ . It is then not difficult to visualise the  $AR$  curve and realise that  $AR > 1$  for all frequencies  $\omega$  (using the same line of reasoning that we used for the Holts method). This means the traditional DT settings will always result in an OUT policy that produces a bullwhip effect for any demand pattern. Given the relevance in the literature to these parameter settings, this is an important new insight. The same bullwhip behaviour happens at the parameter settings within the dark grey areas of Figure 5.4. Nevertheless, some of these settings may still provide relatively good performance, see for example b) and e) in Figure 5.5.

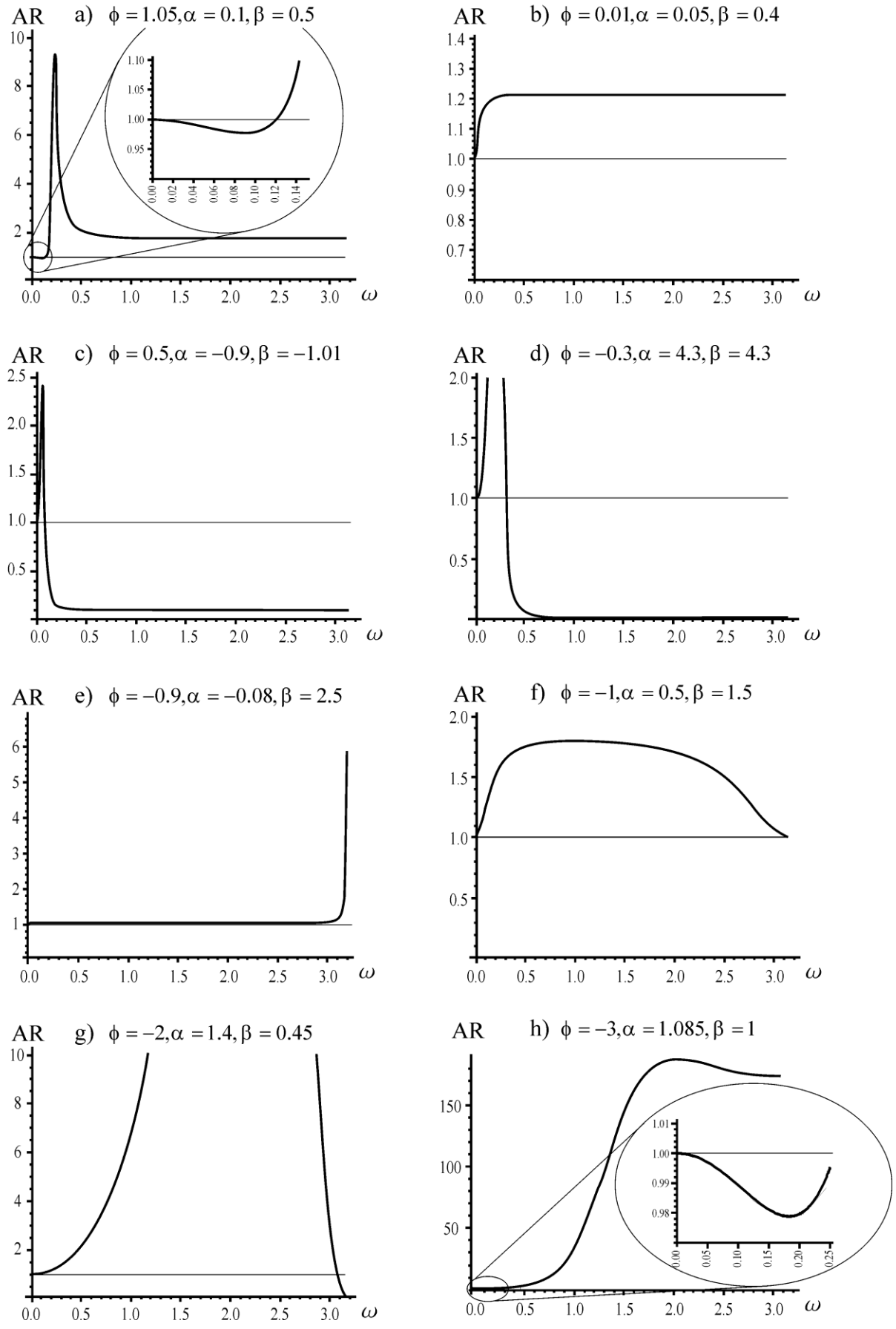

Figure 5.5 Some examples of the AR plot when  $T_p = 1$

For non-traditional parameter settings, however, it is interesting that for some demand patterns the bullwhip effect can be avoided. Some evidences are given in Figure 5.5 where all possible behaviours of the frequency response have been characterised. The parameter settings of frequency response plot a) and h) in Figure 5.5 are from the bullwhip avoidance areas in Figure 5.4a and Figure 5.4f. It is not difficult to see that the information from these two AR plots is consistent to the information in Figure 5.4a and Figure 5.4f, such as the avoidance of amplifying low-frequency harmonics and two stationary points when  $0 < \omega < \pi$ . But for the rest of the frequency spectrum, the performance of these two parameter settings (Figure 5.5a and Figure 5.5h) is not attractive. In plot Figure 5.5g, the DT / OUT policy performs relatively well both at low-frequencies and high-frequencies, but harmonic amplitudes are magnified for the rest of the frequency interval.

It is impressive that  $AR > 1$  for only a few frequencies in plot c) and d) at Figure 5.5. For example, in plot c),  $AR > 1$  only occurs between  $0 < \omega < 0.1$  radians per sample interval, and for the remaining of the frequency spectrum, the amplitude ratio is actually much smaller than unity. These two settings are from the bullwhip avoidance area in Figure 6b and 6c (the grey areas). A similar AR plot was noticed by Dejonckheere et al. (2003). However they used simple exponential smoothing and modified the OUT policy by adding a proportional feedback controller into the inventory and work-in-progress feedback loops to create a discrete time version of the IOBPCS model (Towill, 1982). Our results suggest that the Damped Trend forecasting mechanism could allow the OUT policy to avoid the bullwhip effect without the difficult and expensive modification to the OUT policy advocated by Dejonckheere et al. (2003). This is another important managerial insight.

By repeating our analysis (details omitted for brevity) for different lead-times we find that when  $T_p > 1$ , for low-frequency demands, the parametrical plane  $\phi > 1$  still can enable the

DT / OUT system to avoid the bullwhip effect as  $AR|_{\omega \rightarrow 0} < 1$ . For high-frequency demands, Table 5.2 detailed the bullwhip avoidance region in Figure 5.3a for different  $T_p$  when  $0 < \phi < 1$ . There is no change in the criteria of  $\{\alpha, \phi\}$  and the upper boundary of  $\beta$ . Only the lower boundary of  $\beta$  value will increase with the lead-time (see Figure 5.6). Because the upper boundary of  $\beta$ ,  $\frac{\phi-1}{\phi} < 0$ , it is easy to conclude when  $0 < \phi < 1$  the area of the parametrical plane that is able to avoid the bullwhip effect (in Figure 5.3a) will become smaller if the lead-time increases. When  $-1 < \phi < 0$ , the region within the parametrical plane where bullwhip is avoided (in Figure 5.3b) changes in a complex manner. It has different shapes when the lead-time changes from an odd number to an even number. When  $\phi < -1$ , the bullwhip avoiding areas of the parametrical plane for both low-frequency (Figure 5.2b, Figure 5.2c, Figure 5.2d) and high-frequency (Figure 5.3c) demand will disappear and reappear in sophisticated manners when the lead-time switches between an odd number and an even number.

$T_p$	$0 < \phi < 1, \frac{\phi-1}{\phi} < \alpha < 0, \text{ lower boundary} < \beta < \frac{\phi-1}{\phi}$
0	$\frac{-1-\phi}{\phi}$
1	$\frac{-1}{\phi}$
2	$\frac{-3-3\phi}{3\phi+4\phi^2+2\phi^3}$
3	$\frac{-2}{2\phi+\phi^2+\phi^3}$
4	$\frac{-5-5\phi}{5\phi+8\phi^2+6\phi^3+4\phi^4+2\phi^5}$

5	$\frac{-3}{3\phi + 2\phi^2 + 2\phi^3 + \phi^4 + \phi^5}$
6	$\frac{-7 - 7\phi}{7\phi + 12\phi^2 + 10\phi^3 + 8\phi^4 + 6\phi^5 + 4\phi^6 + 2\phi^7}$
7	$\frac{-4}{4\phi + 3\phi^2 + 3\phi^3 + 2\phi^4 + 2\phi^5 + \phi^6 + \phi^7}$
8	$\frac{-9 - 9\phi}{9\phi + 16\phi^2 + 14\phi^3 + 12\phi^4 + 10\phi^5 + 8\phi^6 + 6\phi^7 + 4\phi^8 + 2\phi^9}$
9	$\frac{-5}{5\phi + 4\phi^2 + 4\phi^3 + 3\phi^4 + 3\phi^5 + 2\phi^6 + 2\phi^7 + \phi^8 + \phi^9}$
10	$\frac{-11 - 11\phi}{11\phi + 20\phi^2 + 18\phi^3 + 16\phi^4 + 14\phi^5 + 12\phi^6 + 10\phi^7 + 8\phi^8 + 6\phi^9 + 4\phi^{10} + 2\phi^{11}}$
11	$\frac{-6}{6\phi + 5\phi^2 + 5\phi^3 + 4\phi^4 + 4\phi^5 + 3\phi^6 + 3\phi^7 + 2\phi^8 + 2\phi^9 + \phi^{10} + \phi^{11}}$
12	$\frac{-13 - 13\phi}{13\phi + 24\phi^2 + 22\phi^3 + 20\phi^4 + 18\phi^5 + 16\phi^6 + 14\phi^7 + 12\phi^8 + 10\phi^9 + 8\phi^{10} + 6\phi^{11} + 4\phi^{12} + 2\phi^{13}}$

Table 5.2 Bullwhip avoidance area in Figure 5.3a changes with different  $T_p$

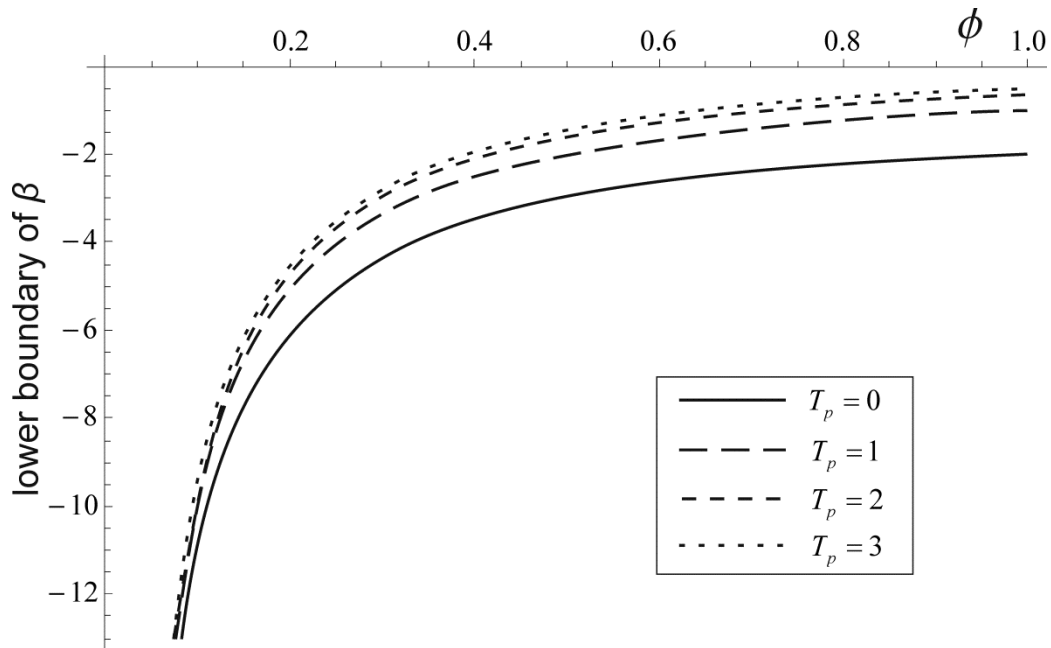

Figure 5.6 Lower boundary of  $\beta$  changes with  $T_p$

#### 5.4 Net stock amplification of the Damped Trend Order-Up-To system

Since the bullwhip avoidance areas have been revealed in the last section, this section will explore the net stock amplification (*NSAmp*) behaviour within these bullwhip avoidance areas. *NSAmp* is not a common supply chain measure, but it is related to the popular safety stock and fill rate concepts (Zipkin, 2000). We are particularly interested in the performance when the parameters select value from Table 5.2, because the DT / OUT system behaves like a low-pass filter.

Inspection of (5.11) shows that the inventory variance for i.i.d. demand is possible to be less than  $1+T_p$ . Disney and Towill (2003) show that in the OUT family, the first unit of inventory variance is because of the order of events. From (5.11) it is easy to spot this inherent behaviour as well. However, unlike the situations when other forecasting methods are used in OUT policy, DT forecasting sometimes produces a negative function after  $1+T_p$ , therefore enabling the OUT policy to create less inventory variance. That means when there is no lead-time, inventory levels is able to vary less than the variation in the demand signal. In other words, it is possible to achieve a near zero inventory policy. In addition, inventory variance increases as the lead-time increases.

Now we study the frequency response of the inventory variance. Assume  $\left| \frac{NS(e^{j\omega})}{\varepsilon(e^{j\omega})} \right| = AR_{ns}$ , then

$AR_{ns}|_{\omega \rightarrow 0} = 0$ , as  $\lim_{\omega \rightarrow 0} AR = 0$ , and the final value is

$$AR_{ns}|_{\omega=\pi} = \frac{\left| \begin{aligned} &(-2(1+(-1)^{T_p})(-1+\phi)^2(1+\phi) + \alpha(-1+(-1)^{T_p} + \\ &2T_p(1+(-1+\beta)\phi)(-1+\phi^2) + \phi((-1+(-1)^{T_p})(-1+(-1+\phi)\phi) + \\ &\beta(-1+(-1)^{T_p} + \phi(2-2(-1)^{T_p} + \phi(3+(-1)^{T_p} - 4\phi^{T_p})))) \end{aligned} \right|}{2(\phi-1)^2(2-\alpha+(2-\alpha-\alpha\beta)\phi)}. \quad (5.24)$$



The initial value suggests that for low-frequency demand, the DT / OUT policy is possible to avoid creating net stock variance amplification. When  $T_p = 1$ , the final value is  $2\alpha(1+\phi)(1+\beta\phi)/(\alpha-2+\phi(\alpha+\alpha\beta-2))$ , which is smaller than one if the parameters' values are from the bullwhip avoidance area in Figure 5.2 and Figure 5.3 (the light grey areas). This is suggesting that for the demand dominated by high-frequency harmonics, such as an AR(1) demand series with i.i.d. noise when the demand correlation is negative, once the DT / OUT system can not only avoid creating bullwhip, but most likely it would also reduce the amplification in net stock variance.

Figure 5.7 illustrates the frequency response plot of net stock using the same setting as in Figure 5.5c. It also acts as a low-pass filter, in which the low-frequency harmonic magnitudes will be amplified, but the net stock amplification will be avoided when high-frequency harmonics dominate the demand. More importantly, for general lead-time cases the final value of  $AR_{ns}$  is always less than unity as long as the  $\{\alpha, \beta, \phi\}$  is selected from Table 5.2. These suggest the bullwhip avoidance parameter settings given by  $\{0 < \phi < 1, \frac{\phi-1}{\phi} < \alpha < 0\}$  probably have a desirable frequency response in terms of both orders and net stock levels for any lead-time.

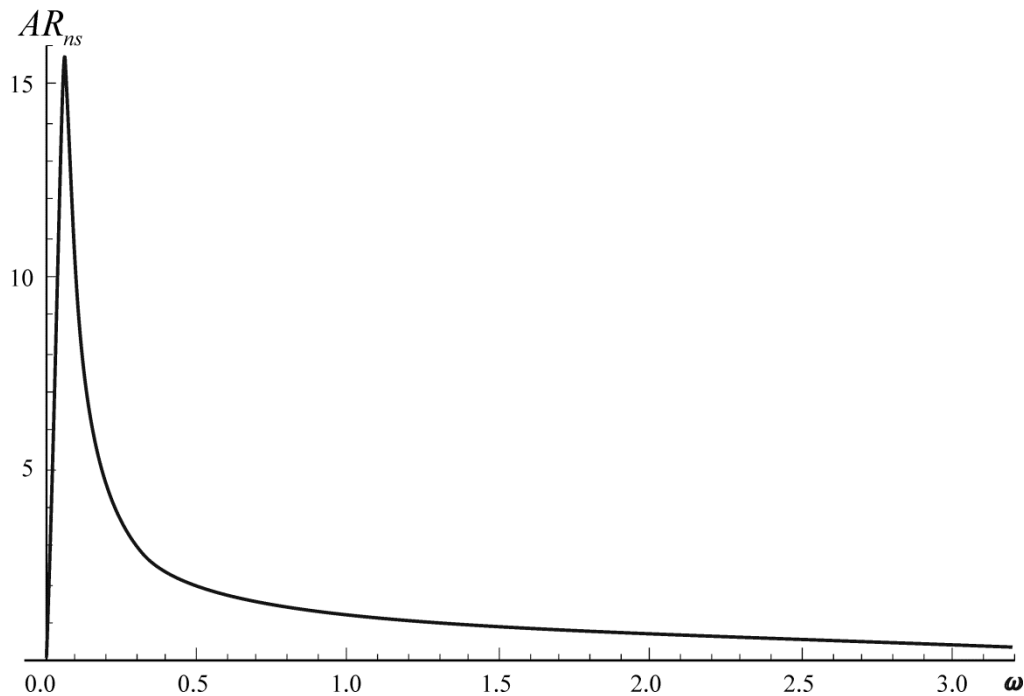

Figure 5.7 AR plot of NSamp when  $\phi = 0.5$ ,  $\alpha = -0.9$ ,  $\beta = -1.01$ ,  $T_p = 1$

## 5.5 Summary

In order to measure bullwhip or *NSamp* in supply chains for any possible demand pattern, an alternative method has been used, and a sufficient condition for bullwhip using AR has been explored. By studying the property of AR in both orders and net stock levels, some important insights have been explored and summarised:

1. We provided the new and complete proof to the conjecture in Dejonckheere et al. (2003) that OUT policy with Naïve, SES and Holts forecasts will always generate bullwhip for any demand patterns and all lead-times.
2. The traditional DT settings advocated in the literature when used in the OUT policy will always produce a bullwhip effect for any demand pattern, for all lead-times.
3. The DT / OUT policy cannot avoid amplifying individual harmonics for the whole range of the frequency spectrum, however there may or may not be a bullwhip effect for a particular demand pattern.

4. It is possible to avoid bullwhip effect for certain demand pattern using DT / OUT system. Both bullwhip avoidance area for low and high-frequency harmonics have been made explicit.
5. There are sophisticated odd-even effects in bullwhip avoidance behaviour.
6. It is also possible to avoid net stock amplification when the parameters are selected from some bullwhip avoidance areas. Especially, using parameter values from Table 5.2, the DT / OUT policy acts like a low-pass filter so that it is possible to reduce bullwhip and *NSAmp* at the same time.

Although the similar impressive bullwhip performance had been observed in Dejonckheere et al. (2003), our results suggest an important managerial insights that

*DT method could help the OUT policy eliminate the bullwhip effect without the difficult and expensive modification to the OUT policy proposed by Dejonckheere et al. (2003).*

In the next chapter, numerical investigations will be carried out to verify the theoretical findings revealed in this chapter.

## 6. Numerical Verification of the Damped Trend Order-Up-To Policy

The previous chapter proved analytically that the DT / OUT policy is able to avoid the variance amplification of orders and net stock for low and/or high frequency harmonics. For example, when the parameter set  $\{\alpha, \beta, \phi\}$  selects values from the light grey area in Figure 5.2, the DT / OUT will not create bullwhip for low-frequency signals. When parameter values are chosen from the light grey area in Figure 5.3, the system can reduce order amplification for high-frequency signals. The frequency response analysis also indicates that the DT / OUT system is able to reduce the net stock amplification for both low and high frequency harmonics if values from bullwhip avoidance area are applied. This implies that the DT / OUT policy may be able to reduce or avoid bullwhip and net stock amplification in practice for certain types of demand patterns.

This chapter will verify our analytical insights via simulation. First, section 6.1 will verify the high and low frequency behaviour of the DT / OUT system. In section 6.2, a simulation of the response to a real life demand pattern will be conducted to demonstrate the DT / OUT does indeed exhibit bullwhip avoidance behaviour in a practical setting. Then we will explore the bullwhip performance and the net stock amplification of the necessary conditions that we found in Chapter 5 given by  $\{0 < \phi < 1, \frac{\phi-1}{\phi} < \alpha < 0, \frac{\phi-1}{\phi} < \beta < \frac{-1}{\phi}\}$  with a grid search. This area was chosen as it was previously noted that it had a very desirable frequency response, acting like a low-pass filter. More real-life demand data series will be applied in section 6.3 with three different objectives. Section 6.4 summarises.

## 6.1 Verification of the low and high frequency harmonic behaviour of the Damped Trend Order-Up-To policy

In this section we will verify the avoidance of bullwhip and net stock amplification is possible when demand consists of a single harmonic frequency. This harmonic can be of a low frequency (to verify the bullwhip avoidance areas in Figure 5.2) or a high frequency (to verify the bullwhip avoidance areas in Figure 5.3). Specific considerations for *NSAmp* are not included in the section because the net stock variance will not be amplified in either case. We constructed an Excel based simulation of the DT / OUT policy with unit lead-time ( $T_p = 1$ ). Demand was assumed to be made up of a single sine wave with a mean of 10, unit amplitude and a frequency of  $\omega \in \{0.02, 3.1\}$  radians per period. We determined the bullwhip ratio,  $\sigma_o^2 / \sigma_d^2$ , and the net stock variance amplification ratio,  $\sigma_{ns}^2 / \sigma_d^2$ , from 4000 periods after an initialisation period of 1000 periods in order to avoid any transient responses produced by initial conditions.

Demand Frequency $\omega$ (radians per period)	0.02	0.02	0.02	0.02	3.1	3.1	3.1
$\alpha$	0.14	1.6	1.1	1.1	-0.5	2	1.4
$\beta$	0.14	1.6	1.1	1.1	-1	2	0.45
$\phi$	1.1	-1.5	-4.5	-5.5	0.6	-0.6	-2
Bullwhip $\sigma_o^2 / \sigma_d^2$	0.9768	0.9964	0.9824	0.9624	0.4278	0.5389	0.1697
<i>NSAmp</i> $\sigma_{ns}^2 / \sigma_d^2$	0.3626	0.0056	0.1781	0.8542	0.0309	0.0180	0.1997
Bullwhip avoidance area in Figure	5.2a	5.2b	5.2c	5.2d	5.3a	5.3b	5.3c

Table 6.1 Numerical results from a 4000 period simulation verifying theoretical results

Sample numerical results are given below in Table 6.1. These values of  $\alpha$ ,  $\beta$  and  $\phi$  were chosen because they lie in each of the bullwhip avoidance regions in Figure 5.2 and Figure 5.3. They verify the theoretical investigations in the previous chapter that the OUT policy with DT forecasting can indeed eliminate the bullwhip effect and avoid net stock variance amplification when demand is a single harmonic frequency.

## 6.2 Application to a real-world data set

To verify our theoretical and numerical results in practice, we selected a real-life data set (consisting of 128 daily demand values) placed on a manufacturer of fast moving consumer goods in the household goods category from a UK supermarket chain. This is the same demand pattern used in Dejonckheere et al. (2003). Interestingly it contains an upward trend followed by a downward trend and another upward trend. In the middle of this sequence there is also a significant short-lived spike in demand. We assumed the lead-time  $T_p = 1$ , which matched the real-life scenario.

The original demand pattern is decomposed into 64 harmonic frequencies via the Fast Fourier Transform (FFT). The FFT is a computational tool which facilitates signal analysis and efficiently computes the Discrete Fourier Transform of a time series. It can be found as a built-in function in Microsoft Excel. It is an easy task to calculate the amplitude and phase of each harmonic frequency and identify dominant frequencies in the spectrum. Figure 6.1 shows the amplitude of the harmonic cosine waves that make up the original demand pattern. We see that there is dominant frequency of  $\frac{\pi}{64}$  radians per period but there are also a number of significant frequencies across the whole range. This information suggests that we are looking for an OUT policy frequency response that has a similar shape to the plot c) in Figure

5.5. This occurs in the region of  $\{0 < \phi < 1, \frac{\phi-1}{\phi} < \alpha < 0, \frac{\phi-1}{\phi} < \beta < \frac{-1}{\phi}\}$ , the area we previously identified as having the characteristics of a low-pass filter.

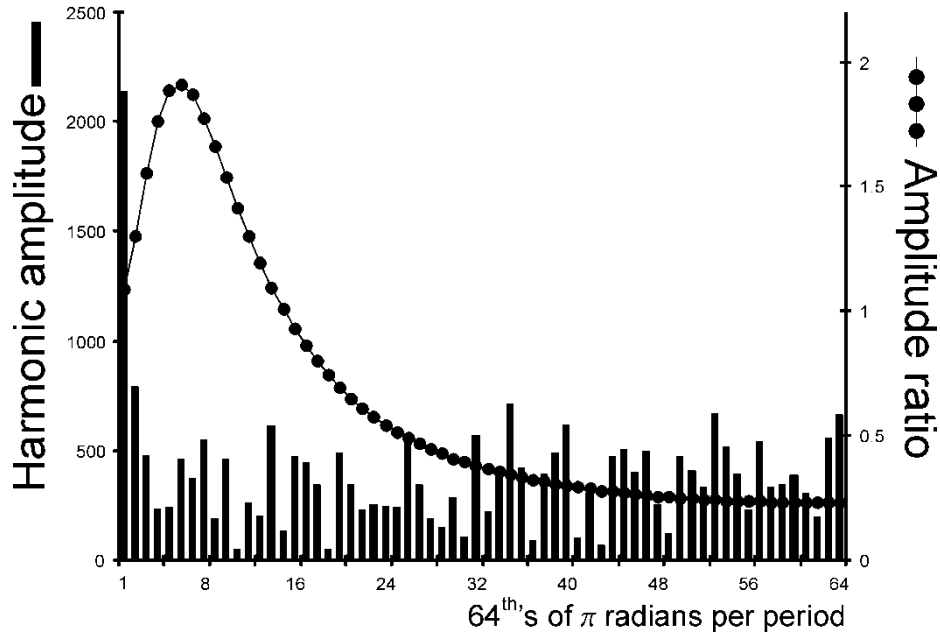

Figure 6.1 FFT analysis of the demand for a FMCG in the household goods category

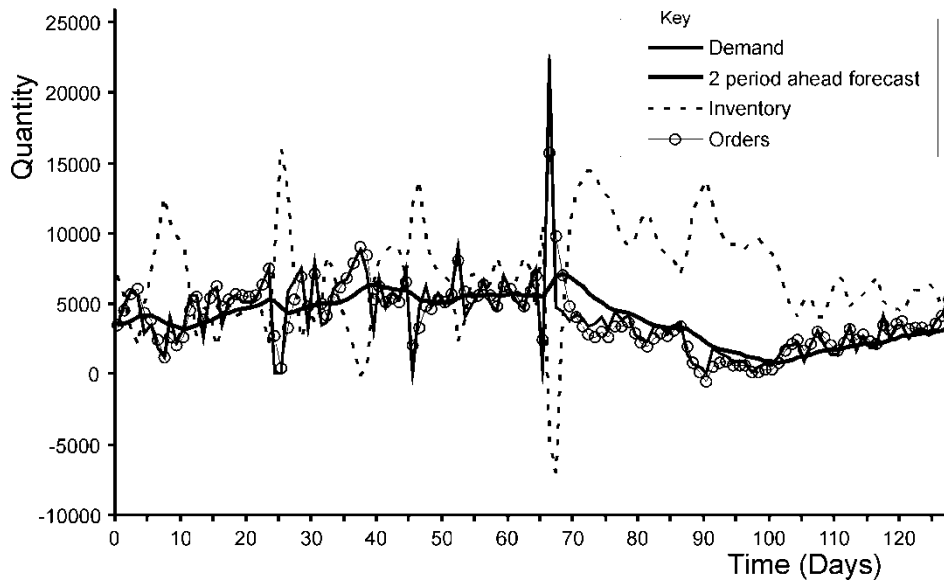

Figure 6.2 Simulated response by the OUT policy with DT forecasts

After some exploration of suitable parameter sets in this area we settled  $\{\phi = 0.077, \alpha = -5.695, \beta = -12.13\}$  as it had both good bullwhip avoidance behaviour and maintained good control over the inventory levels. From the Excel simulation the bullwhip

ratio obtained was  $\frac{\sigma_a^2}{\sigma_d^2} = 0.767727$  and the net stock variance ratio was  $\frac{\sigma_m^2}{\sigma_d^2} = 1.867$ . Figure 6.2 gives a summary time plot of the demand, the two-period ahead forecast, the production orders and the inventory levels maintained by the OUT policy with DT forecasts. We are pleasantly surprised at how well the inventory levels are maintained around the Target Net Stock of 7000.

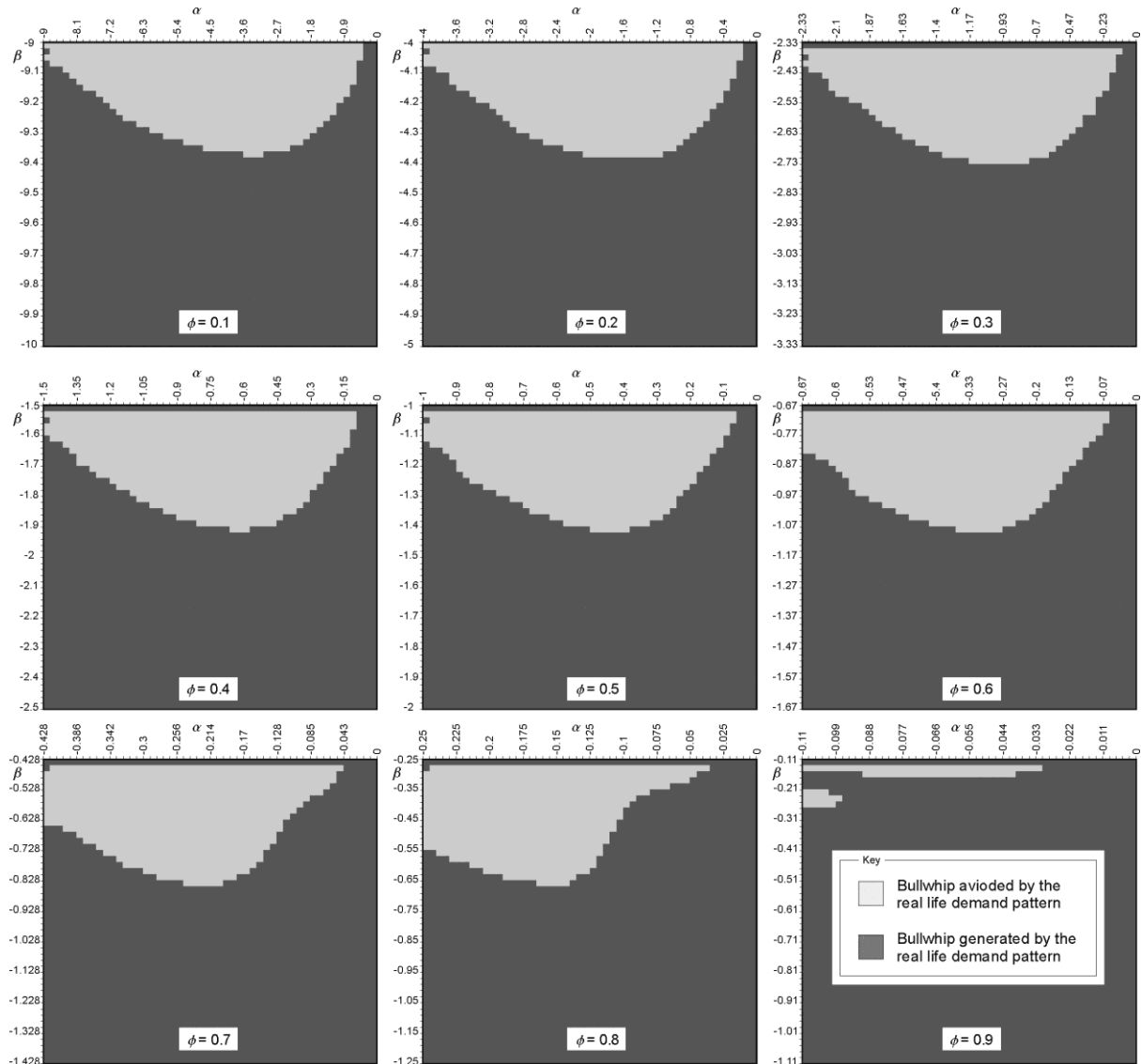

Figure 6.3 Investigation of the performance of the necessary bullwhip criterion

A grid search of the DT / OUT policy with  $T_p = 1$  reacting to the real-life demand pattern in Figure 6.1 is conducted. The grid search explored the low pass filter area given by



$\{0 < \phi < 1, \frac{\phi-1}{\phi} < \alpha < 0, \frac{\phi-1}{\phi} < \beta < \frac{-1}{\phi}\}$  for different values of  $0.1 \leq \phi \leq 0.9$  in steps of 0.1. The stable range of  $\alpha$  and  $\beta$  was divided up into 50 increments. From Figure 6.3, we can see the necessary conditions, for this particular demand pattern, resulted in bullwhip avoidance for about 20% of the possible cases. Interestingly, in order to avoid bullwhip,  $\alpha$  should be selected in the mid-range of its stability region and  $\beta$  should be selected in the high (least negative) end of its stability region. This suggests that the forecasting parameters need to be carefully matched to the demand process.

Similarly, the grid search is conducted in the same region to explore the behaviour of  $NSAmp$  using the exactly same setting we used before. Figure 6.4 demonstrates that when  $\alpha$  is selected from the middle to the less negative value of the valid range, there is a range of stable  $\beta$  settings that is able to achieve  $NSAmp < 2$  when  $T_p = 1$ . This is consistent to the analytical finding that the DT / OUT policy is able to reduce the  $NSAmp$  to be smaller than  $T_p + 1$ . Considering the fact that the bullwhip effect can be eliminated in some regions mentioned above, for this particular demand pattern, by setting  $\phi$  away from one,  $\alpha$  in middle range and  $\beta$  close to the high end, it is possible to obtain a system that produces no bullwhip and exhibits good control over inventory levels. This suggests that practitioners should carefully match parameter values to not only demand patterns but also to their business objectives.

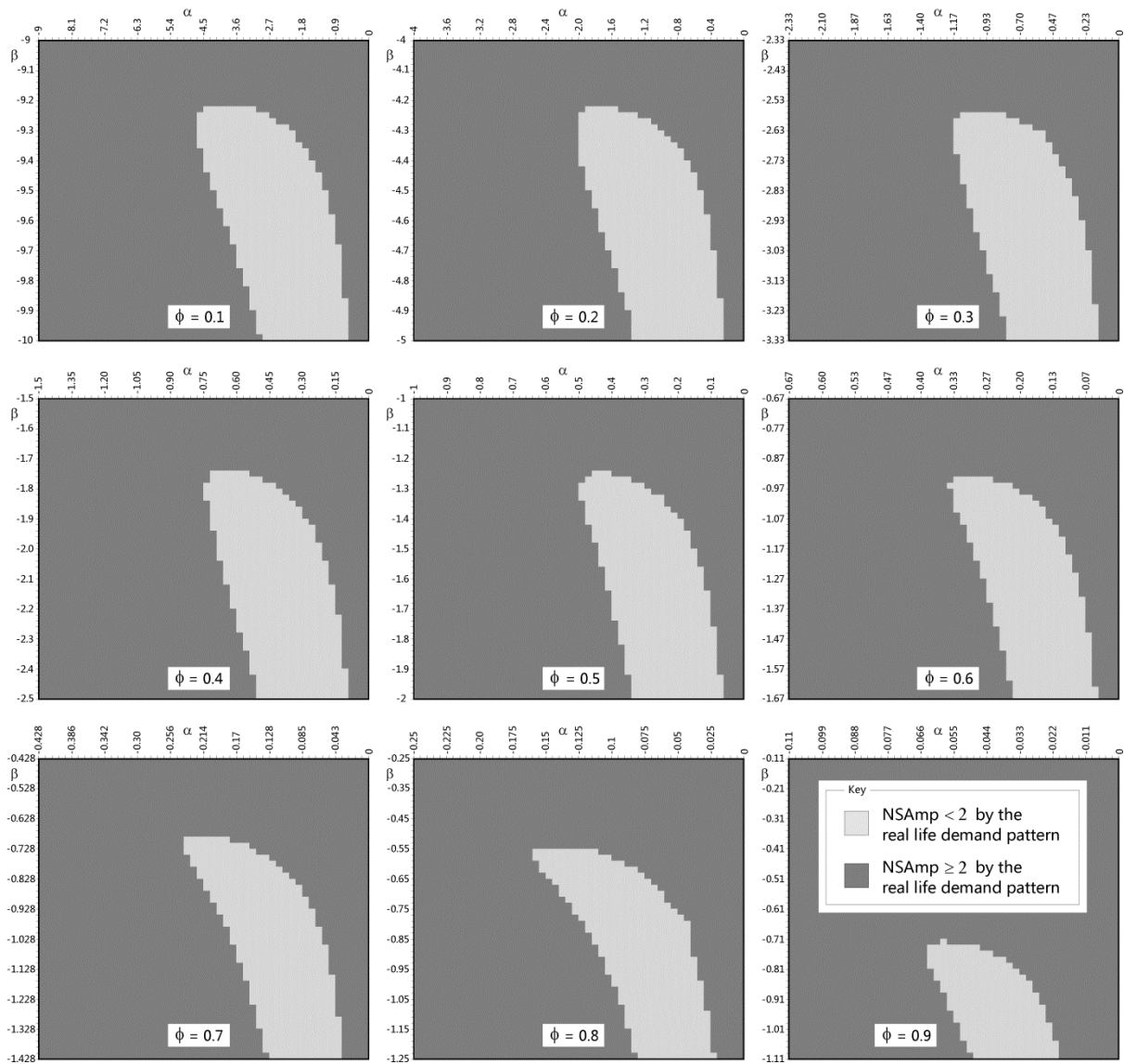

Figure 6.4 Investigation of NSamp

### 6.3 Analysis of 62 real-world demand data sets

In this section, more real-life demand data will be explored to verify our analytical results. These demand series came from previous research and projects conducted by the members of Logistics Systems Dynamics Group, Cardiff Business School. There are low-volume products as well as high volume products. The source of the data ranges from retailers, manufacturers, to logistics companies and distributors. The property of the series are analysed

and summarised in Table 6.2. Any series for intermittent demand are not selected in this research, as exponential smoothing family is not appropriate in this case.

No.	Products	Description of demand series		
		Trend(s)	Seasonality	Outliers(s)
1	grocery product	×	×	√
2	grocery product	×	√	√
3	grocery product	×	×	√
4	grocery product	×	×	√
5	grocery product	×	×	√
6	grocery product	×	√	×
7	grocery product	×	√	√
8	grocery product	×	×	√
9	grocery product	×	√	×
10	steel repeater	×	×	√
11	grocery product	√	×	×
12	grocery product	×	×	×
13	grocery product	×	√	×
14	grocery product	×	√	×
15	grocery product	×	√	×
16	grocery product	×	√	×
17	grocery product	×	√	×
18	grocery product	×	√	×
19	grocery product	×	√	×
20	grocery product	×	√	√
21	grocery product	×	√	×
22	grocery product	×	√	×
23	grocery product	√	√	×
24	grocery product	×	×	√
25	grocery product	×	√	√
26	grocery product	×	√	×
27	grocery product	×	√	×
28	grocery product	×	√	×
29	grocery product	×	√	×
30	grocery product	×	√	√
31	grocery product	√	√	×
32	grocery product	×	√	×
33	grocery product	√	×	×
34	grocery product	√	×	√
35	paper product	√	×	×
36	transport	×	√	√

37	grocery product	√	√	×
38	grocery product	√	×	×
39	grocery product	√	√	×
40	grocery product	×	√	×
41	grocery product	√	×	×
42	grocery product	√	×	×
43	grocery product	√	×	×
44	grocery product	√	×	×
45	grocery product	×	√	√
46	grocery product	√	√	×
47	grocery product	√	×	√
48	printers	×	×	×
49	grocery product	√	√	×
50	pumps	√	×	×
51	chocolate	√	×	×
52	car stereos	×	×	√
53	homecare product	√	×	×
54	homecare product	√	×	√
55	apple juice (pack of 4)	×	×	√
56	orange juice (pack of 6)	×	×	√
57	apple juice	×	√	×
58	orange juice (pack of 4)	×	×	√
59	orange juice	×	×	√
60	apple juice	×	×	√
61	orange juice	×	√	×
62	value pack orange juice	×	×	√

Table 6.2 Description of 62 real-world data sets

These 62 real-life demand series are first decomposed into frequency harmonics by the FFT. Figure 6.5 illustrates each data set in both the time and frequency domain via a plot of amplitudes obtained from the FFT. It is easy to notice that the majority of them are dominated by low-frequency harmonics as the previous example, except for series 55, 56, 58, 59 and 62. In order to reduce the computing time, we narrowed down the search range to the desirable region explored in the previous section, as within this area the DT / OUT system is most likely to have both good bullwhip performance and net stock performance. The area is

$$\left\{0 < \phi < 1, \frac{\phi-1}{\phi} < \alpha < 0, \frac{\phi-1}{\phi} < \beta < \frac{-1}{\phi}\right\}.$$

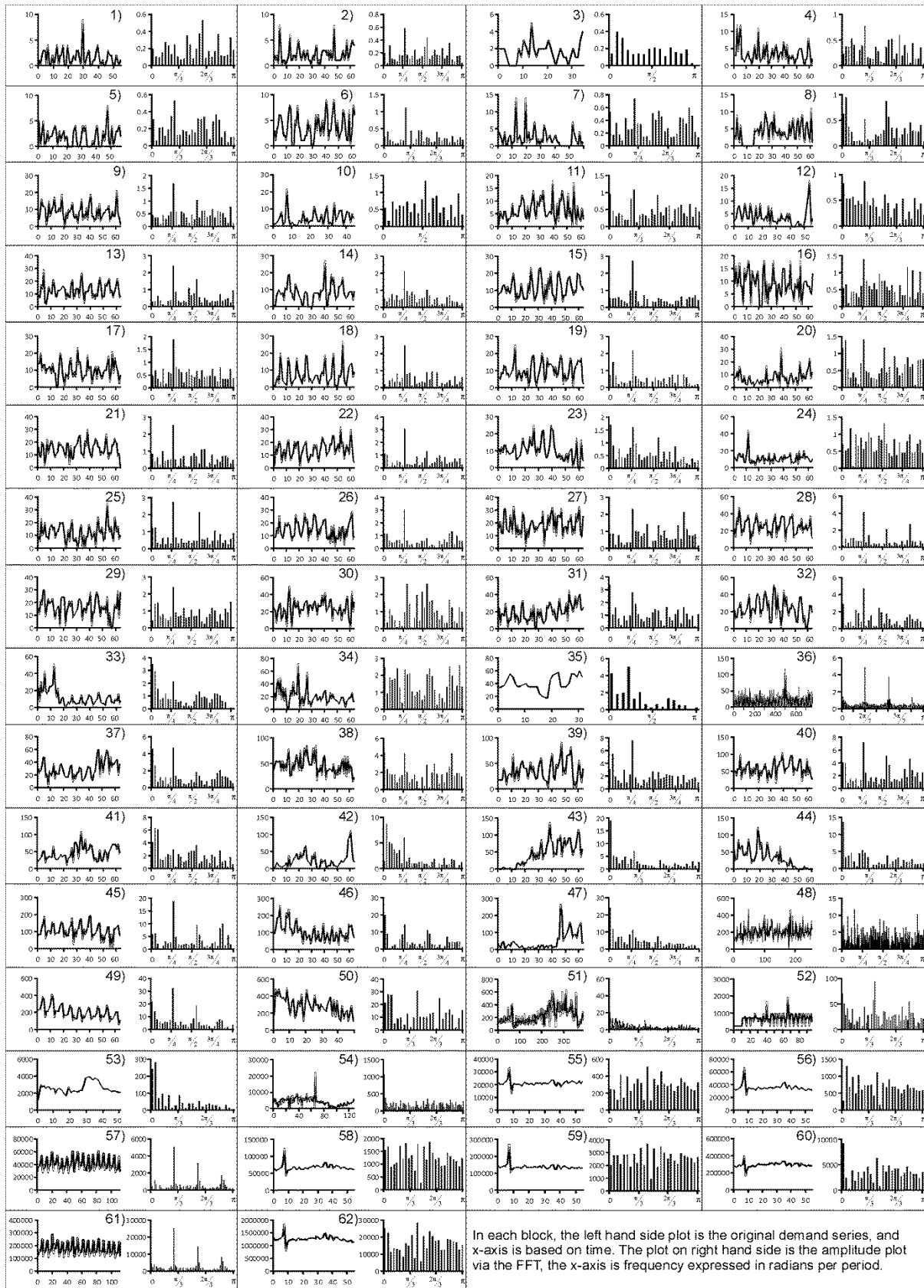

Figure 6.5 Illustration of 62 real-world data sets

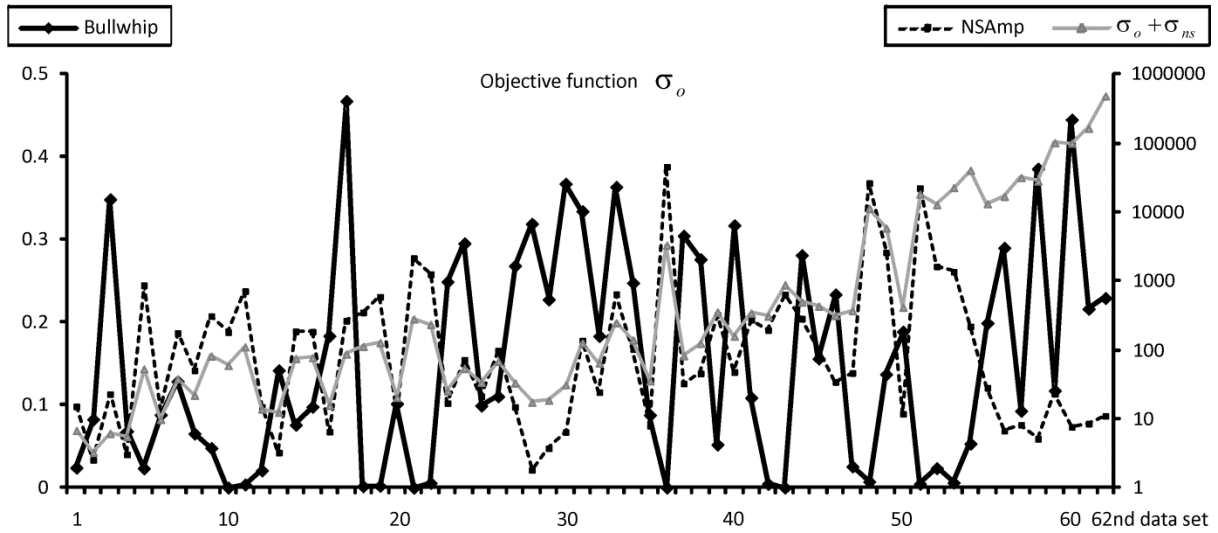

Figure 6.6 The bullwhip and NSamp when the objective is to minimise  $\sigma_o$

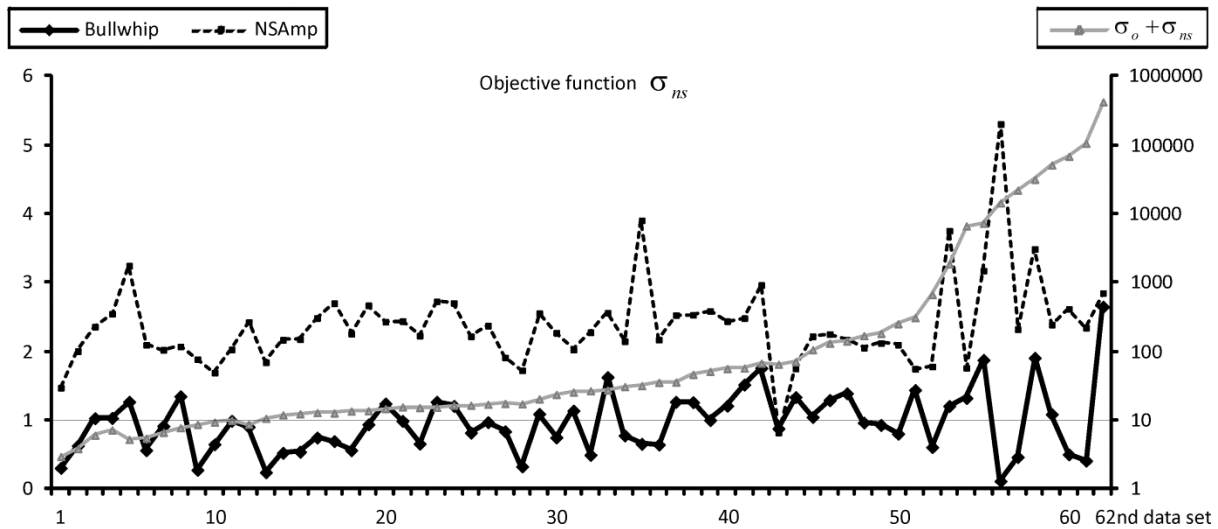

Figure 6.7 Bullwhip and NSamp when objective function is to minimise  $\sigma_{ns}$

A numerical optimisation based on minimising  $\sigma_o$ ,  $\sigma_{ns}$  and  $\sigma_o + \sigma_{ns}$  separately is first explored. The first objective is to minimise the standard deviation of the orders, in other words, it is able to reduce the bullwhip effect. The second objective is to minimise the standard deviation of net stock. The standard deviation of net stock is considered because it is closely related to the safety stock a company must hold in inventory to minimise holding and backlog costs. Therefore, a minimised  $\sigma_{ns}$  is able to reduce inventory costs and will also improve service level for a given safety stock. The last objective considers the situation that a

company might focus on both the capacity costs and inventory costs. Then we arbitrarily assume the standard deviation of inventory and the standard deviation of orders are equally costly.

Figure 6.6 and Figure 6.7 summarise the bullwhip ratio, *NSAmp* ratio, and  $\sigma_o + \sigma_{ns}$ , when the objective function is to minimise  $\sigma_o$  and  $\sigma_{ns}$  accordingly. Usually, there is a trade-off between bullwhip and net stock amplification in supply chains. When the objective is to minimise  $\sigma_o$ , the OUT policy with DT forecasting mechanism successfully avoids the bullwhip effect in all the 62 time series but sometimes at the expense of a large amplification in net stock variance (Figure 6.6). Despite the fact that some bullwhip ratios are close to zero, the bullwhip performance cannot achieve the same level as the model advocated by Dejonckheere et al. (2003) which can reduce order variance (and hence the bullwhip ratio) down to zero.

Nevertheless, even when we are minimising  $\sigma_{ns}$  (Figure 6.7), some parameter settings within that area can still eliminate the bullwhip effect in 35 of the 62 real-life data sets. For those scenarios which cannot avoid bullwhip, the majority of the bullwhip ratios were still maintained near one. This might suggest that the DT / OUT system can keep good control of inventory costs and service levels without inducing significant capacity costs. Managers only need to consider minimising the standard deviation of inventory when inventory costs are more significant than capacity costs in their supply chains, as this will simultaneously generate the best inventory performance and relatively good bullwhip behaviour.

If inventory costs and capacity costs are considered equally important, the empirical results show that the DT / OUT policy successfully eliminated the bullwhip effect in 52 out of 62 time series when the objective is to  $\min(\sigma_o + \sigma_{ns})$  (see Figure 6.8). Observing the optimised

parameters, we notice that only a few optimised  $\phi$  values are close to one. The majority of the optimised  $\alpha$  and  $\beta$  parameters have less negative values, which is consistent with the findings in the previous section.

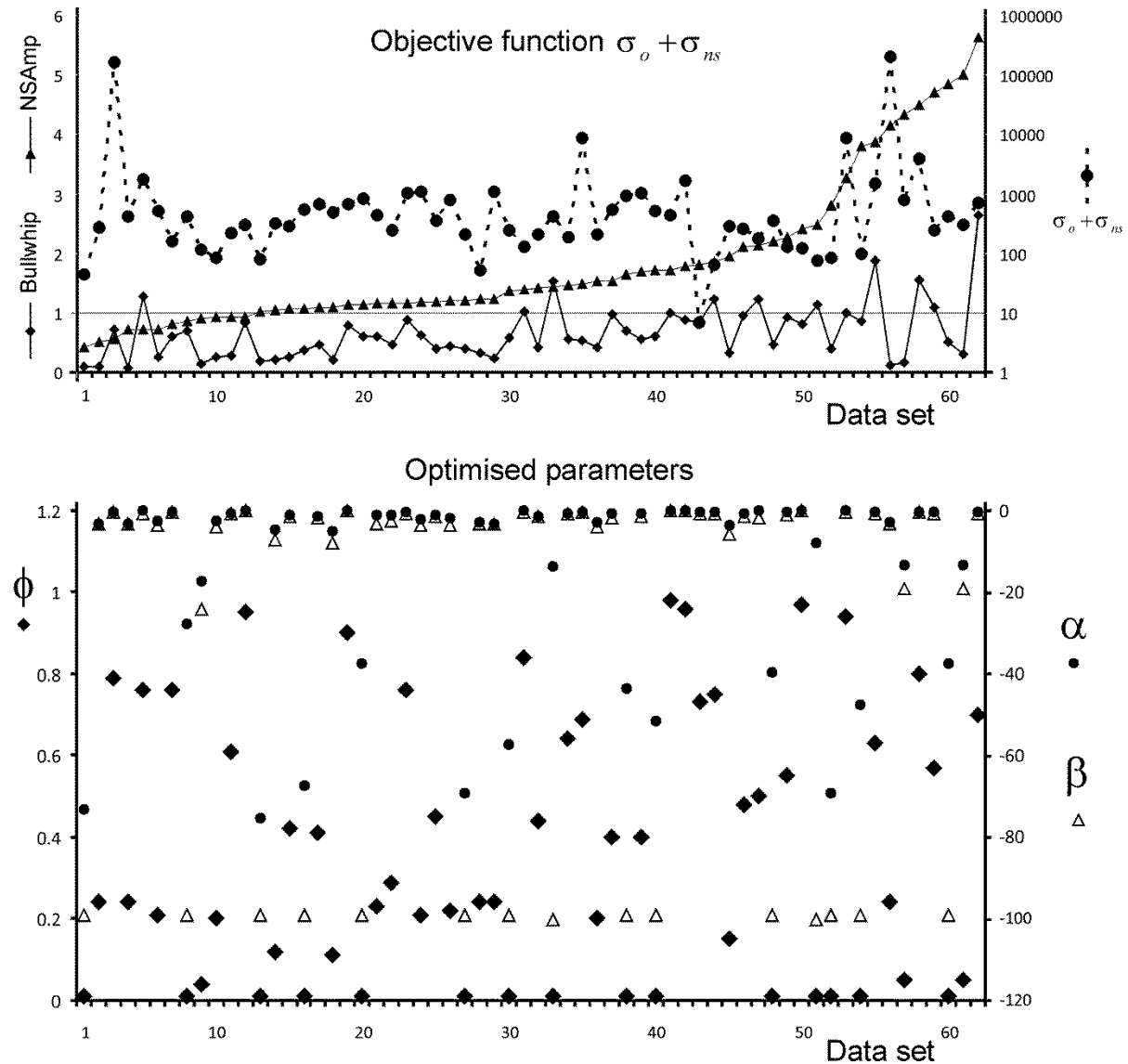

Figure 6.8 Bullwhip and NSAmP of 62 real-world data sets when  $\sigma_o + \sigma_{ns}$  is minimised, together with the optimisation forecasting parameters

It is easy to notice that the procedure of the numerical analysis is different to the traditional forecasting application process. Compared to the traditional process, there is no stage of model identification involved; outliers are not excluded from the demand series; and we didn't deseasonalise data. A typical example can be found in the demand series 7, a seasonal



data with outliers. All these demand properties were still embodied in the analysis. This is because the selection of parameter values is based on the business objectives rather than measures of forecasting performance.

Traditional forecasting practice would reject the outlier from the series 7 and deseasonalise the data. Then, this demand series would become a level series with random noise. Thus, if Damped Trend forecasting method is applied to produce forecasts, the value of  $\phi$  would be zero as there is no trend at all and simple exponential smoothing method is the most suitable forecasting method. When  $\phi$  uses conventional values, like the zero value in this case, it always induce bullwhip. However, in our analysis, the optimised  $\phi$  value is 0.76. If we choose the unconventional values revealed in this research, it is possible to reduce bullwhip to 0.607 and net stock amplification to 2.208 when we are optimising  $\sigma_o + \sigma_{ns}$ . Less bullwhip and less net stock amplification concur with business's interests in production planning and inventory control better than forecast accuracy does, because focusing on forecasting accuracy in this case will never achieve the same level of performance. At this point it is interesting to recall what Makridakis et al. (1983) suggested, 'it is management's knowledge and use of existing methods, in their specific organizational context, that hold the greatest promise'.

## 6.4 Summary

This chapter verified the theoretical insights by numerically exploring real-life demand data. When demand consists of individual low- or high-frequency harmonics, the DT / OUT system clearly demonstrates that the bullwhip effect can be eliminated. The parameter values in the demonstration were selected from all the areas identified in the previous chapter that

are able to reduce bullwhip. We also show that within the bullwhip reduction area, the net stock amplification can also be reduced; the *NSAmp* measure for a single harmonic frequency can unsurprisingly be smaller than one.

Simulating the real-world demand patterns further validated the theoretical results from the previous chapters. First, the same demand used in Dejonckheere et al. (2003) was decomposed into harmonic frequencies via the FFT. After analysing the harmonic frequencies of demand, it was considered wise to utilise the parameter values from the  $\{0 < \phi < 1, \frac{\phi-1}{\phi} < \alpha < 0, \frac{\phi-1}{\phi} < \beta < \frac{-1}{\phi}\}$  region. The behaviour of DT / OUT in this area is akin to a low-pass filter. For this demand pattern, the OUT policy is able to reduce bullwhip to 0.77, and to reduce net stock amplification to 1.87, when the lead-time is one. This level of performance cannot be achieved by when the Naïve, SES or the Holts forecasting method is used in the OUT policy. A grid search also proved that there are regions which are able to achieve no bullwhip and less *NSAmp*. Therefore, an important managerial implication is that:

*When practitioners carefully choose forecasting parameter values to match the demand pattern and their business objective, significant benefits can occur.*

## **7. System Nervousness**

Previous chapters used control theory technique to investigate the system dynamics produced by the DT / OUT policy for general demand cases. In this chapter, another aspect – system nervousness – is considered together with the bullwhip effect and other traditional supply chain dynamics metrics. As there is no research considered such a situation, this chapter considers a relatively simple demand pattern (auto-regressive random demand of the first order, AR(1)) rather than the general demand assumption in Chapter 4, 5, and 6. The chapter is also different with previous chapters by using time series analysis method rather than transforms, and by considering a two-echelon supply chain rather a single echelon production and inventory control system.

The practice of issuing call-offs and order forecasts is common in automotive, electronics and manufacturing industries (Harrison, 1997). A real-life example of system nervousness was already introduced in Chapter 1 Table 1.1. These call-off orders and order forecasts are usually produced by downstream players, and then passed upstream to their suppliers. In each replenishment cycle (of usually a week, but it could be as short as a few hours, or as long as a month or so), a firm order is given suppliers instructing them of how much to dispatch in the current period, as well as some future guidance of the likely (but not guaranteed) orders in the future. Suppliers do not necessarily produce their own forecasts; they can use this future guidance to initiate production, procure raw materials and components, and to plan labour and capacity acquisitions. Often they use MRP systems to facilitate this task, especially when many products and components are present.

However, this practice will often leads to a distressing situation that many companies will experience both system nervousness and bullwhip simultaneously. This chapter returns to the essence of the system nervousness problem from a dynamic supply chain management perspective. It investigates how to produce more reliable future order forecasts so as to relieve both system nervousness and the bullwhip effect. It also highlights a mechanism that is able to eliminate the bullwhip effect, as well significantly reduce system nervousness problem. To the best of the author's knowledge, there are no previous studies that have considered both the system nervousness and bullwhip problems together.

The structure of this chapter is as follows. Section 7.1 describes three different scenarios for generating order call-offs and order forecasts based on the order-up-to (OUT) policy, a popular replenishment algorithm in high volume industries and present in many commercial MRP systems. Section 7.2 discusses how to measure nervousness and presents analytical expressions for the accuracy of the order streams in each scenario via time series analysis method. Section 7.3 derives managerial insights from the analytical results. We conclude in Section 7.4.

## **7.1 Methods to generate future guidance**

We investigate a two-echelon supply chain with a single retailer and single a manufacturer<sup>1</sup>. We explore whether or not the POUT policy, so powerful at eliminating the bullwhip effect (Disney et al., 2004), is able to help the manufacturer forecast orders more accurately and reduce system nervousness. We then propose a new method to generate the order forecasts by

---

<sup>1</sup> Note, the retailer could be a retailer, distributor, manufacturer (or the manufacturer a supplier etc.), but we use the terms as "retailer" is easily recognised as the downstream player and the "manufacturer" is easily recognised as the upstream player. We assume that both players are motivated to minimise both capacity (bullwhip) related costs and inventory costs.

accounting for the future impact of the proportional controller. We will show that this new method is able to reduce system nervousness and eliminate the bullwhip effect.

Let the list of  $(m+1)$  items,  $\{o_t, \hat{o}_{t,t+1}, \hat{o}_{t,t+2}, \dots, \hat{o}_{t,t+j}, \dots, \hat{o}_{t,t+m}\}$ , be the information given to the manufacturer by the retailer in each period. The first item,  $o_t$ , is the call-off order that the retailer places to the manufacturer at time  $t$ .  $\hat{o}_{t,t+j}$  is the prediction made by the retailer of the order quantity  $o_{t+j}$  that the manufacturer will actually receive  $j$  periods later.  $j \in \mathbb{N}^+ \leq m$  where  $m$  is linked to the length of the manufacturer's planning horizon, perhaps the longest lead time that the manufacturer faces. From experience, in a weekly planning system,  $m$  is usually 13 or 26 weeks and the order forecasts near the horizon may be aggregated into monthly buckets.

Due to demand uncertainty and forecast errors, future call-off orders could be different to the guidance previously provided. The mean squared difference between the call-off order and the order forecast over the horizon is a measure of the accuracy of the future guidance and we assume this is a measure of the system nervousness problem. We consider three different scenarios for generating the call-off order and the order forecasts, all based on the OUT policy.

### 7.1.1 Scenario A: The order-up-to (OUT) replenishment policy

We assume in Scenario A, as is typical in many high volume industries, that the OUT policy is used to determine the call-off order. The OUT policy is given by

$$o_t = \hat{d}_{t,t+T_p+1} + tns - ns_t + \sum_{i=1}^{T_p} (\hat{d}_{t,t+i} - o_{t-i}). \quad (7.1)$$

In (7.1),  $o_t$  is the order placed at time  $t$ ,  $T_p \in \mathbb{N}^0$  is the replenishment lead time,  $\hat{d}_{t,t+T_p+1}$  is a forecast of demand, made at time  $t$  of demand in  $T_p + 1$  periods ahead.  $tns$  is the target net stock, a time invariant safety stock that can be set to minimise inventory holding and backlog costs via the newsvendor principle (Hosoda and Disney, 2009).  $ns_t$  is the net stock at time  $t$ . A positive net stock denotes inventory holding, a negative net stock denotes a backlog position. The final component of (7.1) is a sum of the forecasted demand over the lead time  $T_p$ , which acts as a desired work-in-progress ( $dwip_t = \sum_{i=1}^{T_p} \hat{d}_{t,t+i}$ ) and the open orders, the orders placed but not yet received, or actual work-in-progress ( $wip_t = \sum_{i=1}^{T_p} o_{t-i}$ ). The inventory balance equation,  $ns_t = ns_{t-1} + o_{t-T_p-1} - d_t$  completes the system.

We also assume in Scenario A that a forecast of demand is used to predict future orders,

$$\hat{o}_{t,t+j} = \hat{d}_{t,t+T_p+1+j}, \quad j \in \mathbb{N}^+ \leq m. \quad (7.2)$$

### 7.1.2 Scenario B: The proportional order-up-to replenishment policy

In our second scenario, the retailer implements a proportional OUT (POUT) policy. The POUT policy is a generalisation of the OUT policy that incorporates a proportional feedback controller to the inventory position feedback loop. This has become a popular replenishment policy recently due to its ability to eliminate the bullwhip effect in supply chains (Disney and Towill, 2005) and has been implemented in Tesco (Potter and Disney, 2010) and Lexmark (Disney et al., 2013). The retailer, Tesco, was interested in eliminating the bullwhip effect as excessive bullwhip creates a fluctuating workload in the profile of warehousing and transportation activities over the week. The manufacturer, Lexmark, was interested in eliminating the bullwhip effect as it causes over-time and lost capacity in its factories. A

comprehensive study of ordering policies with proportional feedback controllers can be found in Lalwani et al. (2006).

The call-off order quantity generated by the POUT policy is given by

$$o_t = \hat{d}_{t,t+T_p+1} + \frac{1}{T_i} \left( tns - ns_t + \sum_{i=1}^{T_p} (\hat{d}_{t,t+i} - o_{t-i}) \right), \quad (7.3)$$

where all the notation is the same as for the previously defined OUT policy, except for the introduction of the proportional feedback controller,  $T_i$ . For stability, Disney (2008) shows that  $0.5 < T_i < \infty$  is required. Equation (7.1) is a special case of (7.3) with  $T_i = 1$ . The predicted orders in Scenario B are defined by (7.2). The POUT policy (7.3) is able to reduce the bullwhip effect in the supply chain when  $T_i > 1$  as

$$\sigma_o^2 = \sigma_d^2 / (2T_i - 1), \quad (7.4)$$

for i.i.d. demand with MMSE forecasting (Disney et al., 2004). For arbitrary demand when  $T_i = \infty$  then the variance of the orders equals the variance of the forecasted demand,  $\sigma_o^2 = \sigma_d^2$ . If the demand forecasts are a constant (say  $\forall x, \hat{d}_{t,t+x} = \mu$  where  $\mu$  is the mean demand), then  $\sigma_o^2 = \sigma_d^2 = 0$ . The impact of the feedback controller on system nervousness has not been studied before.

### 7.1.3 Scenario C: The POUT policy with damped future order guidance

In Scenario C the call-off orders are generated with (7.3) as in Scenario B. However, we devise a new method for generating the future guidance that is based on known future corrections to the current inventory position,

$$\hat{o}_{t,t+j} = \hat{d}_{t,t+T_p+1+j} + \frac{1}{T_i} \left( \frac{T_i-1}{T_i} \right)^j \left( tns - ns_t + \sum_{i=1}^{T_p} \left( \hat{d}_{t,t+i} - o_{t-i} \right) \right), \quad T_i \neq 1. \quad (7.5)$$

Notice that Scenario B only utilised the demand forecasts to generate the future order guidance. However, the proportional future guidance (PFG) strategy accounts for the future consequences of the proportional feedback controller by adding them to the demand forecast. The table below summarises the three scenarios.

System Component	Scenario A	Scenario B	Scenario C
Call-off order	Order-up-to policy (OUT)	Proportional order-up-to policy (POUT)	Proportional order-up-to policy (POUT)
Order forecast	Demand forecast	Demand forecast	Demand forecast plus an account for the known future impact of the POUT policy, a.k.a. proportional future guidance (PFG)

Table 7.1 Summary of the three scenarios

## 7.2 Measuring system nervousness: The accuracy of the future guidance

In this section we explore an accuracy measurement for the future guidance. The more accurate the future guidance, the less system nervousness is present, and the easier it will be for companies to organise their activities to meet future demand. No matter how the future guidance is generated, the following order matrix always exists,

$$\begin{pmatrix} o_0 & \hat{o}_{0,1} & \cdots & \hat{o}_{0,j} & \cdots & \hat{o}_{0,m} \\ o_1 & \hat{o}_{1,2} & \cdots & \hat{o}_{1,1+j} & \cdots & \hat{o}_{1,1+m} \\ \vdots & \vdots & \ddots & \vdots & \ddots & \vdots \\ o_{t-j} & \hat{o}_{t-j,t-j+1} & \cdots & \hat{o}_{t-j,t} & \cdots & \hat{o}_{t-j,t-j+m} \\ \vdots & \vdots & \ddots & \vdots & \ddots & \vdots \\ o_t & \hat{o}_{t,t+1} & \cdots & \hat{o}_{t,t+j} & \cdots & \hat{o}_{t,t+m} \end{pmatrix}. \quad (7.6)$$



Let the difference between the  $j$ -step ahead forecasted order information produced at time  $t - j$  and the real order placed at time  $t$  be the “order forecast” error,

$$\delta_t = \hat{o}_{t-j,t} - o_t. \quad (7.7)$$

There are  $m \times t$  order forecast errors in the matrix. We can sum all of the  $m$  mean squared order forecast errors,

$$\Delta = \sum_j \left( \lim_{T \rightarrow \infty} \frac{\sum_t \delta_t^2}{T} \right) = \sum_{j=1}^m \left( \lim_{T \rightarrow \infty} \left( \sum_{t=0}^T (\hat{o}_{t-j,t} - o_t)^2 / T \right) \right), \quad (7.8)$$

to evaluate the accuracy of the future guidance over a time horizon of  $m$  periods. The performance of the future guidance generating mechanism should be time invariant if demand is stationary. A minimum  $\Delta$  also indicates the most accurate order forecasts over  $m$  periods. This will also coincide with the least nervous future order stream. Note that in the equation (7.8),  $\Delta[j] = \lim_{T \rightarrow \infty} \left( \sum_{t=0}^T (o_{t-j,t} - o_t)^2 / T \right)$  indicates the variance of the  $j$  period ahead order forecast error  $\delta_t$  when  $\varepsilon_t$  is replaced with a unit impulse. It is not difficult to quantify  $\Delta$  in all three scenarios, as shown in Chapter 11.

### 7.2.1 The case of the auto-regressive demand pattern

From this point we will investigate the behaviour of the three scenarios under the assumption that the retailer faces an auto-regressive random demand of the first order, AR(1), (Box et al., 2008). This demand will be forecasted using a minimum mean square error (MMSE) forecasting method. The mean centred AR(1) process is given by

$$d_t = \mu + \rho(d_{t-1} - \mu) + \varepsilon_t, \quad (7.9)$$

where  $d_t$  is the demand at time period  $t$ ,  $\rho$  is the first-order auto-regressive parameter, where  $-1 < \rho < 1$  is required for stability and invertibility of the demand process (Box et al., 2008).  $\varepsilon_t$  is a white noise random process with zero mean and a variance of  $\sigma_\varepsilon^2$ . Note that the white noise random process can be drawn from any continuous distribution. We also assume that the mean demand  $\mu$  is zero without altering the variance as we have a linear system. Using MMSE forecasting, the forecasts required by the OUT policy become

$$\begin{aligned}\hat{d}_{t,t+T_p+1} &= \rho^{T_p+1} d_t, \\ dwip_t &= \sum_{i=0}^{T_p} \rho^i d_t = \rho d_t + \rho^2 d_t + \dots + \rho^{T_p} d_t = d_t \rho (1 - \rho^{T_p+1}) / (1 - \rho).\end{aligned}\quad (7.10)$$

The behaviour of the desired work-in-progress multiplier,  $\rho(1 - \rho^{T_p+1}) / (1 - \rho)$ , is rather complex and hints at an odd-even lead time effect that we will see throughout our analysis. When  $\rho > 0$ ,  $\rho(1 - \rho^{T_p+1}) / (1 - \rho)$  is increasing in  $T_p$  and  $\rho$ . When  $\rho < 0$  and the lead time  $T_p$  is even then it is negative but increasing in  $\rho$ , when the lead time is odd, then it is negative and convex in  $\rho$ .

Chapter 11 details how the squared order forecast errors over  $m$  periods for Scenario A can be shown to be

$$\Delta_A = \sigma_\varepsilon^2 \left( \frac{m(1 - 2\rho^{2+T_p})}{(\rho - 1)^2} + \frac{\rho^{4+2T_p} (2m(1 + \rho) + \rho^{2m} - 1)}{(\rho^2 - 1)^2} \right). \quad (7.11)$$

Equation (7.11) is increasing in  $m$ . When  $\rho = 1$ ,  $\Delta_A \rightarrow \infty$ ,  $\Delta_A$  appears to have a single minimum in  $\rho$  and as the derivative of  $\Delta_A$  w.r.t.  $\rho$  is always positive, the minimum must occur in the region  $-1 < \rho < 0$ . Chapter 11 shows that the performance of future guidance proposed in Scenario B is given by

$$\Delta_B = \sigma_\varepsilon^2 \left( \frac{\frac{m\kappa^2}{T_i^2 \left(1 - \left(\frac{T_i-1}{T_i}\right)^2\right)} + \frac{\rho^{2(1+T_p)} \left(m(1-\rho^2) + \rho^2(\rho^{2m}-1)\right)}{(\rho^2-1)^2}}{2\kappa\rho^{1+T_p} \left(m\left(1 - \frac{\rho(T_i-1)}{T_i}\right) + \frac{\rho(T_i-1)}{T_i} \left(\left(\frac{T_i-1}{T_i}\right)^m - 1\right)\right)} + \frac{1}{T_i \left(\frac{\rho(T_i-1)}{T_i} - 1\right)^2} \right), \quad (7.12)$$

where  $\kappa = (1 - \rho^{T_p+1}) / (1 - \rho)$ .

Chapter 11 also shows that the performance of the PFG proposed in Scenario C that accounts for the influence of the proportional controller  $T_i$ , is given by

$$\Delta_C = \sigma_\varepsilon^2 \left( \frac{\frac{\kappa^2 \left(\left(\frac{T_i-1}{T_i}\right)^{2m+2} - \left(\frac{T_i-1}{T_i}\right)^2 (m+1) + m\right)}{\left(\left(\frac{T_i-1}{T_i}\right)^2 - 1\right)^2 T_i^2} + \frac{\left(\rho^2(\rho^{2m}-1) - m\rho^2 + m\right)\rho^{2T_p+2}}{(\rho^2-1)^2}}{2\kappa\rho^{T_p+1} \left(\frac{\rho(T_i-1)}{T_i} \left(\left(\frac{\rho(T_i-1)}{T_i}\right)^m - 1\right) + m - \left(\frac{T_i-1}{T_i}\right)m\rho\right)} + \frac{1}{T_i \left(\left(\frac{T_i-1}{T_i}\right)\rho - 1\right)^2} \right). \quad (7.13)$$

For the i.i.d. demand case at  $\rho = 0$  (7.11), (7.12) and (7.13) reduce to

$$\Delta_A = m \quad (7.14)$$

$$\Delta_B = m / (2T_i - 1) \quad (7.15)$$

and

$$\Delta_C = \frac{\left(\left(\frac{T_i-1}{T_i}\right)^{2m} - 1\right)(T_i - 1)^2 + m(2T_i - 1)}{(1 - 2T_i)^2} \quad (7.16)$$

which can be arranged into descending order of nervousness,  $\Delta_A > \Delta_B > \Delta_C$ , when  $T_i > 1$ .

### 7.3 Analysis of the three scenarios

In this section we will compare the performance of the three scenarios in order to test two conjectures. The first conjecture is whether or not the POUT policy is useful in terms of reducing system nervousness. Second, we test whether or not the PFG in Scenario C is superior to the order forecasts that are based solely on the demand forecasts. To simplify notation, we assume throughout this section that  $\sigma_\varepsilon^2 = 1$ .

#### 7.3.1 Comparison of the nervousness in Scenario A and B

The value of the proportional feedback controller on the accuracy of the information is examined by comparing Scenario A and Scenario B. It can be shown that  $\Delta_A > \Delta_B$  when  $T_i > 1$  and  $\rho \geq 0$ , implying that nervousness is reduced by the POUT policy.

Figure 7.1 illustrates the influence of feedback controller  $T_i$  when the lead time of  $T_p = 3$  and the forecast horizon  $m = 3$ . The solid line gives the sum squared order error  $\Delta$  for each value of  $\rho$  in Scenario A. The dashed lines represent the accuracy of Scenario B when different values of the feedback controller are adopted. If demand is positively correlated, the feedback controller  $T_i > 1$ , is able to significantly reduce nervousness (see Figure 7.1). More accurate order forecasts can usually be obtained with a larger  $T_i$ . For negatively correlated demands, Scenario A may sometimes be less nervous than Scenario B (Figure 7.2a). Recall, Scenario B degenerates in Scenario A when  $T_i = 1$ .

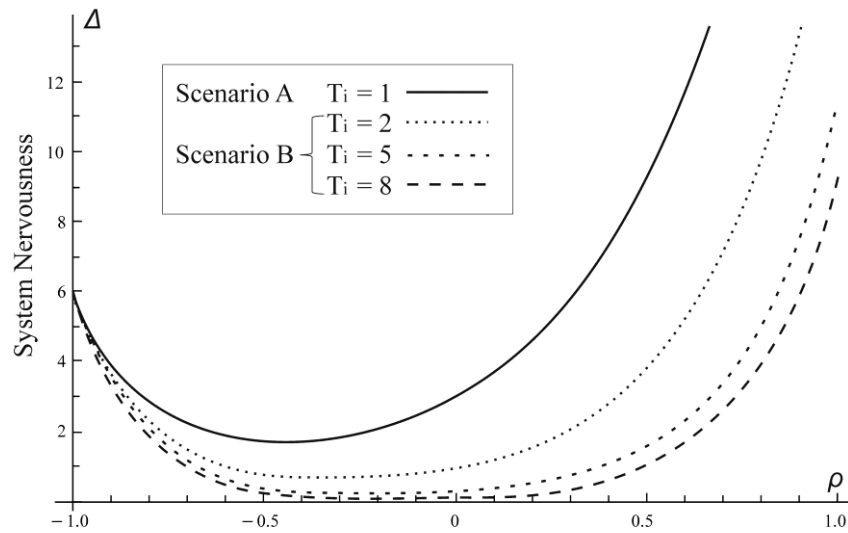

Figure 7.1 Influence of  $T_i$  when  $T_p = 1$ ,  $m = 3$

The lead time  $T_p$  has a rather complex impact on system nervousness, see Figure 7.2. When demands are highly negatively correlated, there is an odd-even lead time effect (Figure 7.2a and Figure 7.2b) in both Scenario A and B. For Scenario A especially, the nervousness can be reduced if the lead time is changed from an odd number to an even number, and will increase if the lead time changes from an even number to an odd number. This odd-even lead time effect only happens when  $\rho < 0$  and the lead time is short. When  $\rho$  is near 0, the effect of the lead time is rather small (see Figure 7.2c and Figure 7.2d) as the order forecasts are an exponential function of  $\rho$  and  $T_p$ . When  $\rho \gg 0$ , the impact of the lead time is much more significant for Scenario A than for Scenario B, see Figure 7.2e. It is also clear that the future guidance in Scenario B is less sensitive to lead times than in Scenario A.

When  $T_i > 1$  and the lead time  $T_p$  is an odd number,  $\Delta_A > \Delta_B$  for any  $\rho$ . This is another sufficient condition for  $\Delta_A > \Delta_B$ . As the supply lead-time in practice is often a result of contract negotiation, by appropriate selection of lead times in a supply chain the retailer’s POUT system is always able to reduce the nervousness in the manufacturer’s MRP system.

In summary, the POUT policy is able to forecast future orders more accurately than the OUT policy, even with correlated demand and lead-times. Usually, increasing  $T_i$  reduces system nervousness, although the demand process and the lead-time do have an impact on the benefits of  $T_i$ . The accuracy of Scenario B is less sensitive to the lead time  $T_p$  and the forecast horizon  $m$ , than Scenario A.

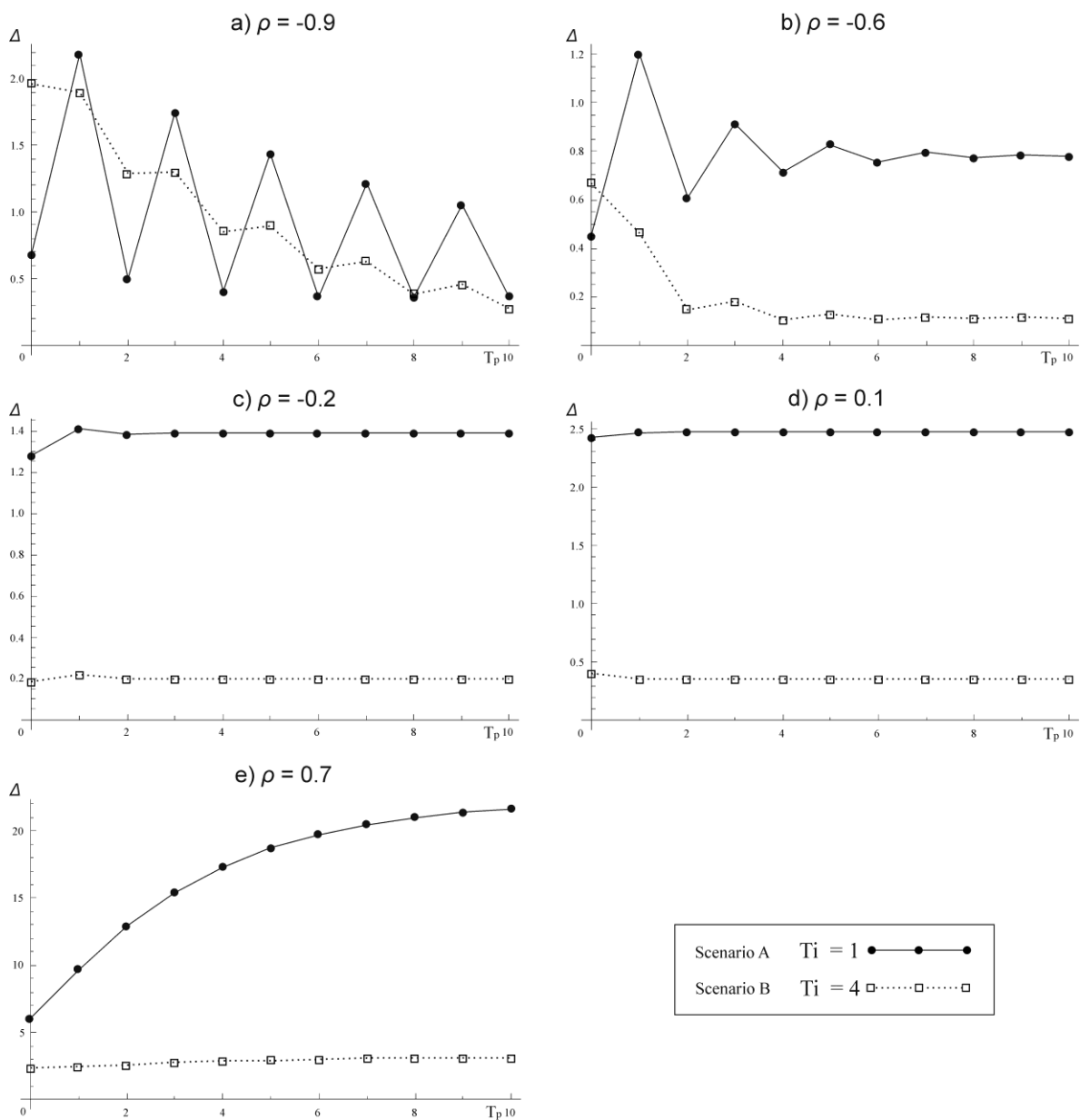

Figure 7.2 Impact of lead time when  $m = 2$

### 7.3.2 Comparison of the nervousness in Scenario B and C

If demand is independent and identically distributed (i.i.d.) the variance of  $\delta_t$  for  $j$ -period ahead order forecast errors,  $\Delta[j]$ , in Scenario B is given by

$$\Delta_B[j] = \sum_{n=0}^{\infty} \left( \frac{1}{T_i} \left( \frac{T_i-1}{T_i} \right)^n \right)^2 = (2T_i - 1)^{-1} \quad (7.17)$$

which is decreasing in  $T_i$  and independent of  $j$  and  $T_p$ . The nervousness of the  $m$  period order forecast (7.15) is increasing in  $m$ , and decreasing in  $T_i$ .

Scenario C has the same call-off order quantity as Scenario B and hence creates the same amount of bullwhip / smoothing. However, Scenario B only uses the demand forecasts to create the future order forecasts, whereas Scenario C uses the PFG to produce the order forecasts. For i.i.d. demand the variance of the  $j$  period ahead order forecast error can be obtained by setting  $\rho = 0$  in (11.17),

$$\Delta_C[j] = \sum_{n=0}^{j-1} \left( \frac{1}{T_i} \left( \frac{T_i-1}{T_i} \right)^n \right)^2 = \left( 1 - \left( \frac{T_i-1}{T_i} \right)^{2j} \right) / (2T_i - 1) \quad (7.18)$$

As  $j \rightarrow \infty$ , (7.18) converges to  $(2T_i - 1)^{-1}$ . The nervousness in the  $m$  periods order forecast (7.16) is increasing in  $m$  and independent of the lead time  $T_p$ .

The variance of the  $j$  period ahead order forecast error in both Scenario B and C is shown in Figure 7.3. Although the accuracy of the proportional method declines over time, the reduced nervousness in the near future is obvious. This will be of more practical benefit than an equivalent reduction of nervousness in the distant future.

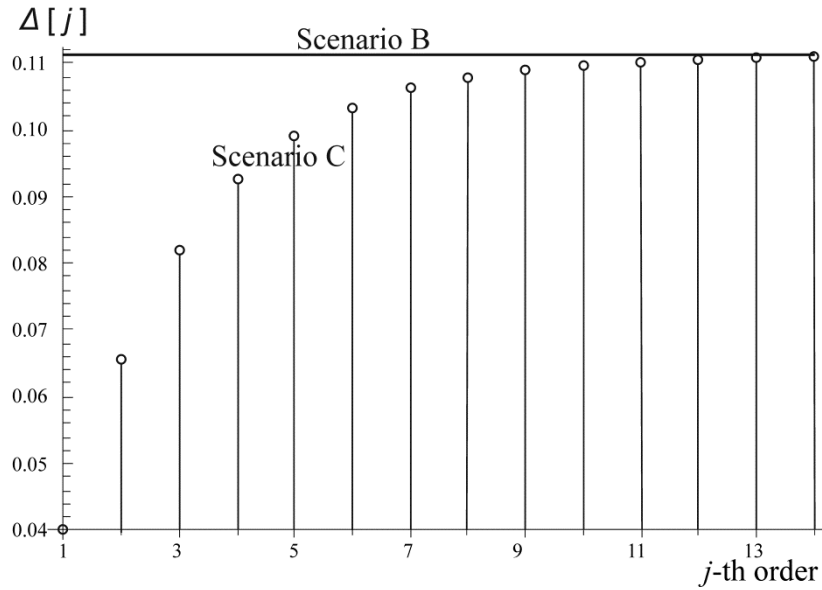

Figure 7.3 Accuracy of different forecasted orders for i.i.d. demand when  $T_i = 5$

When AR(1) demand is present, the difference in nervousness between Scenario B and Scenario C is given by

$$\Delta_B - \Delta_C = \frac{\left(1 - \left(\frac{T_i - 1}{T_i}\right)^{2m}\right) (T_i - 1)^2 (\rho^{1+T_p} - 1)^2}{(1 - 2T_i)^2 (\rho - 1)^2}. \tag{7.19}$$

Equation (7.19) is always positive when  $T_i \in (0.5, 1) \cup (1, \infty)$ ,  $T_p \in \mathbb{N}^0$  and  $|\rho| < 1$ . This means that Scenario C is less nervous than Scenario B.

A ratio  $\left(\frac{\Delta_B - \Delta_C}{\Delta_B}\right) \times 100\%$  can be used to further explore the scale of the improvements in accuracy by moving from Scenario B to Scenario C. Figure 7.4 illustrates the density plots of the percentage of accuracy improvements for different  $\rho$ ,  $T_i$  and  $m$ . The x-axis is the demand correlation. The y-axis uses the scale of  $1/T_i$  to plot all possible stable settings of the feedback controller  $T_i$  (from 0.5 to  $\infty$ ). It is easy to notice that improvements can be achieved by extending  $T_i$  to near the edge of its stability interval  $(0.5, \infty)$ . Larger forecast horizons lead to larger measures of nervousness.



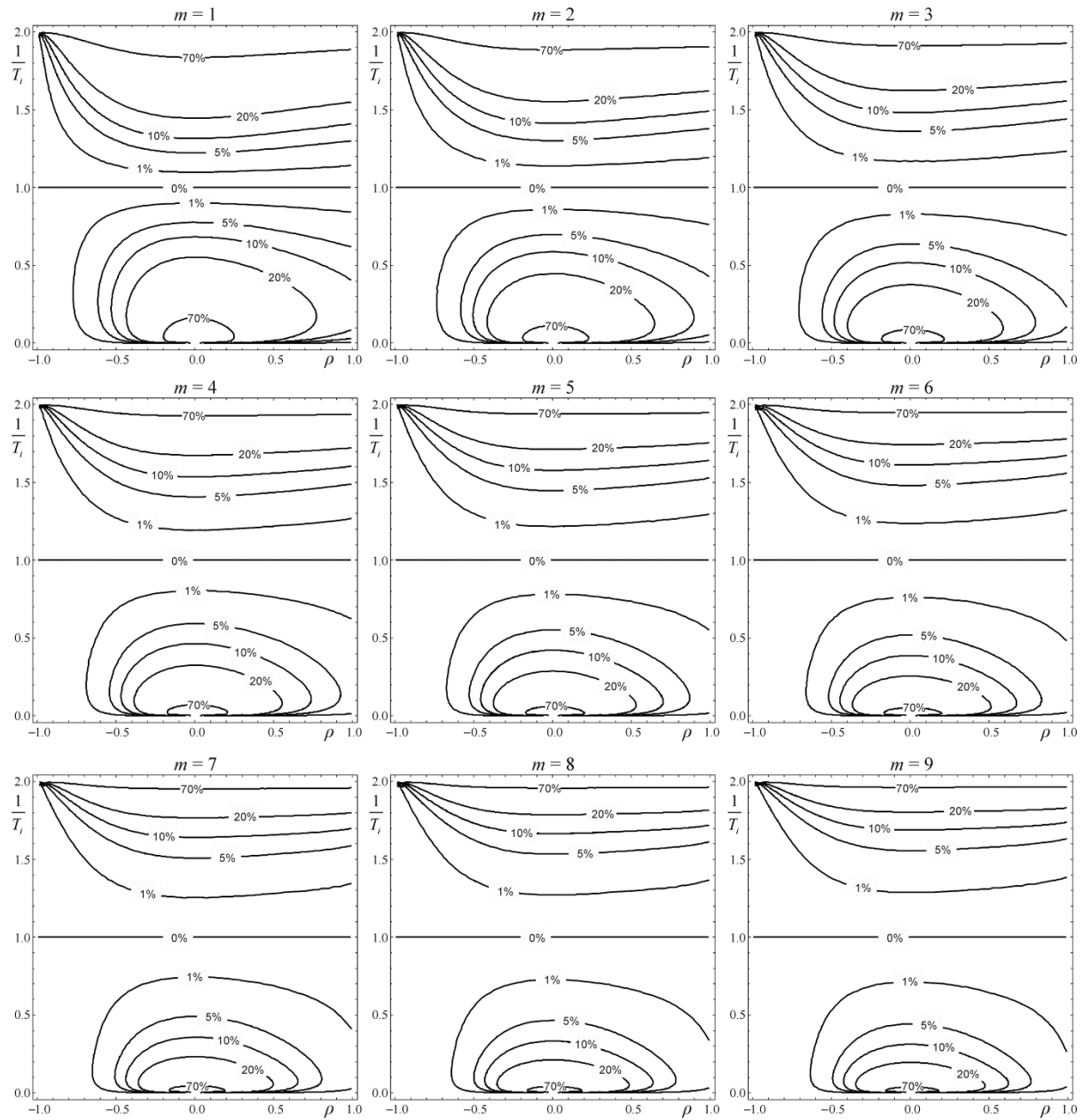

Figure 7.4 Percentage improvements when  $T_p = 1$

Figure 7.5 demonstrates how changes of feedback controller and the lead time will affect the accuracy of the PFG in Scenario C. Nervousness over  $m$  periods decreases in  $T_i$  (Figure 7.5a). However, depending on the demand correlation, the lead time  $T_p$  can also have a strong influence (Figure 7.5b). Accuracy improvements can be obtained by setting a higher value of  $T_i$  for positively correlated demand, but an increase in the feedback controller value will

reduce the accuracy of the future guidance when demands are negatively correlated. As with the odd-even lead time effect explored earlier in the comparison of Scenario A and B, an odd lead time is preferable as it allows for more accurate PFG in Scenario C.

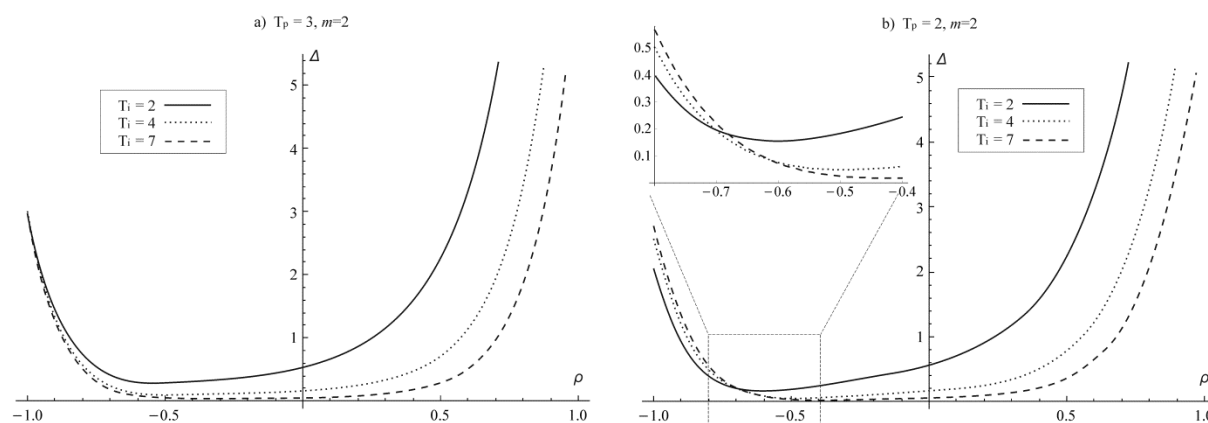

Figure 7.5 Odd-even lead time effect on the impact of  $T_i$  in Scenario C

Analytical results have shown that the PFG proposed in Scenario C is able to produce more accurate predictions of the retailers future order quantity than the POUT order call-offs with the MMSE order forecasts. As the feedback controller can eliminate the bullwhip effect (Disney et al., 2004) and reduce nervousness, this is a valuable tool for coordinating supply chains. When the retailer adopts the POUT system to manage his inventory and uses the PFG he will create less bullwhip, and a less nervous MRP system in the supplier.

### 7.3.3 Inventory and bullwhip performance in the supply chain

If the order forecasts are of low quality, the retailer and the manufacturer may decide to act uncooperatively. A manufacturer that has inaccurate future guidance from the retailer will be less willing to work to forecasted orders, often leading to poor service. The retailer will then penalise the manufacturer that has not been able to meet the service target. Together, they create a “tit-for-tat” situation as discussed in Terwiesch et al. (2005). We have ascertained

that the POUT policy and the PFG combination is able to produce more accurate order forecasts. We now also consider that the retailer shares order forecasts truthfully, and the manufacturer trusts the forecasts. This section will further analyse the inventory and bullwhip performance in this two-tier supply chain. The variance of the net stock level at the manufacturer is important as it produces inventory holding and backlog costs and it has an immediate effect on customer service metrics such as availability and fill rates.

The retailer generates the call-off orders  $o_{t,1}$  and the future guidance via the proportional method from (7.5) in Scenario C. After the manufacturer has received the information from the retailer, the manufacturer then incorporates this into his OUT system by setting,

$$\begin{aligned} o_{t,2} &= s_{t,2} - s_{t-1,2} + d_{t,2} \\ &= \left( \hat{o}_{t,t+T_s+1} + \sum_{j=1}^{T_s} \hat{o}_{t,t+j} \right) - \left( \hat{o}_{t-1,t+T_s} + \sum_{j=1}^{T_s} \hat{o}_{t-1,t-1+j} \right) + o_t, \end{aligned} \quad (7.20)$$

where  $o_{t,2}$  is the production ordering decision made by the manufacturer at time  $t$ ; the demand that the manufacturer received at time  $t$ ,  $d_{t,2}$ , is the official order quantity from the retailer,  $d_{t,2} = o_t$ ; the forecasts for the demand during and in the period after the manufacturer's lead time  $T_s$  are drawn from the retailer's future guidance. The net stock at the manufacturer,  $ns_{t,2}$ , is governed by the following balance equation

$$ns_{t,2} = ns_{t-1,2} + o_{t-T_s-1,2} - o_t. \quad (7.21)$$

### 7.3.3.1 Inventory performance in three scenarios

The variance of the retailer's inventory under the POUT policy is given by

$$\sigma_{ns_1}^2 = \frac{\sigma_\varepsilon^2}{(1-\rho)^2} \left( \frac{(T_p+1)(1-\rho^2) + \rho(1-\rho^{T_p+1})(\rho^{T_p+2} - \rho - 2)}{(1-\rho^2)} + \frac{\left(\frac{T_i-1}{T_i}\right)^2 (\rho^{T_p+1} - 1)^2}{1 - \left(\frac{T_i-1}{T_i}\right)^2} \right), (7.22)$$

Hosoda and Disney (2006), which has a minimum at  $T_i = 1$  and is increasing in  $T_p$  (recall  $T_p \in \mathbb{N}_0$ ). By setting the feedback controller  $T_i = 1$  in (7.22), the function represents the net stock variance of the OUT policy in Scenario A.

The manufacturer's inventory variance for Scenario C is (for details see Chapter 12)

$$\begin{aligned} \sigma_{ns_2,C}^2 &= \sigma_\varepsilon^2 \sum_{n=0}^{T_s} \left( \sum_{i=0}^n \left( \rho^{T_p+1+i} + \frac{(1-\rho^{T_p+1})\left(\frac{T_i-1}{T_i}\right)^i}{T_i(1-\rho)} \right) \right)^2 \\ &= \frac{\sigma_\varepsilon^2}{(1-\rho)^2} \sum_{n=0}^{T_s} \left( \left(\frac{T_i-1}{T_i}\right)^{1+n} (\rho^{1+T_p} - 1) + 1 - \rho^{2+n+T_p} \right)^2. \end{aligned} (7.23)$$

When  $\rho$  is close to zero and  $T_i \rightarrow \infty$ , (7.23) approaches zero. This means that the manufacturer's inventory level will exhibit less variance than the white noise process driving the whole system. In other words, it is possible to achieve a (near) zero inventory policy without making the customer wait for the production with this coordination scheme, see Figure 7.6. This is a performance that even the retailer could not achieve. There is a fundamental trade-off to be made between the retailer's inventory, the manufacturer's inventory and nervousness. The retailer experiences higher inventory variance than the manufacturer. The manufacturer's net stock variance can be reduced by setting  $T_i > 1$  which is the same condition of reducing nervousness. But this setting will result in a higher net stock variance at the retailer.

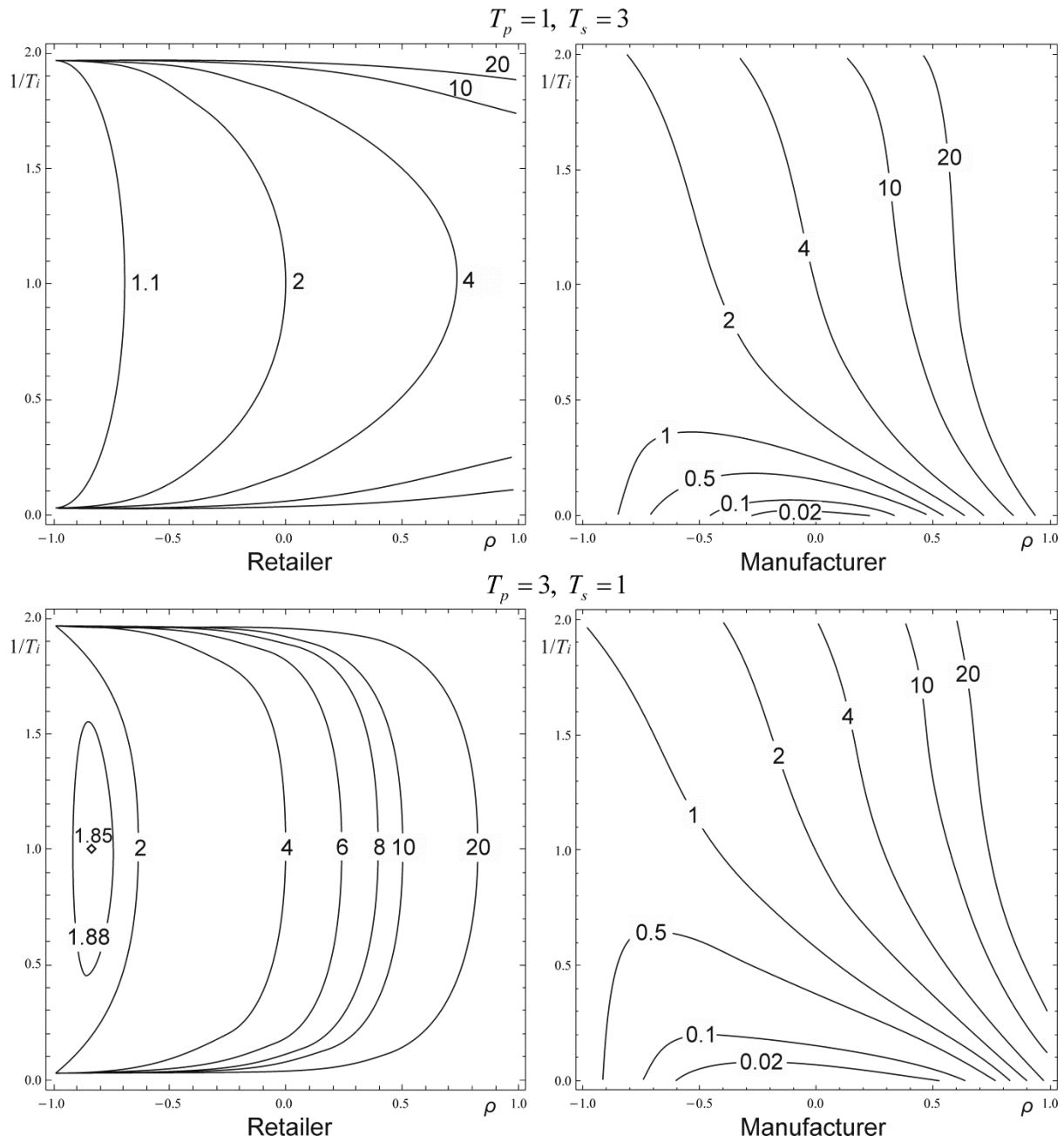

Figure 7.6 Net stock variance in a two-echelon supply chain

In terms of the manufacturer's net stock variance for Scenario A and B, they are:

$$\sigma_{ns_2,A}^2 = \frac{\sigma_\varepsilon^2}{(1-\rho)^2} \left( T_s + \frac{2\rho^{3+T_p+T_s}}{1-\rho} + \frac{1-\rho^2 \left( 1 + \rho^{T_p} (2 + 2\rho - \rho^{2+T_p} + \rho^{2(2+T_s)+T_p}) \right)}{(1-\rho)(1+\rho)} \right) \quad (7.24)$$

and

$$\sigma_{ns_2,B}^2 = \sigma_\varepsilon^2 \left( \sum_{n=0}^{T_s} \left( \sum_{i=0}^n \left( \rho^{T_p+1+i} + \frac{\kappa}{T_i} \left( \frac{T_i-1}{T_i} \right)^i \right) \right)^2 + \sum_{n=0}^{\infty} \left( \left( \frac{T_i-1}{T_i} \right)^{1+n} \left( 1 - \left( \frac{T_i-1}{T_i} \right)^{T_s+1} \right) \kappa \right)^2 \right). \quad (7.25)$$

It can be seen that  $\sigma_{ns_2,C}^2 < \sigma_{ns_2,B}^2$ . From section 7.3.1 and 7.3.2, an odd  $T_p$  is recommended to avoid the odd-even lead-time effect on the nervousness in both Scenario B and C. Based on that, if we assume  $T_p$  is an odd number,  $\sigma_{ns_2,C}^2 < \sigma_{ns_2,B}^2 < \sigma_{ns_2,A}^2$  always holds for any  $\rho$  value when  $T_i > 1$ . Larger  $\rho$  value leads to larger reductions in the manufacturer's net stock variance from the use of the POUT policy and PFG strategy at the retailer.

### 7.3.3.2 Bullwhip in three scenarios

The order variance generated by the retailer in Scenario B or C is:

$$\sigma_{o_1}^2 = \frac{\sigma_\varepsilon^2}{(1-\rho)^2} \left( \frac{2 \left( \frac{T_i-1}{T_i} - \rho \right) \left( \left( \frac{T_i-1}{T_i} - \rho \right) \rho^{T_p+1} + \frac{1+\rho}{T_i} \rho^{T_p+1} + \frac{1+\rho}{T_i} \left( 1 - \rho \left( \frac{T_i-1}{T_i} \right) \right) \right)}{\left( \frac{1+\rho}{T_i} \right) \left( 1 - \rho \left( \frac{T_i-1}{T_i} \right) \right)} \right) \quad (7.26)$$

which is equivalent to the order variance function in Hosoda and Disney (2006). The retailer's order variance in Scenario A can be obtained as a special case of (7.26) with  $T_i = 1$ .

For  $\rho = 0$ , the lead time  $T_p$  has no impact on the order variance as  $\sigma_o^2 = \sigma_d^2 / (2T_i - 1)$ , reminder the demand variance of AR(1) is given by

$$\sigma_d^2 = \frac{\sigma_\varepsilon^2}{1-\rho^2} \quad (7.27)$$

Here, order variance is: decreasing in  $T_i$ ; zero when  $T_i = \infty$ ; equal to demand when  $T_i = 1$  and approaches infinity when  $T_i \rightarrow 0.5$  from above.  $T_i > 1$  always reduces the bullwhip

effect for  $\rho = 0$ . We refer readers to Disney et al. (2004) for the detailed bullwhip behaviour of the POUT system, MMSE forecasting, and i.i.d. demand.

For  $0 < \rho < 1$ , by setting  $T_i^{-1} < 1 - \rho$ , it is always possible to avoid generating the bullwhip effect for any lead-time  $T_p$  (proofs are given in Chapter 13). If  $0 < T_i^{-1} < 2$ , the order variance is: decreasing in  $T_i$ ; equal to demand variance when  $T_i^{-1} = 1 - \rho$ . It is interesting that for positive  $\rho$ , (7.26) is a decreasing function of  $T_p$  when  $T_i^{-1} < 1 - \rho$ , and an increasing function of  $T_p$  when  $T_i^{-1} > 1 - \rho$ .

For negative  $\rho$ ,  $T_p$  has an odd-even lead-time effect on the retailer's order variance. When  $T_p$  increases, the order variance will oscillate and eventually converge at  $\sigma_{o_1}^2 \Big|_{T_p \rightarrow \infty} = \sigma_\varepsilon^2 / ((2T_i - 1)(1 - \rho)^2)$ . If  $T_i > 1$ , it is possible to eliminate the bullwhip effect by setting a large  $T_i$  or  $T_p$ . If  $T_i = 1$ , the OUT policy is present and  $\sigma_{o_1}^2 > \sigma_d^2$  must exist. If  $0.5 < T_i < 1$ , there are a few occasions that the bullwhip effect can be avoided, but in general this is not a setting that is universally recommended.

The order variance at the manufacturer in Scenario C is

$$\sigma_{o_2}^2 = \frac{\sigma_\varepsilon^2}{(1 - \rho)^2} \left( \begin{array}{l} 1 + \frac{2\rho^{2(3+T_p+T_s)}}{1 + \rho} + \frac{2\left(\frac{T_i-1}{T_i}\right)^{2T_s} (1-T_i)^4 (1-\rho^{1+T_p})^2}{T_i^3 (2T_i - 1)} \\ \frac{2\left(\frac{T_i-1}{T_i}\right)^{T_s} (1-T_i)^2 (1-\rho^{1+T_p})}{T_i^2} \\ 2 \left( 1 - \frac{\left(\frac{T_i-1}{T_i}\right)^{T_s} (1-T_i)^2 (1-\rho^{1+T_p}) (1+T_i(1-\rho))}{T_i^2 (\rho + T_i(1-\rho))} \right) \rho^{3+T_p+T_s} \end{array} \right). \quad (7.28)$$

By tuning the  $T_i$  value, it is possible to reduce the manufacturer's order variance to be no greater than the variance of consumer demand for any lead-times for any demand patterns. More bullwhip reduction can be achieved by setting a large  $T_i$  value. But when the manufacturer's lead-time  $T_s$  is significantly large, the manufacturer's order variance is not determined by any other factors except for the consumer demand patterns. A detailed discussion of the behaviour of the manufacturer's order variance in Scenario C can be found in Chapter 14. In summary, the POUT policy with PFG strategy is able to eliminate the bullwhip, reduce nervousness and requires less inventory in the supply chain.

If the manufacturer applies the information from the order stream in Scenario B, his order variance would be

$$\sigma_{o_2,B}^2 = \sigma_\varepsilon^2 \frac{\left( \begin{aligned} &2T_i(2T_i - 1)(T_i(1 - \rho) + \rho)\rho^{2(3+T_p+T_s)} - \\ &2(2T_i - 1)(1 + \rho)(1 + (T_i - 1)(1 + T_i(1 - \rho)))\rho^{1+T_p}\rho^{3+T_p+T_s} + \\ &(T_i(1 - \rho) + \rho)(1 + \rho)(T_i + 2(T_i - 1)\rho^{1+T_p} + 2(T_i - 1)^2\rho^{2+2T_p}) \end{aligned} \right)}{(1 - \rho)^2 T_i(2T_i - 1)(T_i(1 - \rho) + \rho)(1 + \rho)} \quad (7.29)$$

When  $\rho = 0$ , the effect of the lead-times disappears as (7.29) reduces to  $\sigma_{o_2,B}^2 = \sigma_\varepsilon^2 / (2T_i - 1)$ , which is the same as the retailer's order variance, for any  $T_i$  value. When  $\rho < 0$ , both  $T_p$  and  $T_s$  have odd-even lead-time effects on the manufacturer's order variance. When  $\rho > 0$ , the behaviour of (7.29) is complex.

In Scenario A, the order variance can be obtained by assigning  $T_i = 1$  in (7.29),

$$\sigma_{o_2,A}^2 = \frac{\sigma_\varepsilon^2}{(1 - \rho)^2} \left( \frac{1 + \rho + 2\rho^{2(3+T_p+T_s)} - 2\rho^{3+T_p+T_s}(1 + \rho)}{1 + \rho} \right) \quad (7.30)$$



which has a limit of  $\sigma_d^2$  when  $T_p$  and  $T_s$  approach to positive infinity. (7.30) always equals to  $\sigma_d^2$  for any lead-times when  $\rho=0$ ; is increasing in  $T_p$  and  $T_s$  but less than  $\sigma_d^2$  when  $\rho>0$ ; oscillates around  $\sigma_d^2$  when  $\rho<0$  because  $T_p$  and  $T_s$  produce an odd-even lead-time effect. However, the order variance at the manufacturer in Scenario A is always larger than in Scenario B and C when  $T_i > 1$ .

The POUT policy and the PFG mechanism have both shown to be very useful for eliminating bullwhip, reducing system nervousness and reducing inventory variance at the manufacturer. By tuning the  $T_i$  value, it is always possible to avoid generating the bullwhip effect at both echelons for any demand correlation and for all lead-times. Although the trade-off between the bullwhip and inventory variance at the retailer has been acknowledged by the literature, we show for the first time that the nervousness, the inventory variance at the manufacturer, and the order variance at both the retailer and the manufacturer, are all decreasing in  $T_i$  when  $T_i > 1$  and  $T_p$  is odd.

## 7.4 Summary

Issuing call-off orders and order forecasts to suppliers is common in industries, however, it normally create a stressful circumstance with both bullwhip effect and system nervousness. The author believes this is one of the first study to consider the bullwhip effect and system nervousness simultaneously. Three different methodologies have been applied to generate the set of call-off orders and order forecasts. We have shown that odd-even lead time effects exist in the system nervousness, the order variance and the inventory variance.

The POUT policy is effective of reducing the difference between the predicted orders and the call-off orders in the majority of the cases when the demand is an AR(1) process. As the feedback controller is able to reduce bullwhip, it is an intuitive and attractive choice for practical use.

We analysed a new proportional method to produce more accurate order forecasts. Because of the improvements in the accuracy of the information, downstream players in a supply chain are able to reduce system nervousness in the upstream players and allow them to achieve better inventory performance and capacity utilisation. The PFG method is easy to understand and since it does not require the sophisticated integrated IT systems that the POS sharing strategy does, it should be easy to implement. Moreover, it does not need the retailer to disclose any information on end-customer demand and their inventory policies, because the orders and order forecasts information and the benefits are produced by the retailer.

Both players in the supply chain can benefit by using the POUT policy with PFG. The downstream player will be able to maintain good control of capacity costs in their own organisation and promote reduced capacity and inventory costs upstream. By using the PFG, the retailer will also be able to reduce the nervousness in the manufacturer's MRP system. Our analysis confirms that this PFG can significantly reduce the manufacturer's inventory cost. However, this will come at a higher cost for the downstream of increased inventory.

Among the net stock amplification, the bullwhip effect, and the nervousness, only the first performance measure is of a profit-maximising retailer's concern. The increased inventory costs might not satisfy their interests, as it is directly related to the profits, even if it is a slight increase. The sacrifice from the retailer, on the other hand, generates much more cost savings at the manufacturer site. Under this circumstance, the retailer normally needs incentives to help the supply chain. Both parties could set a preliminary agreement clarifying the profit

sharing mechanism, and fulfil the agreement afterwards. Another option often appears in practice is that the retailer could negotiate a better contract with lower purchase price from the manufacturer based on the possible savings they can bring to the manufacturer. If a manufacturer's saving can be reallocated to downstream players like retailers; then there would still be an incentive to coordinate the supply chain (Disney et al. 2008).

## 8. Conclusions

This chapter will relate the findings back to the research questions outlined in the first chapter. Additionally, implications and limitations of this thesis will be summarised, and potential areas for further investigation will be outlined.

### 8.1 Discussion of the primary research question

*Q1: Is Damped Trend forecasting superior to other methods from supply chain dynamics perspective?*

Since the Damped Trend forecasting method was developed by Gardner and McKenzie (1985), its great potential has been discussed in the literature (Gardner, 1985; Gardner and McKenzie, 1988, 1989; Makridakis and Hibon, 2000; Snyder, Koehler and Ord, 2002; Taylor, 2003; Armstrong, 2006; Gardner 2006; Fildes et al., 2008; Snyder and Koehler, 2009; McKenzie and Gardner, 2010; Gardner and McKenzie, 2011; Acar and Gardner, 2012; Lin et al., 2013; Sbrana and Silvestrini, 2014). However, this thesis is the first to study the Damped Trend forecasting method in a supply chain context. The answer is yes, it is superior to other forecasting methods. In order to provide a more detailed answer to the research question Q1, a discussion of the sub-questions will now be presented:

*a) What are the stability conditions of Damped Trend method from control theory perspective?*

In Gardner and McKenzie's (1985) paper, they characterised the stability region of Damped Trend forecasting as

$$\begin{cases} (\phi-1)/\phi < \alpha < (\phi+1)/\phi \\ \phi\alpha\beta + (1-\phi)\alpha > 0 \\ \phi\alpha\beta + (1+\phi)\alpha < 2(1+\phi) \end{cases} \quad (8.1)$$

It is easy to notice that the first condition in (8.1) is true only when  $\phi > 0$ . They also stated in the beginning of their theoretical development that the DT generalisation includes four possibilities of trend depending on the value of  $\phi$ , and they are  $\phi = 0$ ,  $0 < \phi < 1$ ,  $\phi = 1$  and  $\phi > 1$ . Apparently, the stability areas with a negative  $\phi$  were not considered.

However, from control theory perspective, this thesis has proved that the DT method is stable over a broader range of parameter settings, including the region when  $\phi < 0$ . The negative  $\phi$  region is important because there are some desirable system performances in this area. In addition, the thesis has demonstrated that the invertibility regions and stability regions for DT forecasting are identical, indicating that any stable DT settings produce feasible forecasts. Therefore it is worth studying the system performance over the whole stability region.

*b) How do we integrate Damped Trend forecasts into the Order-Up-To policy?*

The OUT policy needs two types of forecasts – the forecast for the demand after the lead-time  $\hat{d}_{t,t+T_p+1}$  and the forecasts for the demand during the lead-time  $\sum_{i=1}^{T_p} \hat{d}_{t,t+i}$  (also called desired work-in-progress). Traditionally, it is suggested that the forecast  $\hat{d}_{t,t+T_p+1} = \hat{d}_{t,t+1}$ , and desired work-in-progress is set to  $T_p \hat{d}_{t,t+1}$ . As the Damped Trend is able to produce individual, n-period ahead forecasts, with improved accuracy, these forecasts were treated individually and explicitly in the thesis. We used transfer function as an analytical modelling tool and showed how the transfer function of the forecasting mechanisms can be incorporated into a transfer function model of the OUT policy. They are simple to understand and easy to use no matter which particular forecasting method is used.

c) *How do we measure the bullwhip effect and net stock amplification for non-stationary demand processes?*

This thesis has derived a new criterion of the bullwhip effect for non-stationary demand series. This is because the DT method is also able to forecast time series with linear or exponential trends. By analysing the differences between  $\sigma_o^2$  and  $\sigma_d^2$  (Gaalman and Disney, 2012), this thesis found that if  $\left| \frac{O(e^{j\omega})}{\varepsilon(e^{j\omega})} \right| > 1 \forall \omega$  then a bullwhip effect always exists regardless of  $\left| \frac{D(e^{j\omega})}{\varepsilon(e^{j\omega})} \right|$ . This is a sufficient condition for bullwhip for any demand series. Then the modulus of the order rate transfer function was linked to Amplitude Ratio (AR),  $\left( \left| \frac{O(e^{j\omega})}{\varepsilon(e^{j\omega})} \right| = AR \right)$ . If  $AR < 1$  holds only for a certain range of harmonic frequencies, it is possible to reduce the order variance to less than the demand variance for a certain demand pattern, therefore eliminating the bullwhip effect. The same method can be applied to analyse the net stock amplification after replacing  $O(e^{j\omega})$  with  $NS(e^{j\omega})$ . By investigating the Amplitude Ratio frequency response plots, it is able to gain insights into how the forecasting and the replenishment system creates or avoids bullwhip or net stock amplification for arbitrary demand patterns.

d) *What are the consequences of using DT forecasts on the bullwhip and net stock amplification?*

This thesis proved that some special cases of DT forecasting (Naïve, SES and Holts) when using in the OUT policy will always generate bullwhip for any demand pattern and all lead-times. This is the new and complete proof to the conjecture of Dejonckheere et al. (2003). It is also shown that when the parameters are selected from the conventional suggestions

( $0 \leq \phi \leq 1$ ,  $\alpha > 0$  and  $\beta > 0$ ) the Damped Trend forecasting with the OUT policy will always produce bullwhip for all demand patterns and all lead-times.

The DT / OUT policy cannot avoid amplifying individual harmonics for the whole range of the frequency spectrum. However, it is possible to avoid creating bullwhip for certain demand patterns. There are sophisticated odd-even lead-time effects in the bullwhip avoidance behaviour, but the bullwhip generating and avoidance area for low and high-frequency harmonics have been explicitly explored in the complete stability region.

The thesis also revealed the superb performance of DT forecasts when used in the OUT policy. For some parameter settings, the DT / OUT policy acts like a low-pass filter and is able to avoid the bullwhip effect for certain demand patterns. Similar bullwhip avoidance behaviour has been observed in Dejonckheere et al. (2003), but our results suggest that the DT method could help the OUT policy eliminate the bullwhip effect without the difficult and expensive proportional feedback controller modification to the OUT policy.

More importantly, from the same bullwhip avoidance parametric region, it is possible that the DT / OUT policy acts like a low-pass filter for inventory variance. In other words, the DT / OUT system is able to both avoid the bullwhip effect and maintain good control over the inventory levels simultaneously when the parameter values are selected from this area. The behaviour is by far the best performance compared with other well-known forecasting methods when used in the OUT policy.

Simulation results have verified the analytical findings. 62 real-life demand patterns were used and three objective functions were considered. The three objective functions were relevant when there are only inventory, only capacity, or both inventory and capacity costs present. The DT / OUT system was able to avoid bullwhip in 35, 62, and 52 of the 62 cases

respectively. The distribution of the parameter values when the objective is to minimise both inventory and capacity costs is consistent with the analytical results.

If we look back to the first research question, this thesis is the first to demonstrate that the Damped Trend forecasting method is able to produce better bullwhip and inventory performance compared to other forecasting methods from supply chain dynamics perspective. Whilst the OUT policy, Naïve, SES and Holts method are all available native in many commercial software packages, Damped Trend is less common, and those that we know of, do not allow for negative parameter values. However, we believe that Damped Trend forecasting methodology deserves much more attention as a supply chain forecasting method in the literature than it currently receives.

## **8.2 Discussion of the second research question**

*Q2: How can the system nervousness and the bullwhip in the supply chain be simultaneously reduced, without the disclosure of end consumer demand information?*

The co-existence of the system nervousness and the bullwhip effect is common in many supply chains, but there is currently no research that considers such a situation. In order to answer this research question, three scenarios were setup. In Scenario A, a single retailer uses MMSE demand forecasts within the Order-Up-To policy to generate call-off orders, and the MMSE forecasts are shared with a manufacturer as the order forecasts. In Scenario B, the retailer uses MMSE demand forecasts within the POUT policy, and the order forecasts are treated exactly the same as in Scenario A. In Scenario C, the retailer also adopts the POUT policy, but he applies a new method to produce the order forecasts. In all scenarios, the



retailer faces an auto-regressive random demand of first order, AR(1). By answering the next three sub-questions, the answer to Q2 can be drawn. In broad term – yes it can – the POUT performs well in this aspect and the combination of the POUT and the PFG performs even better.

a) *How should we forecast orders?*

The demand upstream players' receive are orders from downstream players, and these are not the same as the end consumer demand because of inventory management policies and other demand signal processing activities. Therefore, orders usually have more volatility than consumer demand, making it more difficult to forecast. Traditional suggestions either advocate that order forecasts are the same as the demand forecasts, or predict orders based on the long term equilibrium between the demand and the orders. Both these approaches have their own drawbacks. Unfortunately, the importance of producing more accurate order forecasts is understated in the literature. The less accurate order forecasts cause the manufacturers to change their master production plan frequently, leading to more nervous MRP systems. This thesis returned to the essence of the nervousness by studying a method that is able to create more accurate order forecasts.

This thesis quantified the accuracy of order forecasts as the measure of nervousness. It has emphasised that if the Proportional Order-Up-To policy

$$o_t = \hat{d}_{t,t+T_p+1} + \frac{1}{T_i} \left( tns - ns_t + \sum_{i=1}^{T_p} (\hat{d}_{t,t+i} - o_{t-i}) \right) \quad (8.2)$$

can reduce the bullwhip effect in the supply chain, and even more accurate order forecasts can be produced by considering the future consequences of the POUT policy

$$\hat{o}_{t,t+j} = \hat{d}_{t,t+T_p+1+j} + \frac{1}{T_i} \left( \frac{T_i-1}{T_i} \right)^j \left( tns - ns_t + \sum_{i=1}^{T_p} (\hat{d}_{t,t+i} - o_{t-i}) \right), \quad T_i \neq 1, \quad (8.3)$$

which leads to less nervousness in MRP systems. The nervousness created by the POUT and the PFG is the least in all three of our considered scenarios.

Moreover, this method is intuitive, easy to understand, and simple to use. The task can be achieved by the downstream player alone without the difficulties of sharing consumer demand information or inventory policies.

*b) Is the proportional controller able to reduce the nervousness of the system?*

The comparison of Scenario A and Scenario B has indicated that when the demand correlation  $\rho$  is non-negative, the controller  $T_i$  is able to reduce system nervousness. More reduction can be achieved by a larger  $T_i$  value or when demand is highly positively correlated over time. When  $\rho$  is negative, sometimes  $T_i$  creates more nervousness, but this can be avoided by setting the lead time  $T_p$  to an odd number or increasing  $T_i$  further. This brings an opportunity in the supply chain design phase to reduce the nervousness by choosing an appropriate lead-time. Additionally, the performance when there is a proportional controller present is less sensitive to the lead times. In summary, the proportional controller is an effective mechanism for reducing system nervousness.

*c) How do future orders and order call-offs affect the orders and inventory levels in a supply chain?*

The thesis explicitly analysed the performance of bullwhip and  $NSAmp$  in different echelons of a supply chain. We assumed the manufacturers in all three scenarios apply the OUT policy and use the information provided by the retailer.

Analytical results have proved that the POUT policy and the PFG produce less net stock amplification than the POUT and demand forecasts. If the lead-time  $T_p$  is an odd number and

the proportional controller  $T_i > 1$ , then for any demand correlation  $\rho$ ,  $\sigma_{ns_2,C}^2 < \sigma_{ns_2,B}^2 < \sigma_{ns_2,A}^2$ . More reduction in the upstream net stock variance can be achieved when the demand correlation over time is high or by setting a larger controller value. However, there is a trade-off to be made between the downstream inventory and the upstream inventory.

By setting  $T_i^{-1} < 1 - \rho$ , the retailer's order variance to be less than the variance of consumer demand with the POUT policy, suggesting there is no bullwhip. The detailed behaviour of the manufacturer's order variance have also been analysed in this thesis. If the retailer uses the POUT and the PFG, it is always possible to ensure that the manufacturer's order variance will be no greater than consumer demand variance for all lead-times and for any demand correlations. Although the behaviour of the manufacturer's order variance in Scenario B is relatively complex, we have shown that the order variance at the manufacture in Scenario A is always larger than in Scenario B and C when  $T_i > 1$ . Therefore, the supply chain can benefit from a retailer using the POUT policy and the PFG.

By analysing a new proportional method to produce more accurate order forecasts, this thesis has proved that the system nervousness in the upstream players can be reduced whilst eliminating the bullwhip effect in the supply chain. The PFG method does not require the sharing of consumer demand information. It is also shown for the first time that the nervousness, the inventory variance at the manufacturer, the order variance at both the retailer and the manufacturer, are all decreasing in the proportional controller  $T_i$ , when  $T_i > 1$  and  $T_p$  is odd.

## 8.3 Implications and limitations

### 8.3.1 DT / OUT

Damped Trend forecasting has much potential in academia and in industry for many reasons. It is a powerful and very general forecasting approach as tuning the DT parameters effectively automates model selection. The accuracy of the method has been acknowledged for over two decades. Both the Damped Trend forecasting method and the Order-Up-To replenishment policy can be used not only with stationary demands, but also through the entire product life cycle containing different trends. Therefore, this research has investigated the DT forecasting in the inventory replenishment system based on general demand cases. This is important as previous studies in the field of inventory control generally assume that the demand structure is known, its parameters are known, or an accurate forecast can be provided, when demand in the real world, of course, always needs to be forecasted.

Forecasting research, on the other hand, assumes that forecasting is an end in itself, whilst forecasts are inputs to a decision making model. The thesis has integrated the Damped Trend forecasting into the Order-Up-To policy and revealed the bullwhip avoidance behaviour of the DT / OUT system. It is exceptional because usually forecasting is believed to be one of the causes of the bullwhip effect. It is also worth mentioning that those unconventional parameter values that eliminate the bullwhip effect also reduce the net stock amplification in supply chains.

The majority of studies in the academic literature that consider forecasting and inventory control tend to ignore the effect of using estimated forecasting parameters (Strijbosch et al., 2013). This thesis went into an alternative route. It did not explicitly consider the accuracy of forecasts, instead, it emphasised the importance of supply chain dynamics. In this thesis, even though the conventionally suggested forecasting parameters  $\{0 \leq \phi \leq 1, 0 \leq \alpha \leq 1, 0 \leq \beta \leq 1\}$

could produce the best accuracy, it inevitably induces the bullwhip effect when used in the OUT policy. On the contrary, unconventional parameter values from the region  $\{0 < \phi < 1, \frac{\phi-1}{\phi} < \alpha < 0, \frac{\phi-1}{\phi} < \beta < \frac{-1}{\phi}\}$ , might not produce accurate forecasts, but would be able to eliminate the bullwhip effect and to reduce the inventory variance. This research contributes to the literature by providing both a theoretical proof and simulated verification to that fact. It also develops our understanding on the interaction between forecasting and stock control. There is strong evidence that it is possible to design a production and inventory control system with good financial performance without first directly looking into the performance of forecasting. There could have been more research on this aspect.

Nevertheless, it is somewhat difficult to explain the meaning of unconventional parameter values from a forecasting perspective. One might argue that the research was conducted not from forecasting perspective but from supply chain dynamics perspective. Thus, the forecasting consideration was not embodied in the first place. It is also worth to note that the DT system is stable over these negative parameter values, and a stable DT forecasting method always produces feasible forecasts, despite that those unconventional values are difficult to be explained.

The research, indeed, could be more comprehensive by considering the forecasting perspective at the same time. We understand one forecasting method outperforms another in terms of forecasting accuracy does not mean that this benefit will be carried forward to other metrics such as inventory costs, capacity costs, and service measures. But forecasting is still important for other diagnostic purposes. Similar suggestions have been proposed in the literature, for example, in the area of economics and finance, Timmermann and Granger (2004) highlight the need to evaluate forecast results with regards to the utility of these forecasts. Therefore, we could ask questions like, what is the forecasting

performance when we choose unconventional parameter values. It is worthwhile to explicitly investigate the interactions between forecasting and inventory control since the performance of supply chain dynamics depends on it. This could be achieved by adopting the state space representation of the Damped Trend forecasting model. It might fully explain the reasons behind the superior supply chain performance demonstrated here in a more logical and accessible fashion.

If we could further understand why the behaviour of the DT forecasts is able to achieve such good supply chain performance, then it might be possible to engineer similar supply chain dynamics by artificially designing such forecasts. This research could also be extended by studying the relationship between the bullwhip effect and the net stock amplification in the DT / OUT system. Such relations in the POUT system have been studied by Disney et al. (2004), and they found there is a trade-off between the bullwhip and net stock amplification. Moreover, an intelligent system such as an adaptive DT / OUT policy that automatically tunes its parameter values might be useful for practical purposes.

### **8.3.2 POUT and PFG**

The odd-even lead-time effects are observed not only in the DT / OUT policy, but also in the nervousness and the order and inventory variance when the POUT policy and the PFG mechanism are used. The results showed that odd lead times allow organisations to achieve better inventory control and production planning for negatively correlated demand. This is a form of temporal aggregation as the odd lead time and the review period means that an even number of negatively correlated demand are aggregated into the order-up-to level, effectively reducing the variance introduced into the inventory position feedback loop of the OUT policy.

The choice of AR(1) demand and Order-Up-To policy are not accidental. Erkip et al. (1990) found that the demand of consumer products are often correlated over time with  $\rho$  as high as 0.7. Lee et al. (1997a) argued that non-negative  $\rho$  is common in high-tech industry. Lee et al. (2000) also examined the sales patterns of 150 SKUs at a supermarket over a two-year period, and all had a positive  $\rho$  that varies from 0.26 to 0.89. The OUT policy is a popular algorithm in high volume industries and present in many commercial MRP systems. Therefore, the findings of nervousness, order and inventory variance for  $\rho \geq 0$  suggest much potential in practice.

Although we assumed in the thesis that there is no demand information sharing, the research conducted has wider implications. The future guidance can be easily produced by the downstream players. It also can be the result of collaborative planning, forecasting and replenishment (CPFR). The thesis did not discuss which information should be shared, but is concerned with how to produce valuable order forecasts information that can be shared throughout the supply chain. The POUT policy with the PFG mechanism does not necessarily require the sophisticated integrated IT system that the POS sharing strategy does.

There are many more open research issues that remain to be examined. First, while the research noticed that there is a fundamental trade-off between the retailer's and the manufacturer's inventory. We did not use multi-objective optimisation to balance the competing objectives – low bullwhip, low nervousness, low inventory variance at the retailer and the manufacturer. Second, research can be conducted via Fast Fourier Transform, frequency response analysis and other methods used in Chapter 5 and 6, to analyse the nervousness, the bullwhip effect and the net stock amplification for more general demand cases. The system nervousness of the DT / OUT policy is also worth investigating. Next, the research could be extended by applying alternative production planning algorithms in the

manufacturer. It would be interesting to compare the performance of the nervousness and the bullwhip when different information sharing strategies were applied.

## **8.4 Summary**

This chapter has brought the thesis to the end, by highlighting the overall findings related to the research questions. The limitations of the study were also discussed along with future research opportunities. Despite the limitations, this thesis has provided valuable and rigorous findings for supply chain dynamics research. We can summarise these as the follow:

Although forecasting is believed to be one of the main reasons of the bullwhip effect, this research has found that the Damped Trend forecasting when used in the Order-Up-To policy is able to achieve good supply chain dynamics with less bullwhip and less net stock amplification, providing the forecasting system is carefully designed. It opened up the possibility to design a forecasting system from a production and inventory control system perspective rather than first focusing on forecasting accuracy alone.

Moreover, it is also possible to reduce the system nervousness and the bullwhip effect in supply chains simultaneously. By using the Proportional Order-Up-To policy and the Proportional Future Guidance technique, not only will the system nervousness be reduced, but also the supply chain dynamics can be improved. In other words, the combination of the POUT policy and the PFG method is a valuable tool for coordinating supply chains.



## 9. References

Aburto, L., Weber, R., 2007. Improved supply chain management based on hybrid demand forecasts. *Applied Soft Computing* 7 (1): 136–144.

Acar, Y., Gardner Jr., E.S., 2012. Forecasting method selection in a global supply chain. *International Journal of Forecasting* 28 (4): 842–848.

Aepfel, T., 2010. ‘Bullwhip’ hits firms as growth snaps back. *Wall Street Journal – Eastern Edition* 255 (21): A1–A6.

Aggelogiannaki, E., Doganis, P., Sarimveis, H., 2008. An adaptive model predictive control configuration for production-inventory systems. *International Journal of Production Economics* 114 (1): 165–178.

Akkermans, H.A., Vos, B., 2003. Amplification in service supply chain: an exploratory case study from the telecom industry. *Production and Operations Management* 12 (2): 204–223.

Akkermans, H.A., Voss, C., 2013. The service bullwhip effect. *International Journal of Operations & Production Management* 33 (6): 765–788.

Anderson, E.G., Morrice, D.J., Lundeen, G., 2005. The physics of capacity and backlog management in service and custom manufacturing supply chains. *System Dynamics Review* 21 (3): 217–247.

Armstrong, J.S., 1986. Research on forecasting: a quarter-century review, 1960-1984. *Interfaces* 16: 52–66.

- Armstrong, J.S., 2006. Findings from evidence-based forecasting: methods for reducing forecast error. *International Journal of Forecasting* 22 (3): 583–598.
- Armstrong, J.S., Fildes, R., 2006. Making progress in forecasting. *International Journal of Forecasting* 22: 433–441.
- Asl, F.M., Ulsoy, A.G., 2003. Analysis of a system of linear delay differential equations. *Journal of Dynamic Systems, Measurement and Control* 125 (1): 215–222.
- Axsäter, S., 1985. Control theory concepts in production and inventory control. *International Journal of Systems Science* 16 (2): 161–169.
- Axsäter, S., 2006. *Inventory Control*. Springer: New York, USA.
- Babai, M.Z., Ali, M.M., Boylan, J.E., Syntetos, A.A., 2013. Forecasting and inventory performance in a two-stage supply chain with ARIMA(0,1,1) demand: theory and empirical analysis. *International Journal of Production Economics* 143 (2): 463–471.
- Bellman, R., 1954. The theory of dynamic programming. *Bulletin of the American Mathematical Society* 60 (6): 503–515.
- Berinato, S., 2001. What went wrong at Cisco in 2001? *CIO* 1 August 2001. 52–58.
- Berry, D., Naim, M.M., Towill, D.R., 1995. Business process re-engineering an electronic supply chain. *Proc. IEE Science, Measurement and Technology* 142 (5): 395–403.
- Bissell, C.C., 1996. *Control Engineering*. 2<sup>nd</sup> ed. London: Chapman & Hall.
- Blackburn, J.D., Kropp, D.H., Millen, R.A., 1986. A comparison of strategies to dampen nervousness in MRP systems. *Management Science* 32 (4): 413–429.

Bonney, M.C., 1994. Trends in inventory management. *International Journal of Production Economics* 35 (1-3): 107–114.

Bottani, E., Montanari, R., Volpi, A., 2010. The impact of RFID and EPC network on the bullwhip effect in the Italian FMCG supply chain. *International Journal of Production Economics* 124 (2): 426–432.

Boute, R.N., Dejonckheere, J., Disney, S.M., Van de Velde, W., 2012. Bullwhip in a multi-product production setting. *Tijdschrift voor Economie en Management – Review of Business and Economic Literature* 57 (3): 351–377.

Box, G.E.P., Jenkins, G.M., Reinsel, G.C., 2008. *Time Series Analysis*. 4<sup>th</sup> ed. Hoboken, New Jersey: John Wiley & Sons.

Boyland, J.E., 2007. Key assumptions in calculating the cost of forecast errors. *Foresight: The International Journal of Applied Forecasting* 8: 22–24.

Brenner, J.L., D’Esopo, D.A., Fowler, A.G., 1968. Difference equations in forecasting formulas. *Management Science* 15 (3): 141–159.

Buck, J.R., Hill, T.W., 1971. Laplace transforms for the economic analysis of deterministic problems in engineering. *The Engineering Economist* 16 (4): 247–263.

Burbidge, J.L., 1991. Period batch control (PBC) with GT – the way forward from MRP. Presented at: *the BPICS Annual Conference*, Birmingham.

Burbidge, J.L., 1996. *Period Batch Control*. New York: Oxford University Press.

Burgess, K., Singh, P.L., Koroglu, R., 2006. Supply chain management: a structured literature review and implications for future research. *International Journal of Operations & Production Management* 26 (7): 703–729.

Cachon, G., Fisher, M., 2000. Supply chain inventory management and the value of shared information. *Management Science* 46 (8): 1032–1048.

Campbell, K.L., 1971. Scheduling is not the problem. *Production and Inventory Management* 12 (3): 53–77.

Cannella, S., Ashayeri, J., Miranda, P.A., 2014. Current economic downturn and supply chain: the significance of demand and inventory smoothing. *International Journal of Computer Integrated Manufacturing* 27 (3): 201–212.

Cannella, S., Ciancimino, E., 2010. On the bullwhip avoidance phase: supply chain collaboration and order smoothing. *International Journal of Production Research* 48 (22): 6739–6776.

Cao, M., Vonderembse, M.A., Zhang, Q., Ragu-Nathan, T.S., 2010. Supply chain collaboration: conceptualisation and instrument development. *International Journal of Production Research* 48 (22): 6613–6635.

Carlson, R.C., Beckman, S.L., Kropp, D.H., 1982. The effectiveness of extending the horizon in rolling production scheduling. *Decision Sciences* 13 (1): 129–146.

Carlson, R.C., Jucker, J.V., Kropp, D.H., 1979. Less nervous MRP system: a dynamic economic lot-sizing approach. *Management Science* 25 (8): 754–761.

Chatfield, D.C., Kim, J.G., Harrison, T.P., Hayya, J.C., 2004. The bullwhip effect – the impact of stochastic lead time, information quality, and information sharing: a simulation study. *Production & Operations Management* 13 (4): 340–353.

- Chen, F., Drezner, Z., Ryan, J.K., Simchi-Levi, D., 2000a. Quantifying the bullwhip effect in a simple supply chain: the impact of forecasting, lead-times and information. *Management Science* 46 (3): 436–443.
- Chen, F., Ryan, J.K., Simchi-Levi, D., 2000b. The impact of exponential smoothing forecasts on the bullwhip effect. *Naval Research Logistics* 47 (4): 269–286.
- Chiang, C., 2001. A note on optimal policies for a periodic inventory with emergency orders. *Computers and Operations Research* 28 (2): 93–103.
- Choi, T.M., Hui, C.L., Ng, S., Yu, Y., 2012. Color trend forecasting of fashionable products with very few historical data. *IEEE Transactions on Systems, Man, and Cybernetics – Part C: Applications and Reviews* 42 (6): 1003–1010.
- Cooper, M.C., Lambert, D.M., Pagh, J.D., 1997. Supply chain management more than a new name for logistics. *The International Journal of Logistics Management* 8 (1): 1–14.
- Coppini, M., Rossignoli, C., Rossi, T., Strozzi, F., 2010. Bullwhip effect and inventory oscillations analysis using the beer game model. *International Journal of Production Research* 48 (13): 3943–3956.
- Croson, R., Donohue, K., 2002. Experimental economics and supply-chain management. *Interfaces* 32 (5): 74–82.
- Croson, R., Donohue, K., 2003. Impact of POS data sharing on supply chain management: an experimental study. *Production and Operations Management* 12 (1): 1–11.
- Croson, R., Donohue, K., 2006. Behavioral causes of the bullwhip effect and the observed value of inventory information. *Management Science* 52 (3): 323–336.
- Daganzo, C.F., 2004. On the stability of supply chains. *Operations Research* 52 (6): 909–921.

De Bodt, M.A., Van Wassenhove, L.N., 1983. Cost increases due to demand uncertainty in MRP lot sizing. *Decision Sciences* 14 (3): 345–362.

De Kok, T., Janssen, F., Van Doremalen, J., Van Wachem, E., Clerkx, M., Peeters, W., 2005. Philips Electronics synchronizes its supply chain to end the bullwhip effect. *Interfaces* 35 (1): 37–48.

Dejonckheere, J., Disney, S.M., Lambrecht, M.R., Towill, D.R., 2003. Measuring and avoiding the bullwhip effect: A control theoretic approach. *European Journal of Operational Research* 147 (3): 567–590.

Dejonckheere, J., Disney, S.M., Lambrecht, M.R., Towill, D.R., 2004. The impact of information enrichment on the bullwhip effect in supply chains: A control engineering perspective. *European Journal of Operational Research* 153 (3): 727–750.

Denzin, N.K., Lincoln, Y.S., 1994. *Handbook of Qualitative Research*. Thousand Oaks, CA: Sage Publications.

Disney, S.M., 2001. *The Production and Inventory Control Problem in Vendor Managed Inventory Supply Chains*. PhD Thesis, The University of Wales, Cardiff.

Disney, S.M., 2008. Supply chain aperiodicity, bullwhip and stability analysis with Jury's inners. *IMA Journal of Management Mathematics* 19 (2): 101–116.

Disney, S.M., Farasyn, I., Lambrecht, M.R., Towill, D.R., Van de Velde, W., 2006. Taming the bullwhip effect whilst watching customer service in a single supply chain echelon. *European Journal of Operational Research* 173 (1): 151–172

Disney, S.M., Hoshiko, L., Polley, L., Weigel, C., 2013. Removing bullwhip from Lexmark's toner operations. *Production and Operations Management Society Annual Conference*, May 3<sup>rd</sup>-6<sup>th</sup>, Denver, USA, 10 pages.

Disney, S.M., Lambrecht, M., Towill, D.R., Van de Velde, W., 2008. The value of coordination in a two echelon supply chain: Sharing information, policies and parameters. *IIE Transactions* 40 (3): 341–355.

Disney, S.M., Lambrecht, M.R., 2007. On replenishment rules, forecasting, and the bullwhip effect in supply chains. *Foundations and Trends in Technology, Information and Operations Management* 2 (1): 1–80.

Disney, S.M., Naim, M.M., Potter, A., 2004. Assessing the impact of e-business on supply chain dynamics. *International Journal of Production Economics* 89 (2): 109–118.

Disney, S.M., Towill, D.R., 2002. A discrete transfer function model to determine the dynamic stability of a vendor managed inventory supply chain. *International Journal of Production Research* 40 (1): 179–204.

Disney, S.M., Towill, D.R., 2003. On the bullwhip and inventory variance produced by an ordering policy. *OMEGA: The International Journal of Management Science* 31 (3): 157–167.

Disney, S.M., Towill, D.R., 2005. Eliminating drift in inventory and order based production control systems. *International Journal of Production Economics* 93-94: 331–344.

Disney, S.M., Towill, D.R., Van de Velde, W., 2004. Variance amplification and the golden ratio in production and inventory control. *International Journal of Production Economics* 90 (3): 295–309.

Disney, S.M., Towill, D.R., Warburton, R.D.H., 2006. Taming the bullwhip effect whilst watching customer service in a single echelon of a supply chain. *European Journal of Operational Research* 173 (1): 151–172.

Dooley, K.J., Yan, T., Hohan, S., Gopalakrishnan, M., 2010. Inventory management and the bullwhip effect during the 2007-2009 recession: evidence from the manufacturing sector. *Journal of Supply Chain Management* 46 (1): 12–18.

Edghill, J.S., Towill, D.R., 1989. The use of system dynamics in manufacturing systems engineering. *Transactions of the Institute of Measurement and Control* 11 (4): 208–216.

Erkip, N., Hausman, W.H., Nahmias, S., 1990. Optimal centralized ordering policies in multi-echelon inventory systems with correlated demands. *Management Science* 36 (3): 381–392.

Eshlaghy, A.T., Razavi, M. 2011. Modelling and simulating supply chain management. *Applied Mathematical Sciences* 5 (17): 817–828.

Evans, G.N., Naim, M.M., Towill, D.R., 1994. Applications of a simulation methodology to the redesign of a logistical control system. *International Journal of Production Economics* 56-57: 157–168.

Fildes, R., 1979. Quantitative forecasting - the state of the art: extrapolative methods. *Journal of the Operational Research Society* 30: 691–710.

Fildes, R., Nikolopoulos, K., Crone, S., Syntetos, A., 2008. Forecasting and operational research: a review. *Journal of the Operational Research Society* 59 (9): 1150–1172.

Forrester, J., 1958. Industrial dynamics: a major breakthrough for decision makers. *Harvard Business Review* 36: 37–66.



Forrester, J., 1961. *Industrial Dynamics*. Cambridge MA: MIT Press.

Forrester, J.W., 1961. *Industrial Dynamics*. Cambridge, Mass: M.I.T. Press.

Frankel, R., Naslund, D., Bolumole, Y., 2005. Entering the white space of logistics research. *Journal of Business Logistics* 26 (2): 185–209.

Frohlich, M.T., Westbrook, R., 2002. Demand chain management in manufacturing and services: web-based integration, drivers and performance. *Journal of Operations Management* 20 (6): 729–745.

Gaalman, G., 2006. Bullwhip reduction for ARMA demand: the proportional order-up-to policy versus the full-state-feedback policy. *Automatica* 42 (8): 1283-1290.

Gaalman, G., Disney, S.M., 2006. State space investigation of the bullwhip problem with ARMA(1,1) demand processes. *International Journal of Production Economics* 104 (2): 327–339.

Gaalman, G., Disney, S.M., 2009. On the bullwhip in a family of order-up-to policies with ARMA(2,2) demand and arbitrary lead-times. *International Journal of Production Economics* 121 (2): 454–463.

Gaalman, G., Disney, S.M., 2012. Bullwhip behaviour in the Order-Up-To policy with ARIMA demand. In: *Proceedings of the 4<sup>th</sup> World Production and Operations Management Conference*, Amsterdam, The Netherlands, 1<sup>st</sup>-5<sup>th</sup> July.

Ganesh, M., Raghunathan, S. Rajendran, C., 2014. The value of information sharing in a multi-product, multi-level supply chain: impact of product substitution, demand correlation, and partial information sharing. *Decision Support Systems* 58: 79–94.

Gardner Jr., E.S., 1985. Exponential smoothing: the state of the art. *Journal of Forecasting* 4 (1): 1–28.

Gardner Jr., E.S., 1990. Evaluating forecast performance in an inventory control system. *Management Science* 36 (4): 490–499.

Gardner Jr., E.S., 2006. Exponential smoothing: the state of the art – part II. *International Journal of Forecasting* 22: 637–666.

Gardner Jr., E.S., McKenzie, E., 1985. Forecasting trends in time series. *Management Science* 31 (10): 1237–1246.

Gardner Jr., E.S., McKenzie, E., 1988. Model identification in exponential smoothing. *Journal of the Operational Research Society* 39 (9): 863–867.

Gardner Jr., E.S., McKenzie, E., 1989. Seasonal exponential smoothing with damped trends. *Management Science* 35 (3): 372–376.

Gardner Jr., E.S., McKenzie, E., 2011. Why the damped trend works. *Journal of the Operational Research Society* 62 (6): 1177–1180.

Geary, S., Disney, S.M., Towill, D.R., 2006. On bullwhip in supply chain – historical review, present practice and expected future impact. *International Journal of Production Economics* 101 (1): 2–18.

Gilbert, K., 2005. An ARIMA supply chain model. *Management Science* 51 (2): 305–310.

Gilchrist, W.G., 1976. *Statistical Forecasting*. London: Wiley.

Gorham, T., 1968. Dynamic order quantities. *Production and Inventory Management* 9 (1): 75–81.

- Granger, C.W.J., Lee, T.H., 1989. Investigation of production, sales and inventory relationships using multicointegration and non symmetric error correction models. *Journal of Applied Econometrics* 4 (S1): S145–S159.
- Grasso, E.T., Taylor, B.W., 1984. A simulation based experimental investigation of supply / timing uncertainty in MRP system. *International Journal of Production Research* 22 (3): 485–497.
- Graves, S.C., Willems, S.P., 2005. Optimizing the supply chain configuration for new products. *Management Science* 51 (8): 1165–1180.
- Grubbström, R.W., 1967. On the application of the Laplace transform to certain economic problems. *Management Science* 13 (7): 558–567.
- Grubbström, R.W., 2005. Algorithms for optimal dynamic lot-sizing in discrete and continuous time. *International Journal of Agile Manufacturing* 8 (2): 85–96.
- Grubbström, R.W., Molinder, A., 1996. Safety production plans in MRP-systems using transform methodology. *International Journal of Production Economics* 46-47: 297–309.
- Grunwald, H.J., Fortuin, L., 1992. Many steps towards zero inventory. *European Journal of Operational Research* 59 (3): 359–369.
- Hall, N.G., Potts, C.N., 2003. Supply chain scheduling: batching and delivery. *Operations Research* 51 (4): 566–584.
- Hanssens, D.M., 1998. Order forecasts, retail sales and the marketing mix for consumer durables. *Journal of Forecasting* 17 (3-4): 327–346.
- Harrison, A., 1997. Investigating the sources and causes of schedule instability. *International Journal of Logistics Management* 8 (2): 75–82.

Harrison, P.J., 1967. Exponential smoothing and short-term sales forecasting. *Management Science* 13: 821–842.

Harvey, A.C., 1984. A unified view of statistical forecasting procedures. *Journal of Forecasting* 3: 245–275.

Hassanzadeh, A., Jafarian, A., Amiri, M., 2014. Modeling and analysis of the causes of bullwhip effect in centralized and decentralized supply chain using response surface method. *Applied Mathematical Modelling* 38 (9-10): 2353–2365.

Hayes, R.H., Clark, K.B., 1985. Explaining observed productivity differentials between plants: implications for operations research. *Interfaces* 15 (6): 3–14.

Hendry, L.C., Kingsman, B.G., 1989. Production planning systems and their applicability to make-to-order companies. *European Journal of Operational Research* 40 (1): 1–15.

Ho, C.-J., 2005. Examining dampening effects for alternative dampening procedures to cope with system nervousness. *International Journal of Production Research* 43 (19): 4009–4033.

Ho, C.-J., Carter, P.L., 1996. An investigation of alternative dampening procedures to cope with MRP system nervousness: a simulation study. *International Journal of Production Research* 34 (1): 137–156.

Ho, C.-J., Ireland, T.C., 1998. Correlating MRP system nervousness with forecast errors. *International Journal of Production Research* 36 (8): 2285–2299.

Holt, C.C., 2004. Forecasting seasonals and trends by exponential weighted moving average. *International Journal of Forecasting* 20 (1): 5–10.

Holweg, H., Disney, S.M., Holmström, J., Småros, J., 2005. Supply chain collaboration: Making sense of the strategy continuum. *European Management Journal* 23 (2): 170–181.

- Hong-Ming, S.M., Disney, S.M., Naim, M.M., 2000. The dynamics of emergency transshipment supply chains. *International Journal of Physical Distribution & Logistics Management* 30 (9): 788–815.
- Hosoda, T., Disney, S.M., 2006. The governing dynamics of supply chains: the impact of altruistic behaviour. *Automatica* 42 (8): 1301–1309.
- Hosoda, T., Disney, S.M., 2009. Impact of market demand mis-specification on a two-level supply chain. *International Journal of Production Economics* 121 (2): 739–751.
- Houlihan, J.B. 1987. International supply chain management. *International Journal of Physical Distribution and Materials Management* 17 (2): 51–66.
- Hsu, C.-C., Kannan, V.R., Tan, K.C., Leong, G.K., 2008. Information sharing, buyer-supplier relationships, and firm performance: a multi-region analysis. *International Journal of Physical Distribution & Logistics Management* 38 (4): 296–310.
- Huo, B., Zhao, X., Zhou, H., 2014. The effects of competitive environment on supply chain information sharing and performance: an empirical study in China. *Production and Operations Management* 23 (4): 552–569.
- Hussain, M., Drake, P.R., Lee, D.M., 2012. Quantifying the impact of a supply chain's design parameters on the bullwhip effect using simulation and Taguchi design of experiments. *International Journal of Physical Distribution & Logistics Management* 42 (10): 947–968.
- Jiang, J.J., Maosen, Z., Klein, G., Chen, H.G., 2004. Nonstationary brand variables in category management: a cointegration perspective. *Decision Sciences* 35 (1): 101–128.
- Jiang, J.J., Zhong, M., Klein, G., 2000. Marketing category forecasting: an alternative of BVAR-artificial networks. *Decision Sciences* 31 (4): 789–812.

John, S., Naim, M.M., Towill, D.R., 1994. Dynamic analysis of a WIP compensated decision support system. *International Journal of Manufacturing System Design* 1 (4): 283–297.

Jury, E.I., 1971. Inners approach to some problems of system theory. *IEEE Transactions on Automatic Control* 16 (3): 233–240.

Jury, E.I., 1974. *Inners and Stability of Dynamic Systems*. New York: John Wiley.

Kadipasaoglu, S.N., Sridharan, V., 1995. Alternative approaches for reducing schedule instability in multistage manufacturing under demand uncertainty. *Journal of Operations Management* 13 (3): 193–211.

Kahn, J.A., 1987. Inventories and the volatility of production. *The American Economic Review* 77 (4): 667–679.

Kropp, D.H., Carlson, R.C., 1984. A lot-sizing algorithm for reducing nervousness in MRP systems. *Management Science* 30 (2): 240–244.

Kropp, D.H., Carlson, R.C., Jucker, J.V., 1983. Heuristic lot-sizing approaches for dealing with MRP system nervousness. *Decision Sciences* 14 (2): 156–169.

Lalwani, C.S., Disney, S.M., Towill, D.R., 2006. Controllable, observable and stable state space representations of a generalised Order-Up-To policy. *International Journal of Production Economics* 101 (1): 173–184.

Lambert, D.M., Cooper, M.C., 2000. Issues in supply chain management. *Industrial Marketing Management* 29: 65–83.

Lapide, L., 1999. Multi tier forecasting: a way to improve accuracy. *Journal of Business Forecasting* 18 (4): 12–14.

Lee, H.L., Padmanabhan, V., Whang, S., 1997a. Information distortion in a supply chain: the bullwhip effect. *Management Science* 43 (4): 546–558.

Lee, H.L., Padmanabhan, V., Whang, S., 1997b. The bullwhip effect in supply chains. *Sloan Management Review* 38 (3): 93–102.

Lee, H.L., So, K.C., Tang, C.S., 2000. The value of information sharing in a two-level supply chain. *Management Science* 46 (5): 626–643.

Lee, H.L., Whang, S., 2000. Information sharing in a supply chain. *International Journal of Technology Management* 1 (1): 79–93.

Lewandowski, R., 1982. Sales forecasting by FORSYS. *Journal of Forecasting* 1, 205–214.

Li, J., Sikora, R., Shaw, M.J., Tan, W., 2006. A strategic analysis of inter organisational information sharing. *Decision Support Systems* 42 (1): 251–266.

Li, R., Ryan, J.K., 2012. Inventory flexibility through adjustment contracts. *International Journal of Production Research* 50 (7): 1955–1978.

Lin, C.-Y., Sheu, S.-H., Hsu, T.-S., Chen, Y.-C., 2013. Application of generally weighted moving average method to tracking signal state space model. *Expert Systems* 30 (5): 429–435.

Lin, K.-P., Chang, P.-T., Hung, K.-C., Pai, P.-F., 2010. A simulation of vendor managed inventory dynamics using fuzzy arithmetic operations with genetic algorithms. *Expert Systems with Applications* 37 (5): 2571–2579.

Lin, W.-J., Jiang, Z.-B., Liu, R., Wang, L., 2014. The bullwhip effect in hybrid supply chain. *International Journal of Production Research* 52 (7): 2062–2084.

- Lummus, R.R., Krumwiede, D.W., Vokurka, R.J., 2001. The relationship of logistics to supply chain management: developing a common industry definition. *Industrial Management and Data Systems* 101 (8): 426–432.
- Mahmoud, E., Pegels, C.C., 1989. An approach for selecting time series forecasting models. *International Journal of Operations & Production Management* 10: 50–60.
- Makridakis, S., Andersen, A., Carbone, R., Fildes, R., Hibon, M., Lewandowski, R., Newton, J., Parzen, R., Winkler, R., 1982. The accuracy of extrapolation (time series) methods: results of a forecasting competition. *Journal of Forecasting* 1 (1): 11–153.
- Makridakis, S., Hibon, M., 1979. Accuracy of forecasting: an empirical investigation (with discussion). *Journal of the Royal Statistical Society* 142: 97–145.
- Makridakis, S., Hibon, M., 2000. The M3-competition: results, conclusions and implications. *International Journal of Forecasting* 16 (4): 451–476.
- Makridakis, S., Wheelwright, S.C., McGee, V.E., 1983. *Forecasting: Methods and Applications*. 2<sup>nd</sup> ed. Chichester: John Wiley & Sons.
- Mason-Jones, R., Naim, M.M., Towill, D.R., 1997. The impact of pipeline control on supply chain dynamics. *International Journal of Logistics Management* 8 (2): 47–62.
- Mason-Jones, R., Towill, D.R., 1997. Information enrichment: designing the supply chain for competitive advantage. *Supply Chain Management: An International Journal* 2 (4): 137–148.
- Mather, H., 1977. Reschedule the reschedules you just rescheduled – way of life for MRP? *Production and Inventory Management* 18 (1): 60–79.
- McClain, J.O., Thomas, L.J., 1973. Response-variance tradeoffs in adaptive forecasting. *Operations Research* 21 (2): 554–568.



McKenzie, E., Gardner Jr., E.S., 2010. Damped trend exponential smoothing: a modelling viewpoint. *International Journal of Forecasting* 26 (4): 661–665.

Melnyk, S.A., Zobel, C.W., Macdonald, J.R., Griffis, S.E., 2014. Making sense of transient responses in simulation studies. *International Journal of Production Research* 52 (3): 617–632.

Mentzer, J.T., DeWitt, W.J., Keebler, J.S., Min, S., Nix, N.W., Smith, C.D., Zacharia, Z.G., 2001. Defining supply chain management. *Journal of Business Logistics* 22 (2): 1–25.

Mentzer, J.T., Kahn, K.B., 1995. A framework for logistics research. *Journal of Business Logistics* 16 (1): 231–251.

Meredith, J.R., 2001. Reconsidering the philosophical basis of OR/MS. *Operations Research* 49 (3): 325–333.

Meredith, J.R., Raturi, A., Amoako-Gyampah, K., Kaplan, B., 1989. Alternative research paradigms in operations. *Journal of Operations Management* 8 (4): 297–326.

Mohr, J., Spekman, R., 1994. Characteristics of partnership success: partnership attributes, communication behaviour, and conflict techniques. *Strategic Management Journal* 15 (2): 135–152.

Naim, M.M., Towill, D.R., 1995. What's in the pipeline? *Proceedings of the 2<sup>nd</sup> International Symposium on Logistics*, 11-12 July, 135–142.

Nise, N.S., 2004. *Control Systems Engineering*. 4<sup>th</sup> ed. Hoboken, New Jersey: John Wiley & Sons.

Olsmats, C., Edghill, J.S. Towill, D.R., 1988. Industrial dynamics model building of a close-coupled production-distribution system. *Engineering Costs and Production Economics* 13: 295–310.

Orlicky, J.A., 1976. Rescheduling with tomorrow's MRP system. *Production and Inventory Management* 17 (2): 38–48.

Ouyang, Y., Daganzo, C., 2006. Characterization of the bullwhip effect in linear, time-invariant supply chains: some formulae and tests. *Management Science* 52 (10): 1544–1556.

Peterson, L.D., 1975. Design considerations for improving the effectiveness of MRP. *Production and Inventory Management* 16 (3): 48–68.

Pilkington, A., Meredith, J.R., 2009. The evolution of the intellectual structure of operations management – 1980-2006: a citation/co-citation analysis. *Journal of Operations Management* 27 (3): 185–202.

Popplewell, K., Bonney, M.C., 1987. The application of discrete linear control theory to the analysis of multi-product, multi-level production control systems. *International Journal of Production Research* 25 (1): 45–56.

Potter, A., Disney, S.M., 2010. Removing bullwhip from the Tesco supply chain. *Production and Operations Management Society Annual Conference*, May 7<sup>th</sup>-10<sup>th</sup>, Vancouver, Canada. Paper No. 015-0397, 19 pages.

Roberts, S.A., 1982. A general class of Holt-Winters type forecasting models. *Management Science* 28 (8): 808–820.

Rotaru, K., Churilov, L., Flitman, A., 2013. Can critical realism enable a journey from description to understanding in operations and supply chain management? *Supply Chain Management: An International Journal* 19 (2): 117–125.

Sachan, A., Datta, S., 2005. Review of supply chain management and logistics research. *International Journal of Physical Distribution & Logistics Management* 35 (9): 664–705.

Sahin, F., Robinson, E.P., 2002. Flow coordination and information sharing in supply chains: review, implications, and directions for future research. *Decision Sciences* 33 (4): 505–537.

Samaddar, S., Nargundkar, S., Marcia, D., 2006. Inter-organizational information sharing: the role of supply chain network configuration and partner goal congruence. *European Journal of Operational Research* 174 (2): 744–765.

Sbrana, G., Silvestrini, A., 2014. Random switching exponential smoothing and inventory forecasting. *International Journal of Production Economics* 156: 283–294.

Schmitt, T.G., 1984. Resolving uncertainty in manufacturing systems. *Journal of Operations Management* 4 (4): 311–345.

Silver, E., Meal, H., 1973. A heuristic for selecting lot size quantities for the case of a deterministic time-varying demand rate and discrete opportunities for replenishment. *Production and Inventory Management* 14 (2): 64–74.

Simchi-Levi, D., Kaminsky, P., Simchi-Levi, E., 2000. *Designing and Managing the Supply Chain: Concepts, Strategies, and Case Studies*. McGraw-Hill.

Simon, H., 1952. On the application of servomechanism theory in the study of production control. *Econometrica* 20 (2): 247–268.

- Snyder, R.D., Koehler, A.B., 2009. Incorporating a tracking signal into a state space model. *International Journal of Forecasting* 25 (3): 526–530.
- Snyder, R.D., Koehler, A.B., Ord, K., 2002. Forecasting for inventory control with exponential smoothing. *International Journal of Forecasting* 18 (1): 5–18.
- Sridharan, V., LaForge, R.L., 1989. The impact of safety stock on schedule instability, cost, and service. *Journal of Operations Management* 8 (4): 327–347.
- Steele, D.C., 1975. The nervous MRP system: how to do battle. *Production and Inventory Management* 16: 83–89.
- Sterman, J., 1989. Modelling managerial behaviour: misperceptions of feedback in a dynamic decision making experiment. *Management Science* 35 (3): 321–339.
- Strijbosch, L.W.G., Syntetos, A.A., Boylan, J.E., Janssen, E., 2011. On the interaction between forecasting and stock control: the case of non-stationary demand. *International Journal of Production Economics* 133: 470–480.
- Syntetos, A.A., Boylan, J.E., 2006. On the stock control performance of intermittent demand estimators. *International Journal of Production Economics* 103: 36–47.
- Syntetos, A.A., Boylan, J.E., 2008. Demand forecasting adjustments for service level achievement. *IMA Journal of Management Mathematics* 19: 175–192.
- Syntetos, A.A., Nikolopoulos, K., Boylan, J.E., 2010. Judging the judges through accuracy-implication metrics: the case of inventory forecasting. *International Journal of Forecasting* 26: 134–143.

- Tang, O., Naim, M.M., 2004. The impact of information transparency on the dynamic behaviour of a hybrid manufacturing/remanufacturing system. *International Journal of Production Research* 42 (19): 4135–4152.
- Tashman, L.J., Kruk, J.M., 1996. The use of protocols to select exponential smoothing procedures: a reconsideration of forecasting competitions. *International Journal of Forecasting* 12 (2): 235–253.
- Taylor, J.W., 2003. Exponential smoothing with a damped multiplicative trend. *International Journal of Forecasting* 19 (4): 715–725.
- Terwiesch, C., Ren, Z.J., Ho, T.H., Cohen, M.A., 2005. An empirical analysis of forecast sharing in the semiconductor equipment supply chain. *Management Science* 51 (2): 208–220.
- Timmermann, A., Granger, C.W.J., 2004. Efficient market hypothesis and forecasting. *International Journal of Forecasting* 20: 15–27.
- Tinker, T., Lowe, T., 1984. One-dimensional management science: the making of a technocratic consciousness. *Interfaces* 14 (2): 40–56.
- Torres, O.C., Maltz, A.B., 2010. Understanding the financial consequences of the bullwhip effect in a multi-echelon supply chain. *Journal of Business Logistics* 31 (1): 23–41.
- Towill, D.R., 1970. *Transfer Function Techniques for Control Engineers*. London: Iliffe.
- Towill, D.R., 1982. Dynamic analysis of an inventory and order based production control system. *International Journal of Production Research* 20 (6): 671–687.
- Towill, D.R., 1988. The dynamic analysis approach to manufacturing system design. *University of Wales Review*.

Towill, D.R., 1994. 1961 and all that: the influence of Jay Forrester and John Burbidge on the design of modern manufacturing systems. *Proceeding in 1994 International System Dynamics Conference on Business Decision Making*, 105–115.

Towill, D.R., Evans, G.N., Cheema, P., 1997. Analysis and design of an adaptive minimum reasonable inventory control system. *Production Planning and Control* 8 (6): 545–557.

Turrisi, M., Bruccoleri, M., Cannella, S., 2013. Impact of reverse logistics on supply chain performance. *International Journal of Physical Distribution & Logistics Management* 43 (7): 564–585.

Uzzi, B., Lancaster, R., 2003. Relational embeddedness and learning: the case of bank loan managers and their clients. *Management Science* 49 (4): 383–399.

Van Ackere, A., Larsen, E.R., Morecroft, J.D.W., 1993. Systems thinking and business process redesign: an application to the Beer Game. *European Management Journal* 11 (4): 412–423.

Vanpoucke, E., Boyer, K.K., Vereecke, A., 2009. Supply chain information flow strategies: an empirical taxonomy. *International Journal of Operations & Production Management* 29 (12): 1213–1241.

Vassian, H.J., 1955. Application of discrete variable servo theory to inventory control. *Journal of Operations Research Society of America* 3 (3): 272–282.

Wadhwa, S., Saxena, A., 2007. Decision knowledge sharing: flexible supply chains in KM context. *Production Planning and Control* 18 (5): 436–453.

Wagner, H.M., Whitin, T.M., 1958. Dynamic version of the economic lot size model. *Management Science* 5 (1): 89–96.

Wang, S.-J., Huang, C.-T., Wang, W.-L., Chen, Y.-H., 2010. Incorporating ARIMA forecasting and service-level based replenishment in RFID-enabled supply chain. *International Journal of Production Research* 48 (9): 2655–2677.

Wangphanich, P., Kara, S., Kayis, B., 2010. Analysis of the bullwhip effect in multi-product, multi-stage supply chain systems – a simulation approach. *International Journal of Production Research* 48 (15): 4501–4517.

Warburton, R.D.H., Disney, S.M., 2007. Order and inventory variance amplification: the equivalence of discrete and continuous time analyses. *International Journal of Production Economics* 110 (1): 128–137.

Wei, Y., Wang, H., Qi, C., 2013. On the stability and bullwhip effect of a production and inventory control system. *International Journal of Production Research* 51 (1): 154–171.

Whybark, D.C., Williams, J.G., 1976. Material requirements planning under uncertainty. *Decision Sciences* 7 (4): 595–606.

Wikner, J., Naim, M.M., Rudberg, M., 2007. Exploiting the order book for mass customized manufacturing control systems with capacity limitations. *IEEE Transactions on Engineering Management* 54 (1): 145–155.

Wikner, J., Naim, M.M., Towill, D.R., 1992. The system simplification approach in understanding the dynamic behaviour of a manufacturing supply chain. *Journal of Systems Engineering* 2: 164–178.

Williams, B.D., Waller, M.A., 2010. Creating order forecasts: point-of-sale or order history? *Journal of Business Logistics* 31 (2): 231–251.

Williams, B.D., Waller, M.A., Ahire, S., Ferrier, G.D., 2014. Predicting retailer orders with POS and order data: the inventory balance effect. *European Journal of Operational Research* 232 (3): 593–600.

Wilson, M., 2007. The impact of transportation disruptions on supply chain performance. *Transportation Research Part E: Logistics and Transportation Review* 43 (4): 295–320.

Winters, P.R., 1960. Forecasting sales by weighted moving averages. *Management Sciences* 6 (3): 324–342.

Wright, D., Yuan, X., 2008. Mitigating the bullwhip effect by ordering policies and forecasting methods. *International Journal of Production Economics* 113 (2): 587–597.

Zhang, X., 2004. The impact of forecasting methods on the bullwhip effect. *International Journal of Production Economics* 88 (1): 15–27.

Zhao, X., Huo, B., Flynn, B., Yeung, J., 2008. The impact of power and relationship commitment on the integration between manufacturers and customers in a supply chain. *Journal of Operations Management* 26 (3): 368–388.

Zhao, X., Huo, B., Selen, W., Yeung, J., 2011. The impact of relationship commitment and internal integration on external integration. *Journal of Operations Management* 29 (1-2): 17–32.

Zhao, X., Lee, T.S., 1993. Freezing the master production schedule for material requirements planning systems under demand uncertainty. *Journal of Operations Management* 11 (2): 185–205.



Zhong, M., Pick, R., Klein, G., Jiang, J., 2011. Vector error-correction models in a consumer packaged goods category forecasting decision support system. *Journal of Computer Information Systems* 46 (1): 25–34.

Zhou, L., Disney, S.M., 2006. Bullwhip and inventory variance in a closed loop supply chain. *OR Spectrum* 28 (1): 127–149.

Zhou, L., Disney, S.M., Towill, D.R., 2010. A pragmatic approach to the design of bullwhip controllers. *International Journal of Production Economics* 128 (2): 556–568.

Zipkin, P.H., 2000. *Foundations of Inventory Management*. New York, USA: McGraw-Hill.

## 10. Appendix: Autocalculation of variance via Jury's Inners

The code below is written in Mathematica ® Wolfram Research to automatically calculate the variance of signals based on Jury's Inners.

```

n = Exponent[Denominator[TF], z];
X = Map[Reverse, HankelMatrix[CoefficientList[Denominator[TF], z]]];
Y = Map[Reverse, Reverse[HankelMatrix[Reverse[CoefficientList[Denominator[TF], z]]]];
an = Coefficient[Denominator[TF], z, n];
Δ = X + Y;
Δb = Δ;
b = CoefficientList[Numerator[TF], z];
t = Table[If[i > j, 0, b[[i]]b[[j]]], {i, n + 1}, {j, n + 1}];
Δb[[n + 1]] = Reverse[Table[2Tr[Drop[t, {n + 1 - i, n + 1}, {1, i + 1}], {i, -1, n - 1}]];

$$\frac{Det[\Delta b]}{an Det[\Delta]} // FullSimplify$$

```

Table 10.1 The Mathematica code to find the variance using Jury's Inners approach

TF is the transfer in the form of

$$\frac{b_0 + b_1 z + b_2 z^2 + \dots + b_m z^m}{a_0 + a_1 z + a_2 z^2 + \dots + a_n z^n} \quad (10.1)$$

Jury (1974) shows that the variance of signals can be represented as

$$Var = \frac{|X_{n+1} + Y_{n+1}|_b}{a_n |X_{n+1} + Y_{n+1}|}, \quad (10.2)$$

where matrices  $X_{n+1}$  and  $Y_{n+1}$  are made up of the coefficients of  $z$  in discrete transfer functions

$$\mathbf{X}_{n+1} = \begin{bmatrix} a_n & a_{n-1} & a_{n-2} & \cdots & a_0 \\ 0 & a_n & a_{n-1} & \cdots & a_1 \\ 0 & 0 & a_n & \cdots & a_2 \\ \vdots & \vdots & \vdots & \ddots & \vdots \\ 0 & 0 & 0 & \cdots & a_n \end{bmatrix}, \quad \mathbf{Y}_{n+1} = \begin{bmatrix} 0 & 0 & 0 & \cdots & a_0 \\ \vdots & \vdots & \vdots & \ddots & \vdots \\ 0 & 0 & a_0 & \cdots & a_{n-2} \\ 0 & a_0 & a_1 & \cdots & a_{n-1} \\ a_0 & a_1 & a_2 & \cdots & a_n \end{bmatrix}, \quad (10.3)$$

and  $[X_{n+1} + Y_{n+1}]_b$  is formed from the matrix  $X_{n+1} + Y_{n+1}$  with the last row replaced by

$$\left[ 2b_n b_0, 2\sum b_i b_{i+n-1}, \dots, 2\sum b_i b_{i+1}, 2\sum_{i=0}^n b_i^2 \right].$$

The Mathematica code first defines the value of  $n$  as the highest power of  $z$  in the denominator. When we collect the coefficients from the denominator and build a Hankel matrix, it is in the form

$$\begin{bmatrix} a_0 & a_1 & \cdots & a_{n-1} & a_n \\ a_1 & a_2 & \cdots & a_n & 0 \\ \vdots & \vdots & \ddots & \vdots & \vdots \\ a_{n-1} & a_n & \cdots & 0 & 0 \\ a_n & 0 & \cdots & 0 & 0 \end{bmatrix}. \quad (10.4)$$

It is easy to recognise that by reversing the order of the entries on every single column on (10.4), we will get the matrix  $X_{n+1}$  in (10.3).

The code in third line reverses the order of  $\{a_0, a_1, a_2, \dots, a_n\}$  and creates another Hankel matrix

$$\begin{bmatrix} a_n & a_{n-1} & \cdots & a_1 & a_0 \\ a_{n-1} & a_{n-2} & \cdots & a_0 & 0 \\ \vdots & \vdots & \ddots & \vdots & \vdots \\ a_1 & a_0 & \cdots & 0 & 0 \\ a_0 & 0 & \cdots & 0 & 0 \end{bmatrix}. \quad (10.5)$$

When we rotate the matrix (10.5)  $180^\circ$ , it is exactly the same matrix as  $Y_{n+1}$ .

After that, the code creates the matrix (10.6) in which the elements are the products of every two coefficients in the numerator with the exception that  $b_i b_j = 0$  when  $i < j$ .

$$\begin{bmatrix} b_0^2 & b_0 b_1 & b_0 b_2 & \cdots & b_0 b_n \\ 0 & b_1^2 & b_1 b_2 & \cdots & b_1 b_n \\ 0 & 0 & b_2^2 & \cdots & b_2 b_n \\ \vdots & \vdots & \vdots & \ddots & \vdots \\ 0 & 0 & 0 & \cdots & b_n^2 \end{bmatrix} \quad (10.6)$$

Then  $\left[ 2b_n b_0, 2\sum b_i b_{i+n-1}, \dots, 2\sum b_i b_{i+1}, 2\sum_{i=0}^n b_i^2 \right]$  is actually the reverse of the list made up of the twice of the sum of the entries on each triangle line in matrix (10.6).

With those matrices, Mathematica can easily calculate the variance of the transfer function (TF in (10.1)).

Jury's Inners method and the Mathematica code provided above are powerful and efficient when we need to calculate variance. The only drawback of this method is that the value of  $n$  has to be specific number instead of a variable. For example, in the ORATE or AINV transfer function of the VMI-APIOBPCS model (Disney and Towill 2002), the highest power of  $z$  in the denominator contains the value of lead-time. In this case, Jury's Inners cannot be applied on the variance calculation for arbitrary lead-time. If the power of  $z$  is known, with the knowledge of the discrete transfer function of a system or signals, the variance is only one click away.

## 11. Appendix: Deriving the measures of order stream accuracy

The call-off order (7.3) generated by the POUT policy can be written as

$$o_t = \left(1 - \frac{1}{T_i}\right) o_{t-1} + \left(\hat{d}_{t,t+T_p+1} - \hat{d}_{t-1,t+T_p}\right) + \frac{1}{T_i} (dwip_t - dwip_{t-1}) + \frac{1}{T_i} d_t. \quad (11.1)$$

As we have a linear system, setting  $\mu = 0$  has no effect on variance expressions. Note

$$d_t = \rho d_{t-1} + \varepsilon_t = \sum_{i=0}^{\infty} \rho^i \varepsilon_{t-i} = \varepsilon_t + \rho \varepsilon_{t-1} + \rho^2 \varepsilon_{t-2} + \dots \quad (11.2)$$

Using (11.2) in (11.1),  $o_t$  can be written as

$$\begin{aligned} o_t &= \left(1 - \frac{1}{T_i}\right) o_{t-1} + \left(\rho^{T_p+1} + \frac{\kappa}{T_i}\right) \varepsilon_t + \rho^{T_p+1} \left(\rho - 1 + \frac{1}{T_i}\right) d_{t-1} \\ &= \left(1 - \frac{1}{T_i}\right) o_{t-1} + \left(\rho^{T_p+1} + \frac{\kappa}{T_i}\right) \varepsilon_t + \rho^{T_p+1} \left(\rho - 1 + \frac{1}{T_i}\right) (\varepsilon_{t-1} + \rho \varepsilon_{t-2} + \rho^2 \varepsilon_{t-3} + \dots), \end{aligned} \quad (11.3)$$

where,  $\kappa = (1 - \rho^{T_p+1}) / (1 - \rho)$ . Substituting (11.3) into itself recursively,

$$\begin{aligned} o_t &= \left(\rho^{T_p+1} + \frac{\kappa}{T_i}\right) \varepsilon_t + \\ &\quad \left(\left(\frac{T_i-1}{T_i}\right) \left(\rho^{T_p+1} + \frac{\kappa}{T_i}\right) + \rho^{T_p+1} \left(\rho - \frac{T_i-1}{T_i}\right)\right) \varepsilon_{t-1} + \\ &\quad \left(\left(\frac{T_i-1}{T_i}\right)^2 \left(\rho^{T_p+1} + \frac{\kappa}{T_i}\right) + \left(\frac{T_i-1}{T_i}\right) \rho^{T_p+1} \left(\rho - \frac{T_i-1}{T_i}\right) + \rho^{T_p+2} \left(\rho - \frac{T_i-1}{T_i}\right)\right) \varepsilon_{t-2} + \\ &\quad \left(\left(\frac{T_i-1}{T_i}\right)^3 \left(\rho^{T_p+1} + \frac{\kappa}{T_i}\right) + \left(\frac{T_i-1}{T_i}\right)^2 \rho^{T_p+1} \left(\rho - \frac{T_i-1}{T_i}\right) + \left(\frac{T_i-1}{T_i}\right) \rho^{T_p+2} \left(\rho - \frac{T_i-1}{T_i}\right) + \rho^{T_p+3} \left(\rho - \frac{T_i-1}{T_i}\right)\right) \varepsilon_{t-3} + \dots \\ &= \sum_{n=0}^{\infty} \left(\left(\frac{T_i-1}{T_i}\right)^n \left(\rho^{T_p+1} + \frac{\kappa}{T_i}\right) + \rho^{T_p+1} \left(\rho^n - \left(\frac{T_i-1}{T_i}\right)^n\right)\right) \varepsilon_{t-n}. \end{aligned} \quad (11.4)$$

The variance of  $o_t$  can be derived by taking the expected value of the square of (11.4),

$$\begin{aligned} \sigma_o^2 &= \sigma_\varepsilon^2 \left( \frac{\kappa^2}{2T_i - 1} + \frac{2\kappa\rho^{1+T_p}}{\rho + T_i(1-\rho)} - \frac{\rho^{2(1+T_p)}}{\rho^2 - 1} \right) \\ &= \sigma_\varepsilon^2 \frac{2\rho^{T_p+1}(1+\rho)\left(\rho + \frac{1-T_i}{T_i}\right) - 2T_i\rho^{2(T_p+1)}\left(\rho + \frac{1-T_i}{T_i}\right)^2 - (1+\rho)\left(1 + \left(\frac{1-T_i}{T_i}\right)\rho\right)}{T_i(1+\rho)(\rho-1)^2\left(\frac{1-2T_i}{T_i}\right)\left(1 + \rho\left(\frac{1-T_i}{T_i}\right)\right)}. \end{aligned} \quad (11.5)$$

When demand is i.i.d. the variance of the retailers orders reduces to  $\sigma_o^2 = \sigma_\varepsilon^2 / (2T_i - 1)$ .

When  $T_i = 1$ , the POUT policy degenerates into the OUT policy. Using this knowledge and setting  $T_i = 1$  in (11.3) and simplifying yields the call-off order for Scenario A,

$$o_t = \left( \rho^{T_p+1} + \kappa \right) \varepsilon_t + \sum_{n=1}^{\infty} \rho^{T_p+1+n} \varepsilon_{t-n}, \quad (11.6)$$

from which the order variance in Scenario A is easily obtained by taking expectations,

$$\sigma_o^2 = \sigma_\varepsilon^2 \left( \kappa^2 + 2\kappa\rho^{1+T_p} + \frac{\rho^{2(1+T_p)}}{1-\rho^2} \right) = \sigma_\varepsilon^2 \frac{1+\rho+2\rho^{2(T_p+2)}-2\rho^{T_p+2}(1+\rho)}{(1-\rho)^2(1+\rho)}. \quad (11.7)$$

In Scenario A, the forecast orders are solely based upon the forecasted demand. Thus, the order forecast error in Scenario A is

$$\begin{aligned} \delta_t &= \hat{d}_{t-j,t+T_p+1} - o_t \\ &= \rho^{T_p+1+j} d_{t-j} - \left( \rho^{T_p+1} + \kappa \right) \varepsilon_t - \sum_{n=1}^{\infty} \rho^{T_p+1+n} \varepsilon_{t-n} \\ &= \rho^{T_p+1+j} \sum_{n=j}^{\infty} \rho^{n-j} \varepsilon_{t-n} - \left( \rho^{T_p+1} + \kappa \right) \varepsilon_t - \sum_{n=1}^{\infty} \rho^{T_p+1+n} \varepsilon_{t-n} \\ &= \left( -\rho^{T_p+1} - \kappa \right) \varepsilon_t + \sum_{n=1}^{j-1} \left( -\rho^{T_p+1+n} \right) \varepsilon_{t-n}. \end{aligned} \quad (11.8)$$

Then,  $\Delta_A[j]$ , the variance of the  $j$  period ahead order forecast error for Scenario A becomes

$$\begin{aligned} \Delta_A[j] &= \sigma_\varepsilon^2 \frac{\left( \kappa + \rho^{T_p+1} \right)^2 (1-\rho^2) + \rho^{2(T_p+1)} (\rho^2 - \rho^{2j})}{1-\rho^2} \\ &= \sigma_\varepsilon^2 \left( \frac{\rho^{2(1+j+T_p)}}{(\rho-1)(1+\rho)} + \frac{1+\rho+2\rho^{2(2+T_p)}-2\rho^{2+T_p}(1+\rho)}{(\rho-1)^2(1+\rho)} \right), \end{aligned} \quad (11.9)$$

which is increasing in  $j$ . The nervousness of Scenario A over  $m$  periods is increasing in  $m$  as,

$$\begin{aligned} \Delta_A &= \sigma_\varepsilon^2 \sum_{j=1}^m \frac{\left( \kappa + \rho^{T_p+1} \right)^2 (1-\rho^2) + \rho^{2(T_p+1)} (\rho^2 - \rho^{2j})}{1-\rho^2} \\ &= \sigma_\varepsilon^2 \left( \frac{m(1-2\rho^{2+T_p})}{(\rho-1)^2} + \frac{\rho^{2(2+T_p)} (\rho^{2m} - 1 + 2m(1+\rho))}{(\rho^2-1)^2} \right). \end{aligned} \quad (11.10)$$

The difference between the order forecast errors in Scenario B is

$$\begin{aligned}
 \delta_t &= \hat{d}_{t-j,t+T_p+1} - o_t \\
 &= \sum_{n=j}^{\infty} \rho^{T_p+1+n} \varepsilon_{t-n} - \sum_{n=0}^{\infty} \left( \left( \frac{T_i-1}{T_i} \right)^n \left( \rho^{T_p+1} + \frac{\kappa}{T_i} \right) + \rho^{T_p+1} \left( \rho^n - \left( \frac{T_i-1}{T_i} \right)^n \right) \right) \varepsilon_{t-n} \\
 &= \sum_{n=0}^{j-1} \left( - \left( \frac{T_i-1}{T_i} \right)^n \left( \rho^{T_p+1} + \frac{\kappa}{T_i} \right) - \rho^{T_p+1} \left( \rho^n - \left( \frac{T_i-1}{T_i} \right)^n \right) \right) \varepsilon_{t-n} + \\
 &\quad \sum_{n=j}^{\infty} \left( \rho^{T_p+1+n} - \left( \frac{T_i-1}{T_i} \right)^n \left( \rho^{T_p+1} + \frac{\kappa}{T_i} \right) - \rho^{T_p+1} \left( \rho^n - \left( \frac{T_i-1}{T_i} \right)^n \right) \right) \varepsilon_{t-n}.
 \end{aligned} \tag{11.11}$$

The variance of the  $j$  period ahead order forecast error in Scenario B,  $\Delta_B[j]$ , is

$$\begin{aligned}
 \Delta_B[j] &= \sigma_{\varepsilon}^2 \left( \sum_{n=0}^{j-1} \left( \left( \frac{T_i-1}{T_i} \right)^n \left( \rho^{T_p+1} + \frac{\kappa}{T_i} \right) + \rho^{T_p+1} \left( \rho^n - \left( \frac{T_i-1}{T_i} \right)^n \right) \right)^2 + \right. \\
 &\quad \left. \sum_{n=j}^{\infty} \left( \rho^{T_p+1+n} - \left( \frac{T_i-1}{T_i} \right)^n \left( \rho^{T_p+1} + \frac{\kappa}{T_i} \right) - \rho^{T_p+1} \left( \rho^n - \left( \frac{T_i-1}{T_i} \right)^n \right) \right)^2 \right) \\
 &= \sigma_{\varepsilon}^2 \left( \frac{\kappa^2}{T_i^2 \left( 1 - \left( \frac{T_i-1}{T_i} \right)^2 \right)} + \frac{2\kappa\rho^{1+T_p} \left( 1 - \left( \frac{\rho(T_i-1)}{T_i} \right)^j \right)}{T_i \left( 1 - \left( \frac{\rho(T_i-1)}{T_i} \right) \right)} + \frac{\rho^{2(1+T_p)} (1 - \rho^{2j})}{1 - \rho^2} \right),
 \end{aligned} \tag{11.12}$$

and the nervousness of Scenario over  $m$  periods is

$$\begin{aligned}
 \Delta_B &= \sigma_{\varepsilon}^2 \sum_{j=1}^m \left( \sum_{n=0}^{j-1} \left( \left( \frac{T_i-1}{T_i} \right)^n \left( \rho^{T_p+1} + \frac{\kappa}{T_i} \right) + \rho^{T_p+1} \left( \rho^n - \left( \frac{T_i-1}{T_i} \right)^n \right) \right)^2 + \right. \\
 &\quad \left. \sum_{n=j}^{\infty} \left( \rho^{T_p+1+n} - \left( \frac{T_i-1}{T_i} \right)^n \left( \rho^{T_p+1} + \frac{\kappa}{T_i} \right) - \rho^{T_p+1} \left( \rho^n - \left( \frac{T_i-1}{T_i} \right)^n \right) \right)^2 \right) \\
 &= \sigma_{\varepsilon}^2 \left( \frac{m\kappa^2}{T_i^2 \left( 1 - \left( \frac{T_i-1}{T_i} \right)^2 \right)} + \frac{\rho^{2(1+T_p)} \left( m(1 - \rho^2) + \rho^2 (\rho^{2m} - 1) \right)}{(\rho^2 - 1)^2} + \right. \\
 &\quad \left. \frac{2\kappa\rho^{1+T_p} \left( m \left( 1 - \frac{\rho(T_i-1)}{T_i} \right) + \frac{\rho(T_i-1)}{T_i} \left( \left( \frac{T_i-1}{T_i} \rho \right)^m - 1 \right) \right)}{T_i \left( \frac{\rho(T_i-1)}{T_i} - 1 \right)^2} \right).
 \end{aligned} \tag{11.13}$$

For Scenario C, we must first rewrite the order information generated by our proportional rule,  $\hat{o}_{t,t+j}$  in (7.5) as

$$\begin{aligned} \hat{o}_{t,t+j} &= \frac{1}{T_i} \left( \frac{T_i-1}{T_i} \right)^j (dwip_t - (wip_t + ns_t)) + \hat{d}_{t,t+T_p+1+j} + \frac{1}{T_i} \left( \frac{T_i-1}{T_i} \right)^j tns \\ &= \left( \frac{T_i-1}{T_i} \right)^{j+1} o_{t-1} + \left( \hat{d}_{t,t+T_p+1+j} - \left( \frac{T_i-1}{T_i} \right)^j \hat{d}_{t-1,t+T_p} \right) + \\ &\quad \frac{1}{T_i} \left( \frac{T_i-1}{T_i} \right)^j (dwip_t - dwip_{t-1}) + \frac{1}{T_i} \left( \frac{T_i-1}{T_i} \right)^j d_t. \end{aligned} \tag{11.14}$$

Assuming  $tns = 0$ , substituting (7.10) and (11.2) into (11.14) yields,

$$\hat{o}_{t,t+j} = \left( \frac{T_i-1}{T_i} \right)^{j+1} o_{t-1} + \left( \rho^{T_p+1+j} + \frac{\kappa}{T_i} \left( \frac{T_i-1}{T_i} \right)^j \right) \varepsilon_t + \rho^{T_p+1} \left( \rho^{j+1} - \left( \frac{T_i-1}{T_i} \right)^{j+1} \right) d_{t-1}. \tag{11.15}$$

Both  $o_t$  and  $\hat{o}_{t-j,t}$  can be written as  $\phi o_{t-j-1} + \theta_0 \varepsilon_t + \theta_1 \varepsilon_{t-1} + \theta_2 \varepsilon_{t-2} + \dots$ , the form of a ARMA( $j-1, \infty$ ) process. The coefficients in  $\hat{o}_{t-j,t}$  and  $o_t$  have been summarized in Table 11.1. The coefficients  $\theta_i$  for  $i \geq j$  in  $\hat{o}_{t-j,t}$  and  $o_t$  are identical. Note that the order error can be inverted to a MA( $j-1$ ) process, therefore only  $\varepsilon_t$  from time  $t$  to  $t-j+1$  will have an influence on the performance of the forecasted order error. Therefore, the forecast error in Scenario C is

$$\delta_t = \sum_{n=0}^{j-1} \left( - \left( \frac{T_i-1}{T_i} \right)^n \left( \rho^{T_p+1} + \frac{\kappa}{T_i} \right) - \rho^{T_p+1} \left( \rho^n - \left( \frac{T_i-1}{T_i} \right)^n \right) \right) \varepsilon_{t-n}. \tag{11.16}$$

Coefficient	$\hat{o}_{t-j,t}$	$o_t$
$\phi$	$\left( \frac{T_i-1}{T_i} \right)^{j+1}$	$\left( \frac{T_i-1}{T_i} \right)^{j+1}$
$\theta_0$	0	$\rho^{T_p+1} + \frac{\kappa}{T_i}$
$\theta_1$	0	$\left( \frac{T_i-1}{T_i} \right) \left( \rho^{T_p+1} + \frac{\kappa}{T_i} \right) + \rho^{T_p+1} \left( \rho - \frac{T_i-1}{T_i} \right)$
$\theta_2$	0	$\left( \frac{T_i-1}{T_i} \right)^2 \left( \rho^{T_p+1} + \frac{\kappa}{T_i} \right) + \rho^{T_p+1} \left( \rho^2 - \left( \frac{T_i-1}{T_i} \right)^2 \right)$
$\theta_3$	0	$\left( \frac{T_i-1}{T_i} \right)^3 \left( \rho^{T_p+1} + \frac{\kappa}{T_i} \right) + \rho^{T_p+1} \left( \rho^3 - \left( \frac{T_i-1}{T_i} \right)^3 \right)$
$\theta_n$	0	$\left( \frac{T_i-1}{T_i} \right)^n \left( \rho^{T_p+1} + \frac{\kappa}{T_i} \right) + \rho^{T_p+1} \left( \rho^n - \left( \frac{T_i-1}{T_i} \right)^n \right)$
$\theta_j$	$\rho^{T_p+1+j} + \left( \frac{T_i-1}{T_i} \right)^j \frac{\kappa}{T_i}$	$\left( \frac{T_i-1}{T_i} \right)^j \left( \rho^{T_p+1} + \frac{\kappa}{T_i} \right) + \rho^{T_p+1} \left( \rho^j - \left( \frac{T_i-1}{T_i} \right)^j \right)$
$\theta_{j+1}$	$\rho^{T_p+1} \left( \rho^{j+1} - \left( \frac{T_i-1}{T_i} \right)^{j+1} \right)$	$\rho^{T_p+1} \left( \rho^{j+1} - \left( \frac{T_i-1}{T_i} \right)^{j+1} \right)$
$\theta_{j+2}$	$\rho^{T_p+1} \left( \rho^{j+1} - \left( \frac{T_i-1}{T_i} \right)^{j+1} \right) \rho$	$\rho^{T_p+1} \left( \rho^{j+1} - \left( \frac{T_i-1}{T_i} \right)^{j+1} \right) \rho$
$\theta_{j+3}$	$\rho^{T_p+1} \left( \rho^{j+1} - \left( \frac{T_i-1}{T_i} \right)^{j+1} \right) \rho^2$	$\rho^{T_p+1} \left( \rho^{j+1} - \left( \frac{T_i-1}{T_i} \right)^{j+1} \right) \rho^2$
$\vdots$		
$\theta_{j+n}$	$\rho^{T_p+1} \left( \rho^{j+1} - \left( \frac{T_i-1}{T_i} \right)^{j+1} \right) \rho^{n-1}$	$\rho^{T_p+1} \left( \rho^{j+1} - \left( \frac{T_i-1}{T_i} \right)^{j+1} \right) \rho^{n-1}$



Table 11.1 Coefficients in  $\hat{\delta}_{t-j,t}$

Then  $\Delta_C[j]$ , can be derived by taking the expectation of (11.16)

$$\begin{aligned} \Delta_C[j] &= \sigma_\varepsilon^2 \\ &= \sigma_\varepsilon^2 \sum_{n=0}^{j-1} \left( \left( \frac{T_i-1}{T_i} \right)^n \left( \rho^{T_p+1} + \frac{\kappa}{T_i} \right) + \rho^{T_p+1} \left( \rho^n - \left( \frac{T_i-1}{T_i} \right)^n \right) \right)^2 \\ &= \sigma_\varepsilon^2 \left( \frac{\left( \left( \frac{T_i-1}{T_i} \right)^{2j} - 1 \right) \kappa^2}{\left( \left( \frac{T_i-1}{T_i} \right)^2 - 1 \right) T_i^2} + \frac{\rho^{2+2T_p} (1 - \rho^{2j})}{1 - \rho^2} + \frac{2\kappa \rho^{1+T_p} \left( \left( \rho \left( \frac{T_i-1}{T_i} \right) \right)^j - 1 \right)}{T_i \left( \rho \left( \frac{T_i-1}{T_i} \right) - 1 \right)} \right), \end{aligned} \quad (11.17)$$

which is increasing in  $j$ . Finally, the performance of the future order stream generated through the proportional controller  $T_i$  can be measured by

$$\begin{aligned} \Delta_C &= \sigma_\varepsilon^2 \sum_{j=1}^m \sum_{n=0}^{j-1} \left( \left( \frac{T_i-1}{T_i} \right)^n \left( \rho^{T_p+1} + \frac{\kappa}{T_i} \right) + \rho^{T_p+1} \left( \rho^n - \left( \frac{T_i-1}{T_i} \right)^n \right) \right)^2 \\ &= \sigma_\varepsilon^2 \sum_{j=1}^m \left( \frac{\left( \left( \frac{T_i-1}{T_i} \right)^{2j} - 1 \right) \kappa^2}{\left( \left( \frac{T_i-1}{T_i} \right)^2 - 1 \right) T_i^2} + \frac{\rho^{2+2T_p} (1 - \rho^{2j})}{1 - \rho^2} + \frac{2\kappa \rho^{1+T_p} \left( \left( \rho \left( \frac{T_i-1}{T_i} \right) \right)^j - 1 \right)}{T_i \left( \rho \left( \frac{T_i-1}{T_i} \right) - 1 \right)} \right) \\ &= \sigma_\varepsilon^2 \left( \frac{\kappa^2 \left( \left( \frac{T_i-1}{T_i} \right)^{2m+2} - \left( \frac{T_i-1}{T_i} \right)^2 (m+1) + m \right)}{\left( \left( \frac{T_i-1}{T_i} \right)^2 - 1 \right)^2 T_i^2} + \frac{(\rho^2 (\rho^{2m} - 1) - m\rho^2 + m) \rho^{2T_p+2}}{(\rho^2 - 1)^2} + \right. \\ &\quad \left. \frac{2\kappa \rho^{T_p+1} \left( \frac{\rho(T_i-1)}{T_i} \left( \left( \frac{\rho(T_i-1)}{T_i} \right)^m - 1 \right) + m - \left( \frac{T_i-1}{T_i} \right) m\rho \right)}{T_i \left( \left( \frac{T_i-1}{T_i} \right) \rho - 1 \right)^2} \right). \end{aligned} \quad (11.18)$$

## 12. Appendix: The variance of the manufacturer's net stock

Combining (7.21) and (7.20), we have

$$ns_{t,2} = ns_{t-1,2} + \sum_{j=1}^{T_s+1} \left( \hat{o}_{t-T_s-1,t-T_s-1+j} - \hat{o}_{t-T_s-2,t-T_s-2+j} \right) + o_{t-T_s-1,1} - o_{t,1}. \quad (12.1)$$

By combining (11.4) and the information in Table 11.1, we may also obtain

$$\hat{o}_{t,t+j} = \sum_{n=0}^{\infty} \left( \rho^{T_p+1+j+n} + \frac{\kappa}{T_i} \left( \frac{T_i-1}{T_i} \right)^{j+n} \right) \varepsilon_{t-n}. \quad (12.2)$$

Using (12.2), we can find

$$\hat{o}_{t-T_s-1,t-T_s-1+j} - \hat{o}_{t-T_s-2,t-T_s-2+j} = \left( \left( \rho^{T_p+1+j} + \frac{\kappa}{T_i} \left( \frac{T_i-1}{T_i} \right)^j \right) \varepsilon_{t-T_s-1} + \sum_{n=1}^{\infty} \left( (\rho-1) \rho^{T_p+j+n} - \frac{\kappa}{T_i^2} \left( \frac{T_i-1}{T_i} \right)^{j-1+n} \right) \varepsilon_{t-T_s-1-n} \right). \quad (12.3)$$

Based upon (11.4), it is easy to calculate

$$o_{t-T_s-1,1} - o_{t,1} = \left( \sum_{n=0}^{T_s} \left( -\rho^{T_p+1+n} - \frac{\kappa}{T_i} \left( \frac{T_i-1}{T_i} \right)^n \right) \varepsilon_{t-n} + \sum_{n=0}^{\infty} \left( \frac{\kappa}{T_i} \left( \frac{T_i-1}{T_i} \right)^n \left( 1 - \left( \frac{T_i-1}{T_i} \right)^{T_s+1} \right) + (1 - \rho^{T_s+1}) \rho^{T_p+1+n} \right) \varepsilon_{t-T_s-1-n} \right). \quad (12.4)$$

Substituting (12.3) and (12.4) into (12.1), we can derive

$$ns_{t,2} = ns_{t-1,2} + \sum_{n=0}^{T_s} \left( -\rho^{T_p+1+n} - \frac{\kappa}{T_i} \left( \frac{T_i-1}{T_i} \right)^n \right) \varepsilon_{t-n} + \left( \kappa \left( 1 - \left( \frac{T_i-1}{T_i} \right)^{T_s+1} \right) + \rho^{T_p+1} \sum_{i=0}^{T_s} \rho^i \right) \varepsilon_{t-T_s-1}. \quad (12.5)$$

If we substitute (12.5) into itself recursively, we can see the net stock series is a MA process as

$$ns_{t,2,C} = \sum_{n=0}^{T_s} \sum_{i=0}^n \left( -\rho^{T_p+1+i} - \frac{\kappa}{T_i} \left( \frac{T_i-1}{T_i} \right)^i \right) \varepsilon_{t-n}, \quad (12.6)$$

and the variance of net stock level in the manufacturer for Scenario C is

$$\sigma_{ns_{2,C}}^2 = \sigma_{\varepsilon}^2 \sum_{n=0}^{T_s} \left( \sum_{i=0}^n \left( \rho^{T_p+1+i} + \frac{\kappa}{T_i} \left( \frac{T_i-1}{T_i} \right)^i \right) \right)^2. \quad (12.7)$$

Following the same procedure, we can transform the net stock series in Scenario B as

$$ns_{t,2,B} = \sum_{n=0}^{T_s} \sum_{i=0}^n \left( -\rho^{T_p+1+i} - \frac{\kappa}{T_i} \left( \frac{T_i-1}{T_i} \right)^i \right) \varepsilon_{t-n} + \sum_{n=0}^{\infty} \left( -\left( \frac{T_i-1}{T_i} \right)^{1+n} \left( 1 - \left( \frac{T_i-1}{T_i} \right)^{T_s+1} \right) \kappa \right) \varepsilon_{t-T_s-1-n}. \quad (12.8)$$

Then for Scenario B, the net stock variance in the manufacturer is

$$\sigma_{ns_{2,B}}^2 = \sigma_{\varepsilon}^2 \left( \sum_{n=0}^{T_s} \left( \sum_{i=0}^n \left( \rho^{T_p+1+i} + \frac{\kappa}{T_i} \left( \frac{T_i-1}{T_i} \right)^i \right) \right)^2 + \sum_{n=0}^{\infty} \left( \left( \frac{T_i-1}{T_i} \right)^{1+n} \left( 1 - \left( \frac{T_i-1}{T_i} \right)^{T_s+1} \right) \kappa \right)^2 \right). \quad (12.9)$$

It is clear to see that  $\sigma_{ns_{2,C}}^2 < \sigma_{ns_{2,B}}^2$ . The net stock variance for Scenario A can be easily

derived from (12.7) by setting  $T_i = 1$ ,

$$\sigma_{ns_{2,A}}^2 = \sigma_{\varepsilon}^2 \left( \frac{T_s(\rho-1) - 2\rho^{3+T_p+T_s}}{(\rho-1)^3} + \frac{\rho^2 \left( 1 + \rho^{T_p} \left( 2 + 2\rho - \rho^{2+T_p} + \rho^{2(2+T_s)+T_p} \right) \right) - 1}{(\rho-1)^3 (1+\rho)} \right). \quad (12.10)$$

### 13. Appendix: Proof to $T_i^{-1} < 1 - \rho$ enables $\sigma_o^2 < \sigma_d^2$ for $\rho > 0$ and $T_p \in \mathbb{N}_0$

From (7.26), we notice if  $T_i^{-1} = 1 - \rho$ , for any  $\rho$  value, the effect of  $T_p$  disappears, as (7.26) reduces to

$$\sigma_{o_i}^2 = \sigma_\varepsilon^2 (1 - \rho^2)^{-1}. \quad (13.1)$$

Comparing (13.1) to (7.27), it is easy to notice that  $\sigma_{o_i}^2 = \sigma_d^2$ , suggesting the bullwhip effect is avoided under this setting for any demand correlation  $\rho$  and all lead-times  $T_p$ .

When  $T_i^{-1} < 1 - \rho$  and  $0 < \rho < 1$ , it is easy to see from (7.26) that the retailer's order variance is *decreasing* in  $T_p$ . In this situation, the order variance when  $T_p = 0$ ,

$$\sigma_{o_i}^2 \Big|_{T_p=0} = \sigma_\varepsilon^2 \left( \frac{T_i (1 + \rho (3 - 2(1 - T_i(1 - \rho))\rho)) - \rho}{(2T_i - 1)(\rho + T_i(1 - \rho))(1 - \rho^2)} \right), \quad (13.2)$$

is a maximum value which is always less than the demand variance. These indicate that by setting  $T_i^{-1} < 1 - \rho$ , there is no bullwhip for any  $T_p$  for positive  $\rho$ . This is a sufficient condition.

When  $T_i^{-1} > 1 - \rho$  and  $0 < \rho < 1$ , the order variance is an *increasing* function in  $T_p$ , see (7.26). In the limit, as  $T_p$  approaches positive infinity, the order variance is given by

$$\sigma_{o_i}^2 \Big|_{T_p \rightarrow \infty} = \sigma_\varepsilon^2 / ((2T_i - 1)(1 - \rho)^2), \quad (13.3)$$

which is the worst case scenario. (13.3) is smaller than the demand variance (7.27) only when  $0 < T_i < 0.5$  for positive  $\rho$ . This suggests that  $\sigma_o^2 < \sigma_d^2$  does not necessarily require  $T_i^{-1} < 1 - \rho$ . Thus,  $T_i^{-1} < 1 - \rho$  is not a necessary condition.

Therefore,  $T_i^{-1} < 1 - \rho$  is only a sufficient but not necessary condition that  $\sigma_o^2 < \sigma_d^2$  for  $\rho > 0$  and  $T_p \in \mathbb{N}_0$ .

## 14. Appendix: Behaviour of the manufacturer's order variance in Scenario

### C

From (7.28), we see that both  $T_p$  and  $T_s$  might produce odd-even lead-time effects when  $\rho$  is negative.

Considering the AR(1) demand variance (7.27), we notice

$$\lim_{T_p \rightarrow \infty} \sigma_{o_2}^2 = \sigma_\varepsilon^2 \left( \frac{\left( 2 \left( \frac{T_i-1}{T_i} \right)^{4+2T_s} - 2 \left( \frac{T_i-1}{T_i} \right)^{2+T_s} \left( 1 + \frac{T_i-1}{T_i} \right) + 1 + \frac{T_i-1}{T_i} \right)}{\left( 1 + \frac{T_i-1}{T_i} \right) (1-\rho)^2} \right), \quad (14.1)$$

and

$$\lim_{\substack{T_p \rightarrow \infty \\ T_s \rightarrow \infty}} \sigma_{o_2}^2 = \frac{1+\rho}{1-\rho} \sigma_d^2. \quad (14.2)$$

When  $T_i^{-1} = 1-\rho$ , the impact of  $T_p$  will disappear as (7.28) reduces to

$$\sigma_{o_2}^2 = \sigma_\varepsilon^2 \left( \frac{1+\rho - 2\rho^{2+T_s} - 2\rho^{3+T_s} + 2\rho^{4+2T_s}}{(1-\rho)^2(1+\rho)} \right). \quad (14.3)$$

(14.3) is an increasing function of  $T_s$  and: is always greater than the variance of consumer demand for positively correlated demand; equals to the demand variance when  $\rho=0$  regardless of  $T_p$  and  $T_s$ ; oscillates around (14.2) for negative correlation but always converges to (14.2) as  $T_s$  increases.

If  $T_i^{-1} < 1-\rho$ , for i.i.d. demand, the effect of  $T_p$  will disappear. The manufacturer's order variance function is increasing in  $T_s$  and has a limit to  $\sigma_d^2$ . For  $\rho > 0$ ,  $\sigma_{o_2}^2$  is increasing in  $T_s$

and decreasing in  $T_p$ , but it is possible to be smaller than  $\sigma_d^2$  when there is a small  $T_s$  or a large  $T_i$ . For  $\rho < 0$ , the bullwhip behaviour is rather complex. It is possible, however, to see that the order variance is increasing in  $T_s$  and we can weaken the odd-even lead-time effect of  $T_p$  by setting  $T_i$  to a large value. Based upon (14.1) and (14.2), the bullwhip effect is also eliminated.

If  $T_i^{-1} > 1 - \rho$ , for  $\rho = 0$ ,  $T_s$  has an odd-even lead-time effect on the manufacturer's order variance which oscillates and converges to (14.2). For positive  $\rho$ , when  $1 \leq T_i < (1 - \rho)^{-1}$ , increasing either lead-time, the order variance will increase. Considering the knowledge of (14.1) the order variance is less than the demand variance, suggesting no bullwhip effect. When  $T_i < 1$  or  $\rho < 0$ , although the dynamics between  $\sigma_{o_2,C}^2$ ,  $T_p$ ,  $T_s$  and  $T_i$  is complex, sometimes it is possible to avoid generating the bullwhip effect.

In summary, it is possible to engineer the bullwhip avoidance behaviour by tuning the  $T_i$  value, no matter what the  $T_p$  value is. When  $T_s$  is significantly large, as shown in (14.2), the bullwhip at the manufacturer is solely determined by the end customer demand pattern.