

**A Waste Heat Recovery Strategy for
An Integrated Steelworks**

By

Christopher Lloyd Williams

Thesis submitted to the Cardiff University in fulfilment of the
requirements for the degree of Doctor of Philosophy.

School of Engineering

Cardiff University

December 2015

Summary

UK energy prices have doubled over the last decade, which has driven the UK Iron and Steel Industry to invest in energy efficient technologies. However, even with these relatively high prices the industry still finds it difficult to build a business case to justify waste heat recovery projects. The Steel Industry has large quantities of waste heat and there are technologies readily available for its capture, but often the issue has been finding a cost effective 'end use'. Individual schemes incorporating both capturing and an 'end use' for the waste heat often incur high capital costs with resulting long payback times. This thesis defines the development and modelling of a strategy and methodology for the utilisation of waste heat recovery in a UK based Steelworks. The methodology involves the utilisation of the existing steam distribution circuit to link the possible waste heat schemes together with a single 'end user' thus limiting the capital requirement for each subsequent project. The thesis defines the development of a numerical model that is initially verified through extensive comparison to actual plant data from a series of pre-defined operational scenarios. The model is used to predict the pressure and temperature effects on the steam distribution system as the waste heat recovery boilers from various areas of the case study steelworks are connected up to it.

The developed strategy stimulated significant capital investment for the CSSW and has generated over 100,000 MWh and is therefore saving over £7m and 50,000 tonnes of indirect CO₂ emissions per annum. The thesis discusses and recommends further research and modelling for low, medium and high grade waste heat as well as the potential of a partial de-centralisation of the steam system. The output of the thesis is referenced by the DECC as an example of waste heat recovery in UK industry.

Declaration

This work has not previously been accepted in substance for any degree and is not being concurrently submitted in candidature for any degree

Signed.....[candidate] Date.....

Statement 1

This thesis is being submitted in partial fulfilment of the requirements for the degree of Doctor of Philosophy.

Signed..... [Candidate] Date.....

Statement 2

This thesis is the result of my own independent work/investigation, except where otherwise stated. Other sources are acknowledged by explicit references.

Signed..... [Candidate] Date.....

Statement 3

I hereby give consent for my thesis, if accepted, to be available for photocopying and inter-library loan, and for the title and summary to be made available to outside organisations.

Signed..... [Candidate] Date.....

Acknowledgements

I would like to thank Mr Ben Burgraaf, Richard Charlton and Martyn Garrett for their assistance in completing this project. I would also like to thank Ms Lianne Deeming and Dr Mike Copeland for initially 'volunteering' me to participate in the overall project with Cardiff University.

I am very grateful to my supervisors Professor Anthony Griffiths and Tim O'Doherty for their continued help, support and guidance during this project.

Most of all I would like to thank my dear wife and three children for putting up with, what must have seemed like, endless weekends and evenings spent modelling

Thanks all!!

Table of Contents

1 Introduction.....	1
1.1 Thesis Context.....	1
1.2 Climate Change Policies.....	1
1.3 Climate Change and the Steel Industry.....	6
1.4 Energy Policies.....	10
1.5 Energy Flows in the Steel Industry.....	17
1.6 Energy Efficiency in the Steel Industry.....	19
1.7 Energy Use in the UK steel industry.....	22
1.8 Summary and Aim of this work.....	25
1.9 Structure of the Thesis.....	26
2 The steel Industry.....	28
2.1 Introduction.....	28
2.2 How to make steel.....	28
2.3 Consumption of Steel.....	30
2.4 The World Steel Industry.....	31
2.5 The European Steel Industry.....	33
2.6 The UK Steel Industry.....	36
2.7 The Case Study Steel Works (CSSW).....	42
2.8 Energy flows in the CSSW.....	44
2.9 Summary.....	47
3 Industrial Waste Heat Recovery.....	49
3.1 Introduction.....	49

3.2 UK Heat Supply.....	49
3.3 Waste Heat Recovery (WHR).....	53
3.4 Quantity.....	56
3.5 Technology.....	58
3.6 End Use.....	63
3.7 Barriers to WHR.....	64
3.8 Heat Recovery in the Steel Industry.....	66
3.9 Quantity.....	69
3.10 Technology.....	75
3.11 End Use.....	77
3.12 Waste Heat Recovery Opportunities in the CSSW.....	79
3.13 Summary.....	99
4 Steam Distribution.....	100
4.1 Introduction.....	100
4.2 Steam and Steam Distribution.....	100
4.3 Steam distribution circuit at the CSSW.....	104
4.4 Mass Balance analyses for the CSSW.....	109
4.5 Possible WHR boilers at the CSSW.....	115
4.6 Loss of electrical generation.....	116
4.7 BOS Plant WHR investigations.....	117
4.8 The proposed WHR strategy.....	129
4.9 Summary.....	131
5 Modelling the Steam Distribution Circuit.....	133

5.1 Introduction.....	133
5.2 The Software.....	134
5.3 Methodology.....	137
5.4 Construction of the Fluid Model.....	148
5.5 Validation of the Model with Plant Data.....	155
5.6 Summary.....	169
6 Results and Discussion.....	171
6.1 Introduction.....	171
6.2 Basic Oxygen Steelmaking (BOS Plant).....	173
6.3 Continuous Annealing CAPL line (CAPL).....	190
6.4 SinterPlant.....	196
6.5 Hot Strip Mill (HSM).....	200
6.6 Taking the Service Boilers Off-line.....	205
6.7 Summary.....	208
7 Overall Strategy.....	210
7.1 Introduction.....	210
7.2 Low Grade WHR opportunities.....	213
7.3 District Heating Internal.....	215
7.4 District Heating External.....	216
7.5 Steam System Optimisation.....	220
7.6 De-Centralisation of the steam system.....	220
8 Conclusions.....	224
8.1 Review of Thesis Aims.....	224

8.2 Conclusions.....	225
9 Recommendations and further work.....	227
10 References.....	228

List of Tables

Table 1: Example Steel Industry WHR Potentials (Energy 2014a).....	71
Table 2: Low Grade WHR Potentials (University).....	73
Table 3: Energy and Exergy Potentials (Patsos and Mullan 2011)	74
Table 4 : Case Study Works Production Capabilities (McKenna 2009a)	80
Table 5: Potential Benefits of DCQ	82
Table 6 Projected Benefits of BF Stove WHR	87
Table 7: Potential Benefits of HSM WHR	92
Table 8: Case Study Works WHR potential	96
Table 9: Comparison between actual and Modelled Data.....	143
Table 10: Schedule 40 pipe dimensions	151
Table 11 : The Scenarios	156
Table 12 : Development Phases of the Model.....	163
Table 13 : Parameters altered for Sensitivity analyses.....	167
Table 14: Scenarios utilised for modelling	177

Table of Figures

Figure 1 : OECD GHG Emissions Outlook(OECD 2013).....	3
Figure 2 Comparative CO ₂ Emissions per capita (Rivers 2008)	4
Figure 3 : EU Best Case Modelling (EC 2011)	5
Figure 4 Global Greenhouse Gas Emissions by Source (EPA 2014)	7
Figure 5 Percentage of Industrial Emissions per Industry type (IEA, 2007)	7
Figure 6 Worldwide Steel Production (Carbon Trust 2011)	8
Figure 7 Emissions per Steelmaking Process (Carbon Trust 2011)	9
Figure 8 : UK GHG Emissions (DECC 2013a).....	13
Figure 9 : UK Energy Intensity (DECC 2013a)	13
Figure 10: UK Energy Import Dependency (DECC 2013a)	14
Figure 11 : UK Industrial Fuel Prices (DECC 2013a)	15
Figure 12 : Electricity and Gas Price Trends (EEF 2014).....	16
Figure 13 Typical Energy Flows in an Integrated Steel Works (EC, 2013b).....	18
Figure 14: Energy Reduction Technologies (EC 2012)	20
Figure 15 : UK steel Industry Energy Intensity (EEF 2014).....	24
Figure 16 The Steelmaking Process (EEF 2014b).....	29
Figure 17 The Steel Manufacturing Process (EEF 2014c).....	30
Figure 18 : Worldwide Consumption of steel (WSA 2012).....	31
Figure 19 : World Steel Production (EEF 2014d)	33
Figure 20 World Steel Production by Country (WSA 2012)	34
Figure 21 European Steel Production per Country (EC 2012)	35
Figure 22 European Steel production per Country (ISSB 2014).....	36

Figure 23 UK Steel Production History (EEF 2014)	37
Figure 24 Steel Industry Raw Material Prices (EEF 2014).....	38
Figure 25 European Energy Prices (EEF 2014)	39
Figure 26 UK Steel and Aluminium Retail Price (EEF 2014)	39
Figure 27 Historical UK Steel Demand (EEF 2014)	40
Figure 28: CSSW Process Flow (Steel 2011).....	43
Figure 29 : Sankey Diagram for the CSSW	45
Figure 30: Case Study Sankey of Gas Flows	46
Figure 31 UK Split of Energy Consumers (DECC 2012b)	50
Figure 32 : UK Annual Energy Supply for Heating (DECC 2012b)	51
Figure 33 UK Split of Heating Demand (DECC 2012b)	52
Figure 34: Schematic of Blast Furnace regenerative stoves (AISI 2014)	60
Figure 35 Section Through a WHR Boiler (USDoE 2008).....	62
Figure 36: Mapping of Barrier Linkages (Manchester University 2010b)	66
Figure 37: Energy use for heat [heat load] and estimated recovery potentials for industrial sectors (McKenna 2009a)	67
Figure 38: Economic Potential of UK WHR potential (Energy 2014a)	68
Figure 39 Steel Industry Waste Heat Schematic (Newcastle University).....	69
Figure 40 High Grade Waste Heat Availability (Zhang et al. 2013b)	70
Figure 41: Global Exergy flow for Steel (Allwood and Cullen 2012).....	72
Figure 42 Example WHR Installations (GmbH 2014).....	76
Figure 43 Example Steam System Sankey Diagram (EC 2013b)	78
Figure 44: Example Dry Coke Quenching (Centre 2015).....	81

Figure 45: Sinter Bed and Cooler WHR (Liu et al. 2014)	83
Figure 46 Ijmuiden Sinter Plant WHR unit (Oschatz 2012)	84
Figure 47 Example WHR potential for Sinter Plants (EC 2013).....	85
Figure 48 Example Stoves Waste Heat Recovery Unit. (Paul Wurth 2015).....	86
Figure 49: Caster Process Flow (EC 2013b)	89
Figure 50 Conceptual Hot Slab WHR Unit SMS (Hemmling 2012).....	90
Figure 51 HSM WHR Example.....	92
Figure 52 Mass Balance of the Cold Mill and CAPL steam consumers.....	94
Figure 53 Predicted steam make from the CAPL WHR Boiler.....	95
Figure 54 Steam System layout for the CAPL and Cold Mill areas	95
Figure 55: Predicted Steam Make from the Case Study High Grade Waste Heat Sources	97
Figure 56: Example Steam Distribution System (EC 2013b).....	103
Figure 57: Steam Temperature Enthalpy Diagram (Sarco 2015)	104
Figure 58 Case Study Steel Works 11barg Steam Distribution System	106
Figure 59 : Section B Steam System Inspection Points	108
Figure 60: Thermal Image taken at point 12	108
Figure 61: Thermal image from Point 16.....	108
Figure 62 Examples of steam leaks from the distribution circuit	109
Figure 63 CSSW Steam Metering Schematic.....	110
Figure 64 Distributed Steam Consumption for the case study works.....	111
Figure 65 Power Plant 11bar steam consumption	111
Figure 66: High level consumption calculation for 11bar steam.....	112
Figure 67 Histogram of high level 11bar metered consumption	113

Figure 68 Pie Chart of 11bar steam consumers by type of use	114
Figure 69 Case Study Works Steam System Schematic	115
Figure 70 Potential Waste Heat Recovery Bridging Graph	116
Figure 71 Case Study Works Steam Control Philosophy	117
Figure 72 Case Study Works BOS Plant Photo.....	118
Figure 73 BOS Plant Off-Gas Ducting Cooling	119
Figure 74 Modelled electrical generation from BOS WHR boiler.	122
Figure 75 Modelled steam generation from the BOS WHR boiler	122
Figure 76 Modelled steam export from the BOS WHR boiler with accumulators.....	123
Figure 77 Modelled electrical generation form BOS WHR boiler	125
Figure 78 Proposed Steam Control Philosophy	127
Figure 79 Potential Steam Generation from WHR Projects.....	128
Figure 80 Case Study Works Bridge to Electrical Self sufficiency	129
Figure 81: The AS-IS	130
Figure 82 The Proposed Strategy for WHR Utilisation	130
Figure 83: Model development procedural flow chart.....	134
Figure 84 Friction Factors for actual Re for 16” pipe at 320°C	140
Figure 85: 16” New pipe vs Old Pipe comparison 200m 16” NB pipework	141
Figure 86 Software to manual calculation error	143
Figure 87 Schematic of Case Study Steel Works Steam System	149
Figure 88 : Fluidflow3 Pipe Data Pallet.....	150
Figure 89 Screen Print of the Fluidflow3 Model.....	153
Figure 90 Power Plant area of the 11bar steam system	154

Figure 91: Data Analysis Flow Chart.....	158
Figure 92 Bell curve for actual Power Plant pressures for Scenario 1	158
Figure 93 Maximum Standard Deviation per scenario	159
Figure 94 Variability of Plant Data.....	160
Figure 95: Example of data analysis for steam system	161
Figure 96 Development Sequence of the model.....	162
Figure 97 Pressure Errors by model Phase.....	164
Figure 98: Temperature errors by Model Phase	165
Figure 99 Development Phases of the Fluidflow Model.....	166
Figure 100: Percentage Error by Scenario	167
Figure 101 : Sensitivity Analysis.....	168
Figure 102: Steelmaking Process and WHR potential works areas.....	172
Figure 103: 11bar steam distribution system.....	173
Figure 104: BOS Plant Evaporative Cooling system. Source(Kasalo 2010)	174
Figure 105: Schematic of the 11barg steam distribution circuit	175
Figure 106: Fluidflow3 model of the 11barg steam distribution circuit	176
Figure 107: Predicted Maximum System Pressures	178
Figure 108: Predicted Pressures for individual model nodes	179
Figure 109: Predicted Pressure Gain by Works Area	180
Figure 110 Predicted Temperature Gain by Works Area.....	181
Figure 111 Steam Export from the South End of the works	182
Figure 112 Steam Export from the South End of the Works including BOS WHR boiler.....	182
Figure 113 Representation of the balance of the steam system.....	183

Figure 114 Schematic showing zero flow condition.....	184
Figure 115 Steam Temperature per Scenario	185
Figure 116 Modelling of the South West Corner of the steam system	186
Figure 117 Scenario 10 Service Boiler export flow vs Coke Ovens steam temperature	187
Figure 118 Top Bend of the off-gas system.	189
Figure 119: Steam Accumulators, superheater and the new TA in Powerplant	189
Figure 120: Positioning of new BOS Plant equipment and new mimic screen.....	190
Figure 121: Fluidflow3 Model adaptations	192
Figure 122 Pressure Gain from adding the CAPL WHR Boiler	192
Figure 123 Pressure gain by works area by adding the CAPL WHR Boiler	193
Figure 124 Modelled maximum system pressures by adding the CAPL WHR boiler	193
Figure 125 Predicted temperature effect of adding the CAPL WHR boiler	194
Figure 126 Local effect on the Mass balance by adding the CAPL WHR boiler	195
Figure 127: Zoom in on the North East Corner of the Model	196
Figure 128: Predicted Maximum Pressure per Scenario	197
Figure 129 Pressure Gain by Works Area.....	197
Figure 130: The relationship between distribution system pressures and Service Boiler outputs for Scenario 2.....	198
Figure 131 Steam Generation from WHR Boilers.....	199
Figure 132: Steam Import to South End when Service Boilers Off	200
Figure 133: Predicted Pressures per Scenario	201
Figure 134: Steam temperature per scenario	202
Figure 135: South End Import / Export.....	203

Figure 136 Scenario 10 Coke Ovens Temperature vs Service Boiler output	204
Figure 137 Scenario 10 Maximum system pressure vs Service Boiler Output	204
Figure 138 Steam temperatures and Pressures per scenario	206
Figure 139: System Pressure with the addition of WHR boilers	207
Figure 140 Schematic of the WHR projects	211
Figure 141 Extract from DECC ‘The Future of Heating’	212
Figure 142: Diagrammatic Steam and Heat Recovery Sankey Diagram	213
Figure 143: Steam Consumers	215
Figure 144: District Heating Example	217
Figure 145: Example Heat Recovery from Sinter Cooler	217
Figure 146 District Heating Proposition (NPTCBC 2013)	218
Figure 147 District Heating Questionnaire (Manchester 2010)	219
Figure 148: Partial De-Centralisation	222
Figure 149: Partial De-centralisation Modelling results	222

List of Abbreviations

ACEEE	American Council for an Energy Efficient Economy
Barg	Gauge pressure in bar
BAT	Best Available Technologies
BF	Blast Furnace
BFG	Blast Furnace Gas
BOS	Basic Oxygen Steelmaking
BOSG	Basic Oxygen Steelmaking Gas
BREF	Best Practice Reference Document
CAPL	Continuous Annealing Process Line
CCP	Climate Change Program
CCS	Carbon Capture and Storage
CDM	Clean Development Mechanism
CEPS	Centre for European Policy Studies
CHP	Combined Heat and Power
CHRIS	Centralised Heat Recovery Investment Strategy
CO	Coke Ovens
CO ₂	Carbon Dioxide
COG	Coke Oven Gas
ConCast	Continuous Casting
COP	Coefficient of Performance
COP	Conference of the Parties
CRC	Carbon Reduction Commitment
CRP	Cold Rolled Products

CSSW	Case Study Steelworks
DCQ	Dry Coke Quenching
DECC	Department of Energy and Climate Change
DEFRA	Department Environment, Food, and Rural Affairs
DETR	Department of Environmental Transport and the Regions
DRI	Direct Reduced Iron
DTi	Department of Transport and Industry
EA	Environmental Agency
EC	European Commission
ECA	Enhanced Capital Allowance
ECCP	European Climate Change Program
EEF	Engineers Employers Federation
EPA	Environment Protection Agency
EPSRC	Engineering and Physical Science Research Council
EU	European Union
EUETS	European Union Emissions Trading Scheme
Eurofer	European Steel Association
GHG	Green House Gas Emissions
HSM	Hot Strip Mill
IEA	International Energy Association
IFC	International Finance Corporation
IIP	Institute for Productivity
IISI	International Iron and Steel Institute
IPCC	Intergovernmental Panel on Climate Change
ISSB	International Steel Statistics Bureau

JI	Joint Implementation
KP	Kyoto Protocol
LISP	Low Impact Steel Project
MTPA	Million Tonnes per Annum
MWe	Mega Watts electric
MWh	Mega Watt hour
MWth	Mega Watts thermal
NE	North End
NPTCBC	Neath Port Talbot County Borough Council
OAPEC	Organisation of Arab Petroleum Exporting Countries
OECD	Organisation for Economic Co-operation and Development
ORC	Organic Rankin Cycle
PI	Plant Information system
RHI	Renewable Heat Incentive
SB	Service Boilers
SE	South End
SEC	Specific Energy Consumption
SETPlan	Strategic Energy Technology Plan
SOACT	State of the art Clean Technologies
SP	Sinter Plant
TA	Turbine Alternators
tph	Tonnes per Hour
UK	United Kingdom
UK	United Kingdom
UKAS	United Kingdom Accreditation Service

ULCOS	Ultra Low Carbon dioxide Steelmaking
UN	United Nations
UNFCCC	United Nations Framework Convention on Climate Change
USA	United States of America
USDoE	United States Department of Energy
WEC	World Energy Council
WHR	Waste Heat Recovery
WSA	World Steel Association

Nomenclature

<u>Symbols</u>	<u>Description</u>	<u>Units</u>
Q	Heat Content	Joules
V	Flow Rate	m ³ /hr
P	Density	kg/m ³
C _p	Specific Heat Capacity	J/kgK
Dt	Temperature Difference	K
E	Exergy	J
dH	Change in Enthalpy	J/Kg
dS	Change in Entropy	J/K
T _o	Absolute Temperature	K
Re	Reynolds Number	
M	Dynamic Viscosity	kg/m.s
ν	Kinematic viscosity	m ² /s
D	Diameter	m
Q _v	Volumetric Flow Rate	m ³ /s
A	Cross Sectional Area	m ²
f	Darcy Friction Factor	
h	Head Loss	m
V	Mean Flow Velocity	m/s
G	Gravity	m/s ²
R	Radius	m
K	Coefficient of thermal conductivity	W/m ² K
ε	Emissivity	
Σ	Stephan-Boltzmann constant	J/s ²
W _w	Pipe Wall Thickness	m
H _i	Inside Film Coefficient of heat transfer	W/m ² K ⁴

1. Introduction

1.1. Thesis Context

Today the United Kingdom's [UK's] steel industry is under many pressures, two of which are closely interconnected and their origins both began in the early nineteen seventies. The first is the United Nation's Earth Summit in 1972 that kick started the global 'Climate Change' efforts (UN 1972) and the effects of the 'oil crisis' in 1973 initiated the requirement for global energy strategies (IEA 1994). Global policies on 'Climate Change' and 'sustainable energy sources' are real issues for global sustainability and both have massive ramifications for the future of the steel industry. This chapter introduces the origins of Climate Change and sustainable energy policies and thus defines the roots of the current requirement to improve energy efficiency in the UK Steel Industry.

1.2. Climate Change Policies

The 1972 United Nations Stockholm Conference on the Human Environment, attended by 113 countries, was seen by many as far sighted and radical. However, few delegates grasped the sweeping implications of its principles. Most importantly it opened up debate, realization and worldwide awareness of the environment. In current times it's hard to imagine a world without the 'Environment' being a central agenda for Governments, Businesses, Universities and Schools. Before 1972 there were no Ministers of the Environment, no Environmental Departments, no Environmental reports, no Environmental correspondents, no Environmental awareness campaigns, no Environmental legislation, no Environmental lessons at schools and Universities etc. The Stockholm conference changed all that forever (U.N. 1972). The Nobel Prize winning Intergovernmental Panel on Climate Change [IPCC] was then established in

1988. The IPCCs report in 1990 pulled together key information and in 1992 led to the Rio de Janeiro Earth Summit which established the United Nations Framework Convention on Climate Change [UNFCCC] (UN 1992), the key international treaty to reduce global warming and cope with the consequences of climate change. The first Conference of the Parties [COP 1] took place in Berlin to outline specific targets on emissions (UN 1995). Then in 1997 the Kyoto conference developed the Kyoto Protocol [KP], which commits industrialised countries to stabilise Green House Gas [GHG] emissions (nrg4SD 2011) The Kyoto mechanisms are the International Emissions Trading [IET], Clean Development Mechanism [CDM] and the Joint Implementation [JI] (nrg4SD 2011). These mechanisms stimulated green investment and helped parties meet their emission targets in a cost-effective way. Under the KP, countries actual emissions have to be monitored and precise records of the trades carried out. As shown in Figure 1 the Organisation for Economic Co-operation and Development [OECD] modelled outlook for global Green House Gas [GHG] emissions. The figure is an outlook to 2050 and shows the predicted GHG emissions under two scenarios namely 'Business as usual', that is, the 'do nothing' option and then with some corrective measures applied, called the 'GHG Stabilisation Policy'. The trend shows a 60% increase in GHG emissions by 2050 if the world carries on as 'Business as usual'.

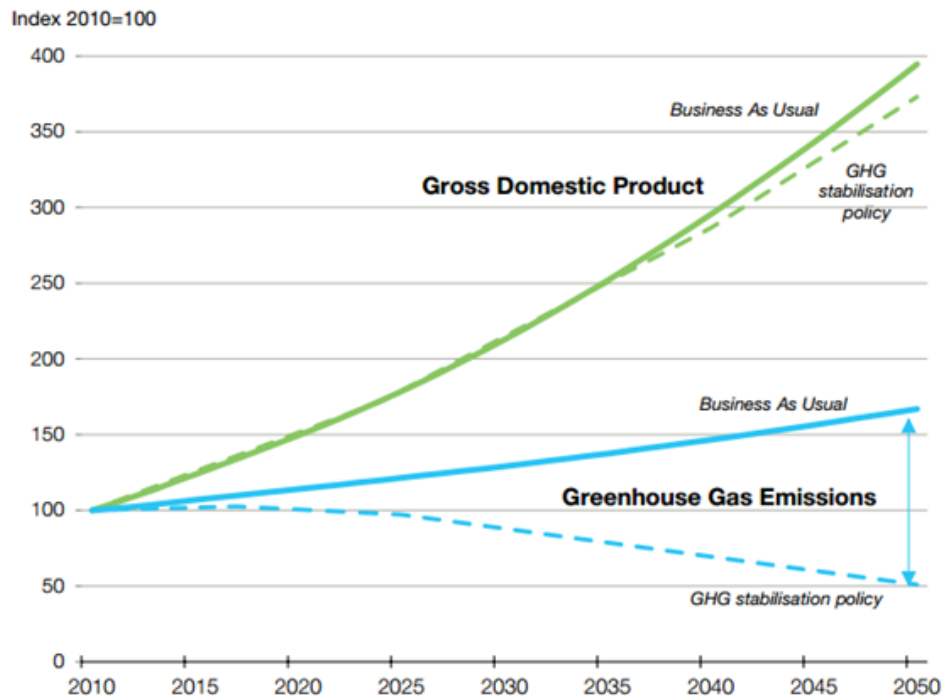

Figure 1 : OECD GHG Emissions Outlook(OECD 2013)

Figure 2 also graphically demonstrates, by the size of the inflated balloon, the relative emissions of CO₂ per capita for the year 2008. If one takes China as an example, according to the United Nations [UN], in 2011 China had a population of around 1.3billion compared to the USA 0.3billion (UN 2012). As China develops and becomes more ‘Western ‘, it would seem sensible to deduce that each capita of China would increase their CO₂ emission to the comparable level of the USA. Figure 2 clearly and graphically demonstrates the difference in emissions per capita between the Developed world and the developing world including China, India and Mexico. In effect the figure illustrates the relative size of emissions per capita, represented by the size of the balloon, thus enabling an understanding of the huge impact that the development of India, China and Mexico will have on GHG emissions in the world. It is therefore clear that with the world developing the ‘business as usual’ option would hugely increase GHG emissions and present catastrophic effects on the environment.

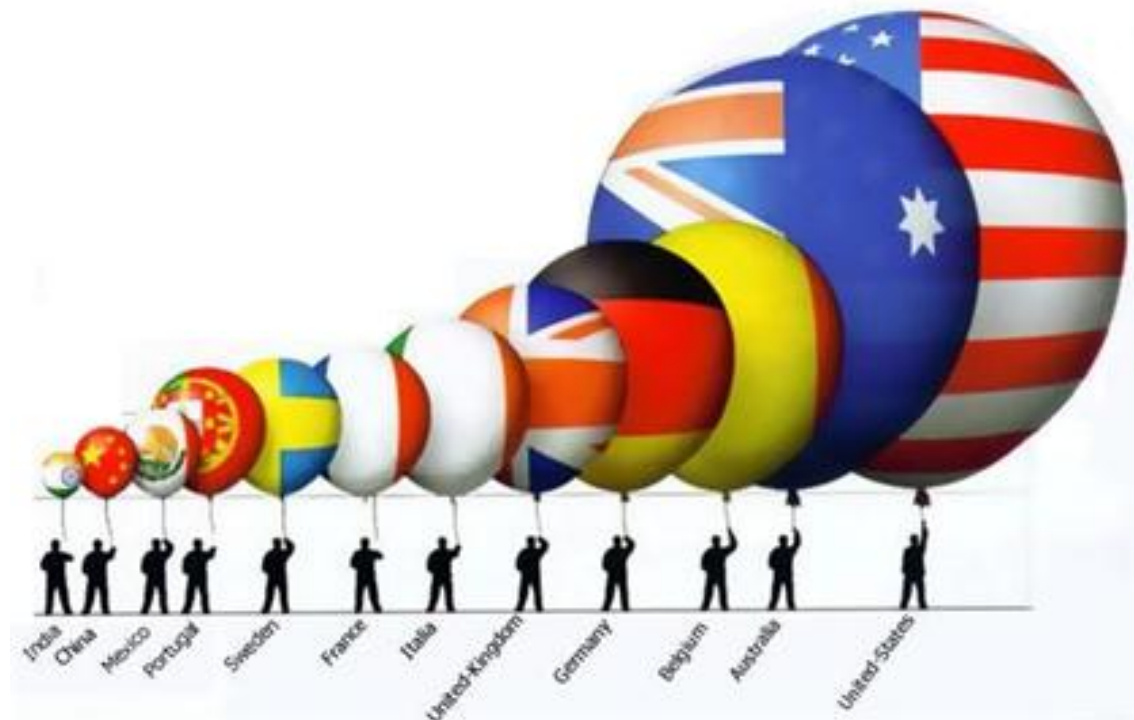

Figure 2 Comparative CO₂ Emissions per capita (Rivers 2008)

In June 2000, Europe attempted to implement all the elements of the KP, the European Commission [EC] launched the European Climate Change Programme [ECCP] (Rusche 2010). Its most significant contribution has been the launching, in 2005, of the world's first and largest GHG emissions trading scheme, the 'European Union [EU] Emission Trading Scheme' [EUETS]. In March 2007, the EU went onto endorse an integrated approach to climate and energy policy. The intentions were to combat climate change and increase the EU's energy security, while strengthening its competitiveness. The EU committed to cutting its GHG emissions by 20%, below 1990 levels, by 2020, known as the '20 20 target' (EC 2014). In 2008, the EU 'Strategic Energy Technology Plan' [SETPlan] was adopted as the technology pillar of the EU's climate change and energy (EC 2010). In February 2011, the EU endorsed objectives to reduce emissions by 80-90%, below 1990 levels, by 2050 and has published a roadmap for building a low carbon economy that will need to be followed by the EU and other developed countries (EC 2011b). Figure 3 shows the output of an exercise presented in

the Hague in 2011 (EC 2011) The exercise was to model current policy vs. a ‘best case scenario’ which assumes adoption of all currently available technologies and the required behavioural changes are made. It maps out, what it defines as, a cost efficient reduction in GHG emissions of 80% by 2050. From the figure it’s clear to see the relative reduction expected to be achieved by European industry. In fact the model defines an industrial sector milestone of an 83% to 87% reduction between 2010 and 2050. The exercise states that ‘energy efficiency is the single most important contribution particularly up to 2020’.

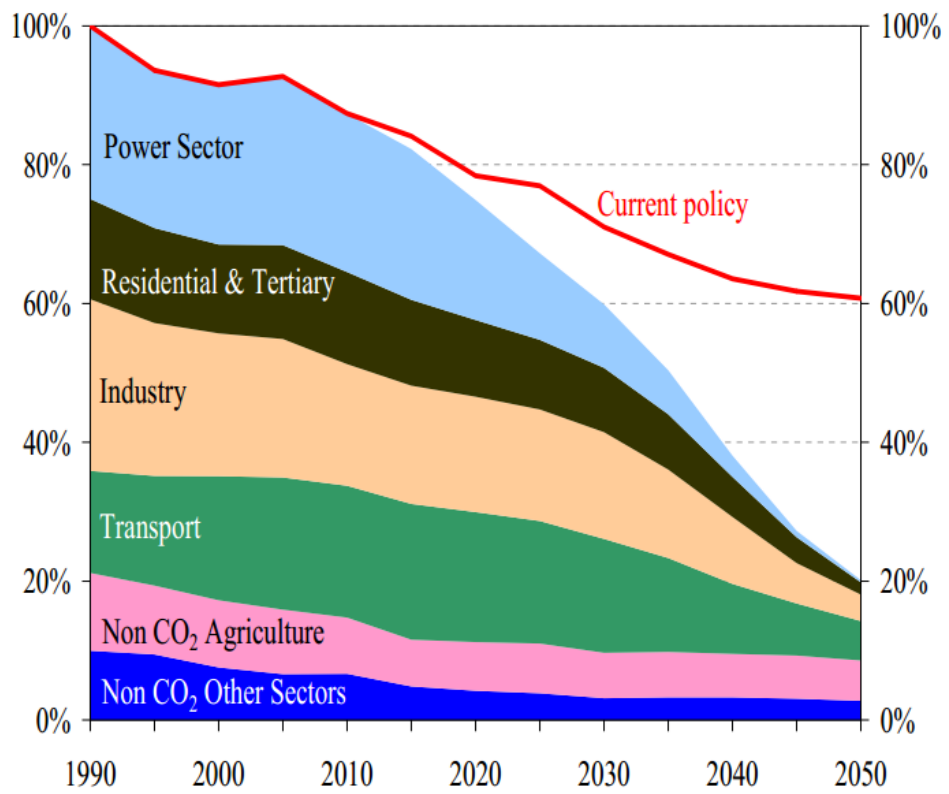

Figure 3 : EU Best Case Modelling (EC 2011)

In March 2013 the EU launched the GREEN PAPER ‘A 2030 framework for climate and energy policies’(EC 2013a). The 2030 targets are a measured stepping stones to the 2050 goals.

The UK's response was to launch the UK Climate Change Program [CCP] in November 2000 (DETR 2000). The aims of the program were not only to cut GHG emissions by 12.5%, from 1990 levels, in the period 2008 to 2012 [KP commitment], but to go beyond this target by cutting carbon dioxide emissions by 20% from 1990 levels by 2010.

On 26th November 2008, the UK 'Climate Change Act' became law putting in place a framework to achieve a mandatory 80% cut in carbon emissions by 2050, compared to 1990 levels, and also setting an intermediate target of a 34% reduction by 2020 (GOV, 2008). The Act's main drivers have been the Renewables Obligation scheme, Housing and Community Grants, Carbon Reduction Commitment [CRC] Energy Efficiency Scheme, the Green Deal and Electricity Market Reform. In 2010 the Government published 2050 Pathways Analysis (GOV 2010), which considered in detail the changes the UK would have to make in order to reduce greenhouse gas emissions by at least 80% by 2050. Then the 'UK Carbon Plan'(GOV 2011) was launched in 2011 with several main objectives including reducing emissions from business and industry. It stipulates an overall reduction of 70% in GHG emissions by UK industry. It details that industrial energy intensity could be cut by 40% through the adoption of further energy efficiency technologies.

1.3. Climate Change and the Steel Industry

As seen in Figure 4 around 19% of the Worlds GHG emissions are attributable to Industry.

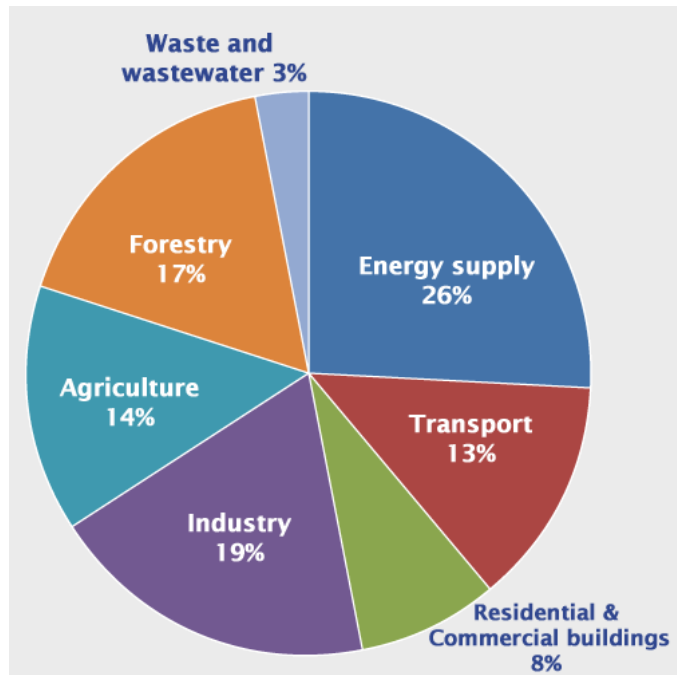

Figure 4 Global Greenhouse Gas Emissions by Source (EPA 2014)

Figure 5 then goes on to demonstrate that about 27% of the emissions from global Industry is attributable to the Iron and Steel Industry.

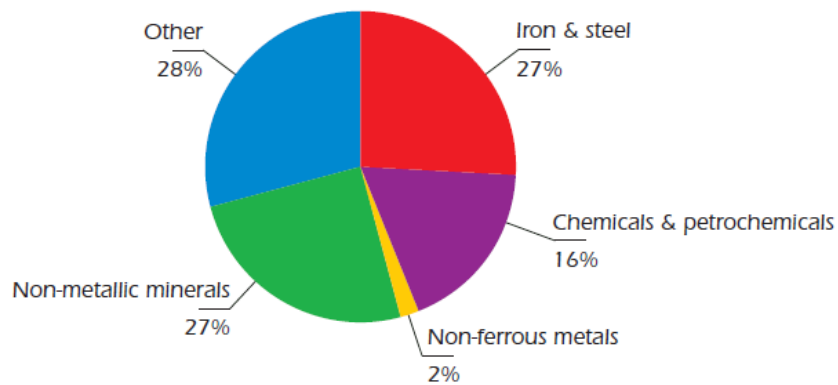
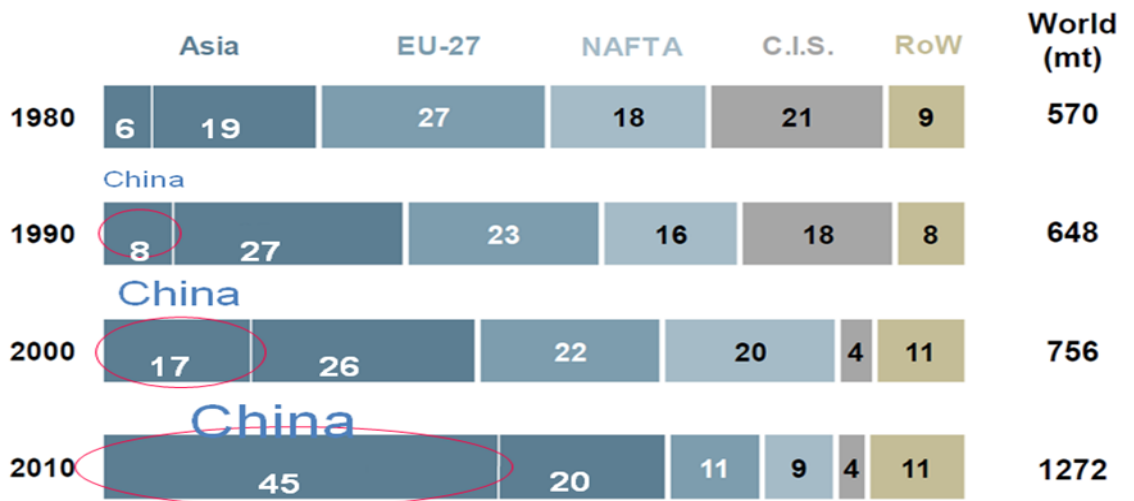

Figure 5 Percentage of Industrial Emissions per Industry type (IEA, 2007)

According to the World Steel Association [WSA] global steel production more than doubled between 1985 and 2010 (WSA 2013b). As shown in figure 6 over 1.3 billion tons of steel are now manufactured and used every year with 45% now produced in

China. The effect of the modernisation of China can be clearly seen in Figure 6. China's steel production has increased from 8MTPA [Million Tonnes per Annum] to 45 MTPA between 1990 and 2010. China now consumes 33% of the world's steel and its demand has been growing by 10% per year (Carbon Trust 2011) steel. China is obviously having a massive impact on global resources and GHG emissions. Strong growth will also accelerate in developing areas such as Latin America, Asia, Africa and the Indian sub-continent. Steel will be vital in raising the material and social welfare where more than 60% of steel consumption will be used to create new infrastructure(WSA 2012).



Source:Worldsteel oct 2010

Figure 6 Worldwide Steel Production (Carbon Trust 2011)

As shown in Figure 7, on average, 2.3 tonnes of CO₂ are emitted for every tonne of steel produced which is due to the energy intensity of steel production and its reliance on coal as the main energy source (Carbon Trust 2011). As shown in Figure 7, iron making in the Blast Furnace is responsible for ninety percent of steel industry emissions. The BF route is used for about 65% of all steel making (Carbon Trust 2011). Developing nations do not have the availability of scrap and are therefore forced to produce virgin iron using Blast Furnaces. For example, the Chinese steel industry mainly uses the BF

method but more developed nations have employed recycling of steel for decades and so there is a ready availability of scrap.(IEA 2007).

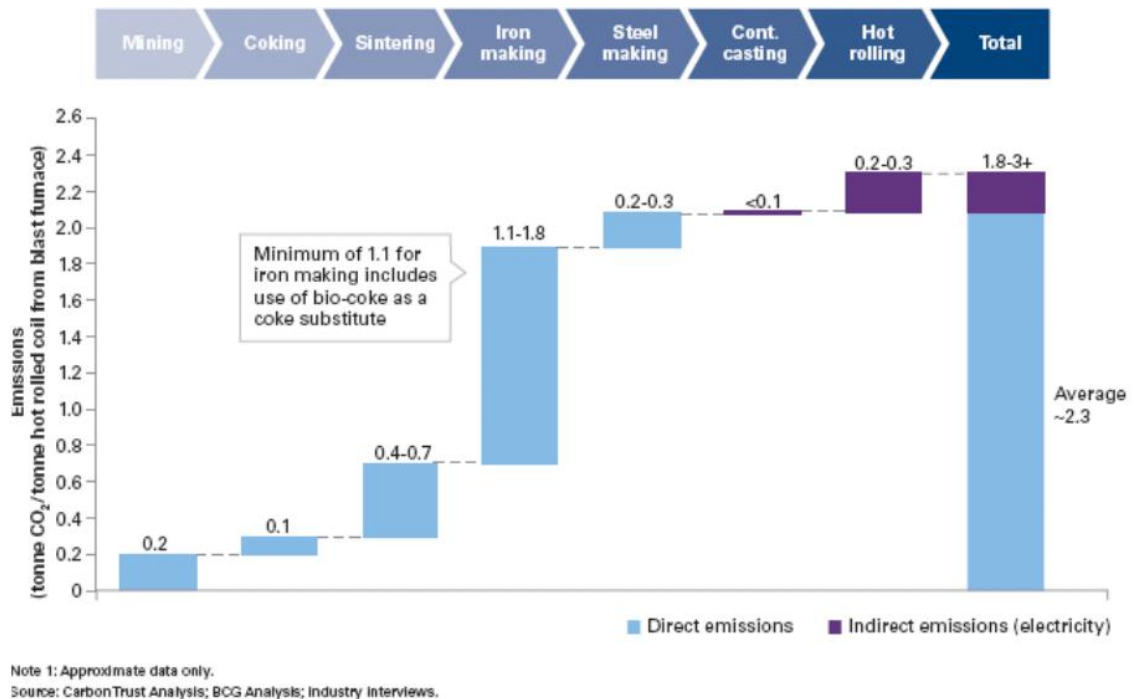

Figure 7 Emissions per Steelmaking Process (Carbon Trust 2011)

There are a number of technologies and measures available to reduce direct and process CO₂ emissions ,IEA-COAL (IEA-COAL 2012), from the different iron and steel making processes that involve:

- minimising energy consumption and improving the energy efficiency of the process;
- changing to a fuel and/or reducing agent with a lower CO₂ emission factor;
- capturing the CO₂ and storing it underground.

As detailed in the BREF (EC 2013b) and the Low Impact Steel Project [formerly ULCOS] website (LISP 2014), the main European project was ‘ULCOS’ which stands for ultra-low carbon dioxide [CO₂] steelmaking. It was a consortium of 48 European

companies and organisations from 15 European countries that have launched a cooperative R&D initiative to enable a drastic reduction in carbon dioxide [CO₂] emissions from steel production. The consortium consisted of all major EU steel companies, energy and engineering partners, research institutes and universities and is supported by the European Commission. The aim of the ULCOS project was to reduce CO₂ emissions with the most advanced techniques by at least 50 percent. The total budget of the project was EUR 47 million [2004 – 2009]. The project was targeted to run beyond 2015 with some full size implementation in industrial production lines but with the realization of the potential costs and the economic downturn the project has been shelved.

The EC document ‘Prospective Scenarios on Energy Efficiency and CO₂ Emissions in the EU Iron & Steel Industry’ (EC 2012) details R&D innovative projects , including Carbon Capture and Storage [CCS], and projects completion timescales for pilot project between 2020 – 2040.

Therefore most CO₂ reduction initiatives are long term Capital intensive options for the industry thus focusing on smaller scale energy saving techniques are thus important for the shorter and medium term CO₂ reduction plans for the industry(EC 2012).

1.4. Energy Policies

The 1973 ‘oil crisis’ was in effect a sudden price hike as a result of a retaliatory embargo by the Organization of Arab Petroleum Exporting Countries [OAPEC] on the United States of America [USA], United Kingdom [UK], Canada, Japan and the Netherlands. This crisis led to the realisation that worldwide coordination was required and so in 1973 the International Energy Association [IEA] was established within the framework of the Organisation for Economic Co-operation and Development [OECD] (IEA 2014). The World Energy Council [WEC], originally formed in 1923 as a

gathering of energy industry experts, then after the second world oil crisis in 1979, caused by the Iranian revolution, started to develop sustainability targets when its Conservation Commission published the report 'World Energy: Looking ahead to 2020'(Trotman 1984). Then following the oil price collapse and the world energy crisis in 1986, WEC published another landmark report 'Global Energy Perspectives 2000-2020' in 1989 (WEC 1989). This report was an important consensus based on two global energy scenarios, one regarded as moderate and the other as conservative . The report gained worldwide attention and was used by many policymakers and decision-makers as they considered plans for the future.

Further analyses and publications have been issued over the years with the emphasis moving more and more to sustainability. 'World Energy Trilemma 2012: Time to get real – the case for sustainable energy policy' (WEC 2012). 'World Energy Scenarios: Global Transport Scenarios 2050' (WEC 2011) and 'World Energy Issues Monitor 2014' (WEC 2014a) which was show cased at the seminar "Regional and Global Energy Panorama", February, Columbia, 2013 (WEC 2014b). Special emphasis was placed on the important role of energy efficiency for business. As defined earlier in the chapter, European and UK Climate Change Policies are looking to industry to improve energy efficiency by employing technologies not yet fully deployed. Therefore both Climate change and Energy policies are looking at industry to reduce its energy intensity and so the focus on industrial energy efficiency will only increase.

As far as the UK is concerned, the publication 'UK Energy Policy 1980-2010 A history and lessons to be learnt' (Peter and Jim 2012), describes the lack of development of the UK Energy Strategy. The political decisions starting in the 1980's around the coal industry, the type of nuclear reactor, the 'dash for gas', Climate change, lack of decision making led to the UK becoming a net importer of energy in 2004(DECC 2013a).

The Department of Trade and Industry [Dti] published the white paper 'Meeting the Energy Challenge' in 2007 (DTi 2007) was seen as being the start of an Energy plan for the UK. The policy was very market led with little true direction from the government. Prolonged decisions and policy on renewable carbon electricity then caused confusion, concern and lack of investment in the UK (Peter and Jim 2012). In 2008 the Department of Energy and Climate Change [DECC] was formed along with the Climate Change Act. The economic downturn then started to effect policies and, worried about increasing public debt, the government restricted the activities of the Green Bank and 'feed in tariffs'.

The White paper issued in 2011 'Planning our electric future: a White Paper for secure, affordable and low-carbon electricity, (DECC 2011), with a forward by the Secretary of State *"Since the market was privatised in the 1980s the system has worked: delivering secure and affordable electricity for the UK. But it cannot meet the challenges of the future. Around a quarter of our existing capacity – mainly coal and nuclear power stations – will close in the next decade. Keeping the lights on will mean raising a record amount of investment. However, the current market arrangements will not deliver investment at the scale and the pace that we need."* So some recognition that leaving the country to market led decisions – has not worked. It then goes on to define the position as an *"unprecedented challenge"* and warns of the risk of 'blackouts' which caused industry some alarm!

The annual Energy Brief (DECC 2013a) published by DECC clearly demonstrates the advantages and disadvantages of the UK energy position. Figure 8 shows the declining GHG emissions between 1990 and 2012. The figure indicates around a 25% reduction over the 22 years and also shows that the country more than met the Kyoto Protocol target.

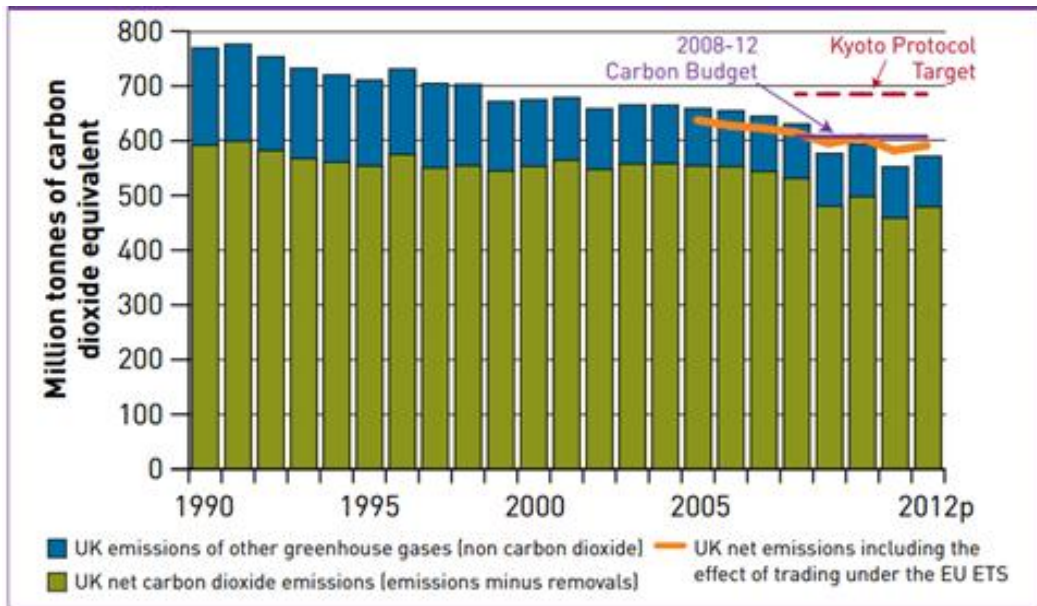

Figure 8 : UK GHG Emissions (DECC 2013a)

The declining trend for the industrial sector of Figure 9 also shows a successful story by demonstrating how much the country’s industry has reduced its energy intensity. The figure shows an industrial energy intensity reduction of just short of 60%. Indicating a successful long term drive in energy efficiency, albeit, a flattening trend over the last decade.

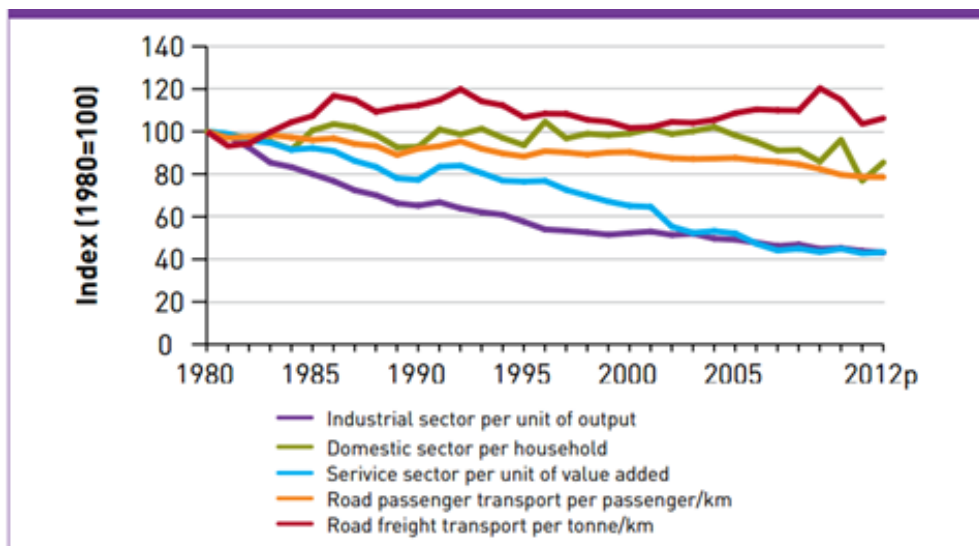

Figure 9 : UK Energy Intensity (DECC 2013a)

Figure 10 though shows one of the main areas of concern, that is, the reliance on imported energy to power the UK homes and Industry. As shown, between 1980 and 2003 the country was in effect exporting energy. Now reliant on imports the UK is now prone to political and commercial activities outside of its control.

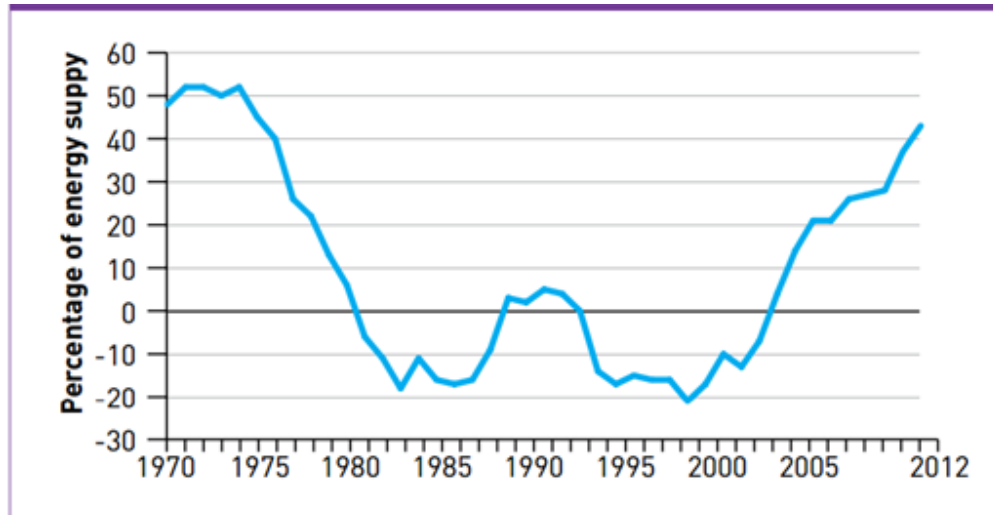

Figure 10: UK Energy Import Dependency (DECC 2013a)

Figure 11 then goes onto show the knock on cost effect to UK Industry. With increased Green taxes, as part of the drive to reduce GHG emissions, and increased reliance on imports are costing UK industry heavily. What stands out is the long term declining electricity prices between 1980 and 2003 which correlates with the UK's ability to export energy as shown in figure10. As the UK started to rely on imported energy, around 2003, figure11 clearly demonstrates the cost effect to UK industry. This will have discouraged investment in energy efficient technologies. With energy getting cheaper industry would have struggled to build a business case and invest. Then the sudden price hike has completely transformed industry's attitude to energy efficiency.

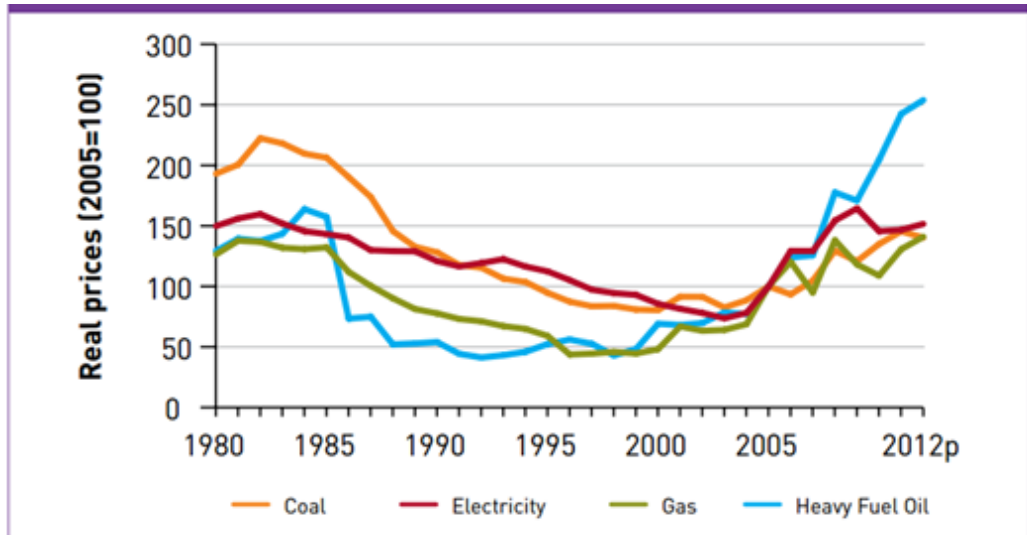

Figure 11 : UK Industrial Fuel Prices (DECC 2013a)

With projected shortages of supply and increasing energy prices the UK's energy position might be defined as 'less than supportive' to heavy industry. However, the sudden price rises have forced consumers to be more efficient. The American Council for an Energy Efficient Economy [ACEEE] has calculated that the UK is in fact the most energy efficient country in the world (ACEEE 2012). The ACEEE used several measures to determine Energy Use per Capita calculating total efficiency of generation and consumption. As previously shown in Figure 9, it can be seen that UK Industry has responded to the price rises and uncertainty of supply by reducing its energy intensity. High energy prices have forced UK industry to become more energy efficient even through the recent economic downturn. With energy prices so high, the payback on capital investments has reduced thus making investment in energy efficiency more viable.

Figure 12 compares the price of electricity paid by UK industry to the rest of Europe. By offering incentives and methods of tax relieve local government can vary this amount accordingly. In the UK , with the government committed to reducing carbon emissions below 80% of the 1990 level by 2050 and the proposed new Green Tax laws,

on top of the EUETS and the other taxes, in 2011 the UK government planned to impose an additional £28.30 per MWh for the UK Steel Industry (ICF 2012). This would significantly have increased electricity prices in the UK and would have taken them above that of Japan.

*EU industrial electricity prices for extra large users July 2008 - Dec 2013**

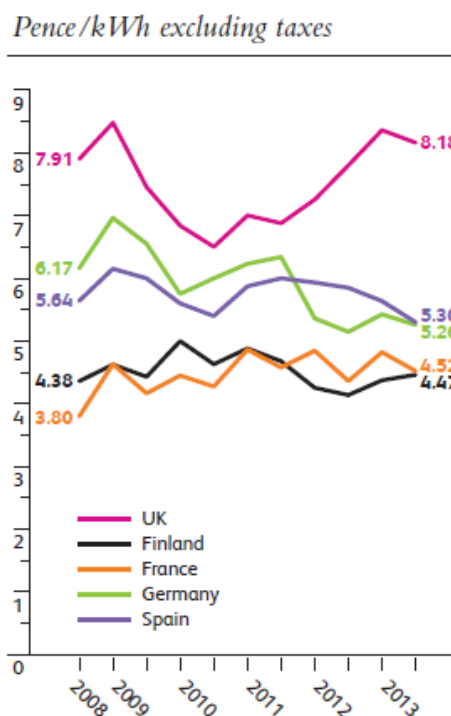

UK, EU and US forward wholesale gas prices 2008 - 2013 by quarter

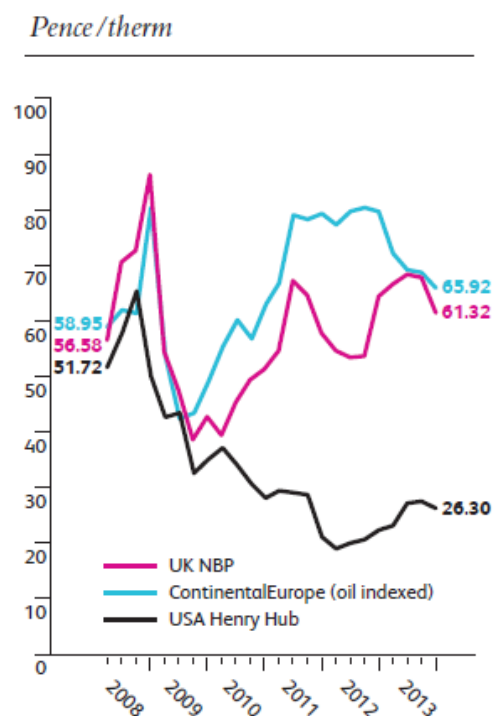

Figure 12 : Electricity and Gas Price Trends (EEF 2014)

After much lobbying, in 2013, the UK Government introduced a “250m compensation package for ‘energy intensive industries’”(GOV, 2014). As of August 2014, the detail for this compensation is not yet understood.

Within Europe itself the Centre for European Policy Studies [CEPS] publication ‘The Steel Industry in the European Union: Composition and drivers of energy prices and costs’ discusses the various costs paid and drivers behind the energy prices and the effect on the competitiveness of the EU steel industry. (Studies, 2013)

1.5. Energy Flows in the Steel Industry

The European Communities [EC] BREF document(EC 2013b) ,as shown in Figure 13,defines and describes the main energy flows in an integrated steelworks. The energy demand is high with an integrated steelworks consuming as much electricity and gas as a medium sized city. The flows are complex and interlink the various process operations around the site. This results in difficulty of measurement and exacerbated inefficiencies. The waste gases from the Coke Ovens, Blast Furnace and Basic Oxygen Steelworks are all captured and reused, either as a Natural Gas replacement for heating purposes, or combusted in a boiler to generate steam for electrical generation. In fact it's not unusual for a modern steelworks to be self sufficient for electricity and natural gas and even be in the position to occasionally export electricity.

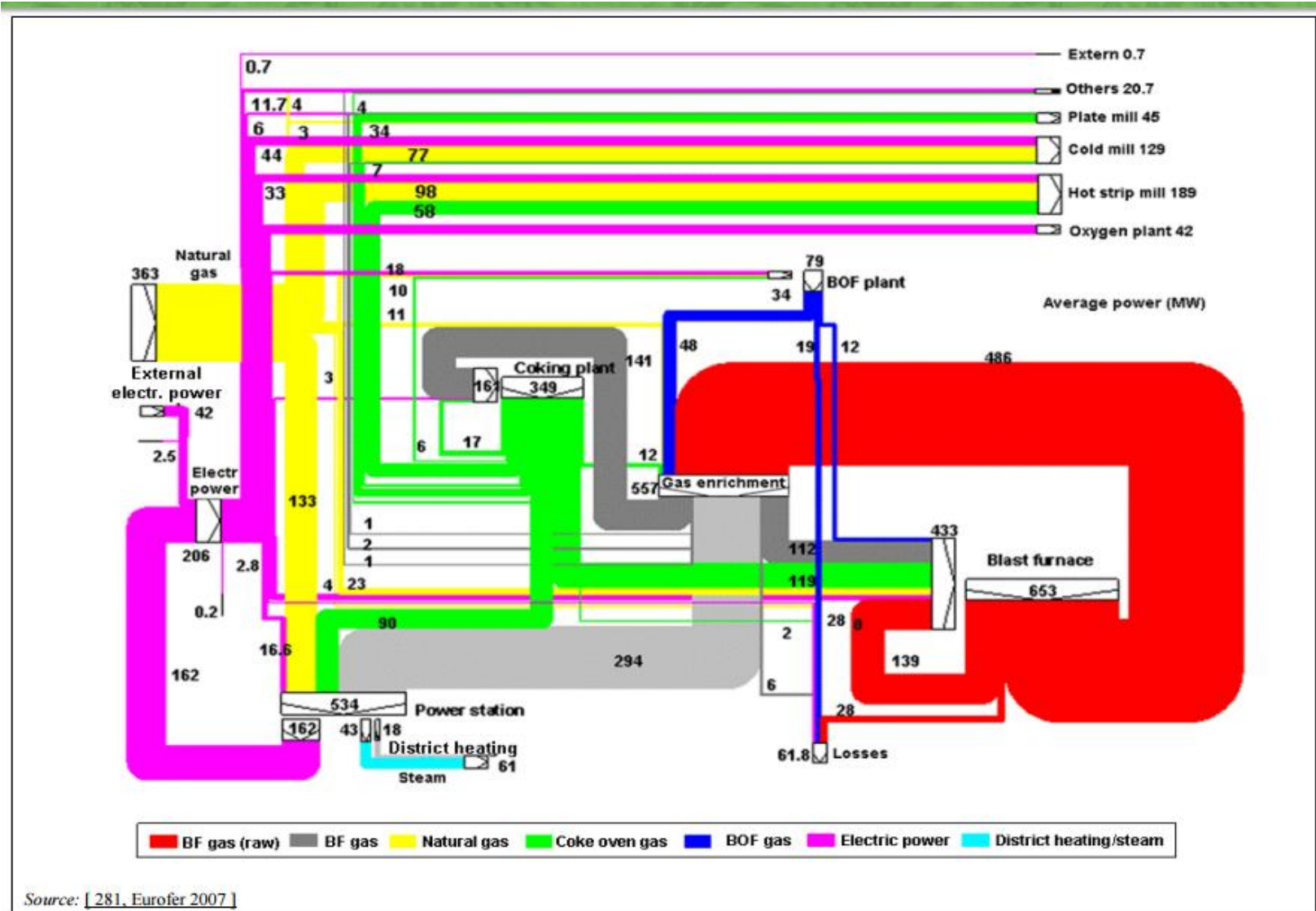

Figure 13 Typical Energy Flows in an Integrated Steel Works (EC, 2013b)

1.6. Energy Efficiency in the Steel Industry

As stated by the World Steel Association (WSA), the world's steel industry is now 50% more efficient than back in 1975(WSA 2013a). The WSA is one of the largest and most dynamic industry associations in the world. It represents around 85% of world steel production and acts as a focal point for the steel industry, providing global leadership on all major strategic issues affecting the industry.

In the EU there is Eurofer and the EC published BREF (EC 2013b), in the USA there is the American Iron and Steel Institute and then there is Asia Pacific Partnership. There are also other bodies such as the 'International Steel Statistics Bureau' [ISSB] and in the UK the 'UK steel', The Carbon Trust, Engineers' Employers Federation [EEF] and of course DECC. All of which are either groups of companies, Government agencies or organisations that compile and produce statistics for the steel industry.

When researching the subject, references go back as far as 1882 when Jeans, JS. (J.S.Jeans 1881)published the paper "On the consumption and economy of fuel in the iron and steel manufacture" in the Iron and Steel Institutes Journal. Then in 1961, "The effect of the various steelmaking processes on the energy balances of integrated iron- and steelworks" published by the Iron and Steel Institute(Group 1961) which shows Sankey diagrams for the steel making processes used at the time highlighting energy losses such as waste heat.

Through literature survey the technologies shown in Figure 14 are some of the available technologies that could possibly be employed.

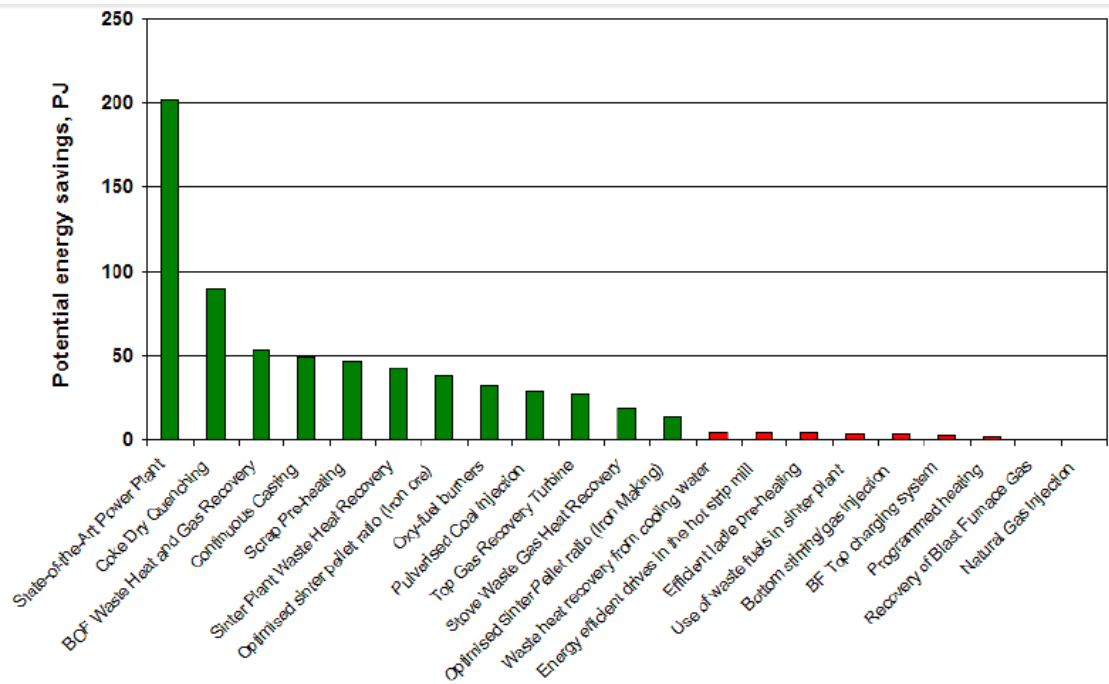

Figure 14: Energy Reduction Technologies (EC 2012)

The technologies listed are a summary of recommendations from the following publications. The two most important, all-encompassing publications are regarded as being:-

- “Energy Use in the Steel Industry” (IISI 1998)
- “Future Technologies for energy-efficient iron and steel making” (*de et al.* 1998)

Both these documents are very comprehensive and are referenced many times by more recent publications. The 1998 IISI paper is in fact an update from an earlier IISI publication ‘Energy in the Steel Industry’ 1982, and a published update in 1992 and 1996. It goes into real detail defining typical energy consumptions by the various parts of the process. It also details ‘case study’ examples and compares energy efficiencies of the differing technologies available at that time. The 1998 paper culminates the available technologies into two groups ‘Ecotech’ and ‘AllTech’. ‘Ecotech’ are technologies which were

financially viable and there likely to be adopted, and then 'Alltech' are all technologies that could be employed regardless of financial payback. The IISI paper (IISI 1998) shows the GJ/T of current technologies as being 17GJ/tls or greater and the effect of employing 'Ecotech' drops it down to 15GJ/TLS and then 'Alltech' would see a potential further reduction to 13GJ/TLS. Each process [ie Coke Making, Iron making etc] is Sankey diagrammed and available technologies explored. The publication also discusses R&D type technologies and projects their energy efficiency potential. The IISA became the WSA in 1998 and its 2008 publication 'Steel and Energy' fact sheet. (WSA 2008)

The US Environmental Protection Authority [EPA] publication, 'Available and emerging technologies for reducing Greenhouse Gas emissions from the Iron and Steel Industry'(EPA 2012) gives a good over view of GHG and energy reduction technologies. Then the EPA's other publication 'An Energy Star Guide for Energy and Plant Managers' (EPA 2010) is written as a guide for plant managers and people managing energy plans for the steel industry. Then the 'Asia Pacific Partnership for Clean Development and Climate' publication 'The State-of-the-Art Clean Technologies [SOACT] for Steelmaking Handbook'(Climate 2010) is written by the American Iron and Steel Institute and describes each process and the energy efficient opportunities and technologies that exist. 'Energy Consumption and CO₂ Emissions Benchmarking and Modelling in Port Kembla Steelworks' (Paul 2011) is an example of where a model has been developed of a steelworks. Energy efficient technologies are then applied to the model and improvement projections are made. For a European perspective the EC publication 'Best Available Techniques [BAT] Reference Document for Iron and Steel Production' (EC 2013b) is written almost for a layperson and each process is defined in great detail. Examples are given of typical installations and BAT.

The ‘Prospective Scenarios on Energy Efficiency and CO₂ Emissions in the EU Iron & Steel Industry’ (EC 2012)

Looking more locally, the Centre for Low Carbon Futures publication “Technology Innovation for Energy Intensive Industry in the United Kingdom” (Futures 2011)

The above documents provide up-to-date information with the basics of steelmaking, where energy is used, available technologies and their likely impact on energy efficiency.

Although every steel works is very different and so not one rule will fit all. The papers do define a theoretical best practice and discuss technologies that may be employed to reduce energy consumption. From these publications it is possible to conclude that for an Integrated Steelworks the BAT would be somewhere around the 19 GJ/Tonne and the technologies listed in Figure 14 could be utilised in order to achieve such a Specific Energy Consumption [SEC].

In summary, there are many publications discussing energy efficiency in the steel industry. Due to differing development and political histories, the fact is that not all steelworks are the same. With countries around the world having contrasting energy costs and policies each country will have a distinct attitude towards heavy Industry. It is therefore not possible to have one energy efficiency plan that would fit all steelworks. Each individual steelworks requires its own energy efficiency strategy and roadmap to fit its particular needs and drivers.

1.7. Energy use in the UK steel Industry

According to DECC (DECC 2012a) the Steel Industry Uses around 1.2% of UK energy and is 13% more efficient since 1990. However, as discussed earlier, with the UK now importing around 36% of its energy, industry is facing a period of uncertainty with energy

prices increasing and hence the associated manufacturing costs are difficult to control. Also with around 25% of the UK's power generating capacity projected to close within the next 10 years (DECC 2011), this obviously raises real concerns and uncertainties. The possibility of 'industrial blackouts' and ever increase energy prices are a significant threat to future industrial stability and growth.

The UK Iron and Steel Industry accounts for about 16% of the UKs industrial GHG emissions (Futures 2011). Technologies for GHG reductions are being developed (Futures 2011) but these developments are experimentally based and will require large capital investment programs. It has been estimated that for the steel industry alone about £1.5billion of investment is needed (Futures 2011). In the current financial climate of low demand and poor prices for its products, this level of investment is not sustainable. The likely scenario is to close plants rather than invest. Hence more practical ways of tackling these discharges need to be considered.

Only a proportion of the industry's GHG emissions are due to electricity and gas consumption (Allwood and Cullen 2012). Process operations such the recycling of scrap percentage in steelmaking and the levels of coal injection in Blast Furnaces for example are some of the main contributors to large discharges of CO₂ per tonne per unit product. Hence energy and process efficiency still have a vital role to play in any plans for sustainable GHG emission reduction target(Allwood and Cullen 2012).

With increasing energy costs followed by real concerns about security of electricity supply and the possibility of massive tax bills the Steel Industry in the UK has been forced to invest considerable resources into exploring the optimum road map for increased energy

efficiency and driving the self-sufficiency agenda in the context of poor demand for its products.

Figure 15 shows the trend for the Specific Energy Consumption [SEC] for the UK steel Industry. So between 1973 and 2012 the Industry become more efficient per Tonne. In 1973 the SEC was 31.7 GJ/Tonne of product then by 2012 the SEC had reduced to 18.8 GJ/Tonne. This represents an improvement of just under 60%.

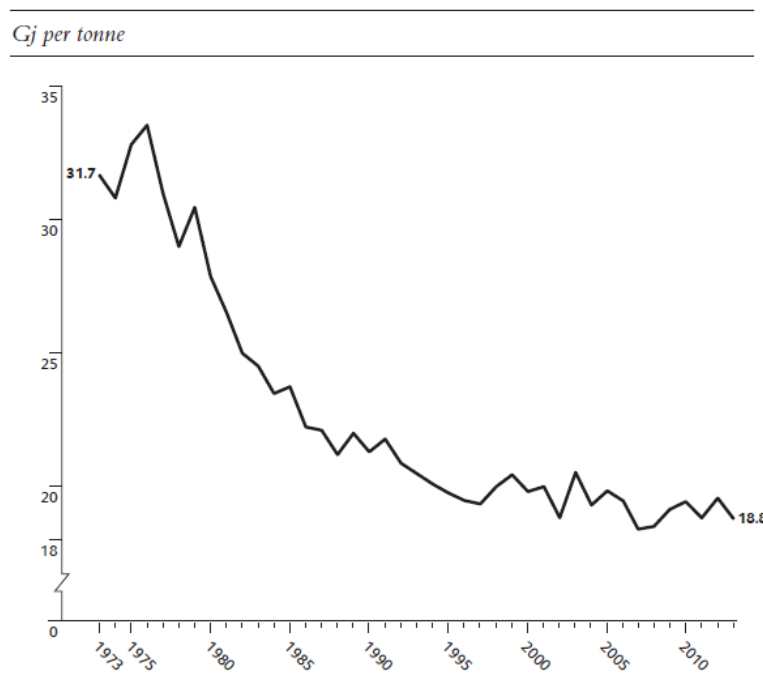

Figure 15 : UK steel Industry Energy Intensity (EEF 2014)

In relation to the rest of the world WSA published data indicates a worldwide typical reduction of 50% in energy consumption since the early 1975 for the top steel making countries (WSA 2008). So with the UK having a 60% reduction, although this is only a relative comparison, with an undefined base line, it does indicate that the UK Steel Industry has in general kept up-to-date.

However if digging into the detail and examining the Best Available Technique [BAT] it soon becomes clear that the UK has some catching up to do for its primary steel production route in the Integrated Steelworks [ie Blast Furnace & Basic Oxygen Steel making].

The 18.8GJ/Tonne for 2013, shown in Figure 15, is of course an average of steel making via the BF and the EA manufacturing route. The EEF 'key facts' (eef 2014) shows that for 2013 16% was made via the EA route which, according to the EC paper (EC 2012), has a typical SEC of 11 GJ/Tonne where as the BF route has a typical SEC of 21 GJ/Tonne.

So if 16% of the steel is made with a SEC of 11 GJ/Tonne then the 84% must have been made via the BF route with a SEC of at least 20 GJ/Tonne.

If fact communications from an example UK steel works states a SEC of 24GJ/Tonne (Steel 2014) and then compare that to a BAT of maybe 15GJ/Tonne as quoted previously in the 'Energy in the Steel Industry' IISI paper (IISI 1998) it is clear to see that the UK has therefore probably has technologies that it has not employed.

1.8. Summary and Aim of this work

This chapter explains that Global, and local, Climate change and Energy Policies have put pressures on the steel Industry. Energy efficiency is defined as key to reducing GHG emissions and technologies to improve energy efficiency are explored. In the UK the lack of clear long term Energy Strategy has resulted in high energy prices and risks to security of supply of energy to Industry. This though, in itself, has driven Industry to be more efficient. Even so, a simple examination of a UK Case Study Steel Works [CSSW]

highlights that its SEC is poor compared to BAT and therefore asks the question ‘is there an area of technology not yet employed by the UK integrated steel works?’.

The aim of this project is to study a UK based ‘case study’ steelworks. Its energy systems and performance are to be analysed and compared against Best Practice. The case study works is therefore to be benchmarked, in terms of energy efficiency, and a technological area of energy efficiency that has not yet been exploited is to be identified. This technology is to be investigated, researched and its implementation modelled.

The aims are thus:-

- 1} Study UK based CSSW, Study its energy flows, compare against BAT and identify a technology not yet employed to improve Energy Efficiency.
- 2} Research the technology identified in Aim 1.
- 3} Investigate the potential impact on the CSSW.
- 4} Model the technologies implementation.
- 5} Scope a strategic outlook for the CSSW.

1.9. Structure of the Thesis

This Chapter has defined the context of the thesis, described the issues facing the UK steel industry and the potential technologies that could be employed to improve energy efficiency. The chapter finishes with a simple comparison of a UK case study SEC and compares it to BAT. Thus the chapter concludes that there is further potential for the CSSW to save energy and defines the aims of this project.

Chapter 2 is then an overview of the steel industry and an introduction to the CSSW finalising in the statement of the technology that's implementation is to be modelled.

Chapter 3 is an overview of Waste Heat recovery and Chapter 4 describes steam distribution and the possibility of its use when considering WHR at the CSSW. Chapter 5 is a critical assessment of the modelling software used to model the steam system at the CSSW. Chapter 5 also overviews the Model itself and thus defines the methodology and all assumptions made. Chapter 6 is a discussion about the results of the modelling and Chapter 7 discusses the development of a WHR strategy for the CSSW.

Chapter 8 covers the conclusions and Chapter 9 recommendations and details some further work proposals.

2. The Steel Industry

2.1. Introduction

This chapter provides an overview of the World, European Union [EU] and the UK steel industry. A UK based CSSW is described and its energy flows are examined and compared to best practice as defined in published literature. A technological area of energy savings that is not employed at the CSSW is defined and explored.

2.2. How to Make Steel

Steel has two main manufacturing routes, as shown in Figure 16, that is, the Blast Furnace or Electric Arc routes. The primary input for the Electric Arc is scrap steel, while the blast furnace relies on iron ore and coke as its main resources. The Blast Furnace [BF] combined with Basic Oxygen Steelmaking [BOS] as the predominant steel making process. In developing countries, where there tends to be a limited quantity of scrap, the Electric Arc furnace is not practicable. A ‘Secondary steelmaking’ process, for example Vacuum Degassing, is often employed to refine the steel to the required grade.

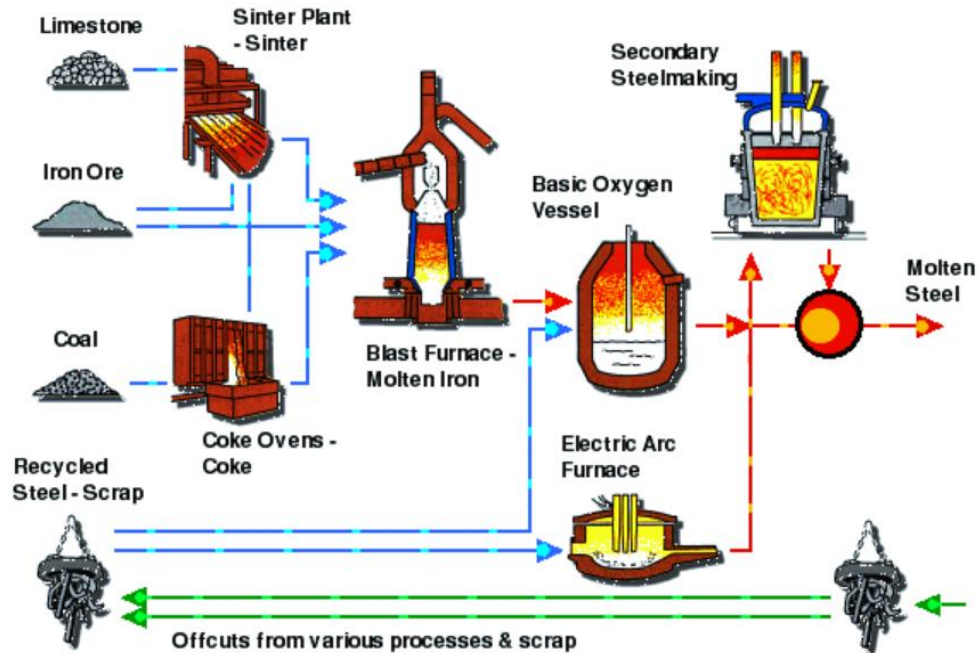

Figure 16 The Steelmaking Process (EEF 2014b)

The refined steel is then cast into slab, billet or bloom in a Continuous Caster known as ‘Concast’. The liquid Steel flows from a valve in the bottom of the ladle, into a holding tundish and then into the mould which has a water cooled outer body. The steel then starts to solidify as it drops out of the mould and into the ‘strand’ of supporting rollers where it is further cooled with sprayed water and is guided by water cooled rollers. As the steel solidifies throughout the strand it is guided and cooled further until it reaches the cutting machine, by which time it has fully solidified. The steel is then cut to the required length and sent for further processing as Slab, Billet or Bloom depending on the final product specification. As shown in Figure 17, most Slab, Billet or Bloom will then be processed through Hot Rolling. Some products will go on to be pickled, to remove the scaled layer on the surface of the steel, then cold rolled, annealed and possibly coated. Steelworks that contain BF, BOS, Concast and mills are known as ‘Integrated Steelworks’.

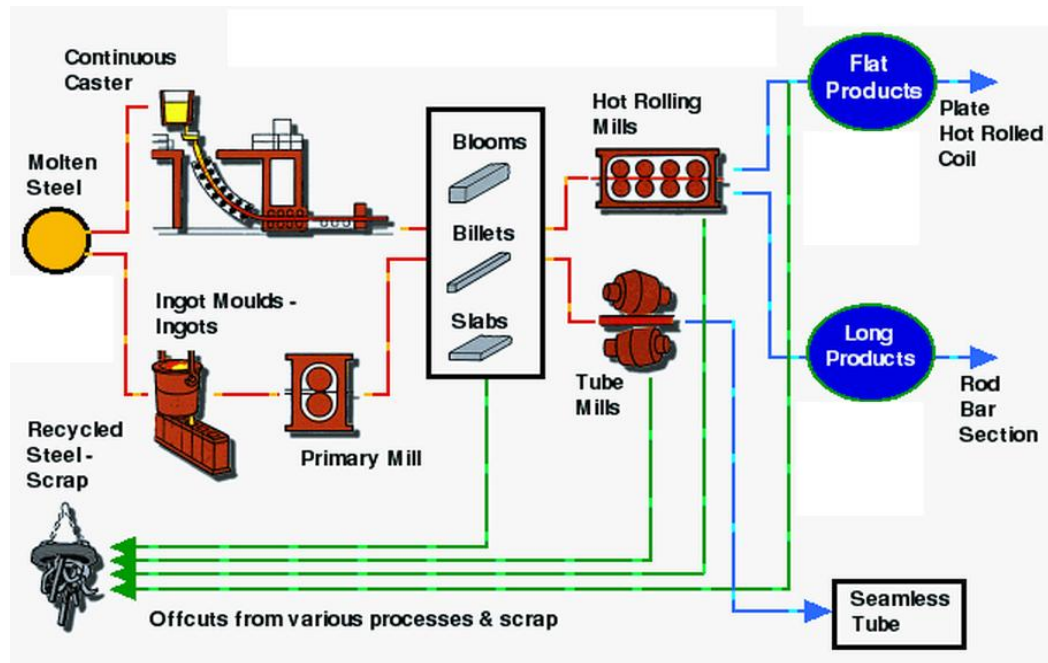

Figure 17 The Steel Manufacturing Process (EEF 2014c)

2.3. Consumption of Steel

The Engineering Employers Federation [EEF] website states ‘*Steel is vital to our everyday life. We depend on steel for housing and health. Without it there would be no offices or retail parks. It is at the root of the quality of life that each of us enjoys today, helping to shelter us, to feed us and to facilitate both our working and our leisure day*’ (EEF 2014a)

Figure 18 shows 2011 data for the worldwide consumption of steel. It is clear that 51% of all steel made is used in construction highlighting how susceptible the steel industry is to the effects of economic volatility and has been more pronounced since 2008 when the current recession has started. The recent economic downturn and the slump in the construction sector has therefore had a major impact on the steel industry.

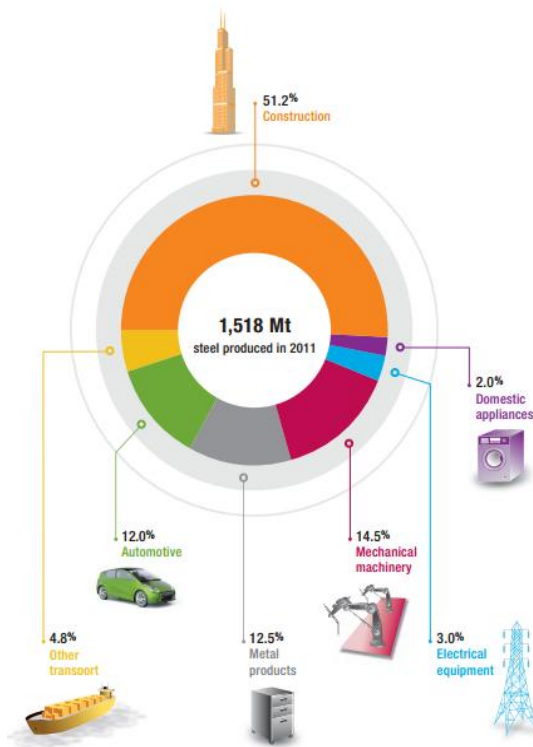

Figure 18 : Worldwide Consumption of steel (WSA 2012)

2.4. The Worldwide Steel Industry

The WSA website states (WSA 2014) *‘The industry directly employs more than two million people worldwide, with a further two million contractors and four million people in supporting industries. Considering steel’s position as the key product supplier to industries such as automotive, construction, transport, power and machine goods, and using a multiplier of 25:1, the steel industry is at the source of employment for more than 50 million people. World crude steel production has increased from 851 megatonnes in 2001 to 1,548 Mt for the year 2012. [It was 28.3 Mt in 1900]. World average steel use per capita has steadily increased from 150 kg in 2001 to 215 kg in 2011. India, Brazil, South Korea and Turkey have all entered the top ten steel producers list in the past 40 years.’*

The steel industry in differing countries around the world has historically been seen as a strategic core element to any successful country (Fairbrother et al 2004). The industry was historically nationalised and then in attempts to improve productivity has been globally privatised. The industry has also undergone several rationalisations and mergers to make itself more sustainable. Even so it has still been necessary for governments to step in and protect their steel industry from time to time [for example the US tariffs on imports 2002] (Fairbrother et al 2004). The publication by the EC (EC 2013c) explains the fact that the EU steel industry is at a big disadvantage at the moment due to worldwide governmental protection of the each countries steel industry. It explains that countries are placing import tariffs or export tariffs on raw materials as ways of protection. It presents a plan to try to help the EU steel industry in terms of training, access to foreign markets and increasing local EU demand.

The EEF diagram shown in **Figure 19** shows the ever increasing production of steel by year. As can be seen the amount made through the BF route is over 400% of that made by EA. The diagram also shows a small and decreasing amount of steel made from other routes. This would have been older technologies [ie Open Hearth] but also some from DRI [Direct Reduced Iron].

Output - EU/world

World crude steel production 1995 - 2011

Million tonnes

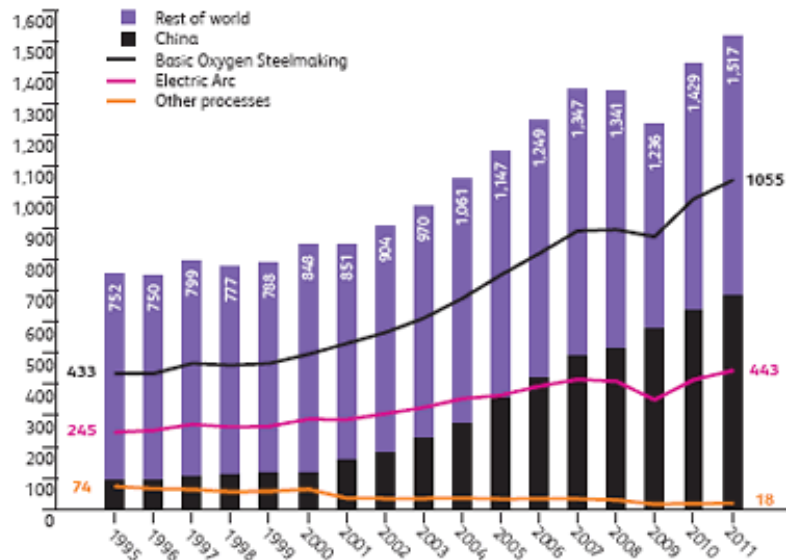

Source: World Steel Association

Figure 19 : World Steel Production (EEF 2014d)

2.5. The European Steel Industry

The European steel industry sees itself as a technological and environmental leader. In its review of the European Steel Industry, February 2013, the European Commission states *'The European Steel industry is a world leader in its sector with a turnover of about EUR 190 billion and direct employment of about 360 000 highly skilled people, producing 178 million tonnes of steel per year in more than 500 steel production sites in 23 EU Member States. The European steel industry is among the world leaders in its environmental performance and resource efficiency.'* (EC 2013).

As shown in **Figure 20** the main European steel makers produced about 11.7% of the world's steel in 2012. It can also be seen that the EU consumes around 11.1% of world steel. This implies almost self-sufficiency but this is of course not the case as shown by Eurofer with the EU importing around a 10% of its steel consumption 2012 (Eurofer 2012). With free trade around the world the EU imports and exports differing grades and sections of steel for differing applications. **Figure 20** again demonstrates the huge impact of a developing China.

2011

Production:

World total: 1,518 million tonnes crude steel

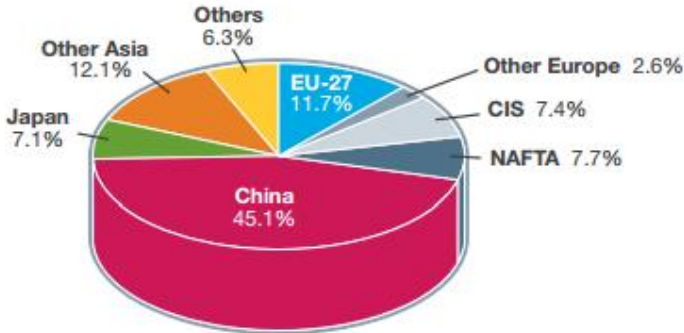

Use (finished steel products):

World total: 1,371 million tonnes crude steel

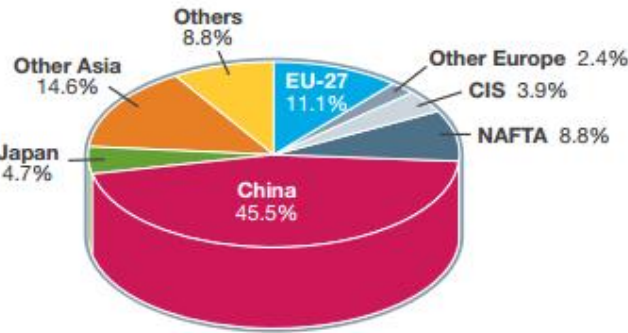

Figure 20 World Steel Production by Country (WSA 2012)

The steel industry in the EU is geographical spread around its member state countries (EC 2013b). Figure 21 shows steel production by country in 2008. Germany is the main producer, followed by Italy, Spain, France then the UK with 7%.

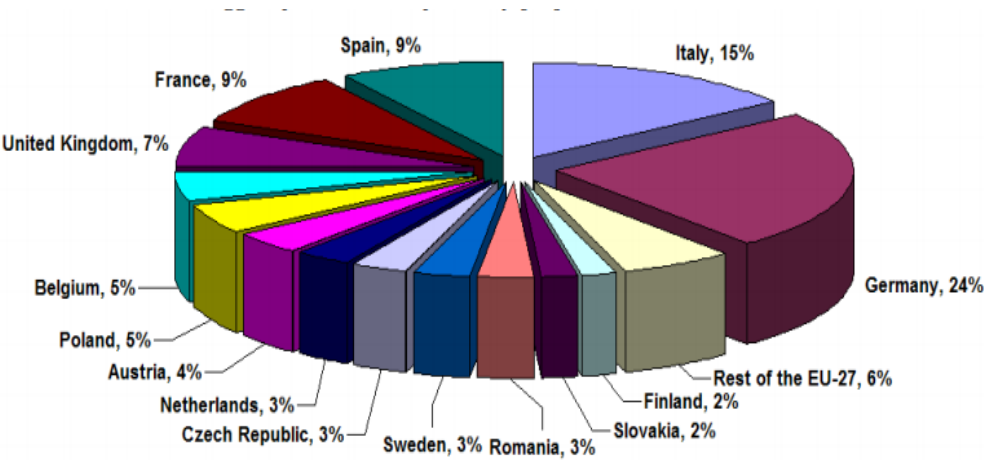

Figure 4: Crude steel production in the EU-27, in 2008

Figure 21 European Steel Production per Country (EC 2012)

Figure 22 shows the historic production of steel in the EU between 2003 and 2012. The step change following the global downturn of 2008 is evident. The UKs steel production is within the ‘Other EU15’ category on the figure. Throughout Europe many steelworks were mothballed or suffered a reduction in volumes as producers tried to financially survive.

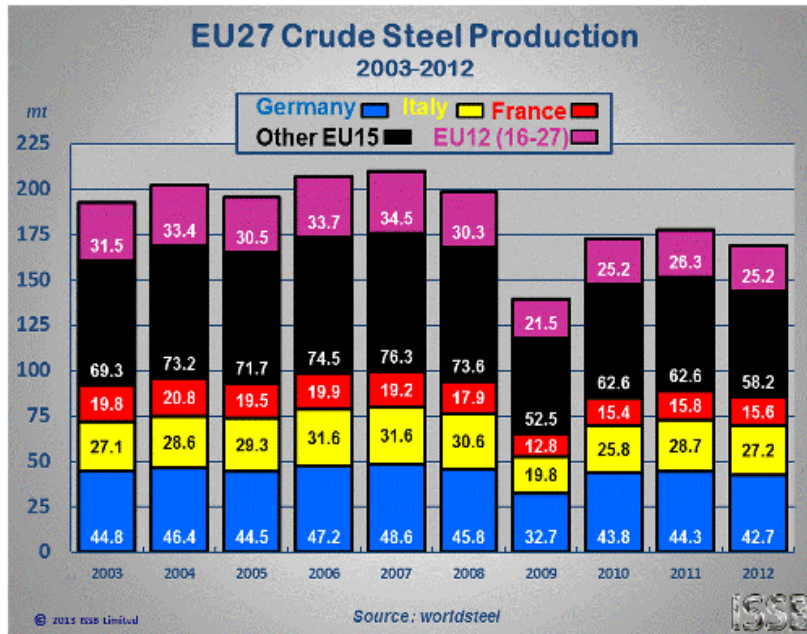

Figure 22 European Steel production per Country (ISSB 2014)

2.6. UK Steel Industry

Since the 1970's the Steel Industry in the UK has been decimated. In 1967 when the steel industry was nationalised it had over 250,000 employees. It then suffered successive restructuring and was again privatised in 1988. Figure 23 (EEF 2014d) shows the declining production volumes and employees since 1991 as Blair described in his publication "The British iron and steel industry since 1945".

Annual crude steel production and numbers employed 1993 - 2013

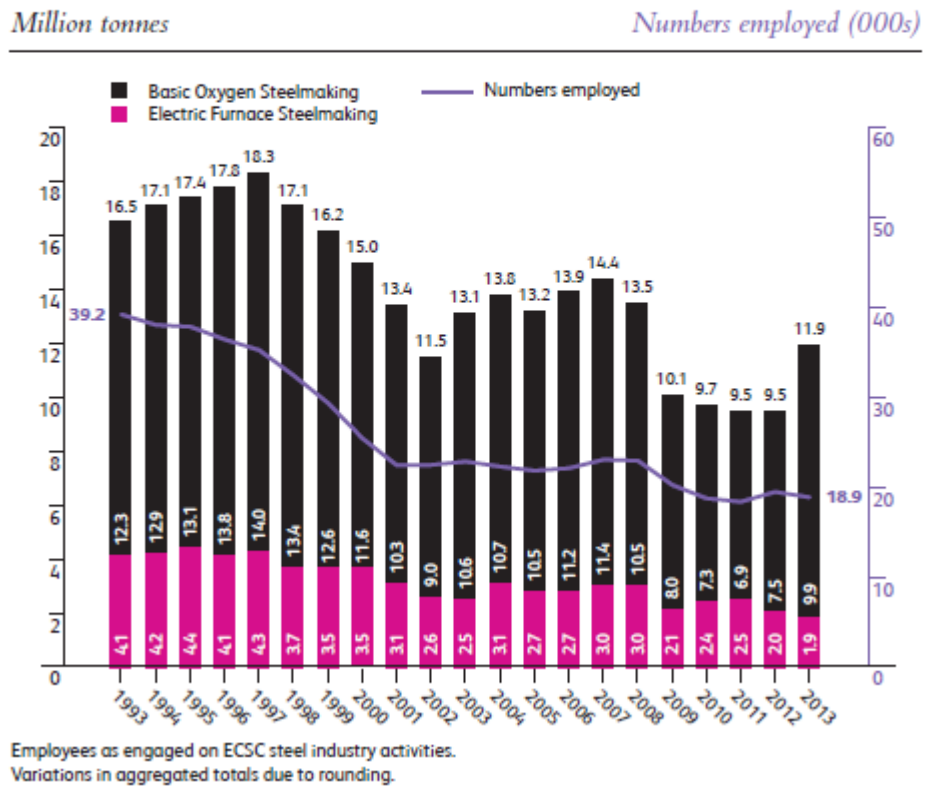

Figure 23 UK Steel Production History (EEF 2014)

Today the country only has three Integrated Steelworks

- Port Talbot Steelworks [Owned by Tata Steel]
- Scunthorpe Steelworks [Owned by Tata Steel]
- Teesside Steelworks [Owned by SSI and restarted production in April 2012]

There are EA and steel processing plants located in different parts of the country for example Celsa Steel in Cardiff.

The UK faces many challenges in today's business world as discussed by the Financial Times in its video 'Is there a future in UK steel?' (FT 2014). The video expands on

concerns about the fact that the UK industry is investing but with tough challenges from Green Taxes and higher costs. To show this graphically Figure 24 shows the increase in iron ore prices and the volatility of the Coal price. It can be seen that Iron Ore price has doubled since 2008. Coal Prices also doubled between 2008 and 2010 but then mainly due to the shale gas developments in the USA the coal price has now dropped back to about half the price it was in 2008.

*Raw material costs - iron ore & hard coking coal
Jan 2008 - Mar 2014*

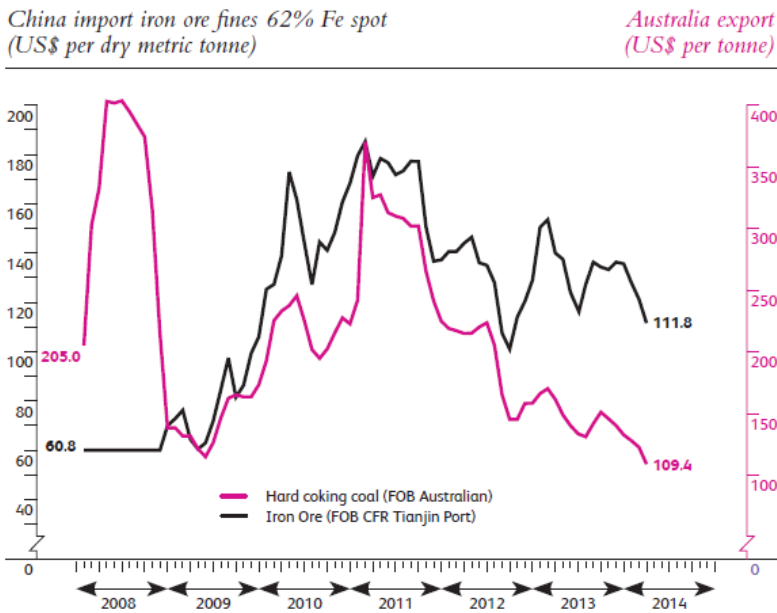
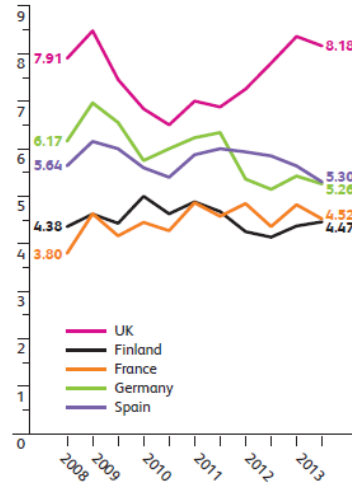

Figure 24 Steel Industry Raw Material Prices (EEF 2014)

Figure 25 then shows the relatively high prices of energy in the UK and compares it to other EU countries. As can be seen the electricity price is about 50% higher than other EU countries. The gas price is approximately 10% cheaper than the rest of Europe.

*EU industrial electricity prices for extra large users July 2008 - Dec 2013**

Pence/kWh excluding taxes



UK, EU and US forward wholesale gas prices 2008 - 2013 by quarter

Pence/therm

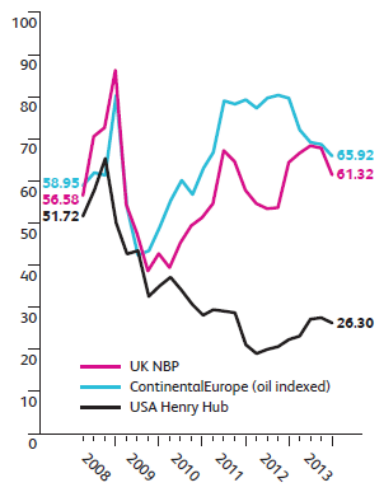

Figure 25 European Energy Prices (EEF 2014)

Figure 26 then shows the relative price of steel in the UK market when compared to the Retail Price Index [RPI]. As can be seen the relative market price of steel has dropped when compared to the RPI. Steel is in effect therefore cheaper now than ever before but its manufacturing costs are higher than ever before.

Index of UK steel & aluminium price compared to RPI 1987 - 2013

Index (1987 = 100)

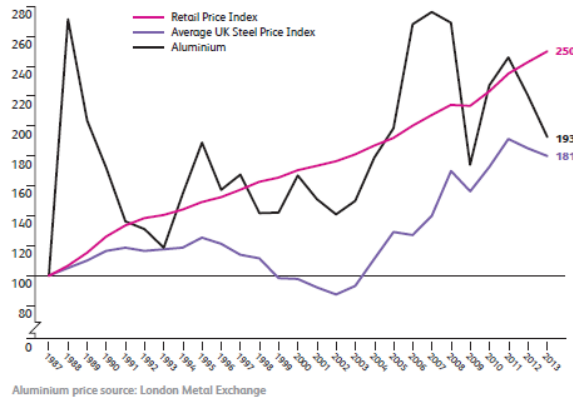

Figure 26 UK Steel and Aluminium Retail Price (EEF 2014)

This then partly leads onto the picture presented in Figure 27. It shows an effect of this relatively high production cost and low market value, that is of course higher imports. Customers are able to buy in and import steel at a cheaper price. As shown in the Figure 27 there is a long term decline in the amount of steel make in the UK that is used in the UK. Inversely the long term trend for increased imports is evident. It is clear to see that there is now more imported steel used in the UK than made in the UK. If you refer back though to Figure 23 it states that the UK produced 11.9MTPA in 2013. If only 4.2MTPA was used in the UK then the remaining 7.7MTPA must have been exported. Thus the UK must be a net exporter of steel and partly demonstrates how complex the world steel market is.

UK demand for steel mill products 1972 - 2013

Million tonnes per year

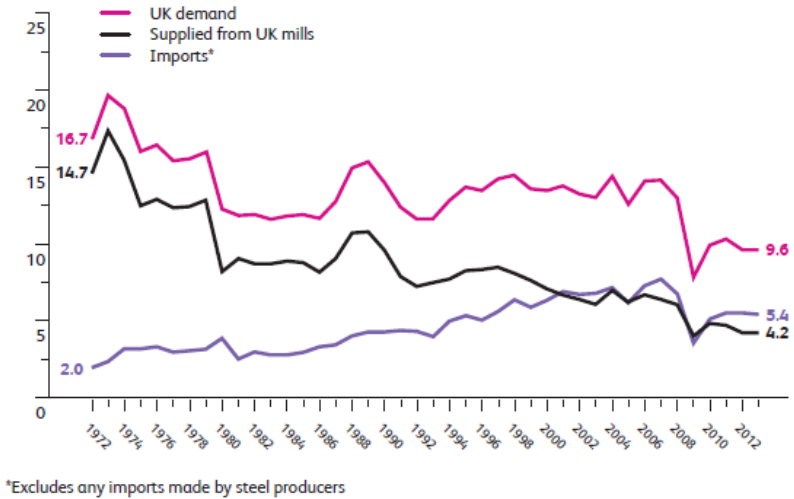

Figure 27 Historical UK Steel Demand (EEF 2014)

In a recent publication by Price Waterhouse Coopers, commissioned by Tata Steel, in 2014 (Coopers 2014) the demands on the UKs foundation Industries are discussed. The publication titled ‘Understanding the economic contribution of the foundation industries’

lays out the benefits and concerns of the foundation industries in the UK and then attempts to define the contribution and importance of such industries to various countries around the world. This is obviously an example of the UK steel industry reminding the UK government of the importance of the foundation industries to the UK economy as a whole, particularly outside London and the South East. High energy prices are highlighted as a real concern to competitiveness.

2.7. The Case Study Steel works [CSSW]

The case study steel works [CSSW] is Tata Steels Port Talbot Integrated works in South Wales. Records show that as early as 1253 the monks of Margam Abbey were granted permission to extract iron and ore from land belonging to Walter Lovel, Lord of North Cornelly (Parry 2011)

Large scale Steelmaking started in Port Talbot in 1902 at the 'Port Talbot Steel Works'. 'Margam Steel Works' then developed alongside in 1918 and then was joined by the massive Abbey Steelworks in 1951. All three were rationalized when under the ownership of the 'Iron and Steel Corporation of Great Britain'. Then under the 'Steel Company of Wales' Port Talbot and Margam steel works closed in 1961 and 1963, respectively, leaving Blast furnaces of Margam site and steelmaking and rolling at the Abbey Steel Works. Under the British Steel Corporation and then following privatisation in 1988 and the formation of British Steel PLC the site became known as 'Port Talbot Steel Works'(Protheroe-Jones 1995). In 1999 British Steel merged with the Dutch Koninklijke Hoogovens to form the Corus Group. Then in 2007 the Corus Group was taken over by Tata Steel, an Indian based company established in 1907. The site now covers an area of over a thousand hectares with 100 km of roads and has a deep-sea harbour.

The works is what would be defined as a traditional Blast Furnace route Integrated Steelworks and its process route is as shown in Figure 28. It contains Blast Furnaces [BF], Basic Oxygen Steelmaking [BOS] converters, continuous slab casters, hot and cold rolling mills and a continuous annealing line. To provide the process with raw materials the site also has a Sinter Plant [SP] and two batteries of Coke Ovens [CO].

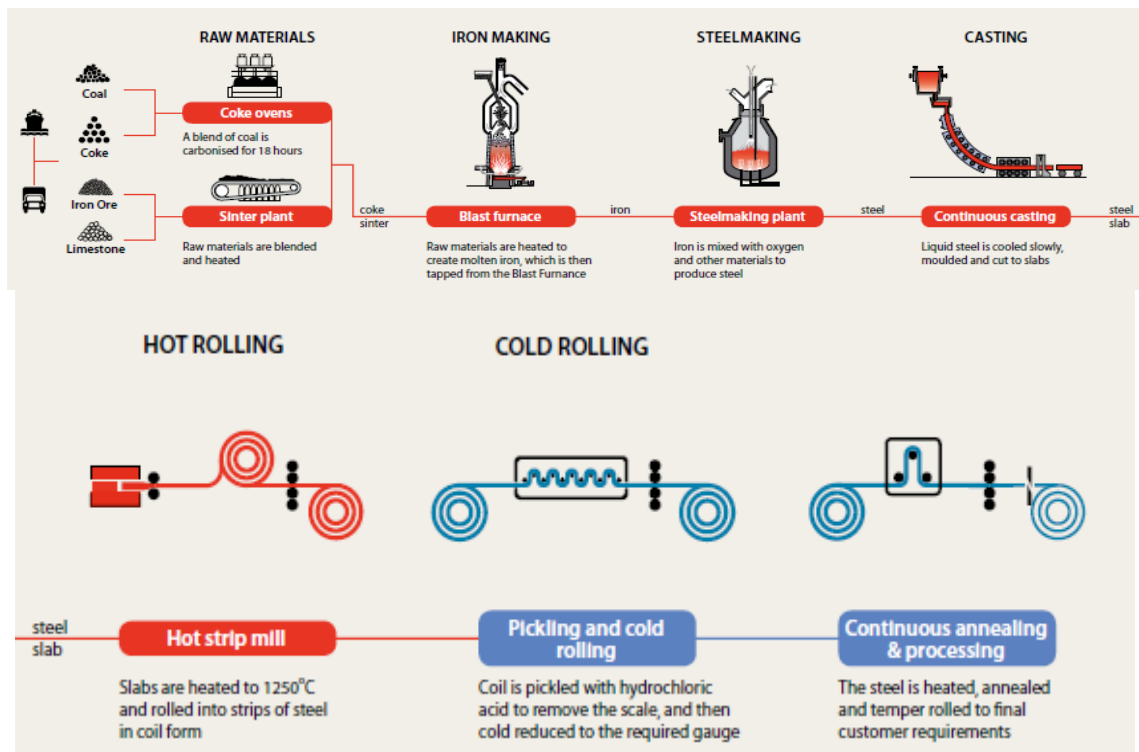

Figure 28: CSSW Process Flow (Steel 2011)

In 2005 the site embarked on an improvement drive, known as ‘The Journey’ to develop a ‘sustainable steelworks’. One important element of this drive was to analyse, investigate, benchmark and promote energy saving technologies and strategies. The key was to develop an independent function that was not constrained by both production and existing energy functions within the plant. Thus a separate structure was formed (Burggraaf 2011) titled the ‘Energy Optimisation Team’. Working with the other disciplines at the site, a future strategy for increased fuel and electrical efficiency gained momentum. This stimulated investment of over £100m worth of energy projects for example BOS Gas Recovery, efficient motors, pumps, lighting and variable speed drives. The main focus was on reducing the amount of flared indigenous gases, by improving their utilisation and thus reducing imported energy. To support this drive for energy efficiency the CSSW sought assistance from a local university who had expertise in this sector. The project had several

objectives including the study of waste heat recovery [WHR] and the improved utilisation of the site's steam system. This work presented in this thesis forms part of the output from the EPSRC project reference EP/G060053/1 (EPSRC 2009).

2.8. Energy flows in the CSSW

The CSSW is what is described as a traditional Integrated steel works. It recycles its indigenous gases for either steam generation in the power plant or to displace natural gas as a heating fuel. To understand the energy flows at the CSSW, a study was undertaken of energy data from the works. A spreadsheet was constructed and calculations used to derive the typical energy flows. Figure 29 shows the outcome of the study in the form of a Sankey diagram. What stands out of course is the large amount of energy provided by coal and coke. The Sankey shows the indigenous gases being used for BF stove heating, Hot Mill furnace heating and of course for steam generation in the Power Plant. The Sankey also helps define the total losses within the energy cycle. The total losses add up to a significant quantity for the year 2012/13. These losses are typically from furnaces stacks, cooling towers, radiant losses from hot products cooling down in between different processes.

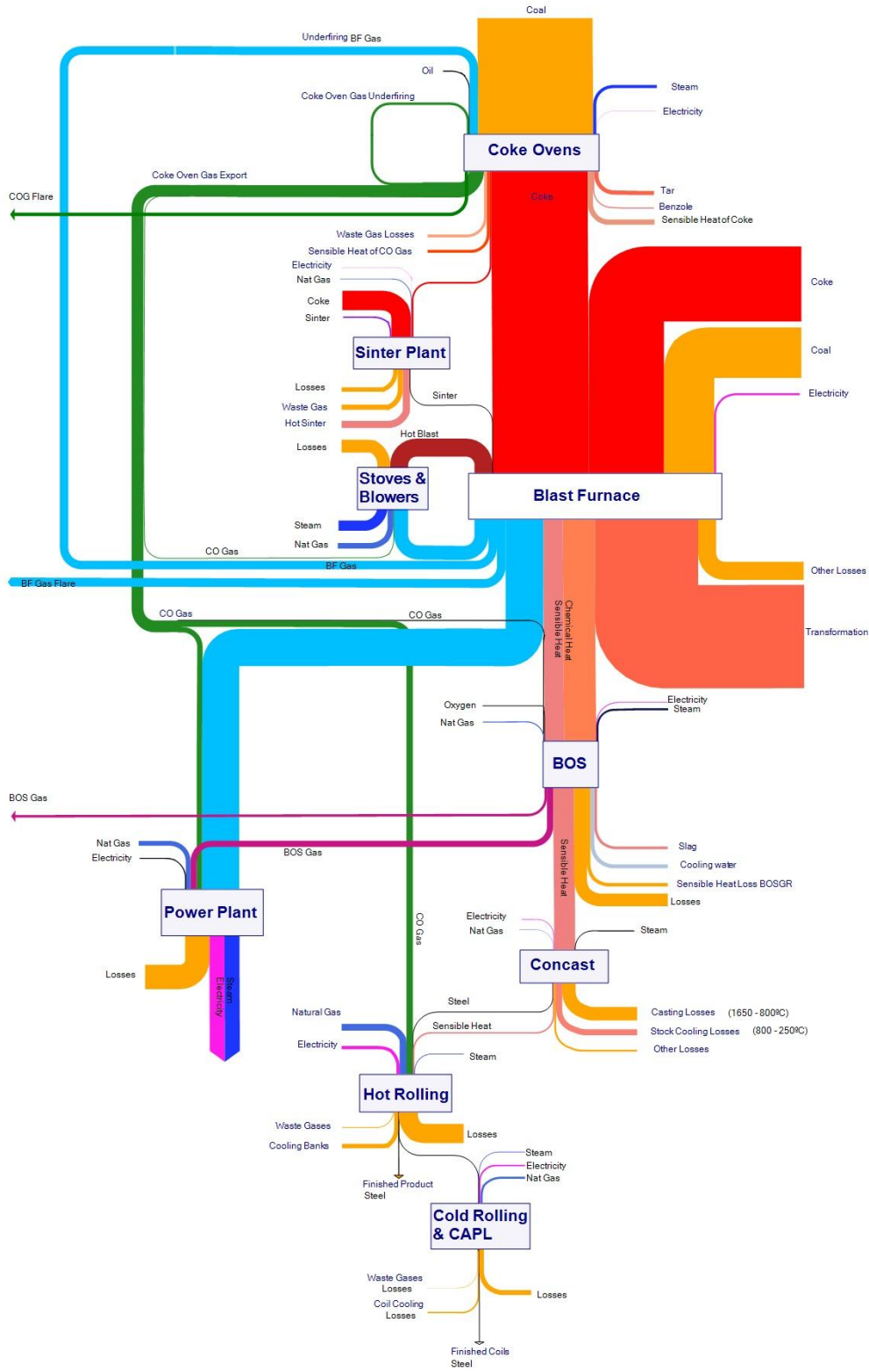

Figure 29 : Sankey Diagram for the CSSW

The study then focused on the gas flows as shown in Figure 30. The developed Sankey again shows up the recycling of the indigenous gases but also highlights the amount of gas flared. To utilise this flare the CSSW is exploring an extension to its existing power plant. This new power plant will utilise the flared gas to increase onsite power generation from an average of 75MWe to an average of 130MWe (Steel 2013).

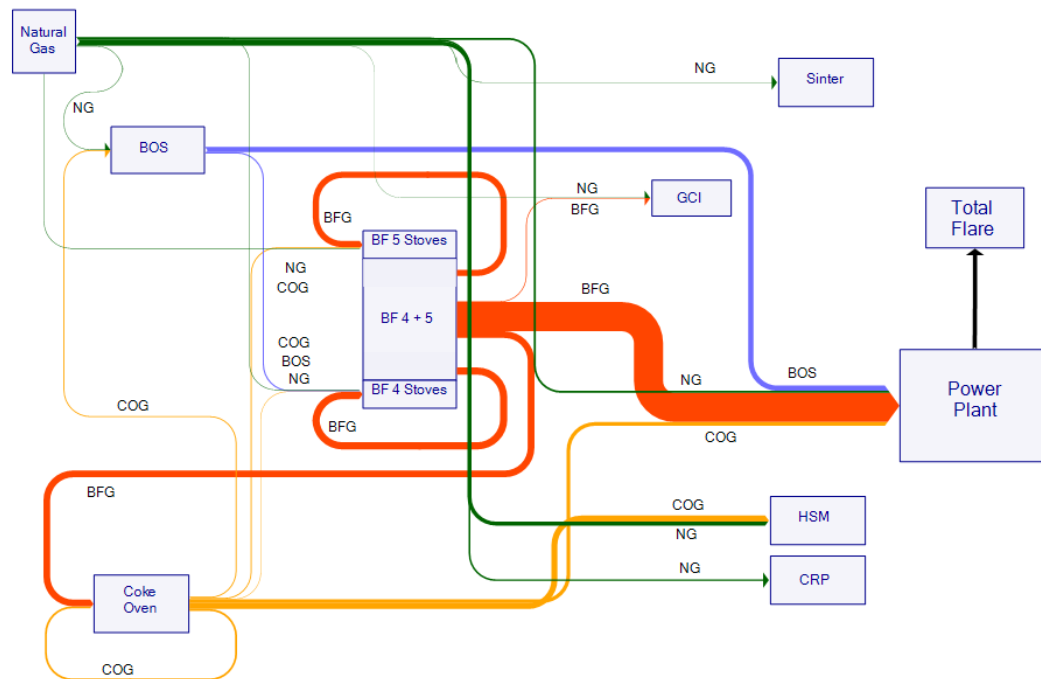

Figure 30: Case Study Sankey of Gas Flows

What's clear from the Sankey diagrams is the amount of flared indigenous gas and also the amount of losses. The CSSW are exploring a state of the art power plant to use up the indigenous gases, so referring back to list of technologies published by the EC in the document 'Prospective Scenarios on Energy Efficiency and CO₂ Emissions in the EU Iron & Steel Industry' (EC 2012) and shown in Figure 14, it's clear that Waste Heat Recovery features highly on the list of technologies that need to be explored for the CSSW.

During 2010 the plant started to further benchmark itself against its sister plants around the world as well as its competitors. The scale of the opportunity that WHR presented was soon made clear. Part of this assessment process the company's R&D facility undertook a plant wide exergy study (Patsos and Mullan 2011). This activity highlighted a number of high, medium and low grade waste heat sources that could be exploited. This study indicated that there was a potential of about 6GJ per tonne of crude steel available from WHR. If you put that in perspective with the works calculated stated of 24GJ/Tonne (Steel 2014), it is clear that WHR for the CSSW should be explored further. A number of technologies were discussed and proposed but due to the complexity of the energy systems of a steel works it was difficult for the works to decide what to do with the recovered energy.

This was typical for UK industry and the barriers associated with the deployment of technology are discussed in the publication by the Energy Research Partnership 'Industrial Energy Efficiency Key Messages' (ERP 2011). The publication discusses the effect of a lack of strategy. Without a strategic plan Industry finds it difficult to justify and invest in and adopt new technologies.

The timing of this project was therefore very auspicious and so its aims and objectives developed into what became to research WHR further and then model its implementation. A WHR strategic plan could then be developed in an attempt to remove any foreseen barriers and increase the chance of project implementation.

2.9. Summary

This Chapter describes the Steel Industry and introduces the CSSW. The energy systems for CSSW are defined and the opportunity to investigate a WHR strategic plan is presented

This Chapter has described the steel making process and how its global production has increased as developing countries expand. The Chapter shows how China now accounts for both 45% demand and production of worldwide steel. In Europe demand and production has declined over the decades with the position in the UK particularly stark with over a 40% reduction in production and nearly a 50% reduction in demand since 1972.

The Chapter also introduces the CSSW and its recent journey into energy efficiency. Energy flows are determined and presented in Sankey format. Research identifies that the CSSW had recently been exploring WHR and had identified a potential recovery of 6GJ/T which at a SEC of 24GJ per tonne is a potential reduction in SEC of 25%. However, because of identified typical UK barriers to investment in WHR, the CSSW had not yet invested in this technology.

This Chapter has therefore completed aim 1 of the thesis by defining an energy efficiency technology that requires further research and modelling to aid potential implementation.

3. Industrial Waste Heat Recovery

3.1. Introduction

Chapter 2 has described energy use in the steel industry and highlighted Waste Heat Recovery [WHR] as a potential opportunity for the CSSW. This Chapter introduces the concept of WHR, provides a definition and describes technologies for its utilisation. WHR technologies are then defined for Industry in general and specifically for the UK Steel Industry. The headings 'Quantity', 'Technology' and 'End Use' are described for WHR in general and the steel industry in particular. The chapter then reviews the information from the studied literature and relates it to the CSSW.

3.2. UK Heat Supply

The UK Governments Department of Energy and Climate Change [DECC] has recently been exploring the subject of Heat supply and published the document 'The future of heating: A strategic framework for low carbon heat' (DECC 2012b). Working towards its 2050 Climate Change Targets, DECC states in its focus on Energy efficiency, 'the demand for Heat is fundamental to human society and always has been' (DECC 2012b). How best to generate that heat energy in every sector, that is, Industry, Commercial buildings, public buildings and domestic housing is explored and questioned in the DECC publication (DECC 2012b). How to supply that heat most efficiently and with the lowest carbon impact is questioned. It states that 80% of the Heat generated in the UK is done so via natural gas. With the UK now importing natural gas (DECC 2013a) this obviously has potential reliability and cost issues, as well as being Carbon intensive. DECC state that almost half [46%] of the final energy consumed in the UK is used to provide heat. The main other uses

of energy are split between transport [41%], electricity for lighting and appliances [8%], and a variety of other uses including agriculture and waste as shown in Figure 31.

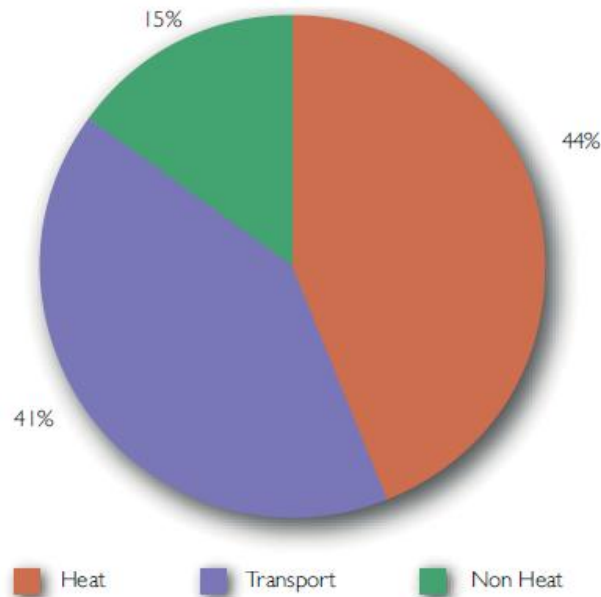

Figure 31 UK Split of Energy Consumers (DECC 2012b)

Figure 32 graphically demonstrates the relative energy demand between electricity and Heat for the UK (DECC 2012b). It can be seen that as expected heat demand is seasonally based, whereas, electricity tends to be reasonably independent of weather conditions. As can be seen in the figure the mean heat demand over the year is in the order of 130 GW of Energy. DECC (DECC 2012b) states that radical and drastic changes to the way that the UK functions will be required to Decarbonise the heat supply. DECC (DECC 2012b) discusses heat saving technologies for buildings and houses, District Heating networks and introduces the theoretical conceptual strategy for linking Heat sources together.

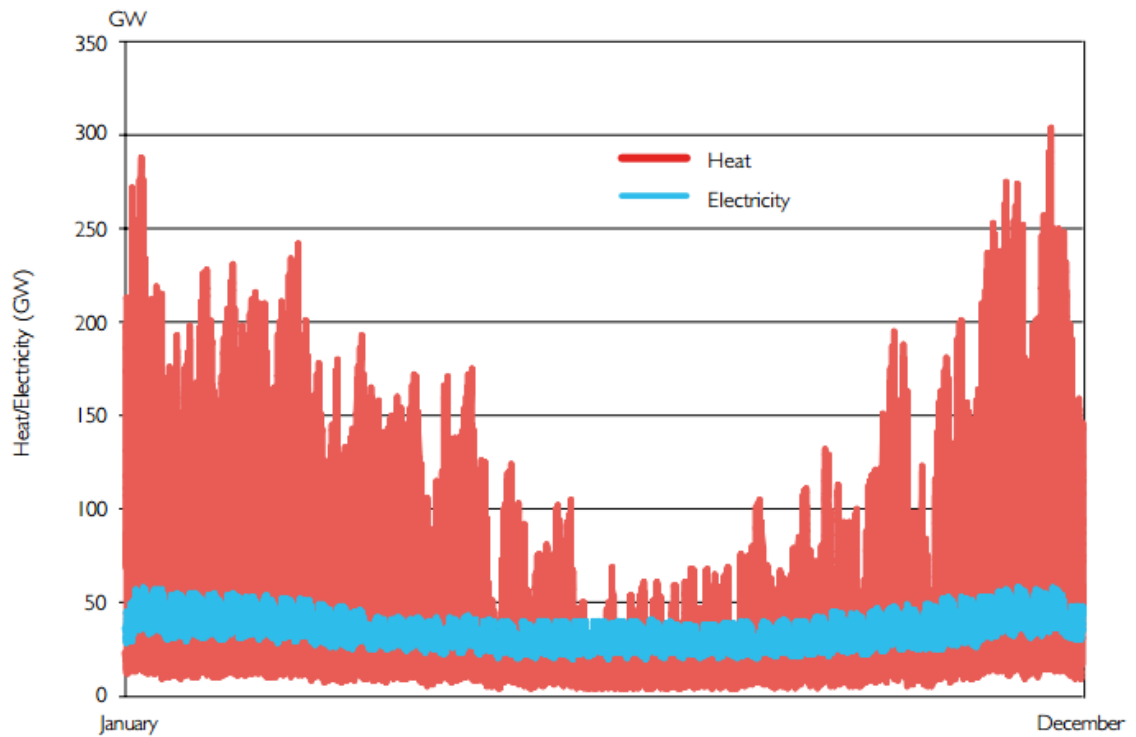

Figure 32 : UK Annual Energy Supply for Heating (DECC 2012b)

Figure 33 shows the breakdown of heat demand by sector. Adding up the Industrial heat demands gives a total of around 200 TWh. For Industry DECC (DECC 2012b) suggests focusing on efficiency, Combined Heat and Power [CHP] and low Carbon options for heat generation as well as further exploration of Carbon Capture and Storage [CCS]. For industrial energy efficiency improvements DECC (DECC 2012b) discusses WHR and give an example for the Steel industry where WHR is used to preheat combustion air to reduce Gas consumption for its oven. DECC's publication in 2014 titled 'The potential for recovering and using surplus heat from industry' (Energy 2014b) provides an overview of the opportunity of WHR to UK industry and in fact in its Appendix (Energy 2014a) an output from this PhD project is referenced as a case study for the UK Steel Industry.

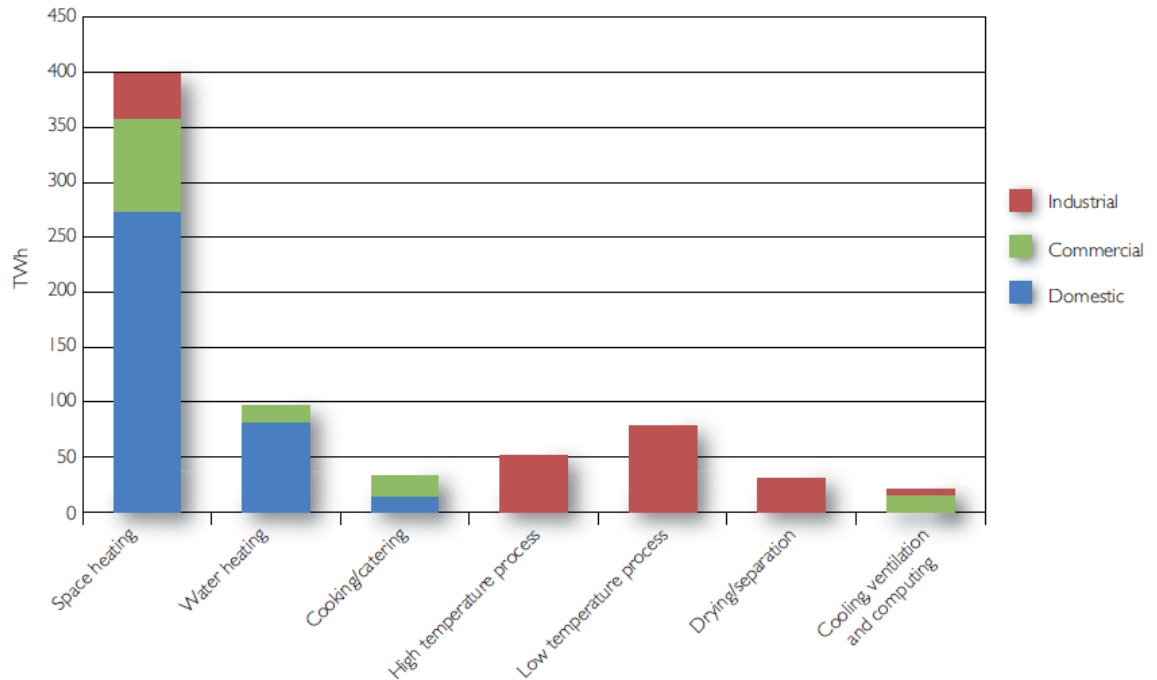

Figure 33 UK Split of Heating Demand (DECC 2012b)

According to the US Department of Energy (USDoE 2008) the exact quantity of industrial waste heat is poorly defined but state that various studies have estimated that as much as 20-50% of industrial energy consumption is ultimately discharged as waste heat.

Referring back to Figure 33, and the deduced 200TWh of industrial heat consumed in the UK, and applying the USDoE statement, that typically 20-50% of heat is discharged as waste heat, it is possible to deduce that somewhere in the region of 40-100TWh is emitted as industrial Waste Heat in the UK. Therefore, justifying the requirement for future research into the application of WHR for UK industry.

3.3. Waste Heat Recovery [WHR]

The US Department of Energy state captured and reused waste heat is an emission free substitute for costly purchased fuel or electricity (USDoE 2008). United Nations Energy Efficiency Guide for Asia (UNEP 2006) states that if some of the energy lost from the large quantities of hot waste gases from boilers, kilns, ovens and furnaces then considerable

amounts of primary fuel could be saved. The Carbon Trust also include waste heat from buildings in their overview of the subject (Carbon Trust 2014) demonstrating the more recent focus on all sources of WHR potential. Gent gives a good overview of the subject matter (Gent 2010) that including the various technologies available and provides case study examples. Its opportunity for WHR in UK Industry has been recently defined and modelled (Energy 2014b), as well as quantifying the potential (McKenna 2009b) and provide overviews of waste heat recovery. The theory, possible technologies and barriers for implementation are also highlighted.

As explained by BCS Inc (USDoE 2008), *‘Industrial waste heat refers to energy that is generated in industrial processes without being put to practical use. Sources of waste heat include hot combustion gases discharged to the atmosphere, heated products exiting industrial processes, and heat transfer from hot equipment surfaces’*.

Waste Heat arises from system inefficiencies and/or simply as the result of a defined process. For example if a component has to be heated up to 800Deg C, for annealing, then during the cooling process all the heat will be lost or wasted. Some heat could be used to preheat the combustion air, to improve the efficiency of the ‘heating process’, but inevitably some will be wasted to atmosphere. According to the Energy Management Handbook (Turner and Doty 2006) *“Waste heat is that energy which is rejected from a process at a temperature high enough above the ambient temperature to permit the economic recovery of some fraction of that energy for useful purposes”*. As previously stated by the US Department of Energy, the exact quantity of industrial waste heat is poorly quantified, but various studies have estimated that as much as 20 to 50% of industrial energy consumption is ultimately discharged as waste heat (USDoE 2008).

As part of an EPSRC project ‘Thermal Management of Industrial Processes National sources of low grade heat available from the process industry Progress Report 2011’(Newcastle University 2011), Newcastle University state that in July 2006, the market potential for surplus heat from industrial processes in the UK was estimated at 144PJ by the Carbon Trust (Carbon Trust 2014) and more recently at 65 PJ by the Government’s Office of Climate Change (BERR 2008) and 36-71 PJ by McKenna (McKenna 2009a). These numbers differ so much because of the difficulty in obtaining reliable data. The higher grade waste heat sources in UK industry have been known about for decades, but data for the lower grade heat sources is only recently becoming more available. This is primarily due to business and industry’s recent focus on energy efficiency and the recent technological advances in ORC and heat pumps. In order to understand their processes Industry has therefore had to develop a greater understanding of their operation, control and how energy is used within the various cycles.

Re-using the heat locally is usually the optimum solution rather than having to transport the energy elsewhere, with associated losses. Therefore improving combustion efficiency, by preheating the combustion products or in the case of a boiler, preheating the feed water can save significant quantities of energy. The US Environmental Protection Agency [EPA] gives examples of WHR saving up to 50% fuel use by using recuperators with a Kiln (USEPA 1998). The EPA also state that some form of industrial waste heat is inevitable, however, in today’s climate of increasing energy costs, the challenge is to maximise the potential of the waste heat energy availability. Waste heat is traditionally used for preheating combustion air, generating steam for electricity generation, absorption cooling and space heating. Many of these technologies are well established and proven but newer technologies, such as heat pumps and Organic Rankin Cycle units [ORC] are providing a

greater challenge for industry. These newer technologies are not well used and offer a perceived risk to industry. As there is a choice of technologies for specific industries it is therefore imperative that a proper decision making process is followed. All options need careful consideration for their suitability and modelling used to ensure the most accurate assessment. To assist Industry the US Department of Energy (USDoE 2008) suggest the use of three headings to guide investigations and state the fundamental questions in the investigation into the use of WHR are:-

- a) what is the 'quantity' of heat energy available,
- b) the potential 'technology' that can be used to harvest the energy and
- c) the 'end use' application.

This thesis utilises these key strands repeatedly to help explain the investigation process. Therefore, 'Quantity', 'Technology' and 'End Use' of WHR is further explored.

3.4 Quantity

As defined by United Nation Environmental Program [UNEP] (UNEP 2006), to calculate the quantity of energy available from the waste stream the equation can be used;

$$Q = V \times \rho \times C_p \times dt \quad \text{Equation 1}$$

Where:

Q= the heat content in J/hr

V = the flow rate of the substance in m³/hr

ρ = in the density of the flue gas in kg/m³

C_p = is the specific heat of the substance in J/kgK

dt = is the temperature difference in K

The main factor that affects the quality of the waste heat available is temperature. Generally speaking the higher the temperature the more 'valuable' the waste heat source. With higher temperatures it is possible for example to generate high pressure superheated steam that can be used for electrical generation. This is not possible with lower temperature waste heat sources directly but with newer developing technologies this may soon be the case.

Historically it has not been possible to recover energy from low temperatures sources but with developments in heat pumps, for example, it is becoming more viable. There are no fixed definitions of the quality of waste heat. It tends to be classed as High, medium or low, for example the US Department of Energy uses (USDoE 2008):-

High Grade Waste Heat is 650°C and higher

Medium Grade Waste Heat is 230°C to 650°C

Low Grade Waste Heat is 230°C and lower.

It is of course possible to utilise Exergy values to help assess and categorise waste heat sources (Wall 1986). The Exergy value can be calculated to help assess the 'value' of the waste heat stream. The exergy concept defines the 'quality of an amount of energy in relation to its surroundings that is expressing the part that can be converted into work'. It is based on the fact that the entropy of an isolated system never decreases [ie the second law of thermodynamics] (Wall 1986).

$$E = dH - T_o \times dS \quad \text{Equation 2}$$

Where E = Exergy,

dH and dS are the changes in enthalpy and entropy from the reference state [the surroundings] and

T_o = the absolute temperature at the reference state [Kelvin].

When considering quantity one must also consider the available energy profile of the waste heat source. For example is the process that produces the waste heat continuous or batch? Does it vary in terms of temperature and flow rate? These questions need to be understood when assessing the options and therefore it's critical that accurate data analysis is conducted to ensure an accurate 'value' of the waste heat source is determined.

To link the quality aspect and the end use, it would be best practice to conduct what is known as a Pinch Analysis for the process (Kemp 2007). The 'Pinch Analyses' process thermodynamically studies heating and cooling cycles looking for a thermally optimised solution with limited numbers of energy exchangers thus saving energy (Kemp 2007). This would help identify the local heating and cooling processes and ultimately lead to the optimum end use for any waste heat application. Larson conducts a Pinch analyses for a steel works as a whole, concluding with some good potential theoretical energy savings however Larsson also concludes that the gap between theoretical possibilities and practical application will require further work (Larsson 2004) and more recently Isaksson provides a more up to date example (Isaksson et al. 2011). Due to the fact that there are relatively few streams, Isaksson concludes that, although the pinch analyses technique is of use for some of the sub sections, it is not suitable when studying a steel works. It is therefore concluded that this type of analysis would not add value to the current study.

3.5 Technology

The Waste Heat Energy Efficiency Guide for Industry in Asia (UNEP 2006), provides details of the most commonly available technologies for capturing this form of energy. The Carbon Trust publication 'Waste Heat' (Carbon Trust 2014) also provides examples of

differing technologies employed for WHR. This section briefly summarises these technologies which can be further explored through the quoted references (UNEP2006,Carbon Trust 2014). They are in effect ‘heat exchangers’ and can be categorized under the following headings:

3.5.1 Recuperator

A recuperator usually uses a counter-flow energy recovery heat exchanger. As the waste gases pass one way through the exchanger, the medium to be heated, passes in the other. That way heat is simply transferred from the hotter waste gas to the cooler medium flow.

3.5.2 Metallic radiation Recuperator

The radiation recuperator uses parallel flow and usually used when there is a requirement to cool the waste gas ducting to extend its service life. These are not as efficient as counter flow systems, but serve the cooling purpose and provide energy recovery. They are the simplest type of recuperator and because it utilizes radiant heat transfer, from the hot gas to the surface of the inner tubes. Convective heat transfer takes place though between the tubes and the cold air flow.

3.5.3 Tube or Convective Recuperator

Perhaps the most popular type, the tube recuperator, utilises a counter-flow design, passing the cooler medium over tubes which contain the hotter medium. Baffles guide the cooler medium around the tubes in a number of passes. The number of baffles defines the number of passes. For example a three pass recuperator would have two baffles. The higher the number of passes the more effective the heat exchange

3.5.4 Hybrid recuperator

Combining Radiant and convective techniques together improves the effectiveness of heat transfer. Radiation exchange takes place followed by the convective system.

3.5.5 Ceramic recuperator

To extend the operating limits of the recuperators above 1100 °C ceramics are sometimes used instead of a metal matrix. The principal limitation on the heat recovery of metal recuperators is the reduced life of the liner at inlet temperatures

3.5.6 Regenerators

Used extensively in the steel and glass industry regenerators are designed for significant gas flows. Blast Furnace Stoves being a relevant example as shown in Figure 34. The stoves are shown preheating the hot blast on its way to the Furnace. The stoves are refractory lined domes which are preheated by combusting a gas. The combustion is then stopped and the Blast is then blown through the stoves taking heat out of the refractory. When cool the stove is then reheated. It is usual to have a number of stoves all in different thermal cycle stages. The number, size, refractory type, thermal input and changeover time therefore depict the amount heat transfer.

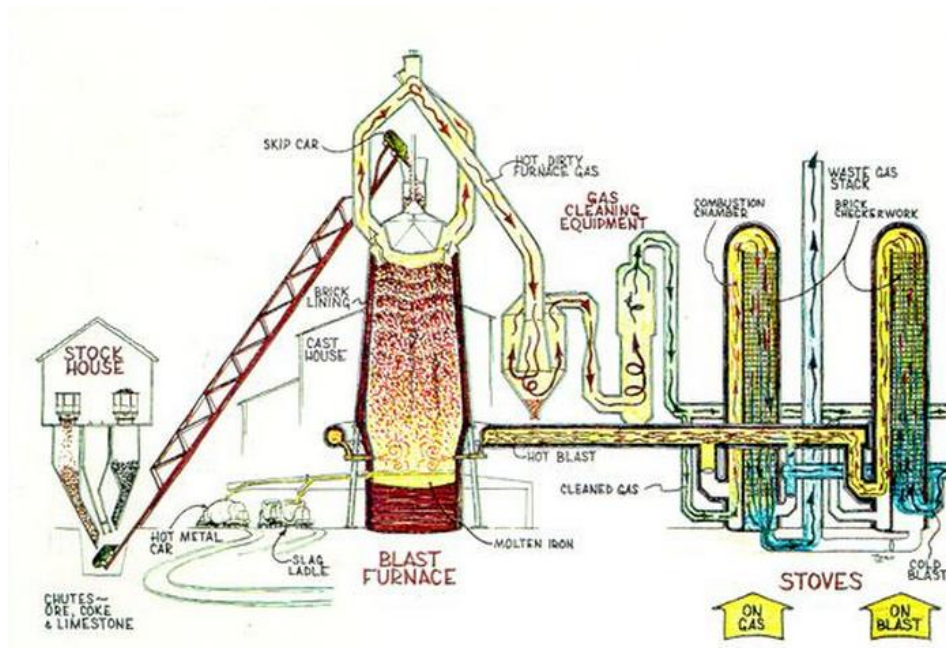

Figure 34: Schematic of Blast Furnace regenerative stoves (AISI 2014)

3.5.7 Heat Wheels

The heat wheel is used mainly in building air conditioning systems. The wheel is a thermal disc that spins slowly with one side in the hot stream and the other in the cold stream. The wheel gets heated up on the hot side and then cooled down on the cold side, thus transferring heat across streams. It's used for applications with small temperature differences but relatively high volumetric flow rates.

3.5.8 Heat Pipes

A heat pipe is made up of a sealed container with an integrally fabricated wick structure and a working fluid. As one end of the heat pipe is subject to thermal energy so the working fluid at that end boils, using the latent heat of evaporation to form a vapour. As the vapour travels to the opposite end, the thermal energy is removed causing the vapour to condense into liquid, thereby giving up the latent heat, so this end of the heat pipe works as the condenser region. A heat pipe can transfer up to 100 times more thermal energy than

copper. In other words, a heat pipe is a thermal energy absorbing and transferring system. Almost like the Heat Wheel concept, heat Pipes are used to transfer heat from one stream to another, for example Space Heating. The heat pipe transfers the thermal energy from the exhaust for building and preheats the incoming air. Another application is where heat pipes can be used for preheating combustion air using the exhaust stream from a furnace with one end of the heat pipe in the exhaust stream and the other in the combustion air stream.

3.5.9 Economizers

To improve the efficiency of a boiler it is common to use waste heat, through an economizer, to preheat the feed water thus saving fuel.

3.5.10 Shell and Tube Heat Exchangers

The shell and tube heat exchanger is used when the medium containing waste heat is a liquid or a vapour which heats another liquid. Both paths must be sealed to contain the pressures of their respective fluids. The shell contains the tube bundle and internal baffles to direct the fluid over the tubes in multiple passes.

3.5.11 Plate Heat Exchangers

The plate type heat exchanger consists of a series of separate parallel plates forming a multiple layered sandwich. Each of the plates is separated by a seal. The hot stream runs through alternate rows of the plates and the cold stream through the other plates this forming a sandwich of flows.

3.5.12 Run Around Coil Exchangers

A “run around coil exchanger” is in effect two heat exchangers connected together with a transfer fluid system. One heat exchanger is in the waste heat stream and the other in the stream that needs to be heated. This technology is effective when the waste heat source and

cold source are some distance away from each other. The transfer fluid can be selected and well insulated to limit temperature loss.

3.5.13 Heat Pumps

Due to technological improvements and increased COPs [Coefficient of Performances] these systems are becoming economically viable for industry, with the capability of using heat pumps to take industrial cooling tower water up in temperature from 35°C to the 85°C required for building heating systems. With Tax incentives such as the UK Governments Enhanced Capital Allowance [ECA] (GOV.UK 2015), heat pumps are becoming more financially attractive to industry.

3.5.14 Waste Heat Recovery Boilers

Waste heat boilers are the traditional water tube boilers. Hot exhaust gases pass over a number of parallel tubes containing water. The water is vapourised in the tubes and collected in a steam drum from which it is drawn out for use as heating or processing steam. As shown in Figure 35 as the flue gases are exhausted they pass over water tubes, boiling the water that is then evaporated to form steam from the steam drum. This is sometimes referred to as evaporative cooling.

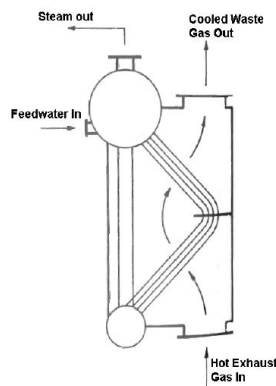

Figure 35 Section Through a WHR Boiler (USDoE 2008)

3.5.15 Developing technologies

Particularly for lower grade waste heat recovery, newer technologies are developing and becoming more commercially viable. These include heat pumps, Organic Rankin Cycles, Kalina Cycles and Manchester Universities paper (Manchester University, 2010a) includes thermoelectric technologies which convert heat energy directly into electrical energy using a series of semiconductor thermocouples .

3.6 'End Use'

The 'End Use' really means 'what is going to be done with the recovered energy?' For example one could calculate the heat quantity and quality from a waste heat stream, then find a technology to capture that waste heat and generate steam for example. For a successful project one needs to ensure that an 'End Use' is readily available or one needs to be provided. Selecting the optimum end use can be complex and requires knowledge of the process in question and potentially adjacent processes, thus utilising the energy close to source is optimum. Having to transfer the energy away to another process can be inefficient and expensive. The profile of the end use heat demand is also important. For example building heating is only used during the day and during the winter months. This needs to be understood thoroughly when the options and project costing are calculated.

3.7 Barriers to WHR

Holman (Holman 2011) summarises barriers for the implementation of WHR in United States [US] industry and discusses the risks of the technological change to industrial processes, over running capital costs and variability of electricity market price as the main industrial barriers. Holman defines how government incentives, technological improvements and new business models can potentially improve the situation going

forward. Companies are becoming more able to arrange finance agreements, instead of having to find capital for the required investment, thus reducing risk through partnership with a potential electricity 'buy back' deal. This reduces the financial risk on industry from, over running capital and variability in electricity prices, but will still leave the technological risk of the WHR process negatively affecting the industrial process to be managed. The BCS document (USDoE 2008) lists barriers in the US to the uptake of WHR projects highlighting resource, cost, risk, long payback, available technologies, inaccessibility, temperature and chemical constraints.

The International Finance Corporation [IFC] and the Institute for Productivity [IIP] (IFC and IIP 2014) explain the regulatory drivers introduced in China to promote the adoption of WHR in the Cement Industry. China's 'Energy Conservation Law of the Peoples Republic of China', items 31 and 78, enforce energy efficiency and the Ministry of Industry and Information [MIIT] have introduced legislation that all new production lines will have to be equipped with low temperature waste heat to power technologies. Within Europe Forni et al (Forni et al. 2012) gives an overview of Italian industrial WHR opportunities. Italy is one of the only countries in Europe to incentivise the adoption of WHR technologies. Forni et al (Forni et al. 2012) discussed the cement, glass, oil&gas and steelmaking industries in particular the growing application of ORC for low grade WHR due to the governmental incentive.

In the UK Norman (Norman 2013) identifies lack of information as well as the focus on Production, lack of staff time and short payback times as additional barriers. UK drivers are primarily to save money, reduce CO₂ and reduce electricity dependence due to the UKs

potential future security of supply as described in Chapter 1. There are no government incentives in the UK despite extensive lobbying by industry.

DECC (DECC 2013b) break down the barriers into Commercial, Delivery and Technical. DECC also list the UK regulatory measures to assist, as discussed in chapter 1, that is, the European Union Emissions Trading Scheme [EUETS], the Climate Change Levy [CCL], Climate Change Agreements [CCA], CRC and state the potential for the Renewable Heat Incentive [RHI] to incorporate industrial waste heat.

Manchester University publication 'Addressing the barriers to utilisation of low grade heat from the thermal process industries' (Manchester University 2010a) describes the outcome of a project and workshop to understand the perceived barriers that business and industry see when trying to adopt WHR projects. The paper states that participants at the workshop prioritised the key barriers as lack of infrastructure, capital cost and location.

Communication, awareness, the suitability of end users and technology were recurring themes. Figure 36 shows the outcome of the project, that is, a map grouping and showing the perceived barriers. This is done in an attempt to help develop a future work program to assess these barriers and help promote the uptake of WHR projects in Business and Industry.

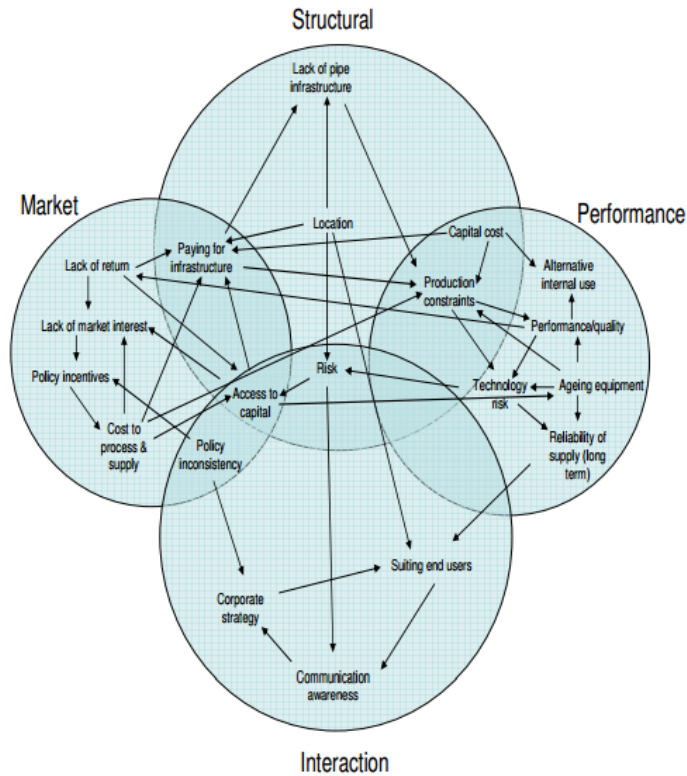

Figure 36: Mapping of Barrier Linkages (Manchester University 2010b)

3.7 Heat Recovery in the steel industry

Waste Heat Recovery in the Steel Industry is not new. The book ‘The effect of the various steelmaking processes on the energy balances of integrated iron- and steelworks ‘ (Group 1961) published back in 1961 includes sankey diagrams of the steel making processes.

Waste heat is clearly identified and technologies for its recovery are discussed. As discussed in Chapter 1 section 6, in publications such as ‘Energy use in the steel industry’ (IISI 1998) and ‘Future technologies for energy efficient iron and steel making’ (deBeer et al. 1998), WHR is highlighted as key to any energy reduction plan for a modern steelworks. As previously shown in figure 1.14 five of the top fourteen energy reduction technologies are WHR. McKenna (McKenna 2009a) calculated the potential for WHR within differing

industrial sectors of the UK and as shown in Figure 37, the Steel Industry has the largest potential in the UK. The steel industry was identified as the largest user of heat with a heat load of approximately 213 PJ, but also has the highest potential for WHR. Clearly identifying the opportunity for the industry to potentially reduce its energy import and explore.

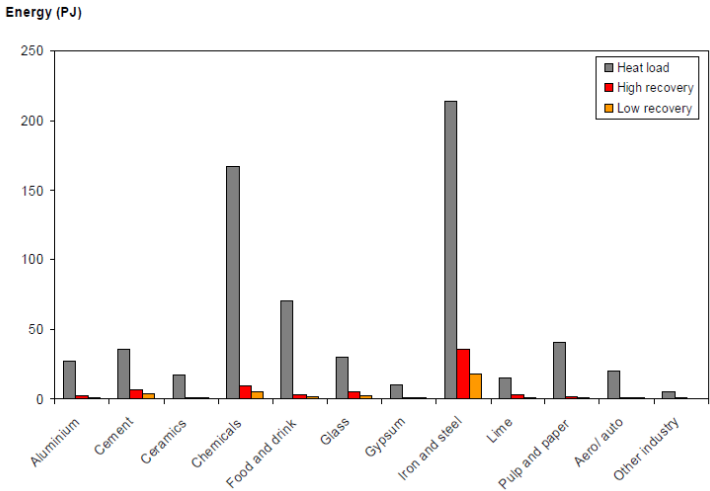

Figure 37: Energy use for heat [heat load] and estimated recovery potentials for industrial sectors (McKenna 2009a)

As discussed by DECC, there are many potential sources of waste heat for UK industry to exploit (Energy 2014b, a). Figure 38 shows how the Element Energy changes the graph of potential WHR for differing industries. Considering a factor for economic payback significantly changes the output and is a reminder that theoretical potential is only part of the picture. This also implies that WHR projects for the steel industry have longer paybacks and thus more difficult to build a business case.

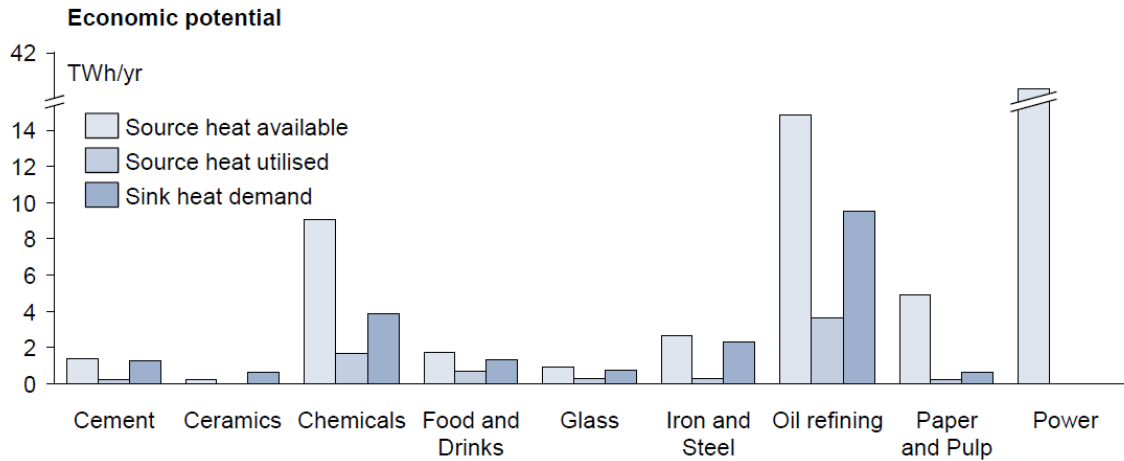

Figure 38: Economic Potential of UK WHR potential (Energy 2014a)

Newcastle University (Newcastle University) has developed energy diagrams for the steelmaking process. Figure 39 shows an example diagram for the BOS process with the waste heat streams identified and quantified. The energy [MW] available from the various sources is shown. It should be said though that the energy available from the BOS exhaust gas is too low for any viable recovery. As defined by Kasalo (Kasalo 2010) in BOS gas WHR, the energy available from the hot waste exhaust is around the 100MW, however there are differences in how this value was there are differences in how this value derived. If a BOS plant off [exhaust] gas system is currently cooled by water via a cooling tower. The analysis of the heat energy contained by either considering the 35 °C rise in cooling water temperature or by taking a step back and analyse the heat energy contained in the 1700 °C off-gas stream. This temperature difference obviously presents a contrasting picture for the exergy value of the waste heat stream, but it also affects the available technology and the choice of the optimum ‘end-use’. That’s why it’s imperative that the full process is understood in detail to ensure that the full potential gain is identified. The key factors of ‘Quantity’, ‘Technology’ and ‘End Use’ for the steel industry will be identified.

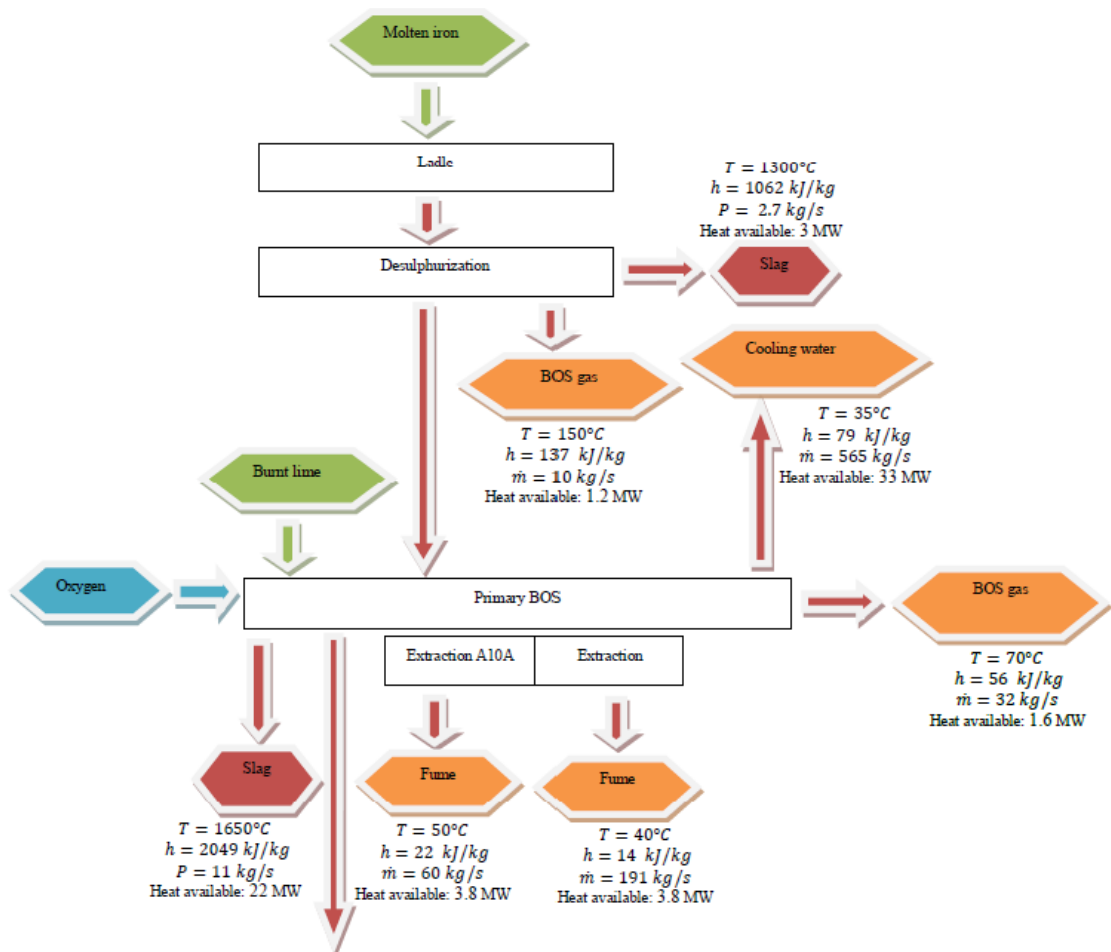

Figure 39 Steel Industry Waste Heat Schematic (Newcastle University)

3.8 Quantity

As shown in Figure 40 the steel industry has relatively large potential for WHR. Zhang et al (Zhang et al. 2013b) graphically present the higher grade waste heat sources as highlighted in Figure 40 and shows that the majority of waste heat is emitted from the product itself. This will be from the molten iron as it is transported to the BOS plant, the liquid steel as it is transported to the Continuous casting plant [concast], the hot slab as it is transported to the hot mill and the hot rolled coil as its waiting for cold rolling. The other large possibilities are waste heat from the slags discharged from the Blast Furnace and BOS

plant operations. These are significant quantities of waste heat, but there are no examples of its full scale industrialised WHR. The waste gas segment, representing 10% in Figure 40, is where most of the current WHR technology is aimed. Figure 40 is for high grade waste heat and does not include low grade waste heat which is covered later in this chapter.

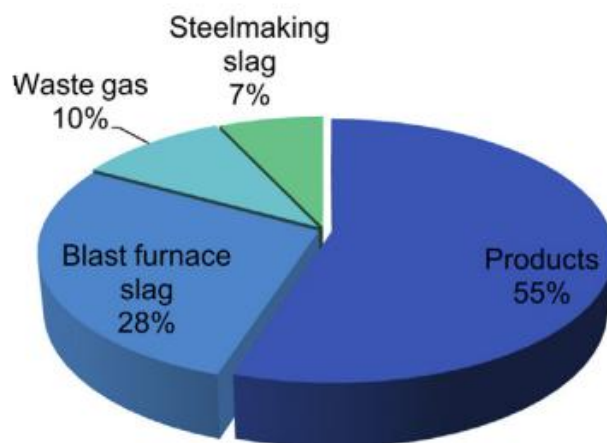

Figure 40 High Grade Waste Heat Availability (Zhang et al. 2013b)

Table 1 shows examples of the WHR potential in the steel industry (Energy 2014b). As can be seen WHR from slag, steel and waste gases is listed and its potential calculated in terms of kWh/Tonne and temperature. It should be noted that the Sinter Plant was omitted from the analysis by the authors (Energy 2014). As will be defined later in the chapter the Sinter plant is a major WHR source. The table suggests that up to 8.46GJ/T of WHR can be achieved. Allwood and Cullen (Allwood and Cullen 2012) quantify the amount of waste heat globally emitted from the steel industry as shown in Figure 41, as shown typically 4EJ of recoverable exergy has been identified. The figure shows a 40 EJ input to the process and the division of Exergy to produce the end product. What is clear is that 7 EJ is retained in the product itself, with 4 EJ able to be recovered and 29 EJ lost. That is 10% of the input Exergy can be regarded as recoverable. Thus for a global steel make of 1,572MTPA (WSA 2014) this equates to a potential specific energy reduction of 2.5GJ/T. The figure

demonstrates the large amount of recoverable energy from Coke Making, Steel Making and Hot Rolling and as highlighted in Table 1, only identifies the higher temperature waste heat sources.

Table 1: Example Steel Industry WHR Potentials (Energy 2014a)

		Heat Source	Heat supply Kwh/T	Temp Degrees C
Coke Ovens	Sensible Heat in the Coke Ovens	Gas	82	980
Coke Ovens	Exhaust gas from combustion of CO gas	Gas	58	200
Coke Ovens	Heat Recovery from solid radiant coke	Solid	62	800
Blast Furnaces	Sensible heat in the blast furnace	Gas	28	100
Blast Furnaces	Exhaust gas from blast stoves	Gas	82	250
Blast Furnaces	heat recovery from slag	Solid	100	1300
BOS	Heat recovery from BOS gas	Gas	141	1700
BOS	Heat recovery from BOS slag	Solid	6	1500
EAF	Electric Arc Furnace	Gas	44	1200
Casters	Heat Recovery from hot slab	Solid	352	1600
Hot Rolling	Heat recovery from coil	Solid	1395	400
		Total	2,350	KWh/Tonne
			8.46	GJ/Tonne

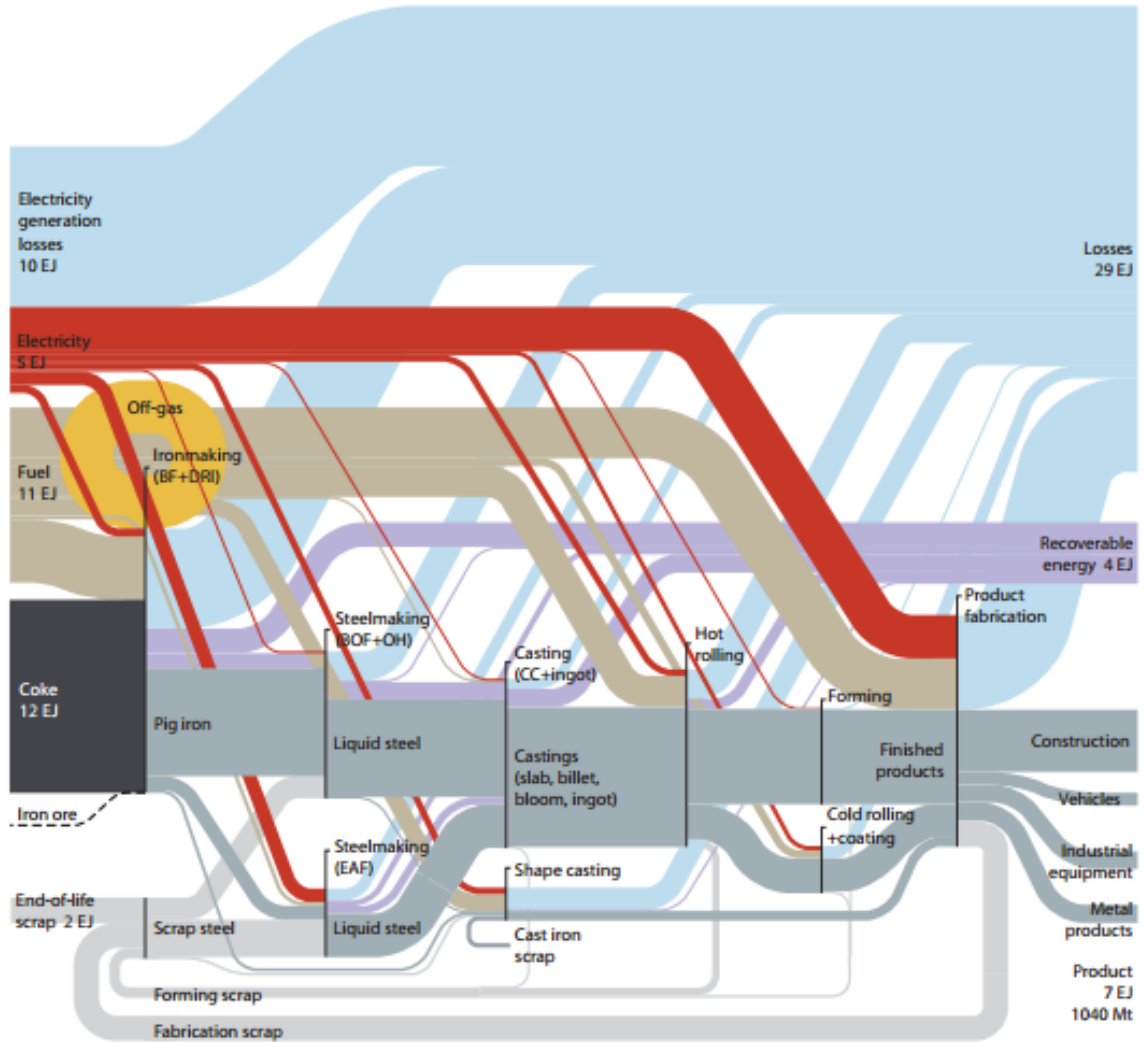

Figure 8.11—Global exergy flow for steel

The key message of these two diagrams of exergy flows is that energy used in the downstream part of the process, supplied as electricity, does work and is converted to low temperature heat with which we can do very little. However, the energy lost in the earlier part of the supply chain as heat at higher temperatures has significant remaining exergy value—and we'd like to exploit it.

Figure 41: Global Exergy flow for Steel (Allwood and Cullen 2012)

Table 2 shows the lower grade waste heat potentials, as calculated by Newcastle University (Newcastle University). The table tabulates the sources by location, type, quantity and energy value. Totalising the energy values for both gas and water streams gives 31.59 MW or about 1 PJ/Year. For example, a steel works producing 4.5 Million Tonnes Per Annum

[MTPA] year of steel, the low grade waste heat potential equates to approximately 0.22GJ/T.

Table 2: Low Grade WHR Potentials (Newcastle University)

Location	Type	T _{out} °C	Quantity Kg/s	Energy MW
Cold Mill Leveller	Streach leveller extraction fume	30	12	0.002
Cold Mill and Pickle line	Extraction Gas	40	22	0.014
BOS Primary	Hot metal pouring fume	50	60	0.088
BOS Secondary	fume	50	86	0.125
BOS Primary	BOS gas	70	32	0.125
BOS Primary	Hot metal pouring fume	40	191	0.126
BF a	flare BF gas	200	3	0.148
BOS Primary	Desulphurisation gas	150	10	0.229
Cast House N	fume	50	185	0.27
Cast House S	fume	50	185	0.27
Sinter Dedust	sinter gas	50	245	0.36
BF b	flare BF gas	200	10	0.443
End of Sinter Strand	sinter gas	180	36	0.734
Ammonia incinerator	NH3 combustion gas	210	10.75	0.827
Coke Oven Gas underfiring	mixture of BF and CO gas	220	100	5.128
Main stack	sinter gas	130	388	6.666
Power Plant Bleed off	water vapour			
Sinter breaker bar	Cooling Water	50	9	0.016
BF gas wash	Cooling Water	41	257	0.311
Hot Mill Reheat B	Cooling Water	38	233	0.337
Hot Mill Reheat A	Cooling Water	38	218	0.353
BF a gas wash	Cooling Water	35	307	0.466
Caster 3	Cooling Water	40	200	0.535
Hot Mill run out table	Cooling/quench water	35	444	0.599
Caster 3	Cooling Water	33	542	0.62
BF a open cooling	Cooling Water	35	665	0.651
copperwork BFb	Cooling Water	40	1405	0.701
Tuyere (bf)	Cooling Water	37	417	0.81
BOS Primary	Cooling Water	35	565	0.824
open cooling BF b	Cooling Water	36	511	0.882
Caster 1	Cooling Water	42	316	1.019
Caster 2	Cooling Water	40	486	1.296
Caster 1	Cooling Water	40	495	1.32
Caster 2	Cooling Water	40	497	1.32
Coke Oven	Main recirculating cooling water	40	556	1.518
Hot Mill	dirty water return	35	1827	2.457

Total = 31.59

Patsos in his paper (Patsos 2012), states that a single typical UK based integrated steel plant releases approximately 30-35PJ/y of waste heat to the environment in either gaseous, liquid or product form [excluding losses from structures or buildings]. As shown in Table 3 (Patsos and Mullan 2011) a total of 8.68GJ/tonne in available energy and 1.69GJ/T of

Exergy. This difference in relative magnitude is partially explained by the relatively large quantity of low grade waste heat available from the steel works. The study (Patsos 2012) showed that heat losses from cooling water around an integrated steelworks can exceed 4.5 GJ/T, whereas waste heat from combustion stacks can exceed 1.5 GJ/T. This highlights areas of high-grade waste heat which include coke heat losses at 1.4 GJ/t coke and Blast Furnace and BOS plant slag where heat losses account for 1.4 GJ/t and 2.0 GJ/t of slag respectively.

Table 3: Energy and Exergy Potentials (Patsos and Mullan 2011)

<i>Source</i>	<i>Energy</i>		<i>Exergy</i>	
	<i>GJ/tcs</i>	<i>PJ/y</i>	<i>GJ/tcs</i>	<i>PJ/y</i>
Cooling water	4.63	19.45	0.16	0.67
Solid	2.21	9.28	1.17	4.91
Waste gas	1.53	6.48	0.34	1.43
Extraction gas	0.31	1.30	0.02	0.08
Total	8.68	36.51	1.69	7.09

Table 1: Summary of waste heat and heat exergy losses from an integrated steelworks

Due to the variability of steel works configurations globally it is understandable that there are considerable variation in the quantities of WHR potential available. However Patsos and Mullan’s work (Patsos 2012) was based on a case study of a UK steel works and thus most representative. However, for the BOS plant, the study has identified the cooling water rather than waste off-gas for the BOS plant available exergy value. The off gas is circa 1500°C and therefore would in fact have a significantly higher Exergy value thus demonstrating the importance of understanding the whole waste heat energy stream and not just focussing on the end product of the waste heat stream which is predominately the cooling tower. It is important to track the waste heat stream back to its source and asses if the exergy can be extracted at a higher temperature.

3.9 Technology

For available technologies to capture the waste heat highlighted in Table 1 and Table 2 then one needs to refer to the standard sources for the industry called the Best Available Techniques [BAT] Reference Document for Iron and Steel Production, known as the BREF document, (EC 2013b) and the (EPA 2012) as well as that indicated in Chapter 1, section 1.6, Figure 14 (EC 2012). These sources discuss and suggest WHR technologies for the iron and steel industry. Examples are provided for actual installations and the expected energy benefits stated.

Analysing some of the main steel industry equipment suppliers it is possible to see what 'off the shelf' technologies are available. For example, Figure 42 shows a presentation slide by Siemens VAI Metals Technologies GmbH (GmbH 2014) clearly showing their technologies available for WHR. The figure highlights technologies available for various parts of an example Integrated steel works. Oschatz GmbH, another supplier, highlights an example for a BOS plant (Oschatz 2012) and Kasalo in his paper (Kasalo 2010) describes BOS plant gas cooling options. The economics of selecting the WHR option called an Evaporative Cooling system is discussed by Kasalo (Kasalo 2010) who introduces the technology and states that it utilises the thermal energy present in the off-gas to create volumes of steam for export. Other suppliers also make bespoke WHR equipment specifically for the iron and steel making process. Other technologies can be employed, as summarised in section 3.3.b, that are not bespoke but can be engineering to recover waste heat from various streams for example existing waste gas stacks.

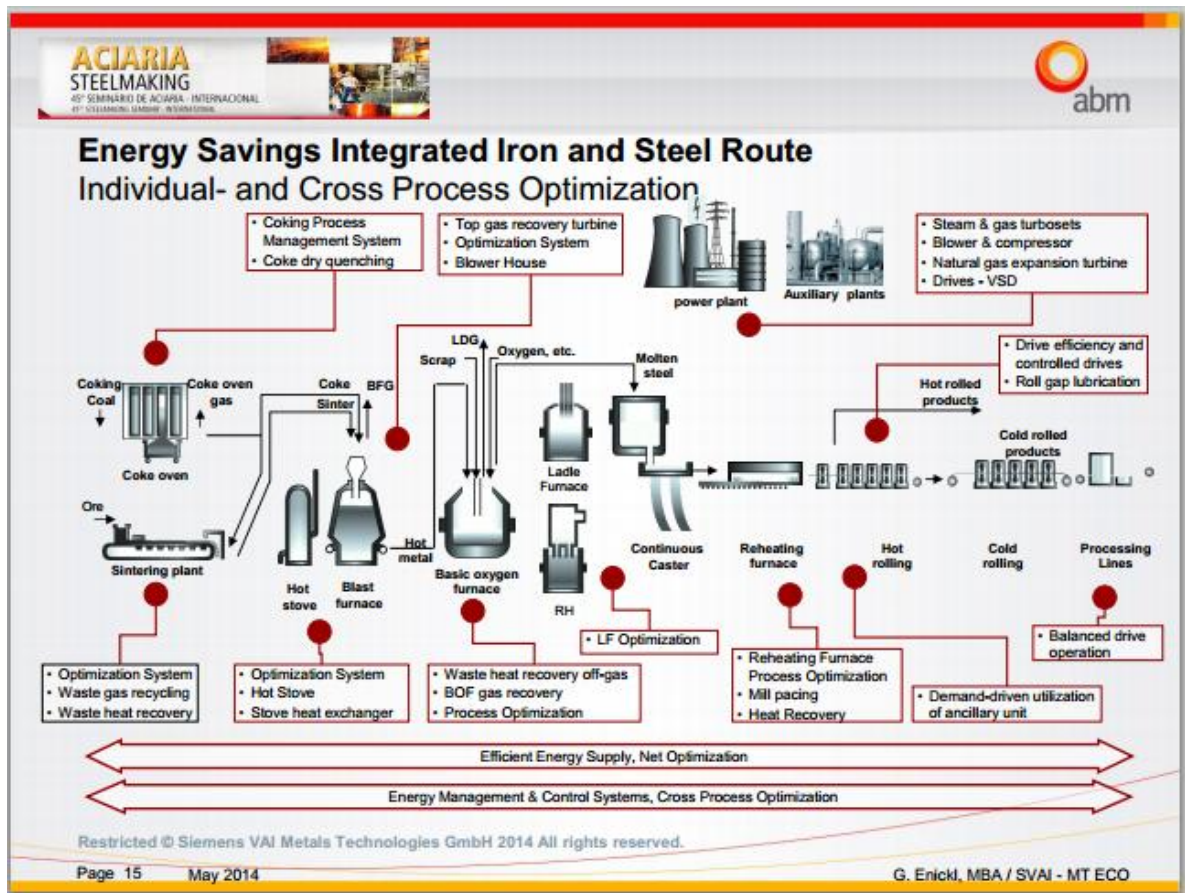

Figure 42 Example WHR Installations (GmbH 2014)

Referring back to Figure 40, which shows that there is potential for WHR from both the product and the by-product slag, WHR is not commonly practiced due to the inherent difficulty. WHR from Blast Furnace and BOS Slag does not yet have a fully commercially available technology. As discussed by Zhang (Zhang et al. 2013b) heat recovery from slag has been attempted since the early 1970's. Several options and technologies exist but have not been successfully implemented due to slag consistency and high energy running costs. Due to the inability to successfully install a slag WHR unit, laboratory experiments have been undertaken to produce hydrogen utilising the heat from the hot slag (Purwanto 2006). WHR from the product is also an area not commonly applied. The focus has been on limiting heat loss from the product ensuring it retains its heat for the next process. For

example the use of lids for the transport of molten iron to the BOS plant. Another example is the so called ‘hot connect’ and storing the slabs in ‘hot boxes’ is then practiced between the continuous casters and the hot mill, however scheduling restraints severely limit effectiveness of this practice. Again there are no commercially available options for utilising waste heat from the cast slabs, although there are some developments underway with manufacturers but as yet no commercially available (Siemens GmbH 2014). It is then common practice for steel works to quench coils prior to cold rolling. All the energy from the hot rolled coil is then transferred into the cooling water which is vented to atmosphere via a cooling tower. This process downgrades energy from hot coil at 200 °C to low grade waste heat within the cooling water.

WHR from gas streams is where the majority of the technology exists. As shown in Figure 42 technologies are available for waste gas streams from the Coke Ovens, Sinter Cooler, BOS Gas and the Hot Mill reheat furnace.

3.10 ‘End Use’

The optimum end use for the recovered energy differs for each steelworks depending on where they are in their waste heat recovery maturity. Some will have spare capacity in their steam system or not have preheated combustion air and therefore an easy ‘end use’ can be identified. For others the end use will need to be explored and developed. Technical assessments and an options analyses will need to be conducted.

The BREF (EC 2013b) identifies that using waste heat for steam generation, combustion air preheating and district heating. Figure 43 shows how a steel works steam system is used to collect steam from WHR units at the Coke Ovens, the BOS plant, the HSM and the annealing line for example. The steam is then utilised at various points from around the

works and is supplemented with steam from the Power Plant. Figure 43 also shows that technologies are available for capturing the waste heat and an ‘end use’ is shown for the steam generated.

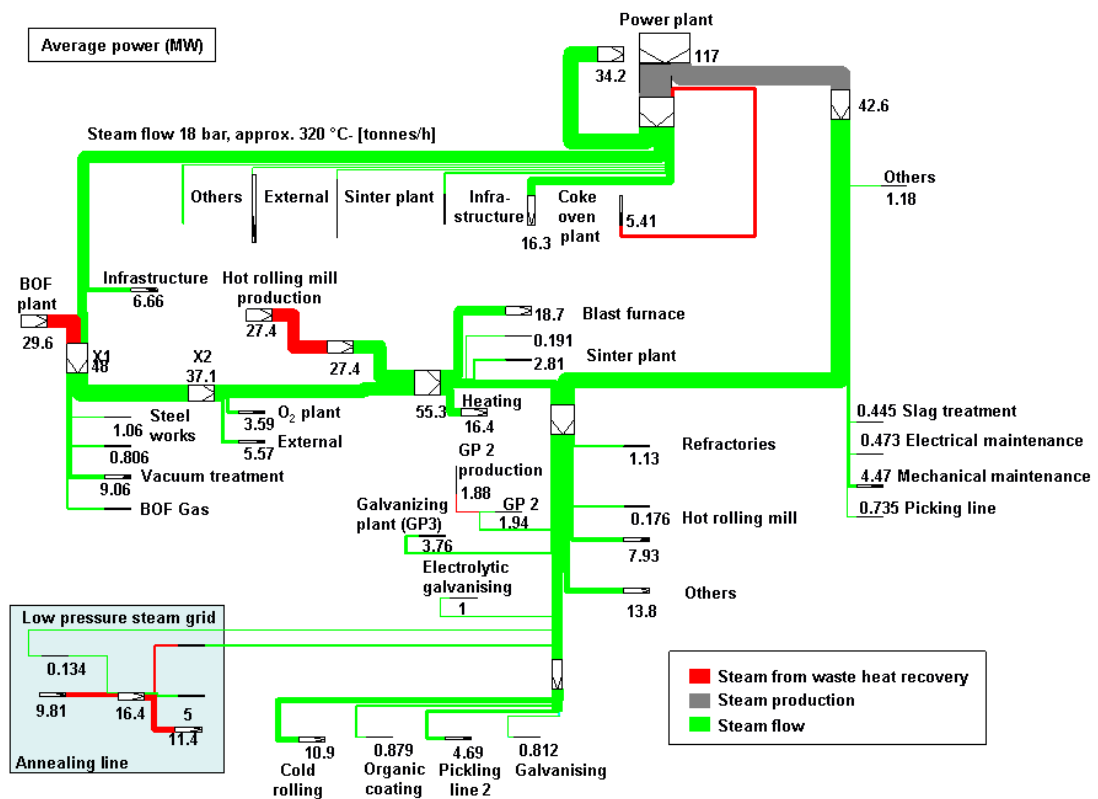

Figure 43 Example Steam System Sankey Diagram (EC 2013b)

The optimum ‘end use’ for the steel industry is very dependent on the particular steel works in question. Referring to Figure 43, it is clear to see example ‘end uses’ for any steam generated by WHR. As an example, the European Communities BREF notes for ferrous processing describes a WHR boiler on a Hot Strip Mill reheat furnace (EC 2001). Exhaust furnace gases are first used to preheat combustion air and then for steam generation. This is only suitable if the steel works has a use for the steam. Medium Grade Waste heat can then

be used to generate hot water that can then be used for process heating that will displace steam. The surplus steam can then be used to generate electricity.

Lower grade waste heat can then be used for on-site or off-site district heating networks as described by DECC (DECC 2013b) the heat network in Dunkirk, France, was built in 1985 and delivers nearly 140,000 MWh a year to customers through a 40km distribution network that covers a large portion of the Dunkirk urban community. The network is supplied primarily by recovered heat from a local steel works. The newer technologies listed in section 3.3.b will transform industries attitudes the low grade waste heat. Over time the viability of technologies such as heat pumps and ORC units will become more attractive and will alter the optimum 'end use' of low grade waste heat.

3.11 Waste Heat Recovery Opportunities at the Case Study Steel works [CSSW]

As stated in Chapter 1, it is reasonable to deduce that the UK failed to invest in WHR over many decades due to decreasing energy prices. Other countries, where energy was not historically so cheap, continued to invest in all forms of energy efficiency, including WHR. Historically, the UK steel industry has not therefore had to develop a WHR strategy or policy and its application is all but non-existent.

There were no WHR technologies employed at the case study works it was imperative that a strategy was developed and the opportunity for recovery maximised. Each waste heat source therefore needs to be investigated and options explored for its optimum 'end use'. Thus the UK steel industry has a potential advantage over its competitors. Due to the fact that WHR has not been employed, the industry has a completely clean sheet for the application of new modern technology. By mapping out the waste heat sources it is possible to develop an action plan and thus a WHR strategy can be developed.

As discussed in Chapter 2 the case study works is an integrated steel works using the BF and BOS route for steel production. As discussed in section 3.3.1, Patsos and Mullan (Patsos and Mullan 2011) mapped the CSSW as part of the before mentioned Energy Optimisation drive. The study highlighted a potential reduction of around 6GJ/Tonne of product. This section reviews the various areas of the case study works and using the referenced document suggests a) suitable technology, b) possible amount of expenditure and c) states the potential energy gain. Table 4, (McKenna 2009a), highlights the production figures for the case study works. Potential WHR for the case study site can be identified as follows.

Table 4 : Case Study Works Production Capabilities (McKenna 2009a)

Site	No. of BFs	Total BF capacity (Mt/yr)	Total sinter capacity (Mt/yr)	Total coke capacity (Mt/yr)	Total liquid steel capacity (Mt/yr)	Capacity as cast (Mt/yr)
Port Talbot	2	4.37	4.75	0.97	4.90	4.70

3.12.1 Coke Ovens

The Coke Ovens [CO] for the case study site employs wet coke quenching. This can be replaced by a nitrogen based system called Dry Coke Quenching [DCQ] (Hasanbeigi 2013) Nitrogen is blast over the hot coke to remove the thermal energy. The hot nitrogen then passes through a bank of heat exchangers to generate steam in a waste heat boiler. According to the EPA (EPA 2012) the recovery rate is 0.55 GJ/tonne coke, however the projects are very capital intensive [typically over £100M] and the payback time estimated at 36 years. For the CSSW coke production is 0.97 Million Tonnes per annum so the projected energy savings is 533,500GJ @4.9MTPA of steel make i.e. 0.11 GJ per tonne of liquid steel which equates to a net benefit of £7M per year. Figure 44 shows a typical

overview of a DCQ system. The coke is lifted up and then dropped down through a chamber with counter flowing cooling gases [typically Nitrogen]. The hot gases then pass through a boiler arrangement where the heat is exchanged to generate steam. The cooled gases then pass through the hot coke again to restart the heating cycle. Due to an installation cost of approximately £100m and a benefit of only £7m the payback is too long for consideration at the case study works. There are a few examples of operating plants around the world including the case study works sister plant in Jamshedpur.

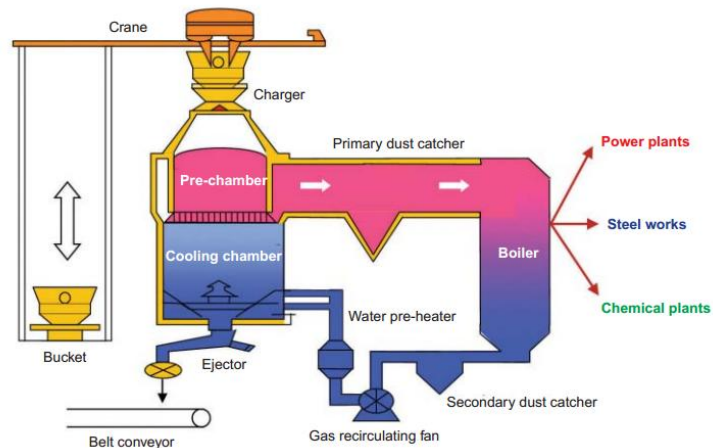

Figure 44: Example Dry Coke Quenching (Centre 2015)

The Coke Ovens process contains other areas of waste heat that could be exploited, for example the hot Coke Oven Gas is cooled prior to treatment in a bi-products plant and thus the potential for WHR technically exists but because of the corrosive nature of the gas this is not utilised. The case study works is exploring modifications to the Coke Oven by-products plant which will potentially change the steam balance. At the time of writing this thesis the available technologies were being researched by CSSW and no early indications were available. Table 5 highlights the potential benefits referenced from the BREF (EC 2013b) document.

Table 5: Potential Benefits of DCQ

Estimated Cost / £M	Steam Make / tph	Electrical benefit / MWe	Electrical benefit / £M	GJ/TCS benefit	Tonnes CO₂ benefit
100	70	12.6	7	0.11	51200

3.12.2 Sinter Plant

As described in the BREF notes (EC 2013b) heat recovered from the sinter plant can be used to preheat the combustion air for the burners and to produce high-pressure steam. The EPA (EPA 2012) also state that steam generation with sinter cooler gases using a waste heat boiler is common in Japan and was reported to recover 0.25 GJ/tonne sinter. For the CSSW sinter production is 4.75MTPA, thus the projected energy savings is 1,175,000GJ [@4.9MTPA of steel make] i.e. 0.24 GJ/T of steel manufactured. Figure 45 shows a diagrammatic view of the sintering process. As can be seen the final part of the process is sinter cooling. The sinter is cooled from around 600°C to 100°C before it is transported to the Blast Furnace stock area via conveyor belt. The process a simple air blast cooling with all the resultant hot air simply being emitted to atmosphere. Typical air flows are 400,000Nm³/h at a temperature of 380°C.

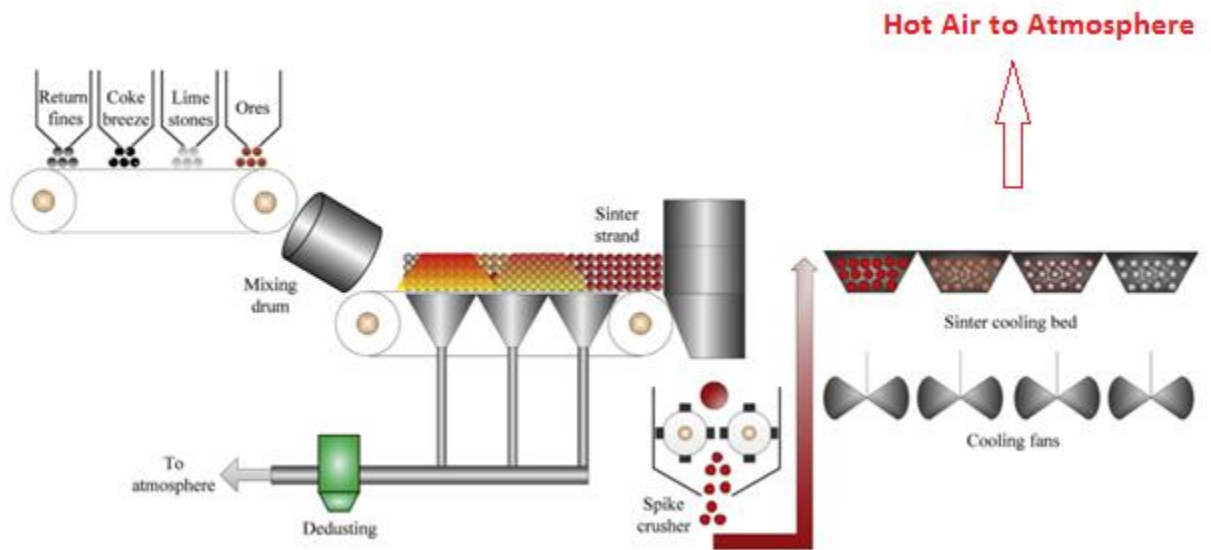
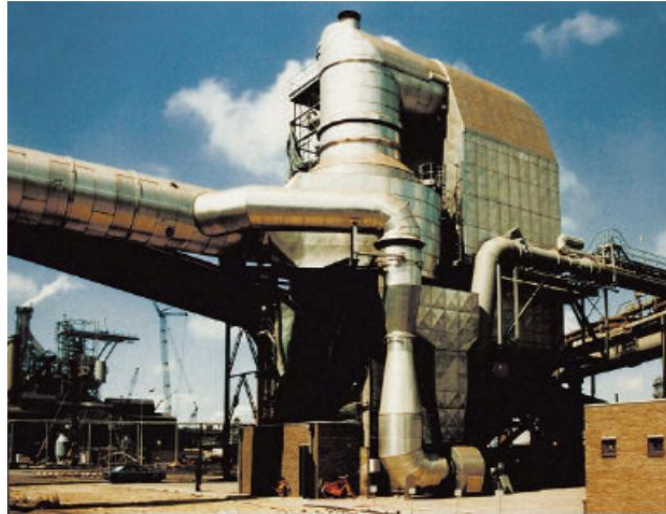

Figure 45: Sinter Bed and Cooler WHR (Liu et al. 2014)

The sinter plant of the CSSW sister plant in the Netherlands has a WHR boiler arrangement. A canopy and ductwork arrangement is fitted on top of the sinter cooler and the hot air is ducted to the boiler arrangement shown in Figure 46. The photograph shows the scale of the equipment installed downstream of the sinter cooler itself. The boiler arrangement uses Blast Furnace gas to supplement the energy from the waste heat to produce 44 barg steam for which is then exported into the works high pressure steam distribution system. The case study works only has an 11 barg distribution circuit so this is not a viable option.



Waste heat boiler downstream of sinter cooler at the
Tata steelworks in IJmuiden, Netherlands

Figure 46 IJmuiden Sinter Plant WHR unit (Oschatz 2012)

As discussed in the BREF document, and as shown in Figure 47, there are 3 main options for the sinter cooler:-

- a) No WHR
- b) WHR boiler above the sinter cooler
- c) WHR from the sinter bed exhaust gases plus the sinter cooler and the heat is used to preheat the combustion air for the burner and the sinter bed. This saves natural gas and coke consumption and enables steam generation. There are examples around the world such as SVAI in Linz. A site visit, arranged by Siemens, demonstrated the size and complexities of this type of system. A representative from the CSSW concluded that the system was physically too large for the Sinter plant at the case study works. Significant structural modifications would be required to facilitate the additional ducting required for this technique.

As option a) had no WHR unit and c) was rejected by the CSSW the author therefore explored option b) further.

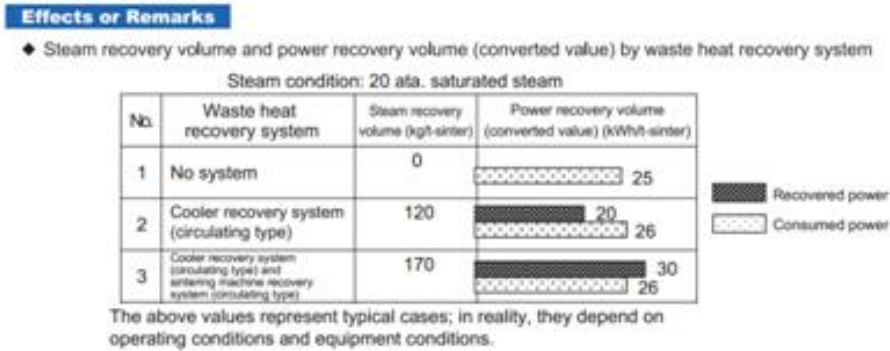

Figure 47 Example WHR potential for Sinter Plants (EC 2013)

3.12.3 Blast Furnace Stoves

As defined by the EPA (EPA 2012) The hot-blast stove flue gases can be used to preheat the combustion air of the blast furnace. Preheating can lead to an energy saving of approximately 0.35 GJ/tonne of steel. For the CSSW, iron production is 4.37 million tonnes per annum, so the projected energy savings is 1,529,500 GJ or 0.3 GJ/T of steel.

The technology uses heat pipes inserted into the hot waste gas stream that transfers the energy to the cold gas and combustion air streams. Figure 48 shows an example installation demonstrating the size of the heat exchangers required to cope with such an energy exchange.



Figure 48 Example Stoves Waste Heat Recovery Unit. (Paul Wurth 2015)

The 0.35GJ/Tonne for both Blast Furnace stoves will equate to potential gas savings of around £5m per annum. This option gives a return of investment of around 3 years providing the CSSW has a use for the gas that is saved. If the saved gas is just flared then the financial benefits will be zero. The case study works currently enriches the Blast Furnaces gas with Natural gas but in order to reduce the cost of imported Natural Gas the works is exploring replacing the Natural Gas with BOS gas. Therefore any gas savings brought about by WHR would be flared reducing the financial benefits significantly. The case study works is exploring an extension to the existing power plant (Tata 2013) in order to generate electricity from the gas that is currently flared. This would then provide the financial benefit that would be required for the project to be authorised. Table 6 summarises the option assuming the case study works has a consumer for the saved gas.

Table 6 Projected Benefits of BF Stove WHR

Estimated Cost / £M	Steam Make / tph	Electrical benefit / MWe	Gas Benefit / £M	GJ/TCS benefit	Tonnes CO₂ benefit
14	-	-	5	0.35	78,365

3.12.4 Blast Furnace and BOS Slag Heat Recovery

As defined by the EPA (EPA 2012) and discussed by Zhang et al (Zhang et al. 2013a) a modern blast furnace produces around 0.23 to 0.27 tonnes of liquid slag, at a temperature of approximately 1,450 °C, per tonne of iron. None of the current slag heat recovery systems have been applied commercially because of the technical difficulties in developing a safe, reliable, and energy efficient system. The estimated savings would be approximately 0.35 GJ/tonne of iron. For the CSSW the projected energy savings is 1,529,500 GJ [@4.9MTPA of steel make] i.e. 0.3 GJ/Tonne.

3.12.5 BOS Plant

As discussed by Kasalo (Kasalo 2010) it is possible to recover the heat energy from the BOS plant's off- gas and BOS Gas, before the gas is collected in a gas holder. The CSSW has what Kasalo describes as an 'open' cooling circuit and is in need of essential replacement because of excessive corrosion problems. The off-gas system was replaced in 1997 and in 2011 was well beyond its expected life cycle. The plant experiences considerable engineering delays due to excessive corrosion of the internal pipe work. The case study works had been exploring the replacement of the open circuit with what Kasalo (Kasalo 2010) refers to as a 'closed cooling system'. This system enables a much tighter water chemistry control and thus considerably reduces the corrosion of the pipe work

system. The case study works was not, at that time, 2011, exploring the third option which Kasalo (Kasalo 2010) refers to as the 'Evaporative Cooling System'. The case study works did not have a WHR strategy and therefore the option was not being explored.

The EPA (EPA 2012) state that the Energy savings range from 0.53 to 0.92 GJ/tonne and the payback period is estimated to be 12 years. This long payback period would not therefore be attractive to Industry.

There is another option for the BOS plant utilising newer technology. A Japanese (Engineering 2014) steel works used the Kalina cycle to generate steam from the cooling water from a 'closed cooling circuit'. This is calculated as being more efficient but the capital cost is significantly higher and the payback is much longer.(USDoE 2008).

3.12.6 Continuous Casters

Research has failed to identify a technological solution to waste heat recovery from the casters. Spirax Sarco give an example of an energy project for a Caster (Sarco 2001) in which energy is used for preheating boiler feed water. The energy flows are identified by Newcastle University but it should be noted that they have omitted to quantify the steam waste stream (Newcastle University 2011). The university summates the waste heat available as around 60-90MW per caster i.e. 0.92 GJ/Tonne. Figure 49 shows the cross sectional view of a Continuous Casting machine [Concast]. As the liquid steel flows out of the ladles, into the tundish it starts to cool and form into a slab as it flows from the mold and into the cooling zones. Between the mold and the cooling zones water is sprayed onto the forming slab to cool its surface and thus accelerate solidification. Large quantities of the water is vaporised and emitted to atmosphere as water vapour and steam. It has not been possible to find any references for recovering the heat from this water vapour. The concast

machine itself is water cooled and the thermal energy is removed and emitted to atmosphere via a traditional cooling tower. It is potentially possible to use low grade waste heat technologies to utilise this waste heat for example heat pumps. The slabs as they roll out of the cooling section are still at around 800°C. Research has identified a couple of developing options namely Photovoltaics (Zafer Utlu 2013) for direct electrical generation and steam generation from a ‘slab cooler’ (Hemmling 2012).

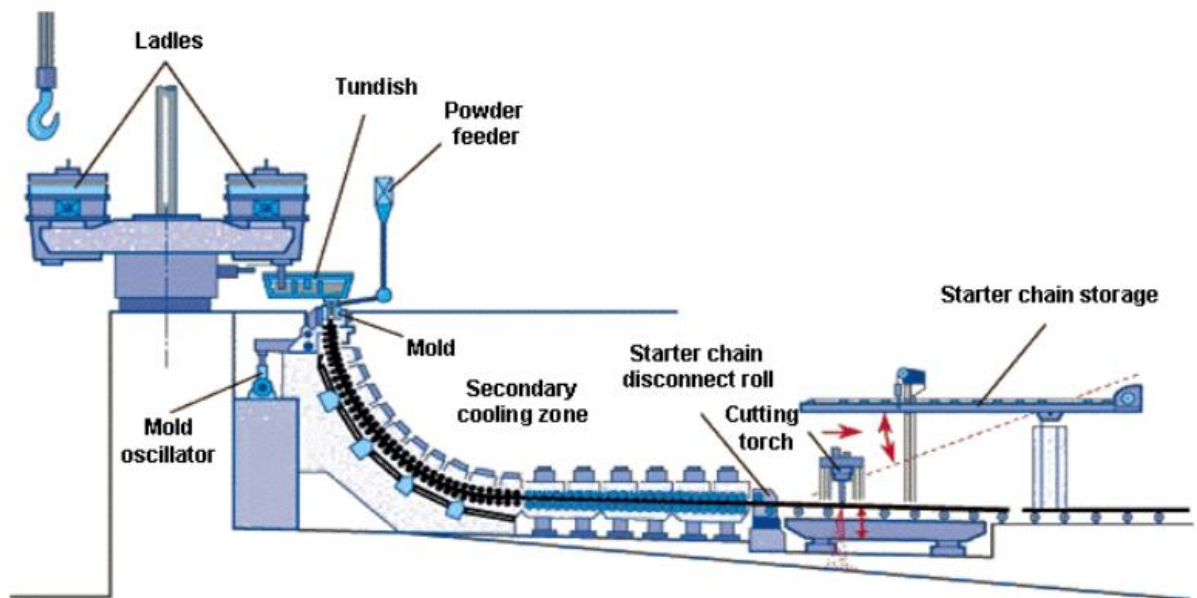

Figure 49: Caster Process Flow (EC 2013b)

Figure 50 shows the SMS development of a ‘slab cooler’. Literally a large heat exchanger is placed above the exit of the concast machine. As the slab moves along the table the water is heated and vaporised in a steam drum. Although this technology looks to have promise it is still experimental and conflicts with other initiatives. The case study works practices what is known as ‘hot connect’ where it attempts to maintain the temperature of the slab to

limit reheating costs at the start of the hot mill. Only around 30% of slabs are successfully hot connected so the potential is available for WHR when the technology is developed.

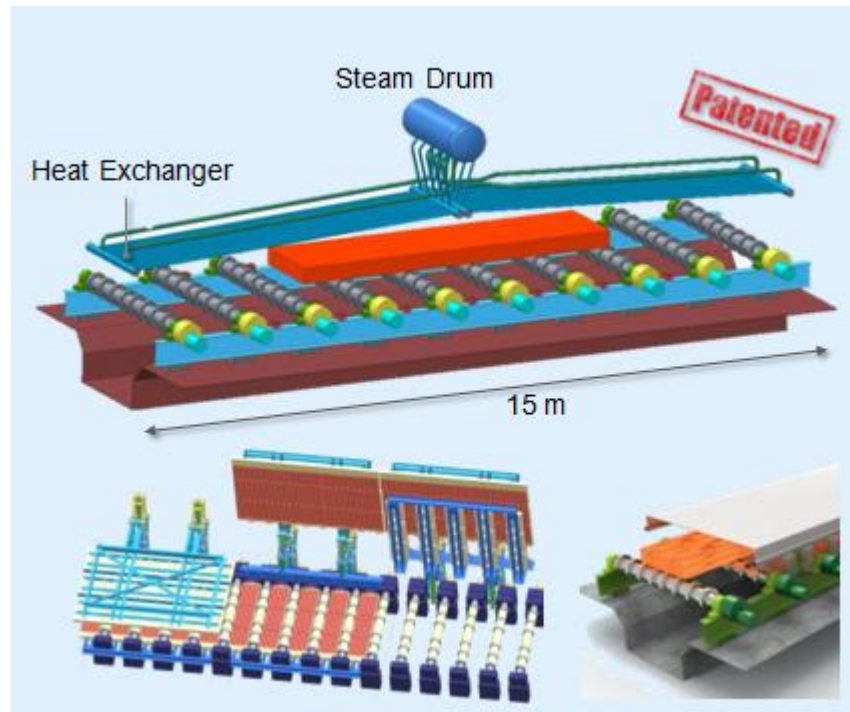

Figure 50 Conceptual Hot Slab WHR Unit SMS (Hemmling 2012)

3.12.7 Hot Mill

WHR from the reheat furnace waste gases at the CSSW is utilised for preheating the combustion air for the burners. There is further opportunity for heat recovery from the stack gases which are stated as being 25MWth [280,000Nm³/h at 250 °C] (Patsos 2011). The other sources of waste heat are primarily cooling water. An option practiced at other steel works, and is in fact employed at the case studies sister plant, is Evaporative Cooling of the furnace skids. This would entail the complete replacement of the skid system so will be capital intensive, require weeks of outage and thus only likely to be done as part of an essential replacement project. The case study works had been exploring the installation of

an additional furnace and so incorporation of an evaporative skid cooling system would be worth considering. This section therefore explores the possible steam generation from an evaporative skid cooling system should one of the furnaces need essential replacement or an additional furnace is to be installed.

The EPA (EPA 2012) state that waste heat can be recovered from the Hot Strip Mill cooling water to produce low-pressure steam. The BREF document (EC 2001) provides an example where 0.17GJ/T is recovered. For the CSSW the hot rolled coil manufacture is 3MTPA so the projected energy savings is 510,000GJ per year.

With the advances in ORC technology, Tosçelik (DURMAZ 2012) installed an ORC unit instead of an Evaporative system to reduce the water requirement of the steam system. The plant must not have an 'end use' for all the steam produced therefore it was venting steam and therefore required considerable amounts of water to top up the system. The case study works, utilising the 11bar system and the new TA would have an end use for the steam so the additional expense of an ORC unit would have minimal financial benefit.

Reining Heisskühlung overviews cooling systems including Evaporative cooling systems for Hot Strip Mills (Reining 2015).A traditional evaporative system is described in the BREF (EC 2013) document as shown in Figure 51.

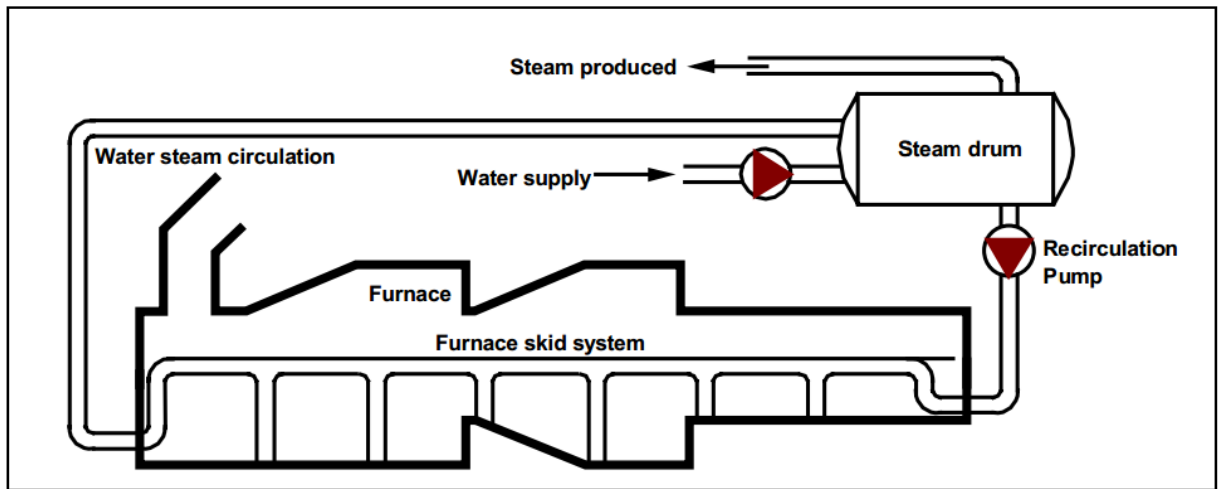

Figure 51 HSM WHR Example

The stated BREF (EC 2013) example lists EKO Stahl that produces 10-41 tph of steam at 23 bar. The case study plants sister works also has an Evaporative cooling system on its Hot strip mill producing steam for export to the steam distribution circuit.

As discussed the conversion from a water cooling system to an Evaporative cooling system is simply too disruptive for consideration. However, when the works decides it needs to overhaul a furnace or needs to add an additional furnace then this modelling work proves that the 11bar system can act as an end use for the energy recovered.

Table 7: Potential Benefits of HSM WHR

Estimated Cost / £M	Steam Make / tph	Electrical benefit / MWe	Electrical benefit / £M	GJ/Tonne benefit	Tonnes CO ₂ benefit
8	15	2.7	£1.4	0.17	94,000

3.12.8 Continuous Annealing Process Line [CAPL]

The EPA (EPA 2012) stated that heat recovery can be accomplished by generating steam from recovered waste heat or by installing recuperative or regenerative burners in the annealing furnace. Information was obtained from CMI (CMI 2012) for the case study works which equated 0.02 GJ/Tonne of potential steam generation from the exhaust stack.

The Continuous Annealing Process Line [CAPL] incorporates a radiant tube heating furnace to heat the steel strip temperature up from ambient to its annealing temperature of approximately 800 °C. This radiant tube furnace is Natural Gas fired and exhausts to atmosphere. The average flow rate of the hot waste gas is 50,000Nm³/h at 700 °C gives an available energy content of around 11MW thermal. The gas is diluted with ambient air to reduce the temperature down to 350 °C to protect the induction fan.

Data analysis of the exhaust temperature indicated that the temperature variability negated the possibility of generating 11bar steam. There would be considerable periods of time where the temperature was too low for 11barg superheated steam to be generated. It was identified that the local consumers of 11bar steam were actually being supplied by 3.5 bar steam through pressure reduction stations. These local consumers are processes within the CAPL line itself and the Cold Mill area of the plant as shown in Figure 52. The individual consumers are not metered and so this breakdown was calculated from heat and mass balances and also manual temperature readings. The two main supplies to CAPL and the Cold Mill area are metered so the sum of the consumption is known and is shown to be as high as 16tph in the winter but this drops to 8tph in the summer period when the bay and office heating units are turned off.

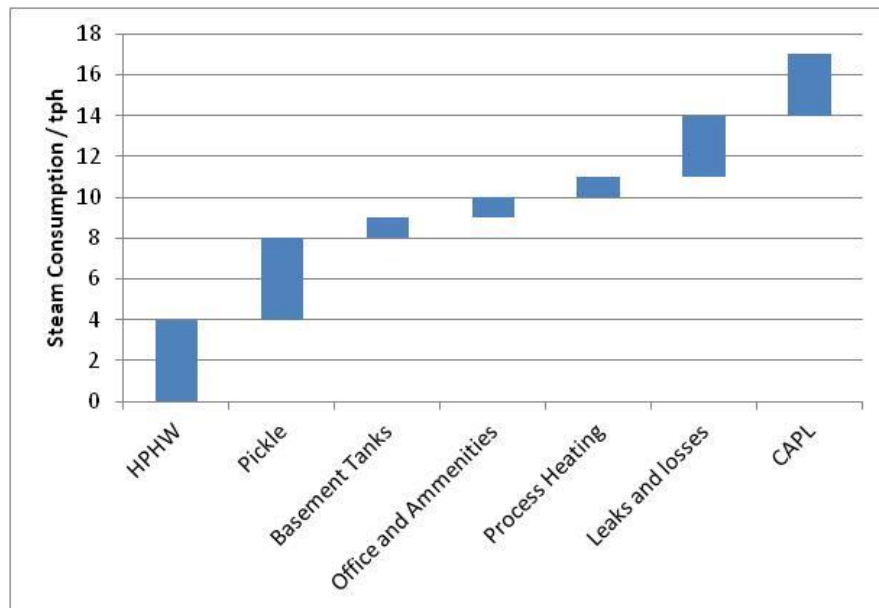

Figure 52 Mass Balance of the Cold Mill and CAPL steam consumers

The consumers are all fed with 3.5 bar steam. It can therefore be derived that a WHR boiler could supply this 3.5bar steam instead of the steam being supplied directly off the 11bar circuit. This concept would therefore enable more 11bar steam to be used for electrical generation via the new TA thus providing a payback for the WHR boiler project. The installation of a WHR boiler would necessitate the removal of the dilution air system and would enable a heat exchange of around 4.8MW thermal generating a predicted average of 5 tph of steam (CMI 2012). Utilising data for plant flow rates and temperatures it is possible to predict the possible spread of steam make as shown in Figure 53. As can be seen the spread is very wide and so any ‘end use’ for the steam must have the necessary capability to cope.

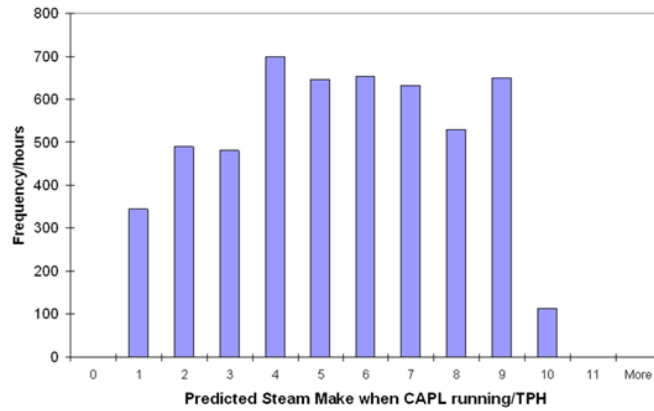

Figure 53 Predicted steam make from the CAPL WHR Boiler

Figure 54 shows the overall plant configuration indicating that the CAPL and Cold Mill areas both have local 3.5bar steam circuits both supplied by steam from the 11 bar distribution circuit. The figure also shows how the WHR boiler would plug into the CAPL and Cold Mill circuits thus reducing the dependence on the 11 bar circuit.

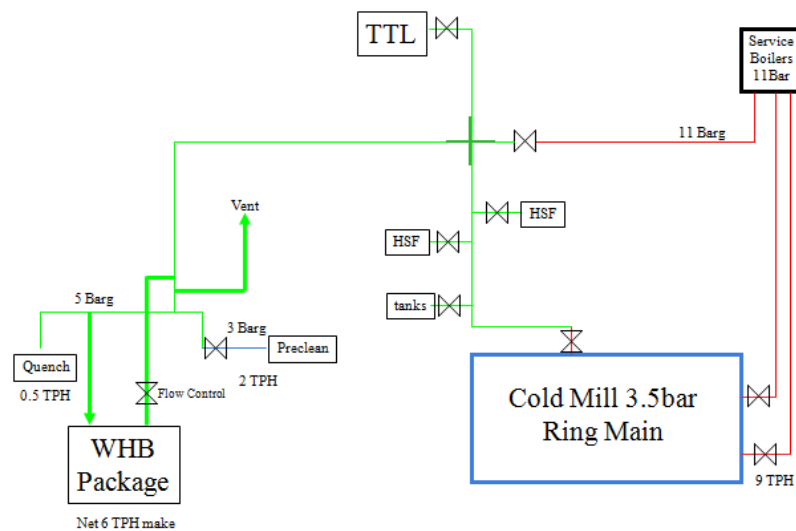

Figure 54 Steam System layout for the CAPL and Cold Mill areas

3.12.9 Synopsis

The above overview of WHR opportunities in the case study works is summarised in Table 8. The table shows blanks where technology is not yet readily available or used throughout Europe. This significantly reduces the achievable WHR projects for the case study works. The annual energy is stated as being 7.3PJ which equates to 1.49 GJ/T of high grade waste heat. This is considerably less than that suggested in Table 1, Table 2 and Table 3, but as highlighted there is no technology available to exploit all the sources of waste heat. The table does not include low grade waste heat opportunities.

Table 8: Case Study Works WHR potential

		Heat Source	Temp Degrees °C	GJ/T	MTPA	PJ PA
Coke Ovens	Sensible Heat in the Coke Ovens	Gas	980	-	-	-
Coke Ovens	Exhaust gas from combustion of CO gas	Gas	200	-	-	-
Coke Ovens	Heat Recovery from solid radiant coke	Solid	800	-	-	-
Blast Furnaces	Exhaust gas from blast stoves	Gas	250	0.300	4.4	1.311
Blast Furnaces	heat recovery from slag	Solid	1300	-	-	-
BOS	Heat recovery from BOS gas	Gas	1700	0.920	4.9	4.508
BOS	Heat recovery from BOS slag	Solid	1500	-	-	-
EAF	Electric Arc Furnace	Gas	1200	-	-	-
Castors	Heat Recovery from hot slab	Solid	1600	-	-	-
Hot Rolling	Heat recovery from coil	Solid	400	0.1	3.0	0.300
CAPL	Heat recovery from exhaust gas	Gas	700	0.02	3.0	0.060
Sinter Plant	Heat Recovery from cooler	Gas	400	0.240	4.8	1.140
					Total PJ	7.319
					Total GJ/T	1.49

The potential for steam generation for using WHR boilers for the various works areas have been considered. The blast furnace stoves were not included in this study as the best use of the waste heat is preheating the combustion air for the stove burners.

Analysing the possible use of steam generators, the predicted steam generation is shown as a bar chart highlighted in Figure 55. Referenced information for the following works areas provides information on predicted steam production from the high grade waste heat sources. All areas would utilise waste heat recovery boilers. For the sinter Plant, Siemens (Siemens 2014) identified typical values of 40TPH steam generation from a waste heat recovery boiler fitted above the sinter cooler system. For the BOS plant, Kasalo (Kasalo 2010) describes the replacement of the BOS gas cooling system with a waste heat recovery boiler system. It was stated that a typical steam production for the CSSW was about 40TPH. Similarly, for the hot strip mill [HSM] and the CAPL (CMI 2012) predicted steam generation of 15TPH for the HSM and 7TPH for the CAPL was identified. The cumulative impact is highlighted in Figure 55 and shows that around 102TPH could be generated from the high grade waste heat sources.

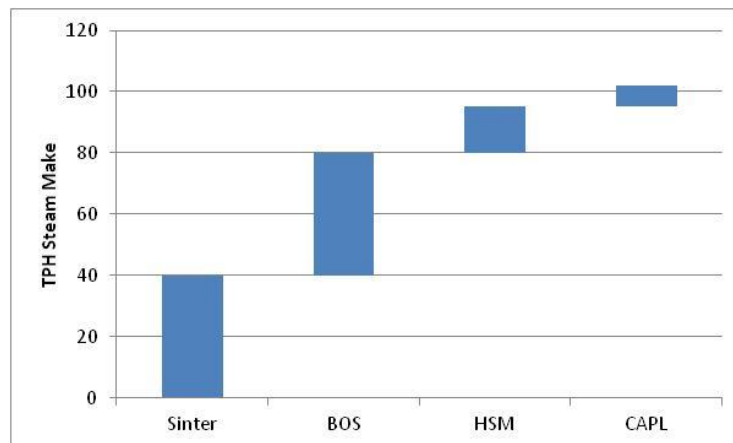

Figure 55: Predicted Steam Make from the Case Study High Grade Waste Heat Sources

If this 102 TPH of steam was used for electrical generation, 0.18MWe per TPH of steam flow would generate 18.36MWe. An electricity supply price of £66/MWe would equate to an annual financial benefit of around £10 million. This is obviously of significant potential benefit to the case study works but of course the technology employed and 'end use' needs to be analysed before a full business case can be developed.

Table 8 identified the low grade waste heat sources. As explained these heat sources can be used to create hot water that could then be used as a heating medium, replacing valuable steam. Low grade waste heat can also be used externally for a district heating system (Newcastle University 2011). This is discussed later in thesis, for now the focus is on finding the optimum 'end use' for the high grade waste heat sources.

In a steel works with an existing steam distribution circuit where the steam is used for building and bay heating the 'high grade' waste heat boilers can then be classed as 'steam generators' and 'lower grade' waste heat sources can be classed as 'steam savers'. This way lower grade waste heat projects can be employed to save steam and higher grade waste heat projects used to generate more valuable steam. It is therefore imperative that the steam system for the case study works is understood in detail. As potential high grade steam projects come on line the system would act as a carrier to bring additional supplies to electricity generation sites. Thus the system behaviour is crucial to ensure optimum conditions can be achieved. It is also important to understand the consumers of steam within the case study works to properly assess if the steam supplied to these consumers can be displaced with hot water from lower grade waste heat sources. Thus maximising steam

production for electricity generation, limiting load imports and thus adding to the goal of the CSSW being self-sufficient and reducing the impact of future security of supply issues.

3.13 Summary

The Chapter looks at WHR for the steel industry and in particular it examines the opportunity in each area of the CSSW thus fulfilling aim 2. The Chapter identifies over £10 million per year in increased electrical generation from steam generated by high grade WHR boilers. The typical barriers that prevent industry investing in WHR are also highlighted defining that the many technical options presented when industry explores the optimum 'Technology' and 'end-use' for any such project.

The CSSW has the advantage of the fact that, because WHR has not been employed, the works has in effect a 'clean sheet' for the application of new technologies. By mapping out the waste heat sources it is possible to develop a plan and a strategy. However, to define the optimum 'end use' it is clear that the steam distribution system for the CSSW needs to be understood in detail. The next chapter describes the steam distribution circuit for the case study works and explores the use of the system for a potential WHR project.

4 Steam distribution

4.1 Introduction

This Chapter overviews steam distribution systems, describes and analyses the distribution system at the CSSW. The potential steam generation from the installation of Waste Heat Recovery [WHR] boiler at the Basic Oxygen Steelmaking [BOS] plant is explored and modelled. An analysis of the case study plant highlights an extremely complex steam distribution and that a fluid flow model is required for circuit to ensure that it is in fact capable of accepting steam from the potential WHR boilers. The chapter also highlights how this study is used to develop a potential WHR strategy for the case study works.

4.2 Steam and Steam Distribution

In 1947 Lyle (Lyle 1947) published “The Efficient use of Steam”, this then became known as the ‘bible’ for Engineers. He started his introduction by stating that “steam is industry’s most wonderful, flexible, adaptable tool”. Then in 2009 the European Commission’s Best Available Technique Reference document [BREF] on Energy Efficiency (EC 2013b) states that steam, due to its low toxicity, is an energy source that is a safe, transportable, highly efficient, with high heat capacity and relatively low cost. Steam holds a significant amount of energy per unit mass that can be extracted as mechanical work through a turbine or as heat energy for process use. Since most of the heat content of steam is stored as latent heat, large quantities can be transferred efficiently at a constant temperature which is a useful attribute in many process heating applications. Modern techniques for utilising and optimising steam have been developed and has many applications in both industry and service sector such as hospitals. More heat energy is contained within high temperature steam so its potential to do work is greater. The increasing use of combined heat and power

[CHP] systems demonstrates the high regard for steam in today's environmental and energy-conscious industries.

As defined by the BREF for the Iron and Steel sectors (EC 2013b), steam is an ideal energy transporter for this industry. The industry generates significant quantities of indigenous waste gases that can be efficiently combusted in traditional boilers to generate high pressure steam. Furthermore, the sector also requires vast amounts of electricity to drive its processes. Using these gases to generate steam and electricity was therefore an obvious evolutionary step. Many processes also require local mechanical work, vacuum generation, as well as a heat source, thus using this source provided an opportunity for sites to service some of the important process needs.

As highlighted by Spirax Sarco 'The steam and condensate loop', steam has come a long way since the Industrial Revolution. Steam is an essential part of modern life and around 70% of electricity is generated using steam and is also essential for food processing, textile, chemical, medical, power, heating and transport industries. Steam provides a means of transporting controllable amounts of energy from a central automated boiler house. It can be efficiently and economically generated and efficiently transported to the end point of use.

Figure 56 shows a typical steel works steam system (EC 2013b), the BREF notes (EC 2013) also explains that a steam distribution system is very common in steel works around the world. The figure shows how the steam system flows all around the works and connects steam generators and steam consumers together. Steam from WHR units at the BOS plant, the hot rolling mill, the Coke Ovens and the Annealing line are shown as well as an export from the Power Plant. It also highlights the complex nature of use versus generation. In

reality the distribution system is generally more complex than that shown in Figure 56 due to the historical development of the steel plants in the world.

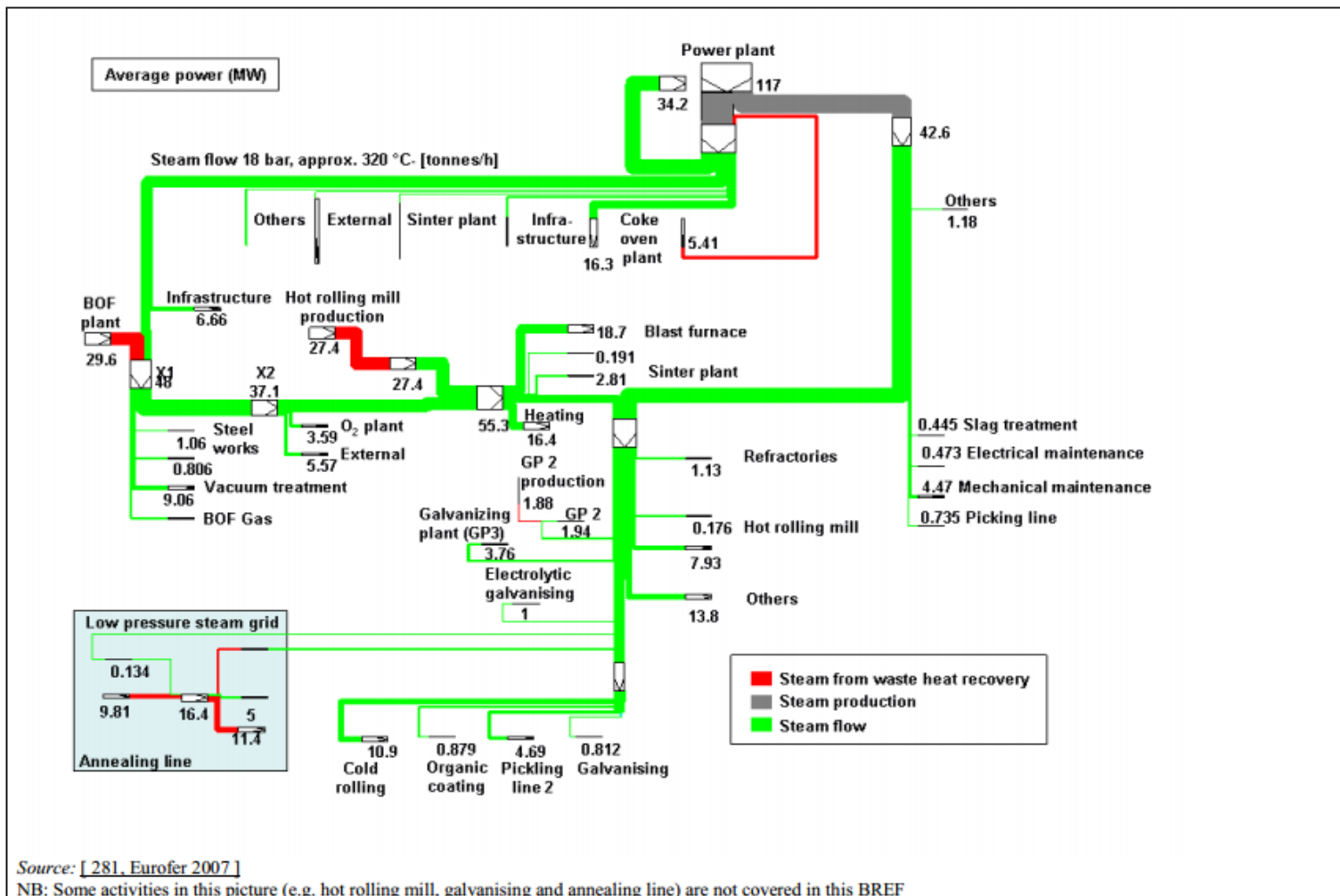

Figure 56: Example Steam Distribution System (EC 2013b)

4.3 Steam distribution circuit at the CSSW

The steam distribution system at the CSSW is exported from the Power Plant and the Service boilers at 11 barg and is superheated to 280-320°C. The steam throughout the distribution circuit is classed as ‘superheated steam’. Temperature transducers at the extremity of the circuit show that the steam is still within the superheated region. Superheated steam is defined in Figure 57 which shows a typical Temperature/Enthalpy relationship for steam. As shown by the figure superheated steam on the furthest right hand side of the diagram and is dry and can therefore be treated as a gas (Sarco 2015).

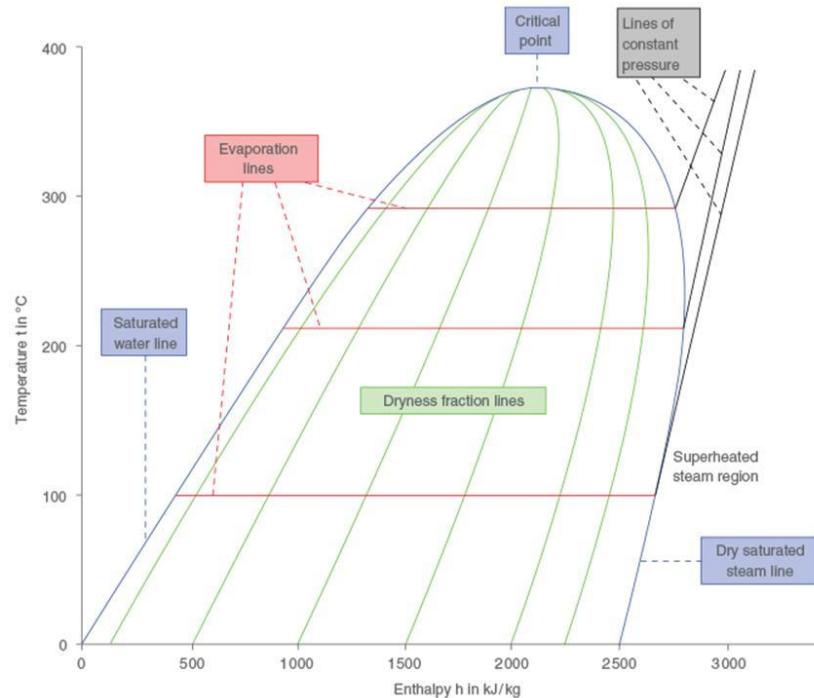

Figure 57: Steam Temperature Enthalpy Diagram (Sarco 2015)

The distribution circuit reaches all parts of the steel works apart from the Sinter Plant. Thus the CSSW has a typical layout as described in the BREF, as shown in Figure 4.1, i.e. steam is generated by burning indigenous gases in traditional boilers. As a typical combined heat and power plant this steam is primarily used for electrical generation and also to drive large

air blowers for the Blast Furnace operation. As a point of interest, the CSSW was defined by Melo (De Melo 1992) as the UK's largest CHP system back in 1992. In fact reviewing the publication little has changed for the steam system at the case study works since the publication. As shown in Figure 58, some of this source is exported from the power plant at 11 barg super-heated steam at about 300°C and distributed to other works areas for use as motive power or thermal energy. Due to the sheer scale of the steelworks [approx. 4km by 1.5km] this site also requires additional boilers known as the "Service Boilers". The main objective for these boilers is to ensure the pressure and temperature of the steam is maintained at the extremities of the distribution system. These boilers again use indigenous generated fuels. The works is therefore using indigenous fuels for generating 11 barg steam for the works areas. As shown in Figure 56, a steelworks steam circuit being supplied by waste heat boilers as well as by an export from the Power Plant. This infers that waste heat can be utilised to generate the works steam rather than the indigenous gases. Using waste heat to generate the steam required by the site would thus release the indigenous fuels for other purposes i.e. further electrical generation or displacement of imported natural gas.

For the case study works, the 11 barg steam system was seen by the CSSW as an 'old fashioned' element of the works and had limited investment over many years in terms of both maintenance and /or process improvement. What made matters worse was the fact that electricity was generated from the pressure reduction down to 11 barg. So the more steam that was pressure reduced, the more electricity was generated. Thus the more leaks and inefficiencies there were in the steam system the more steam was pressure reduced and more electricity was generated. Hence, unfortunately, the less efficient this system was, the more electricity was generated. There were no financial drivers for an efficient steam system. The lack of investment was evident by the number of leaks and areas of missing

insulation. Questions were being asked about the future of the steam system and decentralisation seemed the way forward. The steam system was surveyed and studied and calculated losses of at least 6 tonnes per hour were recorded (Sarco 2012). It was recognised that this was wasting energy but again there was not the financial incentive for rectification or improvement. The steam mains cover virtually the whole area of the case study site and totalled over 20km in length. Even though the pipe work looked tired it was sound and was regularly inspected in accordance with the relevant pressure regulations. Large diameter steam distribution circuits are expensive to install and can cost well over a £1,000 per metre. The steam mains were, therefore a valuable asset to the works, but was underutilised, needed some investment but even more importantly was already in place ready to be used if required.

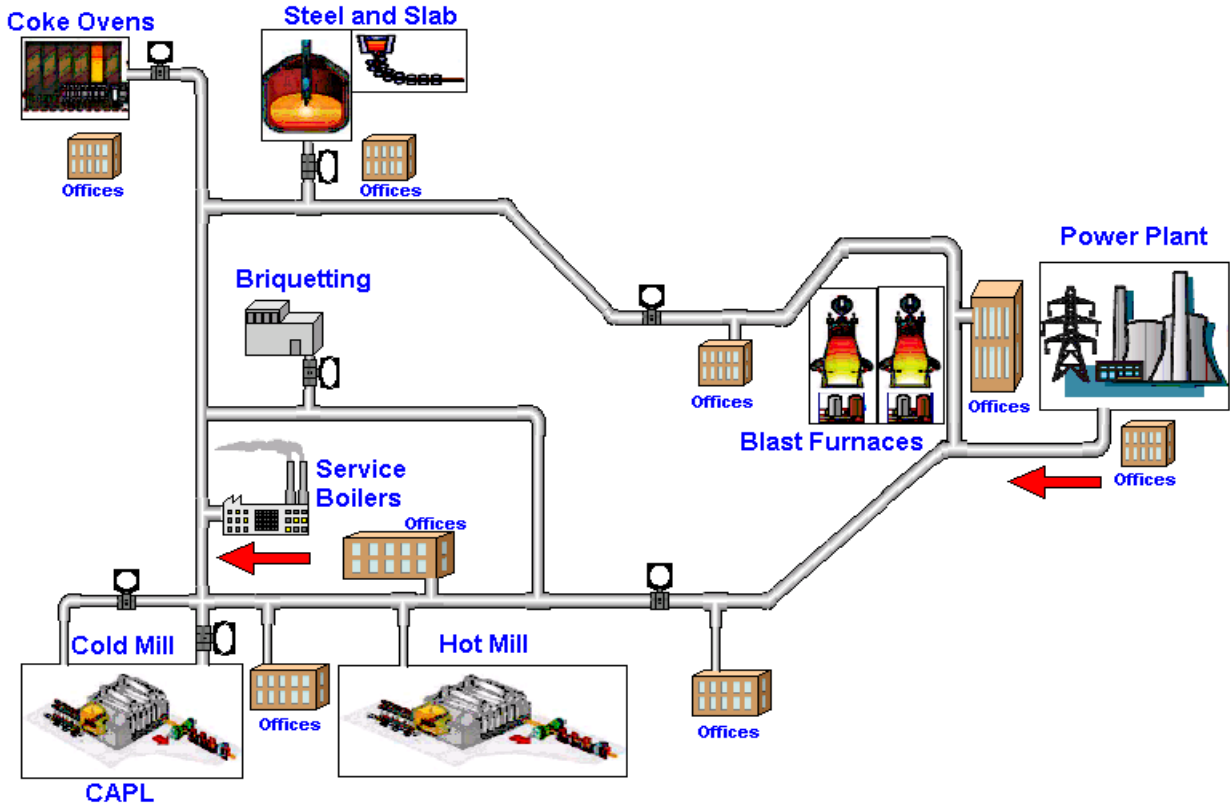

Figure 58 Case Study Steel Works 11barg Steam Distribution System

There are many tools and techniques for improving the efficiency of steam distribution systems. The US Department of Energy (USDoE 2014) have developed a whole suite of tools for engineers to calculate and study efficiency improvements in their steam system. These tools namely the Steam System Modeller Tool, Steam System Scoping Tool and the Steam System Assessment Tool enable engineers to study a system and develop an energy improvement plan. In Europe the BREF notes for Energy Efficiency (EC 2009) includes steam system efficiency techniques. Another well respected tool in the best practice guide by Swagelok (Swagelok 2014) and most readily available is the Spirax Sarco publication on 'Steam and the Condensate loop'. All of these publications make recommendations to ensure efficient steam generation, steam distribution and steam consumption by recommending steps to improve boiler efficiency, insulation techniques, steam condensate management and flash steam recycling.

To understand the condition of the distribution circuit a thermal imaging survey of the whole circuit was undertaken. The study concluded that the insulation was in a relatively good working order. With steam temperatures of up to 320°C and an outer cladding temperature of less than 40°C, it was concluded that the insulation although scruffy, was doing its job. Figure 59 shows the locations used for the study. The bulleted numbers highlights the location of the thermal images that were taken. An example section of the steam mains is shown with some of the thermal images shown in Figure 60 and Figure 61. The 'hot spots' [i.e. the sections of missing insulation] can be clearly identified as the bright colour areas on the two figures.

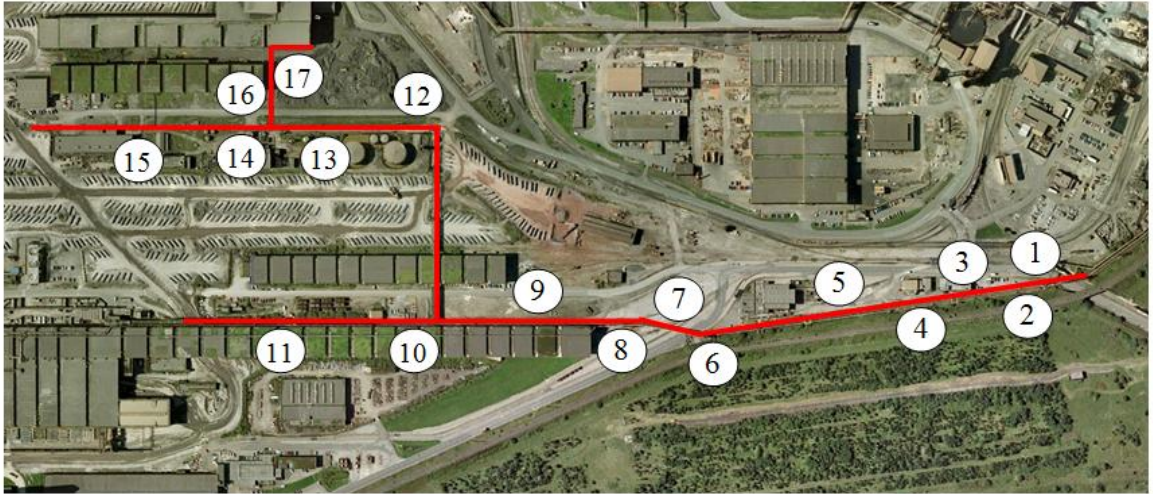

Figure 59 : Section B Steam System Inspection Points



Figure 60: Thermal Image taken at point 12

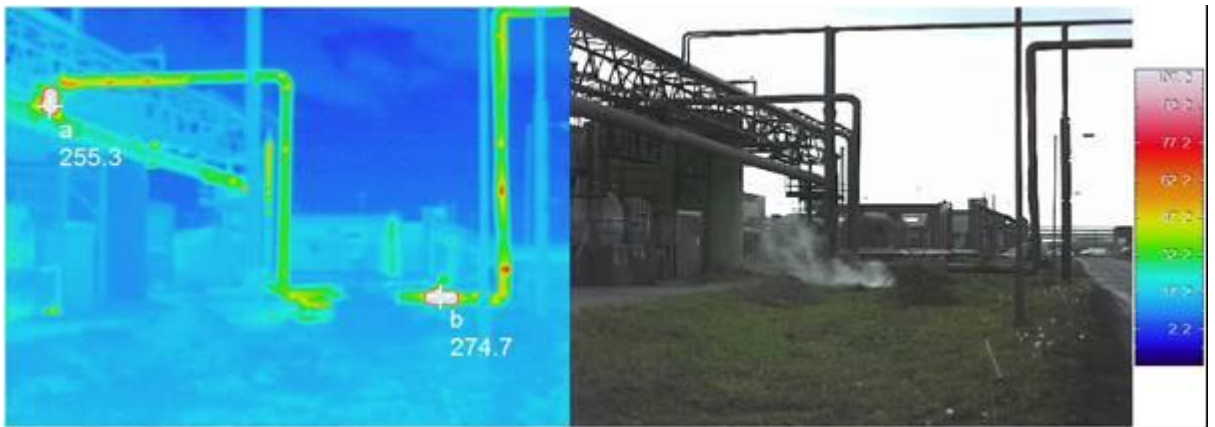

Figure 61: Thermal image from Point 16

Spirax Sarco were also invited to undertake an independent survey (Sarco 2012) the steam mains. Using ultrasonics and visual techniques the survey of the whole distribution circuit calculated that the system was losing 2 tph through leaks, 2 tph through failed steam traps and 1.5 tph from missing insulation. Figure 62 shows examples of the typical leaks identified in the surveys. Although the steam distribution mains were in reasonable condition there were several efficiency gains to be made in order to bring it up to what would be described as a good standard, for example a few failed steam traps and missing insulation.



Figure 62 Examples of steam leaks from the distribution circuit

4.4 Mass Balance analyses for the case study works

A schematic of the metered and unmetered consumers are shown in Figure 63 which demonstrates the limited number of consumers that are metered. Many of the consumers are variable or even batch so it's difficult to understand the total demand at any one time.

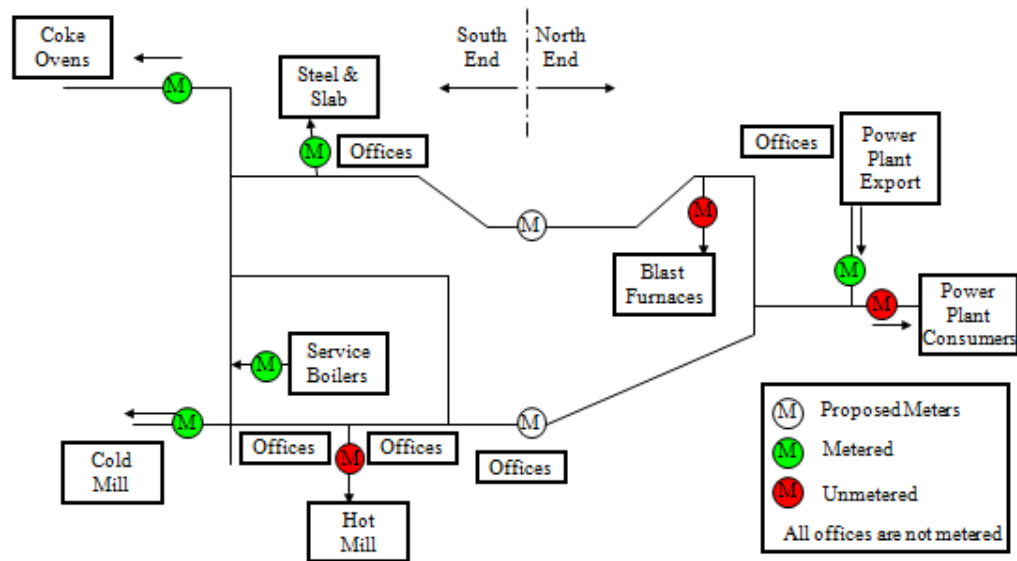

Figure 63 CSSW Steam Metering Schematic

Historical data was obtained for the case study works and Figure 64 and Figure 65 were produced to show the total consumption. These figures show a maximum demand for the ‘plant based’ consumers of around 160tph and the demand in the power plant is about 65tph. This suggests a maximum consumption was about 220tph. This was based on information built up historically on the consumers estimated consumption. Superheated steam is expensive to meter so the works has only invested in meters where it can be justified. In order to assist with this study the works installed two new meters that would help determine the North and South consumptions. Figure 63 shows were the meters were installed [marked as ‘proposed meters’]. These meters confirmed the mass balance for the South end of the works and thus helped configure Figure 64 and Figure 65. The bars in ‘green’ are metered, all others are not metered.

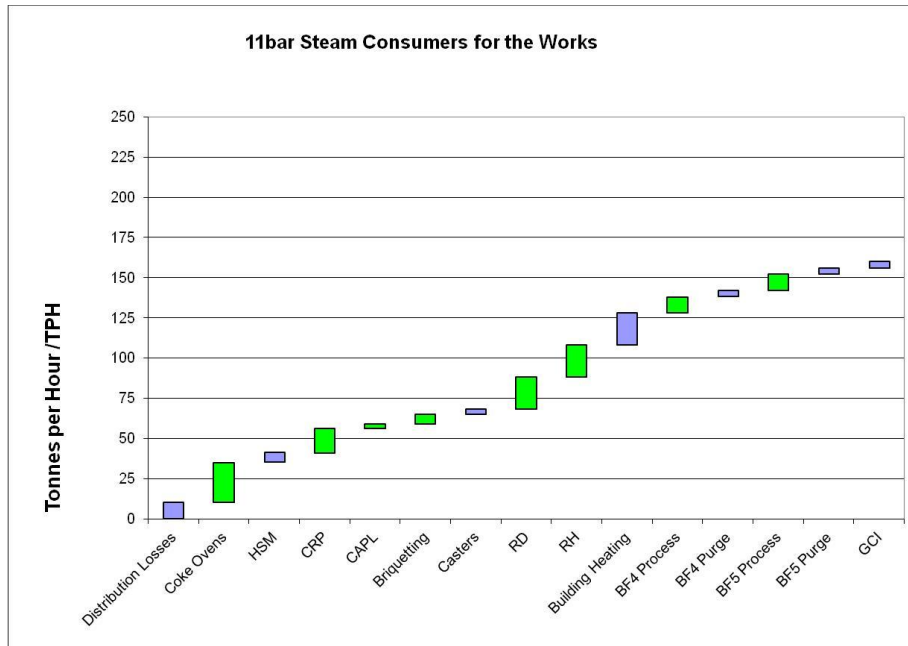

Figure 64 Distributed Steam Consumption for the case study works

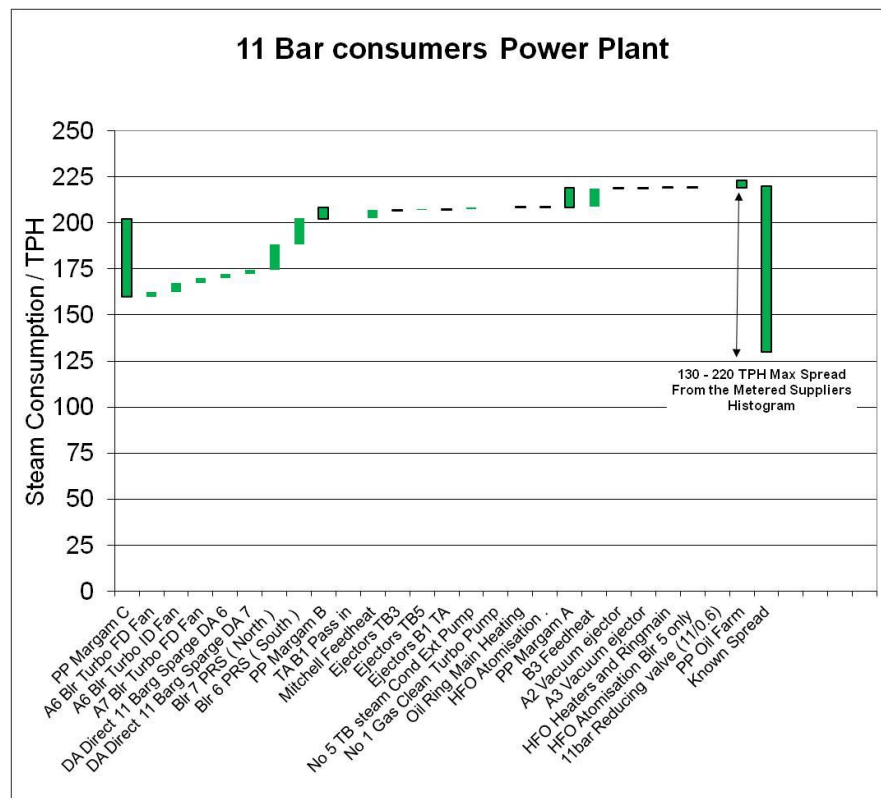

Figure 65 Power Plant 11bar steam consumption

In order to confirm this total consumption figure it was decided to plot 11bar generation and consumption at a higher level as shown schematically in Figure 66 . These higher level meters are known to be calibrated and more accurate, the figure shows 11bar steam from the ‘Service Boilers’, the ‘44/11 TA’ and the ‘High Lift Pump’ [HLP] as the inputs and the metered ‘major Power plant consumer’ and all other ‘consumers’ as outputs.

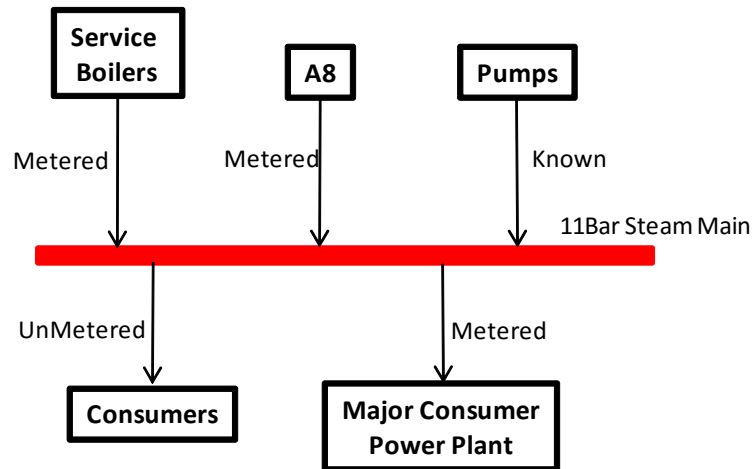

Figure 66: High level consumption calculation for 11bar steam

Using this technique, Figure 4.11 was produced which shows a plot of 6 months of plant data. It was evident that the total consumption of 11bar steam ranges from 130 to 220tph and the most frequent value being around the 170tph level. It should be noted that the maximum correlates with that totalled by the analysis of the historical data as shown in Figure 64 and Figure 65. Thus the ‘bottom up’ analyses of consumers and the ‘top down’ analyses by ‘meter’ concurs and is in agreement providing some confidence in the analyses. The variability and the batch process of some of the consumers explains the range and due to the summer / winter effect when office and bay heating is turned on/off.

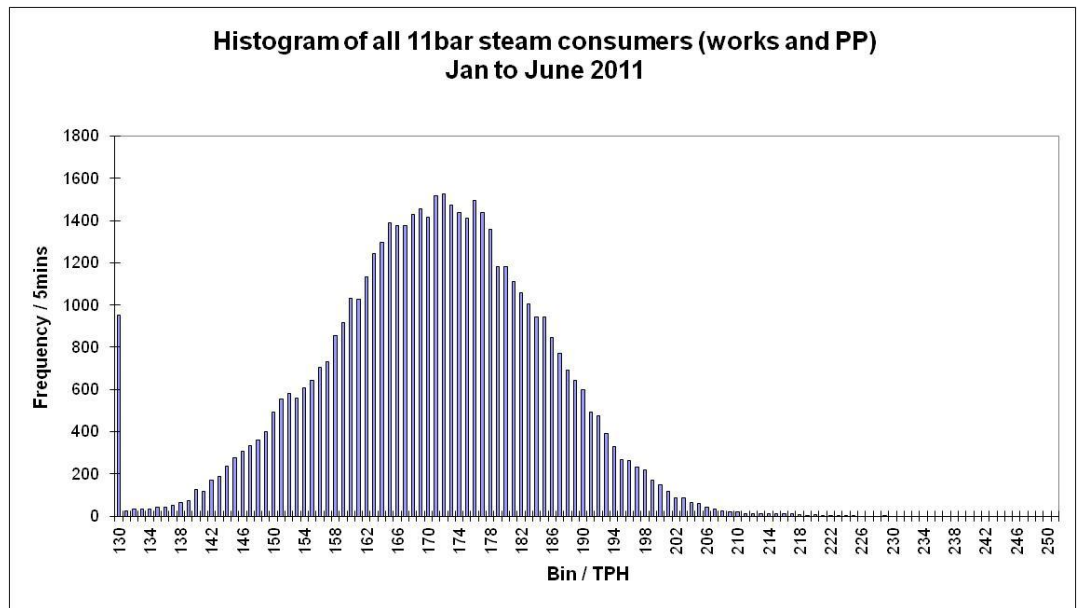

Figure 67 Histogram of high level 11bar metered consumption

It is therefore clear from this analyses that the case study works consumes on average 170 tph of steam and therefore, has the capacity to act as an effective ‘end use’ for any steam generated by waste heat recovery boilers. To further understand what the steam is used for at the case study works, Figure 68 shows a pie chart of the end consumers. This is a pie chart of the distributed steam only and not of the steam used within the power plant. As shown by the figure over 30% of the steam is used for process heating. Further analyses of this heating demand shows that these processes only require 90 °C maximum. The works is therefore using 11 barg superheated steam at 300 °C for process heating up to 90 °C. This is not good practice as defined by Spirax Sarco . These processes would be better off being heating by hot water or a lower pressure/temperate steam supply.

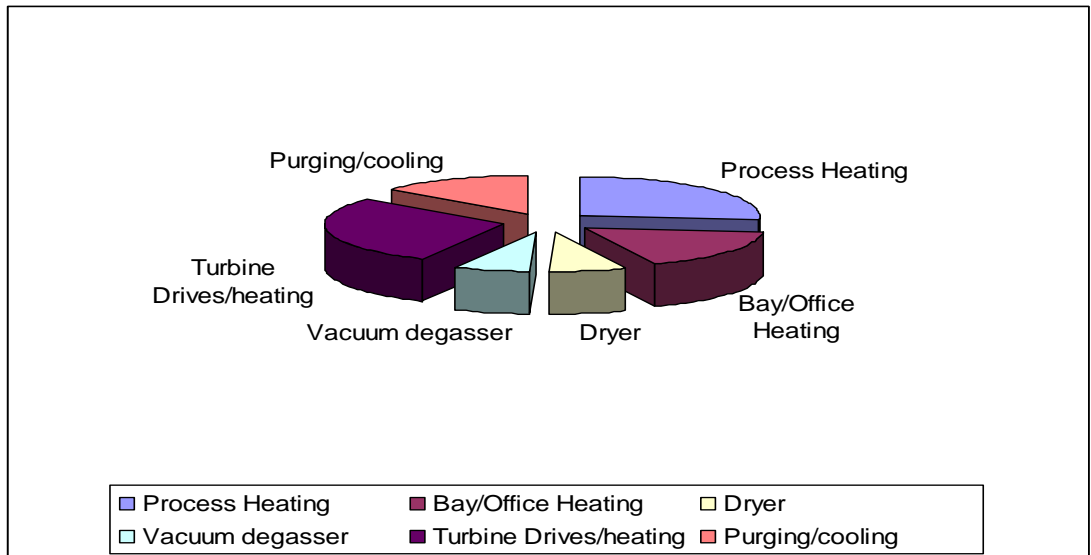

Figure 68 Pie Chart of 11bar steam consumers by type of use

To understand the whole steam system for the case study works Figure 69 was produced which shows a Sankey diagram of the whole steam system needs more words. It can be seen that the boilers are generating 127bar steam and 44bar steam. This steam is used internally and exported to the 11bar network. The figure also shows the service boilers ‘topping up’ the 11bar steam to match demand and ensure sufficient pressure and temperature for the coke ovens as shown in Figure 69. The figure shows how complex the steam system is. The power plant at the case study works generates around 70MWe which is around 50% of its demand. The ability to increase on site generation not only introduces the possibility of monetary savings from reduced electrical imports but also the reduced risks of the possible industrial blackouts as previously described.

Port Talbot Steam Sankey

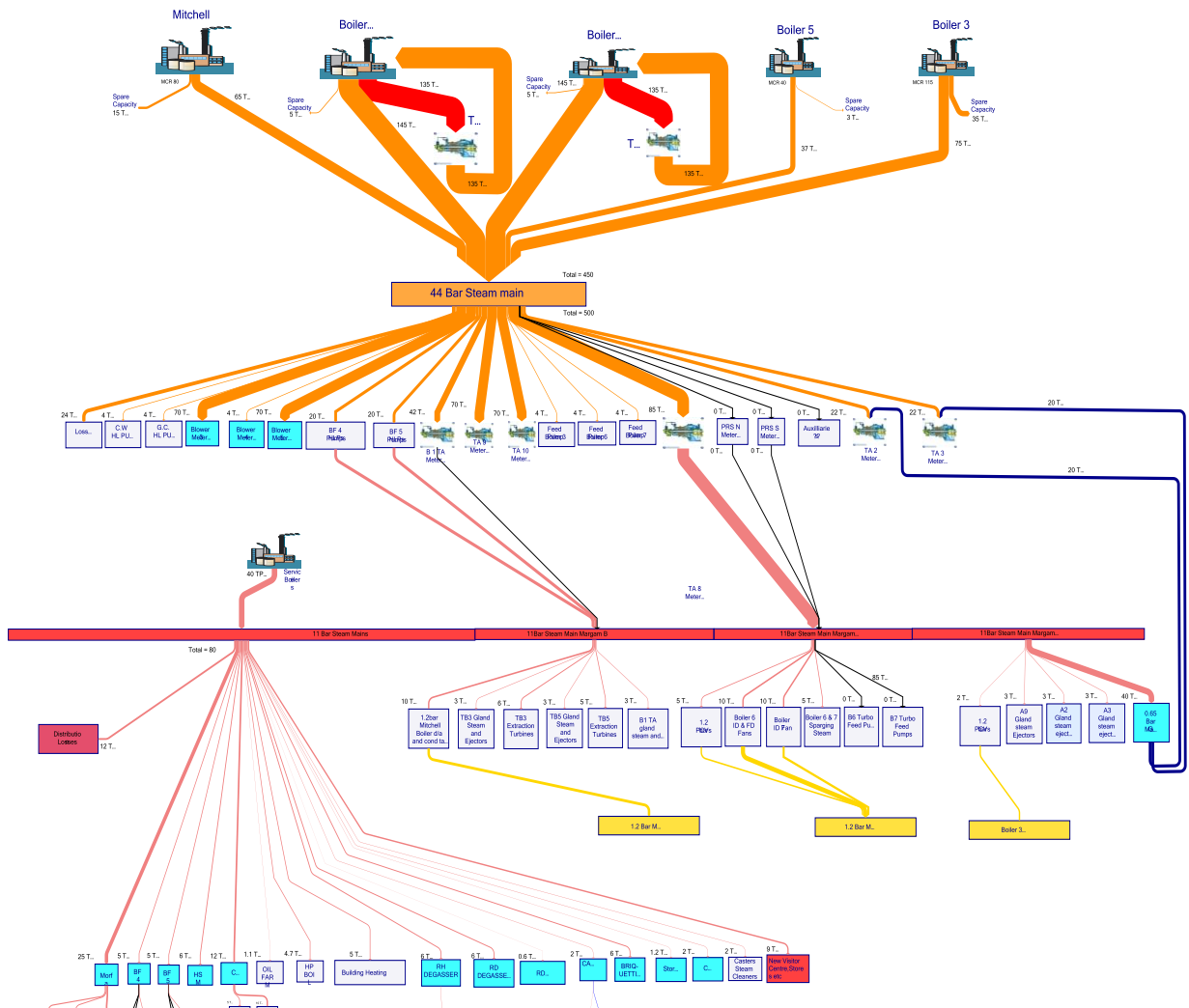

Figure 69 Case Study Works Steam System Schematic

4.5 Possible WHR boilers at the case study works

In chapter 3 the possibility of WHR for the case study works was discussed and identified. Referring to Figure 55, which shows the possible high grade WHR projects that could generate steam for the network and with the calculated total consumption of 11bar steam as shown in Figure 67, it's possible to construct Figure 70. This Figure plots the total consumption of the case study site as the green bar on the left hand side and the amounts of steam generated by possible WHR boilers as red bars. It is therefore possible to deduce that

the works has a possible ‘end use’ for the steam generated. The steam generated by the WHR boilers could be enough to supply the works steam system and in fact supply more steam than the works consumes as shown by Figure 70. This extra steam could feasibly be fed back into the Power Plant for increased electrical generation.

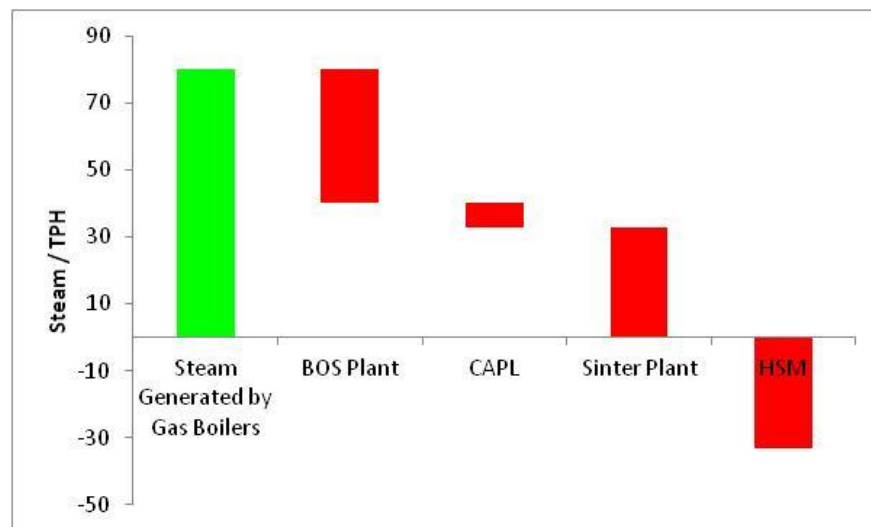

Figure 70 Potential Waste Heat Recovery Bridging Graph

4.6 Loss of electrical generation

The investigation then explored one of the biggest issues with the balance of the steam distribution circuit at the CSSW. The historical development of the case study plant has resulted in an excess of indigenous fuels, which in some cases are continuously flared. Little investment had been made in the power plant resulting in a lack of capacity and an excess of low calorific blast furnace gas. As shown in Figure 71, 11 barg steam is exported from the power plant via a pass-out turbine, thus the higher the demand from the works, the higher the electrical generation of the power plant. If waste heat was therefore used to generate steam for the site, then the power plant would export less steam and reduce its electrical generation. Waste heat projects would therefore have a negative payback.

Defining the optimum ‘end use’ would therefore necessitate a rethink of the case study steam system and power generating philosophy.

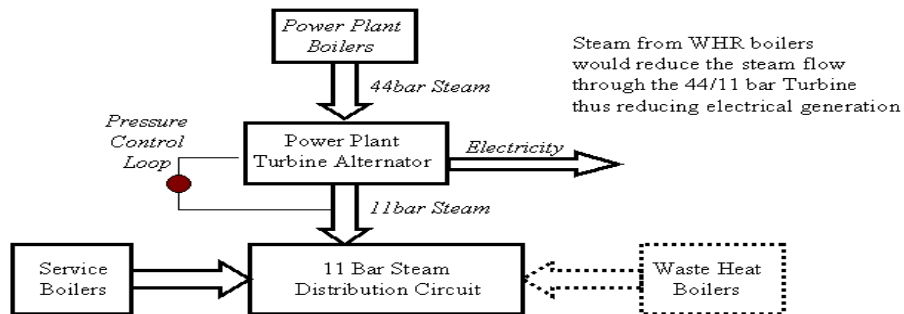

Figure 71 Case Study Works Steam Control Philosophy

As mentioned in chapter 3 the case study works was starting to investigate a new off-gas cooling system for the BOS plant gas.

4.7 BOS Plant WHR investigations

The BOS plant area suffered from continued manufacturing delays from failures of the water-cooled off gas system. Figure 72 shows the ladle pouring 280tonnes of molten iron into the BOS vessel. During the subsequent 20minute process, Oxygen is forced down a lance and into the vessel reacting with the iron and forming steel. This exothermic reaction generates 1500Nm³/h of carbon monoxide gas at 1700°C. This BOS gas then needs to be cooled before it can be cleaned and collected for further combustion in the Power Plant boilers.



Figure 72 Case Study Works BOS Plant Photo

Figure 73 shows the BOS plant and off-gas cooling system and indicated that the 45MWth is cooled via a cooling tower. This off-gas system had been replaced in 1997 but was well beyond its designed lifecycle and thus needed to be replaced. As discussed in Chapter 3 there has been WHR technology available for the BOS plant for decades and therefore it can only be assumed that due to cheap energy prices and the lack of an obvious ‘end use’ the decision was made to opt for the least cost option of a simple ‘open cooling’ water system and not consider the option with heat recovery. Unfortunately, since 1997 the heat extracted from the cooling system was simply vented to atmosphere through a conventional cooling tower.

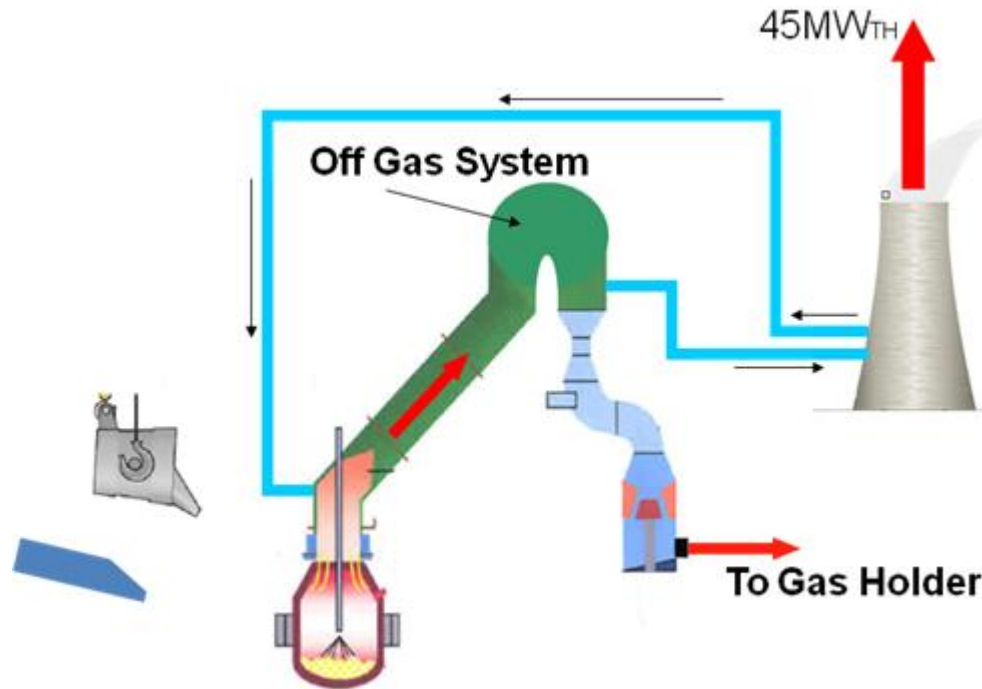

Figure 73 BOS Plant Off-Gas Ducting Cooling

Research has identified the three options available for off-gas ductwork (Kasalo 2010). In principle these options are:

1. Open cooling system. The off-gas ductwork is simply cooled with recirculated water directly from cooling towers. This option results in difficult water chemistry control and resultant corrosion issues.
2. Closed cooling system. The cooling tower is separated from the ductwork with heat exchangers thus improving water chemistry control and reducing the risk of corrosion.
3. Evaporative Cooling. Is essentially using the waste heat to generate steam from the cooling water in a boiler/steam drum assembly. This is the most expensive option but generates considerable quantities of steam.

For the case study works a 'closed cooling' [option 2] was being considered rather than an open cooling [option 1] for the replacement the off-gas system. This would improve the long term water chemistry control and thus extend the life cycle of the off-gas ductwork. The third option of evaporative cooling was seen as technically challenging in terms of installation and as there was not an obvious 'end use' for the steam and so the financial benefits were undetermined. As stated earlier, any steam put into the steam distribution circuit would reduce the electrical generation of the power plant and thus have a negative impact financially.

As discussed by Kasalo (Kasalo 2010) with typical gas flows of 150,000Nm³/min and at temperatures of over 1500 °C for the case study plant it was possible to calculate that at least 23 tonnes of steam is generated per heat at 20-40 barg [depending on the hot metal quantity, oxygen blowing rate and combustion control]. Then depending on the number of heats per hour, steam accumulators can be employed to provide a steady steam export flow. For the CSSW this would average at 1.8 heats per hour so an expected steam export of an estimated 40 tonnes per hour. Also an 'externally fired' Superheater would also be required, since the steam distribution circuit requires superheated steam. The steam export from the waste heat boiler would be saturated. More importantly, as previously described, any additional steam fed into the steam mains would reduce the amount of steam supplied to the site by the power plant and thus reduce the amount of electricity generated. Therefore, exporting steam from the BOS plant into the existing steam distribution circuit, as per the BREF document would not make financial sense. Two options were therefore considered:

1. Fitting a saturated steam turbine alternator [TA] package directly off the BOS steam export line. This would generate a maximum of 5MWe
2. Fitting a superheated steam turbine alternator [TA] by utilising some of the flared BF gas to superheat the steam from the WHR boiler. This would generate a maximum of 7.6MWe and in effect an extra 2.6MWe would be generated with 18GJ [5MWTH] of free fuel.

Both above generation options assume a steady state steam export from the BOS plant. To understand the actual steam export rate a model was developed based on minute-by-minute data from the previous year's operation. The modelled year suffered a weak order book, but was never-the-less seen as what would typically be expected in further weak trading and should therefore be assessed as a worst case scenario. The model included a calculation of steam export based on BOS production rates, with an allowance for steam accumulation and a basic control philosophy was assumed. It then became clear that there would have been a considerable amount of the year with zero steam export and thus no electrical generation. Controlled steam ramp down and up would also have to be considered. The model predicted that BOS would not export steam up to several times a day, in fact in total of about 150,000 minutes or 100days a year could be lost due to intermittent steam export. Figure 74 shows the output of the modelled data and it can be seen that for the majority of the time the generation would be around 3.5MWe. The real concern was the time of zero generation.

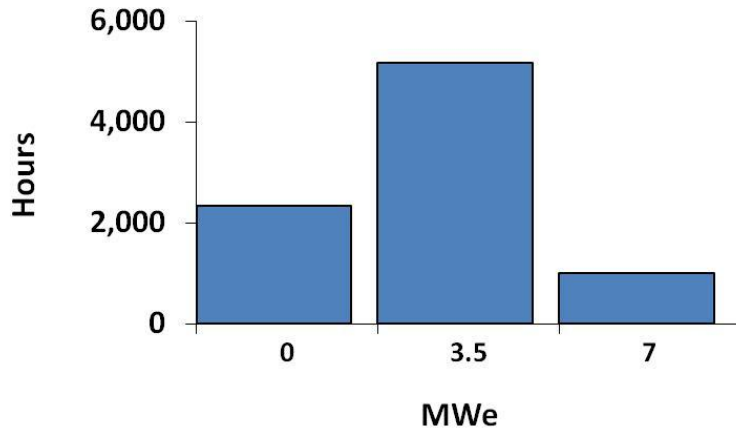

Figure 74 Modelled electrical generation from BOS WHR boiler.

Figure 75 shows the modelled steam generation from the BOS WHR system. The batch profile is clear to see and visually displays the need for steam accumulators. With a low production volume per week at the steel plant the number of steam batches generated per hour would be reduced so the time with zero export would increase.

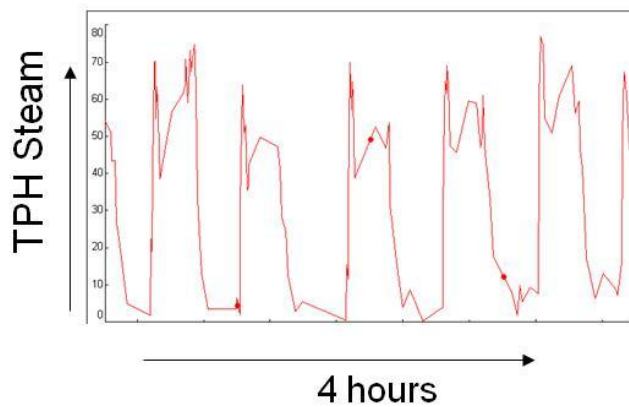

Figure 75 Modelled steam generation from the BOS WHR boiler

Research identified that typical BOS steam export characteristics have been analysed and modelled by Gopalakrishnan et al (Gopalakrishnan et al.2007). They defined the development of a model to improve the capture of steam from a United States BOS plant waste heat recovery boiler. This was defined based on typical steam make per blow and its interaction with the works steam system. It was stated that steam accumulators would be an

essential addition for recovery from the batch BOS plant operation. Atkins (Atkins 2011) explored and calculated the type and size of steam accumulator required for the case study works. The model was then built with an assumed ‘buffer’ from the steam accumulators to simulate a smoothed export. Even with the addition of steam accumulators the model showed there would be regular periods of zero steam export as shown in Figure 76. The figure shows the modelled Oxygen flow to the BOS plant with the resultant steam generation trend. The red line then shows the modelled steam export with accumulators fitted. Even with accumulators it can be seen that regular periods of zero steam export would be experienced.

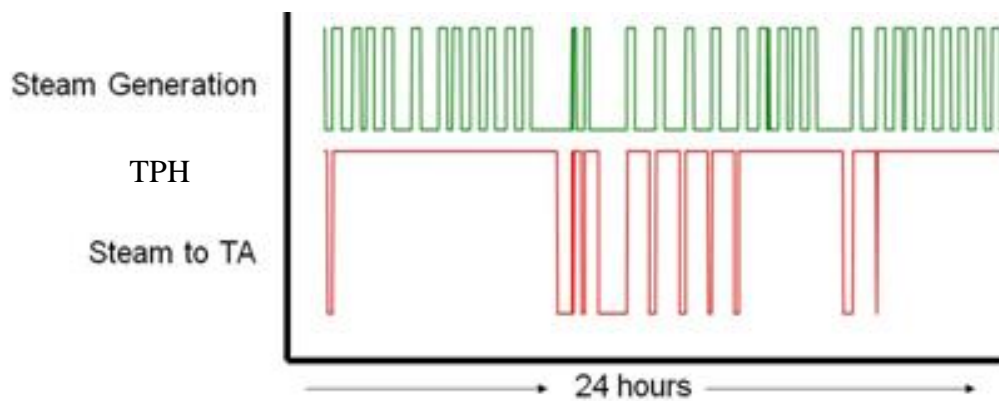

Figure 76 Modelled steam export from the BOS WHR boiler with accumulators

Discussions with potential steam turbine suppliers raised real concerns over the lack of continuity of the supply of steam. Due to thermal stress issues turbines are not capable of coping with frequent periods of no steam. The only practical way of running a turbine would be to supplement the steam from the BOS plant with steam from another source. That way the turbine would always be supplied with a minimum amount of steam and would not be required to stop frequently. Hence, in theory the generation of electricity directly from the BOS steam was possible but in practice, due to the periods of no steam,

was not plausible. The CSSW discounted this option because of concerns over variability and possible manning consequences of having to closely monitor a turbine at the BOS plant. This resulted in the necessity for the consideration of Option 3: Utilising steam from the local steam distribution circuit to supplement the BOS steam make. The project was then developed for a turbine mounted off the steam distribution circuit. The steam from the BOS plant would be pressure reduced and superheated before feeding into the turbine. Should the BOS plant stop making steam then steam would be drawn from the distribution circuit. The amount of electrical generation would drop to 7.2MWe but, due to the additional steam supply from this circuit and generation would be more consistent over the year. So the electrical generation would reduce from 7.6MWe to 7.2MWe, but the turbine would run more consistently and would not have stopped for the modelled 100days per year. This equates to an annual increase of 8000 MWh electricity. So a 0.4MWe loss of potential generation [or 3500MWh over a year] is justified when one considers an additional generation of 8,000MWh is gained by a more consistent operation. To put this into a financial context, for a 50 week year, at £68/MWh the 7.2MWe would be worth £4,100,000 per year. Even though this option does not technically maximise the use of the available energy it does maximise the annual output from the turbine. As the proposal developed it then became clear that the new turbine could also make use of spare steam capacities in the service boilers. The works also has excess gas and flares significant quantities during the year. The service boilers are run at a minimum output to ensure pressures are maintained to the South end of the works, but also maximise the supply from the power plant to ensure maximum electrical generation. By putting a new turbine off the steam distribution circuit this spare capacity could also be utilised to increase the steam make and maximise the financial benefit of the new turbine.

The service boilers had a spare capacity of over 20 tph. The model was then developed further to include an additional 20tph for the boilers that would in effect feed directly into the new turbine. This would increase generation to 10MWe, which with an average works generation of 70MWe, would provide a 14% increase in generation capacity of the power plant. This would require more Blast Furnace Gas [BFG] for the service boilers but for the case study works this is only a proportion of the gas flared and so is available for ‘free’.

In principle the turbine would be kept running using a base load of steam from the distribution circuit and then topped up by steam from the BOS plant waste heat boiler. Figure 77 shows the modelled output of the BOS steam system with the addition of the excess steam from the service boilers. As can be seen the times of zero export have now dropped to zero, thus providing a much more suitable steam source for a steam turbine.

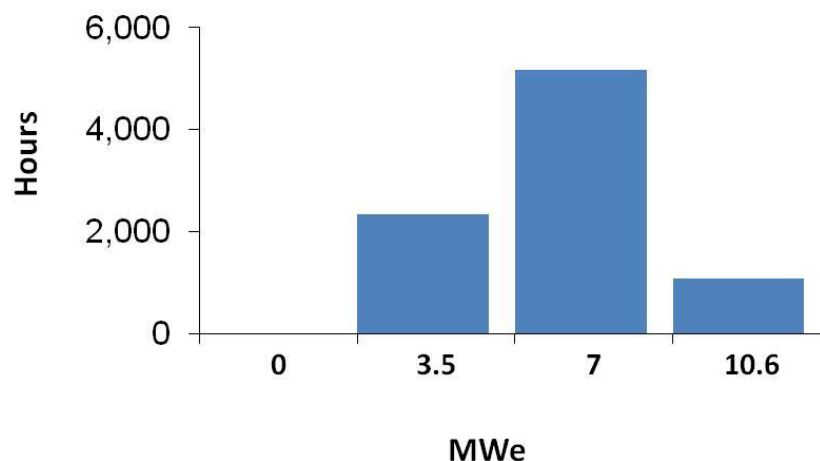

Figure 77 Modelled electrical generation form BOS WHR boiler

The ability then to generate steam from WHR boilers and discharge it into the steam distribution circuit and install a steam turbine off the steam mains starts to introduce other possible benefits:

- The steam export from the power plant could be increased – increasing generation
- Flared gas could be used to further utilise the spare capacity in the Service Boilers
- Distributed steam then becomes valuable and investments in its improvement can be financially justified. For example the 5.5tph of steam identified by Spirax Sarco, during their leaks and losses survey, as defined in section 4.2 would now be worth around £500,000 per year.
- As discussed in Chapter 1 security of electrical supply is a potential issue for UK industry. Using WHR for electrical generation therefore reducing electrical import and thus reducing the risk of ‘black outs’

The author thus developed the steam control philosophy from what was shown in Figure 71 to what is shown in Figure 78. The figure schematically demonstrates the potential new control philosophy of the steam distribution circuit. As can be seen Blast Furnace Gas [BFG] is diverted from the flare to take up spare capacity in the Service Boilers and also as a supplementary fuel for super heating the steam generated by the potential WHR boiler. The new TA is shown off the distribution circuit which is supplied with steam from the

Power Plant, the service boilers and the new WHR boilers.

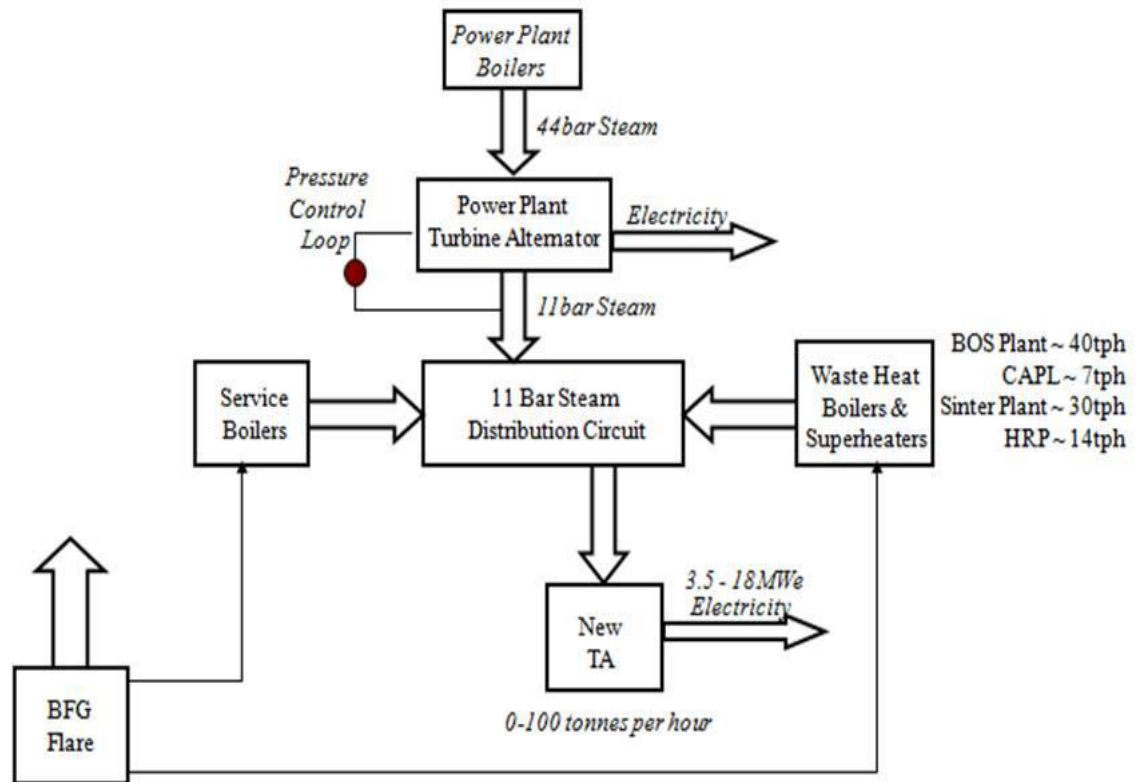

Figure 78 Proposed Steam Control Philosophy

An additional potential benefit that then also becomes evident is the fact that, as shown in Figure 68, 30% of the distributed steam is used for bay, office and process heating. Low grade waste heat could be used to raise hot water and that can be used for Process, Bay and building heating instead, thus displacing the 11bar steam leaving it available for further electrical generation. This strategy will therefore provide a payback for low grade waste heat utilisation. With around 26tph of steam used for process and bay heating the potential savings from increased electrical generation would equate to 4.6MWe generation worth at least £1,000,000 per year.

The new TA with a steam flow to electrical generation ratio of 0.18MWe per tph steam flow then allows one to review Figure 70 and convert the generated steam into potential

electrical generation. Then adding the potential 26tph as 4.6MWe, from the low grade waste heat, it is possible to create Figure 79. As shown it would be possible to generate in the order of 19MWe from WHR boilers and a further 4.6MWe from low grade WHR. The potential 23MWe would equate to a relatively large step change to the case studies on-site electrical generation.

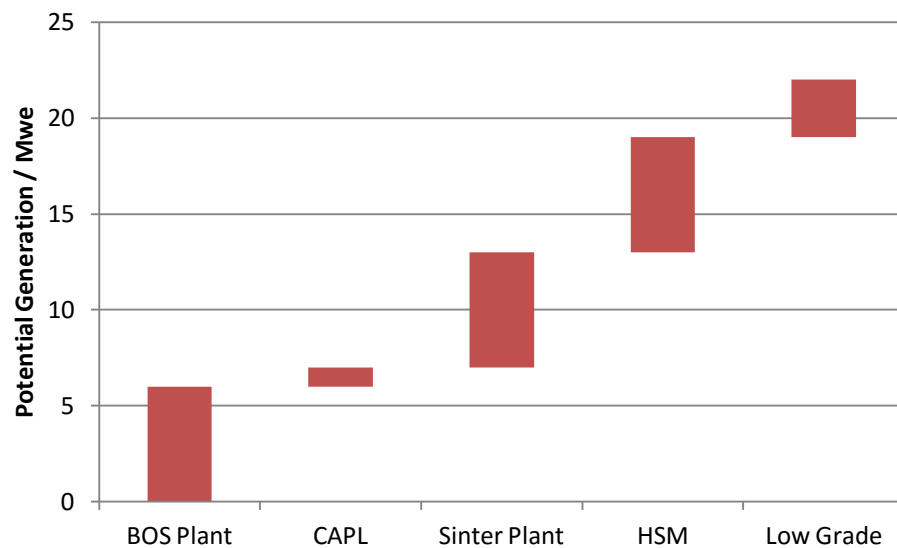

Figure 79 Potential Steam Generation from WHR Projects

Figure 80 shows the relative gain for the case study works in terms of achieving its goal of electrical self-sufficiency. WHR projects are shown as helping to bridge the gap between where the works is now and where it needs to be for self-sufficiency. The works has calculated that through energy efficiency improvements it can potentially reduce its consumption by 30MWe and with a larger Power Plant increase its generation by 60MWe. The figure shows consumption of 200MWe which is the consumption of the case study works and its sister plant at Llanwern. WHR could therefore be key to the sustainability of the UK based steelworks and its sister plant.

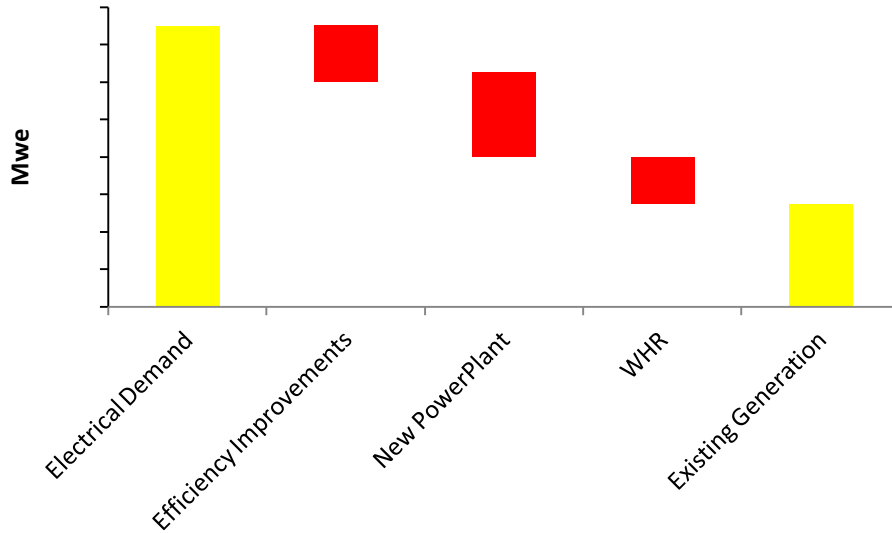

Figure 80 Case Study Works Bridge to Electrical Self sufficiency

4.8 The proposed WHR Strategy

The strategy of installing a TA off the 11bar steam system and utilising WHR boiler to generate steam for electrical generation and low grade waste heat for process and bay heating could transform the energy balance of the works as simplified in Figure 81 and Figure 82. All the indigenous gases could therefore be used to displace Natural Gas imports for furnace heating and increase electrical generation in the power plant. Instead of the waste heat being emitted to the atmosphere it can then be utilised for bay and process heating and also be used for further electrical generation.

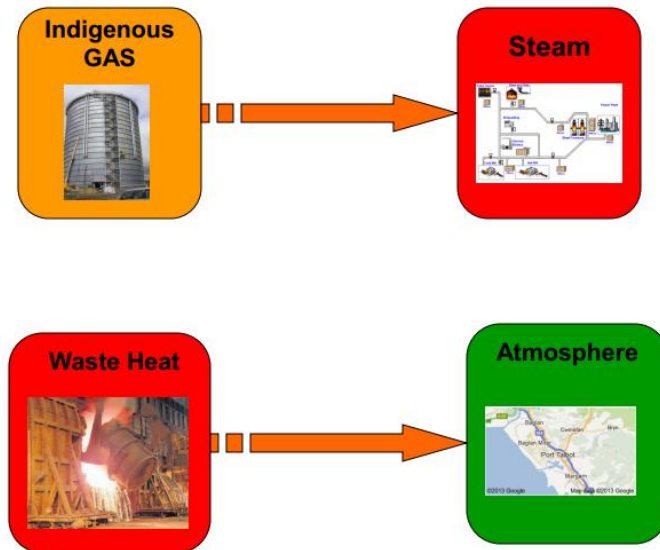

Figure 81: The AS-IS

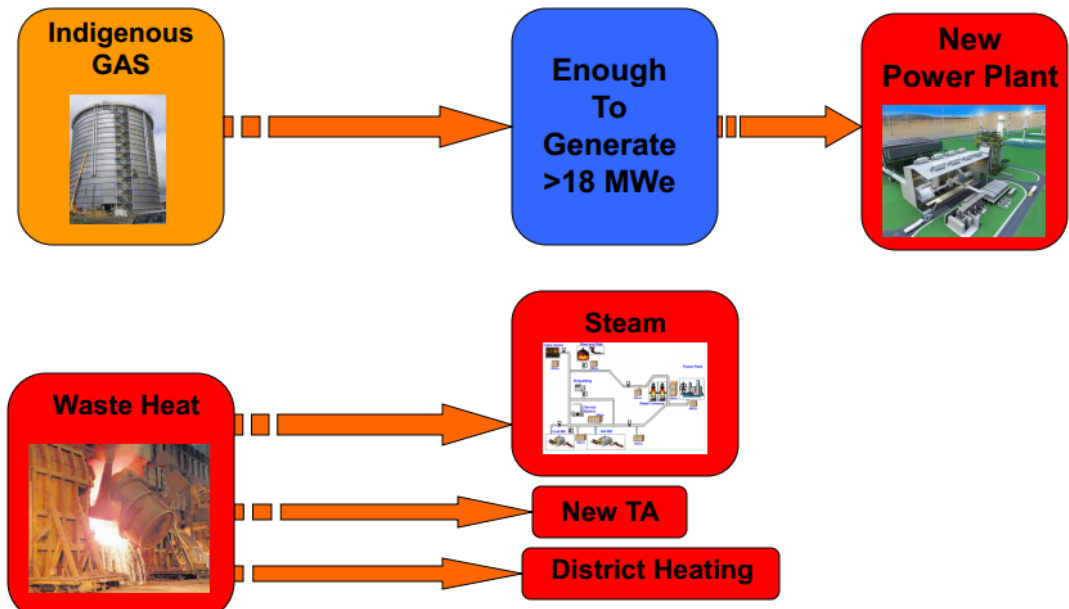

Figure 82 The Proposed Strategy for WHR Utilisation

With a potential 23MWe of generation worth around £13mpa and reducing indirect Carbon emissions by 90,000 tonnes per year the proposed strategy definitely warranted further investigation. The proposed TA installation, off the 11bar steam system, not only provides a payback for high and medium grade WHR projects, but also starts to open up possible business cases for low grade WHR projects.

It should also be noted that at the time of writing this thesis the case study works has received planning permission for an extension to the existing power plant to nearly double its capability by increasing the average generation to 130MWe (Planning 2014).

With the new strategy the 11bar steam distribution system starts to transform from what was seen as an old fashioned part of the works to now an essential tool for the sustainability of the steelworks. To ensure that this strategy is viable it would be prudent to model the system and simulate the addition of the WHR boilers.

In order to model the system the pipe work, insulation, boilers and consumers for the whole of the steam distribution circuit would need to be surveyed and programmed into a fluid modelling software package.

4.9 Summary

This Chapter has described steam distribution at the CSSW and starts to satisfy Aim 3 of the thesis by making an initial understanding the impact of WHR projects on the CSSW. The system at the CSSW has been surveyed by the author and by Spirax Sarco and although the system was found to be in a good condition several areas of improvement were identified and actioned for repair. A mass balance exercise for the CSSW resulted in the production of a Sankey Diagram and Pie Chart of main consumer types. The chapter explains how the steam system could provide an 'end use' for high, medium and low grade WHR projects. With potential benefits identified as being 23MWe, worth £13mpa and a carbon emissions reduction of 90,000tpa. It is concluded that to further understand and assess whether the steam circuit can be used to facilitate the addition of WHR boilers it is necessary to model the whole system. The application of a BOS Plant WHR boiler is modelled from a mass balance perspective and leads to the conclusion that the system

requires a full Thermodynamic and Fluid Mechanic model to understand the full pressure and temperature effect of the potential addition of WHR boilers on the steam system. The next chapter therefore describes the modelling of the steam distribution system.

5 Modelling the Steam Distribution Circuit

5.1 Introduction

This chapter describes the fluid model, developed as part of this research, of the steam distribution circuit for the case study works. Figure 83 maps out the process used to first assess the software, then develop and verify the model. The chapter includes the results from a comparison between manual calculations and predicted results of pressure drop and temperature loss. This is covered by steps A to C in Figure 83. The building of the model is explained in step D along with the models verification against actual plant data for the case study works. To understand possible errors and inaccuracies, a sensitivity analyses was conducted and is described in Step E. The model was then considered to be verified and Chapter 6 then goes on to demonstrate how the model has been applied to assess various Waste Heat Recovery [WHR] case studies.

The first section of this chapter overviews the theory of fluid modelling in terms of pressure and temperature and also includes a comparison between the results calculated by the software package - 'Fluidflow3'(NI 2014), and traditional theory. Initially the theory, with relevant calculation methods, are described and related to actual steam conditions experienced at the steel works. Comparative data was then input into the Fluidflow3 software package and the results compared to the theory. This is, therefore, a simple verification and assurance of the Fluidflow3 calculation techniques.

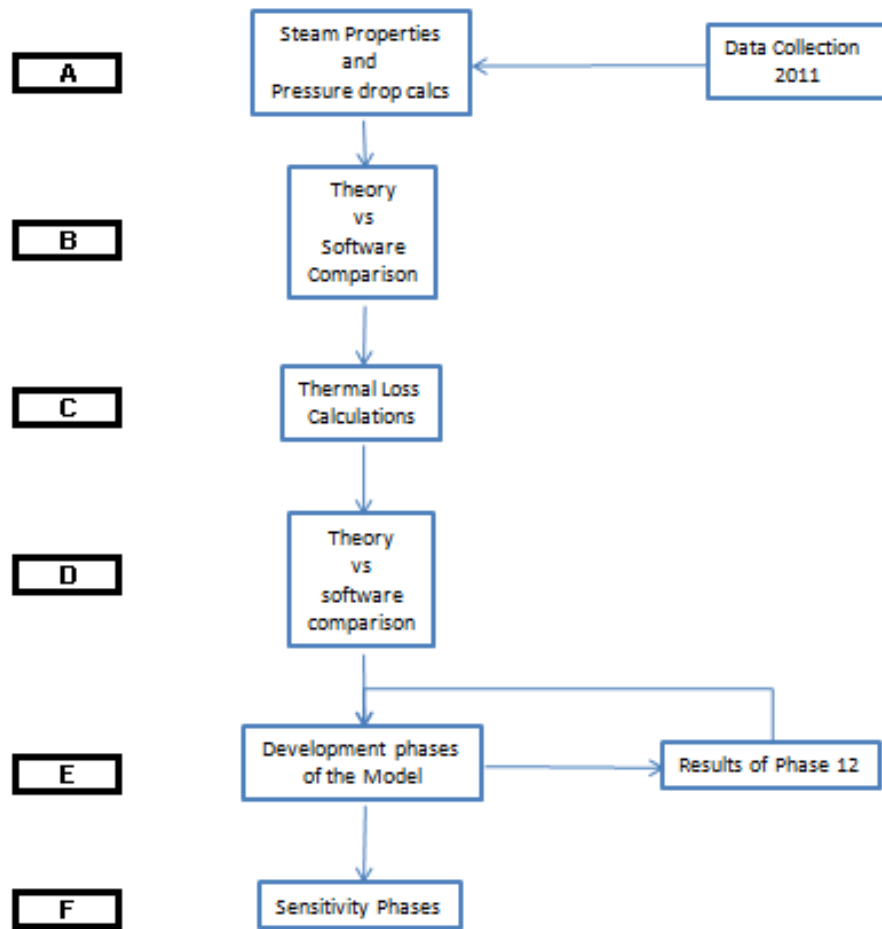

Figure 83: Model development procedural flow chart

5.2 The Software

When analysing steam system modelling, the majority of research refers to mass balance models rather than modelling pressure drop and thermal loss. Even within the US Department Of Energy Guide book, ‘Improving Steam System Performance’ (USDoE 2012), many differing techniques are defined for improving steam system performance, but surprisingly modelling of the pipe work is not discussed. Further research identified a limited number of studies that describe modelling of steam distribution systems. Wood defines the ability of the software package ‘Pipe2000’ to model a pipe work system carrying steam around a college campus district heating system (Wood 2010). The system was modelled with both saturated and superheated steam and the model is used to calculate

the benefits of both options. Schultz (Schultz 2014) describes modelling of the Seattle City steam distribution circuit using the package 'ReCap5-3D'. The software was used to assess the efficiency of the steam system and also simulate extensions to the distribution system. Case et al (Case et al. 1996) describe the development of a spreadsheet based model of an American Air Force Base. The study describes the required iterative nature of the calculations essential for steam modelling. More recently the Fluidflow3 software contains examples of a steam distribution circuit (NI 2014). In fact, on the 1/3/14, the website contains a case study of a superheated steam distribution circuit at 10.4 bar and 300 °C distributed over 14km therefore similar to the system modelled in the current study. With a wider context, two publications are the 'Pipeflow1 and Pipeflow2' publications by Bratland (Bratland 2009, 2010). Both these publications define the advantages and disadvantages of system modelling and describe the various techniques and software used. They are written for engineers as practical guides to modelling pipe work systems.

A number of steam projects based on the CSSW, dating back to the early 1990's, have been undertaken. For example Brown conducted an energy audit of the steam distribution mains (Brown, 1991). The study examines leaks and losses and also considers improvements to the end use consumers of the steam. Although dated, the report provides a good overview of the steam system and makes several recommendations for efficiency improvements. Not many of the recommendations were followed up and it's believed that this was due to cost but also the fact that, as described in Chapter 4, steam savings do not save money for the case study works. In 1992 De Melo (De Melo, 1992, Modelling of an industrial steam distribution system; De Melo, 1992, Modelling of an industrial steam distribution system)(De Melo 1992) modelled the steam system in 'Lotus 123'. The project was to understand what could be done to the distribution system to reduce the pressure drop

between the Power Plant and the Coke Ovens. The report recommended increasing the pipe work size by 2cm to reduce the pressure drop but, due to the potential large capital outlay and the fact that steam savings did not save money, the proposal was not adopted. More recently Chisholm, (Chisholm 2010) produced an overview of the energy losses of the steam distribution system. The report recommends several pipe work modification, improve steam trapping, condensate recovery and decentralisation of the steam system. As the outcome of this report overlapped with the initiation of the current research study none of the recommended work had been undertaken.

Within the steelworks a software package called Fluidflow3 (NI 2014) was already in use. It had been used for indigenous gas flow modelling from the Coke Ovens. Various pipe work modifications had been modelled and also a model had been created for comparison to plant data for monitoring pressure drop due to contamination build up within the pipe. The software was therefore well respected but had not been used, at the case study works, for steam pipe work modelling.

Fluidflow3 software developed by Flite (NI 2014) is described by Accutech (ACCUTECH 2014b) as being 'state-of-the-art software for fluid and process pipe-flow simulation with capabilities including compressible and incompressible flow, heat transfer, multiple and combining fluids within the pipe system, non-Newtonian/slurry flow and 2-phase gas/liquid flow. FluidFlow3 allows you to easily and graphically 'build' a model of a pipe network and simulate the performance of almost any type of line equipment - pumps, fans, compressors, control valves etc. Flows and pressures can be calculated around the network and optionally include heat change calculations for any pipe or component. Different fluids can enter the network at different boundary locations and the software will determine the physical

properties of the mixture where the streams combine. Accutech also publish design notes (Accutech 2014a), a training manual (Accutech 2013b) and a fluid mechanics refresher (Accutech 2013a). These documents provide an overview of the software and its operation. The calculation techniques are defined and recommendations are made on how best to use the package.

Before using Fluidflow3 to model the steam system of the case study works, it was decided that the software should go through a basic validation exercise. The model should be compared against theoretical manual calculations. This would ensure an understanding of how the software operated but also give a defined measure of the accuracy of calculation. To ensure that this exercise was relevant the verification exercise was conducted at the same steam conditions as those experienced in practice. To this end it was necessary to conduct an analysis to fully understand the properties of the steam as it travels around the steam distribution circuit described in Chapter 4.

5.3 Methodology

5.3.1 Pressure Drop

In order to calculate the pressure drop, it was first necessary to calculate the Reynolds number, then use the Colebrook equation and then the Darcy Weisbach Equation (Accutech 2013a).

The Reynolds number [Re] is a dimensionless quantity that gives a measure of the ratio of inertial forces to viscous forces and consequently quantifies the relative importance of these two types of forces for given flow conditions.

$$Re = \frac{\rho v d}{\mu} \quad \text{[Equation 5.3]}$$

For flow in a pipe this can be written as:-

$$\frac{\rho v D}{\mu} = \frac{v D}{\nu} = \frac{Q D}{\nu A} \quad \text{[Equation 5.4]}$$

Where ρ represents density [kg/m^3], μ dynamic viscosity [kg/m.s], ν Kinematic viscosity [which is μ/ρ [m^2/s]], D Diameter [m], Q_v Volumetric flow rate [m^3/s] and A represents cross sectional Area [m^2].

Data from pressure and temperature gauges around the steelworks was analysed and therefore it was possible to fingerprint the steam system to a level never understood before. With the work completed in Chapter 3, the steam system mass balance was more clearly defined, it was then possible to calculate mass flow rates and thus velocities of the steam flow through the worn pipe work. The temperature and pressure trends enabled a more accurate understanding of typical steam density and viscosity values. With steam pressures ranging from 10 to 12bar gauge and temperatures ranging from 280-320 °C it was possible to calculate the range of steam density and dynamic viscosities experienced in the CSSW. From this analysis it was possible to conclude that the steam remains at the superheated state throughout the distribution circuit and therefore, when conducting calculations, it was assumed that the steam can be treated as a compressible gas.

The data analysis showed that the density ranges from 4.31 kg/m^3 and 4.691 kg/m^3 and the viscosity ranged from 3.41 and 5.08 kg/m.s . Thus the 16” worn steam pipe, with a nominal cross sectional area of 0.11 m^2 and the largest mass flow rate of 23tph, flowing to the Coke Ovens, gives a velocity of up to 20.9 m/s . For the smallest consumer, the CAPL at 2.6tph through an 8” steam pipe, gives a velocity of 4.9 m/s . With the velocity varying from 4.9 m/s to 20.9 m/s it is then possible to calculate the range in Reynolds numbers experienced at the various pressures, temperatures, pipe sizes and flow rates within the circuit. The

calculations showed that for the configuration of pipe work and mass flow rates the Reynolds numbers are quickly elevated from laminar to Turbulent flows. A flow as low as 0.1tph sufficient to define the flow as turbulent. Predominantly all flows to consumers can be considered as turbulent and laminar below 0.07tph for the 16” pipe.

Surface roughness was obviously critical in calculating pressure drop (Accutech 2013a). The steam pipe work is decades old and at the time of writing the true value of surface roughness would be virtually impossible to determine. Various sections of pipe suffer differing duties and therefore subjected to differing rates of erosion. It was not possible to gain access to measure the pipe work parameters and so the software developers, Flite, were approached. Their recommendation (Flite 2012) was to use a surface roughness value of 0.05 for superheated pipe work. The Darcy Friction factor, f , was then obtained from the Moody diagram (Moody 1944) or using the Colebrook equations [Equations 5.4 to 5.7]. The Colebrook equations were used to calculate the friction factor for the steam and pipe work at the case study works and are graphically presented in figure 84.

Laminar Flow [Re <2300] :
$$f = \frac{64}{Re} \quad \text{[Equation 5.5]}$$

Smooth Pipe Turbulent Flow [Re>4000]:
$$f = \frac{0.316}{Re^{1/4}} \quad \text{[Equation 5.6]}$$

Completely Turbulent Flow [Re>4000]:

$$f = [1.14 + 2 \log_{10}[\frac{D}{E}]]^{-2} \quad \text{[Equation 5.7]}$$

Transitional Region [Re 2300 – 4000]:

$$f = \{ -2 \log_{10}[\frac{E}{3.7D} + \frac{2.51}{Re[\frac{f}{2}]}] \}^{-2} \quad \text{[Equation 5.8]}$$

Figure 84 shows the results of the calculations and portrays the relationship between the Friction factor and the Reynolds number for the CSSW.

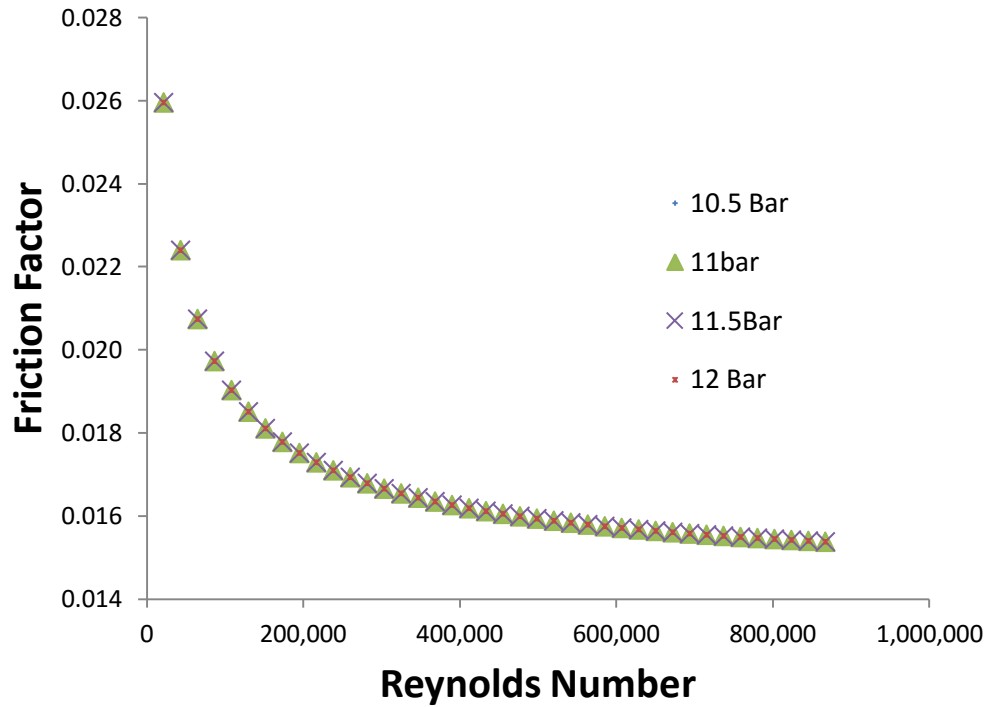

Figure 84 Friction Factors for actual Re for 16” pipe at 320°C

It was then possible to use the Darcy –Weisbach equation to calculate the head loss for the pipe work in the CSSW.

$$\text{Head Loss: } \hat{h} = f \cdot \frac{L}{D} \cdot \frac{V^2}{2g} \quad \text{[Equation 5.9]}$$

Where f represents the Darcy Friction factor, L/D the ratio of the length to diameter of the pipe [m], V the mean velocity of the flow [m/s] and g represents Gravity [m/s^2]. It was then possible to demonstrate the effect of the worn pipe work on the pressure drop. Figure 85 shows the two calculated pressure drops for worn and ‘as new’ pipe work. It is clear to see that for lower flows the pressure drop difference was relatively small, but as the flows increase then so does the differential as would be expected.

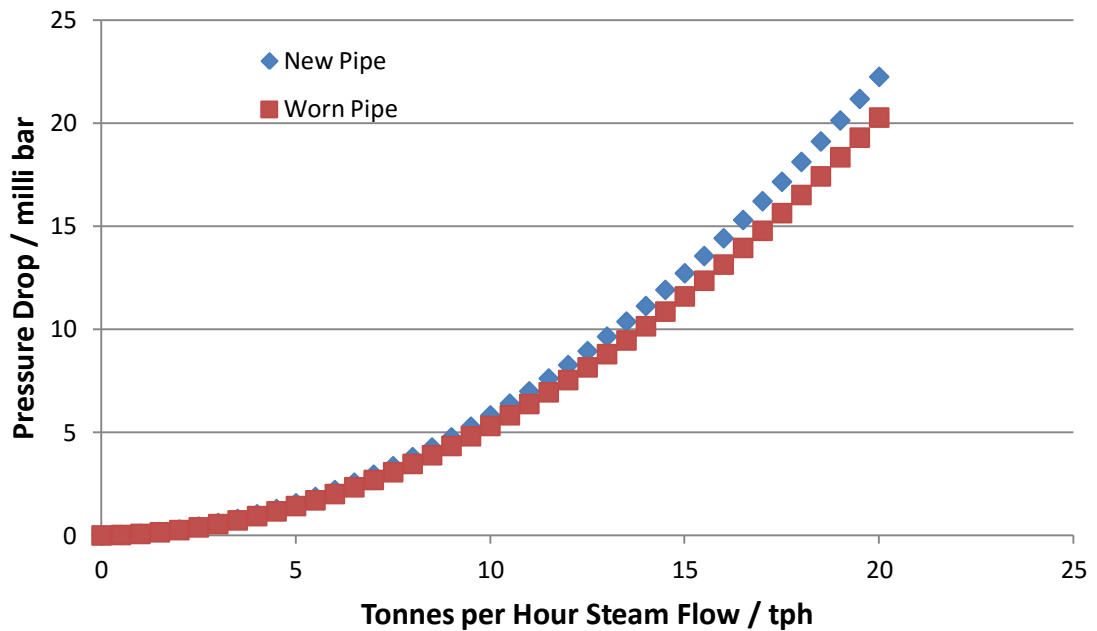

Figure 85: 16” New pipe vs Old Pipe comparison 200m 16” NB pipework

For pipe fittings, joints and connections Fluidflow3 allows the user to select the calculation method. The more common way is that defined by Crane (Crane 1982). Crane though does not enable calculations for unequal tees, t junctions other than 90 degrees and it does not account for all of the pressure variations witnessed within a t junction. More complex methodologies developed by Miller (Miller 1978) and Idlechik (idlechik 1960) more accurately calculate head loss across tees, bends and fittings. The software developers in fact have recommended, in the training manual (Accutech 2013b), that for steam systems that the Miller methodology be used for bends and valves and that Idlechik methodology be used for Tees. The software package contains a database of manufacturers declared characteristics of the pipe fittings, valves and pumps. It is therefore possible to access the information directly from the software.

Accutech in their design notes (Accutech 2014a) recommend that head losses across junctions are often referred to as “minor losses”, implying that they are small compared to other losses in the system. However, compared to pipe friction, equipment items and static head this is not always the case. The relative importance of the various losses in the system should be kept in mind when designing a system. As the intention is to model the 26km of pipes of the case study works the relevant importance of pipe friction to junction losses will be unknown. Due to the age of the distribution system the exact characteristics of the bends, junctions and tees are unknown and so is the internal surface finish of the pipes. Therefore when building the model the parameters recommended in the software are a suitable starting point for comparison between the modelled results and actual plant data.

5.3.2 Results of the Software vs Theoretical comparison

The next phase was to compare the manual calculations for pressure drop to those predicted by the software Fluidflow3. Lengths of pipe work with differing steam conditions were analysed. The software runs the necessary calculations and presents the results on the screen or via export to Excel. Manual calculations were also conducted for pressure drop. Various pressures and temperatures of steam were used and are tabulated in Table 9. The results of both the software and manual calculations are shown and compared as the percentage difference.

Table 9: Comparison between actual and Modelled Data

	Model Head Loss	Calculated Head Loss	Error	Error
	mbar	mbar	mbar	%
11bar 320°C 1tph new pipe	0.08	0.08	0.0	0.00
11bar 320°C 10tph new pipe	5.57	5.58	0.0	0.05
11bar 320°C 20tph new pipe	21.38	21.31	0.1	0.19
10.5bar 320°C 1tph new pipe	0.08	0.08	0.0	0.00
10.5bar 320°C 10tph new pipe	5.82	5.82	0.0	0.06
10.5bar 320°C 20tph new pipe	22.33	22.26	0.1	0.21
11bar 320°C 1tph worn pipe	0.07	0.07	0.0	0.00
11bar 320°C 10tph worn pipe	5.08	5.09	0.0	0.05
11bar 320°C 20tph worn pipe	19.48	19.42	0.1	0.18
10.5bar 320°C 1tph worn pipe	0.07	0.07	0.0	0.00
10.5bar 320°C 10tph worn pipe	5.31	5.31	0.0	0.05
10.5bar 320°C 20tph worn pipe	20.35	20.28	0.1	0.19

Figure 86 shows the percentage difference between the manually calculated values and the predicted. As can be seen the maximum was 0.22% difference.

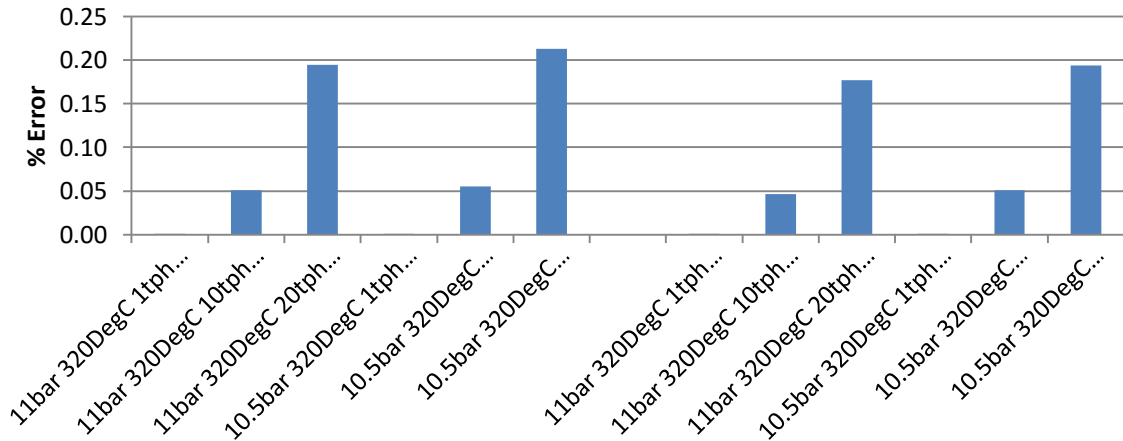

Figure 86 Software to manual calculation error

Thus at an 11barg operating pressure the predicted value would vary to manual calculation by approximately 0.025barg which was within the accuracy of a typical pressure transducer

of 0.5% as defined by Dwyer Instruments (Dwyer Inst 2014). Hence to put this into perspective, the difference between the manually and the predicted calculated pressure would equate to only 13mbar over 26km of pipe work for the case study works.

5.3.3 Methodology : Heat Loss Calculations

As for the pressure loss calculation there was a need to understand how the software determined heat loss calculations and hence undertake another comparative exercise. This comparison was conducted and the findings based on insulated and un-insulated pipes were reported (Houghton 2012). The report specifically utilises steam conditions at the case study site. The site has a mix of older Asbestos and the newer Mineral Wool insulation which perform very differently. Thickness and types of insulation were discussed and it was recognised that there were some records showing which sections of the main are asbestos and which are mineral wool, but generally the percentage split was unknown. As mentioned earlier in the chapter Chisholm (Chisholm 2010) produced a report detailing the energy losses in the CSSW steam distribution system. Chisholm details the insulation types and calculates energy losses and states an assumption of a 80% mineral wool and 20% asbestos split. Both Houghton et al and Chisholm calculate convective, radiative and conductive heat loss using differing pipe diameters, insulation types and insulation thicknesses.

The core equations used are based on Fouriers law, Newtons law of cooling and Stefans law (Bratland 2009) :-

$$Q = \frac{2\pi L[T_{steam} - T_{amb}]}{U} + 2\pi\epsilon\sigma r_4 L [T_4^4 - T_{amb}^4] \quad \text{Equation 5.10}$$

$$\text{Where } U = \frac{1}{h_{steam}r_1} + \frac{\ln[r_2/r_1]}{k_{pipe}} + \frac{\ln[r_3/r_2]}{k_{insulation}} + \frac{\ln[r_4/r_3]}{k_{pipe}} + \frac{1}{h_{air}r_4} \quad \text{Equation 5.11}$$

Q relates to Heat Energy, r_{1-4} radius, k Coefficient of thermal conductivity, T temperature, ε emissivity, σ Stefan-Boltzmann constant and L represents length. h_{steam} is calculated from the use of Rayleigh, Nusselt, Reynolds and Prandl numbers (Bratland 2009)

The software package Fluidflow3 (Accutech 2014a) uses the technique detailed below:-

$$\frac{Q}{L} = \sum \Delta T / [R_i + R_w + R_{LAG} + R_o] \quad \text{Equation 5.12}$$

Where:-

R_i is the inside film resistance and $R_i = 1/[H_i\pi D_i]$ where H_i is the inside film coefficient of heat transfer, R_w is the wall resistance and $R_w = X_w/[K_w\pi D_w]$ where X_w is the pipe wall thickness, K_w is the thermal conductivity of the pipe wall and D_w the log mean diameter of the pipe wall

R_{LAG} is the lagging/insulation resistance and $R_{LAG} = X_L/[K_L\pi D_L]$ where X_L is the insulation thickness, K_L is the thermal conductivity of the insulation material and D_L is the log mean diameter of the insulation. R_o is the outside film resistance and $R_o = 1/[H_o\pi D_o]$ where H_o is the outside film coefficient of heat transfer. Fluidflow3 calculates the individual convection and radiation coefficients which are then summed to give a combined outside/surface film coefficient ie $H_o = h_{rad} + h_{conv}$

The outside film radiation heat transfer coefficient is calculated from the equation

$$h = [\sigma\varepsilon[T_{fluid}]^4]/[T_{fluid} - T_{Ambient}] \quad \text{Equation 5.13}$$

Where h_{rad} is the radiation heat transfer coefficient [W/m^2K], σ is the Stefan-Boltzman constant [$5.67 \times 10^{-8} W/m^2K^4$], ε is the surface emissivity, T_{fluid} is the temperature of the flowing fluid [K] and $T_{ambient}$ is the local ambient air temperature [K].

The outside film convection heat transfer coefficient for ‘above ground’ pipelines is calculated from equations based on ASTM standard C680 (ASTM, 2014)

$$h = C \left[\frac{1}{d_o} \right]^{0.2} \times \left[\frac{1}{T_{avg}} \right]^{0.181} \times [T_s - T_{Amb}]^{0.266} \times [1 + 1.277[Wind]^{0.5}]$$

Equation 5.14

Where h_{conv} is the convective heat transfer coefficient [$W/m^2/K$], C is the constant depending of shape and heat flow direction [1.016 for horizontal pipes and 1.235 for vertical pipes], d_o is the outer diameter [including insulation if present], T_{avg} is the average air film temperature, average of outside and ambient temperatures [$^{\circ}C$], T_s is the outside surface temperature [$^{\circ}C$], T_{Amb} is the ambient Temperature [$^{\circ}C$] and $Wind$ is the wind speed [mph].

Hence comparing equation 5.10 and 5.11 with equations 5.12, 5.13 & 5.14 it becomes clear that the Fluidflow3 calculation is significantly more extensive than manual calculations.

Combined with the processing ability of the software, Fluidflow3 is therefore more likely to provide a more accurate result as it reiterates the calculation as the steam properties change around the distribution system.

5.3.4 Results of the Heat Loss Software vs Manual Calculation Comparison

Houghton (Houghton 2012) compares manual theoretical calculations with Fluidflow3 derived results. Houghton reports a good correlation between theory, model and the manual calculations and estimates a maximum error of 6% between the calculation methods using a 100mm insulation thickness as the reference point. Houghton does not identify the difference in calculation techniques in the conclusions. It was believed that this error was partially due to the ability of Fluidflow3 to constantly reiterate its calculation around the steam conditions, whereas the manual calculation assumes fixed steam properties along a pipe length.

A fact of major note was that, due to the condition of the insulation, identified by both the Giles et al (Giles 2011) study and Spirax Sarco (Sarco 2012), there are several sections of insulation missing and in combination with the unknown split between asbestos and mineral wool, when it comes to modelling, some 'corrections' are to be expected. When developing the model it will be initially assumed that the system was insulated with 100mm of mineral wool. Subsequently, following the reported studies, the insulation data was corrected in the model.

5.3.5 Conclusions of Software vs Manual Calculation

Good correlation was shown between the software, Fluidflow3, and manual calculations, thus giving confidence in the results that the model produces.

Some learning points of this part of the study were:-

- a) The pipe work internal diameter varies due to age and wear rates

- b) The surface roughness is unknown but the software developer recommends 0.05 for super heated steam flow
- c) Component pressure drops are unknown
- d) The quality of the insulation varies significantly due to the age and material type.

To overcome these issues it was therefore a requirement that certain assumptions were made at the beginning of the modelling process. It was therefore necessary to develop the model and compare it against actual plant data. The model therefore needed to go through a verification process to ensure the assumptions are both accurate and appropriate.

5.4 Construction of the Fluid Model

This section describes how the model was created in Fluidflow3 and how it was then verified by comparing it to actual plant data for various different scenarios. There are only a few drawings in existence of the steam system and some areas of pipe work are complex and very difficult to access. Furthermore, these were neither dimensioned or to scale. Starting from 'Phase 1' of the model, modifications had to be made as investigations improved the accuracy of the model compared to plant data.

5.4.1 Methodology

Utilising a laser distance gauge, callipers and a tape measure the steam distribution pipe work was manually surveyed. Google Earth was also used to help track the steam mains around the steel works. Manual sketches were prepared and used as initial input data. It was identified that several of the pre-existing drawings were incorrect so the whole works had to be surveyed. Some areas were difficult to access and so were initially estimated and then improved as more data became available.

5.4.2 Model Build

After many months of surveying ‘phase 1’ of the model was built within Fluidflow3. Figure 87 shows a Google Maps screen print with a simplified overlay of the 11bar steam distribution circuit.



Figure 87 Schematic of Case Study Steel Works Steam System

Each section of pipe had its dimensions and physical characteristics entered into the software model. Figure 88 shows an example of the data entry palette for a section of pipe work. The figure shows the relevant input parameters that the software requires to calculate pressure and thermal losses.

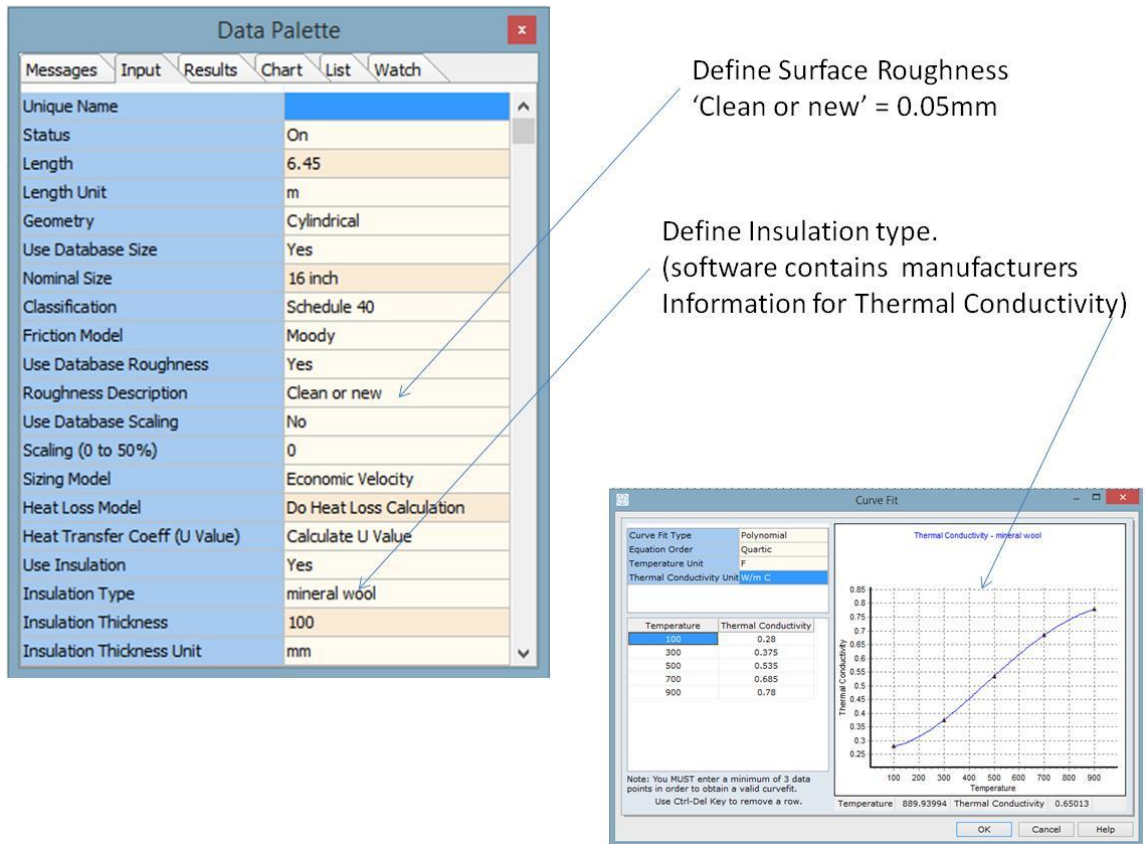



Figure 88 : Fluidflow3 Pipe Data Pallet

The pipe work dimensions were measured using a laser distance gauge. However in some areas, the layers of insulation and cladding on the pipe work made this process difficult but reasonably accurate dimensional measurement was achieved [typically +/- 10mm]. The total length of pipe exceeded 26km and so this took several months to complete. As far as diameters are considered the main sections of the steam circuit have imperial units and therefore were identified as being 16", 12" and 8" Schedule 40 pipe as shown in Table 10.

Table 10: Schedule 40 pipe dimensions

(Source: (Sarco 2014))



Nominal Pipe Size		Pipe O.D.		Wall Thickness	
In.	mm	In.	mm	In.	mm
8"	(200)	8.625	(219.1)	.322	(8.2)
10"	(250)	10.750	(273.0)	.365	(9.3)
12"	(300)	12.750	(323.8)	.406	(10.3)
14"	(350)	14.000	(355.6)	.437	(11.1)
16"	(400)	16.000	(406.4)	.500	(12.7)
18"	(450)	18.000	(457.2)	.563	(14.3)
20"	(500)	20.000	(508.0)	.593	(15.1)
24"	(600)	24.000	(609.6)	.687	(17.4)

To comply with pressure regulations and record levels of pipe wear periodical pipe thicknesses measurements are undertaken. These thickness measurements show a typical reduction in wall thickness, for example for 16” pipe work with an original 12.7mm thickness [0.500” as shown in Table 10], down to 9.2mm. This results in a maximum internal pipe diameter increase from 381mm to 388mm. Regarding surface finish, for ‘phase 1’, a surface finish of 0.05 was selected. This decision was made on the advice of Flite (Flite 2012) who stated that in their experience for superheated steam the internals of the pipe remain smooth as the flakes of rust are removed by the erosion of the steam flow.

For ‘phase 1’ the pipe was entered as fully insulated with 100mm of mineral wool Insulation. Areas of poor or missing insulation were omitted from phase 1 and added at further phases of the model development.

The model was then created by using the relevant parameters. Figure 89 shows the completed model. The Figure also identifies the location of the key data points. These are the points highlighted in red text that data is gathered and used for the model validation.

The black text boxes are the additional points used for further comparisons. These points are also used for manual validation by thermal imaging to confirm steam temperature for the various scenarios. Figure 89 also shows the new meters that were installed and discussed in Chapter 4. Data from these meters was essential in deriving the correct mass balance of the circuit for the various scenarios listed in Table 11. In very initial trial runs of the model it was identified that the spread of mass flow was incorrect between the North and South ends of the works and created large pressure errors. It was found that the system acted like a 'balance weight'. More mass flow at one end of the works tipped the balance and altered the pressure. The new meters acted as a quantifiable check of North to South mass flow.

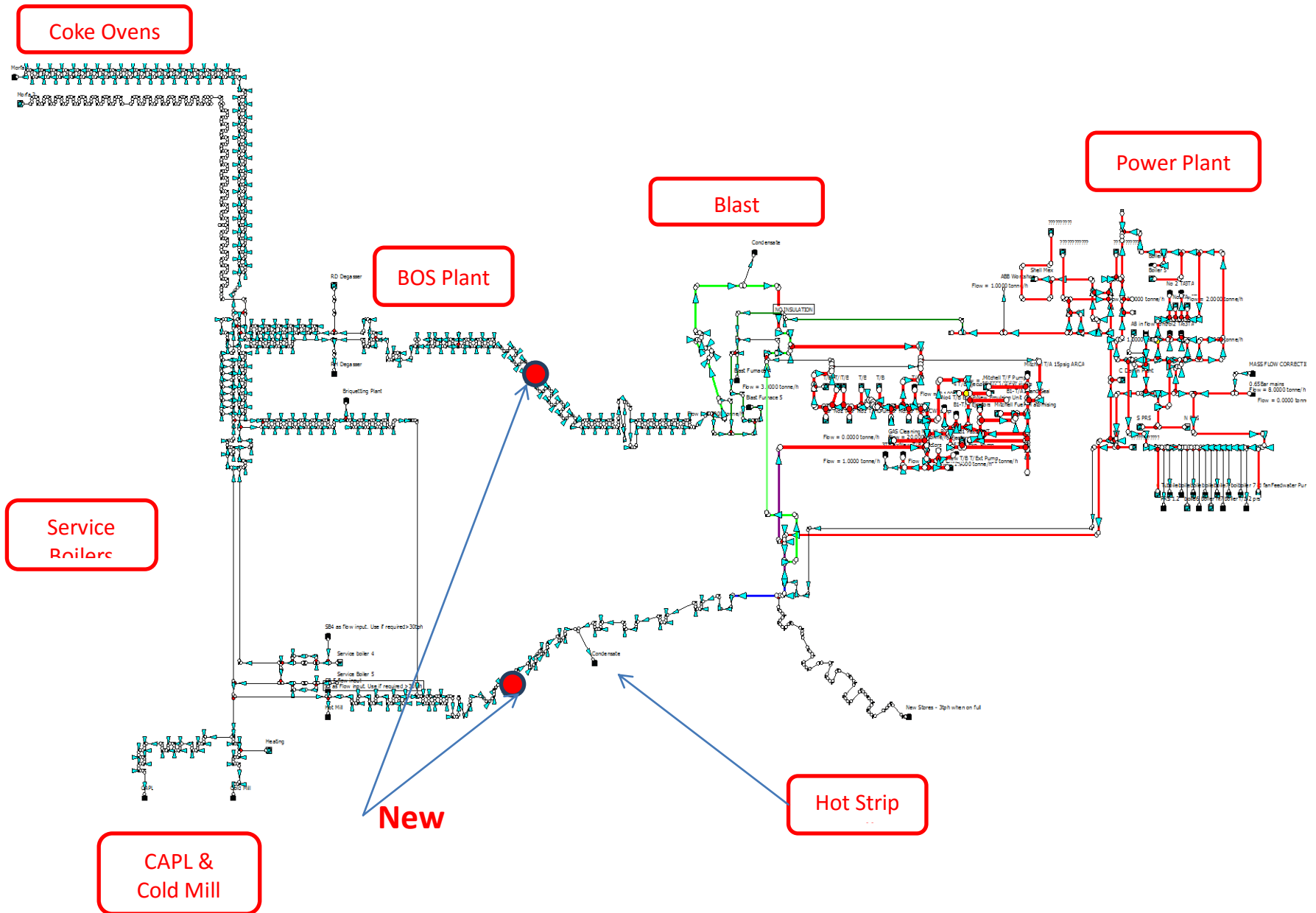

Figure 89 Screen Print of the Fluidflow3 Model

Figure 90 shows the power plant area of the works indicating just how complex the system is. The blue squares are the ‘boundaries’ of the system, that is, the inputs and outputs. The boundaries in the power plant are the Turbine Alternators [TA] and boiler ancillaries [ie pumps and fans, De-aerator supplies etc). Referring back to chapter 4, section 4, and the Sankey diagram shown in Figure 69 it is possible to see the number of steam consumers in the power plant alone. The option of replacing all the power plant consumers with one simulated consumer named ‘Power Plant Total Consumption’ was considered, but it was found that this was not possible. The pressure drops around the intricate pipe work for the differing boilers and consumers had a major effect on the balance of the whole model in terms of pressure drop and flow direction. It was therefore deemed necessary to survey and draw the pipe work.

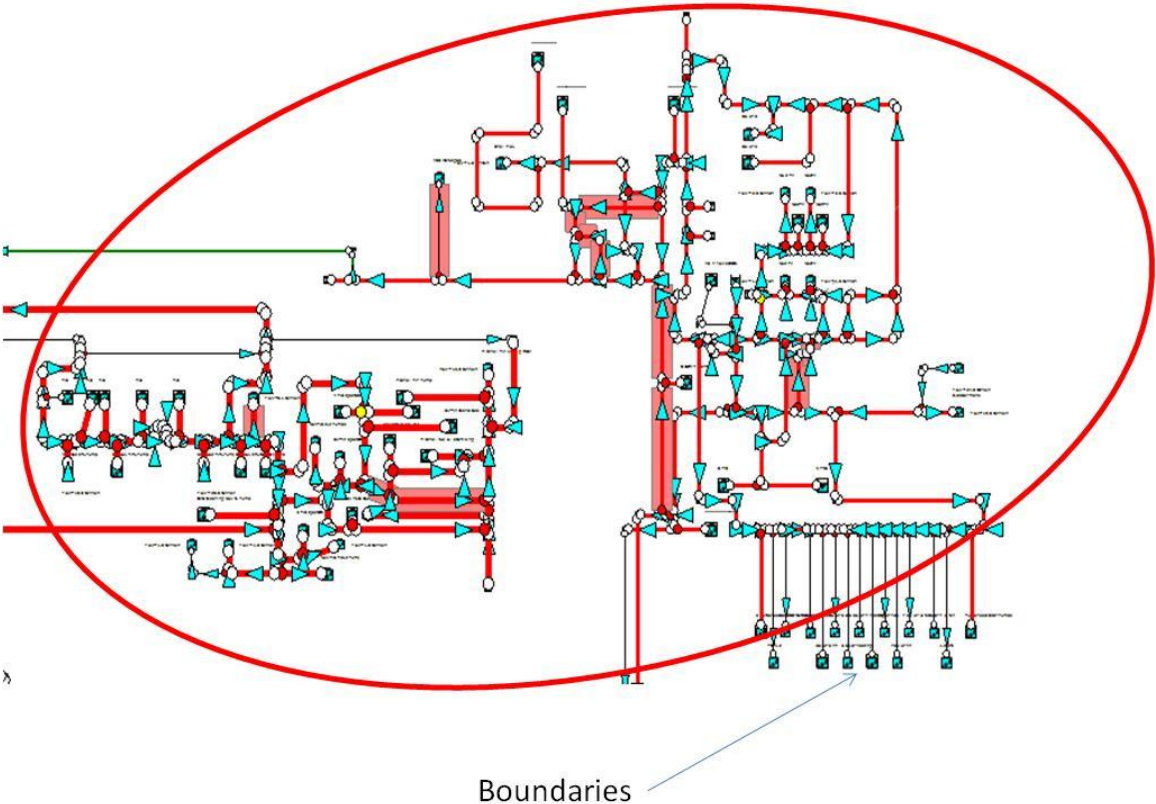

Figure 90 Power Plant area of the 11bar steam system

5.5 Validation of the Model with Plant Data

In order to determine the methodology for the verification of the model a series of scenarios that would represent the whole operating range of the 11bar steam system consumers was considered. The scenarios selected are presented in Table 11, the Table lists the 11bar steam consumers and generators against the selected scenarios. The scenarios represent the differing configurations for the steam system. The consumption for the various consumers was varied and a summer/winter effect stipulated. Plant data was then gathered for the selected scenarios and also a software model was created for each scenario. The ten scenarios were then saved and the results recorded.

Table 11 : The Scenarios (all units in TPH)

	Summer	Winter	Winter	Summer	Summer	Summer	Summer	Winter	Winter	Summer
Degasser	OFF	ON	OFF	OFF	ON	ON	OFF	ON	ON	OFF
	2*BF	1*BF	2*BF	2*BF	2*BF	2*BF	2*BF	2*BF	2*BF	2*BF
Boiler off	NO	NO	NO	NO	YES	NO	NO	NO	NO	NO
Scenarios										
Scenarios	1	2	3	4	5	6	7	8	9	10
Service Boiler 4	20	50	40	40	50	30	40	45	35	25
Service Boiler 5	20	50	40	40	50	30	40	45	35	25
BOS Plant Export	0	0	0	0	0	0	0	0	0	0
CAPL WHB Export	0	0	0	0	0	0	0	0	0	0
Total	40	100	80	80	100	60	80	90	70	50
TA8	71	88	90	80	0	98	78	108	94	74
BF4 HLP	10	20	20	20	20	0	0	0	0	0
BF5 HLP	20	20	20	20	20	20	20	20	20	20
RV	0	0	0	0	20	0	0	0	0	0
Total	101	128	130	120	60	118	98	128	114	94
Coke Ovens	25	25	25	25	25	25	25	25	25	25
CRP	12	15	15	18	12	15	15	15	15	12
HSM	6	6	6	6	6	6	6	6	6	6
Briquetting	6	6	6	6	6	0	0	0	6	6
Degasers	0	20	0	0	20	20	0	20	20	0
BF	12	6	6	6	6	12	12	12	12	12
Losses	6	10	10	6	8	6	6	6	3	6
Heating	0	20	20	0	0	0	0	20	20	0
Total	67	108	88	67	83	84	64	104	107	67
Boiler 6 aux	19	19	20	23	0	23	23	23	22	22
Boiler 7 aux	19	22	23	22	23	22	22	22	19	19
Boiler 3 aux	8	11	14	0	14	14	14	14	8	8
Boiler 5 aux	3	5	5	5	5	5	5	5	3	3
Mitchell aux	6	10	10	8	10	10	10	10	6	6
Obar main	19	13	50	75	25	20	40	40	19	19
New TA	0	0	0	0	0	0	0	0	0	0
Total	74	80	122	133	77	94	114	114	77	77
Total Produced	141	228	210	200	160	178	178	218	184	144
Total consumed	141	188	210	200	160	178	178	218	184	144

All Units in tonnes per hour (TPH)

The plant data was gathered from the works Plant Information [PI] system. This system enables the collection of data from virtually any instrument in the works. The data was exported into excel when required. The data does require interpretation and checking to make sure that it does represent the reality. For example if a meter fails then the last recorded value will be archived as a continuous reading thus making it important to scrutinise the data before further analysis. The process shown in Figure 91 was initiated to aid data collection. The instruments providing the data are regularly calibrated. The calibration techniques and frequencies are managed through a maintenance management system. The calibration frequencies vary around the works areas, depending on duty and environment, but all use United Kingdom Accreditation Service [UKAS] accredited calibration equipment.

A full years worth of data from 2011 was downloaded from the works PI system into an excel spreadsheet and analysed in monthly batches. The data for each month was filtered by the mass balance scenarios listed in table 11. The data was also filtered for obvious meter malfunctions, gross errors, and mean values were transposed into a model validation spreadsheet.

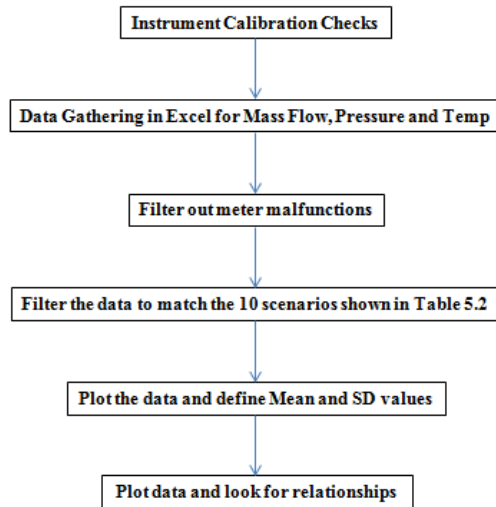

Figure 91: Data Analysis Flow Chart

Bell curves were plotted for the data to assist in validating the data. As an example Figure 92 shows the spread of Pressure data at the Coke Ovens for Scenario 1. With a mean value of 10.63 bar, a range of 0.05bar and a SD of 0.01 it can be concluded that the pressures experienced on the steam distribution system, as it changes through the scenarios, is repeatable and predictable.

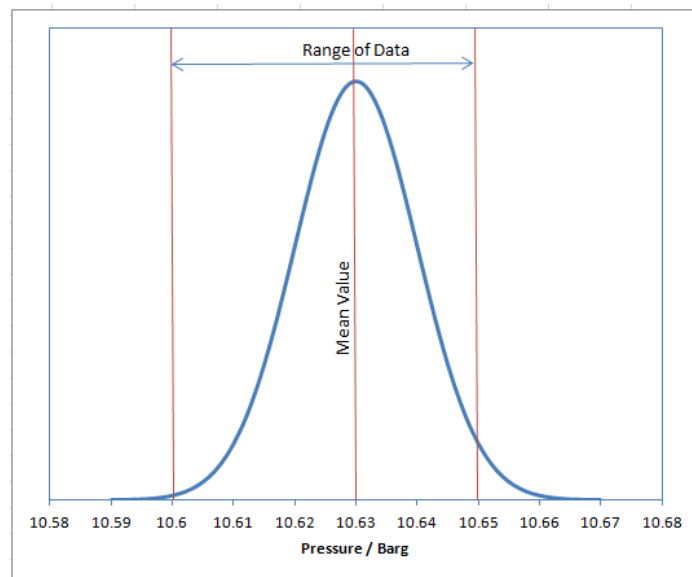

Figure 92 Bell curve for actual Power Plant pressures for Scenario 1

The maximum standard deviation for all ten scenarios are plotted in Figure 93. As can be seen scenarios 1,6,8 and 10 have the largest deviation but at a maximum of 0.07 this is considered acceptable when analysing a system of such size.

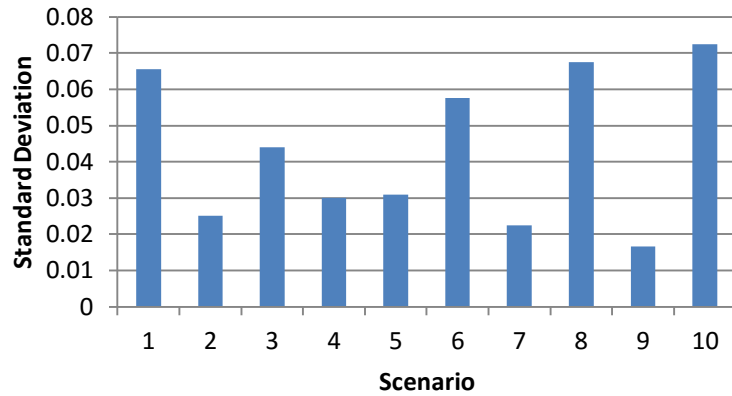

Figure 93 Maximum Standard Deviation per scenario

An alternative way to present the variability of data is shown in Figure 94. As can be seen the plant data varies by up to 1.8% around the mean at the Power Plant area of the works. Due to the large number of unmetered consumers within this area it is therefore hypothesised that variability in Power plant consumers effects the variability of pressures experienced at the Power Plant.

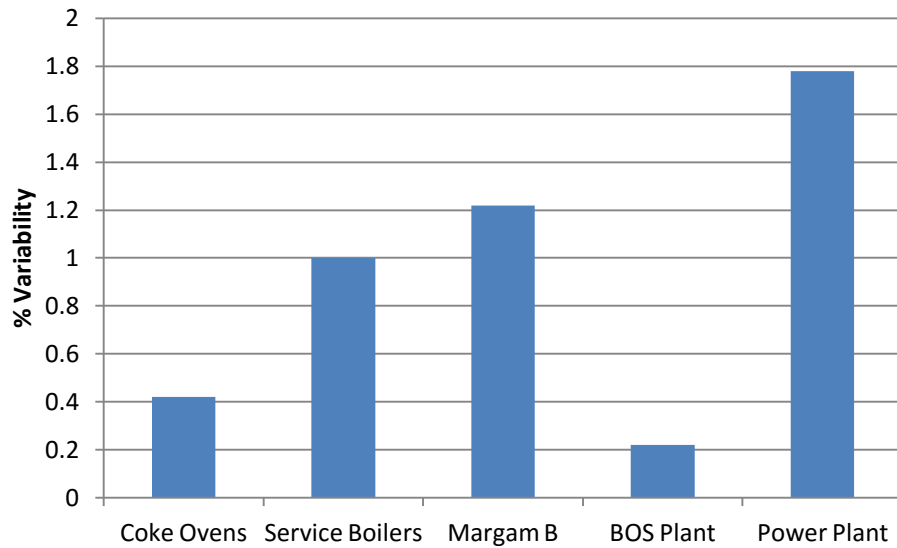

Figure 94 Variability of Plant Data

Relationships between flows and pressures were then determined which would help assess any data extracted from the PI archive. For example Figure 95 shows a direct relationship between export steam temperature and flow rate for the Service Boilers. If however, a data point outside the relation was identified then checks needed to be undertaken to understand why.

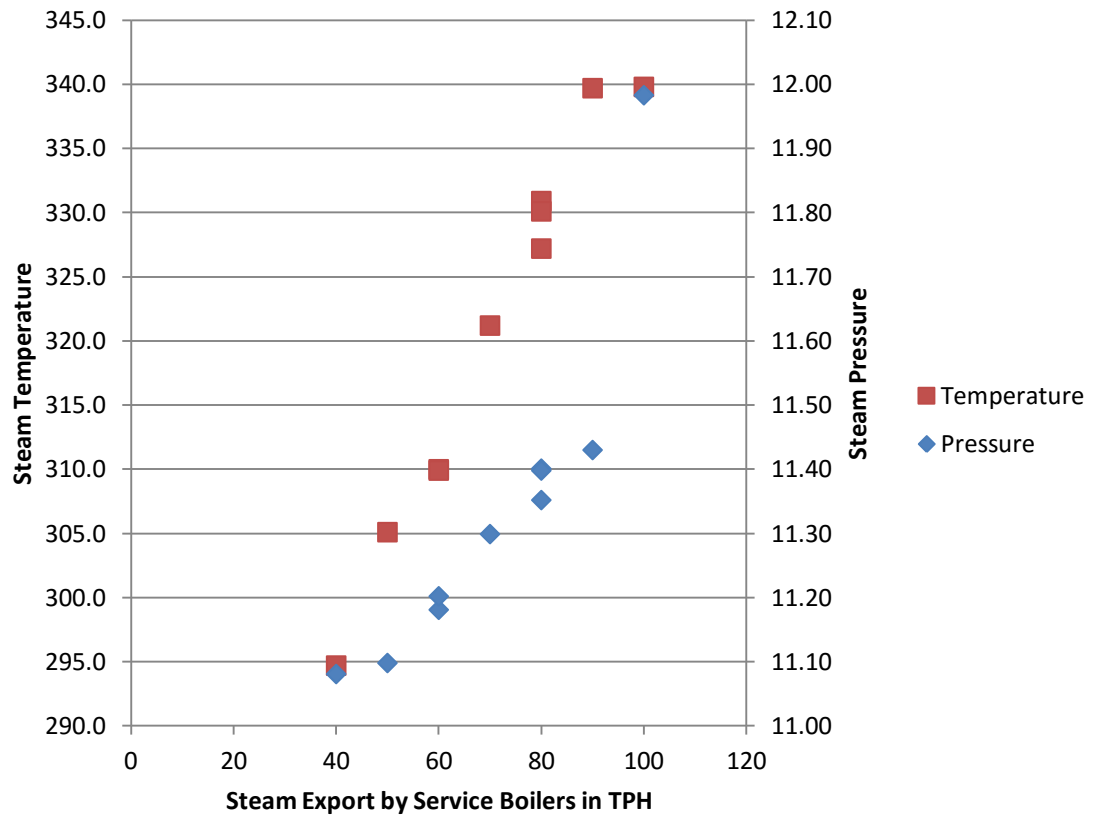

Figure 95: Example of data analysis for steam system

5.5.1 Improving the model

The model was then run, step by step, through 12 development phases as shown in Figure 96. The figure shows that each phase of the model was taken through the ten scenarios listed in Table 11. Between each phase of the model inputs were changed and the alterations are listed in Table 12.

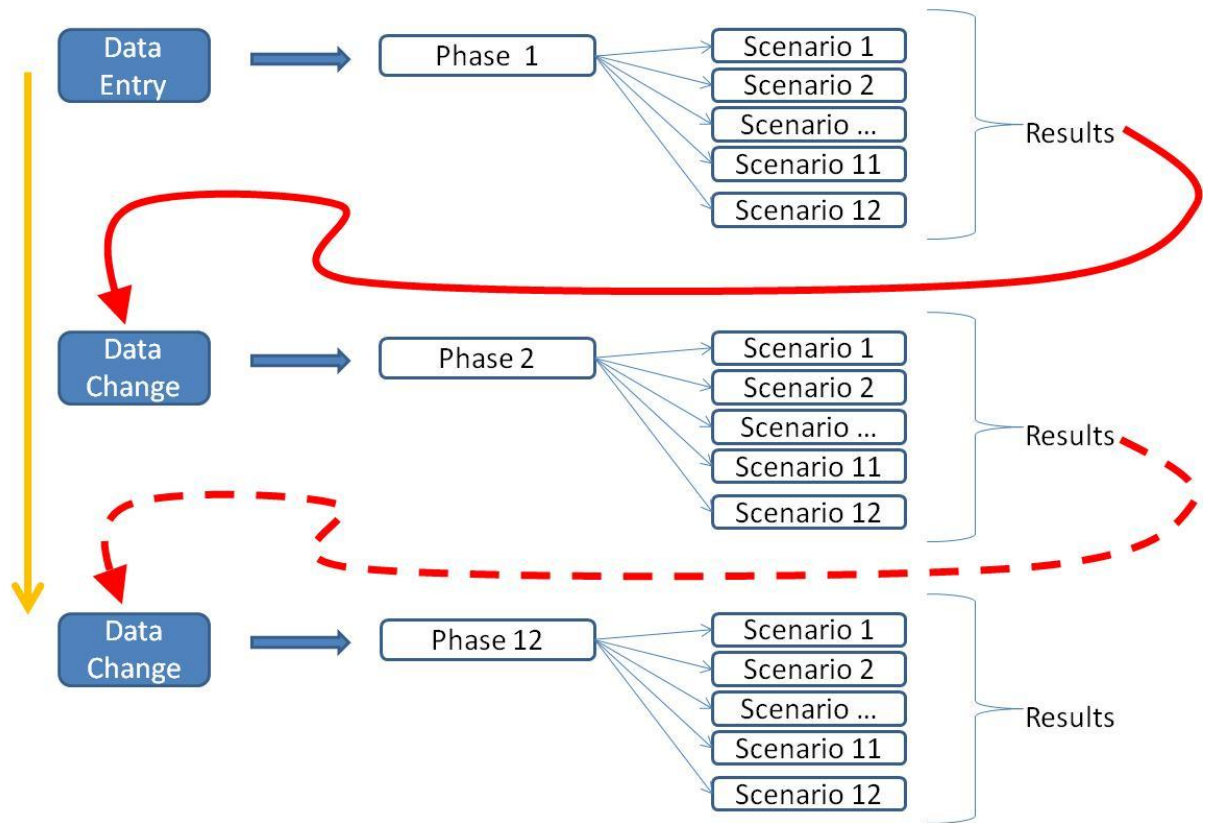

Figure 96 Development Sequence of the model

For example, when ‘Phase 1’ of the model was run and compared to plant data, as shown in Table 12, the model had a pressure error of 13.8% and a temperature error of 14.2%. The accuracy percentages listed in Table 12 are the maximum percentages over the ten scenarios for that phase. The percentage accuracy is defined as the difference between the modelled result and the actual plant data. Phase 2 was then developed by altering the pipe work configuration around the Service Boilers. The percentage accuracy then improved to 11.86% for pressure but remains at 14.26% for temperature.

As mentioned earlier some areas were difficult to dimension because of access difficulties. These were the main areas for further investigation during this developmental stage of the model. Table 12 summarises the various phases and also details of the various changes made to the physical inputs to the model. As can be seen the majority of the error was down

to the dimensional inaccuracies in hidden areas of plant, or simply errors in understanding pipe work layout.

Table 12 : Development Phases of the Model

Phase	Description of change to the model	Pressure	Temperature
		Model Accuracy	Model Accuracy
		%	%
1	Drawn as per drawings and sketches available	13.85	14.26
2	Surveyed the pipework and modified model pipework around the Service boilers	11.86	14.26
3	Surveyed the pipework around the BOS plant area and modified the model	6.16	14.26
4	Insulation survey - model adjusted to suit	6.16	10.05
5	Pipework around Grange Cross resurveyed and corrected	6.32	10.05
6	Surveyed more areas of plant and corrected model around the power plant	6.32	10.05
7	Surveyed more areas of plant and corrected the model around the hot mill area	4.05	10.05
8	Modified model around hot mill/cold mill connections	4.05	10.05
9	Modified model around the Power Plant area	3.89	10.05
10	Insulation survey - model adjusted to suit	3.89	13.61
11	Insulation survey - model adjusted to suit	3.89	14.65
12	Further insulation surveys - model adjusted to suit	2.77	4.10

Figure 97 then shows how the pressure errors for each area of the works developed during the phases 1-12 of the model. The figure demonstrates the step changes as a result of the pipe work improvements detailed in Table 12. In general the changes associated with each phase improved the models accuracy but as shown in Figure 97 the latter phase, phase 12, decreased the accuracy for Margam B, the Power plant and the Coke Ovens. Table 12 shows that phase 12 of the model entailed alterations to insulation data. The hypothesis was that the insulation data changes resulted in changes to the physical properties of the steam thus effecting the pressure calculations.

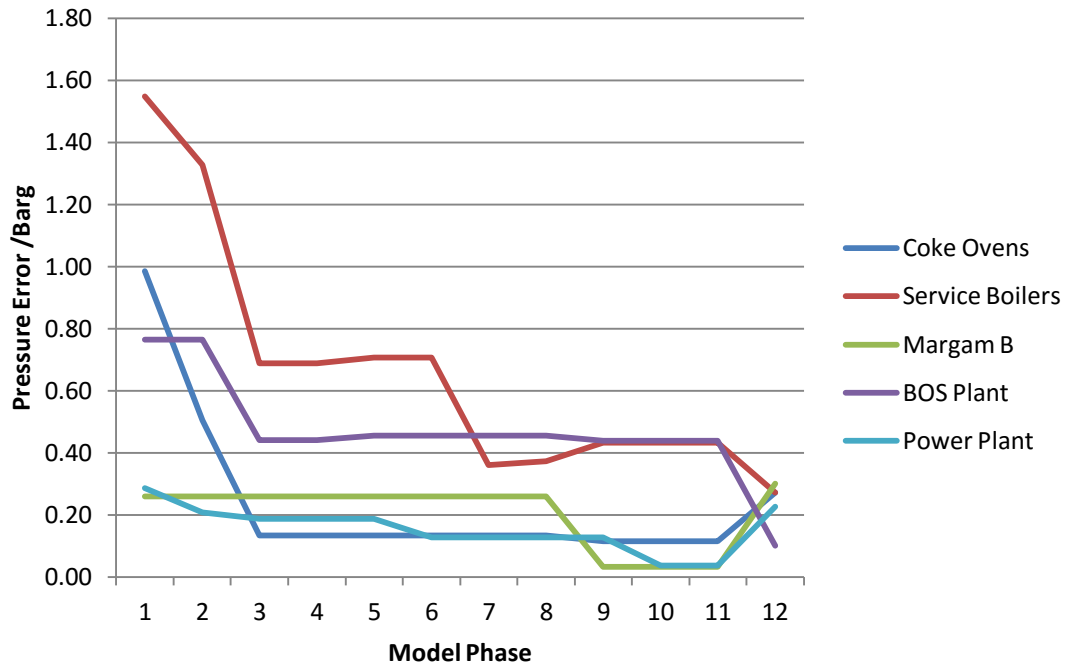

Figure 97 Pressure Errors by model Phase

Figure 98 shows a similar plot for the steam temperature error between the modelled results and the actual plant data. The figure shows that as the model was developed through its phases so the temperature error improved or worsened by the changes detailed in Table 12. It was clear to see that the initial focus was on the pipe work configuration and pressure accuracy then the insulation and temperature error was improved. The worsening error for Phases 10 and 11 relate to insulation data changes made in various sections of the works that has increased the average temperature error over the ten scenarios for each phase. The final insulation data changes, as part of phase 12, have reduced the maximum temperature error to just 10 °C over the ten scenarios.

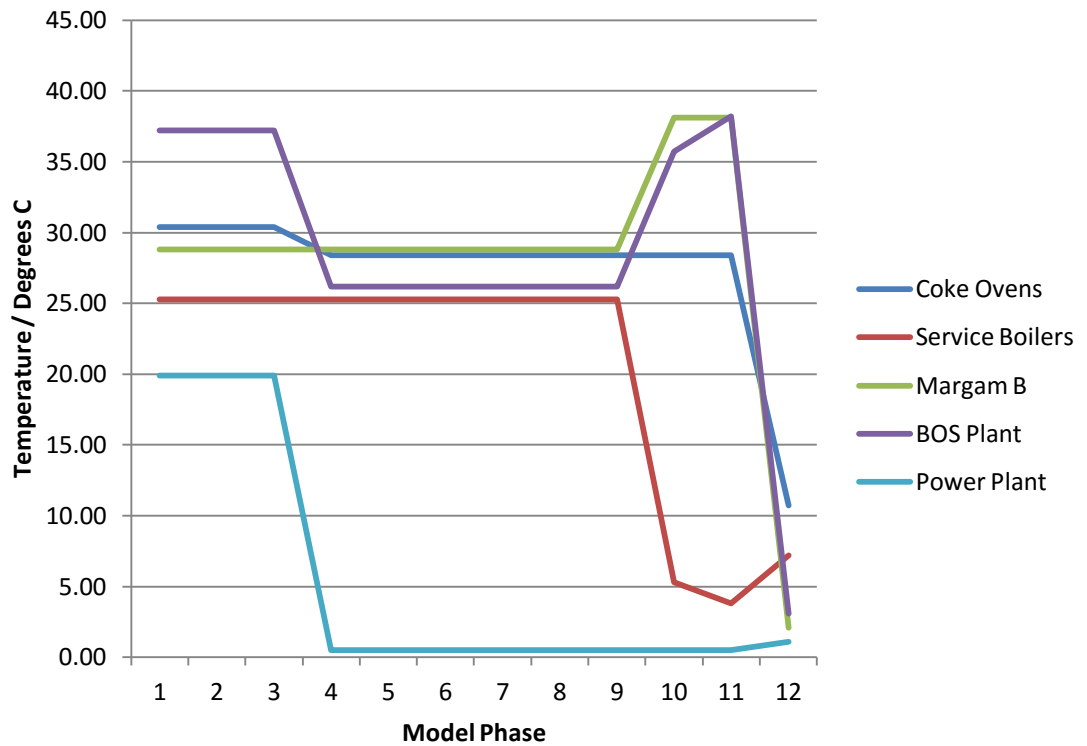

Figure 98: Temperature errors by Model Phase

Figure 99 plots both pressure and temperature error on the same graph and represented as % error. With a pressure percentage error improved from 13.85% down to 2.77% and a temperature percentage error reduced from 14.25% down to 4.1%.

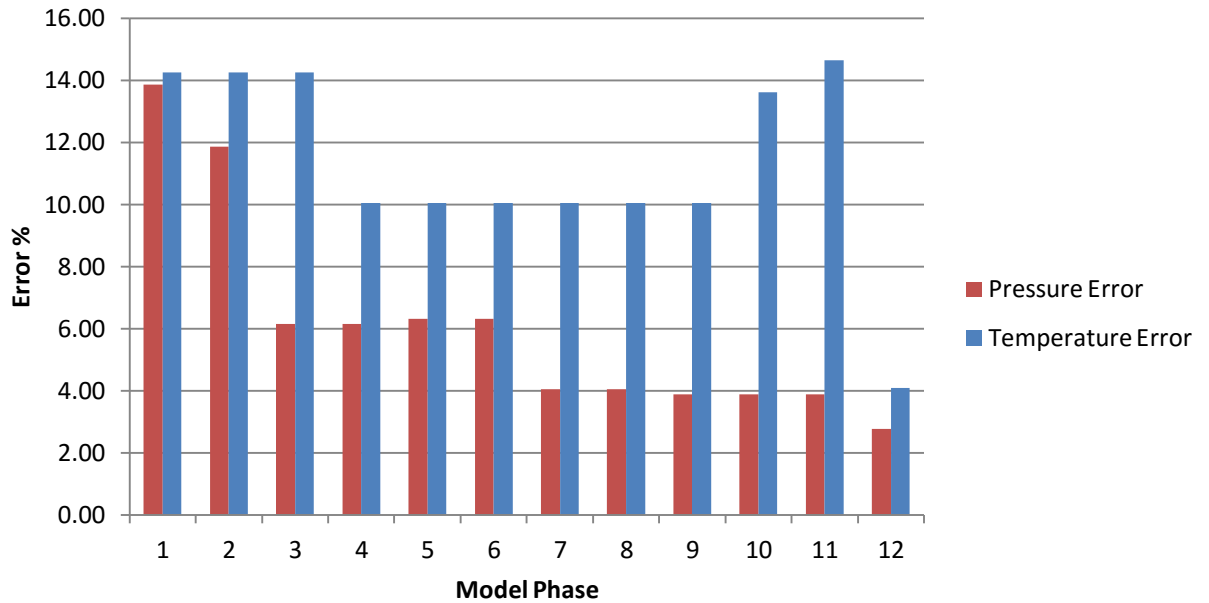

Figure 99 Development Phases of the Fluidflow Model

Figure 100 shows the extent of the maximum errors for the final phase of the model over the ten different scenarios. The figure shows that Scenario 1 has the least error and Scenario 7 has the highest error. Further analysis into the data reveals that the highest percentage error occurs in the Power Plant and Margam B areas of the works. Both these areas have multiple unmetered consumers and very complex pipe work arrangements resulting in this level of uncertainty in local flow level and pipe work configuration, hence a higher error. It was therefore recommended that when the model was to be used, it must be run through the ten scenarios in order to fully predict what the percentage error in the output would be and thus ensure as accurate a result as possible.

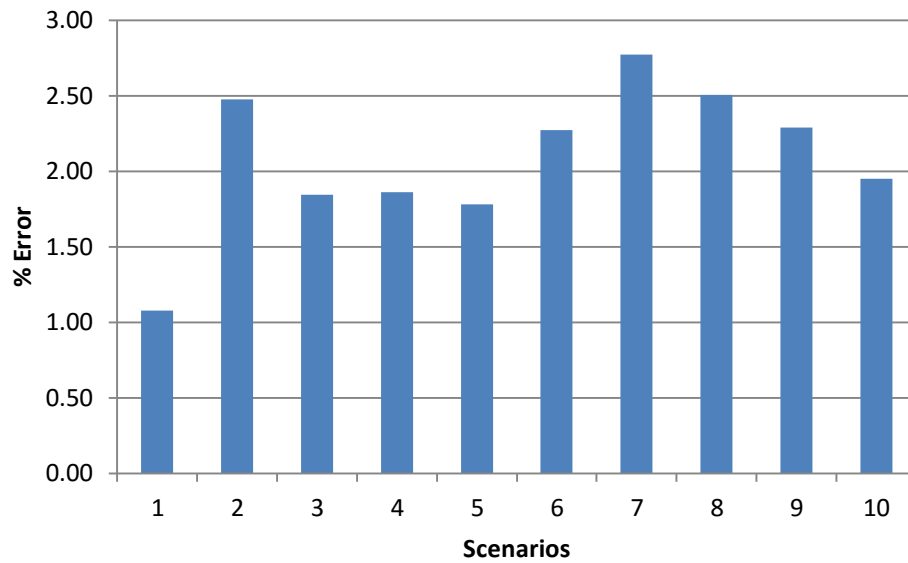

Figure 100: Percentage Error by Scenario

5.5.2 Sensitivity Analysis

To further understand the effects of any errors in physical dimensions to the overall accuracy of the model, when compared to plant data, the physical attributes shown within Table 13 were altered and the model was recalculated. Surface finish, internal diameters and bend radii were varied.

Table 13 : Parameters altered for Sensitivity analyses

Parameter settings	12	a	b	c	d	e	f	
Insulation	100mm	100mm	100mm	100mm	100mm	100mm	100mm	100mm
Pipe diameter	388	388	388	388	388	388	388	381
Surface Finish	0.05	0.05	0.05	0.05	0.05	0.2	0.1	0.05
Radius	4	2	3	6	5	4	4	4

Figure 101 shows the cumulative errors for the works area for the parameter changes shown in Table 13. The worst case, with a bend radius ratio of only 2, gives an error of 0.74%.

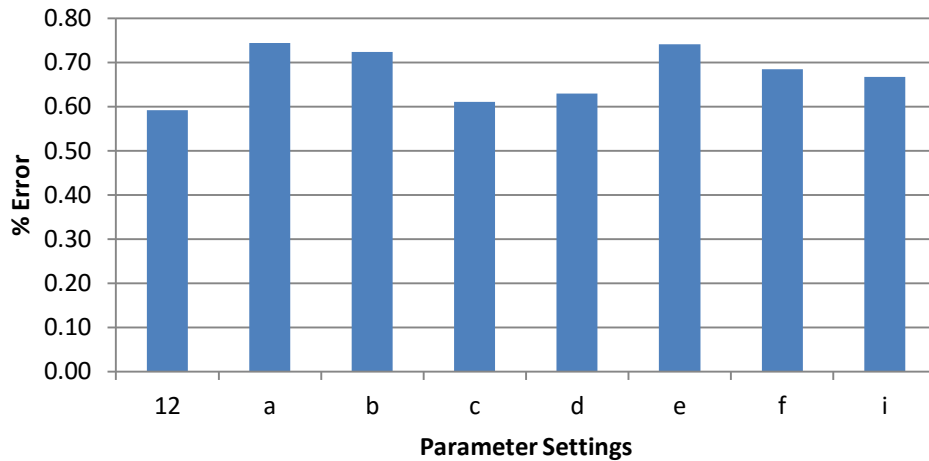

Figure 101 : Sensitivity Analysis

As previously discussed the plant data varies by up to 1.8% around the average. Therefore, with plant data varying by 1.8% about the average, and the model producing results within 2.77%, of the average, it is therefore possible to conclude that the model was sufficiently robust to use for simulation purposes. The Model has therefore been built and developed through twelve phases, each being compared against data from ten scenarios of differing plant configuration. The model was then subjected to a sensitivity analyses to further understand how prone the model was to dimensional errors or inaccuracies in terms of pressure and temperature. This process produced a model that is within 2.77% error for pressure measurement and 4.1% error for temperature. Dimensional inaccuracies could then enable a 0.73 % error in pressure. This analysis was based on plant data that typically varied by 1.8% for each differing scenario of plant configuration. It is therefore concluded that the model is of reasonable accuracy, when compared to plant data, and suitable for use in simulating the 11 barg steam distribution system. The model can be defined as an essential tool for determining the optimum end use for further WHR studies and be used to simulate the various WHR boilers previously identified in Chapter 3 section.

5.6 Summary

A validated Model of the CSSW has been developed in Fluidflow3. In order to gain confidence, the software was first evaluated and compared against manual calculations. The model was then built and compared against actual plant data for ten scenarios of differing plant configuration. A sensitivity analyses was conducted of various parameters to aid the understanding of any possible deviation and error from dimensional inaccuracies. The study has therefore developed a model of the 11bar steam distribution circuit that replicates the real system to a reasonable degree of accuracy. This model can therefore be used to develop and improve the steam system and also to simulate the addition of WHR boilers at the CSSW.

The work presented in Chapter 5 describes the building of the model that is necessary to completes Aim 4 (ie a model to understand the impact of WHR on the CSSW). The Chapter describes the building and verification of a fluid model to predict the effects on Pressure and temperature of the CSSW steam systems. The chosen software package 'Fuidflow3' is described and an exercise is defined to gain confidence in its results by comparing the software calculated results to those calculated manually. This exercise is deemed successful and so a model is created of the 26km of pipe work that make up the CSSW steam distribution system. The model is then verified through a series of development phases as it is compared and verified against actual plant data for a number of defined operating scenarios. The final phase of the model produces results within 5 % of actual plant data and therefore considered accurate enough to replicate the actual steam distribution system. A sensitivity exercise is also described and conducted on the verified model to help ascertain its susceptibility to dimensional errors. The next Chapter describes

the use of the verified model to simulate the addition of WHR boilers to the CSSW steam distribution system.

6 Results and Discussion

6.1 Introduction

Chapter 3 defined the main UK industrial drivers for investments in WHR as the reduced reliance on electrical imports from the national grid, therefore isolating the case study works from the potential of industrial ‘blackouts’, as a result of the shortage of UK electrical generation. Chapter 4 described the steam system for the CSSW and the modelling of the steam system is described in Chapter 5. Thus, with a validated model of the CSSW 11bar steam distribution circuit, this chapter discusses the use of the model to simulate the addition of various Waste Heat Recovery [WHR] boilers to the steam system. The model provides the ability to simulate an ‘end use’ for the recovered waste heat using 11 bar steam to generate electricity from a new Turbo-Alternator [TA]. Thus this chapter concerns the effects of adding the potential WHR options, identified in Chapter 3, to the model developed in Chapter 5.

Figure 102 shows the steelmaking process flow diagram and the commercially available WHR opportunities are highlighted in red. As defined in Chapter 3, the other areas do not yet have commercially viable options for high grade WHR for the CSSW. The priority in terms of potential impact to the business is :-

- 1) Basic Oxygen Steelmaking [BOS] plant,
- 2) Continuous Annealing Processing Line [CAPL]
- 3) The Sinter plant
- 4) The Hot Strip Mill [HSM].

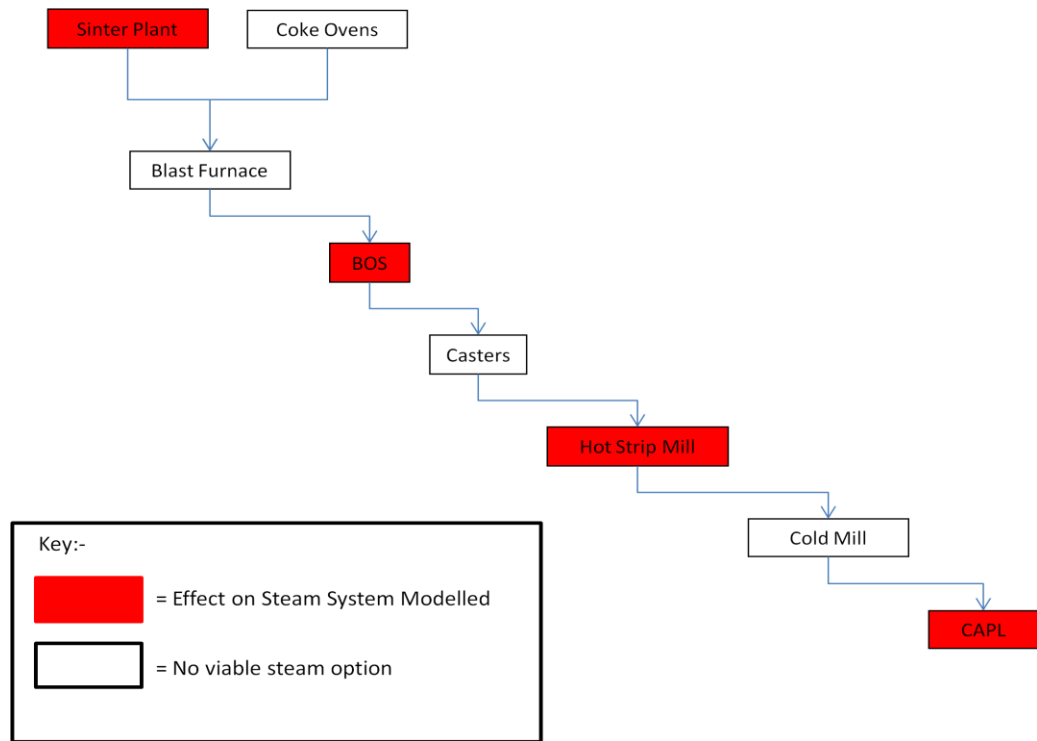

Figure 102: Steelmaking Process and WHR potential works areas

Figure 103 shows a schematic of the steam system and identifies the relevant areas of the case study works. The two red arrows represent the inputs of steam from a) the Service Boilers [in the South end of the works] and b) the Power Plant [in the North end of the works]. The results of the modelling of the addition of the WHR boilers is presented and discussed in this Chapter. It was also decided to explore the removal of the Service Boilers, as identified in Figure 103, from the steam system to clearly understand the relationship between the Service Boiler output and the addition of the WHR boilers. The results of this study are discussed in section 6.5.

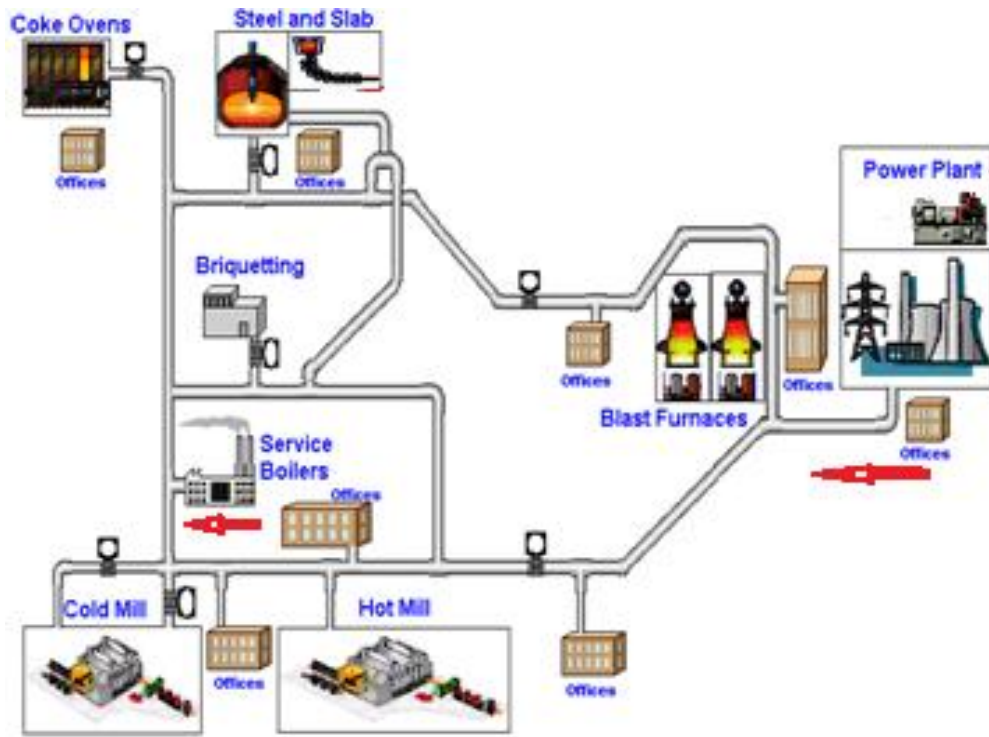

Figure 103: 11bar steam distribution system

6.2 Basic Oxygen Steelmaking [BOS] Plant

As discussed in Chapters 3 & 4 the CSSW had been exploring the essential replacement of the off-gas cooling system for the Basic Oxygen Steelmaking [BOS] plant. Figure 104 shows the Oschatz Evaporative cooling system that uses the heat in the off-gas to heat up and vaporise the water in steam drums. The hot waste gas from the converter [BOS Gas] is ducted through the off-gas system to cool the gas down before it is cleaned and made ready for storing in a gas holder.

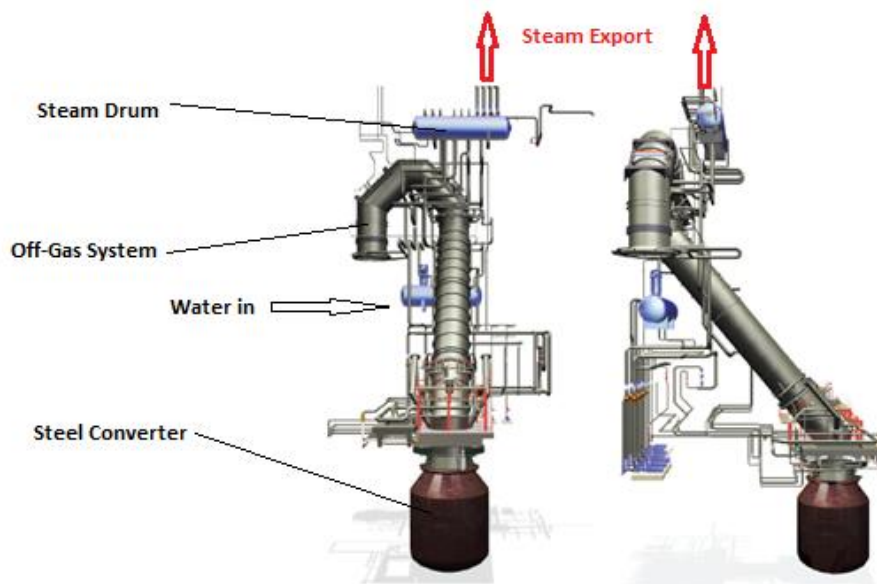

Figure 104: BOS Plant Evaporative Cooling system. Source(Kasalo 2010)

A typical energy content of 60MW_{TH} at $1700\text{ }^{\circ}\text{C}$ makes the waste gas stream very suitable for steam generation. The operation is a batch process and so steam accumulators are utilised to smooth out the steam export flow rate before it enters the steam distribution circuit. In Chapter 3 it was proposed that a Turbine Alternator [TA] should be installed to use the 11bar steam distribution circuit for electrical generation. Figure 105 schematically presents the export of steam from the BOS plant WHR boiler and the location of the new TA within the boundary of the existing power plant.

The BOS plant WHR steam boiler and the proposed TA were added to the model developed in Chapter 5 as new boundaries. Figure 105 shows the physical schematic of the model indicating the BOS steam import and the position of the TA. The location of the TA was a point of considerable deliberation by the case study works. Theoretically the turbine could have been located anywhere around the 11bar steam main so to ensure the turbine could be easily monitored and attended, it was decided to locate it behind the existing Power Plant thus ensuring maximum availability.

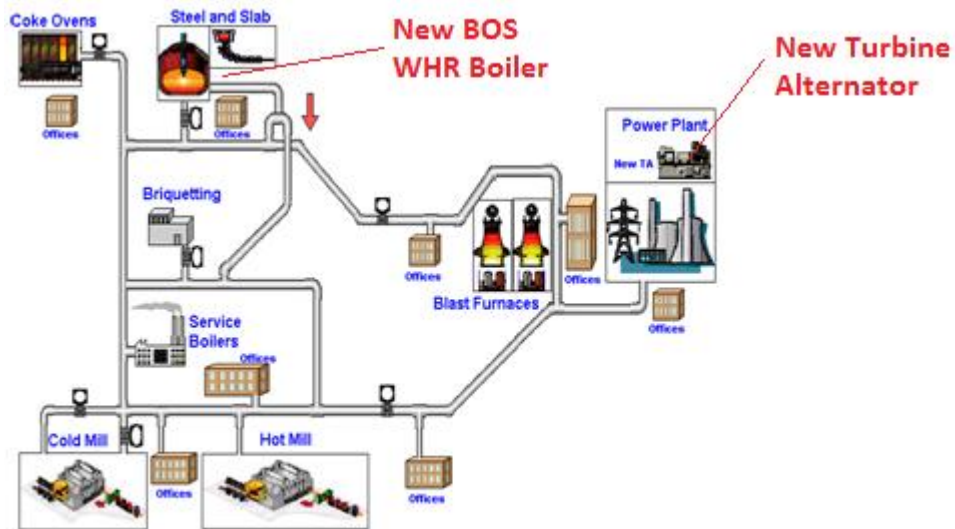

Figure 105: Schematic of the 11 barg steam distribution circuit

The requirement to add an interconnecting section of pipe work as shown in Figure 106 was identified. This interconnector would allow steam to pass from the North to the South end of the works even when sections of pipe are isolated for periodic maintenance. The works operates 24/7 365 days per year so continuity of supply is essential. Various sections of the steam mains are isolated throughout the year for essential maintenance. The steam system configuration enables whole year supply during these isolation periods. The new interconnector will enable steam to always travel from the BOS plant to the new TA thus ensuring maximum generation over the whole year.

Figure 106: shows the model and highlights the works areas and the interconnector. The figure also identifies two key consumers that have critical key steam requirements:-

- a) The Coke Ovens [min 9.4 barg @ 240°C]
- b) Margam B [minimum 11 barg @ 280°C]

The objective of the modelling was therefore to ensure that as WHR boilers are added these key parameters are maintained.

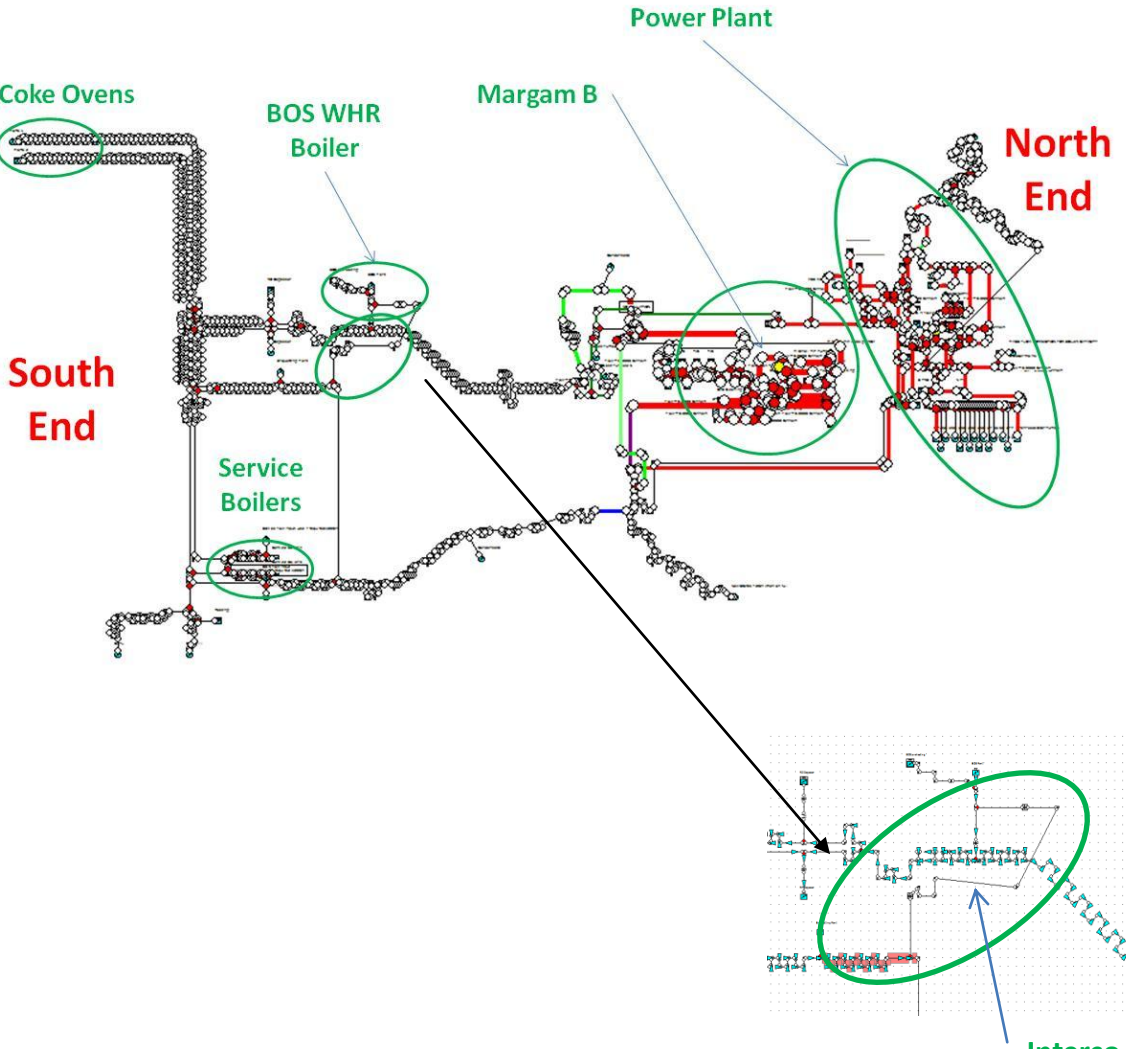

Figure 106: Fluidflow3 model of the 11barg steam distribution circuit

As described in Chapter 5, when using the model it is important that the ten mass balance scenarios were used to take the model through the mix of conditions experienced by the case study works Table 14 shows the scenarios with the addition of the steam export from the new BOS WHR boiler. The output of the WHR boiler is varied through the scenarios as recommended by the Energy Department of the CSSW.

Table 14: Scenarios utilised for modelling (all units in TPH)

<u>Scenarios</u>	1	2	3	4	5	6	7	8	9	10
Service Boilers	40	100	80	80	100	60	80	90	70	50
BOS Plant Export	40	40	40	30	30	40	0	20	20	30
Total Works Production	80	140	120	110	130	100	80	110	90	80
Total Power Plant Production	101	128	130	120	60	118	98	128	114	94
Coke Ovens	25	25	25	25	25	25	25	25	25	25
CRP	12	15	15	18	12	15	15	15	15	12
HSM	6	6	6	6	6	6	6	6	6	6
Briquetting	6	6	6	6	6	0	0	0	6	6
Degasers	0	20	0	0	20	20	0	20	20	0
BF	12	6	6	6	6	12	12	12	12	12
Losses	6	10	10	6	8	6	6	6	3	6
Heating	0	20	20	0	0	0	0	20	20	0
Total works Consumption	67	108	88	67	83	84	64	104	107	67
Total Power Plant Consumption	74	80	122	133	77	94	114	114	77	77
Total Produced	181	228	250	230	190	218	178	238	204	174
Total consumed	141	188	210	200	160	178	178	218	184	144

All Units in tonnes per hour (tph)

The model was configured and run through these scenarios and the results graphically presented in Figure 107. The pressure regulations documentation for the sites steam system stipulates a maximum system pressure as 13.5 barg. One of the main functions of the model was therefore to check that with the addition of any of the WHR options the system pressure will not exceed 13.5barg. As shown in Figure 107, Scenario 2 indicated a possible concern with pressures approaching the maximum of 13.5barg. The other scenarios were all shown to be sufficiently below 13.5barg and were not therefore considered to be of concern. Scenarios 5, 6 &10 have relatively low maximum pressures but still maintain a pressure at the Coke Ovens greater than the minimum specified as 9.4barg.

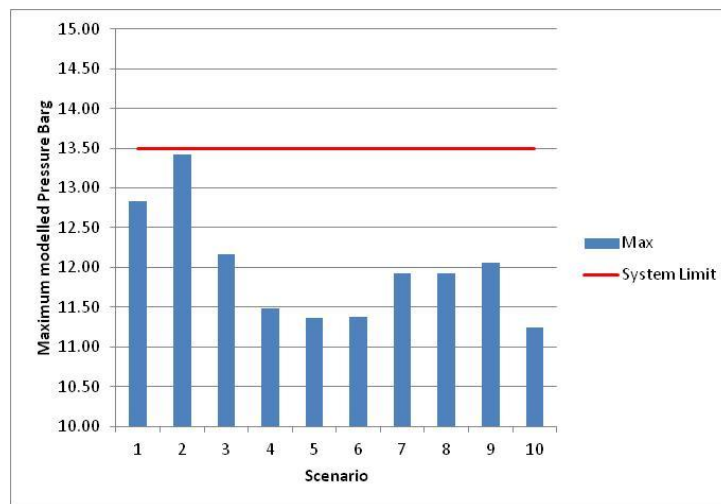

Figure 107: Predicted Maximum System Pressures

Figure 108 shows the calculated pressures for all the elemental components of the model when configured for Scenario 2. The node numbers, on the x axis, relate to the various elements of the model for example pipes, elbows and tees. The nodes approaching 13.5bar all relate to pipe work sections close to the service boilers. Scenario 2 is configured as maximum outputs for both the Service Boilers and WHR boiler, but a reduced level of local steam consumption, thus increasing the localised pressures around the boiler connections.

The Service Boilers are under a flow control philosophy and will therefore inject steam at whatever pressure is required to achieve the required flow. A possible option for the future would thus be pressure control for the service boilers. This would maximise steam injection rate but automatically ensure the pressure does not get above 13.5bar. As the figure shows the pressures for Scenario 2 range from 10.6 barg up to the maximum 13.5barg. The node numbers on the x-axis relate to positions around the model. By cross referencing node numbers with the model it is possible to deduce that the nodes at pressures as low as 10.6bar are some of the extremities of the pipe work system and not of concern. Whereas the areas approaching 13.5barg are in the proximity of the Service Boilers.

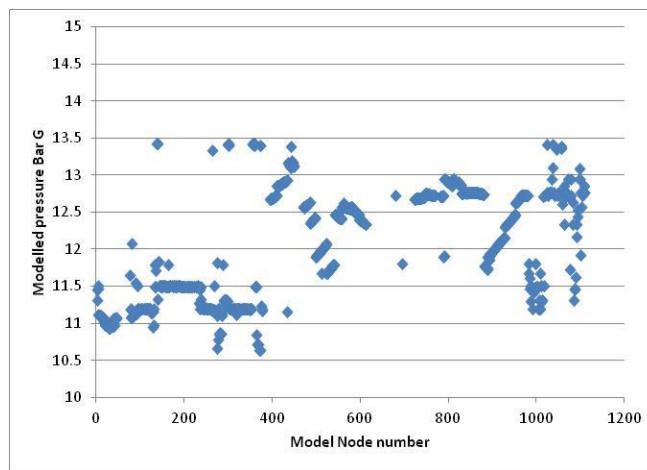

Figure 108: Predicted Pressures for individual model nodes

To show the effect of adding the BOS WHR boiler to the original model Figure 109 was plotted and it shows the pressure gain by adding the BOS plant WHR boiler and the new TA. The figure shows that the pressure has increased by up to 1.55 bar at the Coke Ovens, 1.5 bar at the BOS plant area and 1.39 bar at the Service Boilers. This is logical as more steam is being fed into the south end of the works and so it would be expected that the pressure increased. The pressure is pushing the steam from the south end of the works to

the north end where it then exits the system through the new TA which is in pressure control and hence is controlled around 11.2bar.

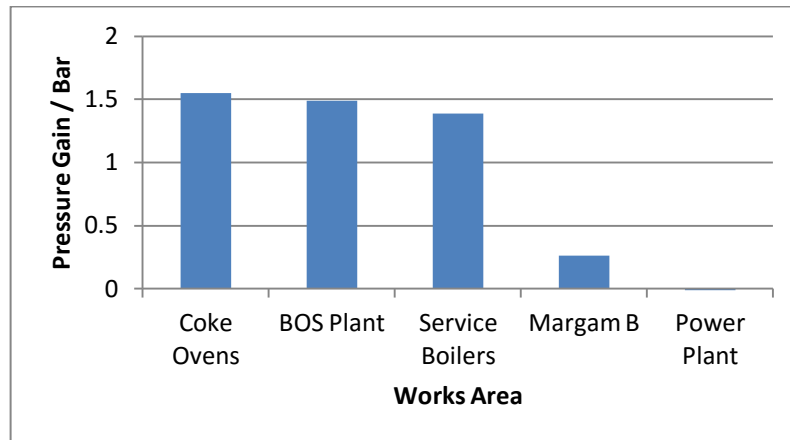

Figure 109: Predicted Pressure Gain by Works Area

The temperature gain plot, Figure 110 shows a slightly different picture. By adding the BOS WHR boiler and the new TA the temperature has increased slightly for the BOS area as would be expected, due to local high temperature steam injection, but has decreased at the Coke Ovens and 'Margam B'. Any significant decrease in temperature is of concern if the steam is utilised as superheated steam for turbines for example. As shown in Figure 110 the temperature drops are of only 15OC and therefore are not considered significant although it is considered pertinent to critique the results further for the two areas shown ie a) Margam B and b) the Coke Ovens.

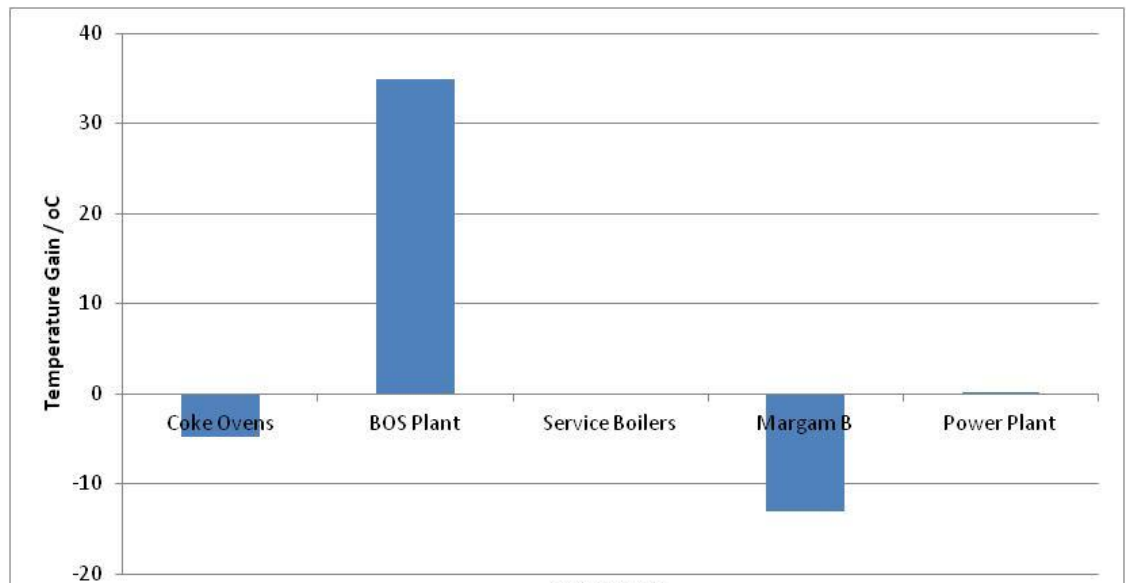

Figure 110 Predicted Temperature Gain by Works Area

These two areas are therefore investigated further:-

a) Margam B

After studying the results for the individual scenarios it was identified that Scenario 9 was the potential issue and produced the lowest predicted temperature at Margam B. Further analysis of the scenarios themselves shows the importance of the North to South mass flow balance. As stated in Chapter 5 the balance of the steam flow, from South to North, or North to South, is dependant on the mass balance at the South end of the works. A negative mass balance at the South results in steam export to the North End. The South End mass balances modelled result in the South End steam export rates as shown in Figure 111. As can be seen the scenarios represent a split of export and import of steam to the south end. For example scenario 2 shows an import of 40tph to the South end.

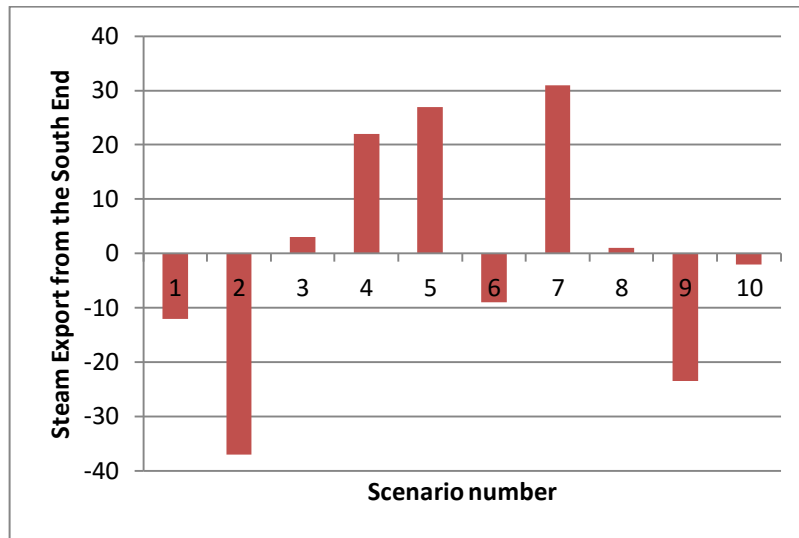

Figure 111 Steam Export from the South End of the works

Figure 112 shows the effect of adding the steam from the BOS WHR boiler and for the majority of scenarios the South End exports steam. Scenario 9, due to low boiler outputs, shows the South End reverts back to importing steam.

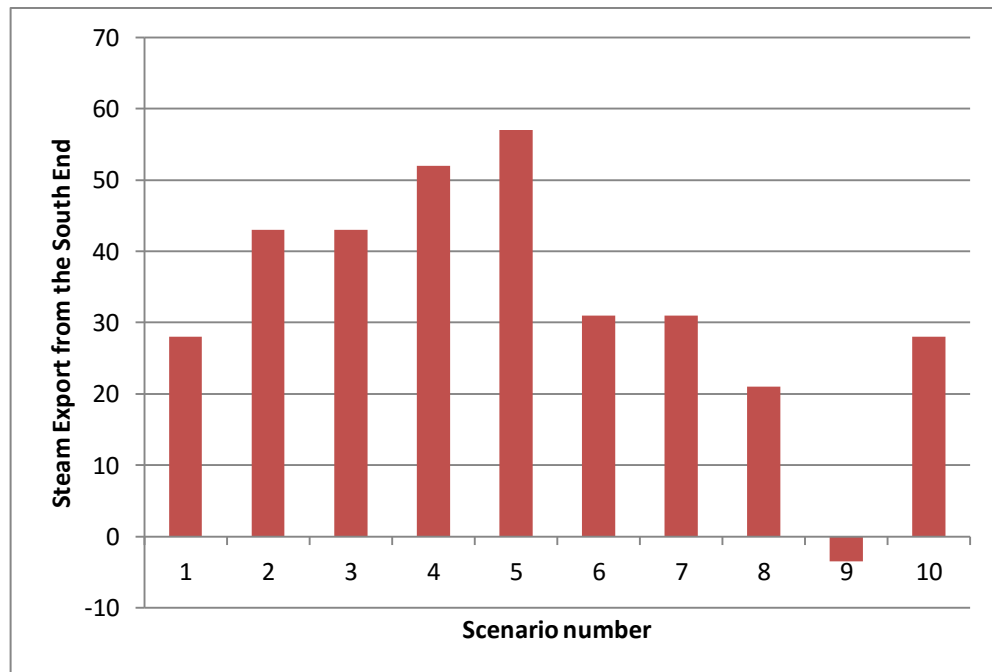

Figure 112 Steam Export from the South End of the Works including BOS WHR boiler

Scenario 9, with a small export from south to north, present a third condition as shown by analysis of the predicted results and portrayed in Figure 113. If the South End of the works has an equal mass balance i.e. steam consumption equals the steam supplied by the service boilers and BOS Plant, then a condition exists where there is no flow, or virtually no flow, from one end to the other. Figure 113 portrays the balance as a weighing scale to pictorially explain the ‘balance’ that can occur in the system. The model shows that under this condition a slug of steam if formed around a mid-point along the pipe work and is alarmed as a ‘low flow’ condition by the model. The position of this mid-point depends on the relative pressures of the South and North Ends. The mid-point can feasibly move from North to South as consumers and generators are varied slightly.

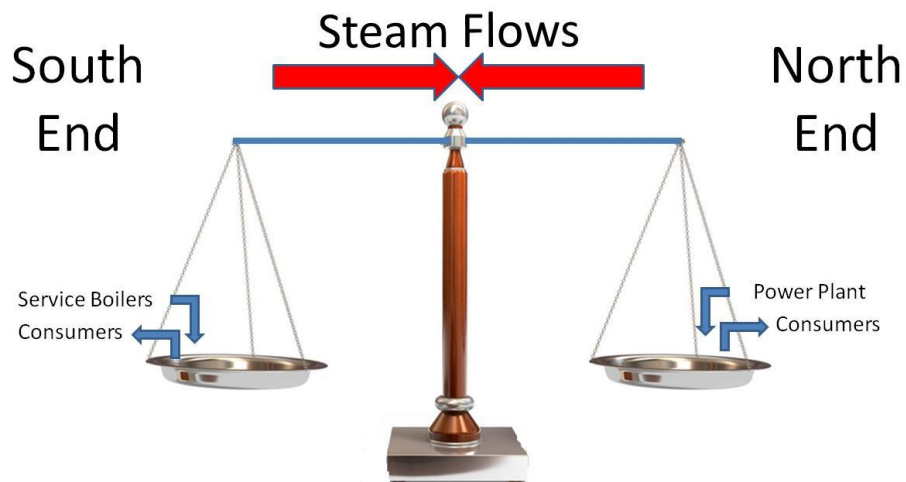

Figure 113 Representation of the balance of the steam system

This slug of steam would slowly cool and condense out through the steam traps. Data from the recently installed steam meters, as shown in Figure 114, concurred with this modelled phenomenon. It was possible to plot mass flow and temperature showing that under certain conditions it is possible to have zero flow at the midpoint. The data showed that the zero

flow can last for a number of days and result in the temperature of the steam slug drops to just above the saturated temperatures of 188°C. This results in possible cold spots and the potential for steam to condense in the pipeline as small pockets of water. These pockets can then be picked up and accelerated, by the steam, and can damage the pipeline. This effect is called ‘water hammer’ and should be avoided. Stopping the steam from condensing or fitting more steam traps to remove the water would illuminate the possibility of pipe failures so careful management will be essential.

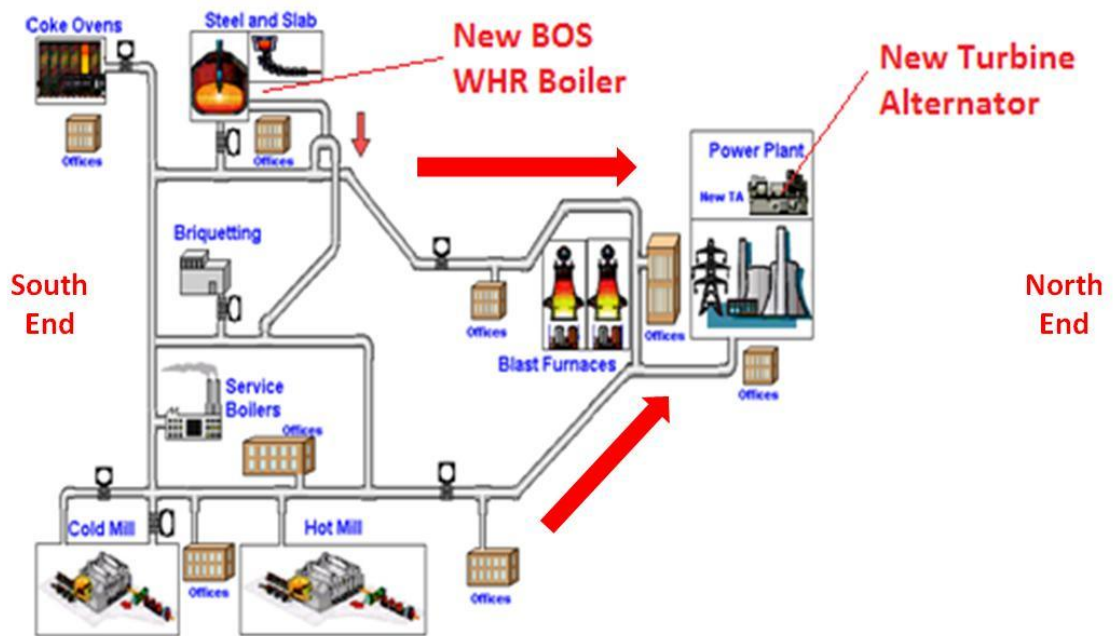

Figure 114 Schematic showing zero flow condition

The mid-point zero flow, as shown in Figure 114 would be a concern to the case study works because of the risk of water hammer and thus the Service boiler outputs would have to be altered to ensure that there is a total mass flow from South to North or North to South dependent on the plants configuration. This is done manually at the case study work’s Energy Control Centre. Comparing Figure 111 and Figure 112 it’s possible to see that by

adding the BOS steam to the SE results in a greater average flow from S to N. Thus reducing the risk of ‘no flow’ conditions and any possible complications associated with water hammer etc.

The model therefore shows that the low temperature of the steam to Margam B is due to the small export from the South End that then travels over 1.25km before reaching Margam B thus dropping 12 °C in temperature.

b) Coke Ovens

Figure 115 shows that the low temperature at the Coke Ovens occurs during scenario 10. As shown the temperatures are typically greater than 270°C but for scenario 10 the temperature drops to 245°C.

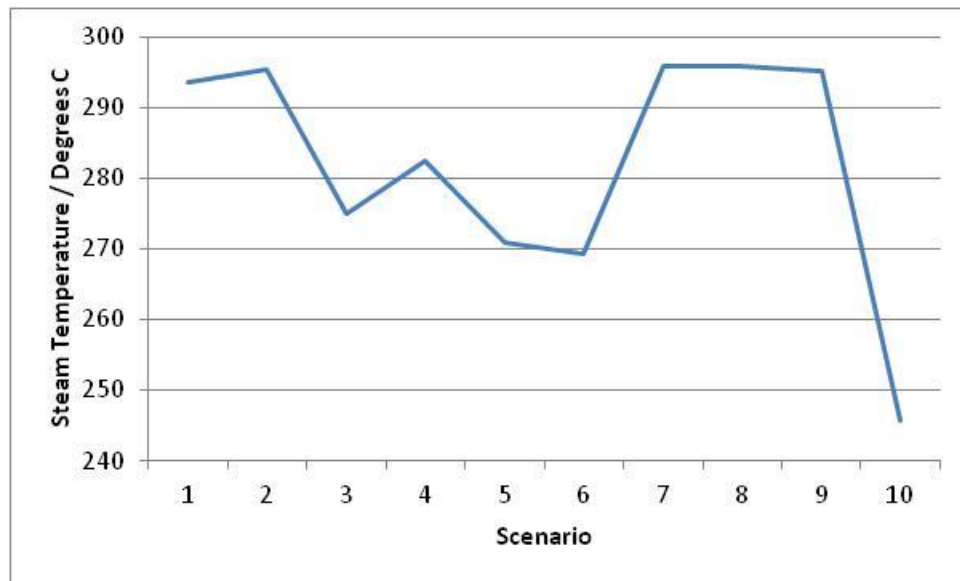

Figure 115 Steam Temperature per Scenario

Referring back to Figure 112 Scenario 10 is very similar to scenario 1, in terms of the fact that the south end is exporting 28tph of steam, but the predicted temperatures shown in Figure 115 are very different. To understand this, the model itself had to be studied and it

shows that the low temperature at the Coke Ovens was due to local flow directions around the South West corner of the steam system. Figure 116 shows that with the Degasser on, the BOS Plant export on a relatively low flow, results in the majority of the higher temperature steam from the BOS plant to be used in the degasser thus causing the Coke Ovens to be fed with steam from the Service Boilers. The service boilers are on a relatively low output and therefore the steam temperature is reduced as stated in Chapter 5.

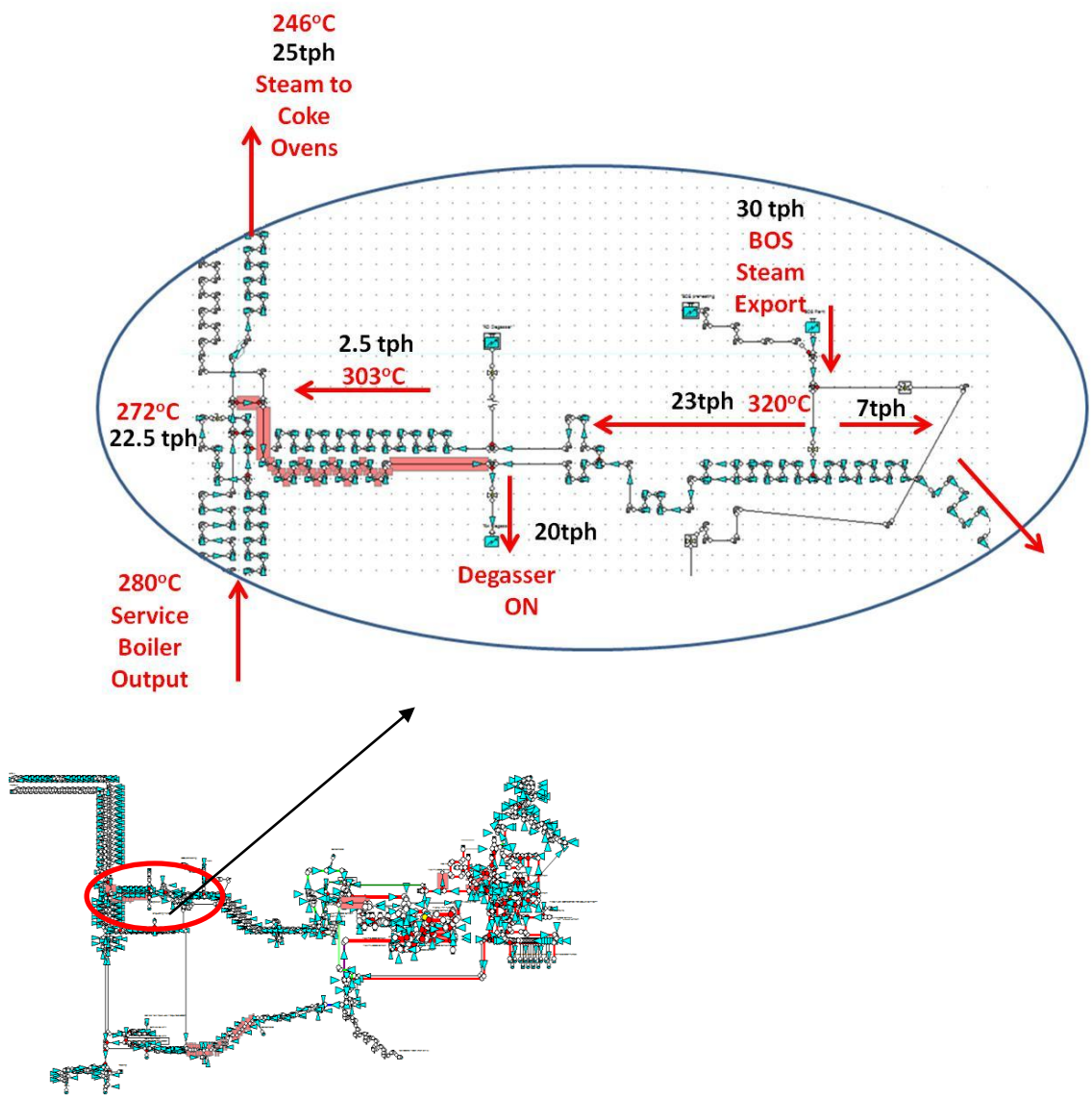

Figure 116 Modelling of the South West Corner of the steam system

This investigation has therefore demonstrated that the lower temperature calculated at the Coke Ovens for scenario 10 was due to the local flow directions in the South West Corner of the works. As defined, the Coke Ovens has a minimum temperature requirement of 232°C so a temperature of 245°C is potentially of concern. It is already understood that Service Boiler Temperatures are proportional to Service Boiler output so this low temperature can be overcome by increasing the Service Boiler outputs as shown in Figure 117. The figure demonstrates that as the Service Boiler outputs are increased so does the Coke Ovens steam temperature. The relationship is not quite linear and it's thought that this is due to the relative pressure increases and resultant directions of flow in the North West corner of the distribution circuit. This proves that by increasing Service Boiler outputs it is possible to maintain the steam temperatures required at the Coke Ovens.

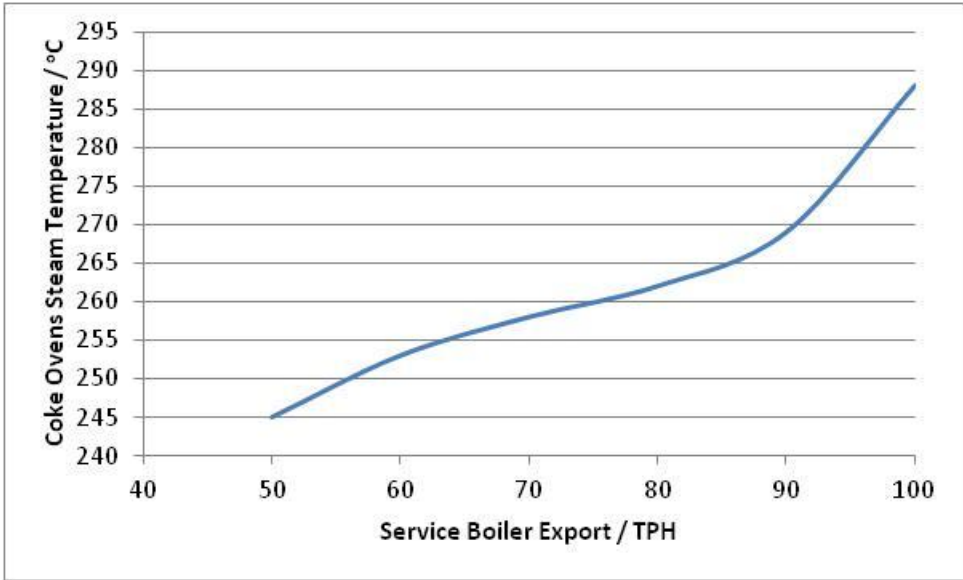

Figure 117 Scenario 10 Service Boiler export flow vs Coke Ovens steam temperature

Modelling has therefore confirmed that the steam distribution system is capable of accepting steam from the proposed BOS WHR boiler. The ten scenarios can be achieved

and successfully supply steam to the consumers without going into an over pressure condition or with too much of a temperature drop. Although the investigations have raised concerns raised about:-

- 1) Scenario 2 – the pressure approaches the maximum 13.5 bar so care must be taken when running the Service Boilers and the BOS WHR at maximum outputs
- 2) Scenario 9 – this scenario potentially produces a condition where no flow exists between the South and North Ends. This condition results in a slug cold steam sat in the midpoint of the distribution pipe work runs raising concerns over water hammer. Continuous monitoring of the flow meters and altering of the Service Boiler outputs to ensure that there is always flow from South to North becomes a necessity.
- 3) Scenario 10 – this scenario raised the issue of possible low temperatures at Coke Ovens. This can be overcome by increasing the output of the Service Boilers

Concluding that the steam system can accept the steam from the BOS WHR boiler, a business case was developed for the essential replacement of the Off-Gas system incorporating an upgrade to Evaporative Cooling totalling £53m. The procurement processes for the various installations was instigated in 2012 for a planned completion for early 2013.

The scale of the proposed developments are shown in Figure 118 to Figure 120. Figure 118 and Figure 118 show the top bend of the off-gas system indicating the scale of the project. The off-gas ductwork is over 4m in diameter and 30m high. Figure 119 shows the three accumulators which hold 7 tonnes of steam each and the super heater required to superheat the steam before export into the steam main. Figure 119 shows the new 19MWe TA

installed behind the existing power plant which includes 9 MWe of spare capacity for future WHR projects. Figure 120 shows an aerial schematic of the proposed layout showing the geographical setting of the boiler, accumulators and steam main tie ins. Figure 120 shows an Operators Screen, developed as part of this project, to monitor system pressures and record steam and electricity production. The scheme was completed in January 2013 and in the 23 months to December 2014, has saved over £8m in electrical import and has saved over 59,000 tonnes of CO₂.



Figure 118 Top Bend of the off-gas system.



Figure 119: Steam Accumulators, superheater and the new TA in Powerplant

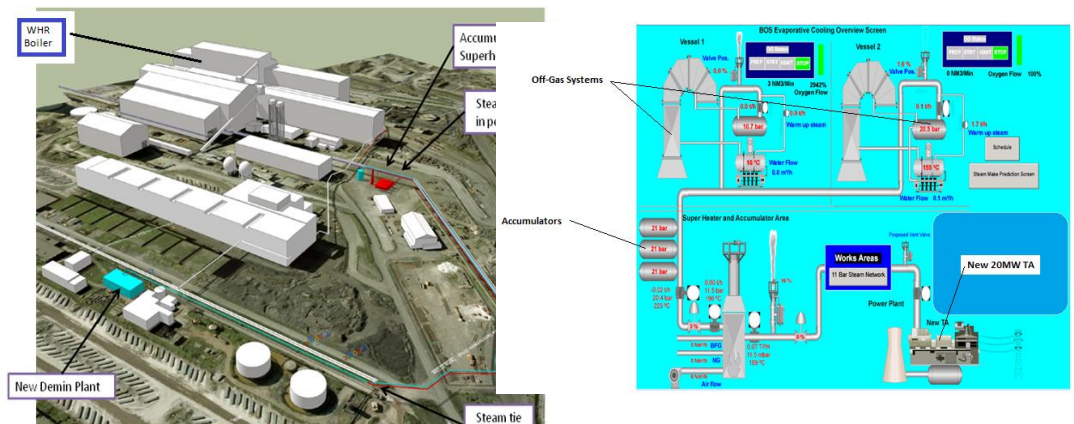

Figure 120: Positioning of new BOS Plant equipment and new mimic screen

Since the installation is not been possible to fully compare the results predicted in this modelling exercise because a number of the flow, pressure and temperature meters have malfunctioned. Ideally a whole re-verification process would be undertaken but due to inoperable meters it has not been possible to compare predicted and actual results.

However, it is possible to conclude that the model has successfully predicted the effect of the addition of the BOS WHR boiler to the steam system. By monitoring Service Boiler pressures and flows with various BOS WHR boiler outputs it was possible to see that for all scenarios the pressure has not exceeded 13.5 barg and the temperature at the consumers has been acceptable for satisfactory operation.

The meters are planned to be repaired and recalibrated in 2015 which is beyond the deadline for this project. It will therefore be a recommendation that the verification process is conducted once the meters are operable again.

6.3. Continuous Annealing Process Line [CAPL]

The model was modified to incorporate the layout shown in Figure 121. This enabled the assessment of installing a WHR boiler and piping the steam to both the CAPL and Cold

Mill. The model was run through the 10 mass balance scenarios shown in Table 11 with the addition of the 7tph from the proposed CAPL WHR boiler.

The WHR Boiler was added with an output to the existing CAPL steam system and an extra 500m length of pipe work was added to connect the existing CAPL and Cold Mill steam systems together as portrayed by Figure 121. Both the CAPL and Cold Mill steam systems are at 3.5barg and are supplied by pressure reducing 11barg steam. The CAPL WHR boiler will generate 3.5 bar steam and connect directly into the CAPL and Cold Mill steam systems via the new 500m length of pipe work. The CAPL process itself consumes 3tph, so with a WHR boiler output of 7tph, there would be an expected 4tph export from CAPL to the Cold Mill steam systems as shown in the figure. The Cold mill consumes between 9 and 15tph of steam. The model therefore simulates 7tph steam production, by the CAPL WHR boiler, with 3 tph being consumed locally and 4tph exported to the cold mill. From a mass balance perspective this concept reduced the 11barg steam demand of CAPL and Cold Mill.

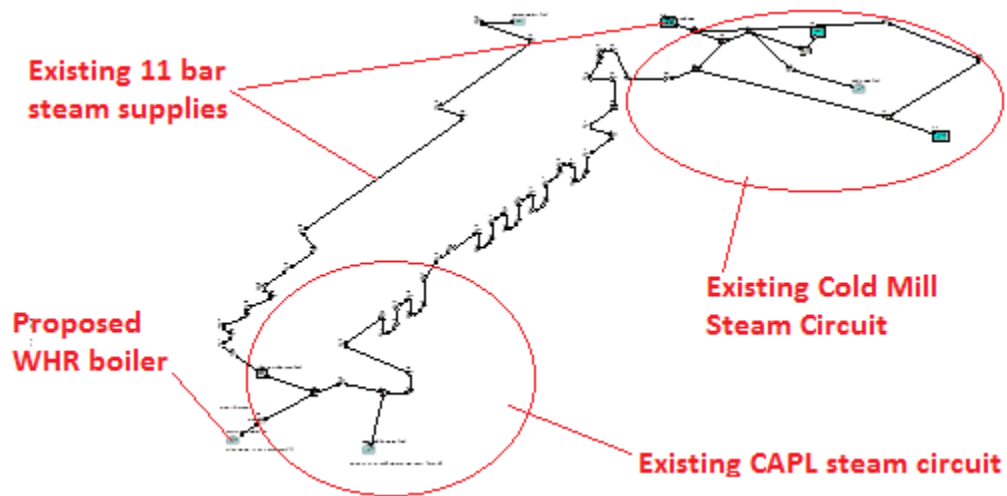

Figure 121: Fluidflow3 Model adaptations

With an output of only 7tph only a marginal effect on pressure was witnessed as shown in Figure 122. Interestingly the maximum pressure gain is seen for scenario 8 and not for scenario 2, which has the maximum Service Boiler and BOS WHR boiler outputs.

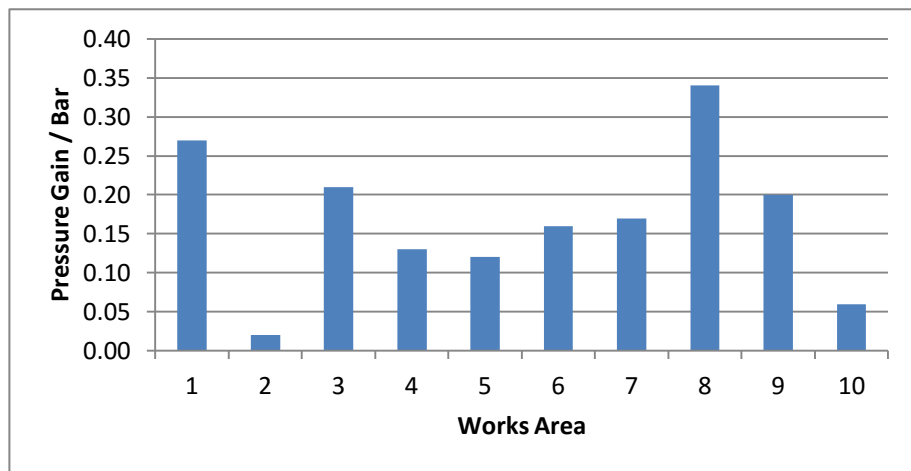

Figure 122 Pressure Gain from adding the CAPL WHR Boiler

As shown in Figure 123, for scenario 8 the maximum pressure gain is seen at the works areas at the south end of the works. Installing the CAPL WHR boiler could therefore

increase the South End pressures by 0.3bar but as shown in figure 6.7 the pressure is 12.2 barg is well below the limit of 13.5 barg.

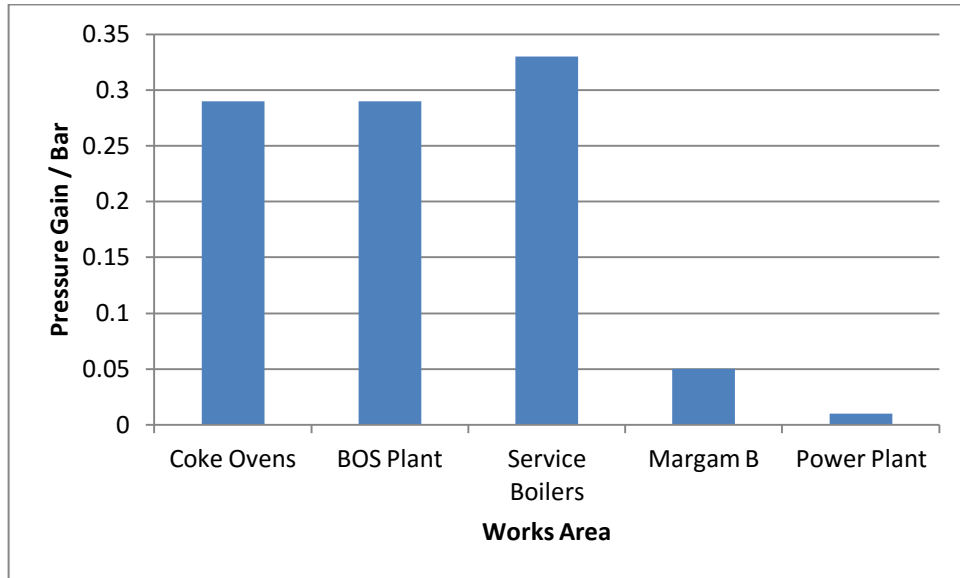

Figure 123 Pressure gain by works area by adding the CAPL WHR Boiler

Scenario 2 though does see a slight increase in pressure and as shown in Figure 124 taking the pressure closer to the 13.5bar maximum limit.

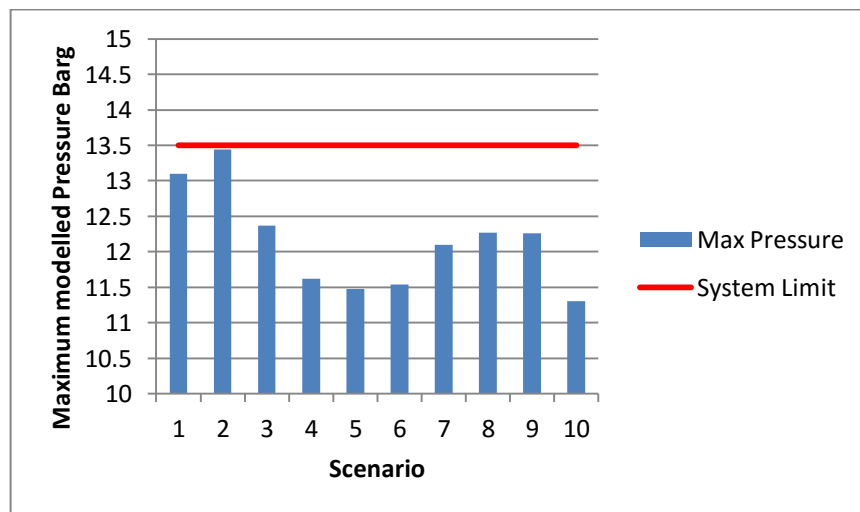

Figure 124 Modelled maximum system pressures by adding the CAPL WHR boiler

As far as the temperature effect is concerned, as shown in Figure 125, increased steam temperatures are seen at the Coke Ovens and a decreased temperature is seen at the BOS plant. The predicted steam flow directions were studied to understand this condition. Further analyses of the model data revealed that the pressure at the South East corner of the works, where the CAPL is located, is increased and this pushes mass flow of steam up the eastern pipe work resulting in the Coke Ovens being supplied with more steam from the BOS plant rather than the Service Boilers.

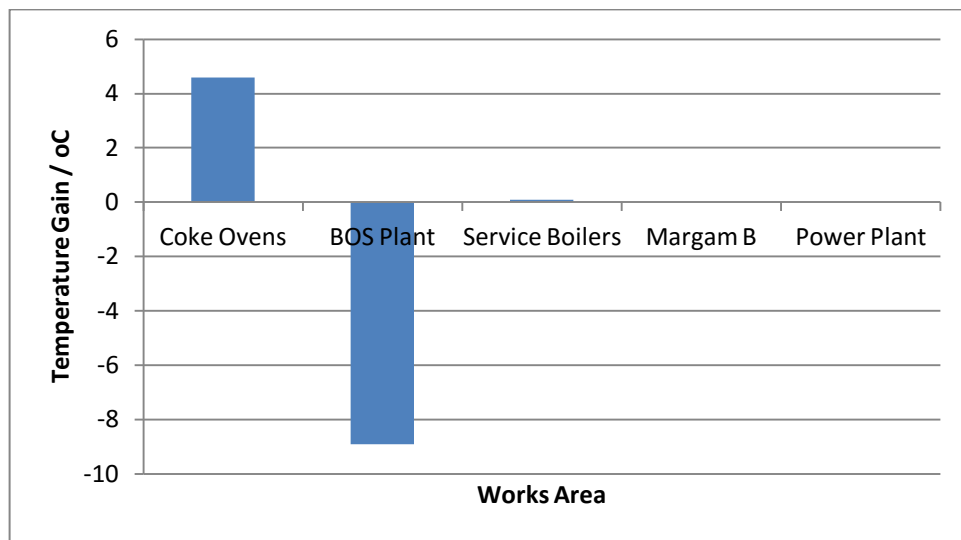

Figure 125 Predicted temperature effect of adding the CAPL WHR boiler

These temperature differences are only small and therefore have little impact on the consumers.

It is predicted that the addition of the CAPL WHR boiler to the steam system that already incorporates the BOS WHR boiler, would have little impact on pressures and temperatures.

It should be noted though that if the Service Boilers and BOS WHR boilers were on maximum outputs, i.e. scenario 2, then adding the CAPL WHR boiler will push the system pressures closer to the maximum of 13.5 bar.

From a local mass balance perspective, Figure 126 shows how the CAPL WHR boiler would in effect reduce the 11bar steam demand from the 11 barg steam system by the CAPL and Cold Mill. The maximum demand is shown to drop from 15tph to 10tph in the winter period.

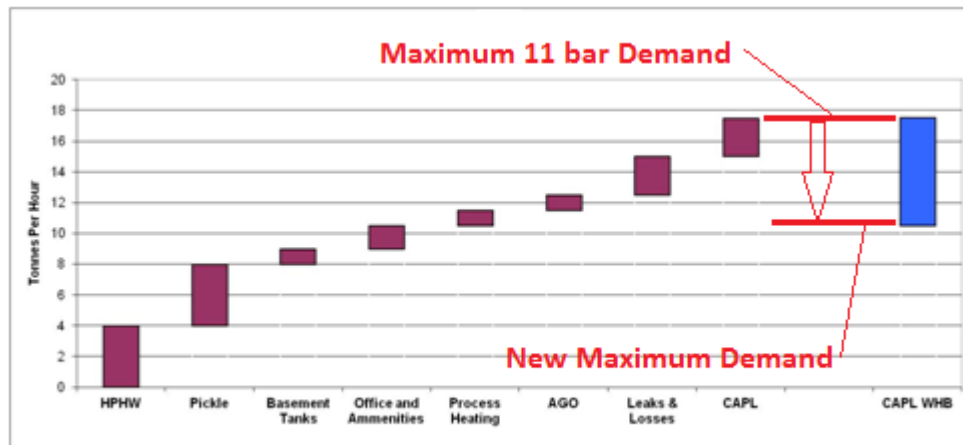

Figure 126 Local effect on the Mass balance by adding the CAPL WHR boiler

With an 'end use' of between 8 and 15tph and a potential generation of up to 10tph, as shown in Figure 126, the project is to incorporate a vent to surplus any excess steam to atmosphere. During the winter months the vent will be zero but during the summer the vent could be 2tph at times. Further work should be conducted once the boiler is installed to look to utilise this waste energy for bay or office heating to further reduce natural gas and electrical consumption. This concept therefore makes 7 tph of 11 bar steam available for the new TA with a resultant electrical generation of 0.9MW or £500,000 per year savings by reducing electrical import. A business case was then developed and the funding approved in 2011 for installation in 2013. Unfortunately due to limited availability of the CAPL line and contractual issues with the chosen supplier the WHRB had not yet been fully commissioned.

6.4. Sinter Plant

As defined in Chapter 3 section 6, the installation of a WHR boiler on the Sinter Plant cooler has the potential to generate 30tph of steam. To predict the effect of this additional steam input to the North End of the steam distribution circuit the model was again modified.

As shown in Figure 127, the required additions were made to the main 11 bar steam model to incorporate a steam run from the area of the Sinter Cooler to the nearest connection point behind the Blast Furnaces. The Model was run through the series of scenarios, identified in Table 11, simulating various works and WHR boiler outputs

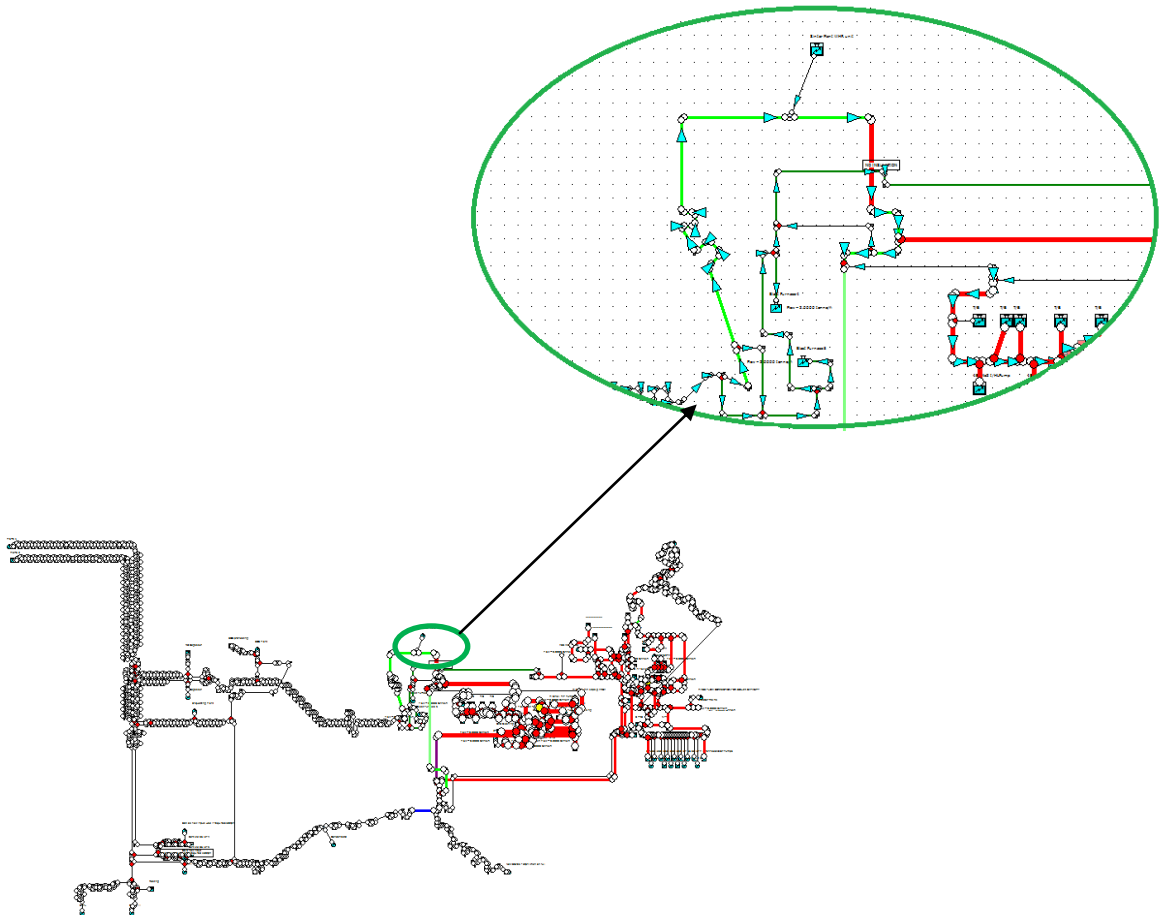

Figure 127: Zoom in on the North East Corner of the Model

The predicted results are presented in Figure 128, as can be seen scenario 2 causes the system pressures to exceed the 13.5barg maximum. All other scenarios produce pressures below the maximum but Scenario 2 which is maximum volume of Service Boiler and BOS plant results in a system pressure of up to 13.76 barg

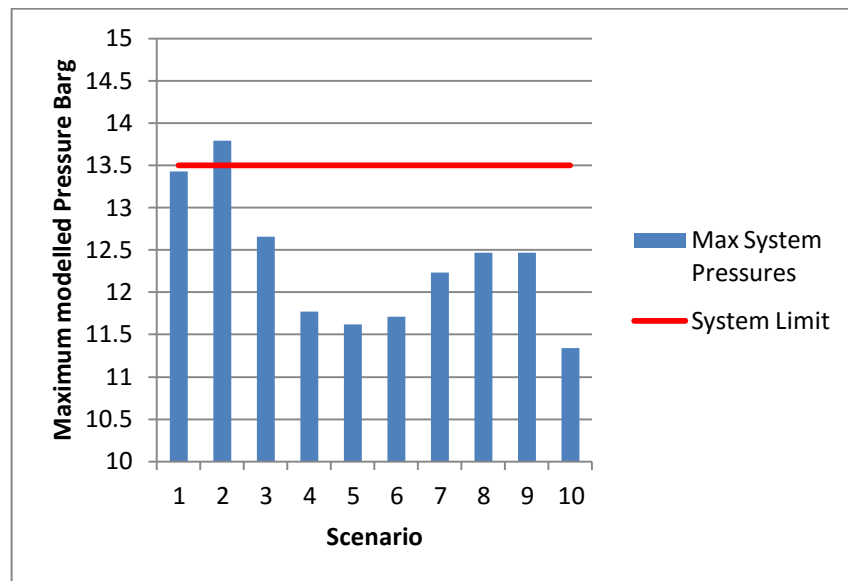

Figure 128: Predicted Maximum Pressure per Scenario

Figure 129 shows that the predicted pressure gain is across all areas and therefore of particular concern. This would not be acceptable and so if WHR was to be employed to all three areas further steps would have to be taken to reduce system pressures

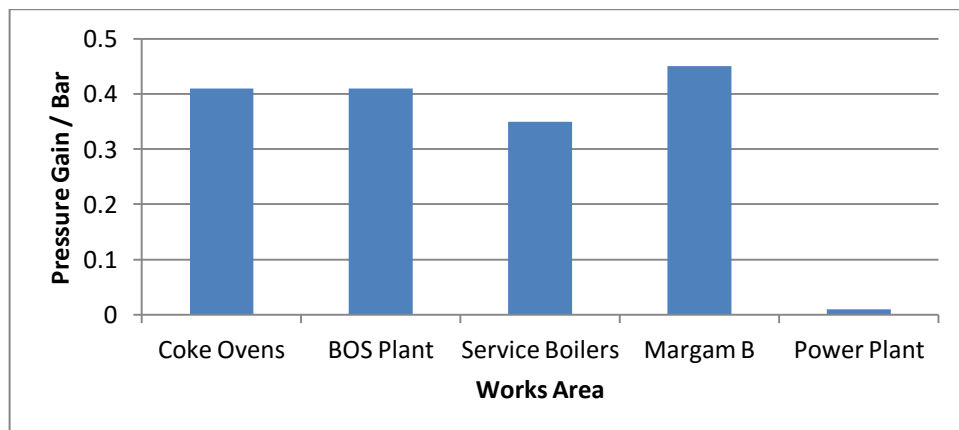

Figure 129 Pressure Gain by Works Area

Figure 130 shows the effect on the distribution system pressure by reducing the Service Boiler outputs for Scenario 2. It has been predicted that the Service Boiler outputs would need to be dropped from 100tph to 80tph to bring the system pressure down to around 13bar which, with no safety margin, could still be considered too high and it is more likely that the Service Boiler outputs should be limited to around 50tph to reduce the system pressure to 12 Barg.

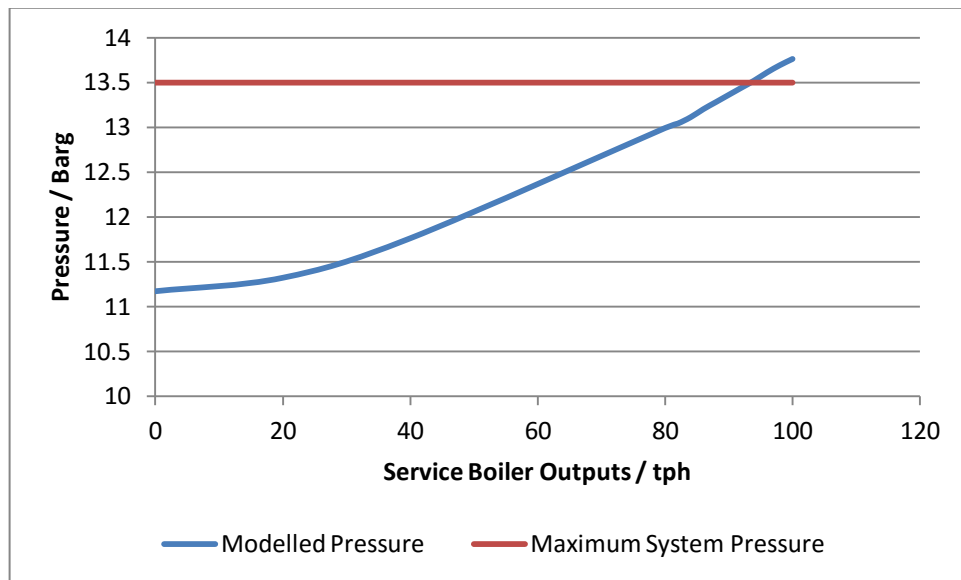

Figure 130: The relationship between distribution system pressures and Service Boiler outputs for Scenario 2

The analysis has shown that it is not possible for the steam distribution system to accept WHR boilers from the BOS plant, the CAPL and the Sinter Plant. The results show though that the Service Boiler Outputs would have to be limited to 50tph to reduce the system pressure.

Figure 130 also shows that the Service Boilers could be turned off completely if all three WHR boilers were running. The study shows that without the Service Boilers the steam temperature and pressure would be sufficient for effective operation for all consumers. The

Service Boilers would have to remain as an essential standby for when the WHR boilers are down for maintenance.

With the Service Boilers off-line, the works steam is supplied from Waste Heat rather than from indigenous gas boilers. This gas could then be released for further electrical generation in the new power plant that the case study works is exploring (Tata, 2013).

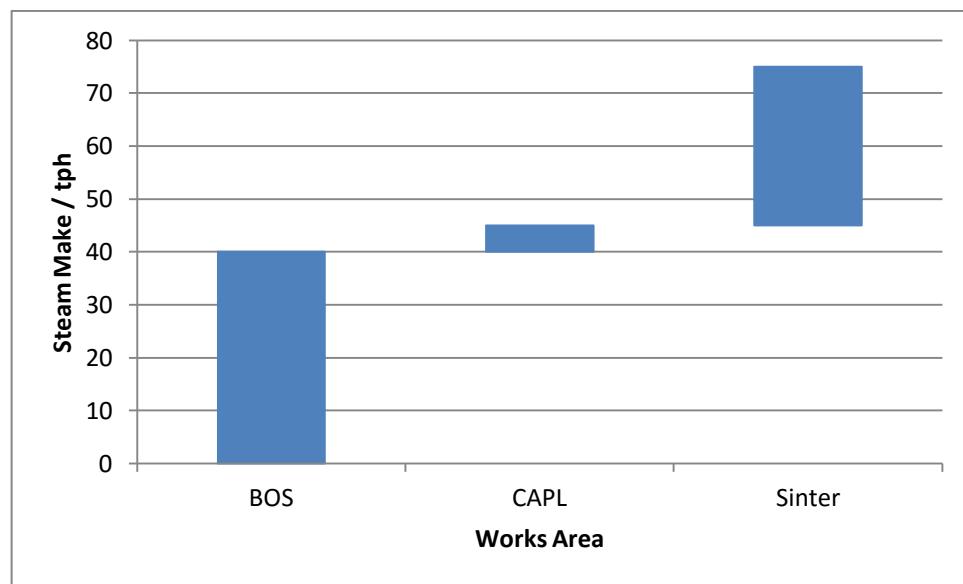

Figure 131 Steam Generation from WHR Boilers

With the Service Boilers out of service the South End then changes back to an importer of steam as shown in Figure 132.

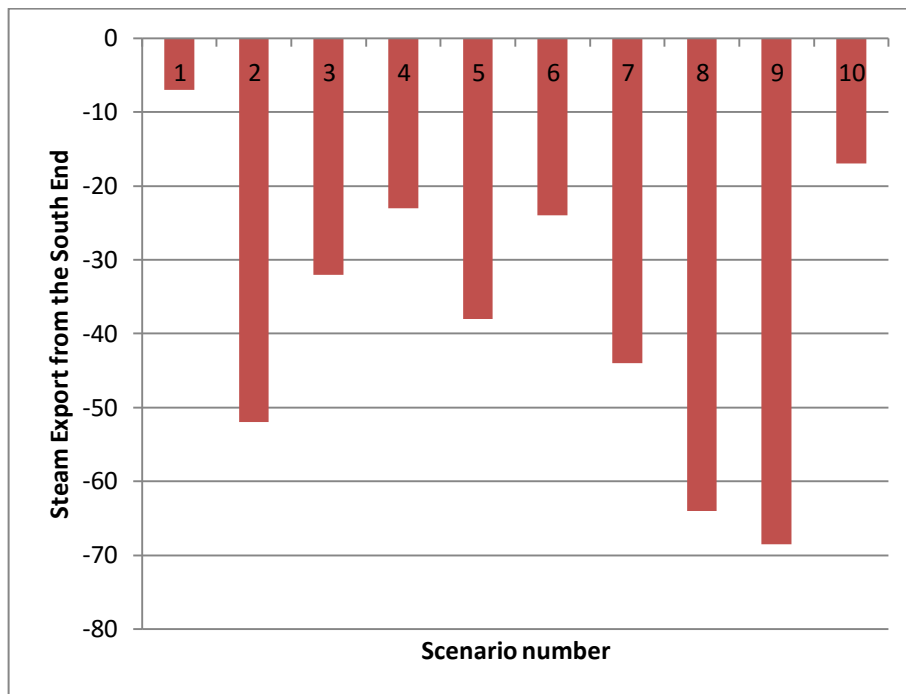

Figure 132: Steam Import to South End when Service Boilers Off

When scenario 9 is considered, with all three WHR boilers in operation but the Service Boilers off-line it is predicted that sufficient pressure and temperature for the Coke Ovens to operate are available. As soon as the BOS WHR boiler is turned off though the pressure and temperature is insufficient. Leading to the conclusion that the South End of the works can be supplied purely by WHR boilers as long as there is a hot standby Service Boiler arrangement, that automatically starts, when the system pressure drops below say 11.5barg.

6.5. Hot Strip Mill [HSM]

As discussed in Chapter 3 section 6. A WHR option practiced at other steel works and referenced within the BREF notes (EC 2001) is Evaporative Cooling of the furnace skids. This would entail the complete replacement of the existing cooling system and hence capital intensive, require weeks of furnace outage and thus only likely to be done as part of

an essential replacement project. The case study works has been exploring the installation of an additional furnace and so incorporation of an evaporative skid cooling system would be worth considering. This section therefore explores the possible steam generation from an evaporative skid cooling system should one of the furnaces need essential replacement. The case study works advised that a furnace would produce approximately 15tph of steam. The main 11 barg model was modified to accept the steam output from the proposed evaporative cooling system. The 10 scenarios were then studied but with the Service Boilers output reduced to 40 tph as highlighted in section 6.3.

Figure 133 shows the predicted results of the scenarios. The figure shows that the pressures are consistently below 12barg and are therefore considered acceptable.

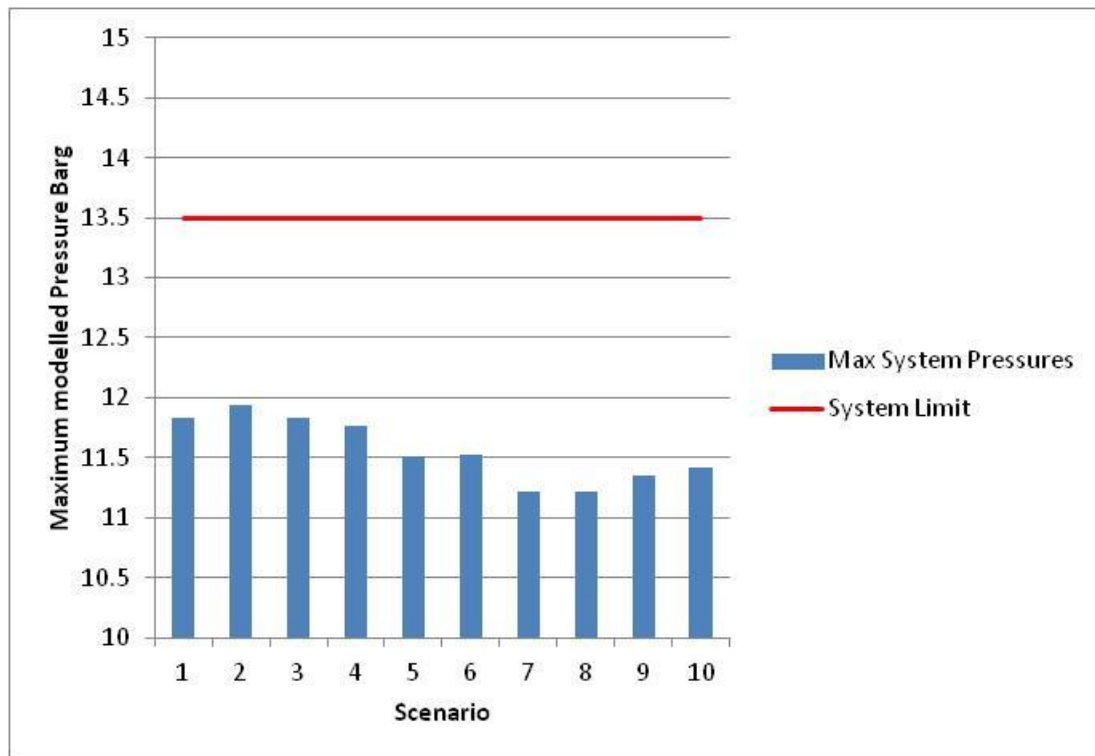

Figure 133: Predicted Pressures per Scenario

The predicted temperature response, as shown in Figure 134, highlights important issues at the extremities of the distribution circuit, namely the Coke Ovens. Resulting in saturated

steam and not the superheated steam required at the Coke Ovens to satisfactorily operate the turbine drives.

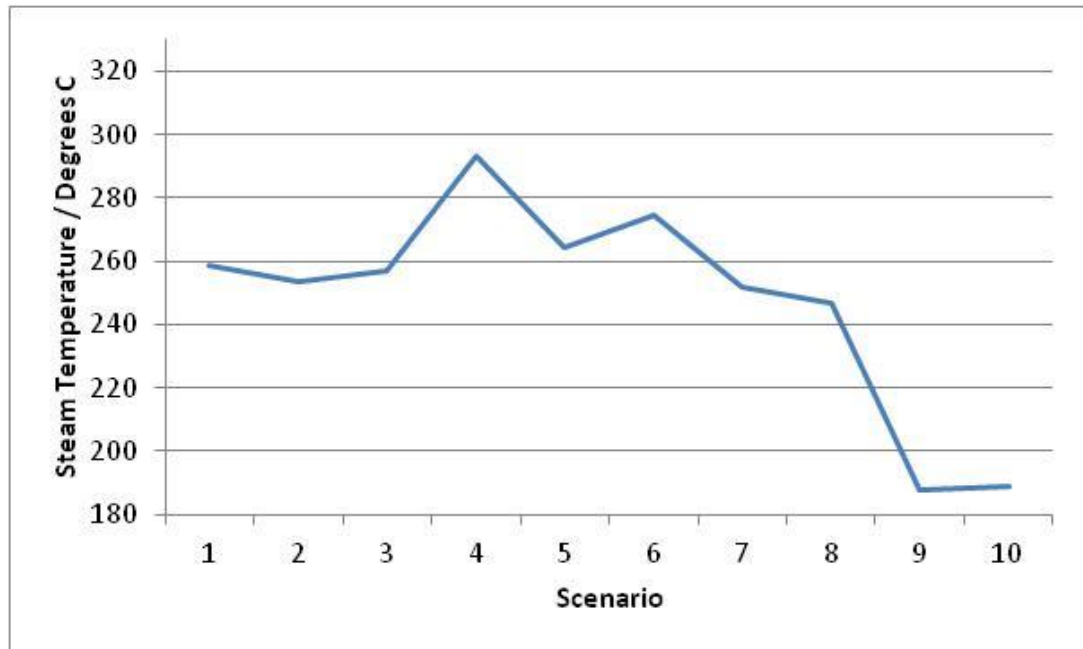

Figure 134: Steam temperature per scenario

Figure 135 shows that scenarios 8 and 9 are those that result in the south end importing steam. As scenario 10 exports steam but results in low steam temperatures at the Coke Ovens it can be concluded that the low predicted steam temperatures at the Coke Ovens issue does not correlate with input/output mass balances.

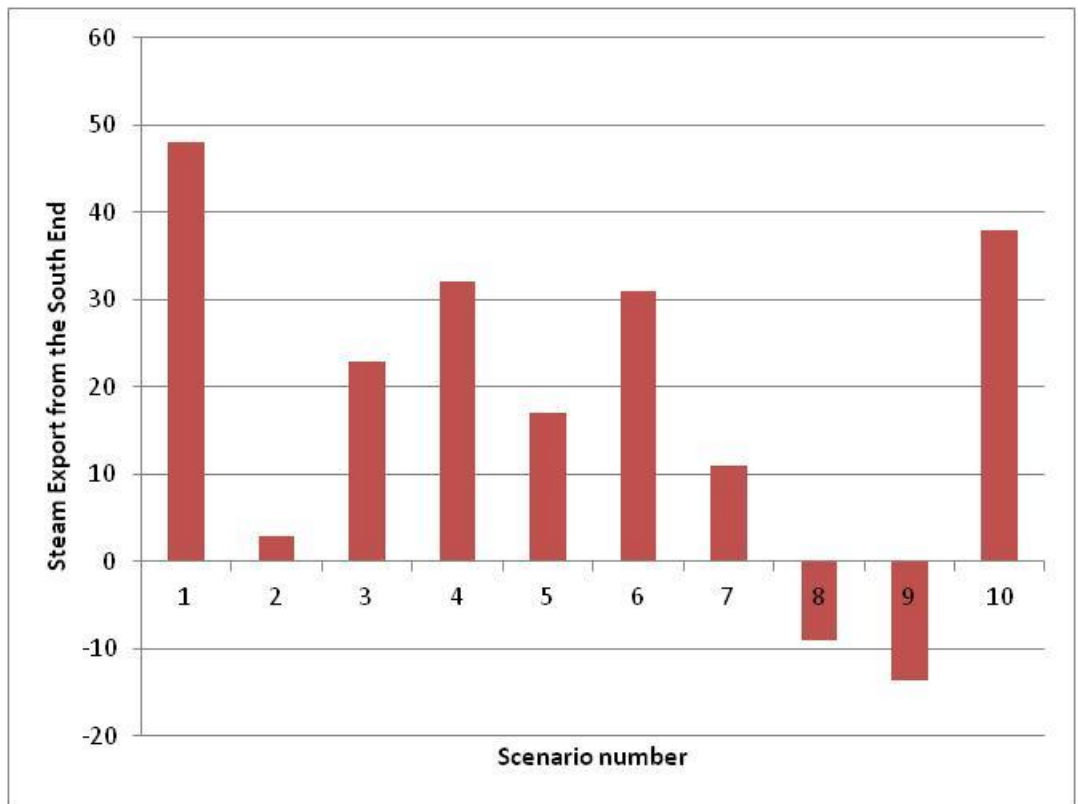

Figure 135: South End Import / Export

The model itself was examined further and it was found that it was again due to a local south west issue similar to that shown in section 6.2, Figure 116. As per section 6.2 increasing the output of the service boilers for this scenario improves the steam temperature at the Coke Ovens as shown in Figure 136. As shown in Figure 136 increasing the service boilers output from 40 to 43tph is sufficient to raise the steam temperature to 250 °C which is above the minimum 240°C as stated in section 6.2.a.

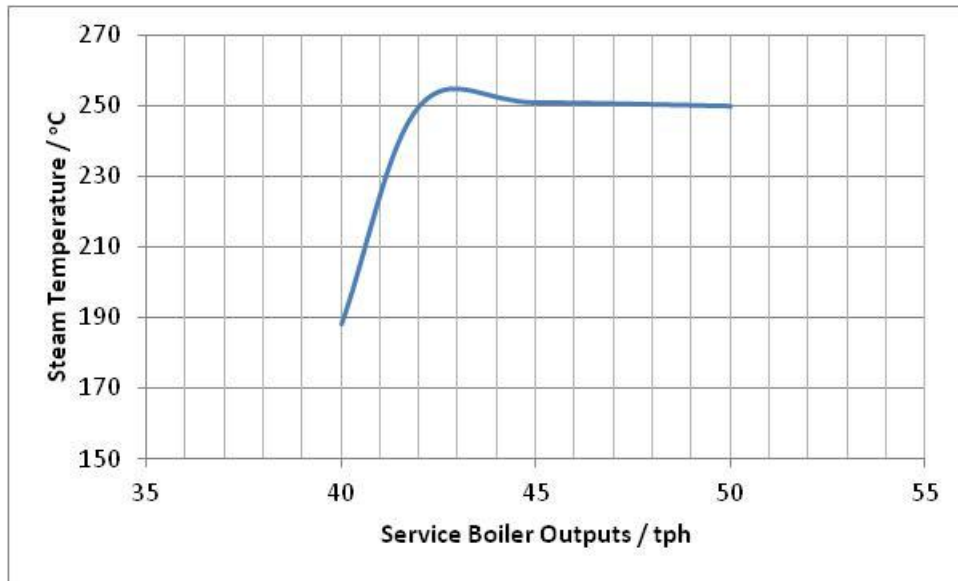

Figure 136 Scenario 10 Coke Ovens Temperature vs Service Boiler output

Figure 137 shows that the predicted pressure increase is marginal for scenario 10 as the Service Boiler outputs are increased.

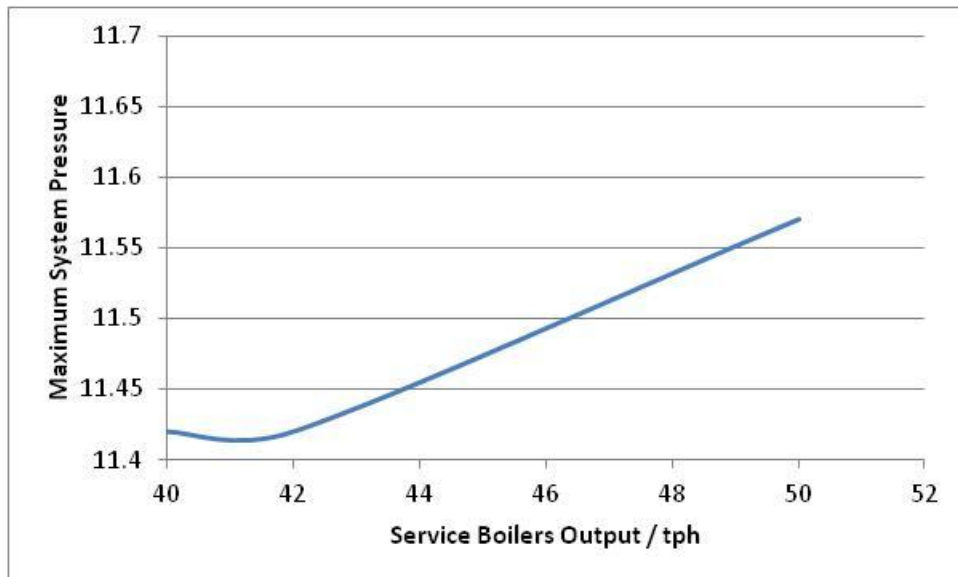

Figure 137 Scenario 10 Maximum system pressure vs Service Boiler Output

As discussed in Chapter 3, the conversion from a water cooling system to an evaporative cooling system is simply too disruptive for consideration. However, when the works decides it needs to overhaul a furnace or needs to add an additional furnace then this analyses has shown that the 11bar system can act as an end use for the energy recovered. The analysis also demonstrates the importance of continuous monitoring of the distribution systems pressures and temperatures with the Coke Ovens being of particular importance. This will then allow the ability to control the output of the service boilers and thus ensure that the steam delivered to the works areas is of sufficient temperature and pressures.

6.6. Taking the Service Boilers off-line

The next part of the study was to answer the question “with all the WHR boilers installed can the service boilers be removed?” By referring to Figure 138 the answer has to be “no”, as the system temperature falls below the minimum operating values for the Coke Ovens. The model was run through the ten scenarios but with the Service Boilers turned off. As can be seen in the figure the pressures are acceptable at the Coke Ovens but the temperature loss is excessive and as previously stated the temperature drops below the minimum. For Scenario 7, Figure 138 highlights that the temperature at the Coke Ovens drops, below 188°C and therefore the steam is at a saturated state which is too low for use in the local steam turbines.

With the current setup of the case study works, the service boilers will always be required to operate in some form or another to ensure adequate supply of steam to the South end of the works. With consumers flexing their consumption and the WHR boilers flexing their outputs the study shows that there are scenarios that will require the assistance of the Service Boilers. As discussed earlier it would perhaps be better if the Service Boilers were

in pressure control but as shown in Figure 138 there also needs to be the ability to increase the output to maintain the correct steam temperatures at the Coke Ovens.

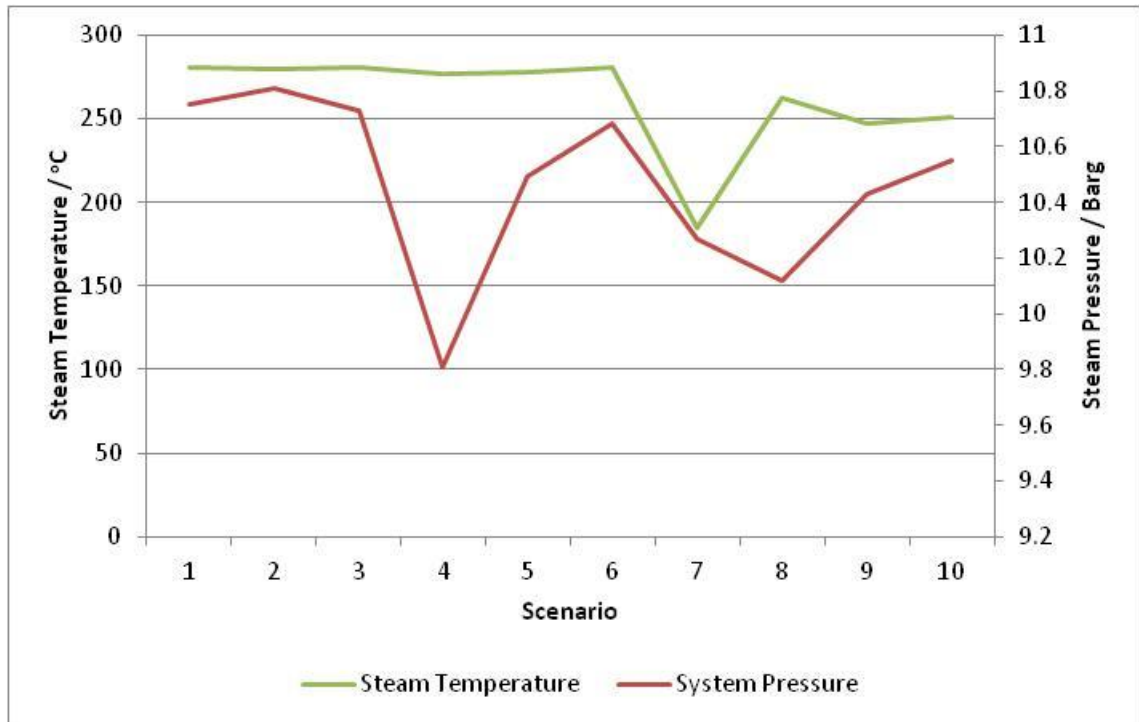

Figure 138 Steam temperatures and Pressures per scenario

Figure 139 shows the predicted net pressure effect of the WHR boilers as they are added to the distribution system. As shown the maximum predicted pressure increases in steps as the WHR boilers are added. As the BOS and CAPL WHR boilers are added the maximum system pressure approaches the maximum allowed of 13.5barg. The addition of the proposed Sinter Plant WHR boiler then potentially takes the pressure above the maximum threshold and so the service boiler outputs need to be decreased.

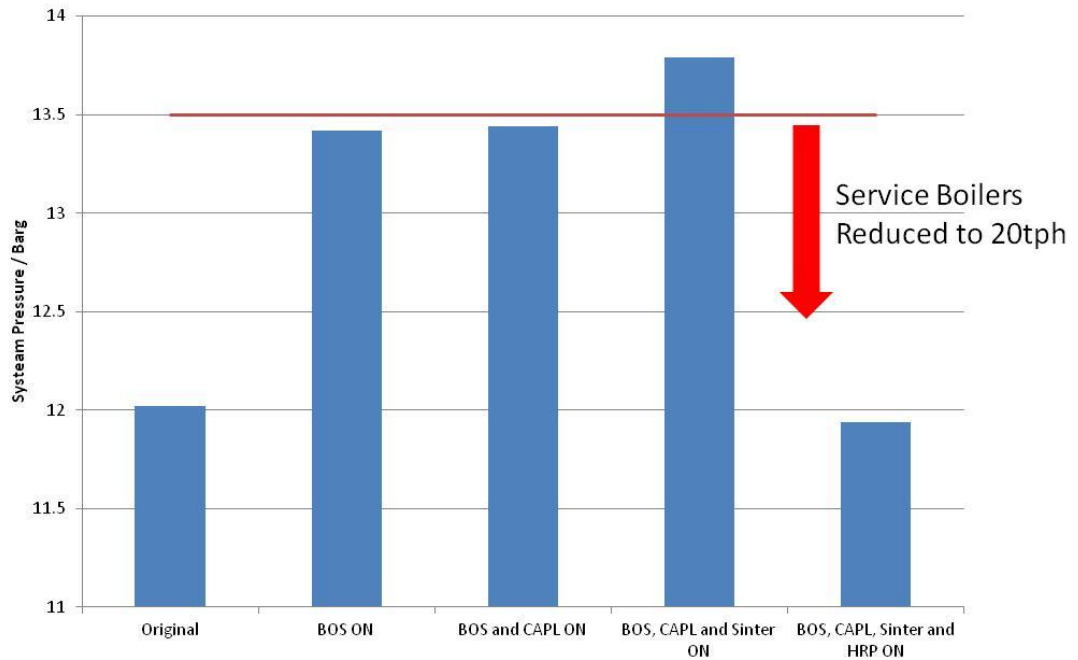

Figure 139: System Pressure with the addition of WHR boilers

As stated the BOS plant WHR boiler investment with the new TA within the 11 barg steam system, with increased Service Boiler output has saved £8m and 54,000t of CO₂ by December 2014. The project has been Referenced in Imperial colleges (Element 2014) report for the DECC document Heat Strategy. As a result of this the project the Steam distribution system is now seen as an essential asset for the case study works. This has released the future potential benefits from steam savers. The case study works can now review steam consumers and determine if they can be replaced by utilising medium or low grade waste heat recovery techniques. Any saving of 11 barg steam now increases the quantity of steam available for electrical generation through the new TA and thus create a financial benefit and payback for any investment. The works is also looking at ways of maximising the efficiency of the 11 barg steam system to reduce steam losses through improved insulation, reduced leaks and improved trapping.

6.7 Summary

This chapter describes the completion of Aim 4 through the modelling the impact of potential WHR boilers on the CSSW steam distribution Circuit. Chapter 5 described the building and verification of the model against plant data, this chapter describes the use of the model for simulating the addition of WHR boilers. The model is used to simulate the addition of WHR boilers to the BOS plant, CAPL, Sinter Plant and HSM. Pressure and temperature predictions are plotted and recommendations are made to ensure the system does not exceed its maximum pressure limit. The results show that the steam system can accommodate the WHR boilers but the Service Boilers output would have to be reduced to ensure that the distribution system did not exceed the maximum rated pressure of 13.5 barg for certain configurations. The modelling also predicts that the Service Boilers output must be maximised for other scenarios to ensure an adequate steam temperature at the Coke Ovens. It can therefore be stated that the ability to vary the Service Boiler output is critical to the successful use of the steam distribution system as an end use for the steam from future WHR boilers.

As stated the BOS plant WHR boiler investment with the new TA within the 11 barg steam system, with increased Service Boiler output has saved £8m and 54,000t of CO₂ by December 2014. The project has been Referenced in Imperial colleges (Element 2014) report for the DECC document Heat Strategy. As a result of this the project the Steam distribution system is now seen as an essential asset for the case study works. This has released the future potential benefits from steam savers. The case study works can now review steam consumers and determine if they can be replaced by utilising medium or low grade waste heat recovery techniques. Any saving of 11 barg steam now increases the

quantity of steam available for electrical generation through the new TA and thus create a financial benefit and payback for any investment. The works is also looking at ways of maximising the efficiency of the 11 barg steam system to reduce steam losses through improved insulation, reduced leaks and improved trapping.

7. Overall Heat Strategy

7.1 Introduction

Modelling the 11 barg steam distribution has provided the ability to simulate an ‘end-use’ for Waste Heat Recovery [WHR] projects for the case study works. The concept of using the 11 barg steam main to connect the projects together and provide an ‘end-use’ via the new Turbine Alternator [TA] became known within the CSSW as the ‘Centralised Heat Recovery Investment Strategy’ or abbreviated to ‘CHRIS’. WHR boilers can now be simply plugged into the existing steam main and use the electrical generation from the TA for the benefits case. This concept eliminates the need for future projects to install expensive steam mains and individual TA’s. The Fluidflow3 model enables the simulation of the boilers modelling pressure and temperature thus ensuring the optimum end-use for each project is obtained. The strategy has also realised some relatively low cost benefits by transforming the 11 barg steam distribution main from what was seen as an old, tired and inefficient system into a valuable asset that is essential to the future sustainability of the works. Figure 140 shows the concept of the strategy in that WHR projects can be plugged into the steam mains but as shown by the modelling work the phasing of the projects is critical for pressure and temperature control of the steam system. The modelling work has demonstrated that each project needs to be modelled individually before it can be sure that the correct option is chosen and the business case benefits can be realised. The installation programme order is unknown at this point in time so it is essential that the model is continually updated and modified as the projects are installed. The timings of the projects can have huge effect on the validity of the business case. Too much pressure in the south end will result in the service boilers reducing output and therefore the gas being flared.

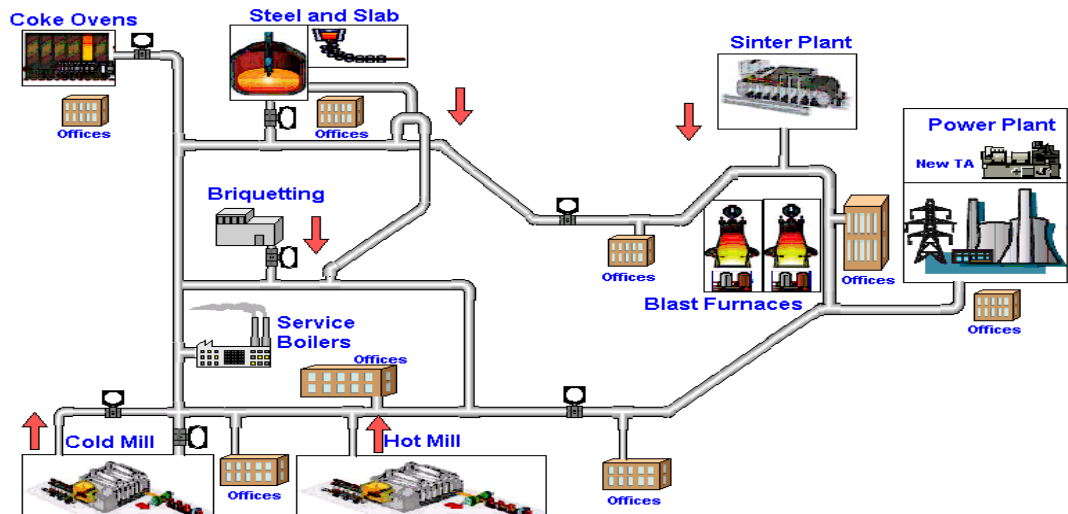

Figure 140 Schematic of the WHR projects

As defined in Chapter 3 many of the projects have long paybacks and therefore as retrofit projects would not be financially viable. As demonstrated by the BOS plant project, by building WHR into an ‘essential replacement’ type project the business is more likely to invest. Therefore another benefit of this strategy is that the case study works already has an end-use for WHR projects therefore simplifying the options analysis. Therefore whenever the works is considering the essential replacement of a piece of equipment then this strategy can be referred to and the model utilised to assess its full benefits. Even as part of an essential replacement some projects will still suffer long paybacks, therefore external benefits will help the business make the investment decision. Potential Government incentives could assist in the near future and are being explored by the Department of Energy and Climate Change [DECC]. The ‘Future of Heating’ (DECC 2012b) looks at the potential benefit of industrial waste heat to the UK in general and therefore DECC are starting to see industry as part of the UKs energy solution not as just part of the problem. Figure 141 shows an extract from this DECC document showing how the BOS WHR

project has been discussed as a case study. The supporting research supported by Imperial College London (Energy 2014b) also references this project as a case study example of Industrial WHR.

Box 2: Generating Electricity from Surplus BOS Gas Heat at Port Talbot (2012) – £53m

The integrated steelworks at Port Talbot produces 4.7 million tonnes of steel per year. The site employs 3600 people, supporting a further 14,000 jobs in South Wales through the supply chain. Tata recently replaced the basic oxygen steelmaking (BOS) gas cooling system with a new evaporative cooling system, including upgrades to the existing steam network and the installation of a new steam turbine.

Completed in December 2012, the new cooling system allows the site to recover waste heat to generate 40 tonnes of steam per hour to be used for process heating or electricity generation. The new slightly over-sized steam turbine also ensures that all available steam will be used, whether it is generated from process gases or the surplus heat. As a result, on-site electricity generation will increase by 10 MWe per annum, in turn making a 2.5m investment in a waste heat recovery system economically viable. This will result in a further 1 MWe increase in electricity generation.

Waste Heat Boiler Ducting at Tata Port Talbot (Courtesy of Tata Steel)



Source: Tata Steel

Figure 141 Extract from DECC ‘The Future of Heating’

Figure 142 shows a diagrammatic Sankey diagram of how the 11bar steam system can now be used to integrate ‘Heat’ for the CSSW. The 11 barg steam system can link ‘heat consumers’ and ‘waste heat recovery opportunities’. The new TA then provides the ability to generate electricity with any surplus heat.

The figure demonstrates that:-

- a) The indigenous gases are used for electrical generation in the Power Plant.
- b) High grade WHR is used to supply the steam consumers and further electrical generation.
- c) Low and Medium WHR technologies are used to supply the necessary heat to an internal district heating network and an external district heating networks
- d) The New TA off the 11Barg system now gives an energy and financial benefit to any inefficiencies present in the steam system for example leaks and insulation losses.

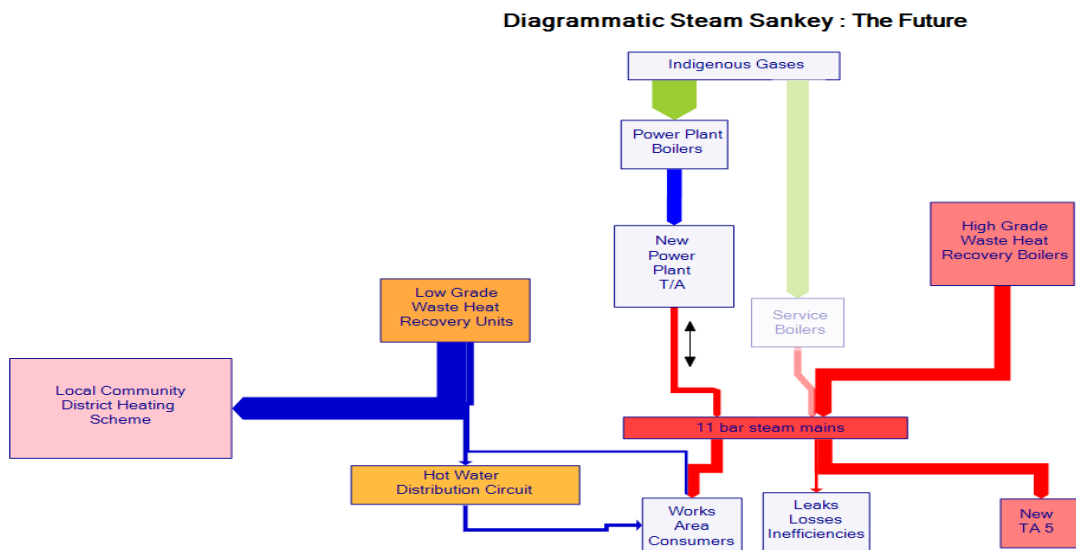

Figure 142: Diagrammatic Steam and Heat Recovery Sankey Diagram

7.2 LOW Grade WHR opportunities

Several low grade WHR opportunities were explored. The site has invested in air source heat pumps which were being used for building heating instead of steam. The air source heat pump installations proved to be successful trials for the case study works. Other schemes were explored, for example the main office blocks, all of which are currently

steam heated off the 11bar steam main. Conversion to air source heat pump and also heat pumps, utilising a local warm water source from a cooling tower, were explored. The paybacks for both though were greater than 5 years and thus the CSSW deemed this long payback as excessive and financially unviable under current business conditions. An example Organic Rankin Cycle [ORC] was investigated utilising some of the low pressure steam off the CAPL WHB. The principle of this investigation was to generate electricity directly off the low pressure steam. Again though, the return on investment was not good enough for the case study works. One of the main issues with the low grade heat options is the simple scale of the works. Heat sources and heat consumers are rarely adjacent to each other. The necessary services are also some distance away so when the concept starts to be priced up into a project the costs start to increase rapidly.

Part way through the investigation it was identified that the CAPL Hot Gas Jet Cool was in fact a high grade water heat source being cooled by a plate heat exchanger. The plate heat exchanger is cooling the gases down from 600°C to 400°C via cooling water and a cooling tower. CMI (CMI 2012) are developing a different arrangement of heat exchangers to export up to 18MW thermal of water at 120°C that can either be used for district heating or connected to an ORC. Again this is not yet at the commercial scale but the opportunity is being explored. This water at 120°C at the South end of the Steam works would be ideal for an internal district heating scheme that would be used for Process, Office and Bay heating and thus displace the 11bar steam enabling it to be used for electrical generation instead.

The issues with the uptake of low grade waste heat recovery projects are in essence the same as those discussed by the Tyndel Centre (Manchester 2010a). In essence the same headings can be applied for low grade WHR as those discussed in Chapter 3 i.e. Quantity,

Technology, and end-use. Low Grade waste heat is now being ‘Quantified’ more readily, there are more lower cost ‘Technologies’ becoming commercially but the often the issue can be the availability of, or the cost of, the ‘end-use’.

7.3 District Heating Internal

As described in Chapter 4, Figure 143, shows a PIE chart of the 11barg consumers in the case study works. As can be seen over half of the steam consumption is for process, building and office heating. All of which could be supplied with hot water rather than steam. This hot water could potentially be heated from lower grade waste heat sources.

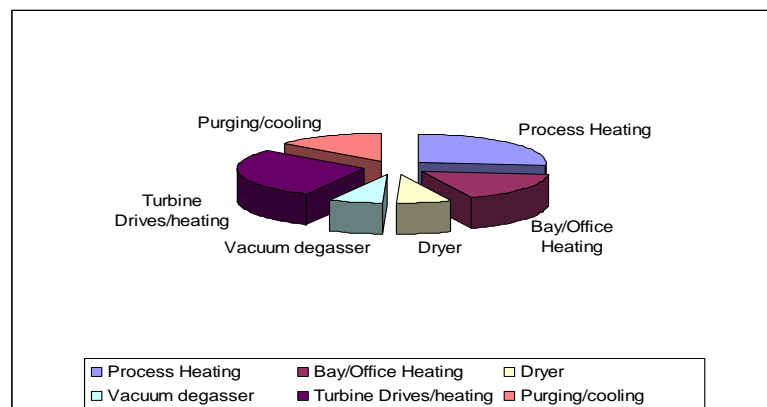

Figure 143: Steam Consumers

An internal district heating scheme could therefore be created that utilised a few low grade waste heat sources. This would reduce 11barg demand by 40 tph and the number of small diameter pipe runs would reduce significantly thus improving system efficiencies. A project team was formed at the CSSW to assess the installation cost of such an internal district heating scheme. Unfortunately due to resource constraints the project was put on hold but a rough early stage budget cost of £7 million was estimated. The Cold Mill and CAPL systems would primarily be supplied with low pressure steam from the CAPL WHR boiler

and so the average winter 11bar steam saving would be in the order of 33 tph which when supplied to the new TA would produce a benefit of £1.7 million for the winter period.

7.4 District Heating External

According to DECC (DECC 2014) there are approximately 2,000 heat networks in the UK currently, supplying heat to more than 200,000 dwellings and more than 1,500 commercial and public buildings. A further 150 schemes are estimated to be under development by local authorities across the UK. Estimates show that approximately 15% of UK heat demand could be met by heat networks by 2030 and around 50% by 2050, making a cost effective contribution to the UK's decarbonisation targets.

Regarding district heating examples, utilising steelworks as the heat source, an award winning case study is that of Dunkirk (Awards 2009). In operation since 1985 the Dunkirk example could very well be replicated in the area surrounding the CSSW. As shown in Figure 144, WHR [28MW] from the sinter plant cooler at the local steel works is used as the main heat source. Around 70% of the heat supplied is from the WHR on the sinter plants.

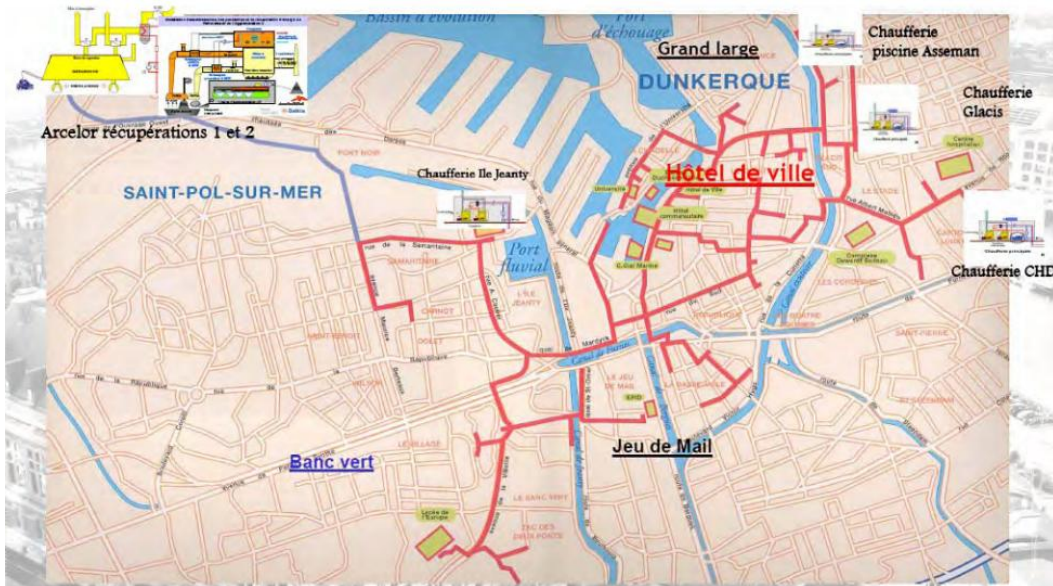

Figure 144: District Heating Example

Figure 145 shows an overview of the WHR unit above the sinter cooler and the district heating interface. The figure demonstrates the issue of the dust collection system that would need to be built into the WHR unit.

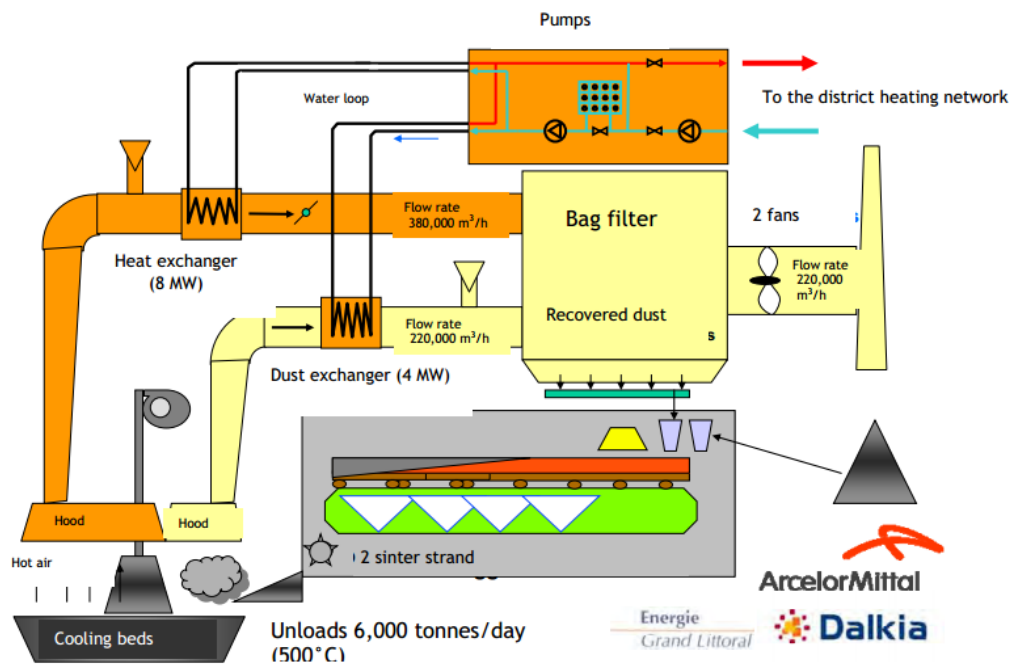

Figure 145: Example Heat Recovery from Sinter Cooler

In the UK, Newcastle University (Newcastle University 2011) discuss District Heating in Port Talbot as a potentially viable case study and state that the heat map produced by the Department of Environment, Food and Rural Affairs [DEFRA] is used to determine the heat potential from the demand side. Most of the heat demand is located more than 9 km away from the heat sources identified in the steelworks. Within a radius of 25 km, the potential heat demand is approximately 155 MW and most of the heat demand comes from households. Figure 146 shows the potential network being explored by Neath Port Talbot County Borough Council [NPTCBC] in their ‘Local Development Plan 2011 to 2026’ (NPTCBC 2013). As shown the heat network could potentially have a few heat sources, the CSSW being one of them.

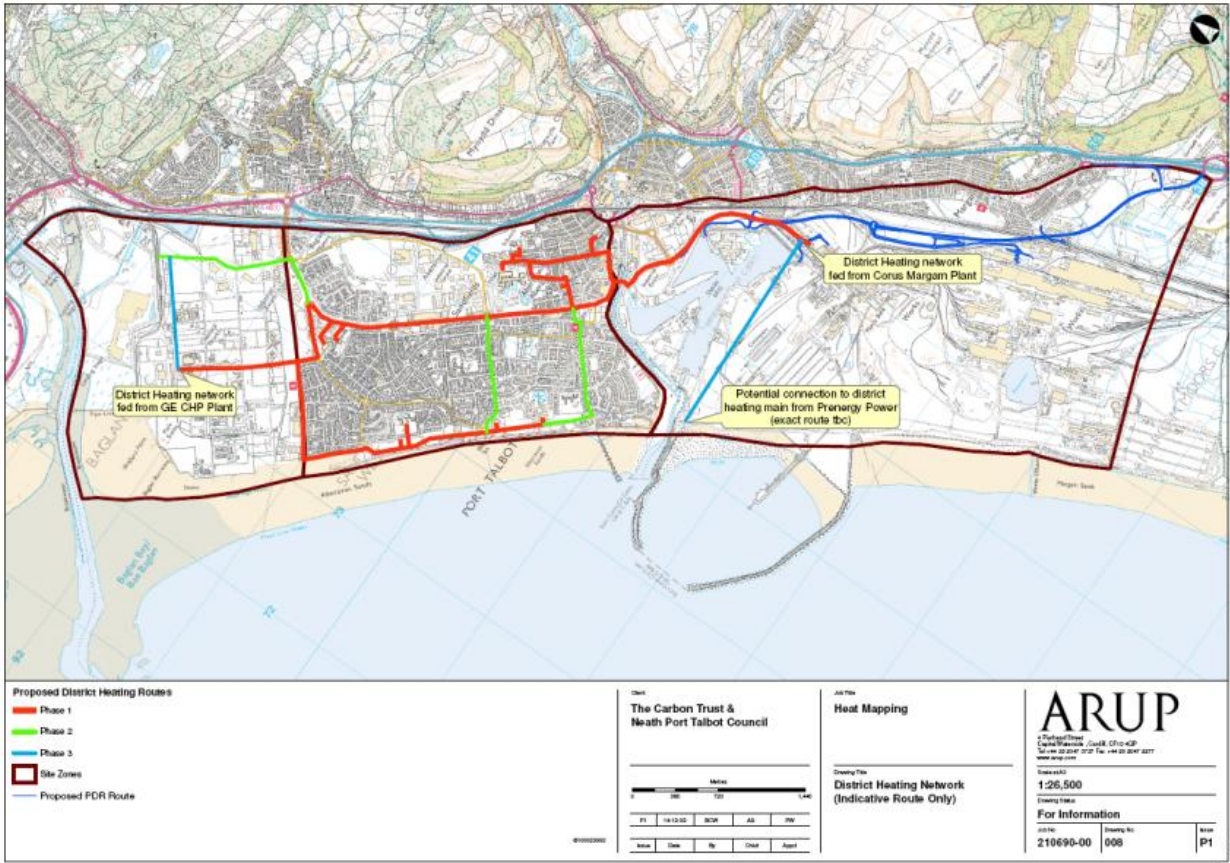

Figure 146 District Heating Proposition (NPTCBC 2013)

To understand local opinion Manchester University conducted a survey with the local community. Of the three thousand forms sent out they had around 311 replies of which Figure 147 shows a graph from one of the questions asked ‘District Heating Sounds a good idea in Principle’. The majority of answers to all the questions were positive as long as there was a financial benefit for the house holder and there wasn’t a long term contractual obligation.

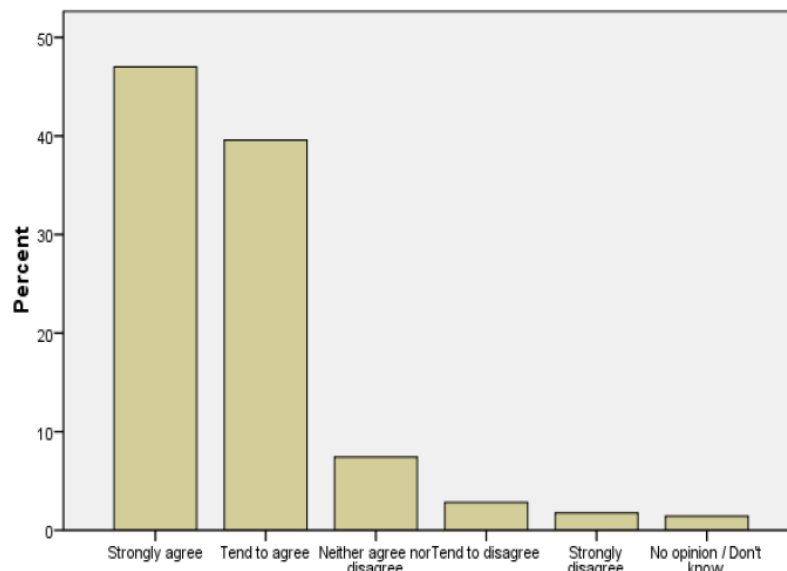

Figure 147 District Heating Questionnaire (Manchester 2010)

Industrial low grade heat can therefore be integrated into a new district heating scheme to heat the community. Linking the CSSW to a District Heating scheme does therefore look an attractive option and a win-win situation. Using the sinter cooler to first generate steam for electrical generation and then use the lower temperature segment for the district heating supply should form an attractive business case for the case study works and NPTCBC.

Very difficult to calculate the benefit to the case study works as it will depend on the contractual agreements reached. If the energy value was priced at the same level as Natural Gas [i.e. £7 per GJ]. Then the financial value would be calculated as, the amount of heat available is 10MW_{TH} , over the winter period, would equal a total of 43,680 MWh or

157,248G J, at£7 per GJ, therefore approximately £1.1m per year. There would be a heat requirement all year for the hospitals, schools and swimming pools but therefore would be a reduction in benefit from efficiency losses. All this would be built into the financial model agreed with the District Heating Organisation.

7.5 Steam System Optimisation

As discussed in Chapter 4 Cardiff University and Spirax Sarco surveyed the steam distribution circuit and efficiency improvements were identified. These insulation and trapping improvements, as well as the mass loss from the steam leaks, were then modelled and the new result assessed. Insulation improvements were simulated on the model as well as reduced mass loss due to improve steam trapping and leaks. The new TA installed as part of the BOS plant WHR boiler project now provides a payback for steam system energy efficiency improvements. In order to maximise the potential benefits the works embarked on a Steam System improvement program that incorporated repairs but also education. With the co-operation of the Carbon Trust a Welsh Steam users workshop was held at the case study works titled “Making Sense of Steam” (Carbon Trust 2012).

7.6 De-centralisation of the steam system

Full decentralisation, for the purposes of this work, is defined as the steam consumers in each works area being supplied by local WHR boilers and local Turbine Alternators. So full decentralisation would alleviate the need for the steam distribution circuit and therefore significantly reduce distribution losses. However, full decentralisation cannot be deemed a viable option because of the requirement to maintain a guaranteed continuity of supply to the steam consumers. This requirement would necessitate the installation of standby steam boilers to enable a continuous steam supply when the WHR boilers are taken off-line for

maintenance, or steelmaking production delays. Thus each works area would require the large capital investment of additional local boilers that would only be used for standby steam supplies. Therefore the cost of the boilers, on top of the local TAs, would significantly increase the capital cost and thus extend the payback period beyond what would be considered beneficial for the CSSW.

However, in order to explore the concept of a reduction in the size of the steam system, a partial de-centralisation model was configured as shown in Figure 148. The model was broken into two discrete sections by eliminating the two long steam mains that connect the North and South Ends of the works. For the South End, with up to 100tph generation from the WHR boilers plus the potential of steam from the service boilers, the 'end use' for the steam is critical. To balance the mass flows for the South End a new TA had to be built into the model adjacent to the service boilers. This TA was programmed to be in pressure control and thus would respond to the variability in consumption and generation of the South End. The TA would be required to have an input range of 25-100tph to balance the steam generation from the WHR boilers and the remaining steam consumers.

The model was run through a new series of scenarios to simulate the various mass flows from the WHR boilers and the Steam consumers. Figure 149 shows the outcome of the modelling for the scenario with the highest system pressures (ie maximum steam make from the boilers and minimum steam consumption from the works areas) indicating that both systems remain within the pressure limit of 13.5barg. This is expected as the TA is in Pressure Control but it clearly shows that the remainder of the distribution system is capable of withstanding the increased generation from the new WHR boilers.

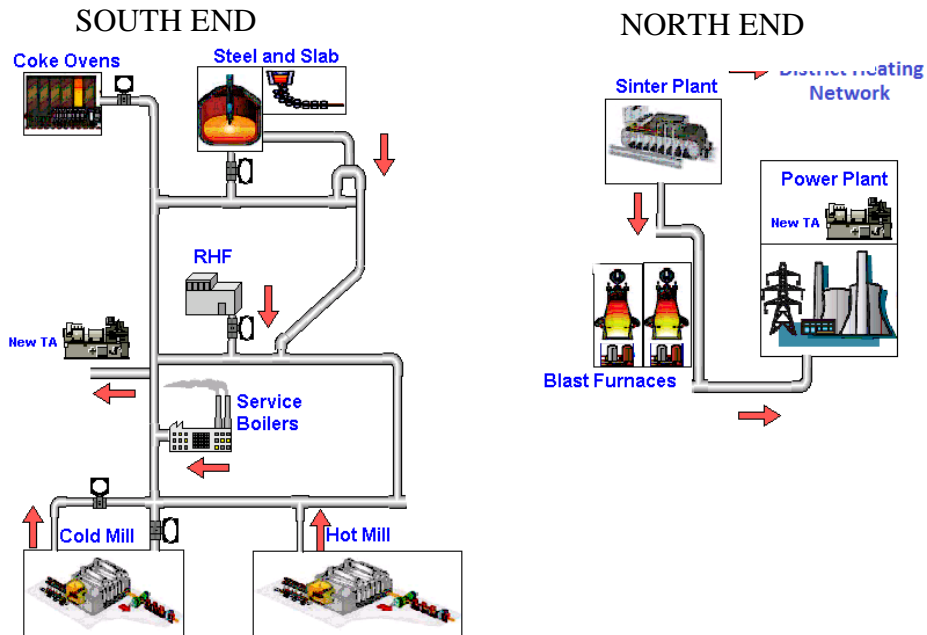

Figure 148: Partial De-Centralisation

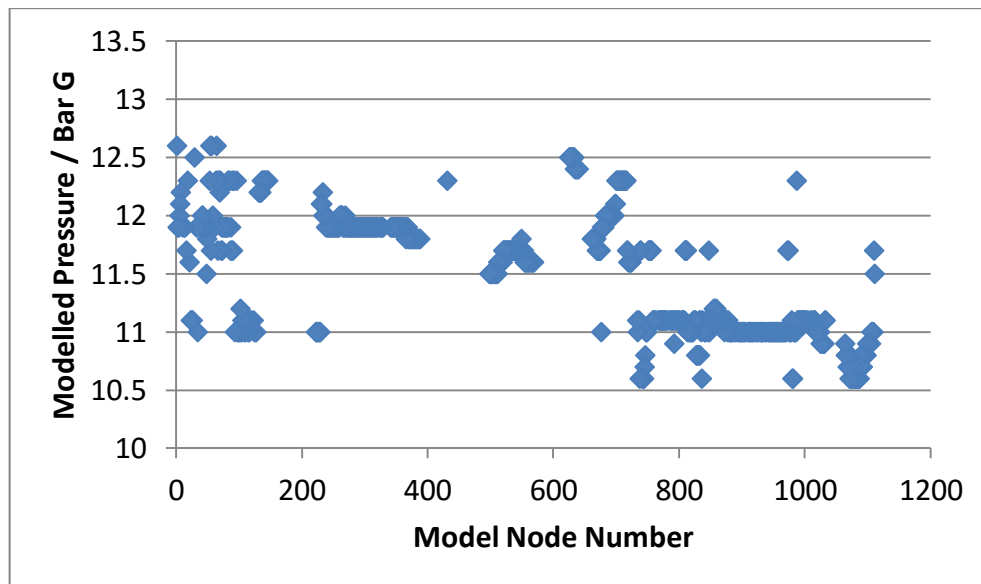

Figure 149: Partial De-centralisation Modelling results

The main advantage of this proposal is the efficiency gain from the losses associated with the two long steam mains, that is, the steam from the South end would no longer be exported all the way to the North End. The model predicts a gain of an equivalent to 6tph of steam, which through the new TA, equates to 1MWe or £600k per year. The TA installation

would cost around £4M (based on the costs of TA5 for the BOS project) and therefore, with a 7 year payback, it is very unlikely that the CSSW would invest in this proposal. As financial constraints change and government incentives potentially arise this option could present the optimum solution for the CSSW. By illuminating the need for individual standby boilers, plus TAs for each works area, the solution minimises potential investment in comparison to the complete decentralisation option. Partial decentralisation, therefore, may well prove to be the optimum solution. As new projects are considered for the CSSW it is therefore important that partial de-centralisation is modelled and considered.

8. Conclusions

8.1 Review of Thesis Aims

Chapter 1 defined the five aims of the thesis as being:-

1. ***“Study UK based CSSW, Study its energy flows, compare against BAT and identify a technology not yet employed to improve Energy Efficiency.”***

This aim was completed in Chapter 2. The energy flows of the CSSW have been analysed and compared to BAT. It has therefore been identified that WHR is a potential technology not yet fully utilised by the CSSW

2. ***“Research that technology”***.

This aim was completed in Chapter 3. WHR has been researched and reported both as a general subject but also applied directly to the steel industry and for the CSSW on particular.

3. ***“Investigate the potential impact on the CSSW”***.

This aim was completed in Chapter 4. The application of high grade WHR technologies is explored through a detailed understanding and analysis of the existing CSSW steam distribution circuit.

4. ***“Model the technologies implementation”***.

This aim was completed in Chapters 5 & 6. A model has been developed of the 26km CSSW steam distribution circuit. Through comparison with theoretical calculation and actual plant data for defined operational scenarios, the model has been fully verified. The

CSSW in 2013 subsequently made the investment in the first WHR boiler at the BOS plant and the new Turbine Alternator. This new TA has generated over £18 million of electricity up to December 2015.

5. *“Scope a strategic outlook for the CSSW”.*

This aim was complete in Chapter 7. A strategy is presented that utilises low grade WHR to displace steam consumption and high grade WHR to generate steam for electrical generation. The model is also used to explore the further option of partial de-centralisation of the steam distribution circuit. The model is split into two distinct circuits for the North and South ends of the CSSW. The model incorporates all high grade WHR options for electrical generation and low grade WHR is used to displace steam consumers and export heat for local community district heating.

8.2 Conclusions

1. The modelling has proved that the 11 barg steam system can be utilised as an ‘end use’ for high grade waste heat recovery projects for the case study works. The modelling demonstrated that:-

- The system can potentially be over pressurised and therefore continuous monitoring is essential for safe operation. This necessitates a new focus, for the case study works, to ensure reliable metering and thus ensure protection of the steam system. Improved monitoring is also required to protect the consumers from low steam temperatures.
- With the current configuration of plant, the Service Boilers are essential to ensure the steam temperatures remain sufficient at the Coke Ovens.

- The ability to flex the Service Boilers output to protect the system from over pressurisation is demonstrated by the modelling work.
2. Two WHR projects have been supported by this project helping the works invest over £55m and save over £7m per year in energy thus reducing carbon dioxide emissions by 50,000tonnes of Carbon Dioxide per year.
 3. The new TA has transformed the value of the steam system to the case study works. Steam savings now equal monetary savings thus ensuring there is a driver for efficiency.
 4. The research and modelling has provided the case study works with a strategic overview to ensure that WHR projects are more easily considered in the future. As various pieces of equipment require essential replacement this strategy will ensure that WHR is considered as part of the options analysis.

9. Recommendations and Further Work

- To ensure the models validity, continue to develop the model by comparison to plant data. As insulation deteriorates or is replaced through planned maintenance the characteristics of the system will change. Also, as soon as the steam meters are made operational conduct a new validation exercise and reassess the accuracy of the model.
- Develop low grade waste heat projects as ‘steam savers’ to increase electrical generation and also help towards some decentralization. Many of the steam consumers are at extremities of the steam system. Often the calculated distribution losses are greater than consumer itself.
- Explore the high grade WHR option for Sinter Plant and combine with the District Heating investigation being conducted by the local council. The model can be used to help assess the options.
- Use the model to help assess the case study works with options for the new power plant being investigated by the CSSW. The model will enable simulation of the new inputs and outputs for the new Power plant and its associated modifications
- Re-assess the partial de-centralisation of the steam system on an ongoing basis as WHR projects are considered.

10. References

Accutech. 2013a. *Fluid Mechanics Refresher*. Available at:
<http://www.accutech2000.com.au/FluidFlow3/Support/Modelling%20and%20Design%20Notes/Modelling%20and%20Design%20Contents.html> [Accessed.

Accutech . 2013b. *Fluidflow 3 Training Manual*. Available at:

<http://www.accutech2000.com.au/FluidFlow3/Support/Modelling%20and%20Design%20Notes/Modelling%20and%20Design%20Contents.html> [Accessed.

Accutech. 2014a. *FLUIDFLOW3: MODELLING AND DESIGN NOTES* [Online].

Available at:

<http://www.accutech2000.com.au/FluidFlow3/Support/Modelling%20and%20Design%20Notes/Modelling%20and%20Design%20Contents.html> [Accessed.

Accutech. 2014b. *Fluidflow 3 overview*. Available at:

<http://www.accutech2000.com.au/index.html>

Hayes , Sara, ACEEE. American Council for an Energy Efficient Economy,2012.

International Energy Efficiency Scorecard. Available at:

http://www.profitablegreensolutions.com/sites/default/files/resources/media/ACEEE%20Report%20on%20National%20Energy%20Rankings_0.pdf

AISI. 2014. *How a Blast Furnace Works* [Online]. Available at:

<http://www.steel.org/Making%20Steel/How%20Its%20Made/Processes/How%20A%20Blast%20Furnace%20Works%20larry%20says%20to%20delete.aspx> [Accessed.

Allwood, J. M. and Cullen, J. M. 2012. *Sustainable Materials: with both eyes open*. UIT Cambridge Ltd.

ASTM. 2014. *Standard Practice for Estimate of the Heat Gain or Loss and the Surface Temperatures of Insulated Flat, Cylindrical, and Spherical Systems by Use of Computer Programs*. ASTM International.

Atkins, J. 2011. *The Use of Accumulators to Store Steam*. Cardiff University Project Number 70 (Tony Griffiths supervisor).

Awards, G. D. E. C. 2009. *District Heating Network – Dunkirk*. Available at

<http://www.districtenergy.org/assets/CDEA/Case-Studies/Copenhagen-Energy-SummitDunkerque-France-submission.pdf>

BERR. 2008. *Heat Call for Evidence*. Department for Business Enterprise & Regulatory Reform: London.

Blair, A. M., *The British Iron and Steel industry since 1945*, Journal of European Economic History 3rd Edition. 1997

Bratland, O. 2009. *Pipe Flow 1 Single-phase Flow Assurance*. Available at:

<http://www.drbratland.com/>

- Bratland, O. 2010. *Pipe Flow 2 Multi-phase Flow Assurance*. Available at <http://www.drbratland.com/>
- Brown, D. 1991. *Energy Audit of Steam Distribution in the trunk mains and steam usage by ancillary users*. Cardiff University ref: TCS/UWCC/AGS/3/91/02.
- Burggraaf, B. 2011. Conference paper, *Energy Optimisation Team*. International Conference on Energy Efficiency and CO2 Reduction in the Steel Industry.
- Case, P. L. et al. 1996. *Steam Dispatch—Energy Savings for Distributed Steam Heating Systems*. ACEEE Summer Study.
- Centre, Japan Coal Energy. 2015. *Coke Dry Quenching Technology*. Available at: http://www.jcoal.or.jp/eng/cctinjapan/2_3A5.pdf
- Chisholm, J. 2010. *Analyses of a low pressure steam distribution network at an integrated steelworks*. Cardiff University.
- Climate, A. P. P. f. C. D. a. 2010. *The State-of-the-Art Clean Technologies (SOACT) for Steelmaking Handbook (2nd Edition)*.
- CMI. 2012. *Waste Heat Recovery Opportunities*. Presentation given to Tata Steel.
- Coopers, Price Waterhouse. 2014. *Tata Steel. Understanding the economic contribution of the Foundation Industries*. Available at: http://www.tatasteeleurope.com/file_source/StaticFiles/Functions/Media/Foundation_Industries_Report.pdf
- Crane. 1982. *Flow of fluids through valves, fittings and pipe*. Technical Paper No.410 M.Crane Co.
- de Beer, B. J. et al. 1998. *Future Technologies for Energy-efficient Iron and Steelmaking*. *Annu. Rev. Energy Environ.* 1998. 23:123–205.
- De Melo, R. R. 1992. *Modelling of an industrial steam distribution system*. Cardiff University Report Number 1678.
- DECC. 2011. *Planning our electric future: a White Paper for secure, affordable and low-carbon electricity*. Available at: https://www.gov.uk/government/uploads/system/uploads/attachment_data/file/48129/2176-emr-white-paper.pdf
- DECC. 2012a. *Energy Flow Chart 2012*. Available at: https://www.gov.uk/government/uploads/system/uploads/attachment_data/file/224122/energy_flow_chart_2012.PDF
- DECC. 2012b. *The future of heating: A strategic framework for low carbon heat*. Available at: <https://www.gov.uk/government/publications/the-future-of-heating-a-strategic-framework-for-low-carbon-heat>

DECC. 2013a. *The annual Energy Brief 2013*. Available at:
https://www.gov.uk/government/uploads/system/uploads/attachment_data/file/224130/uk_energy_in_brief_2013.PDF

DECC. 2013b. *The Future of Heating: Meeting the challenge*. Available at:
https://www.gov.uk/government/uploads/system/uploads/attachment_data/file/190149/16_04-DECC-The_Future_of_Heating_Accessible-10.pdf

DECC. 2014. *Overview of grant funding and guidance available to local authorities developing heat networks*. Available at
https://www.gov.uk/government/uploads/system/uploads/attachment_data/file/375623/HN_DU_overview_round4_Oct2014_PRINT_VERSION.pdf

DETR. 2000. *Climate Change The UK Programme* . Available at: <http://www.cne-siar.gov.uk/emergencyplanning/documents/Climate%20Change%20-%20UK%20Programme.pdf>

DTi. 2007. *Meeting the Energy Challenge*. Available at:
<http://webarchive.nationalarchives.gov.uk/20090609003228/http://www.berr.gov.uk/files/file39387.pdf>

EC.2013 *High-level Round Table on the future of the European Steel Industry Recommendations*. Available at:
<http://ec.europa.eu/DocsRoom/documents/11915/attachments/1/translations/en/renditions/native>

EC. 2001. *BREF: Reference Document on Best Available Techniques in the Ferrous Metals Processing Industry*. Available at:
http://eippcb.jrc.ec.europa.eu/reference/BREF/fmp_bref_1201.pdf

EC. 2009. *BREF Energy Efficiency*. Available at:
http://eippcb.jrc.ec.europa.eu/reference/BREF/ENE_Adopted_02-2009.pdf

EC. 2010. *The European Strategic Energy Technology Plan SET-Plan Towards a low-carbon future* . Available at: <http://ec.europa.eu/energy/en/topics/technology-and-innovation/strategic-energy-technology-plan>

EC. 2011a. *A Roadmap for moving to a competitive low carbon economy in 2050*. European Commission. Available at: <http://eur-lex.europa.eu/legal-content/EN/TXT/?uri=CELEX:52011DC0112>

EC. 2011b. *Roadmap for moving to a competitive low carbon economy in 2050* .<http://eur-lex.europa.eu/legal-content/EN/TXT/?uri=CELEX:52011DC0112>

EC. 2012. *Prospective Scenarios on Energy Efficiency and CO2 Emissions in the EU Iron & Steel Industry*.
<http://publications.jrc.ec.europa.eu/repository/bitstream/111111111/26669/1/ldna25543enn.pdf>

- EC. 2013a. *A 2030 framework for climate and energy policies* . Available at: <http://eur-lex.europa.eu/legal-content/EN/TXT/?uri=CELEX:52011DC0112>
- EC. 2013b. *Best Available Techniques (BAT) Reference Document for Iron and Steel Production*. Available at:
http://eippcb.jrc.ec.europa.eu/reference/BREF/IS_Adopted_03_2012.pdf
- EC. 2013c. *Ensuring a future for steel in Europe*. Available at:
http://ec.europa.eu/enterprise/magazine/articles/sustainable-industry-innovation/article_11094_en.htm
- EC. 2014. *Taking stock of the Europe 2020 strategy for smart, sustainable and inclusive growth*. Available at:
http://ec.europa.eu/clima/policies/eccp/docs/second_eccp_report_en.pdf
- EEF. 2014a. *About the Industry web page*. Available at:
<http://www.eef.org.uk/uksteel/About-the-industry/default.htm>
- EEF. 2014. *Key Stats 2014*. Available at: <http://www.eef.org.uk/uksteel/About-the-industry/Steel-facts/default.htm>
- EEF. 2014b. *Production of Molten Steel*. Available at:
<http://www.eef.org.uk/uksteel/About-the-industry/How-steel-is-made/default.htm>
- EEF. 2014c. *Steel Casting and Hot Rolling*. Available at:
<http://www.eef.org.uk/uksteel/About-the-industry/How-steel-is-made/default.htm>
- EEF. 2014d. *World Crude Steel Production*. Available at
<http://www.eef.org.uk/uksteel/About-the-industry/How-steel-is-made/default.htm>
- Energy, Element. 2014a. *The potential for recovering and using surplus heat from industry*
Appendix for Final Report
- Engineering, G. G. A. H. 2014. *Iron and Steel Industry - Waste Heat Recovery* [Online]. Available at: <http://www.globalgeothermal.com/IronSteelIndustry.aspx> [Accessed.
- EPA. 2010. *Energy Efficiency Improvement and Cost Saving Opportunities for the U.S. Iron and Steel Industry* An ENERGY STAR® Guide for Energy and Plant Managers.
- EPA. 2012. *Emerging Technologies for reducing Green House Gas Emissions from the Iron and Steel Industry*.
- EPA, U. 2014. *Global GHG Emissions by Source* [Online]. Available at:
<http://www.epa.gov/climatechange/ghgemissions/global.html> [Accessed.
- EPSRC. 2009. Evaluation of a large energy intensive site to determine if centralised electricity generation and steam distribution is preferable to local generation.
- ERP. 2011. *Industrial Energy Efficiency Key Messages*. <http://erpuk.org/wp-content/uploads/2014/12/ERP-Industrial-Energy-Efficiency-Key-Messages-FINAL.pdf>

- Eurofer. 2012. *EU steel market situation and outlook Key challenges*.
<http://www.oecd.org/sti/ind/50494789.pdf>
- Fairbrother, P. et al. 2004. *The Internationalisation of the World Steel Industry*.
<http://www.cardiff.ac.uk/socsi/resources/wrkpaper-53.pdf>
- Flite. 2012. Personal Communication regarding surface roughness - email dated.
- Forni, D. et al. *Heat recovery for Electricity Generation in Industry*.
<http://www.hreii.eu/public/2012%20ECEE.pdf>
- FT. Financial Times. 2014. *Is there a future for UK steel?*
<https://www.youtube.com/watch?v=DaYS1mKNo64&list=UUoUxsWakJucWg46KW5RsvPw>
- Futures, C. f. l. c. 2011. *Technology Innovation for Energy Intensive Industry in the United Kingdom*.
http://www.lowcarbonfutures.org/sites/default/files/EIITechnologyInnovation_1313051712.pdf
- Gent, P. 2010. *Industrial Waste heat energy recovery systems – technology overview and approaches for selection of system*.
http://www.esru.strath.ac.uk/Documents/MSc_2010/Gent.pdf
- Giles, A. 2011. *11 bar Steam Main Thermal Imaging Survey*. Cardiff University.
- GmbH, S. V. M. T. 2014. *Efficiency up and costs down produce metals with less energy input*. <http://www.abmbrasil.com.br/cim/download/gerhard.pdf>
- Gopalakrishnan, B. et al. 2007. *Modelling steam-based energy supply chain in an integrated steel manufacturing facility: a simulation-based approach*. *Industrial and Systems. Engineering* Vol 2 No1 2007.
- GOV, U. 2008. *The Climate Change Act*.
http://www.legislation.gov.uk/ukpga/2008/27/pdfs/ukpga_20080027_en.pdf
- GOV.UK. 2010. *2050 Pathway Analysis* [Online]. Available at:
https://www.gov.uk/government/uploads/system/uploads/attachment_data/file/42562/216-2050-pathways-analysis-report.pdf [Accessed.
- GOV.UK. 2011. *Carbon Plan*.
https://www.gov.uk/government/uploads/system/uploads/attachment_data/file/47621/1358-the-carbon-plan.pdf
- GOV.UK. 2014. *Energy-intensive industries: compensation for indirect costs of energy and climate change policies*. <https://www.gov.uk/guidance/energy-intensive-industries-compensation-for-carbon-leakage>
- GOV.UK. Accessed 2015. *Enhanced Capital allowance*.
<https://www.gov.uk/government/policies/energy-demand-reduction-in-industry-business-and-the-public-sector>

Group, I. a. S. 1961. *The effect of the various steelmaking processes on the energy balances of integrated iron- and steelworks: Report of the 43rd meeting of the Iron and Steel Engineers Group.*

Hemmling, P. 2012. *Eco Plants: how to make the plants of today comply with the requirements of tomorrow* [Online]. SMS Siemag AG. Available at: https://www.sms-siemag.com/symposium/india/html/doc/16_ECOPLANTS_SYMPOSIUM_INDIA_2012.PDF [Accessed].

Holman, J. 2011. *Perspective: Waste Heat to Power — Still Waiting for a Breakthrough.* IDC Energy Insights, Renewable Energy Strategies

Houghton, S. 2012. Heat Loss From Insulated and Uninsulated Pipes. Tata Steel Internal Report.

ICF. 2012. *An international comparison of energy and climate change tax.* https://www.gov.uk/government/uploads/system/uploads/attachment_data/file/31768/12-527-international-policies-impacting-energy-intensive-industries.pdf

idlechik. 1960. *Handbook of Hydraulic Resistance. Coefficients of Local Resistance and of Friction.* Published for the US Atomic Energy Commission and National Science Foundation, Washington DC

IEA. 1994. *The History of the International Energy Association 1974 to 1994.* <http://www.iea.org/media/2ieahistory.pdf>

IEA. 2007. *Tracking Industrial Energy Efficiency and CO2 Emissions.* http://www.iea.org/publications/freepublications/publication/tracking_emissions.pdf

IEA. 2014. *International Energy Association - About us.* <http://www.iea.org/aboutus/>

IEA-COAL. 2012. *CO2 abatement in the iron and steel industry.* <http://www.iea-coal.org/documents/82861/8363/CO2-abatement-in-the-iron-and-steel-industry,-CCC/193>

IFC and IIP. *Heat recovery for electricity generation in industry.* <http://www.ifc.org/wps/wcm/connect/a87be50044581e9889678dc66d9c728b/IFC+Waste+Heat+Recovery+Report.pdf?MOD=AJPERES>

IISI. 1998. *Energy Use in the Steel Industry.*

Isaksson, J. et al. 2011. *Possibilities to implement pinch analysis in the steel industry – a case study at SSAB EMEA in Luleå.* World Renewable Energy Conference 2011. http://www.ep.liu.se/ecp/057/vol7/024/ecp57vol7_024.pdf

ISSB. 2014. *EU27 Crude Steel Production.* <http://www.issb.co.uk/eu28.html>

J.S.Jeans. 1881. *On the consumption of fuel in the iron and steel making manufacture.* Journal of the Iron and Steel Institute 3: pp. 128-179.

Kasalo, J. 2010. *Utilisation of evaporation waste gas cooling systems to counteract rising energy cost.* AISTech Iron and Steel Technology Conference Proceedings 2010.

- Kemp, I. C. *Pinch Analysis and Process Integration*.
http://www.petronet.ir/documents/10180/2323242/Pinch_Analysis_and_Process_Integration
- Larsson, M. 2004. *Process Integration in the Steel Industry- Possibilities to Analyse Energy Use and Environmental Impacts for an Integrated Steel Mill*.
<https://pure.ltu.se/portal/files/77187/LTU-DT-0463-SE.pdf>
- Limited, D. I. 2014. *Understanding Pressure Sensor Accuracy* [Online]. Available at:
<http://www.dwyer-inst.co.uk/articles/industry/powderbulk/understanding-pressure-sensor-accuracy/understanding-pressure-sensor-accuracy.cfm> [Accessed: September].
- LISP. 2014. *Low Impact Steel Project* [Online]. Available at:
<http://www.globalccsinstitute.com/project/low-impact-steel-project-formerly-ulcos-blast-furnace> [Accessed].
- Liu, Y. et al. 2014. *Energy and exergy analysis for waste heat cascade utilization in sinter cooling bed*. *Energy* 67 (2014) 370e380.
- Lyle, O. 1947. *The Efficient use of Steam*. Book, Published by HMSO
- Manchester, University 2010a. *Addressing the barriers to utilisation of low grade heat from the thermal process industries*. http://research.ncl.ac.uk/program/components/pdfs/EPSRC_Thermal_Management_Tyndall_Progress_Report__23June2010.pdf
- Manchester, University 2010b. *Addressing the barriers to utilisation of low grade heat from the thermal process industries*. Tyndall Centre for Climate Change Research:
- Manchester University 2010. *Resident Opinion on the Prospective Use of Waste Process Heat for District Heating in Neath Port Talbot, South Wales Results Summary*.
- McKenna, R. C. 2009a. *Industrial energy efficiency Interdisciplinary perspectives on the thermodynamic, technical and economic constraints*.
http://opus.bath.ac.uk/18066/1/Industrial_Energy_Efficiency_McKenna_030809.pdf
- Miller, D. S. 1978. *Internal Flow Systems*. 2nd addition, ISBN 0-947711-77-5
- Moody, L. F. 1944. *Friction Factors for Pipe Flow*. A.S.M.E.
- NI, F. S. 2014. *Fluidflow 3 Website* [Online]. Available at: <http://www.fluidflowinfo.com/> [Accessed].
- Newcastle University. National sources of low grade heat available from the process industry Progress Report (Feb. 2011).
- Norman, J. B. 2013. *Industrial Energy Use and Improvement Potential*. Thesis University of Bath.
http://opus.bath.ac.uk/36458/1/UnivBath_PhD_2013_J_Norman.pdf

NPTCBC. 2013. *Renewable & Low Carbon Energy Topic Paper*.
http://www.npt.gov.uk/PDF/ldp_deposit_renewable_low_carbon_energy_topic_paper_august_2013.pdf

nrg4SD. 2011. *The UNFCCC and the Kyoto Protocol*.
http://nrg4sd.org/sites/default/files/default/files/content/public/29-climatechange/background/general/rough_guide_unfccc_and_kyoto_protocol_09052011.pdf

OECD. 2013. *OECD Work on Climate Change 2013-14*.
http://www.oecd.org/env/cc/Work-on-Climate-Change-2013-14_web.pdf

Oschatz. 2012. *Plant Engineering and Waste Heat Systems for the Iron and Steel Industry*.
http://www.oschatz.com/fileadmin/user_upload/Dokumente/Broschueren_PDFs/Oschatz_Stahl_Eisen_E_web.pdf

Parry, S. 2011. *History of the Steel Industry in the Port Talbot Area 1900-1988* (PhD Thesis). <http://etheses.whiterose.ac.uk/2591/1/parrystephen.pdf>

Patsos, A. 2012. *Towards a Low-Carbon Future in the UK: The Importance of Waste Heat Recovery in the Process Industries*. EPSRC PROTEM network.

Patsos, A. and Mullan, H. 2011. *Identification and classification of waste heat streams and their exergy component review of enabling technologies on an integrated steelworks*. EECR 2011.

Paul, Z. H. 2011. *Energy consumption and CO₂ emissions benchmarking and modelling in Port Kembla Steelworks*. Chemica 2011.

Peter, P. and Jim, W. 2012. *UK Energy Policy 1980-2010, A history and lessons to be learnt*. Parliamentary Group for Energy Studies.

Planning, N. I. 2014. *Internal Power Generation Enhancement for Port Talbot Steelworks*. Website Accessed October 2014.

Protheroe-Jones, R. 1995. *Welsh Steel Book*.

Purwanto, H. A., Tomohiro. 2006. *Hydrogen production from biogas using hot slag*. International Journal of Hydrogen Energy Volume 31, Issue 4, March 2006, Pages 491–495.

Rivers, I. 2008. *Fast Facts on International Targets: Sign of Hope, or Just Hot Air?* [Online]. Available at: <http://www.internationalrivers.org/blogs/246/fast-facts-on-international-targets-sign-of-hope-or-just-hot-air> [Accessed].

Rusche, T. M. 2010. *The European climate change program: An evaluation of stakeholder involvement and policy achievements* Energy Policy: Elsevier.

Sarco, S. 2001. *Spirax Sarco engineered system saves £150,000 per year for Corus*.
http://www.spiraxsarco.com/global/ie/Industries/Documents/Spirax_Sarco_engineered_system_saves_£150,000_per_year_for_Corus.pdf

Sarco, S. 2012. Port Talbot Works Steam System Efficiency Report.

Sarco, S. 2014. *Schedule 40 pipework dimensions* [Online]. Available at: http://www.snapfour.com/pdf/Table_38-39.pdf [Accessed].

Sarco, S 2015 Temperature Enthalpy Diagram. Available at: <http://www.spiraxsarco.com/Resources/Pages/Steam-Engineering-Tutorials/steam-engineering-principles-and-heat-transfer/entropy-a-basic-understanding.aspx>

Schultz, R. R. 2014. Modelling the Seattle Steam Co Distribution steam co Distribution System with RELAP5-3D. <http://www4vip.inl.gov/relap5/rius/jackson/schultz.pdf>

Siemens. 2014. *Solutions to maximize energy recovery from sinter coolers Why Waste Energy?* http://www.industry.siemens.com/datapool/industry/industrysolutions/metals/magazines/01_2014/Articles/Why-Waste-Energy-Metals-Magazine.pdf

Tata Steel, 2011. *Port Talbot Visitor Guide*. Issued by Tata Steel

Tata Steel, 2013. *Scoping Report TATA Steel UK Limited: Internal Power Generation Enhancement for Port Talbot Steelworks*.

Tata Steel, 2014. *Energy Optimisation Certificate*. Internal Certificate Issued by Tata Steel 2014

Swagelok. 2014. *Swagelok Energy Advisors : Best Practices*. <http://www.swagelokenergy.com/practices/practices.aspx>

Trotman, G. a. 1984. *Energy 2000–2020: World prospects and regional stresses*: coordinated and edited by J.R. Frisch for World Energy Conference Conservation Commission Graham and Trotman, London, 1983, 259 pp [Gerald Leach]. *Energy Policy*: p. 259.

Turner, C. W. and Doty, S. 2006. *Energy Management Handbook*. http://www.serviciocale.md/public/files/Energy_Management_Handbook.pdf

U.N. 1972. *Declaration of the United Nations Conference on the Human Environment*. United Nations Conference, 21st plenary meeting, chapter 11: United Nations.

UN. 1992. *United Nations Framework Convention on Climate Change*. United Nations. http://unfccc.int/files/essential_background/background_publications_htmlpdf/application/pdf/conveng.pdf

UN. 1995. *COPI*. Berlin list of Documents web page. <http://unfccc.int/cop4/resource/cop1.html>

UN. 2012. *World Statistics Pocketbook* 2011 http://www.un.org/ru/publications/pdfs/world%20statistics%20pocketbook%202011_en.pdf

- UNEP. 2006. *Waste Heat Recovery*.
http://www.energyefficiencyasia.org/docs/ee_modules/Chapter-Waste%20Heat%20Recovery.pdf
- USDoE. 2008. *Waste Heat Recovery: Technologies and Opportunities in US Industry*.
http://www1.eere.energy.gov/manufacturing/intensiveprocesses/pdfs/waste_heat_recovery.pdf
- USDoE. 2012. *Improving Steam System Performance: A Sourcebook for Industry*.
https://www1.eere.energy.gov/manufacturing/tech_assistance/pdfs/steamsourcebook.pdf
- USDoE. 2014. *Steam Systems tool suit* [Online]. Available at:
http://www1.eere.energy.gov/manufacturing/tech_assistance/software_ssat.html [Accessed.
- USEPA. 1998. *Wise Rules for Industrial Efficiency*.
<http://nepis.epa.gov/Exe/ZyNET.exe/P1005GD9.txt?ZyActionD=ZyDocument&Client=EP A&Index=1995%20Thru%201999&Docs=&Query=&Time=&EndTime=&SearchMethod=1&TocRestrict=n&Toc=&TocEntry=&QField=&QFieldYear=&QFieldMonth=&QFieldDay=&UseQField=&IntQFieldOp=0&ExtQFieldOp=0&XmlQuery=&File=D%3A%5CZY FILES%5CINDEX%20DATA%5C95THRU99%5CTXT%5C00000024%5CP1005GD9.txt&User=ANONYMOUS&Password=anonymous&SortMethod=h%7C-&MaximumDocuments=1&FuzzyDegree=0&ImageQuality=r75g8/r75g8/x150y150g16/i425&Display=p%7Cf&DefSeekPage=x&SearchBack=ZyActionL&Back=ZyActionS&BackDesc=Results%20page&MaximumPages=1&ZyEntry=20>
- Wall, G. 1986. *Exergy Flows in Industrial Processes*. Energy Vol. 13, No. 2, pp. 197-208.
<http://exergy.se/ftp/exindproc.pdf>
- WEC. 1989. *Global Energy Perspectives 2000 - 2020* [Online]. Available at:
<http://www.worldenergy.org/work-programme/strategic-insight/global-energy-scenarios/wecs-global-expertise-in-scenario-design/> [Accessed.
- WEC. 2011. *Global Transport Scenarios 2050*.
http://www.worldenergy.org/documents/wec_transport_scenarios_2050.pdf
- WEC. 2012. *World Energy Trilemma - time to get real*.
http://www.worldenergy.org/documents/world_energy_trilemma_2012__executive_summary_final.pdf
- WEC. 2014b. WEC Web News, *WEC Colombia hosts discussion on critical energy issues*.
<http://www.worldenergy.org/news-and-media/local-news/wec-colombia-hosts-discussion-on-critical-energy-issues/>
- Wood, D. J. 2010. *Pipe2000 Campus acilities Modeling*.
http://kypipe.com/new_stuff/campusmodeling.pptx
- WSA. 2012. *Sustainable Steel At the core of a green economy*.
<http://www.worldsteel.org/dms/internetDocumentList/bookshop/Sustainable-steel-at-the-core-of-a-green-economy/document/Sustainable-steel-at-the-core-of-a-green-economy.pdf>

WSA. 2013a. *Steel's contribution to a low carbon future worldsteel position paper*. <http://www.worldsteel.org/dms/internetDocumentList/press-release-downloads/2013/Steel-s-Contribution-to-a-Low-Carbon-Future/document/Steel's%20Contribution%20to%20a%20Low%20Carbon%20Future.pdf>

Williams C, 2012 Internal TataSteel Presentation *Waste Heat Recovery and steam distribution strategy 2012*

Williams C, Anthony Griffiths, Tim O'Doherty and Anthony Giles, *Utilising Waste Heat for Steam Generation and CO₂ Reduction*, ACEEE Summer Study Conference Proceedings 2013. http://aceee.org/files/proceedings/2013/data/papers/3_009.pdf

WSA. 2013b. *World Steel in Figures 2013*. <https://www.worldsteel.org/dms/internetDocumentList/bookshop/Word-Steel-in-Figures-2013/document/World%20Steel%20in%20Figures%202013.pdf>

WSA. 2014. *Key Facts about the world steel industry*. <http://www.worldsteel.org/media-centre/key-facts.html>

Zafer Utlü, U. P. 2013. *Investigation of the potential of thermophotovoltaic heat recovery for the Turkish industrial sector*. Energy Conversion and Management Volume 74, October 2013, Pages 308–322.

Zhang, H. et al. 2013a. *A review of waste heat recovery technologies towards molten slag in steel industry*. Applied Energy 112: pp. 956-966.