

Non-Semisimple Planar Algebras from $\bar{U}_q(\mathfrak{sl}_2)$.

Stephen Moore

A thesis presented for the degree of
Doctor of Philosophy

2016

Summary

We construct examples of non-semisimple tensor categories using planar algebras, with our main focus being on a construction from the restricted quantum group $\bar{U}_q(\mathfrak{sl}_2)$. We describe the generators and prove a number of relations for the $\bar{U}_q(\mathfrak{sl}_2)$ planar algebra, as well as describing diagrammatically various homomorphisms between modules, and conjecture a formula for projections onto indecomposable modules.

DECLARATION

This work has not been submitted in substance for any other degree or award at this or any other university or place of learning, nor is being submitted concurrently in candidature for any degree or other award.

Signed (candidate) Date

STATEMENT 1

This thesis is being submitted in partial fulfillment of the requirements for the degree of PhD.

Signed (candidate) Date

STATEMENT 2

This thesis is the result of my own independent work/investigation, except where otherwise stated. Other sources are acknowledged by explicit references. The views expressed are my own.

Signed (candidate) Date

STATEMENT 3

I hereby give consent for my thesis, if accepted, to be available online in the University's Open Access repository and for inter-library loan, and for the title and summary to be made available to outside organisations.

Signed (candidate) Date

STATEMENT 4: PREVIOUSLY APPROVED BAR ON ACCESS

I hereby give consent for my thesis, if accepted, to be available online in the Universitys Open Access repository and for inter-library loans after expiry of a bar on access previously approved by the Academic Standards & Quality Committee.

Signed (candidate) Date

Acknowledgements

Thanks to my family for supporting me throughout this, and to David for taking a chance on me, this wouldn't have been possible without any of you.

Thanks also to the various people in the Cardiff maths department who have helped me over the years.

Contents

1	Introduction	9
2	Background	11
2.1	Basics of Von Neumann Algebras	11
2.2	Basics of Subfactors	15
2.3	The Standard Invariant	19
2.4	Planar Algebras	19
2.5	Tensor Categories	24
2.6	Quantum Groups	27
3	\mathbb{K}-Planar Algebras	30
3.1	A Generalised Definition of Planar Algebras	30
3.2	Bipartite Graph Planar Algebras	33
3.3	Temperley-Lieb Algebras	38
3.4	Temperley-Lieb Category	42
3.4.1	The Semion Construction	44
3.4.2	The Ising Construction	48
3.4.3	The Fibonacci and Yang-Lee Construction	60
4	The Quantum Group $\bar{U}_q(\mathfrak{sl}_2)$	68
4.1	$\bar{U}_q(\mathfrak{sl}_2)$	68
4.2	Tensor Decomposition of Modules	70
4.3	Multiplicity of Modules and dimension of $End((\mathcal{X}_2^+)^{\otimes n})$	74
4.4	$\bar{U}_q(\mathfrak{sl}_2)$ Invariant Maps between Modules.	85
4.4.1	Projective module Endomorphisms	85
4.4.2	Homomorphisms between projective and simple modules.	87
4.4.3	Homomorphisms between projective modules	91

5	The $\bar{U}_q(\mathfrak{sl}_2)$ Planar Algebra.	93
5.1	The Temperley-Lieb Algebra	94
5.2	The $\bar{U}_q(\mathfrak{sl}_2)$ Planar Algebra	95
5.3	The Generators α and β	102
5.3.1	Proof of the commutivity of α and β with the $\bar{U}_q(\mathfrak{sl}_2)$ action.	102
5.3.2	Proof that $Im \alpha \simeq Im \beta \simeq \mathcal{X}_p^-$	104
5.3.3	Composition of α and β	106
5.3.4	Proof that $\alpha_i \alpha_j = \beta_i \beta_j = 0$ if $ i - j < p$	108
5.3.5	Proof that $\alpha_i \alpha_{i+p} = \alpha_{i+p} \alpha_i$ and $\beta_i \beta_{i+p} = \beta_{i+p} \beta_i$	109
5.3.6	Proof that $\alpha\beta + \beta\alpha = \gamma \mathfrak{f}_{2p-1}$	115
5.4	Relations between α, β and the Temperley-Lieb algebra.	116
5.4.1	Proof of capping and cupping relations.	116
5.4.2	Relations from the Rotation tangle	122
6	Projections and Homomorphisms on Indecomposable Modules.	133
6.1	Summary of Projections and Morphisms.	133
6.2	Formula for maps on \mathcal{P}_i^+	137
6.2.1	General Formula for the map $\theta : X^{\otimes 2p-i-1} \rightarrow \mathcal{P}_i^+$	137
6.2.2	General Formula for the map $\Gamma : \mathcal{P}_i^+ \rightarrow X^{\otimes 2p-i-1}$	139
6.2.3	General Formula for the Second Endomorphism on \mathcal{P}_i^+	141
6.3	The Homomorphisms $\mathcal{P}_i^+ \rightarrow \mathcal{X}_i^+$	141
6.4	The Homomorphisms $\mathcal{X}_i^+ \rightarrow \mathcal{P}_i^+$	144
6.5	The Second Endomorphisms $\mathcal{P}_i^+ \xrightarrow{\varepsilon} \mathcal{P}_i^+$	147
6.6	The Partial Trace of $\alpha\beta$ and $\beta\alpha$	149
6.6.1	The partial trace of $\beta\alpha$	150
6.6.2	The partial trace of $\alpha\beta$	151
6.7	The homomorphisms $\mathcal{P}_i^\pm \rightarrow \mathcal{P}_{p-i}^\mp$	154
6.8	A Conjecture of the formula for the indecomposable projections:	158
	Appendix A Combinatorial Identities	166
A.1	Quantum Integers	166
A.2	Relations on $(\mathcal{X}_2^+)^{\otimes z}$	167
	Appendix B The Jones-Wenzl Projections	170

Appendix C An alternate proof of the diagrammatic formula for the Second

Endomorphism on \mathcal{P}_i^+	175
C.1 The partial trace of the second endomorphism	176
C.2 The second endomorphism on \mathcal{P}_1^+	179

Chapter 1

Introduction

Planar algebras are a type of graded diagrammatic algebra introduced in relation to subfactors, and which have close relations to rigid tensor categories. However the majority of current examples of planar algebras, such as the constructions in [2, 48], are subfactor planar algebras, which are positive-definite, unitary and semisimple. The aim of this thesis is to construct examples of non-semisimple and non-unitary tensor categories using planar algebras, with our main focus being on a construction coming from the representation theory of the restricted quantum group $\bar{U}_q(\mathfrak{sl}_2)$ [18].

We start by reviewing subfactors and how they lead to planar algebras, then briefly discuss tensor and fusion categories, and quantum groups, and how they lead to examples of planar algebras.

In chapter 3 we give a general definition of planar algebras, and introduce two standard examples, the Temperley-Lieb algebra, and the bipartite graph planar algebra. We then discuss a categorical variation of the Temperley-Lieb algebra, and use it to construct some basic examples of fusion categories, with our focus being on the Semion, Ising, and Fibonacci/Yang-Lee fusion rules.

Chapters 4, 5, and 6, are dedicated to the construction of a planar algebra from the restricted quantum group $\bar{U}_q(\mathfrak{sl}_2)$. It was conjectured in [22] that the representation category of $\bar{U}_q(\mathfrak{sl}_2)$ is equivalent to the representation category of the $W(p)$ logarithmic conformal field theory for $q = e^{i\pi/p}$, and proven for the case $p = 2$. An equivalence as abelian categories was confirmed in [52], however [42] showed that for $p > 2$, there is a $\bar{U}_q(\mathfrak{sl}_2)$ module whose tensor product doesn't commute, and hence can't be braided, and so the categories aren't equivalent as tensor categories. However our construction only

considers a subcategory of $\bar{U}_q(\mathfrak{sl}_2)$ modules where this module doesn't appear. In chapter 4 we introduce $\bar{U}_q(\mathfrak{sl}_2)$ and its representation theory, as well as discussing the dimensions of our planar algebra.

Chapter 5 is focused on our $\bar{U}_q(\mathfrak{sl}_2)$ planar algebra construction. The planar algebra construction is a diagrammatic description of $End_{\bar{U}_q(\mathfrak{sl}_2)}((\mathcal{X}_2^+)^{\otimes n})$, where \mathcal{X}_2^+ is the two-dimensional irreducible $\bar{U}_q(\mathfrak{sl}_2)$ module. This forms an algebra for each n . For $n < 2p - 1$, this algebra is the Temperley-Lieb algebra, $TL_n(\delta)$, with $\delta = q + q^{-1}$, and for $n \geq 2p - 1$, is the algebra generated by $TL_n(\delta)$ and two extra generators, α and β . These generators were first introduced in [25], however we give our own definition for them, and prove a number of relations on them.

Chapter 6 is focused on the indecomposable modules that appear in the decomposition of $(\mathcal{X}_2^+)^{\otimes n}$, and consists of diagrammatic descriptions of various maps between these modules, including the second (non-identity) endomorphism on indecomposable projective modules. We conclude with a conjectured formula for the projection onto these indecomposable modules, as a generalization of the Jones-Wenzl projections. An alternative formula for these projections was given independently in [28].

Chapter 2

Background

2.1 Basics of Von Neumann Algebras

Let $\mathcal{B}(\mathcal{H})$ be the set of bounded operators on a Hilbert space \mathcal{H} . There is a norm on the operators given by the Hilbert space inner product;

$$\|A\| := \sup\{\sqrt{\langle Ax, Ax \rangle}, x \in \mathcal{H} : \|x\| \leq 1\}$$

and an involution map, $*$, such that $\langle Ax, y \rangle := \langle x, A^*y \rangle$. An operator is called *self-adjoint* if $A = A^*$, and *positive* if $\langle Ax, x \rangle \geq 0$ for all $x \in \mathcal{H}$. A positive operator is necessarily self-adjoint. If $AA^* = A^*A$, the operator is said to be *normal*. If $A^*A = 1$, the operator is called an *isometry*, and is *unitary* if $AA^* = 1$ also holds. An operator is called a *projection* if $A = A^* = A^2$. If A^*A is a projection, then A is called a *partial isometry*. A set $S \subseteq \mathcal{B}(\mathcal{H})$ is said to be self-adjoint if for all $A \in S, A^* \in S$.

A *C*-algebra* \mathcal{A} is an involutive normed Banach algebra such that $\|x^*x\| = \|x\|^2$ for all $x \in \mathcal{A}$. Every C*-algebra is isomorphic to a norm-closed subalgebra of $\mathcal{B}(\mathcal{H})$, for some Hilbert space \mathcal{H} . The *commutant* of a set S is the set $S' := \{x \in \mathcal{B}(\mathcal{H}) : sx = xs \text{ for all } s \in S\}$. There are various topologies possible on $\mathcal{B}(\mathcal{H})$. Firstly there is the *norm topology*, with open balls given by the norm. Hence for a sequence of operators A_n , $A_n \rightarrow A$ if $\|A_n - A\| \rightarrow 0$. The *strong operator topology* is defined such that $A_n \rightarrow A$ if $\|A_n\eta - A\eta\| \rightarrow 0$ for all $\eta \in \mathcal{H}$. Similarly the *weak operator topology* is defined such that $A_n \rightarrow A$ if $\langle A_n\eta, \nu \rangle \rightarrow 0$ for all $\eta, \nu \in \mathcal{H}$. In order of strength, we have; weak < strong < norm [55].

A *von Neumann Algebra* is a self-adjoint subalgebra of $\mathcal{B}(\mathcal{H})$, containing $1 \in \mathcal{B}(\mathcal{H})$,

that is closed in the weak operator topology [19]. The fundamental result of von Neumann Algebras is von Neumann's *bicommutant theorem* [4]: For a unital self-adjoint subalgebra \mathcal{A} of $\mathcal{B}(\mathcal{H})$, the following are equivalent:

1. \mathcal{A} is closed in the weak operator topology
2. \mathcal{A} is closed in the strong operator topology
3. $\mathcal{A} = \mathcal{A}''$

From this we see that we can easily form many examples of von Neumann algebras from a set S of operators by taking $(S \cup S^)''$. Note that $(S \cup S^)' = (S \cup S^)'''$ is also a von Neumann algebra. Indeed von Neumann algebras naturally come in pairs, \mathcal{A} and \mathcal{A}' . A von Neumann algebra \mathcal{A} with trivial centre, i.e. $\mathcal{A} \cap \mathcal{A}' = \mathbb{C}1$, is called a *factor*. Every von Neumann algebra can be viewed as either a direct sum or direct integral of factors [4]. This leads to the obvious question "Is there a classification of factors?". This was answered by Murray and von Neumann who classified factors in terms of their projections [50]. For two projections p, q in a von Neumann algebra \mathcal{A} , we say $p \leq q$ if $q - p$ is positive. This provides a partial order on the projections in \mathcal{A} . Another partial order is given if there is a partial isometry $u \in \mathcal{A}$ such that $uu^* = p$ and $u^*u \leq q$ which we denote as $p \lesssim q$. There is an equivalence, $p \sim q$ if there is a partial isometry $u \in \mathcal{A}$ such that $uu^* = p$ and $u^*u = q$. A projection p is called *infinite* if $q \sim p$ for some $q \leq p$, $p \neq q$, otherwise p is called *finite*. A von Neumann algebra is called *finite* if its identity is finite, and is called *purely infinite* if it has no finite projections other than 0. A factor is called *infinite* if its identity is infinite. A non-zero projection p is called *minimal* if $q \leq p \Rightarrow q = 0$ or $q = p$. We have the following results on projections [36]:

- If $\dim \mathcal{H} = \infty$ then $\mathcal{B}(\mathcal{H})$ is infinite
- A factor with a unique trace is finite
- Every projection in a finite von Neumann algebra is finite. This comes from the stronger result that if $p \leq q$ and q is finite then p is finite
- If \mathcal{A} is any von Neumann algebra then 1 is an infinite projection in $\mathcal{A} \otimes \mathcal{B}(\mathcal{H})$ if $\dim \mathcal{H} = \infty$
- If \mathcal{A} is a factor and p, q are projections in \mathcal{A} then either $p \lesssim q$ or $q \lesssim p$
- p is minimal in \mathcal{A} if and only if $p\mathcal{A}p = \mathbb{C}p$

A *trace* on a von Neumann algebra \mathcal{A} is a linear function $tr : \mathcal{A} \rightarrow \mathbb{C}$ satisfying:

- $tr(ab) = tr(ba)$
- $tr(a^*a) \geq 0$
- tr is ultraweakly continuous
- The trace is called *faithful* if $tr(x^*x) = 0 \Rightarrow x = 0$
- The trace is said to be *normalized* if $tr(1) = 1$.

The *ultraweak topology* on $\mathcal{B}(\mathcal{H})$ is given by the basic neighbourhoods about a ;

$\{b : \sum_{i=1}^{\infty} |\langle (a-b)\eta_i, \nu_i \rangle| < \epsilon\}$ for any $\epsilon > 0$ and sequences $(\eta_i), (\nu_i) \in l^2(\mathcal{H})$ with $\sum_{i=1}^{\infty} \|\eta_i\|^2 + \|\nu_i\|^2 < \infty$. Similarly the *ultrastrong topology* is given by basic neighbourhoods $\{b : \sum_{i=1}^{\infty} \|(a-b)\eta_i\|^2 < \epsilon\}$. These coincide with the weak and strong topologies respectively on norm bounded subsets of $\mathcal{B}(\mathcal{H})$. The ultraweak and ultrastrong topologies on $\mathcal{B}(\mathcal{H})$ can be viewed as the restriction of the weak and strong topologies on $\mathcal{B}(\mathcal{H} \otimes l^2(\mathbb{N}))$ to $\mathcal{B}(\mathcal{H}) \otimes \mathbf{1}$. We can now give a **classification of factors**: A factor is said to be:

- *Type I* if it has a minimal non-zero projection
- *Type II* if it has non-zero finite projections, but no minimal non-zero projection
- *Type III* if it contains no non-zero finite projection

Every type I factor is isomorphic to $\mathcal{B}(\mathcal{H})$. It is said to be type I_n when $dim(\mathcal{H}) = n$ where n is allowed to be infinite. Type II factors can be either II_1 or II_{∞} factors. Type II_1 factors have a unique faithful trace. Type II_{∞} factors are of the form $\mathcal{A} \otimes \mathcal{B}(\mathcal{H})$ where \mathcal{A} is a II_1 factor and \mathcal{H} is infinite dimensional. If \mathcal{A} is a II_1 factor on \mathcal{H} , and $p \in \mathcal{A}$ is a non-zero projection, then $p\mathcal{A}p$ is a II_1 factor on $p\mathcal{H}$. If \mathcal{A} is an infinite factor with projection p such that $p\mathcal{A}p$ is a II_1 factor, then \mathcal{A} is a II_{∞} factor. There are non-zero projections in a II_1 factor of arbitrarily small trace. Further, the trace gives an isomorphism from the equivalence classes of projections on a II_1 factor to the interval $[0, 1]$. For a II_{∞} factor the decomposition as $II_1 \otimes \mathcal{B}(\mathcal{H})$ gives a trace defining an isomorphism from the projection equivalence classes to the interval $[0, \infty]$. We shall avoid further classifications of type III factors. Finite dimensional factors are type I factors, and are simply the matrix algebras $M_n(\mathbb{C})$ acting on \mathbb{C}^n . A general finite dimensional von Neumann algebra is then just a direct sum of matrix algebras [38, 61].

The simplest and most important example of a II_1 factor is the *hyperfinite factor*. A von Neumann algebra \mathcal{A} is called hyperfinite if there is an increasing sequence of finite dimensional $*$ -subalgebras $A_n \subset \mathcal{A}$ such that their weak closure is \mathcal{A} . Up to isomorphism, there is a unique hyperfinite II_1 factor [51]. Another example is given by *group von Neumann algebras*. Let G be a group, and form the Hilbert space $l^2(G)$. This is just the set of sequences $(\alpha_{\gamma \in G})$, $\alpha_{\gamma} \in \mathbb{C}$, of length $|G|$, with the inner product given by $\langle \alpha, \beta \rangle := \sum_{\gamma \in G} \alpha_{\gamma} \bar{\beta}_{\gamma}$. We can define unitary operators on this by u_{γ} such that $u_{\gamma}(\alpha_{\rho}) := \alpha_{\gamma\rho}$. The group von Neumann algebra $vN(G)$ is then just the von Neumann algebra generated by all such unitary operators. If the conjugacy classes of G are all infinite except for the identity (known as an *I.C.C. group*), then $vN(G)$ is a II_1 factor. Note that $vN(G)$ is only isomorphic to the group algebra $\mathbb{C}G$ when G is a finite group.

If we were to find an algebra that behaves as a von Neumann algebra, we might wish to find a Hilbert space on which the algebra acts. This can be achieved by the *GNS construction*. Using the trace on a II_1 factor \mathcal{A} , we can define an inner product by $\langle x, y \rangle := \text{tr}(y^*x)$. Taking the quotient of this by the ideal $N := \{x \in \mathcal{A} : \text{tr}(x^*x) = 0\}$ we then get a positive definite inner product and so a pre-Hilbert space. The completion of this is referred to as $L^2(\mathcal{A}, \text{tr})$, often written as just $L^2(\mathcal{A})$. As the trace on a II_1 factor is faithful, $L^2(\mathcal{A}, \text{tr})$ is just the closure of \mathcal{A} in the norm $\|x\|_2 := \sqrt{\text{tr}(x^*x)}$. Elements of \mathcal{A} can be viewed as both operators or elements of the Hilbert space, with the operators acting by the algebra multiplication. In this way, $L^2(\mathcal{A})$ can be considered an \mathcal{A} -module.

Given another Hilbert space \mathcal{K} , then $L^2(\mathcal{A}) \otimes \mathcal{K}$ is also an \mathcal{A} -module. Larger \mathcal{A} -modules can be constructed as direct sums. The following theorem in turn gives details on how a Hilbert space breaks down into \mathcal{A} -modules:

Let \mathcal{A} be a II_1 factor and \mathcal{H} be a separable \mathcal{A} -module. Then there is an isometry $u : \mathcal{H} \rightarrow L^2(\mathcal{A}) \otimes l^2(\mathbb{N})$ such that $ux = (x \otimes 1)u$. Further, $uu^* \in \mathcal{A}'$ on $L^2(\mathcal{A}) \otimes l^2(\mathbb{N})$ and $\text{tr}(uu^*)$ is independent of u . The number $\text{tr}(uu^*)$ is called the *coupling constant*, denoted $\dim_{\mathcal{A}} \mathcal{H}$. Note that if \mathcal{A} were replaced with \mathbb{C} in the above, then the coupling constant would be the dimension of \mathcal{H} .

Some elementary properties of the coupling constant:

1. $\dim_{\mathcal{A}} L^2(\mathcal{A}) = 1$

2. $\dim_{\mathcal{A}}(L^2(\mathcal{A}) \otimes l^2(\mathbb{N})) = \infty$
3. $\dim_{\mathcal{A}} \mathcal{H} < \infty$ iff \mathcal{A}' is a II_1 factor
4. $\dim_{\mathcal{A}} \mathcal{H} = \dim_{\mathcal{A}} \mathcal{K}$ iff there is a unitary u such that $\mathcal{H} = u\mathcal{K}u^*$
5. For countably many \mathcal{A} -modules \mathcal{H}_i , $\dim_{\mathcal{A}}(\oplus_i \mathcal{H}_i) = \sum_i \dim_{\mathcal{A}} \mathcal{H}_i$
6. $\dim_{\mathcal{A}}(L^2(\mathcal{A})q) = \text{tr}(q)$ for any projection $q \in \mathcal{A}$
7. For a projection $p \in \mathcal{A}$, $\dim_{p\mathcal{A}p}(p\mathcal{H}) = \text{tr}(p)^{-1} \dim_{\mathcal{A}} \mathcal{H}$

From the fifth and sixth points, we see that we can construct a \mathcal{H} such that $\dim_{\mathcal{A}} \mathcal{H} = r$ for any value of $r \in [0, \infty]$.

2.2 Basics of Subfactors

An interesting example for the coupling constant comes from the group and subgroup $G_0 < G$ when they are both ICC groups. In this case, $l^2(G)$ is a $vN(G_0)$ -module, and $\dim_{vN(G_0)}(l^2(G)) = [G : G_0]$. Since they are both ICC groups, $vN(G)$ and $vN(G_0)$ are both II_1 factors, and because of the subgroup inclusion, we must have $vN(G_0) \subseteq vN(G)$. Hence we have a factor sitting inside another factor. This inclusion of factors is called a *subfactor*.

Let \mathcal{A} be a II_1 factor and G a finite group with an action on \mathcal{A} . Then the algebra of fixed points under the action of G , denoted \mathcal{A}^G is a II_1 factor, and $\mathcal{A}^G \subset \mathcal{A}$ with $\dim_{\mathcal{A}^G} \mathcal{A} = |G|$. Further, if H is another group and $\mathcal{A}^G \cong \mathcal{A}^H$ then $G \cong H$. If H is a subgroup of G , then $\mathcal{A}^G \subseteq \mathcal{A}^H$ is an inclusion of factors, with $\dim_{\mathcal{A}^G} L^2(\mathcal{A}^H) = [G : H]$. Similar results are achieved for a cross product action of groups [32].

These results led to the introduction by Jones of the notion of *index* for subfactors [33]. If $\mathcal{A} \subseteq \mathcal{B}$ is an inclusion of II_1 factors, the index of \mathcal{A} in \mathcal{B} is $[\mathcal{B} : \mathcal{A}] = \dim_{\mathcal{A}} L^2(\mathcal{B})$. The index is an invariant of subfactors, and forms the basis for their classification. Some properties of the index include:

1. $[\mathcal{B} : \mathcal{A}] = 1 \Rightarrow \mathcal{A} = \mathcal{B}$
2. If \mathcal{B} acts on a Hilbert space \mathcal{H} with $\dim_{\mathcal{A}} \mathcal{H} < \infty$ then $[\mathcal{B} : \mathcal{A}] = \dim_{\mathcal{A}} \mathcal{H} / \dim_{\mathcal{B}} \mathcal{H} = [\mathcal{A}' : \mathcal{B}']$
3. If $\mathcal{A} \subseteq \mathcal{B} \subseteq \mathcal{C}$ are II_1 factors then $[\mathcal{C} : \mathcal{A}] = [\mathcal{C} : \mathcal{B}][\mathcal{B} : \mathcal{A}]$

4. If $\mathcal{A}' \cap \mathcal{B} \neq \mathbb{C}1$ then $[\mathcal{B} : \mathcal{A}] \geq 4$

For point four, a subfactor is called *irreducible* if $\mathcal{A}' \cap \mathcal{B} = \mathbb{C}1$. So every subfactor of index less than 4 is irreducible. As a different example of a subfactor, let \mathcal{A} be a II_1 factor. Then $\mathcal{A} \otimes M_k(\mathbb{C})$ is also a II_1 factor, and contains \mathcal{A} . But $L^2(\mathcal{A} \otimes M_k(\mathbb{C}))$ is just the direct sum of k^2 copies of $L^2(\mathcal{A})$, so $[\mathcal{A} \otimes M_k(\mathbb{C}) : \mathcal{A}] = k^2$. This allows for a large choice of index values, which can be increased even more by the following construction:

Let R be the hyperfinite II_1 factor, and p a projection in R . By hyperfiniteness, there is an isomorphism $\theta : pRp \rightarrow (1-p)R(1-p)$. Let $N := \{x + \theta(x) : x \in pRp\}$. Then $N \subseteq R$ is a subfactor, with index $[R : N] = (\text{tr}(p))^{-1} + (1 - \text{tr}(p))^{-1}$. As we can choose p so that $\text{tr}(p)$ takes any value in $[0, 1]$, we have $[R : N] \geq 4$ for this construction.

From now on, we will use M, N to denote II_1 factors.

For any subfactor $N \subseteq M$, there is a map $E_N : M \rightarrow N$ called the *conditional expectation*, with the following properties:

1. $E_N^2 = E_N$
2. $E_N(x^*) = E_N(x)^*$, $E_N(1) = 1$, $E_N(x^*x) = 0$ iff $x = 0$
3. $E_N(x^*x) \geq E_N(x^*)E_N(x)$, $\|E_N(x)\| \leq \|x\|$
4. $E_N(axb) = aE_N(x)b$ for $a, b \in N$
5. E_N is ultraweakly continuous
6. $\text{tr}_N E_N = \text{tr}_M$ (E_N preserves the trace)

E_N extends to a projection $\mathbf{e}_N : L^2(M) \rightarrow L^2(N)$. A fundamental result of subfactors, is that given this projection, $\langle M, \mathbf{e}_N \rangle := \{M, \mathbf{e}_N\}''$ is a II_1 factor with $M \subseteq \langle M, \mathbf{e}_N \rangle$ such that $[\langle M, \mathbf{e}_N \rangle : M] = [M : N]$. This led Jones [33] to introduce his **basic construction on subfactors**:

Given a subfactor $N \subseteq M$, then setting $N := M_0$, $M := M_1$, we can form the tower of algebras; $M_0 \subseteq M_1 \subseteq M_2 \subseteq \dots \subseteq M_n \dots$ where $\mathbf{e}_{i-1}L^2(M_i) = L^2(M_{i-1})$, $M_{i+1} = \langle M_i, \mathbf{e}_{i-1} \rangle$, and each M_i is a II_1 factor with $[M_i : M_{i-1}] = [M_1 : M_0]$.

The projections \mathbf{e}_i satisfy the following properties:

1. $\mathbf{e}_i^2 = \mathbf{e}_i^* = \mathbf{e}_i$
2. $\mathbf{e}_i \mathbf{e}_{i\pm 1} \mathbf{e}_i = \tau \mathbf{e}_i$
3. $\mathbf{e}_i \mathbf{e}_j = \mathbf{e}_j \mathbf{e}_i$ if $|i - j| \geq 2$
4. $\text{tr}(\omega \mathbf{e}_{i+1}) = \tau \text{tr}(\omega)$ where ω is a word on $\{\mathbf{e}_1, \dots, \mathbf{e}_i\}$

where $\tau^{-1} := [M : N]$. The first three properties are also known as the *Temperley-Lieb relations* [62], and elements satisfying them generate an algebra (along with 1) of dimension $\frac{1}{i+2} \binom{2i+2}{i+1}$. Using these relations, Jones and Wenzl [33, 64] were able to put restrictions on the possible values of the index of a subfactor. They found that for any II_1 subfactor $N \subseteq M$, $[M : N] \in \{4 \cos^2(\frac{\pi}{n}) : n \geq 3\} \cup [4, \infty]$. We have seen a construction that gives the values $[4, \infty]$, but the smaller values are a very interesting result. They show that the index is quantized, which motivated attempts to classify these small index subfactors, and to see if apart from the given construction, if there is any restrictions on the possible larger index values. The first step in achieving this was to introduce further invariants of subfactors, that would allow further categorization, as well as the ability to recover the subfactor from the invariants.

Given the basic construction of a subfactor, we can form another tower:

$\mathbb{C} = N' \cap N \subseteq N' \cap M \subseteq N' \cap M_2 \dots N' \cap M_n \dots$. Let $P_k := N' \cap M_k$. Then this tower consists of a sequence of inclusions of finite dimensional C^* -algebras. Each P_k is then isomorphic to a direct sum of matrix algebras. Let $P_k = \oplus_i M_{n_i}(\mathbb{C})$ and $P_{k+1} = \oplus_j M_{n_j}(\mathbb{C})$. Since $P_k \subseteq P_{k+1}$, then there are inclusion maps $\oplus_x M_{i_x}(\mathbb{C}) \hookrightarrow M_{j_y}(\mathbb{C})$, $\sum_x i_x \leq j_y$. Forming a matrix with rows indexed by the i_x and columns indexed by the j_y whose entries are non-zero if there is an inclusion map $M_{i_x}(\mathbb{C}) \hookrightarrow M_{j_y}(\mathbb{C})$, and the entry is the multiplicity of the inclusion. For example, the inclusion $M_2(\mathbb{C}) \oplus M_3(\mathbb{C}) \oplus \mathbb{C} \hookrightarrow M_5(\mathbb{C}) \oplus M_4(\mathbb{C})$ is described by the matrix:

$$\begin{pmatrix} 1 & 0 \\ 1 & 1 \\ 0 & 1 \end{pmatrix}$$

These inclusion matrices take the form of the adjacency matrix of a bipartite graph, which consists of two rows of vertices, the upper row indexed by the rows of the matrix, the lower

row indexed by the columns of the matrix, and the number of edges between the i th vertex on the upper row and the j th vertex on the lower row is simply the value of the i, j th matrix entry.

To our tower of P_k algebras, we can associate a bipartite graph to each inclusion, and as the lower row of the k th graph will have the same vertices of the upper row of the $k + 1$ th graph, we can adjoin the graphs to one-another to build a Bratelli diagram, whose k th row has vertices indexed by the dimensions of the matrices in P_k . Note now, that each P_k is generated from the previous algebra, and this enforces a symmetry on the bratelli diagram, such that the edges between the k th and $K + 1$ th rows are just the reflection of the edges between the $K - 1$ th and k th rows, plus some new parts. Hence, by this reflection symmetry, and given $P_0 = \mathbb{C}$, we can generate the entire bratelli diagram just by knowing the new parts added at each row. If we delete the non-new stuff from the bratelli diagram, the new stuff left forms a bipartite graph. From its construction, this graph contains the inclusion information of our tower of P_k 's and hence forms an invariant of the subfactor. It is referred to as the *principal graph*. There is also a *dual principal graph*, formed from the tower $M' \cap M \subseteq M' \cap M_2 \subseteq \dots$

The principal (and dual principal) graph Γ of a subfactor $N \subseteq M$ has the property $\|\Gamma\|^2 = [M : N]$, and together they describe how the tower of subfactors are contained in one-another. They allowed for a classification of small index subfactors, as the possible bipartite graphs with norm less than 2 was already a well known result. The possible graphs are known as *ADE* graphs, and consist of A_n, D_n, E_6, E_7, E_8 , with $\|A_n\| = 2 \cos(\frac{\pi}{n+1})$, $\|D_n\| = 2 \cos(\frac{\pi}{2n-2})$, $\|E_6\| = 2 \cos(\frac{\pi}{12})$, $\|E_7\| = 2 \cos(\frac{\pi}{18})$, $\|E_8\| = 2 \cos(\frac{\pi}{30})$.

Izumi [29] showed that of these graphs, the D_n with n odd, and E_7 aren't allowed. He then went on to give an example of the construction of E_8 [30]. Similarly, E_6 was constructed in [3], and D_{2n} in [41]. The A_n are generated from the Temperley-Lieb relations, quotiented by the n th *Jones-Wenzl projection*, detailed in [64]. In each case, the bipartite graph is finite, and their corresponding subfactors are known as *finite depth* subfactors.

The bipartite graphs of norm 2, corresponding to subfactors of index 4, also consist of ADE graphs, but now include some infinite depth graphs. The subfactors of index 4 were classified by Popa [57], and can all be considered to come from subgroups of $SU(2)$. Of special interest is D_∞ , which can be considered to be the composition of two subfactors of index 2, which is an example of a *Fuss-Catalan subfactor* [5].

2.3 The Standard Invariant

Two constructions introduced to help understand subfactors are the *paragroup*, introduced by Ocneanu [53], and the λ -*lattice*, introduced by Popa [56]. Both of these constructions turned out to rely on a subfactor invariant known as the *standard invariant*, which contains a more detailed version of the information in the principal graph. It also allows the recovery of the original subfactor, up to isomorphism, for inclusions of the hyperfinite II_1 factor with finite principal graph [56].

For a subfactor $N \subseteq M$, its standard invariant is the tower of commuting squares:

$$\begin{array}{ccccccc} \mathbb{C} = & N' \cap N & \subset & N' \cap M & \subset & N' \cap M_2 & \subset & N' \cap M_3 & \subset & \dots \\ & & & \cup & & \cup & & \cup & & \\ & & & \mathbb{C} & & \mathbb{C} & & \mathbb{C} & & \\ & & & & & & & & & \\ & & & \mathbb{C} = & M' \cap M & \subset & M' \cap M_2 & \subset & M' \cap M_3 & \subset & \dots \end{array}$$

These commuting squares consist of the inclusions of two towers of finite dimensional C^* -algebras;

$$\begin{array}{ccccccc} \mathbb{C} = & P_{0+} & \subset & P_{1+} & \subset & P_{2+} & \subset & \dots \\ & & & \cup & & \cup & & \\ & & & \mathbb{C} & & \mathbb{C} & & \\ & & & & & & & \\ & & & \mathbb{C} = & P_{0-} & \subset & P_{1-} & \subset & \dots \end{array}$$

Taking the limit we get: $\lim_{k \rightarrow \infty} P_{k-} \subset P_{k+1,+} = P_{\infty-} \subset P_{\infty+} \cong N \subset M$.

Popa went on to prove classification results for when the principal graph is infinite, that hold for all subfactors with index ≤ 4 .

Several different methods have been introduced to study the standard invariant, including paragroups, λ -lattices and a categorical approach, but the method favoured in current research is *planar algebras*, introduced by Jones [35, 37].

2.4 Planar Algebras

To discuss planar algebras, we first need to introduce the notion of a *planar tangle*. A planar tangle consists of an outer box, and a number (possibly zero) of inner boxes. There

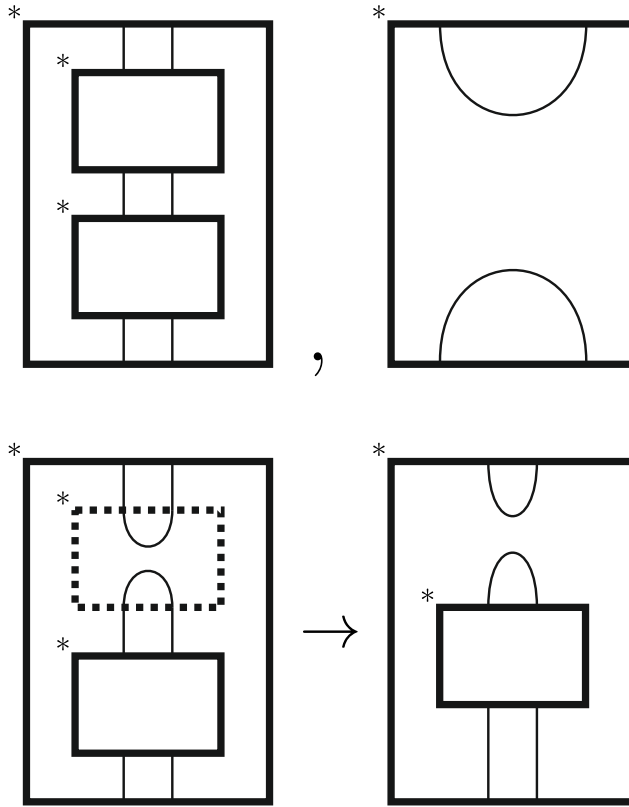

Figure 2.1: Top: T, S . Bottom: $S \circ T$

is a marked point (*) associated to each box, although it is often taken as the top left corner, when all boxes are kept oriented with the page. Each box has a number of boundary points along the top and bottom, the number of which is often called the *colour* of the box. These boundary points form the start and end points for a set of non-overlapping strings, which can also form closed loops. Each tangle is considered to be unique up to diffeomorphism. Multiple parallel strings are sometimes depicted by a single thick string.

Extra structure can be added to a tangle, for example by orientating strings, or by introducing a chequerboard shading. In the case of a chequerboard shading, it depends only on the shading given to a single section, so is often defined based on the shading given to the section containing the marked point of the outer box, and sometimes labelled + for unshaded, and - for shaded.

There is a natural form of composition of compatible tangles. Given two tangles S and T , if the outer box of S has colour k , and an inner box t of T also has colour k , then we can insert S into t with marked points aligned, then join and smooth strings, and delete the outer box of S . This composition is denoted $S \circ_t T$.

Each tangle T can be considered as a multilinear map on vector spaces P_{k_i} , where k_i are the colours of the inner boxes of T , and k_0 is the colour of the outer box of T . The

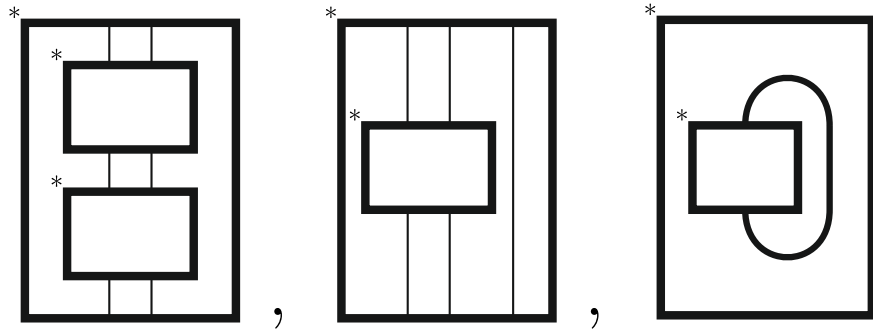

Figure 2.2: Multiplication, Inclusion and Trace tangles.

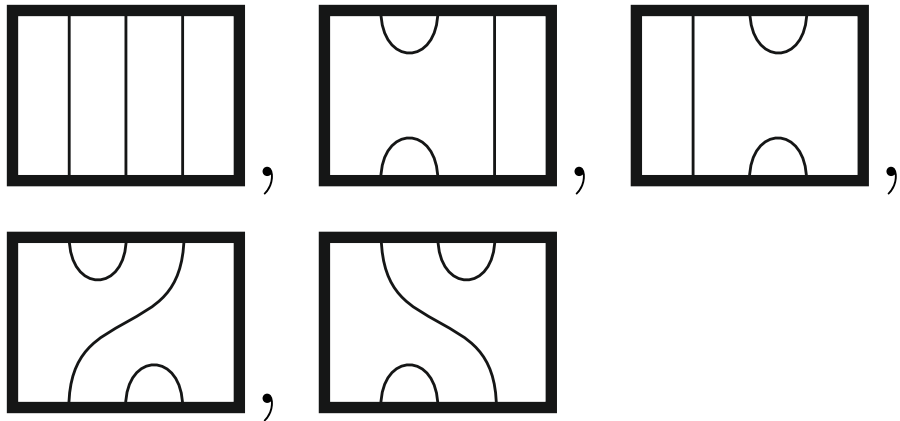

Figure 2.3: Basis of TL_3

map then has a presentation $Z_T : P_{k_1} \otimes \dots \otimes P_{k_i} \rightarrow P_{k_0}$. There is a set of multiplication maps that turn each P_k into an algebra, as well as inclusion maps that allow smaller P_k to be viewed as subalgebras of P_{k+n} . A Planar Algebra is then defined to be a set of vector spaces that form a series of algebras under the action of tangles. There is a natural involution on the tangles by taking the reflection, which turns each P_k into a $*$ -algebra. An inner product can also be defined using the trace tangle by setting $\langle x, y \rangle := tr(xy^*)$ where we define the trace of the empty tangle as $tr(\square) := 1$. Note that this inner product isn't necessarily positive definite. For this inner product to work, we also need the notion of the modulus, which is a scalar δ such that removing a closed string loop from a tangle is equivalent to multiplying the resulting tangle by δ .

The simplest example of a planar algebra is the pictorial representation of the Temperley-Lieb algebra introduced by Kauffman [40]. In this case, a basis for the n th algebra, TL_n is given by a box with no internal boxes and $2n$ boundary points, and the basis taken over each possible way of joining n non-intersecting strings to those points. A more compli-

cated example is the graph planar algebra, which associates a planar algebra $G(\Gamma)$ to a bipartite graph.

A *subfactor planar algebra* is defined to be a positive definite planar algebra with shading, such that each $P_{n\pm}$ has finite dimension, $\dim P_{0\pm} = 1$, and it is *spherical*. The spherical requirement can be thought of as requiring that the involution and shading don't affect the trace. Under these requirements, each $P_{n\pm}$ of a subfactor planar algebra forms a finite dimensional C^* -algebra, and so form the towers of a standard invariant.

A fundamental result on planar algebras is the combined work of Jones and Popa [35, 58], which can be taken as saying there is a bijection between subfactors and subfactor planar algebras. Further the index of the subfactor is equal to the square of the modulus δ , and the principal graph is the same for both subfactor and planar algebra.

This then gives a way for discovering new subfactors, but there is no guarantee that planar algebras simplify the process in any way. There are some tools available through planar algebras that may help however. The first is that as the planar tangles with no internal boxes are just elements of the Temperley-Lieb algebra, then there is a mapping from $TL(\delta)$ to any planar algebra with the same value of δ . Secondly, there is a natural decomposition over modules for any planar algebra. An *annular- (n, k)* tangle is a tangle with one internal box, whose internal colour is n , and external colour is k . It is clear that inserting any tangle into an annular tangle will result in an action on the inserted tangle, and so any planar algebra must consist of modules over the annular tangles. Thirdly, given the principal graph of a subfactor, there is an embedding of its subfactor planar algebra into the graph planar algebra of its principal graph [31].

Using these tools has allowed the construction of subfactor planar algebras for all ADE subfactors [2, 48], as well as putting some constraints on possible principal graphs.

Although as stated earlier the index can take any possible value greater than 4, it turns out that if you ignore subfactors with A_∞ as their principal graph, then the possible index values become quantised. The combined work of many people has allowed for the classification of these values up to index 5 [37].

The first step in the classification was to find possible principal graphs with norm in the correct range, which was done by several people, with the full range being covered through the use of computers. The set of possible graphs is then narrowed down using various constraints until only a small number are left for which the construction of a

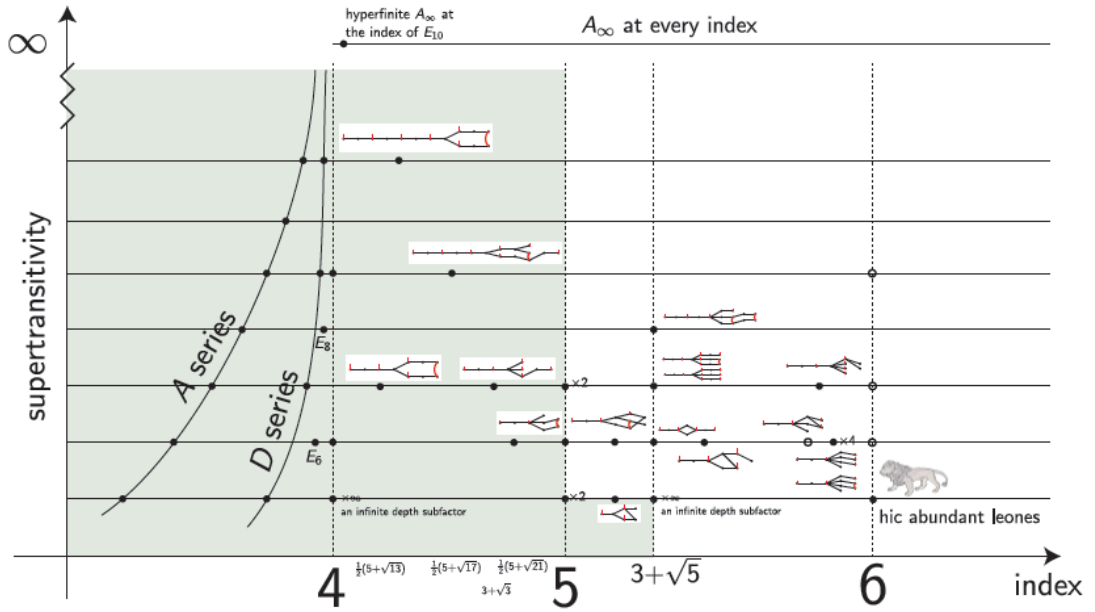

Figure 2.4: The map of low index subfactors. The shaded regions indicate complete classification and filled dots indicate known subfactors. Open dots indicate some possible candidate principal graphs. Taken from [37].

subfactor can be attempted. The first and most general constraint on the graphs is an *associativity* test, which enforces conditions on the possible paths on a principal graph and its dual. Combined with a theorem by Ocneanu on *triple point constructions* [27], it allows for large numbers of graphs to be eliminated. Other constraints come from a combination of combinatorics and linear algebra, but the most surprising result is the appearance of a number of constraints arising from number theory [54].

Using these results has allowed for the restriction of the possible principal graphs for subfactors in the range $4 < [M : N] < 5$ to just 5 principal-dual graph pairs. Each of these graph pairs gives rise to two subfactors, giving 10 unique subfactors in the range. At index equal to 5 there are a further 7 subfactors, all coming from finite group constructions. Several subfactors of larger index have also been found, and there are ongoing attempts to increase the range of known classification. It isn't yet known how far the index quantization extends, but is believed to stop at 6, although the reasoning for this could allow it to stop at as low as $3 + \sqrt{5}$.

2.5 Tensor Categories

For more detailed introductions to fusion and tensor categories, as well as further background such as the definition of an abelian category, see [9, 15, 16, 46, 49]. Throughout this section we denote by \mathcal{C} a \mathbb{K} -linear abelian category. By a *simple object* we mean one such that $\text{Hom}(X, X) \simeq \mathbb{K}$. An abelian category is *semisimple* if every object is isomorphic to a direct sum of a finite number of simple objects.

A *tensor category* is a \mathbb{K} -linear abelian category along with the following:

- A bifunctor $\otimes : \mathcal{C} \times \mathcal{C} \rightarrow \mathcal{C}$,
- A natural isomorphism $\alpha_{X,Y,Z} : (X \otimes Y) \otimes Z \rightarrow X \otimes (Y \otimes Z)$, $X, Y, Z \in \mathcal{C}$,
- A simple object $\mathbf{1} \in \mathcal{C}$ and natural isomorphisms $\iota_l : \mathbf{1} \otimes X \rightarrow X$, $\iota_r : X \otimes \mathbf{1} \rightarrow X$, $X \in \mathcal{C}$,

that satisfy the *pentagon* and *triangle* axioms.

The *pentagon* axiom:

$$\begin{array}{ccc} ((A \otimes B) \otimes C) \otimes D & \xrightarrow{\alpha_{A,B,C}} & (A \otimes (B \otimes C)) \otimes D & \xrightarrow{\alpha_{A,(B \otimes C),D}} & A \otimes ((B \otimes C) \otimes D) \\ & \searrow \alpha_{(A \otimes B),C,D} & & & \downarrow \alpha_{B,C,D} \\ & & (A \otimes B) \otimes (C \otimes D) & \xrightarrow{\alpha_{A,B,(C \otimes D)}} & A \otimes (B \otimes (C \otimes D)) \end{array}$$

The *triangle* axiom:

$$\begin{array}{ccc} (X \otimes \mathbf{1}) \otimes Y & \xrightarrow{\alpha_{X,\mathbf{1},Y}} & X \otimes (\mathbf{1} \otimes Y) \\ & \searrow \iota_r \otimes id_Y & \downarrow id_X \otimes \iota_l \\ & & X \otimes Y \end{array}$$

We refer to \otimes , α , and $\mathbf{1}$ as the tensor product, associativity map, and unit, respectively.

An object $X^* \in \mathcal{C}$ is called a *left dual* of X , if there are maps $ev_X : X^* \otimes X \rightarrow \mathbf{1}$ and $cv_X : \mathbf{1} \rightarrow X^* \otimes X$ such that:

$$\begin{aligned} (cv_X \otimes id_X) \alpha_{X,X^*,X}(id_X ev_X) &= id_X \\ (id_{X^*} \otimes cv_X) \alpha_{X^*,X,X^*}^{-1}(ev_X \otimes id_{X^*}) &= id_{X^*} \end{aligned}$$

ev_X and cv_X are referred to as the evaluation and coevaluation maps respectively. The *right dual* of X is defined similarly.

A tensor category is called *rigid* if every object has left and right duals. It is *pivotal* if

there is a natural isomorphism $X \rightarrow X^{**}$. A *fusion* category is a rigid semisimple tensor category with a finite number of simple objects. In a fusion category, right and left duals are isomorphic.

Given an tensor category \mathcal{C} , and direct sums of objects, $A_1 \oplus \dots \oplus A_n$, $B_1 \oplus \dots \oplus B_m$, morphisms between them can be considered as matrices as follows:

$$\text{Hom}_{\mathbb{K}}(A_1 \oplus \dots \oplus A_n, B_1 \oplus \dots \oplus B_m) := \begin{pmatrix} \text{Hom}(A_1, B_1) & \cdots & \text{Hom}(A_n, B_1) \\ \text{Hom}(A_1, B_2) & \cdots & \text{Hom}(A_n, B_2) \\ \vdots & \ddots & \vdots \\ \text{Hom}(A_1, B_m) & \cdots & \text{Hom}(A_n, B_m) \end{pmatrix},$$

$$A_i, B_j \in \mathcal{C}$$

The tensor product is distributive in the obvious way with the direct sum:

$$(A_1 \oplus A_2) \otimes (B_1 \oplus B_2) = (A_1 \otimes B_1) \oplus (A_1 \otimes B_2) \oplus (A_2 \otimes B_1) \oplus (A_2 \otimes B_2).$$

Given a fusion category \mathcal{C} with isomorphism classes of simple objects $\{X_i\}$, where $X_0 := \mathbf{1}$, the fusion coefficients N_{ij}^k are defined as the multiplicity of X_k in the tensor decomposition of $X_i \otimes X_j$.

A braiding on a tensor category is a set of isomorphisms $c_{X,Y} : X \otimes Y \rightarrow Y \otimes X$ for each pair of objects $X, Y \in \mathcal{C}$ that satisfies the *hexagon* identities:

$$\begin{array}{ccccc} (A \otimes B) \otimes C & \xrightarrow{\alpha_{A,B,C}} & A \otimes (B \otimes C) & \xrightarrow{c_{A,(B \otimes C)}} & (B \otimes C) \otimes A \\ \downarrow c_{A,B} & & & & \downarrow \alpha_{B,C,A} \\ (B \otimes A) \otimes C & \xrightarrow{\alpha_{B,A,C}} & B \otimes (A \otimes C) & \xrightarrow{c_{A,C}} & B \otimes (C \otimes A) \end{array}$$

$$\begin{array}{ccccc} (A \otimes B) \otimes C & \xrightarrow{\alpha_{A,B,C}} & A \otimes (B \otimes C) & \xrightarrow{c_{A,(B \otimes C)}^{-1}} & (B \otimes C) \otimes A \\ \downarrow c_{A,B}^{-1} & & & & \downarrow \alpha_{B,C,A} \\ (B \otimes A) \otimes C & \xrightarrow{\alpha_{B,A,C}} & B \otimes (A \otimes C) & \xrightarrow{c_{A,C}^{-1}} & B \otimes (C \otimes A) \end{array}$$

A braiding is called *symmetric* if $c_{Y,X}c_{X,Y} = id_{X \otimes Y}$ for all $X, Y \in \mathcal{C}$.

A *twist* is an automorphism $\theta_X : X \rightarrow X$, for all $X \in \mathcal{C}$ such that

$$\begin{aligned} \theta_{X \otimes Y} &= (\theta_X \otimes \theta_Y) c_{Y,X} c_{X,Y} \\ (\theta_X)^* &= \theta_{X^*} \end{aligned}$$

for all $X, Y \in \mathcal{C}$. A tensor category is called *ribbon* if it has a braiding and twist. A *modular tensor category* is a ribbon fusion category. The *Categorical Dimension* of a

tensor category is defined as $Dim(\mathcal{C}) = \sum_{X \in Irr(\mathcal{C})} d(X)^2$, $d(X) := tr(1_X)$, where $Irr(\mathcal{C})$ is the set of simple objects in \mathcal{C} . Given a modular tensor category, we can derive two matrices S, T , known as modular invariants, which give a representation of the modular group $SL(2, \mathbb{Z})$. These are defined as:

$$S := \frac{1}{\sqrt{Dim(\mathcal{C})}} \tilde{S} \quad \tilde{S} := (\tilde{S}_{X,Y})_{X,Y \in Irr(\mathcal{C})} \quad \tilde{S}_{X,Y} := tr(R_{X,Y} R_{Y,X}) \quad (2.1)$$

$$T := \frac{1}{(\xi(\mathcal{C}))^{\frac{1}{3}}} diag(\theta_X) \quad \xi(\mathcal{C}) := \frac{1}{\sqrt{Dim(\mathcal{C})}} \sum_{X \in Irr(\mathcal{C})} \theta_X d(X)^2 \quad \xi(\mathcal{C}) \neq 0 \quad (2.2)$$

These matrices provide a way of checking that the solutions for the category are correct [6, 17]. Notably, we can recover the fusion rules using the *Verlinde* formula:

$$N_{ij}^k = \sum_{\rho} \frac{S_{i,\rho}}{S_{0,\rho}} S_{j,\rho} \bar{S}_{k,\rho} \quad (2.3)$$

Where $\bar{s} = s$ if \mathbb{K} has no complex elements. Given $h_k \in \mathbb{K}$, such that $\theta_{X_k} = e^{2i\pi h_k}$, we have:

$$S_{i,j} = S_{0,0} \sum_{\rho} exp(2i\pi(h_i + h_j - h_{\rho})) N_{i,j}^{\rho} d(X_{\rho}) \quad (2.4)$$

Finally we have that for some permutation matrix P :

$$(ST)^3 = P \quad (2.5)$$

There is a close relationship between fusion categories and planar algebras that comes from the following construction. Given a fusion category \mathcal{C} , and a chosen object $X \in \mathcal{C}$, consider the following:

$$\begin{array}{ccccccc} \mathbb{K} & \subset & End(X) & \subset & End(X \otimes X^*) & \subset & End(X \otimes X^* \otimes X) & \subset & \dots \\ & & \cup & & \cup & & \cup & & \\ & & \mathbb{K} & \subset & End(X^*) & \subset & End(X^* \otimes X) & \subset & \dots \end{array}$$

This can be described as a (shaded) planar algebra, with the Temperley-Lieb generators given by compositions of the evaluation and co-evaluation maps:

$$\mathbf{e}_1 := ev_X cv_X : X \otimes X^* \rightarrow \mathbf{1} \rightarrow X \otimes X^*$$

If the chosen object is self-dual, then the planar algebra is a diagrammatic description of $End(X^{\otimes n})$.

2.6 Quantum Groups

For general references to Hopf algebras and quantum groups, see [12, 39, 44].

Let \mathbb{K} be a field, and A a vector space over \mathbb{K} with tensor product \otimes . A is called an *algebra* if there are maps $\mu : A \otimes A \rightarrow A$ and $\eta : \mathbb{K} \rightarrow A$, called the *multiplication* and *unit* maps respectively, such that the following diagrams commute:

$$\begin{array}{ccccc}
 A \otimes A \otimes A & \xrightarrow{\mu \otimes id} & A \otimes A & & \mathbb{K} \otimes A & \xrightarrow{\eta \otimes id} & A \otimes A & \xleftarrow{id \otimes \eta} & A \otimes \mathbb{K} \\
 id \otimes \mu \downarrow & & \downarrow \mu & & \searrow & & \downarrow \mu & & \swarrow \\
 A \otimes A & \xrightarrow{\mu} & A & & & & A & &
 \end{array}$$

Similarly A is called a *coalgebra* if there are maps $\Delta : A \rightarrow A \otimes A$ and $\varepsilon : A \rightarrow \mathbb{K}$, called the *comultiplication* and *counit* maps respectively, such that the following diagrams commute:

$$\begin{array}{ccccc}
 A & \xrightarrow{\Delta} & A \otimes A & & \mathbb{K} \otimes A & \xleftarrow{1 \otimes} & A & \xrightarrow{\otimes 1} & A \otimes \mathbb{K} \\
 \Delta \downarrow & & \downarrow \Delta \otimes id & & \varepsilon \otimes id \swarrow & & & & \nearrow id \otimes \varepsilon \\
 A \otimes A & \xrightarrow{id \otimes \Delta} & A \otimes A \otimes A & & & & A \otimes A & &
 \end{array}$$

The comultiplication is often written using *Sweedler notation*: $\Delta(h) = \sum h_{(1)} \otimes h_{(2)}$ and $(\Delta \otimes id)\Delta(h) = \sum h_{(1)} \otimes h_{(2)} \otimes h_{(3)}$. The summation symbol is often omitted.

Let $\tau : A \otimes B \rightarrow B \otimes A$ for \mathbb{K} -vector spaces A, B . A is called a *bialgebra* if the following diagrams commute:

$$\begin{array}{ccccc}
 A \otimes A \otimes A \otimes A & & \xrightarrow{1 \otimes \tau \otimes 1} & & A \otimes A \otimes A \otimes A \\
 \Delta \otimes \Delta \uparrow & & & & \downarrow \mu \otimes \mu \\
 A \otimes A & \xrightarrow{\mu} & A & \xrightarrow{\Delta} & A \otimes A \\
 \\
 A \otimes A & \xrightarrow{\varepsilon \otimes \varepsilon} & \mathbb{K} \otimes \mathbb{K} & & A \otimes A & \xleftarrow{\eta \otimes \eta} & \mathbb{K} \otimes \mathbb{K} \\
 \mu \downarrow & & \downarrow \simeq & & \Delta \uparrow & & \uparrow \simeq \\
 A & \xrightarrow{\varepsilon} & \mathbb{K} & & A & \xleftarrow{\eta} & \mathbb{K}
 \end{array}$$

A map $S : A \rightarrow A$ is called an *antipode* if the following diagram commutes:

$$\begin{array}{ccccc}
 A \otimes A & \xrightarrow{S \otimes id} & A \otimes A & & \\
 \Delta \nearrow & & & & \searrow \mu \\
 A & \xrightarrow{\varepsilon} & \mathbb{K} & \xrightarrow{\eta} & A \\
 \Delta \searrow & & & & \nearrow \mu \\
 A \otimes A & \xrightarrow{id \otimes S} & A \otimes A & &
 \end{array}$$

A bialgebra with an antipode is called a *Hopf Algebra*. A Hopf algebra is called *semisimple* if it is semisimple as an algebra. The simplest example of a Hopf algebra is the group algebra $\mathbb{K}G$, with $\Delta(g) := g \otimes g$, $\varepsilon(g) := 1$, $S(g) := g^{-1}$, for all $g \in G$. In finite dimensions with \mathbb{K} of characteristic zero, the only Hopf algebras of order p for p prime, are the group algebras $\mathbb{K}[\mathbb{Z}_p]$. For p^2 , the only semisimple Hopf algebras are $\mathbb{K}[\mathbb{Z}_{p^2}]$ and $\mathbb{K}[\mathbb{Z}_p \times \mathbb{Z}_p]$. However there is also a non-semisimple Hopf algebra of dimension p^2 .

A *left module* M over a \mathbb{K} -Hopf algebra H is a \mathbb{K} -vector space with a \mathbb{K} -linear map $\lambda : H \otimes M \rightarrow M$ such that the following diagrams commute:

$$\begin{array}{ccccc}
 H \otimes H \otimes M & \xrightarrow{id \otimes \lambda} & H \otimes M & & \mathbb{K} \otimes M & \xrightarrow{\eta \otimes id} & H \otimes M \\
 \mu \otimes id \downarrow & & \downarrow \lambda & & \searrow & & \downarrow \lambda \\
 H \otimes M & \xrightarrow{\lambda} & M & & & & M
 \end{array}$$

Given two modules M_1, M_2 over a Hopf algebra H , the action on their tensor product is defined using the coproduct:

$$h(m_1 \otimes m_2) = \Delta(h)m_1 \otimes m_2 = h_{(1)}m_1 \otimes h_{(2)}m_2$$

for $h \in H$, $m_1 \in M_1$, $m_2 \in M_2$. It follows from this that the category of representations of a Hopf algebra naturally form a tensor category.

Define the flip map τ as $\tau(a \otimes b) := b \otimes a$. Given a Hopf algebra H , we say it is *cocommutative* if $\tau\Delta(h) = \Delta(h)$ for all $h \in H$.

A *quantum group* is a noncommutative and non-cocommutative Hopf algebra.

A large number of examples of quantum groups come from deformations of the universal enveloping algebra of a Lie algebra, denoted $U_q(\mathfrak{g})$, where $q \in \mathbb{K}$. When q is not a root of unity, then the representation category of $U_q(\mathfrak{g})$ can be considered equivalent to the representation category of \mathfrak{g} . When q is a root of unity the case is more complicated, as there is the appearance of negligible modules, and there are several approaches to dealing with this. The usual approach is only consider non-negligible modules, i.e. modules with non-zero trace, where the trace is defined by $\mathbf{1} \xrightarrow{cv_X} X \otimes X^* \xrightarrow{id_X \otimes id_{X^*}} X \otimes X^* \xrightarrow{ev_X} \mathbf{1}$. Doing this, we find that there is a finite number of irreducible modules, and they form a fusion category.

The simplest example of a quantum group is $U_q(\mathfrak{sl}_2)$. It turns out that its representation

theory is closely related to the Temperley-Lieb algebra, by what is known as (quantum) *Schur-Weyl Duality* [26, 45].

Let X denote the two dimensional representation of $U_q(\mathfrak{sl}_2)$. Then for q not a root of unity, $End_{U_q(\mathfrak{sl}_2)}(X^{\otimes n}) \simeq TL_n(q + q^{-1})$. Further, let f_k denote the k th Jones-Wenzl projection, and $\overline{End_{U_q(\mathfrak{sl}_2)}(X^{\otimes n})}$ denote $End_{U_q(\mathfrak{sl}_2)}(X^{\otimes n})$ quotiented by negligible modules, which include all highest weight modules of dimension greater than $k - 1$. Then for q an $2k$ th root of unity, $\overline{End_{U_q(\mathfrak{sl}_2)}(X^{\otimes n})} \simeq TL_n(q + q^{-1}) / f_{k-1}$.

Chapter 3

\mathbb{K} -Planar Algebras

The aim of this chapter is to introduce a generalised definition of planar algebras, and introduce two fundamental planar algebras, the Temperley-Lieb algebra and the bipartite graph planar algebra. These will then be used as a starting point for constructing new algebras. We then discuss the Temperley-Lieb category, and how it can be used to construct examples of fusion categories. As a demonstration, we construct examples of the semion, Ising, and Fibonacci/Yang-Lee fusion categories, giving isomorphism maps for their fusion rules, finding their associativity, braiding, and twist constraints, and using these to give their S and T matrices.

3.1 A Generalised Definition of Planar Algebras

A planar tangle consists of an outer box and some (possibly zero) number of internal boxes. Each box has a marked point ($*$) on its boundary, which if not shown, is assumed to be the top left corner. Each box has a number of points along its top and bottom, which can be numbered clockwise starting at the first point after the marked point. The number of points along the top and bottom is usually required to be equal, although this is often relaxed for practical purposes. Each point is the start/end point for a string, i.e. an embedding of \mathbb{R} , and each string must begin and end on the boundaries of boxes, or form closed loops. The strings are generally not allowed to cross, and their positions are unique up to diffeomorphism. A box with $2k$ boundary points is said to be of colour k , and a tangle is said to be a k -tangle if its outer box has colour k . We can give an orientation to the string joining to the first point on the outer box, pointing towards this point being considered positive, and alternate the orientation for strings joining the succeeding points. This allows us to give the tangle a shading, by defining that travelling along a string in

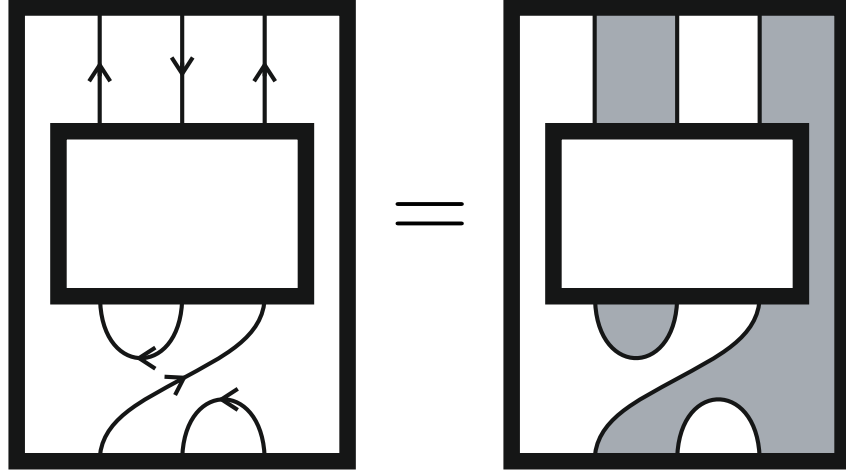

the direction of the orientation, the region to the right is shaded.

There is a natural composition on tangles, where given a k -tangle, and another tangle with an internal k -box, the composition is given by inserting the k -tangle into the k -box with their marked points aligned, then joining the corresponding strings, and removing the boundary of the k -box. Given a set of k -tangles, this can be taken as a basis and extended to form a vector space, denoted P_k . We will assume for now that all vector spaces are over a field \mathbb{K} . Take the k -tangle with two internal k -boxes aligned vertically, and connected by vertical strings, (denoted \mathcal{M}_k), then insertion of P_k elements into this forms a multiplication on P_k , and so turns P_k into an algebra. The unit for this multiplication is the k -tangle with no internal boxes, (1_k) and all strings vertical. The $k+1$ -tangle with a single k -box, connected vertically, with another string to the right, (\mathcal{I}_k^{k+1}) , forms an inclusion map from P_k to P_{k+1} . Similarly, the k -tangle with a single $k+1$ -box, connected vertically apart from the k th and $(k+1)$ th points, which are joined together, $(\mathcal{E}_{\mathcal{R}_{k+1}}^k)$, forms a map from P_{k+1} to P_k . These maps then turn $\bigcup_{k=0} P_k$ into the graded algebra P . If we consider removing a closed loop to be equivalent to multiplying the tangle by δ , for some choice of δ , then we can identify 0-tangles with no internal boxes, with the underlying field. If P_0 is 1-dimensional, then maps to it are linear functionals.

Given a k -tangle T with n internal boxes of colours k_1, \dots, k_n and a graded algebra P , a presentation of T is a multilinear map $Z_T : P_{k_1} \otimes P_{k_2} \otimes \dots \otimes P_{k_n} \rightarrow P_k$, which is given by inserting elements of P_{k_i} into the k_i th box, and identifying the result as an element of P_k . A planar algebra is a graded algebra that is well-defined over the presentation of any tangle. It is called *connected* if $\dim P_0 = 1$ and *irreducible* if $\dim P_1 = 1$. We can define an

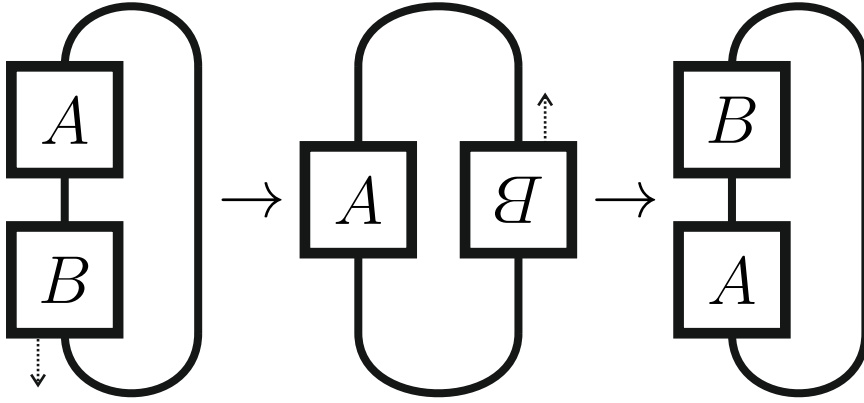

Figure 3.1: Cyclic property of the trace tangle.

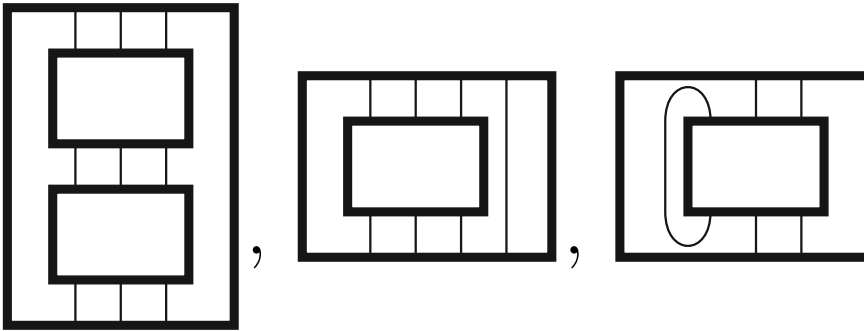

Figure 3.2: $\mathcal{M}_3, \mathcal{I}_{\mathcal{R}_3}^4, \mathcal{E}_{\mathcal{L}_3}^2$.

alternative map $\mathcal{E}_{\mathcal{L}_{k+1}^k} : P_{k+1} \rightarrow P_k$ by closing a string on the left instead of the right. A planar algebra is then called *spherical* if $\mathcal{E}_{\mathcal{L}_1^0}(p) = \mathcal{E}_{\mathcal{R}_1^0}(p)$ for all $p \in P_1$. The parameter δ is often referred to as the *modulus*. An *annular* (n, k) tangle is a tangle with one internal box of colour n , and whose external box is colour k . Given an annular $(n, 0)$ tangle, its composition with the multiplication tangle defines a bilinear form on P_k . If we take the annular $(n, 0)$ tangle defined by connecting the i th and $(n - i + 1)$ th points together, with all strings to the right of the inner box, then this is known as the *trace* tangle, and its bilinear form satisfies $tr(AB) = tr(BA)$. This follows immediately from the diagram, by simply dragging the second inner box around and above the first inner box. When $\mathbb{K} = \mathbb{R}$ or \mathbb{C} , the planar algebra P is said to be *positive-(semi)definite/(non)degenerate* over a given (bi/conjugate)-linear form if they hold for each P_k .

3.2 Bipartite Graph Planar Algebras

We introduce now the bipartite graph planar algebra (BGPA) [8, 14, 34], and use it to construct algebras isomorphic to sets of upper triangular matrices, then show that they fail to be planar algebras.

Let Γ be a finite bipartite graph, with set of vertices $V^+ \sqcup V^-$, and edges E . Let μ be an arbitrary, non-vanishing function from the vertices to \mathbb{K} , called a *spin function*. Define $K_{n,+}$ to be the vector space with basis of loops of length $2n$ on Γ starting at $v \in V^+$, and similarly for $K_{n,-}$. By the *standard form* of a tangle, we mean a form of the tangle such that there are a minimal number of turning points in the strings, and every turning point and box lie in a separate horizontal region. By turning point, we mean a region of the string that is parallel to the top and bottom of the box containing the string. Given a shaded tangle, a *state*, σ , is an assignment of $v^+ \in V^+$ to unshaded regions, $v^- \in V^-$ to shaded regions and $e \in E$ to strings, such that if a string separates the two regions, then e joins v^+ and v^- . Given a state on a tangle, this then defines a loop of length $2k$ on a box of colour k , with the region with the marked point as the starting point. Alternatively, given a tangle with some number of interior boxes, then choosing some vector paths to insert into the boxes will give a restriction on the possible states. The outcome read from the exterior box is $\sum_{\sigma} \sigma \prod_{\alpha} \mu_{\alpha}$, where α is a turning point on a string and $\mu_{\alpha} := \mu(v_1)/\mu(v_2)$ where v_1 is the vertex assigned to the interior region of α and v_2 is assigned to the exterior region. If $\mathbb{K} = \mathbb{C}$, and $A(\Gamma)$ is the adjacency matrix, then μ^2 is often taken to be the eigenvector of the maximal eigenvalue of $A(\Gamma)$, so that the modulus will be equal to the maximal eigenvalue.

An element λ of $K_{n,\pm}$ can be considered to consist of two paths p, q of length n , one from v_1 to v_2 and one from v_2 to v_1 , denoted $\lambda_{p,q}$. Multiplication of elements is then given as $\lambda_{p,q}\lambda_{r,s} = \delta_{q,\tilde{r}}\lambda_{p,s}$, where \tilde{r} is r in the opposite direction. Defining $\tilde{\lambda}_{p,q} := \lambda_{\tilde{q},\tilde{p}}$, then up to a constant, these elements form a system of matrix units, and hence each $K_{n,\pm}$ is isomorphic to some multi-matrix algebra. This isomorphism is dependant on Γ . If we consider two loops on Γ with different starting points, then it is clear that their product must be zero, hence if $K_{n,\pm} \simeq M_{n_1} \oplus M_{n_2} \oplus \dots \oplus M_{n_i}$, then different starting points for loops correspond to different matrices in this direct sum decomposition. From this we see that $K_{0,\pm} \simeq \bigoplus_{|V^{\pm}|} \mathbb{K}$.

Considering now the embedding tangle $\mathcal{I}\mathcal{R}_k^{k+1}$, inserting a loop $\lambda_{p,q}$ with $p, \tilde{q} : v_1 \rightarrow v_2$ we see that all but one region of the tangle already has assigned vertices. Hence we

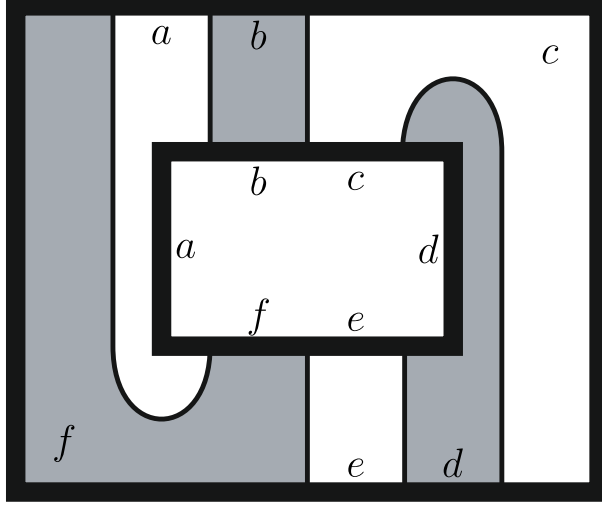

Figure 3.3: Input loop; $abcdefa$, output loop; $\frac{\mu(a)\mu(d)}{\mu(c)\mu(f)} abcdef$

have $\lambda_{p,q} \mapsto \sum_i \lambda_{p+i, \tilde{i}+q}$, where the sum is over all paths i of length one starting at v_2 , and $p+i$ is just concatenation of paths, so $\mathcal{I}_{\mathcal{R}_k}^{k+1} : K_{k,\pm} \rightarrow K_{k+1,\pm}$. Similarly we have $\mathcal{I}_{\mathcal{L}_k}^{k+1} : K_{k,\pm} \rightarrow K_{k+1,\mp}$ given by $\lambda_{p,q} \mapsto \sum_j \lambda_{j+p, q+\tilde{j}}$, summing over all paths j of length one that end at v_1 .

Let Γ be the bipartite graph with $|V^+| = 1$, $|V^-| = n$, then considering just $K_{m,+}$, we see that $\dim K_{0,+} = 1$. For $K_{1,+}$, each loop is uniquely defined by a choice of vertex in V^- , and longer loops are just concatenations of these. Hence we can write a loop in $K_{m,+}$ as a sequence of m vertices in V^- ; $\lambda_{v_1 v_2 \dots v_m}$. From the action of the embedding tangles, we see that $K_{m,+}$ embeds into $K_{m+1,+}$ n ways, hence $\dim K_{m,+} = n^m$. Let $V^- = \{\nu_1, \dots, \nu_n\}$, then we can consider $K_{2,+}$ as the algebra of $n \times n$ matrices with basis entries $e_{i,j}^{2,+} := \lambda_{\nu_i \nu_j}$, where $\lambda_{\nu_i \nu_j}$ is the loop of length four given by $v^+ \rightarrow \nu_i \rightarrow v^+ \rightarrow \nu_j \rightarrow v^+$. Under this consideration, $K_{3,+}$ consists of n copies of $K_{2,+}$ along the diagonal, each copy labelled by ν_j for $\lambda_{\nu_i \nu_j \nu_k} \in K_{3,+}$, $\lambda_{\nu_i \nu_k} \in K_{2,+}$. For $K_{4,+}$, we have $\lambda_{\nu_i \nu_j \nu_k \nu_l} \lambda_{\nu_a \nu_b \nu_c \nu_d} = \delta_{\nu_k \nu_l, \tilde{\nu}_a \tilde{\nu}_b} \lambda_{\nu_i \nu_j \nu_c \nu_d} = \delta_{\nu_k \nu_l, \nu_b \nu_a} \lambda_{\nu_i \nu_j \nu_c \nu_d}$ (as $\tilde{\nu}_a = \nu_a$), therefore $e_{ij,kl}^{4,+} := \lambda_{\nu_j \nu_i \nu_k \nu_l}$, where $ij, kl \in \{11, 12, \dots, 1n, 21, \dots, nn\}$.

Similarly, we have $e_{j^i, j^k}^{3,+} := \lambda_{\nu_i \nu_j \nu_k}$, and the general form is

$$e_{[i_m, i_{m-1}, \dots, i_1], [i_{m+1}, i_{m+2}, \dots, i_{2m}]}^{2m,+} := \lambda_{\nu_{i_1} \dots \nu_{i_m} \nu_{i_{m+1}} \dots \nu_{i_{2m}}}$$

$$e_{[i_{m+1}, i_m, i_{m-1}, \dots, i_1], [i_{m+1}, i_{m+2}, \dots, i_{2m+1}]}^{2m+1,+} := \lambda_{\nu_{i_1} \dots \nu_{i_{2m+1}}}$$

$[a, b, c, \dots, x]$ can be considered a number with digits $abc\dots x$ in base n .

As an example, take $n = 3$ and let $V^- = \{a, b, c\}$, then;

$$\begin{aligned}
K_{1,+} &\simeq \begin{pmatrix} \lambda_a & 0 & 0 \\ 0 & \lambda_b & 0 \\ 0 & 0 & \lambda_c \end{pmatrix}, K_{2,+} \simeq \begin{pmatrix} \lambda_{aa} & \lambda_{ab} & \lambda_{ac} \\ \lambda_{ba} & \lambda_{bb} & \lambda_{bc} \\ \lambda_{ca} & \lambda_{cb} & \lambda_{cc} \end{pmatrix}, \\
K_{3,+} &\simeq \begin{pmatrix} \lambda_{aaa} & \lambda_{aab} & \lambda_{aac} & 0 & 0 & 0 & 0 & 0 & 0 \\ \lambda_{baa} & \lambda_{bab} & \lambda_{bac} & 0 & 0 & 0 & 0 & 0 & 0 \\ \lambda_{caa} & \lambda_{cab} & \lambda_{cac} & 0 & 0 & 0 & 0 & 0 & 0 \\ 0 & 0 & 0 & \lambda_{aba} & \lambda_{abb} & \lambda_{abc} & 0 & 0 & 0 \\ 0 & 0 & 0 & \lambda_{bba} & \lambda_{bbb} & \lambda_{bbc} & 0 & 0 & 0 \\ 0 & 0 & 0 & \lambda_{cba} & \lambda_{cbb} & \lambda_{cbc} & 0 & 0 & 0 \\ 0 & 0 & 0 & 0 & 0 & 0 & \lambda_{aca} & \lambda_{acb} & \lambda_{acc} \\ 0 & 0 & 0 & 0 & 0 & 0 & \lambda_{bca} & \lambda_{bcb} & \lambda_{bcc} \\ 0 & 0 & 0 & 0 & 0 & 0 & \lambda_{cca} & \lambda_{ccb} & \lambda_{ccc} \end{pmatrix}, \\
K_{4,+} &\simeq \begin{pmatrix} \lambda_{aaaa} & \lambda_{aaab} & \lambda_{aaac} & \lambda_{aaba} & \lambda_{aabb} & \lambda_{aabc} & \lambda_{aaca} & \lambda_{aacb} & \lambda_{aacc} \\ \lambda_{baaa} & \lambda_{baab} & \lambda_{baac} & \lambda_{baba} & \lambda_{babb} & \lambda_{babc} & \lambda_{baca} & \lambda_{bacb} & \lambda_{bacc} \\ \lambda_{caaa} & \lambda_{caab} & \lambda_{caac} & \lambda_{caba} & \lambda_{cabb} & \lambda_{cabc} & \lambda_{caca} & \lambda_{cacb} & \lambda_{cacc} \\ \lambda_{abaa} & \lambda_{abab} & \lambda_{abac} & \lambda_{abba} & \lambda_{abbb} & \lambda_{abbc} & \lambda_{abca} & \lambda_{abcb} & \lambda_{abcc} \\ \lambda_{bbaa} & \lambda_{bbab} & \lambda_{bbac} & \lambda_{bbba} & \lambda_{bbbb} & \lambda_{bbbc} & \lambda_{bbca} & \lambda_{bbcb} & \lambda_{bbcc} \\ \lambda_{cbaa} & \lambda_{cbab} & \lambda_{cbac} & \lambda_{cbba} & \lambda_{cbbb} & \lambda_{cbbc} & \lambda_{cbca} & \lambda_{cbcb} & \lambda_{cbcc} \\ \lambda_{acaa} & \lambda_{acab} & \lambda_{acac} & \lambda_{acba} & \lambda_{acbb} & \lambda_{acbc} & \lambda_{acca} & \lambda_{accb} & \lambda_{accc} \\ \lambda_{bcaa} & \lambda_{bcab} & \lambda_{bcac} & \lambda_{bcba} & \lambda_{bcbb} & \lambda_{bcbc} & \lambda_{bccca} & \lambda_{bccb} & \lambda_{bccc} \\ \lambda_{ccaa} & \lambda_{ccab} & \lambda_{ccac} & \lambda_{ccba} & \lambda_{ccbb} & \lambda_{ccbc} & \lambda_{ccca} & \lambda_{cccb} & \lambda_{cccc} \end{pmatrix},
\end{aligned}$$

It follows from this that $K_{2m+1,+} \simeq K_{1,+} \otimes K_{2m,+}$, $K_{2m+2,+} \simeq K_{2,+} \otimes K_{2m,+}$.

$$\bigoplus_n K_{2m,+} \subset K_{2m+1,+}, K_{2m+1,+} \subset K_{2m+2,+}.$$

Continuing on in the general case for Γ with $|V^+| = 1$, $|V^-| = n$, $V^- = \{\nu_1, \dots, \nu_n\}$, we have $\dim K_{0,-} = \dim K_{1,-} = n$. In $K_{2,-}$, loops take the form $\nu_1 \rightarrow \nu^+ \rightarrow \nu_2 \rightarrow \nu^+ \rightarrow \nu_1$, so we can label them as before in terms of $\nu_i \in V^-$; $\lambda_{\nu_i \nu_j (\nu_i)} \in K_{2,-}$, where the first and last vertices must equal to give a loop, so we can omit the last vertex. From this we can see that $\dim K_{2,-} = n^2$, and $\dim K_{3,-} = n^3$, $\lambda_{\nu_i \nu_j \nu_k} \in K_{3,-}$. The (right) embedding maps give $\lambda_{\nu_i \nu_j} \mapsto \lambda_{\nu_i \nu_j \nu_j}$, $\lambda_{\nu_i \nu_j \nu_k} \mapsto \sum_l \lambda_{\nu_i \nu_j \nu_l \nu_k}$. For general $K_{m,-}$, $m \geq 2$ we find $\dim K_{m,-} = n^m$, $\lambda_{\nu_{i_1} \nu_{i_2} \dots \nu_{i_m} \nu_{i_1}} \in K_{m,-}$.

Considering as matrix units, we have:

$$\begin{aligned}\lambda_{\nu_i\nu_j}\lambda_{\nu_k\nu_l} &= \lambda_{\nu_i\nu+\nu_j\nu+\nu_i}\lambda_{\nu_k\nu+\nu_l\nu+\nu_k} = \delta_{\nu_j\nu+\nu_i,\widetilde{\nu_k\nu+\nu_l}}\lambda_{\nu_i\nu+\nu_j\nu+\nu_k} = \delta_{\nu_j\nu+\nu_i,\nu_l\nu+\nu_k}\lambda_{\nu_i\nu+\nu_j\nu+\nu_k} \\ &= \delta_{\nu_i\nu_k}\delta_{\nu_j\nu_l}\lambda_{\nu_i\nu_j}\end{aligned}$$

Hence $e_{ij,ij}^{2,-} := \lambda_{\nu_i\nu_j}$.

$$\lambda_{\nu_i\nu_j\nu_k}\lambda_{\nu_a\nu_b\nu_c} = \delta_{\nu_k\nu_i,\widetilde{\nu_a\nu_b}}\lambda_{\nu_i\nu_j\nu_c} = \delta_{\nu_k\nu_i,\nu_b\nu_a}\lambda_{\nu_i\nu_j\nu_c}. \text{ Therefore } e_{ij,ik}^{3,-} := \lambda_{\nu_i\nu_j\nu_k}.$$

$$\lambda_{\nu_i\nu_j\nu_k\nu_l}\lambda_{\nu_a\nu_b\nu_c\nu_d} = \delta_{\nu_k\nu_l\nu_i,\widetilde{\nu_a\nu_b\nu_c}}\lambda_{\nu_i\nu_j\nu_c\nu_d} = \delta_{\nu_k\nu_l\nu_i,\nu_c\nu_b\nu_a}\lambda_{\nu_i\nu_j\nu_c\nu_d}. \text{ Therefore } e_{ikj,ikl}^{4,-} := \lambda_{\nu_i\nu_j\nu_k\nu_l}.$$

In general we get:

$$\begin{aligned}e_{[i_1,i_{m+1},\dots,i_2],[i_1,i_{m+1},\dots,i_{2m}]}^{2m,-} &:= \lambda_{\nu_{i_1}\dots\nu_{i_{2m}}} \\ e_{[i_1,i_{m+1},\dots,i_2],[i_1,i_{m+2},\dots,i_{2m+1}]}^{2m+1,-} &:= \lambda_{\nu_{i_1}\dots\nu_{i_{2m+1}}}\end{aligned}$$

Take $n = 3$, $V^- = \{a, b, c\}$ again as an example, then:

$$\begin{aligned}K_{0,-} \simeq K_{1,-} &\simeq \begin{pmatrix} \lambda_a & 0 & 0 \\ 0 & \lambda_b & 0 \\ 0 & 0 & \lambda_c \end{pmatrix}, \\ K_{2,-} &\simeq \begin{pmatrix} \lambda_{aa} & 0 & 0 & 0 & 0 & 0 & 0 & 0 & 0 \\ 0 & \lambda_{ab} & 0 & 0 & 0 & 0 & 0 & 0 & 0 \\ 0 & 0 & \lambda_{ac} & 0 & 0 & 0 & 0 & 0 & 0 \\ 0 & 0 & 0 & \lambda_{ba} & 0 & 0 & 0 & 0 & 0 \\ 0 & 0 & 0 & 0 & \lambda_{bb} & 0 & 0 & 0 & 0 \\ 0 & 0 & 0 & 0 & 0 & \lambda_{bc} & 0 & 0 & 0 \\ 0 & 0 & 0 & 0 & 0 & 0 & \lambda_{ca} & 0 & 0 \\ 0 & 0 & 0 & 0 & 0 & 0 & 0 & \lambda_{cb} & 0 \\ 0 & 0 & 0 & 0 & 0 & 0 & 0 & 0 & \lambda_{cc} \end{pmatrix},\end{aligned}$$

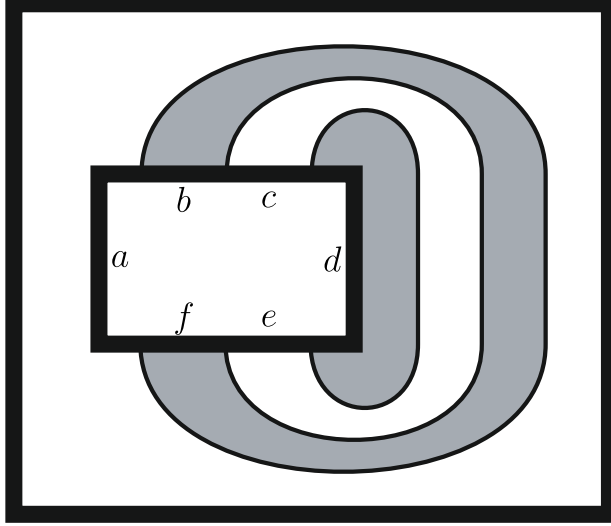

Figure 3.4: For the loop $abcdefa$ to be compatible with the trace tangle, we must have $b = f$ and $c = e$. The output is $\frac{\mu^2(d)}{\mu^2(a)}a$.

$$K_{3,-} \simeq \begin{pmatrix} \lambda_{aaa} & \lambda_{aab} & \lambda_{aac} & 0 & 0 & 0 & 0 & 0 & 0 \\ \lambda_{aba} & \lambda_{abb} & \lambda_{abc} & 0 & 0 & 0 & 0 & 0 & 0 \\ \lambda_{aca} & \lambda_{acb} & \lambda_{acc} & 0 & 0 & 0 & 0 & 0 & 0 \\ 0 & 0 & 0 & \lambda_{baa} & \lambda_{bab} & \lambda_{bac} & 0 & 0 & 0 \\ 0 & 0 & 0 & \lambda_{bba} & \lambda_{bbb} & \lambda_{bbc} & 0 & 0 & 0 \\ 0 & 0 & 0 & \lambda_{bca} & \lambda_{bcb} & \lambda_{bcc} & 0 & 0 & 0 \\ 0 & 0 & 0 & 0 & 0 & 0 & \lambda_{caa} & \lambda_{cab} & \lambda_{cac} \\ 0 & 0 & 0 & 0 & 0 & 0 & \lambda_{cba} & \lambda_{cbb} & \lambda_{cbc} \\ 0 & 0 & 0 & 0 & 0 & 0 & \lambda_{cca} & \lambda_{ccb} & \lambda_{ccc} \end{pmatrix}$$

We can see from the examples that the starting and middle vertices label the algebras in terms of smaller subalgebras, and all other vertices label different elements of these subalgebras. From this, we see that for a general graph, we have:

$$e_{[\nu_{i_1}^\pm, \nu_{i_{m+1}}^\pm, \nu_{j_m}^\mp, \nu_{i_m}^\pm, \dots, \nu_{i_2}^\pm, \nu_{j_1}^\mp], [\nu_{i_1}^\pm, \nu_{i_{m+1}}^\pm, \nu_{j_{m+1}}^\mp, \dots, \nu_{i_{2m}}^\pm, \nu_{j_{2m}}^\mp]}^{2m, \pm} := \lambda_{\nu_{i_1}^\pm \nu_{j_1}^\mp \nu_{i_2}^\pm \dots \nu_{i_{2m}}^\pm \nu_{j_{2m}}^\mp \nu_{i_1}^\pm}$$

$$e_{[\nu_{i_1}^\pm, \nu_{j_{m+1}}^\mp, \nu_{i_{m+1}}^\pm, \nu_{j_m}^\mp, \dots, \nu_{i_2}^\pm, \nu_{j_1}^\mp], [\nu_{i_1}^\pm, \nu_{j_{m+1}}^\mp, \nu_{i_{m+2}}^\pm, \dots, \nu_{j_{2m+1}}^\mp]}^{2m+1, \pm} := \lambda_{\nu_{i_1}^\pm \nu_{j_1}^\mp \nu_{i_2}^\pm \dots \nu_{i_{2m+1}}^\pm \nu_{j_{2m+1}}^\mp \nu_{i_1}^\pm}$$

Note that each pair of vertices (labelling λ) is required to be joined by an edge on the graph. The labelling can easily be extended if a pair of vertices is joined by more than one edge.

There is a natural \mathbb{K} -bilinear form defined on BGPA's from the trace given by $\langle A, B \rangle := \text{tr}(A\tilde{B})$ where $\widetilde{\lambda_{p,q}} := \lambda_{\tilde{q},\tilde{p}}$. However, $\text{tr}(\lambda_{p,q}) = \delta_{p,\tilde{q}}$, so we have;
 $\langle \lambda_{p,q}, \lambda_{r,s} \rangle = \text{tr}(\lambda_{p,q}\widetilde{\lambda_{r,s}}) = \text{tr}(\lambda_{p,q}\lambda_{\tilde{s},\tilde{r}}) = \delta_{q,\tilde{s}}\text{tr}(\lambda_{p,\tilde{r}}) = \delta_{q,\tilde{s}}\delta_{p,r} = \delta_{\lambda_{p,q},\lambda_{r,s}}$, so the loops form an orthogonal basis with this inner product, and hence the inner product is positive definite (for suitable \mathbb{K}).

Let Γ be a graph such that V^+ and V^- are well-ordered. Then define the set of loops on Γ of length $2m$, $U_{m,\pm} := \{\lambda_{p,q} : \tilde{p} \geq q\}$, with the ordering on paths defined as follows. If $x = [\nu_{i_1}, \dots, \nu_{i_{2m}}]$, $y = [\nu_{j_1}, \dots, \nu_{j_{2m}}]$, then $x = y$ if they are equal as paths, and $x > y$ if for some k , we have $\nu_{i_1} = \nu_{j_1}, \dots, \nu_{i_{k-1}} = \nu_{j_{k-1}}, \nu_{i_k} > \nu_{j_k}$. Then $U_{m,\pm}$ is isomorphic to a subalgebra of the upper triangular matrices. If $|V^+| = 1$, $|V^-| = n$, then $U_{2m,+}$ is isomorphic to the $n^m \times n^m$ upper triangular matrices. The loops of the form $\lambda_{p,\tilde{p}}$ correspond to diagonal entries. Note that \sim is not defined on U_m , as if $\lambda_{p,q} \in U_m$, $p \neq \tilde{q}$, then $\widetilde{(\lambda_{p,q})} \notin U_m$. Further, any bilinear form on U_m , such as the trace, that satisfies the cyclic property $f(AB) = f(BA)$, is necessarily degenerate, as on non-diagonal elements, as we have:

$$f(\lambda_{p,q}) = f(\lambda_{p,q}\lambda_{q,q}) = f(\lambda_{q,q}\lambda_{p,q}) = \delta_{q,\tilde{p}}f(\lambda_{q,q}) = 0.$$

Let $\lambda_{p,\tilde{p}} \in U_m$, $p = [\nu_{i_1}, \dots, \nu_{i_{m+1}}]$, with $\nu_{i_{m+1}} > \nu_{i_{m-1}}$, then applying the rotation tangle to $\lambda_{p,\tilde{p}}$, we get the following map in terms of vertices: $\lambda_{[\nu_{i_1}, \dots, \nu_{i_{m+1}}, \dots, \nu_{i_1}]} \mapsto \lambda_{[\nu_{i_2}, \dots, \nu_{i_{m+1}}, \dots, \nu_{i_1}, \nu_{i_2}]} = \lambda_{r,s}$, $r = [\nu_{i_2}, \dots, \nu_{i_{m+1}}, \nu_{i_m}]$, $s = [\nu_{i_m}, \nu_{i_{m-1}}, \dots, \nu_{i_1}, \nu_{i_2}]$. Then we have that $\tilde{r} > s$, so $\lambda_{r,s} \notin U_m$. Hence U_m isn't closed under planar maps.

3.3 Temperley-Lieb Algebras

We introduce now the Temperley-Lieb algebra and its properties, then use the BGPA from the previous section to construct representations of the Temperley-Lieb algebra.

The Temperley-Lieb algebra, TL , is the algebra generated by elements $\{\mathbf{1}, \mathbf{e}_i : i \in \mathbb{N}\}$ satisfying, for $\delta \in \mathbb{K}$;

$$\mathbf{e}_i^2 = \delta \mathbf{e}_i \tag{3.1}$$

$$\mathbf{e}_i \mathbf{e}_{i \pm 1} \mathbf{e}_i = \mathbf{e}_i \tag{3.2}$$

$$\mathbf{e}_i \mathbf{e}_j = \mathbf{e}_j \mathbf{e}_i, |i - j| \geq 2 \tag{3.3}$$

This algebra has an alternative pictorial version, where looking at the subalgebra generated by the first $n-1$ elements, we have the identity given by a box with $2n$ points along the top and bottom, with points i and $2n-i+1$ joined by vertical strings. \mathbf{e}_i is then the diagram with points i and $i+1$ joined together, and $2n-i+1$ and $2n-i$ joined together, with all other points connected vertically. Multiplication of elements is given by vertical concatenation of boxes, extended linearly. Removal of a closed loop from a diagram is equivalent to multiplying the diagram by δ . The dimension of the subalgebra generated by the first n elements, denoted TL_n is given by the n th Catalan number; $\dim TL_n = \frac{1}{n+1} \binom{2n}{n}$. The Temperley-Lieb algebra is the simplest example of a planar algebra, and when $\mathbb{K} = \mathbb{C}$, is positive-definite for $\delta \geq 4$, with conjugate linear-form given by the trace tangle. For the values of $\delta \in \{2 \cos(\frac{\pi}{k}) : 3 \leq k \in \mathbb{N}\}$, TL is positive-semidefinite, and becomes positive-definite when quotiented by the ideal generated by the $k-1$ th *Jones-Wenzl* projection. The Jones-Wenzl projections, denoted \mathbf{f}_n , are defined inductively over \mathbb{K} by:

$$\mathbf{f}_0 = \square, \mathbf{f}_1 = |, \quad (3.4)$$

$$\mathbf{f}_{n+1} = \mathbf{f}_n | - \frac{[n]}{[n+1]} \mathbf{f}_n \mathbf{e}_n \mathbf{f}_n \quad (3.5)$$

Here, $[n]$ denotes the n th *quantum number*, with $[2] = \delta$. See appendix A for further details. \square denotes the empty diagram and $|$ a single vertical string. When $\mathbb{K} = \mathbb{C}$, the quotient $TL_n / \langle \mathbf{f}_k \rangle$ has simple projections $\mathbf{f}_0 \dots \mathbf{f}_{k-1}$, which is often encoded as the bipartite graph A_k , which consists of even vertices $\{0, 2, \dots, k-1\}$, odd vertices $\{1, 3, \dots, k\}$, and edges joining i to $i \pm 1$.

Consider now the subalgebra of the BPGA of A_3 consisting of loops starting at ν_0 . We have:

$$\begin{aligned} \mathcal{A}_0 &= (\lambda_0) \simeq \mathcal{A}_1 = (\lambda_{010}) \\ \mathcal{A}_2 &= \begin{pmatrix} \lambda_{01010} & 0 \\ 0 & \lambda_{01210} \end{pmatrix}, \mathcal{A}_3 = \begin{pmatrix} \lambda_{0101010} & \lambda_{0101210} \\ \lambda_{0121010} & \lambda_{0121210} \end{pmatrix} \\ \mathcal{A}_4 &= \begin{pmatrix} \lambda_{010101010} & \lambda_{010101210} & 0 & 0 \\ \lambda_{012101010} & \lambda_{012101210} & 0 & 0 \\ 0 & 0 & \lambda_{010121010} & \lambda_{010121210} \\ 0 & 0 & \lambda_{012121010} & \lambda_{012121210} \end{pmatrix} \end{aligned}$$

Now consider the tangle with no internal discs and two vertical strings, i.e. the TL identity $\mathbf{1}_2$. Any state on it must assign the vertex 0 to the first region and 1 to the

second region, leaving a choice of the third region. The outcome is then $\lambda_{01010} + \lambda_{01210}$. Similarly for the diagram \mathbf{e}_1 we get $\frac{\mu(1)^2}{\mu(0)^2} \lambda_{01010}$ for some spin function μ . Repeating this for 3-tangles, we find the output of $\mathbf{1}_3$ is $\lambda_{0101010} + \lambda_{0121210}$, for \mathbf{e}_1 is $\frac{\mu(1)^2}{\mu(0)^2} \lambda_{0101010}$, and for \mathbf{e}_2 is $\frac{\mu(0)^2}{\mu(1)^2} \lambda_{0101010} + \frac{\mu(0)\mu(2)}{\mu(1)^2} (\lambda_{0101210} + \lambda_{0121010}) + \frac{\mu(2)^2}{\mu(1)^2} \lambda_{0121210}$. Denoting these outputs respectively as \hat{e}_i , we find that: $\hat{e}_1^2 = \frac{\mu(1)^2}{\mu(0)^2} \hat{e}_1$, $\hat{e}_1 \hat{e}_2 \hat{e}_1 = \hat{e}_1$, $\hat{e}_2 \hat{e}_1 \hat{e}_2 = \hat{e}_2$, $\hat{e}_2^2 = \frac{(\mu(0)^2 + \mu(2)^2)}{\mu(1)^2} \hat{e}_2$. Hence these form a representation of the Temperley-Lieb algebra with $\delta = \frac{\mu(1)^2}{\mu(0)^2} = \frac{(\mu(0)^2 + \mu(2)^2)}{\mu(1)^2}$.

Repeating this construction for 4-boxes gives:

$$\begin{aligned} \hat{\mathbf{1}}_4 &= \sum_{i,j=0}^2 \lambda_{01i1j1i10} & \hat{e}_1 &= \frac{\mu(1)^2}{\mu(0)^2} (\lambda_{010101010} + \lambda_{010121010}) \\ \hat{e}_2 &= \sum_{i,j,k=0}^2 \frac{\mu(i)\mu(k)}{\mu(1)^2} \lambda_{01i1j1k10} & \hat{e}_3 &= \frac{\mu(1)^2}{\mu(0)^2} \lambda_{010101010} + \frac{\mu(1)^2}{\mu(2)^2} \lambda_{012121210} \end{aligned}$$

These again satisfy the TL conditions, apart from $\hat{e}_3^2 = \delta \hat{e}_3$, which is true when $\mu^2(0) = \mu^2(2)$, which then gives $\delta^2 = 2$. Extending this construction to the JW projections, we find: $\hat{f}_0 = \lambda_0$, $\hat{f}_1 = \lambda_{010}$, $\hat{f}_2 = \lambda_{01210}$, $\hat{f}_3 = 0$. Hence this BG-subalgebra is a representation of the TL -algebra at $\delta^2 = 2$.

Repeating this construction using instead A_4 , we get:

$$\begin{aligned} \mathcal{A}_0 &= (\lambda_0) & \mathcal{A}_1 &= (\lambda_{010}) \\ \mathcal{A}_2 &= \begin{pmatrix} \lambda_{01010} & 0 \\ 0 & \lambda_{01210} \end{pmatrix} & \mathcal{A}_3 &= \begin{pmatrix} \lambda_{0101010} & \lambda_{0101210} & 0 \\ \lambda_{0121010} & \lambda_{0121210} & 0 \\ 0 & 0 & \lambda_{0123210} \end{pmatrix} \\ \mathcal{A}_4 &= \begin{pmatrix} \lambda_{010101010} & \lambda_{010101210} & 0 & 0 & 0 \\ \lambda_{012101010} & \lambda_{012101210} & 0 & 0 & 0 \\ 0 & 0 & \lambda_{010121010} & \lambda_{010121210} & \lambda_{010123210} \\ 0 & 0 & \lambda_{012121010} & \lambda_{012121210} & \lambda_{012123210} \\ 0 & 0 & \lambda_{012321010} & \lambda_{012321210} & \lambda_{012323210} \end{pmatrix} \end{aligned}$$

The 3-box TL relations for these are as previous apart from $\hat{\mathbf{1}}_3 = \lambda_{0101010} + \lambda_{0121210} + \lambda_{0123210}$, however for the 4-box elements we now get:

$$\begin{aligned} \hat{\mathbf{1}}_4 &= \sum_{i,j=0}^2 \lambda_{01i1j1i10} + \lambda_{012323210} \\ \hat{e}_3 &= \frac{\mu(1)^2}{\mu(0)^2} \lambda_{010101010} + \sum_{i,j \in \{1,3\}} \frac{\mu(i)\mu(j)}{\mu(2)^2} \lambda_{012i2j210} \end{aligned}$$

Instead of the relation for μ given before, this now satisfies $\hat{e}_3^2 = \delta \hat{e}_3$ if $\delta = \frac{(\mu(1)^2 + \mu(3)^2)}{\mu(2)^2}$.

Considering the 5-box elements, we find;

$$\hat{e}_4 = \frac{\mu(2)^2}{\mu(3)^2} \lambda_{01232323210} + \sum_{i,j,k=0}^2 \frac{\mu(j)\mu(k)}{\mu(1)^2} \lambda_{01i1j1k1i10}$$

which satisfies $\hat{e}_4^2 = \delta \hat{e}_4$ if $\delta = \frac{\mu(2)^2}{\mu(3)^2}$, which gives $\delta^2 = 1 \pm \delta$. Looking at JW projections, $\hat{f}_0, \hat{f}_1, \hat{f}_2$ are the same as previously, however now we have $\hat{f}_3 = \lambda_{0123210}$ and $\hat{f}_4 = 0$.

In general, this construction gives us a representation of TL_n in terms of a BGPA, which can then be identified with a matrix algebra. Viewing as matrices, we have:

A_3, TL_2 ;

$$\hat{\mathbf{1}}_2 = \begin{pmatrix} 1 & 0 \\ 0 & 1 \end{pmatrix} \quad \hat{e}_1 = \begin{pmatrix} \delta & 0 \\ 0 & 0 \end{pmatrix} \quad \hat{f}_2 = \begin{pmatrix} 0 & 0 \\ 0 & 1 \end{pmatrix}$$

TL_3 ;

$$\hat{e}_2 = \begin{pmatrix} \delta^{-1} & \pm\delta^{-1} \\ \pm\delta^{-1} & \delta^{-1} \end{pmatrix}$$

TL_4 ;

$$\hat{e}_1 = \begin{pmatrix} \delta & 0 & 0 & 0 \\ 0 & 0 & 0 & 0 \\ 0 & 0 & \delta & 0 \\ 0 & 0 & 0 & 0 \end{pmatrix} \quad \hat{e}_2 = \begin{pmatrix} \delta^{-1} & \pm\delta^{-1} & 0 & 0 \\ \pm\delta^{-1} & \delta^{-1} & 0 & 0 \\ 0 & 0 & \delta^{-1} & \pm\delta^{-1} \\ 0 & 0 & \pm\delta^{-1} & \delta^{-1} \end{pmatrix} \quad \hat{e}_3 = \begin{pmatrix} \delta & 0 & 0 & 0 \\ 0 & 0 & 0 & 0 \\ 0 & 0 & 0 & 0 \\ 0 & 0 & 0 & \delta \end{pmatrix}$$

A_4, TL_3 ;

$$\hat{e}_2 = \begin{pmatrix} \delta^{-1} & \frac{\mu(0)\mu(2)}{\mu(1)^2} & 0 \\ \frac{\mu(0)\mu(2)}{\mu(1)^2} & \frac{\mu(2)^2}{\mu(1)^2} & 0 \\ 0 & 0 & 0 \end{pmatrix} \quad \hat{f}_3 = \begin{pmatrix} 0 & 0 & 0 \\ 0 & 0 & 0 \\ 0 & 0 & 1 \end{pmatrix}$$

TL_4 ;

$$\hat{e}_2 = \begin{pmatrix} \delta^{-1} & \frac{\mu(0)\mu(2)}{\mu(1)^2} & 0 & 0 & 0 \\ \frac{\mu(0)\mu(2)}{\mu(1)^2} & \frac{\mu(2)^2}{\mu(1)^2} & 0 & 0 & 0 \\ 0 & 0 & \delta^{-1} & \frac{\mu(0)\mu(2)}{\mu(1)^2} & 0 \\ 0 & 0 & \frac{\mu(0)\mu(2)}{\mu(1)^2} & \frac{\mu(2)^2}{\mu(1)^2} & 0 \\ 0 & 0 & 0 & 0 & 0 \end{pmatrix} \quad \hat{e}_3 = \begin{pmatrix} \delta & 0 & 0 & 0 & 0 \\ 0 & 0 & 0 & 0 & 0 \\ 0 & 0 & 0 & 0 & 0 \\ 0 & 0 & 0 & \frac{\mu(1)^2}{\mu(2)^2} & \frac{\mu(1)\mu(3)}{\mu(2)^2} \\ 0 & 0 & 0 & \frac{\mu(1)\mu(3)}{\mu(2)^2} & \frac{\mu(3)^2}{\mu(2)^2} \end{pmatrix}$$

For a general choice of A_n , the restriction on δ becomes:

$$\delta = \frac{\mu(1)^2}{\mu(0)^2} = \frac{\mu(0)^2 + \mu^2(2)}{\mu(1)^2} = \dots = \frac{\mu(i-1)^2 + \mu(i+1)^2}{\mu(i)^2} = \dots = \frac{\mu(n-2)^2}{\mu(n-1)^2}$$

Denoting the equation for the restricted δ for A_n by $\hat{\delta}_n$, this gives:

$$\begin{aligned}\hat{\delta}_2 &= \delta^{-1} \\ \hat{\delta}_3 &= (\delta - \hat{\delta}_2)^{-1} = (\delta - \delta^{-1})^{-1} \\ \hat{\delta}_4 &= (\delta - \hat{\delta}_3)^{-1} = (\delta - (\delta - \delta^{-1})^{-1})^{-1} \\ \hat{\delta}_n &= (\delta - \hat{\delta}_{n-1})^{-1}\end{aligned}$$

3.4 Temperley-Lieb Category

The Temperley-Lieb algebra has an alternative categorical description as a tensor category, that is sometimes more useful to work with [13, 66].

Let $[m, n]$ be the set of boxes with m points along their top edge, n points along their bottom edge, and $(m+n)/2$ non-intersecting strings joining pairs of these points. Let $\mathbb{K}[m, n]$ be the free vector space over a field \mathbb{K} with $[m, n]$ as its basis.

The *Temperley-Lieb Category*, \mathcal{TL}_δ , is the category whose objects are the natural numbers \mathbb{N} , and whose morphisms $Hom_{\mathbb{K}}(m, n) := \mathbb{K}[m, n]$. Composition of morphisms is given by concatenation of compatible boxes, i.e. if $a \in [m, n]$ and $b \in [x, y]$, then $ba \in [m, y]$ if $n = x$. The objects have an obvious grading given by whether they are an odd or even number of points. There is a functor, called the tensor map, $\otimes : \mathcal{TL}_\delta \rightarrow \mathcal{TL}_\delta$ defined on objects by $m \otimes n := m + n$. For morphisms, $a \otimes b$ is the $(m+x, n+y)$ -box given by adjoining b to the right of a . This is extended bilinearly to all morphisms, giving $\mathbb{K}[m, n] \otimes \mathbb{K}[x, y] \subset \mathbb{K}[m+x, n+y]$. The parameter $\delta \in \mathbb{K}$ defines a relation such that if a morphism contains a closed loop, then removing this loop multiplies the morphism by δ . The Temperley-Lieb algebra from the previous section can be redefined in terms of this category as $TL_n := End_{\mathbb{K}}[n]$, as $End_{\mathbb{K}}[n]$ is simply the \mathbb{K} -vector space with the set of n -point TL diagrams as its basis. Planar maps on TL can be rewritten as combinations of the tensor map and $Hom_{\mathbb{K}}(m, n)$.

By considering the idempotent completion of this category, we find the simple objects of

\mathcal{TL}_δ are the Jones-Wenzl projections, which are identity maps on themselves. As objects, we will denote these projections by X_n , and as morphisms by f_n , so we have:

$f_n = \mathbf{1}_{X_n} \in \text{End}_{\mathbb{K}}(X_n)$, $X_n \in \text{Ob}(\mathcal{TL}_\delta)$, $\dim \text{End}_{\mathbb{K}}(X_n) = 1$. The object X_0 is the unit object, and satisfies $X_0 \otimes Y = Y \otimes X_0 = Y$ for any object Y . The simple objects satisfy: $X_n \otimes X_1 \simeq X_{n-1} \oplus X_{n+1}$ [21].

Many examples of fusion and modular tensor categories can be constructed from \mathcal{TL}_δ . The structure of such categories is partially encoded by their *fusion rules* [7, 59].

Let $\{X_k\} \in \text{Ob}(\mathcal{C})$ be the set of simple objects, then for any $A_i \in \text{Ob}(\mathcal{C})$, we have:

$$A_i \otimes A_j = \bigoplus_k N_{ij}^k X_k \quad (3.6)$$

with $N_{ij}^k \in \mathbb{N}$.

Some of the simplest examples of fusion rules are the *Semion rules*, with simple objects $\{\mathbf{1}, Y\}$, and fusion rules:

$$\mathbf{1} \otimes Y = Y \otimes \mathbf{1} = Y, \quad Y \otimes Y = \mathbf{1} \quad (3.7)$$

the *Fibonacci rules*, with simple objects $\{\mathbf{1}, X\}$, and fusion rules:

$$\mathbf{1} \otimes X = X \otimes \mathbf{1} = X, \quad X \otimes X = \mathbf{1} \oplus X \quad (3.8)$$

and the *Ising rules*, with simple objects $\{\mathbf{1}, Y, \Psi\}$, and fusion rules:

$$Y \otimes Y = \mathbf{1}, \quad \Psi \otimes Y = Y \otimes \Psi = \Psi, \quad \Psi \otimes \Psi = \mathbf{1} \oplus Y \quad (3.9)$$

We give examples of the construction of these using the Temperley-Lieb category with notation as above. Given a fusion rule and a set of simple objects, each construction will follow the same outline:

- Find isomorphism maps $\Phi_{ij} : X_i \otimes X_j \rightarrow \bigoplus_k N_{ij}^k X_k$ such that $\Phi_{ij}^{-1} \Phi_{ij} = \mathbf{1}_{X_i \otimes X_j}$,

$$\Phi_{ij} \Phi_{ij}^{-1} = \mathbf{1}_{\bigoplus_k N_{ij}^k X_k} := \bigoplus_k \bigoplus_{N_{ij}^k} \mathbf{1}_{X_k}$$
- These maps will generally rely on relations given by some quotient of \mathcal{TL}_δ by a Jones-Wenzl projection.
- Use these maps to construct the maps for the fusion of three objects, i.e. $\Phi_{(ij)k}$ and $\Phi_{i(jk)}$. These will have some linear relation that we solve for either by use of the pentagon equation, or by capping off of diagrams.
- Similarly construct braiding relations for objects and solve the hexagon equation for them.

- Find the twist relation for each simple objects using its identity, or again by capping off of diagrams.
- Use these results to construct the S and T matrices, then see if they satisfy identities 2.3, 2.4, and 2.5. This allows a way to check if the derived relations are consistent with the fusion rules.

The pentagon and hexagon equations, and twist identity, are given in section 2.5.

In each construction, the identity object, $\mathbf{1}$, is the Jones-Wenzl projection X_0 . It follows from this that for any object, tensoring with the identity object is strict, i.e. $X_0 \otimes Y = Y \otimes X_0 = Y$, for any object Y . For the associativity, braiding, and twist, we only need to consider the simple objects, as the solutions for any other objects will be based on their solutions. The associativity maps for three objects can be constructed as follows:

$$\Phi_{(ij)k} = \begin{array}{c} \begin{array}{ccc} i & j & k \\ | & | & | \\ \boxed{\Phi_{ij}^m} & \boxed{\mathbf{1}_{X_k}} & \\ \diagdown & / & \\ m & & \end{array} \\ \boxed{\Phi_{mk}} \\ | \end{array}, \quad \Phi_{i(jk)} = \begin{array}{c} \begin{array}{ccc} i & j & k \\ | & | & | \\ \boxed{\mathbf{1}_{X_i}} & \boxed{\Phi_{jk}^n} & \\ \diagdown & / & \\ & n & \end{array} \\ \boxed{\Phi_{in}} \\ | \end{array}$$

where Φ_{ij}^m is a component of the isomorphism map Φ_{ij} giving a map $\Phi_{ij}^m : X_i \otimes X_j \rightarrow X_m$.

The braid and twist relations will be based on the following:

$$\begin{array}{c} \begin{array}{cc} i & j \\ \diagdown & / \\ & \diagdown & / \\ & & k \end{array} \\ \boxed{\Phi_{ji}^k} \\ | \end{array} = r \begin{array}{c} \begin{array}{cc} i & j \\ | & | \\ \boxed{\Phi_{ij}^k} \\ | \end{array} \\ k \end{array}, \quad \begin{array}{c} | \\ \boxed{\mathbf{1}_{X_i}} \\ \text{loop} \end{array} = t \begin{array}{c} | \\ \boxed{\mathbf{1}_{X_i}} \\ | \end{array}$$

where $r, t \in \mathbb{K}$.

3.4.1 The Semion Construction

An example of the Semion fusion rules can be constructed by setting $\mathbf{1} := X_0$ and $Y := X_1$ with the additional conditions that $X_2 = 0$, which requires $f_2 = 0$ and $[3] = 0$. This gives

that $Hom(1, 1) = \mathbb{K}f_0$ and $Hom(Y, Y) = \mathbb{K}f_1$. As an object, Y will be represented by a single point, i.e. the start or end point of a string.

Let \tilde{V} denote the transpose vector of V with all diagram entries reflected about the horizontal. From the condition that $[3] = 0$, we have:

$$\begin{aligned} 1 + [3] &= [2]^2 \\ [2]^2 &= \delta^2 = 1 \\ \delta &= \pm 1 \end{aligned}$$

Using the condition $f_2 = 0$, we have:

$$\begin{aligned} f_2 &:= \left| \right| -\delta^{-1} \begin{array}{c} \cup \\ \cap \end{array} \\ f_2 = 0 &\rightarrow \left| \right| = \delta \begin{array}{c} \cup \\ \cap \end{array} \end{aligned}$$

where we used $\delta^2 = 1$. Taking account of this relation, we want to find an isomorphism map for the semion fusion rule $Y \otimes Y = 1$. Given our choice of objects, this is then a map:

$$\begin{aligned} \Phi &: X_1 \otimes X_1 \rightarrow X_0 \\ \tilde{\Phi}\Phi &= \mathbf{1}_{X_1 \otimes X_1} = f_1 \otimes f_1 \\ \Phi\tilde{\Phi} &= \mathbf{1}_{X_0} = f_0 \end{aligned}$$

We have:

$$\begin{aligned} \Phi &:= \delta^{\frac{1}{2}} \begin{array}{c} \cup \end{array} \\ \tilde{\Phi}\Phi &= \delta \begin{array}{c} \cup \\ \cap \end{array} = \left| \right| = \mathbf{1}_{X_1 \otimes X_1} \\ \Phi\tilde{\Phi} &= \delta \begin{array}{c} \bigcirc \end{array} = \delta^2 \mathbf{1}_{X_0} = \mathbf{1}_{X_0} \end{aligned}$$

For associativity, as $Y \otimes Y \otimes Y \simeq \mathbf{1}$, we can take the associativity map $\alpha_{Y,Y,Y} : (Y \otimes Y) \otimes Y \rightarrow Y \otimes (Y \otimes Y)$ to be:

$$\delta^{\frac{1}{2}} \left| \cup \right. = a \delta^{\frac{1}{2}} \left| \cup \right.$$

for some $a \in \mathbb{K}$. All other associativity maps contain $\mathbf{1}$, and so are strict. Solving the pentagon equation with this, we have:

$$\begin{array}{ccccc} ((Y \otimes Y) \otimes Y) \otimes Y & \xrightarrow{\alpha_{Y,Y,Y}} & (Y \otimes (Y \otimes Y)) \otimes Y & \xrightarrow{\alpha_{Y,(Y \otimes Y),Y}} & Y \otimes ((Y \otimes Y) \otimes Y) \\ \cup \quad \cup & = & a \quad \cup & = & a \quad \cup \\ \parallel \downarrow \alpha_{(Y \otimes Y),Y,Y} & & & & \parallel \downarrow \alpha_{Y,Y,Y} \\ (Y \otimes Y) \otimes (Y \otimes Y) & \xrightarrow{\alpha_{Y,Y,(Y \otimes Y)}} & & & a^2 \quad \cup \quad \cup \\ & = & & & Y \otimes (Y \otimes (Y \otimes Y)) \end{array}$$

Hence $a^2 = 1$. For the braiding, as $Y \otimes Y \simeq \mathbf{1}$, the braiding must be a multiple of Φ .

Hence let:

$$\delta = r \cup$$

Note that any braiding with $\mathbf{1}$ is trivial, as $\mathbf{1} \otimes A = A \otimes \mathbf{1} = A$, for any object A .

Solving the hexagon equation, we have:

$$\begin{array}{ccccccc} (Y \otimes Y) \otimes Y & \xrightarrow{\alpha_{Y,Y,Y}} & Y \otimes (Y \otimes Y) & \xrightarrow{c_{Y,(Y \otimes Y)}} & (Y \otimes Y) \otimes Y & \xrightarrow{\alpha_{Y,Y,Y}} & Y \otimes (Y \otimes Y) \\ \cup \quad | & = & a \quad | \quad \cup & = & a \quad \delta & = & a \quad \delta & = & a^2 \quad \delta \\ \downarrow c_{Y,Y} & & & & & & & & \parallel \\ (Y \otimes Y) \otimes Y & \xrightarrow{\alpha_{Y,Y,Y}} & Y \otimes (Y \otimes Y) & \xrightarrow{c_{Y,Y}} & Y \otimes (Y \otimes Y) & & & & \\ r^{-1} \delta \quad | & = & r^{-1} \delta \quad | & = & ar^{-1} \delta & = & ar^{-2} \delta \end{array}$$

Hence $r^{-2} = a$. Solving the second hexagon equation gives $r^2 = a$. As this is the Temperley-Lieb category, we can assume closure under planar relations. Hence by capping off the associativity relation, we get:

$$\cup \quad | = a \quad | \quad \cup \rightarrow \bigcirc \quad | = a \quad \int \cup$$

Hence $a = \delta$. For the twist, as Y is simple, $\theta_Y : Y \rightarrow Y$ must be a multiple of f_1 , hence we have:

$$\left(\text{twist} \right) = t \quad |$$

Solving the twist relation, we have:

$$\left(\text{parallel lines} \right) = \left(\text{twist with loop} \right) = \left(\text{twist with loop} \right) = t^2 \left(\text{twist} \right) = r^2 t^2 \left(\text{parallel lines} \right)$$

Hence $t = r^{-1}$. We have then the relations:

$$\alpha_{Y,Y,Y}(Y \otimes Y) \otimes Y = aY \otimes (Y \otimes Y)$$

$$c_{Y,Y}(Y \otimes Y) = r(Y \otimes Y)$$

$$\theta_Y(Y) = tY$$

with constraints:

$$\delta^2 = 1, \quad a = \delta, \quad r^2 = a, \quad t = r^{-1}$$

These will have a solution if we take \mathbb{K} as a cyclotomic field, i.e. an extension of \mathbb{Q} by some root of unity [10]. Letting $\mathbb{K} = \mathbb{Q}[i]$, this gives four possible choices for r , with the

other variables dependent on the choice of r :

$$\begin{aligned} r = \pm 1 = t, & & \delta = a = 1 \\ r = \pm i = -t, & & \delta = a = -1 \end{aligned}$$

For the S and T matrices, we first have $d(1) = 1$, $d(X) = \delta$, so $\text{Dim}(\text{Semion}) = 2$. Similarly we get $\xi(\text{Semion}) = \frac{(1+r^{-1})}{\sqrt{2}}$, which requires $r \neq -1$ to be non-zero. Hence:

$$S = \frac{1}{\sqrt{2}} \begin{pmatrix} 1 & r^2 \\ r^2 & r^2 \end{pmatrix} \quad T = \frac{2^{\frac{1}{6}}}{(1+r^{-1})^{\frac{1}{3}}} \begin{pmatrix} 1 & 0 \\ 0 & r^{-1} \end{pmatrix} \quad (3.10)$$

3.4.2 The Ising Construction

An example of the Ising fusion rules is constructed by setting $\mathbf{1} := X_0$, $\Psi := X_1$ and $Y := X_2$ with the additional condition that $X_3 = 0$, which requires $f_3 = 0$ and $[4] = 0$. Clearly $\text{Hom}(X_0, X_0) = \mathbb{K}f_0$, $\text{Hom}(X_1, X_1) = \mathbb{K}f_1$, $\text{Hom}(X_2, X_2) = \mathbb{K}f_2$. Using the identity for quantum numbers from Appendix A gives:

$$[4] = [2]([3] - 1)$$

$$[4] = [2]([2]^2 - 2)$$

As we want $[2] \neq 0$, we must have $[2]^2 = 2$, as well $[3] = 1$. Hence $\delta^2 = 2$, and $\frac{[2]}{[3]} = \delta$.

From the condition $f_3 = 0$, we have:

$$\begin{aligned} f_3 &= \begin{array}{c} \text{---} \\ | \\ \boxed{f_2} \\ | \\ \text{---} \end{array} \Big| -\delta \begin{array}{c} \text{---} \\ | \\ \boxed{f_2} \\ | \\ \text{---} \\ \text{---} \\ | \\ \boxed{f_2} \\ | \\ \text{---} \end{array} \\ f_3 = 0 &\rightarrow \begin{array}{c} \text{---} \\ | \\ \boxed{f_2} \\ | \\ \text{---} \end{array} \Big| = \delta \begin{array}{c} \text{---} \\ | \\ \boxed{f_2} \\ | \\ \text{---} \\ \text{---} \\ | \\ \boxed{f_2} \\ | \\ \text{---} \end{array} \end{aligned}$$

From this, by considering $(f_2 \otimes f_2)(f_3 \otimes 1)(f_2 \otimes f_2)$, we then get:

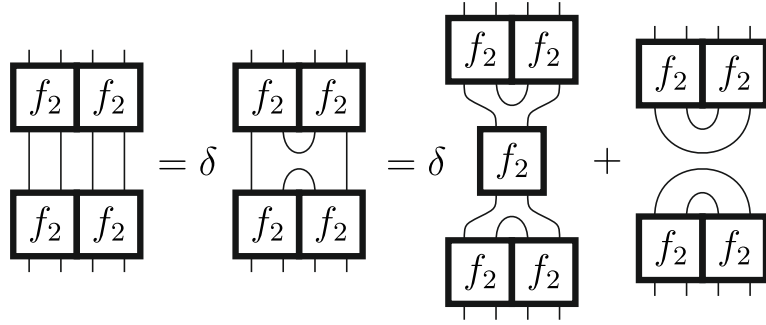

However, from this we have:

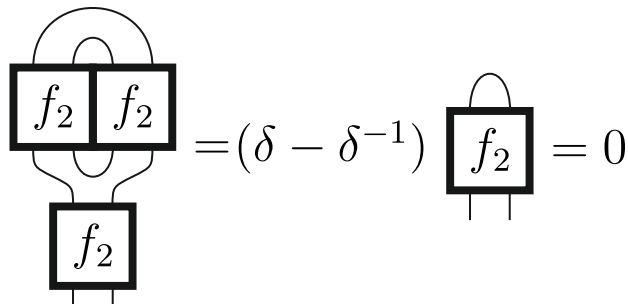
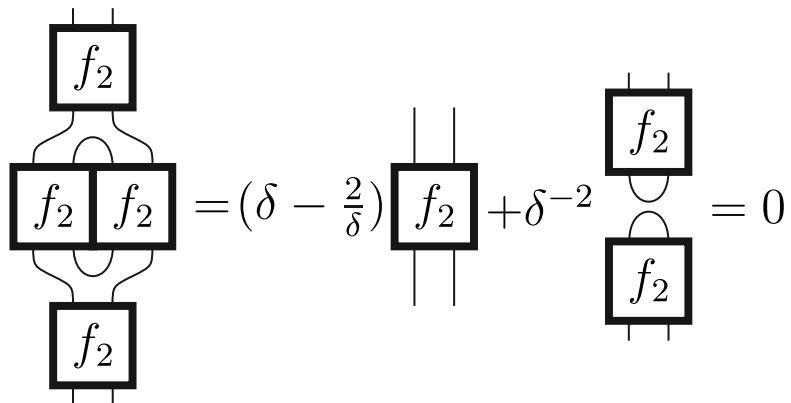
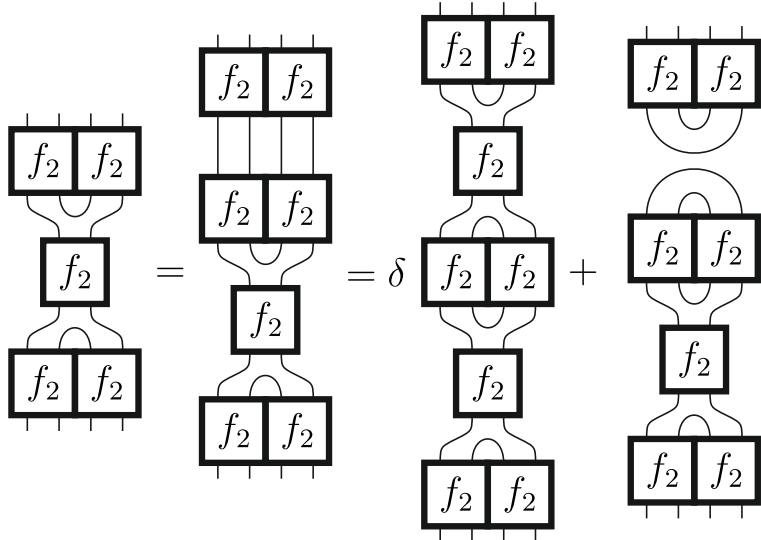

Hence this gives:

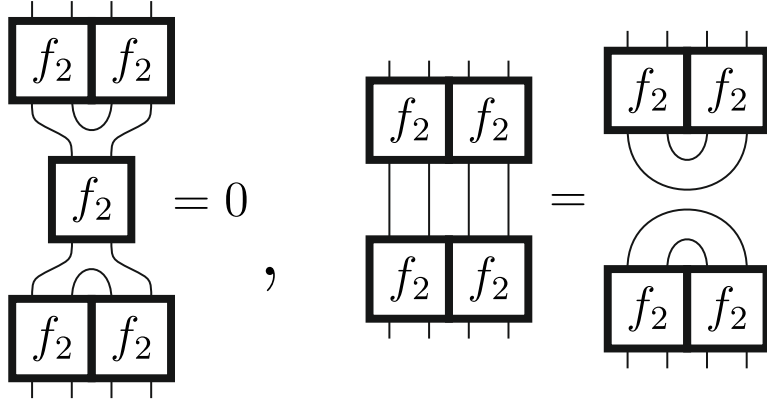

Using this, for the fusion rule $Y \otimes Y \simeq \mathbf{1}$, we have:

$$\begin{aligned}
 \Phi_{YY} &:= \text{Diagram with two } f_2 \text{ boxes and a loop} \\
 \tilde{\Phi}_{YY} \Phi_{YY} &= \text{Diagram with two } f_2 \text{ boxes and a loop} = \text{Diagram with two } f_2 \text{ boxes and two vertical lines} = \mathbf{1}_{X_2 \otimes X_2} \\
 \Phi_{YY} \tilde{\Phi}_{YY} &= \text{Diagram with two } f_2 \text{ boxes and a loop} = (\delta^2 - 1) \mathbf{1}_{X_0} = \mathbf{1}_{X_0}
 \end{aligned}$$

Hence $\Phi_{YY} : Y \otimes Y \rightarrow \mathbf{1}$ is the isomorphism map for $Y \otimes Y \simeq \mathbf{1}$. For the fusion rule $\Psi \otimes \Psi \simeq \mathbf{1} \oplus Y$, we have:

$$\begin{aligned}
\Phi_{\Psi\Psi} &:= \left(\begin{array}{c} \frac{1}{\sqrt{\delta}} \text{cup} \\ \boxed{f_2} \end{array} \right) \\
\Phi_{\Psi\Psi} \tilde{\Phi}_{\Psi\Psi} &= \left(\begin{array}{c} \frac{1}{\sqrt{\delta}} \text{cup} \\ \boxed{f_2} \end{array} \right) \left(\begin{array}{c} \frac{1}{\sqrt{\delta}} \text{cap}, \boxed{f_2} \end{array} \right) = \left(\begin{array}{cc} \delta^{-1} \text{circle} & \boxed{f_2} \\ \boxed{f_2} & \boxed{f_2} \end{array} \right) = \begin{pmatrix} \mathbf{1}_{X_0} & 0 \\ 0 & \mathbf{1}_{X_2} \end{pmatrix} \\
\tilde{\Phi}_{\Psi\Psi} \Phi_{\Psi\Psi} &= \left(\begin{array}{c} \frac{1}{\sqrt{\delta}} \text{cap}, \boxed{f_2} \end{array} \right) \left(\begin{array}{c} \frac{1}{\sqrt{\delta}} \text{cup} \\ \boxed{f_2} \end{array} \right) = \delta^{-1} \text{cup} + \boxed{f_2} = \left| \right| = \mathbf{1}_{X_1 \otimes X_1}
\end{aligned}$$

Hence $\Phi_{\Psi\Psi}$ is the isomorphism map for $\Psi \otimes \Psi \simeq \mathbf{1} \oplus Y$. Finally, for the fusion rules $Y \otimes \Psi \simeq \Psi \otimes Y \simeq \Psi$, we have:

$$\begin{aligned}
\Phi_{Y\Psi} &:= \left(\begin{array}{c} \delta^{\frac{1}{2}} \boxed{f_2} \\ \text{cup} \end{array} \right) \\
\tilde{\Phi}_{Y\Psi} \Phi_{Y\Psi} &= \left(\begin{array}{c} \delta^{\frac{1}{2}} \boxed{f_2} \\ \text{cap} \end{array} \right) \left(\begin{array}{c} \delta^{\frac{1}{2}} \boxed{f_2} \\ \text{cup} \end{array} \right) = \delta \begin{array}{c} \boxed{f_2} \\ \text{cup} \\ \boxed{f_2} \end{array} = \boxed{f_2} \left| \right| = \mathbf{1}_{X_2 \otimes X_1} \\
\Phi_{Y\Psi} \tilde{\Phi}_{Y\Psi} &= \left(\begin{array}{c} \delta^{\frac{1}{2}} \boxed{f_2} \\ \text{cup} \end{array} \right) \left(\begin{array}{c} \delta^{\frac{1}{2}} \boxed{f_2} \\ \text{cap} \end{array} \right) = \delta \boxed{f_2} \left| \right| = \mathbf{1}_{\Psi}
\end{aligned}$$

For the second case, we first need the following:

$$\begin{aligned}
\left| \begin{array}{c} \boxed{f_2} \\ \hline \end{array} \right| &= \delta \left| \begin{array}{c} \boxed{f_2} \\ \boxed{f_2} \\ \hline \end{array} \right| \\
\left| \begin{array}{c} \boxed{f_2} \\ \hline \end{array} \right| + \frac{1}{\delta} \left| \begin{array}{c} \cup \\ \cap \\ \hline \end{array} \right| - \frac{1}{\delta} \left| \begin{array}{c} \cap \\ \cup \\ \hline \end{array} \right| &= \left| \begin{array}{c} \boxed{f_2} \\ \hline \end{array} \right| \\
\delta \left| \begin{array}{c} \boxed{f_2} \\ \boxed{f_2} \\ \hline \end{array} \right| + \frac{1}{\delta} \left| \begin{array}{c} \cup \\ \cap \\ \hline \end{array} \right| - \frac{1}{\delta} \left| \begin{array}{c} \cap \\ \cup \\ \hline \end{array} \right| &= \delta \left| \begin{array}{c} \boxed{f_2} \\ \boxed{f_2} \\ \hline \end{array} \right| \\
\rightarrow \left| \begin{array}{c} \boxed{f_2} \\ \hline \end{array} \right| &= \delta \left| \begin{array}{c} \boxed{f_2} \\ \boxed{f_2} \\ \hline \end{array} \right|
\end{aligned}$$

Using this, we then have:

$$\begin{aligned}
\Phi_{\Psi Y} &:= \left(\delta^{\frac{1}{2}} \left| \begin{array}{c} \boxed{f_2} \\ \hline \end{array} \right| \right) \\
\tilde{\Phi}_{\Psi Y} \Phi_{\Psi Y} &= \left(\delta^{\frac{1}{2}} \left| \begin{array}{c} \boxed{f_2} \\ \hline \end{array} \right| \right) \left(\delta^{\frac{1}{2}} \left| \begin{array}{c} \boxed{f_2} \\ \hline \end{array} \right| \right) = \delta \left| \begin{array}{c} \boxed{f_2} \\ \boxed{f_2} \\ \hline \end{array} \right| = \left| \begin{array}{c} \boxed{f_2} \\ \hline \end{array} \right| = \mathbf{1}_{X_1 \otimes X_2} \\
\Phi_{\Psi Y} \tilde{\Phi}_{\Psi Y} &= \left(\delta^{\frac{1}{2}} \left| \begin{array}{c} \boxed{f_2} \\ \hline \end{array} \right| \right) \left(\delta^{\frac{1}{2}} \left| \begin{array}{c} \boxed{f_2} \\ \hline \end{array} \right| \right) = \delta \left| \begin{array}{c} \boxed{f_2} \\ \hline \end{array} \right| = \mathbf{1}_{\Psi}
\end{aligned}$$

Hence we have found isomorphism maps for the Ising fusion rules.

The next step is to solve the pentagon equation for the associativity maps.

We have $Y \otimes Y \otimes Y \simeq \mathbf{1}$, so there must be some $a_0 \in \mathbb{K}$ such that $\Phi_{(YY)Y} = a_0 \Phi_{Y(YY)}$.

Diagrammatically, this is:

$$\left| \begin{array}{c} \boxed{f_2} \quad \boxed{f_2} \quad \boxed{f_2} \\ \hline \end{array} \right| = a_0 \left| \begin{array}{c} \boxed{f_2} \quad \boxed{f_2} \quad \boxed{f_2} \\ \hline \end{array} \right|$$

Solving the pentagon equation with this gives $a_0^2 = 1$, However, by capping off the top we get:

The diagram shows two boxes, each containing three f_2 labels. Each box has three vertical wires extending from its top and bottom. The left box has a cap on the top-left wire and a cap on the bottom-right wire. The right box has a cap on the top-right wire and a cap on the bottom-left wire. The two boxes are separated by an equals sign and a scalar a_0 .

Hence $a_0 = 1$ and we have:

$$\Phi_{(YY)Y} = \Phi_Y(YY)$$

Indeed this technique of "capping off" diagrams is very useful, and gives us a much simpler alternative to solving the pentagon equation. Once given the isomorphism maps for $(A \otimes B) \otimes C$ and $A \otimes (B \otimes C)$ for objects A , B , and C , we can cap off the maps to find relations between them.

As $\Psi \otimes \Psi \otimes \Psi \simeq \Psi \oplus \Psi$, the situation is more complicated, and the associativity relation will be in terms of a matrix. The isomorphism maps for $(\Psi \otimes \Psi) \otimes \Psi$ and $\Psi \otimes (\Psi \otimes \Psi)$ can be constructed from previously given isomorphism maps as follows:

$$\begin{aligned} \Phi_{(\Psi\Psi)\Psi} : (\Psi \otimes \Psi) \otimes \Psi &\rightarrow \Psi \oplus \Psi, & \Phi_{(\Psi\Psi)\Psi} &= (f_1 \oplus \Phi_{\Psi Y})(\Phi_{\Psi\Psi} \otimes f_1) \\ \Phi_{\Psi(\Psi\Psi)} : \Psi \otimes (\Psi \otimes \Psi) &\rightarrow \Psi \oplus \Psi, & \Phi_{\Psi(\Psi\Psi)} &= (f_1 \oplus \Phi_{Y\Psi})(f_1 \otimes \Phi_{\Psi\Psi}) \end{aligned}$$

Diagrammatically, these are:

The diagram shows two equations. The first is $\Phi_{(\Psi\Psi)\Psi} = \left(\begin{array}{c} \frac{1}{\sqrt{\delta}} \text{ (cup)} \\ \sqrt{\delta} \text{ (box } f_2 \text{)} \end{array} \right)$. The second is $\Phi_{\Psi(\Psi\Psi)} = \left(\begin{array}{c} \frac{1}{\sqrt{\delta}} \text{ (cup)} \\ \sqrt{\delta} \text{ (box } f_2 \text{)} \end{array} \right)$. The diagrams use vertical lines, cups, and boxes labeled f_2 to represent the maps.

For the associativity map between $(\Psi \otimes \Psi) \otimes \Psi$ and $\Psi \otimes (\Psi \otimes \Psi)$, we can write it as:

$$\Phi_{(\Psi\Psi)\Psi} = \begin{pmatrix} a_1 & a_2 \\ a_3 & a_4 \end{pmatrix} \Phi_{\Psi(\Psi\Psi)}$$

Diagrammatically this is:

$$\frac{1}{\sqrt{\delta}} \left| \begin{array}{c} \cup \\ \hline \end{array} \right| = \frac{a_1}{\sqrt{\delta}} \left| \begin{array}{c} \cup \\ \hline \end{array} \right| + a_2 \sqrt{\delta} \left| \begin{array}{c} \boxed{f_2} \\ \hline \end{array} \right|$$

$$\sqrt{\delta} \left| \begin{array}{c} \boxed{f_2} \\ \hline \end{array} \right| = \frac{a_3}{\sqrt{\delta}} \left| \begin{array}{c} \cup \\ \hline \end{array} \right| + a_4 \sqrt{\delta} \left| \begin{array}{c} \boxed{f_2} \\ \hline \end{array} \right|$$

Applying $\cap|$ to these, we get:

$$\frac{1}{\sqrt{\delta}} \left| \begin{array}{c} \bigcirc \\ \hline \end{array} \right| = \frac{a_1}{\sqrt{\delta}} \left| \begin{array}{c} \cup \\ \hline \end{array} \right| + a_2 \sqrt{\delta} \left| \begin{array}{c} \boxed{f_2} \\ \hline \end{array} \right|, \quad \sqrt{\delta} \left| \begin{array}{c} \boxed{f_2} \\ \hline \end{array} \right| = \frac{a_3}{\sqrt{\delta}} \left| \begin{array}{c} \cup \\ \hline \end{array} \right| + a_4 \sqrt{\delta} \left| \begin{array}{c} \boxed{f_2} \\ \hline \end{array} \right|$$

Hence $\sqrt{\delta} = \frac{a_1}{\sqrt{\delta}} + \frac{a_2}{\sqrt{\delta}}$, $a_4 = -a_3$. Applying $|\cap$ to these, we get:

$$\frac{1}{\sqrt{\delta}} \left| \begin{array}{c} \cup \\ \hline \end{array} \right| = \frac{a_1}{\sqrt{\delta}} \left| \begin{array}{c} \bigcirc \\ \hline \end{array} \right| + a_2 \sqrt{\delta} \left| \begin{array}{c} \boxed{f_2} \\ \hline \end{array} \right|, \quad \sqrt{\delta} \left| \begin{array}{c} \boxed{f_2} \\ \hline \end{array} \right| = \frac{a_3}{\sqrt{\delta}} \left| \begin{array}{c} \bigcirc \\ \hline \end{array} \right| + a_4 \sqrt{\delta} \left| \begin{array}{c} \boxed{f_2} \\ \hline \end{array} \right|$$

Hence $\delta a_1 = 1$, $a_3 = \delta$. Combining the two solutions gives:

$$a_1 = \frac{1}{\delta}, \quad a_2 = \frac{1}{\delta}, \quad a_3 = \frac{1}{\delta}, \quad a_4 = \frac{-1}{\delta}$$

Hence we have the associativity relation:

$$\Phi_{(\Psi\Psi)\Psi} = \begin{pmatrix} \delta^{-1} & \delta^{-1} \\ \delta^{-1} & -\delta^{-1} \end{pmatrix} \Phi_{\Psi(\Psi\Psi)}$$

Next, we want to find the associativity relations for $Y \otimes Y \otimes \Psi \simeq Y \otimes \Psi \otimes Y \simeq \Psi \otimes Y \otimes Y \simeq \Psi$.

For this we need the following isomorphism maps:

$$\begin{aligned} \Phi_{(Y Y)\Psi} : (Y \otimes Y) \otimes \Psi &\rightarrow \Psi, & \Phi_{Y(Y\Psi)} : Y \otimes (Y \otimes \Psi) &\rightarrow \Psi \\ \Phi_{(Y\Psi)Y} : (Y \otimes \Psi) \otimes Y &\rightarrow \Psi, & \Phi_{Y(\Psi Y)} : Y \otimes (\Psi \otimes Y) &\rightarrow \Psi \\ \Phi_{(\Psi Y)Y} : (\Psi \otimes Y) \otimes Y &\rightarrow \Psi, & \Phi_{\Psi(Y Y)} : \Psi \otimes (Y \otimes Y) &\rightarrow \Psi \end{aligned}$$

Again, these can be constructed from the previously given isomorphism maps for two objects. For example, $\Phi_{(Y\Psi)Y}$ is given by $\Phi_{\Psi Y}(\Phi_{Y\Psi} \otimes f_2)$. Diagrammatically, the maps are:

$$\begin{aligned} \Phi_{(YY)\Psi} &= \left(\begin{array}{c} \boxed{f_2} \quad \boxed{f_2} \\ \text{---} \\ \text{---} \end{array} \right), & \Phi_{Y(Y\Psi)} &= \left(\delta \begin{array}{c} \boxed{f_2} \quad \boxed{f_2} \\ \text{---} \\ \text{---} \end{array} \right), & \Phi_{(Y\Psi)Y} &= \left(\delta \begin{array}{c} \boxed{f_2} \quad \boxed{f_2} \\ \text{---} \\ \text{---} \end{array} \right) \\ \Phi_{Y(\Psi Y)} &= \left(\delta \begin{array}{c} \boxed{f_2} \quad \boxed{f_2} \\ \text{---} \\ \text{---} \end{array} \right), & \Phi_{(\Psi Y)Y} &= \left(\delta \begin{array}{c} \boxed{f_2} \quad \boxed{f_2} \\ \text{---} \\ \text{---} \end{array} \right), & \Phi_{\Psi(Y Y)} &= \left(\begin{array}{c} \boxed{f_2} \quad \boxed{f_2} \\ \text{---} \\ \text{---} \end{array} \right) \end{aligned}$$

The associativity relations must take the following form:

$$\Phi_{(YY)\Psi} = a_5 \Phi_{Y(Y\Psi)}, \quad \Phi_{(Y\Psi)Y} = a_6 \Phi_{Y(\Psi Y)}, \quad \Phi_{(\Psi Y)Y} = a_7 \Phi_{\Psi(Y Y)}$$

where $a_5, a_6, a_7 \in \mathbb{K}$. By applying $\mathfrak{m}|$ to the isomorphism maps, we get:

$$a_5 = 1, \quad a_6 = 1$$

By applying $|\mathfrak{m}$ to the maps, we get:

$$a_7 = 1$$

Hence we have:

$$\Phi_{(YY)\Psi} = \Phi_{Y(Y\Psi)}, \quad \Phi_{(Y\Psi)Y} = \Phi_{Y(\Psi Y)}, \quad \Phi_{(\Psi Y)Y} = \Phi_{\Psi(Y Y)}$$

Finally, we want to find the associativity maps for $\Psi \otimes \Psi \otimes Y \simeq \Psi \otimes Y \otimes \Psi \simeq Y \otimes \Psi \otimes \Psi \simeq Y \oplus \mathbf{1}$. Diagrammatically, the isomorphism maps are:

$$\begin{aligned} \Phi_{(\Psi\Psi)Y} &= \left(\begin{array}{c} \frac{1}{\sqrt{\delta}} \text{---} \boxed{f_2} \\ \text{---} \\ \boxed{f_2} \quad \boxed{f_2} \end{array} \right), & \Phi_{\Psi(\Psi Y)} &= \left(\begin{array}{c} \boxed{f_2} \\ \text{---} \\ \sqrt{\delta} \text{---} \boxed{f_2} \\ \text{---} \\ \boxed{f_2} \end{array} \right), & \Phi_{(\Psi Y)\Psi} &= \left(\begin{array}{c} \boxed{f_2} \\ \text{---} \\ \sqrt{\delta} \text{---} \boxed{f_2} \\ \text{---} \\ \boxed{f_2} \end{array} \right), \\ \Phi_{\Psi(Y\Psi)} &= \left(\begin{array}{c} \boxed{f_2} \\ \text{---} \\ \sqrt{\delta} \text{---} \boxed{f_2} \\ \text{---} \\ \boxed{f_2} \end{array} \right), & \Phi_{(Y\Psi)\Psi} &= \left(\begin{array}{c} \boxed{f_2} \\ \text{---} \\ \sqrt{\delta} \text{---} \boxed{f_2} \\ \text{---} \\ \boxed{f_2} \end{array} \right), & \Phi_{Y(\Psi\Psi)} &= \left(\begin{array}{c} \frac{1}{\sqrt{\delta}} \boxed{f_2} \text{---} \\ \text{---} \\ \boxed{f_2} \quad \boxed{f_2} \end{array} \right) \end{aligned}$$

Although the image of these maps is two-dimensional, the image objects aren't isomorphic, and so any associativity map won't mix between them. The associativity relations

must then be of the form:

$$\begin{aligned}\Phi_{(\Psi\Psi)Y} &= \begin{pmatrix} 0 & a_8 \\ a_9 & 0 \end{pmatrix} \Phi_{\Psi(\Psi Y)}, & \Phi_{(\Psi Y)\Psi} &= \begin{pmatrix} a_{10} & 0 \\ 0 & a_{11} \end{pmatrix} \Phi_{\Psi(Y\Psi)}, \\ \Phi_{(Y\Psi)\Psi} &= \begin{pmatrix} 0 & a_{12} \\ a_{13} & 0 \end{pmatrix} \Phi_{Y(\Psi\Psi)}\end{aligned}$$

where the first and third matrices are non-diagonal to account for $\Phi_{(\Psi\Psi)Y}$ and $\Phi_{Y(\Psi\Psi)}$ having the map to $\mathbf{1}$ on the bottom instead of the top. By applying $|\cap|$ to the isomorphism maps, we get:

$$a_8 = 1, \quad a_{10} = 1, \quad a_{11} = -1$$

By applying $|\cap|$ to the maps, we get:

$$a_9 = 1, \quad a_{12} = 1, \quad a_{13} = 1$$

Hence we have:

$$\begin{aligned}\Phi_{(\Psi\Psi)Y} &= \begin{pmatrix} 0 & 1 \\ 1 & 0 \end{pmatrix} \Phi_{\Psi(\Psi Y)}, & \Phi_{(\Psi Y)\Psi} &= \begin{pmatrix} 1 & 0 \\ 0 & -1 \end{pmatrix} \Phi_{\Psi(Y\Psi)}, \\ \Phi_{(Y\Psi)\Psi} &= \begin{pmatrix} 0 & 1 \\ 1 & 0 \end{pmatrix} \Phi_{Y(\Psi\Psi)}\end{aligned}$$

Hence we have found all the associativity constraints for our construction of the Ising fusion rules.

The next step now is to find braiding relations.

Any braiding with $\mathbf{1}$ will be trivial, so we only need to consider the cases $Y \otimes Y$, $\Psi \otimes \Psi$, and $\Psi \otimes Y$. Starting with $Y \otimes Y$, diagrammatically, we must have:

$$\begin{array}{c} \text{Diagram 1} \\ \text{Diagram 2} \\ \text{Diagram 3} \end{array} = r_0 \begin{array}{c} \text{Diagram 3} \end{array}$$

Solving the hexagon equation with this, we have:

$$\begin{array}{ccccccc}
(Y \otimes Y) \otimes Y & \xrightarrow{\alpha_{Y,Y,Y}} & Y \otimes (Y \otimes Y) & \xrightarrow{c_{Y,(Y \otimes Y)}} & (Y \otimes Y) \otimes Y & \xrightarrow{\alpha_{Y,Y,Y}} & Y \otimes (Y \otimes Y) \\
\downarrow c_{Y,Y} & & & & & & \\
r_0^{-1} & & r_0^{-1} & & & & r_0^{-2}
\end{array}$$

Hence $r_0^{-2} = 1$. Solving the second hexagon equation gives $r_0^2 = 1$.

For $\Psi \otimes \Psi$, the braiding relation is:

$$\begin{array}{c}
\text{Diagram 1} \\
= r_1 \text{Diagram 2}
\end{array}, \quad
\begin{array}{c}
\text{Diagram 3} \\
= r_2 \text{Diagram 4}
\end{array}$$

For $\Psi \otimes Y$ and $Y \otimes \Psi$, the relations are:

$$\begin{array}{c}
\text{Diagram 1} \\
= r_3 \text{Diagram 2}
\end{array}, \quad
\begin{array}{c}
\text{Diagram 3} \\
= r_4 \text{Diagram 4}
\end{array}$$

To Solve the hexagon equation for $\Psi \otimes \Psi$, we have to consider two cases, $\Psi \otimes \Psi \otimes \Psi \rightarrow \mathbf{1}$, and $\Psi \otimes \Psi \otimes \Psi \rightarrow \Psi$. For the first case, we have:

$$\begin{array}{c}
(\Psi \otimes \Psi) \otimes \Psi \xrightarrow{\alpha_{\Psi, \Psi, \Psi}} \delta^{-1} \left| \begin{array}{c} \Psi \otimes (\Psi \otimes \Psi) \\ \downarrow \\ \text{cup} \end{array} \right. + \left| \begin{array}{c} \Psi \otimes (\Psi \otimes \Psi) \\ \downarrow \\ \text{box } f_2 \end{array} \right. \xrightarrow{c_{\Psi, (\Psi \otimes \Psi)}} \delta^{-1} \left| \begin{array}{c} (\Psi \otimes \Psi) \otimes \Psi \\ \downarrow \\ \text{cross} \end{array} \right. + r_3^{-1} \left| \begin{array}{c} (\Psi \otimes \Psi) \otimes \Psi \\ \downarrow \\ \text{box } f_2 \end{array} \right. \xrightarrow{\alpha_{\Psi, \Psi, \Psi}} \frac{(1+r_3^{-1})}{\delta^2} \left| \begin{array}{c} \Psi \otimes (\Psi \otimes \Psi) \\ \downarrow \\ \text{cup} \end{array} \right. + \frac{(1-r_3^{-1})}{\delta} \left| \begin{array}{c} \Psi \otimes (\Psi \otimes \Psi) \\ \downarrow \\ \text{box } f_2 \end{array} \right. \\
\downarrow c_{\Psi, \Psi} \\
(\Psi \otimes \Psi) \otimes \Psi \xrightarrow{\alpha_{\Psi, \Psi, \Psi}} r_1^{-1} \left| \begin{array}{c} \Psi \otimes (\Psi \otimes \Psi) \\ \downarrow \\ \text{cross} \end{array} \right. = \frac{r_1^{-1}}{\delta} \left| \begin{array}{c} \Psi \otimes (\Psi \otimes \Psi) \\ \downarrow \\ \text{cup} \end{array} \right. + r_1^{-1} \left| \begin{array}{c} \Psi \otimes (\Psi \otimes \Psi) \\ \downarrow \\ \text{box } f_2 \end{array} \right. \xrightarrow{c_{\Psi, \Psi}} \frac{r_1^{-2}}{\delta} \left| \begin{array}{c} \Psi \otimes (\Psi \otimes \Psi) \\ \downarrow \\ \text{cross} \end{array} \right. + r_1^{-1} r_2^{-1} \left| \begin{array}{c} \Psi \otimes (\Psi \otimes \Psi) \\ \downarrow \\ \text{box } f_2 \end{array} \right.
\end{array}$$

For the second case, we have:

$$\begin{array}{c}
(\Psi \otimes \Psi) \otimes \Psi \xrightarrow{\alpha_{\Psi, \Psi, \Psi}} \frac{1}{\delta^2} \left| \begin{array}{c} \Psi \otimes (\Psi \otimes \Psi) \\ \downarrow \\ \text{cup} \end{array} \right. - \frac{1}{\delta} \left| \begin{array}{c} \Psi \otimes (\Psi \otimes \Psi) \\ \downarrow \\ \text{box } f_2 \end{array} \right. \xrightarrow{c_{\Psi, (\Psi \otimes \Psi)}} \frac{1}{\delta^2} \left| \begin{array}{c} (\Psi \otimes \Psi) \otimes \Psi \\ \downarrow \\ \text{cross} \end{array} \right. - \frac{r_3^{-1}}{\delta} \left| \begin{array}{c} (\Psi \otimes \Psi) \otimes \Psi \\ \downarrow \\ \text{box } f_2 \end{array} \right. \xrightarrow{\alpha_{\Psi, \Psi, \Psi}} \frac{(1-r_3^{-1})}{\delta^3} \left| \begin{array}{c} \Psi \otimes (\Psi \otimes \Psi) \\ \downarrow \\ \text{cup} \end{array} \right. + \frac{(1+r_3^{-1})}{\delta^2} \left| \begin{array}{c} \Psi \otimes (\Psi \otimes \Psi) \\ \downarrow \\ \text{box } f_2 \end{array} \right. \\
\downarrow c_{\Psi, \Psi} \\
(\Psi \otimes \Psi) \otimes \Psi \xrightarrow{\alpha_{\Psi, \Psi, \Psi}} r_2^{-1} \left| \begin{array}{c} \Psi \otimes (\Psi \otimes \Psi) \\ \downarrow \\ \text{cross} \end{array} \right. = \frac{r_2^{-1}}{\delta^2} \left| \begin{array}{c} \Psi \otimes (\Psi \otimes \Psi) \\ \downarrow \\ \text{cup} \end{array} \right. - \frac{r_2^{-1}}{\delta} \left| \begin{array}{c} \Psi \otimes (\Psi \otimes \Psi) \\ \downarrow \\ \text{box } f_2 \end{array} \right. \xrightarrow{c_{\Psi, \Psi}} \frac{r_1^{-1} r_2^{-1}}{\delta^2} \left| \begin{array}{c} \Psi \otimes (\Psi \otimes \Psi) \\ \downarrow \\ \text{cross} \end{array} \right. - \frac{r_2^{-2}}{\delta} \left| \begin{array}{c} \Psi \otimes (\Psi \otimes \Psi) \\ \downarrow \\ \text{box } f_2 \end{array} \right.
\end{array}$$

Hence we have:

$$\begin{array}{ll}
\delta^{-2}(1+r_3^{-1}) = \delta^{-1} r_1^{-2}, & \delta^{-1}(1-r_3^{-1}) = r_1^{-1} r_2^{-1}, \\
\delta^{-3}(1-r_3^{-1}) = \delta^{-2} r_1^{-1} r_2^{-1}, & \delta^{-2}(1+r_3^{-1}) = -\delta^{-1} r_2^{-2}
\end{array}$$

Solving the second hexagon equation similarly, we get:

$$\begin{array}{ll}
\delta^{-2}(1+r_3) = \delta^{-1} r_1^2, & \delta^{-1}(1-r_3) = r_1 r_2, \\
\delta^{-3}(1-r_3) = \delta^{-2} r_1 r_2, & \delta^{-2}(1+r_3) = -\delta^{-1} r_2^2
\end{array}$$

We can simplify these to give r_2 and r_3 in terms of r_1 and δ , as well as a polynomial that r_1 must satisfy.

For the braiding on $\Psi \otimes Y$, instead of solving the hexagon equation, we use the following:

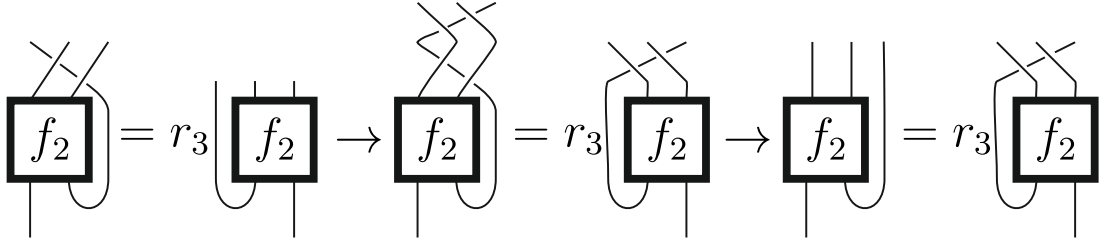

Hence $r_3 = r_4$. The braiding solutions are then:

$$r_0^2 = 1, \quad r_2 = \frac{\delta}{r_1} - r_1, \quad r_3 = r_4 = \delta r_1^2 - 1, \quad r_1^4 - \delta r_1^2 + 1 = 0$$

Finally we want to find the twist on Ψ and Y . These are:

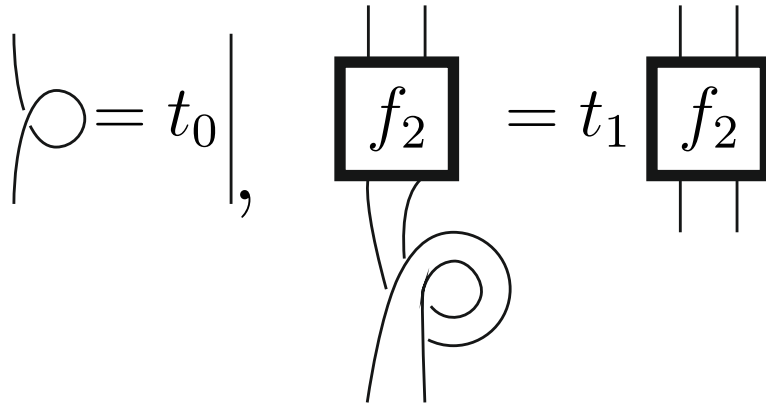

We can solve for these by capping off braiding relations. For Ψ , applying $\cap|$ we have:

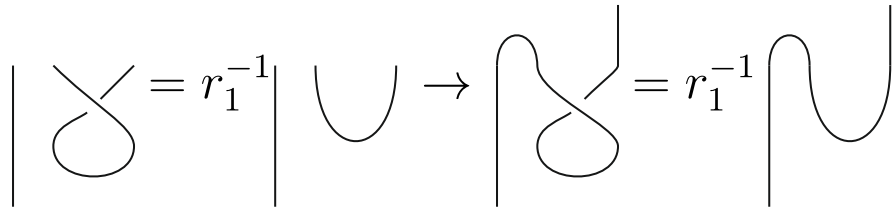

Hence $t_0 = r_1^{-1}$. For Y , applying $\cap||$ we have:

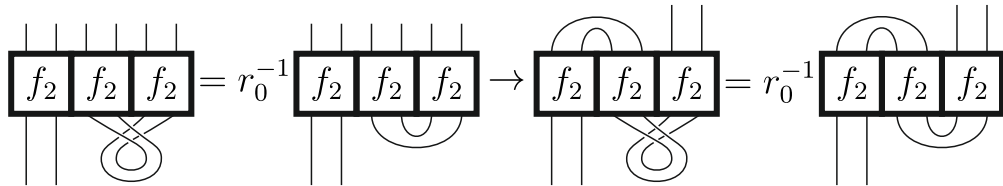

Hence we have $t_1 = r_0^{-1}$. However, using the twist identity, (2.5), for $Y \otimes \Psi$, we have that $t_1 = r_3^{-2}$. Hence $t_1^{-1} = r_0 = r_3^2 = \delta^2 r_1^4 - 2\delta r_1^2 + 1 = r_1^4 - \delta r_1^2 = -1$. We have then found constraints for all associativity, braidings, and twists.

The constraints we have found on associativity, braiding, and twists, have a solution when $\mathbb{K} = \mathbb{Q}[\zeta_{16}]$, where ζ_{16} is a sixteenth root of unity, and there are eight possible solutions to the constraints:

$$\begin{array}{llll}
\delta = \sqrt{2}, & r_1 = e^{\frac{\pm i\pi}{8}} : & r_2 = e^{\frac{\mp 3i\pi}{8}}, & r_3 = \pm i \\
& r_1 = e^{\frac{\pm 7i\pi}{8}} : & r_2 = e^{\frac{\mp 5i\pi}{8}}, & r_3 = \mp i \\
\delta = -\sqrt{2}, & r_1 = e^{\frac{\pm 3i\pi}{8}} : & r_2 = e^{\frac{\pm 7i\pi}{8}}, & r_3 = \mp i \\
& r_1 = e^{\frac{\pm 5i\pi}{8}} : & r_2 = e^{\frac{\pm i\pi}{8}}, & r_3 = \mp i
\end{array}$$

For the S and T matrices, we find first that $d(1) = 1$, $d(Y) = 1$, and $d(\Psi) = \delta$, so $\text{Dim}(\text{Ising}) = 4$. The first row and column of the S -matrix are just $d(Y)$, as braiding with the identity is trivial. By symmetry, we have $\tilde{S}_{Y,\Psi} = \tilde{S}_{\Psi,Y} = -\delta$, as well as $\tilde{S}_{Y,Y} = 1$. For $\tilde{S}_{\Psi,\Psi}$, we need to sum over the two fusion outcomes, giving $\tilde{S}_{\Psi,\Psi} = r_1^2 + r_2^2 = 0$. For the T -matrix, we have $\xi(\text{Ising}) = \theta_\Psi$. Hence:

$$S = \frac{1}{2} \begin{pmatrix} 1 & \delta & 1 \\ \delta & 0 & -\delta \\ 1 & -\delta & 1 \end{pmatrix} \quad T = \begin{pmatrix} (\theta_\Psi)^{-\frac{1}{3}} & 0 & 0 \\ 0 & (\theta_\Psi)^{\frac{2}{3}} & 0 \\ 0 & 0 & -(\theta_\Psi)^{-\frac{1}{3}} \end{pmatrix} \quad (3.11)$$

3.4.3 The Fibonacci and Yang-Lee Construction

An example of the Fibonacci model can be constructed similarly, by setting $\mathbf{1} := X_0$ and $X := X_2$, with the condition $X_4 = 0$, which requires $f_4 = 0$ and $[5] = 0$. For the condition $[5] = 0$, this gives:

$$[3]^2 = [3] + 1, \quad [3]^2 = [2]^2, \quad [4] = \frac{[2]}{[3]}, \quad [4]^2 = 1$$

We only consider the case $[2] = [3]$, which gives us two values for $\delta = \frac{1 \pm \sqrt{5}}{2}$, as well as $[4] = 1$.

The condition $f_4 = 0$ gives:

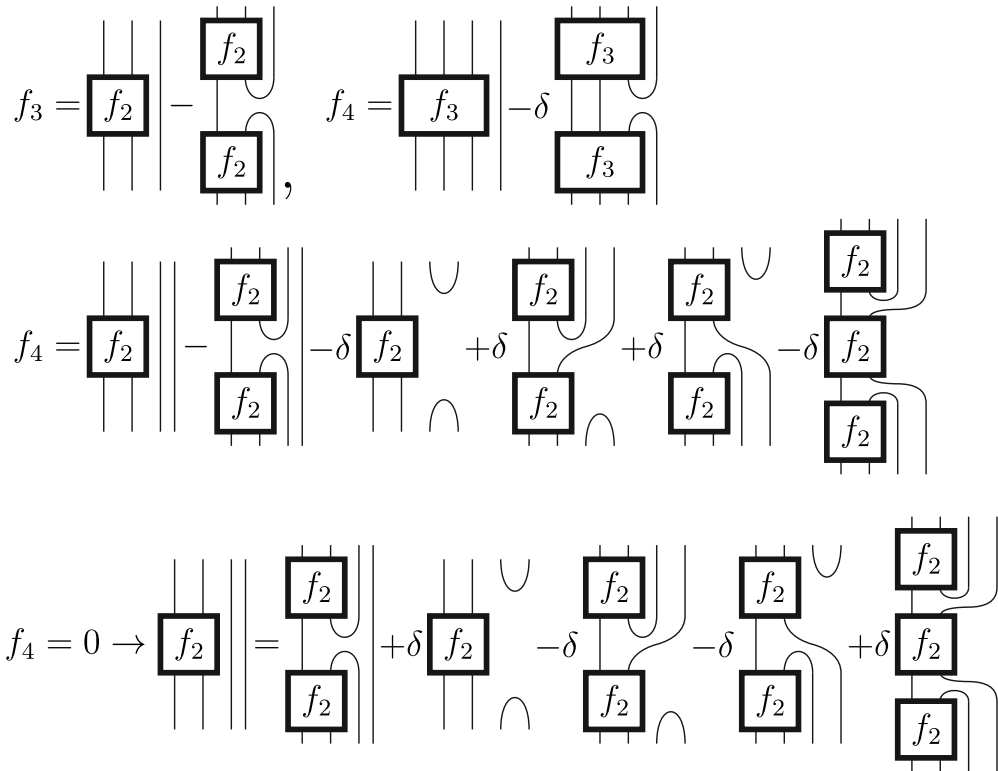

By considering $(f_2 \otimes f_2)f_4)(f_2 \otimes f_2)$ we then have:

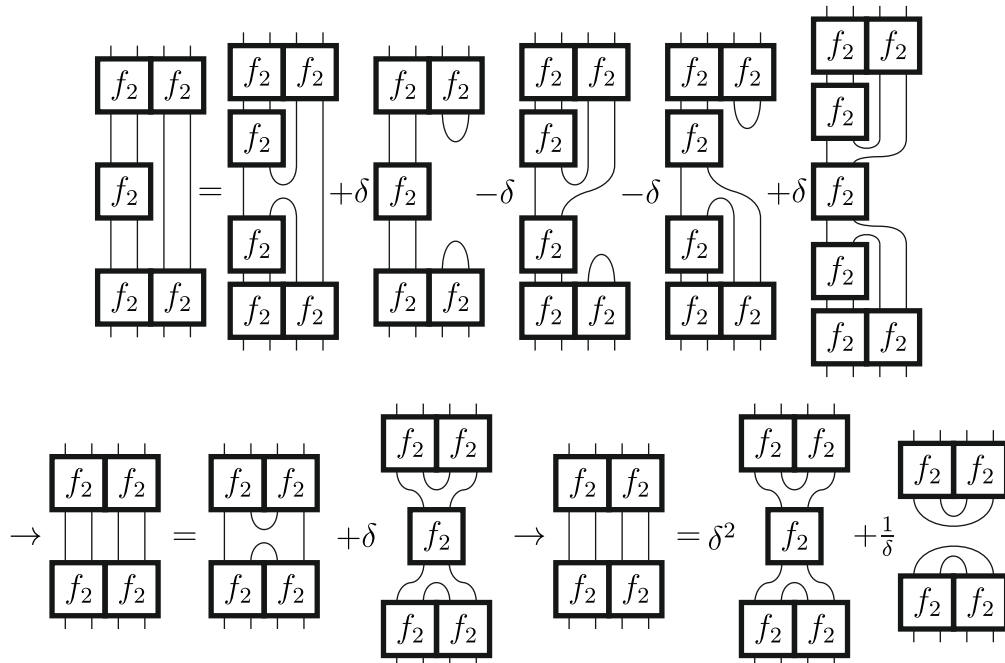

We want to give an isomorphism map for the Fibonacci fusion rules. This is $\Phi_{XX} : X \otimes X \rightarrow \mathbf{1} \oplus X$. We have:

$$\begin{aligned}
\Phi_{XX} &:= \left(\begin{array}{c} \frac{1}{\sqrt{\delta}} \begin{array}{|c|c|} \hline f_2 & f_2 \\ \hline \end{array} \\ \delta \begin{array}{|c|c|} \hline f_2 & f_2 \\ \hline \end{array} \\ f_2 \end{array} \right) \\
\Phi_{XX} \tilde{\Phi}_{XX} &= \left(\begin{array}{c} \frac{1}{\sqrt{\delta}} \begin{array}{|c|c|} \hline f_2 & f_2 \\ \hline \end{array} \\ \delta \begin{array}{|c|c|} \hline f_2 & f_2 \\ \hline \end{array} \\ f_2 \end{array} \right) \left(\begin{array}{c} \frac{1}{\sqrt{\delta}} \begin{array}{|c|c|} \hline f_2 & f_2 \\ \hline \end{array}, \delta \begin{array}{|c|c|} \hline f_2 & f_2 \\ \hline \end{array} \end{array} \right) = \left(\begin{array}{c} \frac{1}{\delta} \begin{array}{|c|c|} \hline f_2 & f_2 \\ \hline \end{array} \quad \sqrt{\delta} \begin{array}{|c|c|} \hline f_2 & f_2 \\ \hline \end{array} \\ \sqrt{\delta} \begin{array}{|c|c|} \hline f_2 & f_2 \\ \hline \end{array} \quad \delta^2 \begin{array}{|c|c|} \hline f_2 & f_2 \\ \hline \end{array} \\ f_2 \end{array} \right) = \begin{pmatrix} \mathbf{1}_{X_0} & 0 \\ 0 & \mathbf{1}_{X_2} \end{pmatrix} \\
\tilde{\Phi}_{XX} \Phi_{XX} &= \left(\begin{array}{c} \frac{1}{\sqrt{\delta}} \begin{array}{|c|c|} \hline f_2 & f_2 \\ \hline \end{array}, \delta \begin{array}{|c|c|} \hline f_2 & f_2 \\ \hline \end{array} \end{array} \right) \left(\begin{array}{c} \frac{1}{\sqrt{\delta}} \begin{array}{|c|c|} \hline f_2 & f_2 \\ \hline \end{array} \\ \delta \begin{array}{|c|c|} \hline f_2 & f_2 \\ \hline \end{array} \\ f_2 \end{array} \right) = \delta^2 \begin{array}{|c|c|} \hline f_2 & f_2 \\ \hline \end{array} + \frac{1}{\delta} \begin{array}{|c|c|} \hline f_2 & f_2 \\ \hline \end{array} = \begin{array}{|c|c|} \hline f_2 & f_2 \\ \hline \end{array} = \mathbf{1}_{X_2 \otimes X_2}
\end{aligned}$$

Given this map, we can construct isomorphism maps for $X \otimes X \otimes X \simeq X \oplus \mathbf{1} \oplus X$.

These maps are:

$$\Phi_{(XX)X} : (X \otimes X) \otimes X \rightarrow X \oplus \mathbf{1} \oplus X, \quad \Phi_{X(XX)} : X \otimes (X \otimes X) \rightarrow X \oplus \mathbf{1} \oplus X$$

They are given by $\Phi_{(XX)X} = (1 \otimes \Phi_{XX})(\Phi_{XX} \otimes f_2)$, $\Phi_{X(XX)} = (\Phi_{XX} \otimes 1)(f_2 \otimes \Phi_{XX})$.

Diagrammatically, these maps are:

$$\begin{aligned}
\Phi_{(XX)X} &= \left(\begin{array}{c} \frac{1}{\sqrt{\delta}} \begin{array}{|c|c|c|} \hline f_2 & f_2 & f_2 \\ \hline \end{array} \\ \sqrt{\delta} \begin{array}{|c|c|c|} \hline f_2 & f_2 & f_2 \\ \hline \end{array} \\ f_2 \end{array} \right) \\
\Phi_{X(XX)} &= \left(\begin{array}{c} \frac{1}{\sqrt{\delta}} \begin{array}{|c|c|c|} \hline f_2 & f_2 & f_2 \\ \hline \end{array} \\ \sqrt{\delta} \begin{array}{|c|c|c|} \hline f_2 & f_2 & f_2 \\ \hline \end{array} \\ \delta^2 \begin{array}{|c|c|c|} \hline f_2 & f_2 & f_2 \\ \hline \end{array} \\ f_2 \end{array} \right)
\end{aligned}$$

We to find the associativity constraints for these maps. This takes the form:

$$\Phi_{(XX)X} = \begin{pmatrix} a_0 & 0 & a_1 \\ 0 & a_2 & 0 \\ a_3 & 0 & a_4 \end{pmatrix} \Phi_{X(XX)}$$

We have:

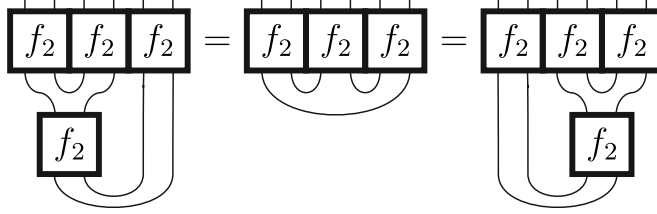

Hence we must have $a_2 = 1$. The remaining conditions to solve can be given as:

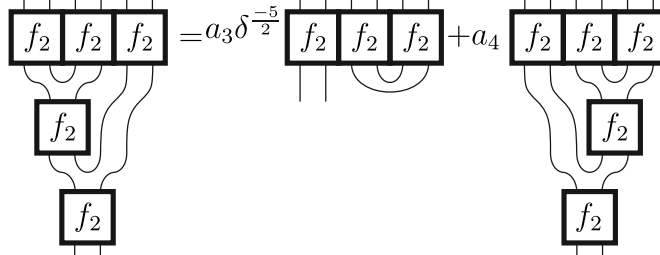
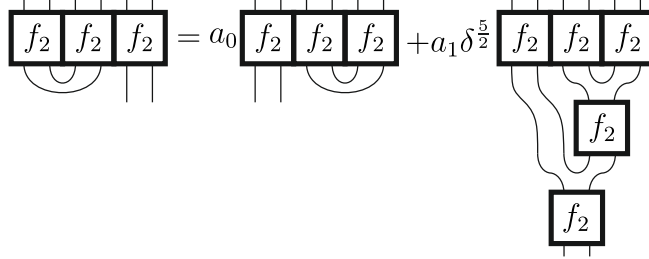

By applying $\mathfrak{m}||$ to these we get:

$$a_0 + a_1 \delta^{\frac{1}{2}} = \delta, \quad a_3 \delta^{-\frac{5}{2}} + a_4 \delta^{-2} = 0$$

By applying $||\mathfrak{m}$ to them we get:

$$a_0 \delta = 1, \quad a_3 \delta^{-\frac{3}{2}} = \delta^{-2}$$

Combining these, we get:

$$a_0 = \delta^{-1}, \quad a_1 = \delta^{-\frac{1}{2}}, \quad a_3 = \delta^{-\frac{1}{2}}, \quad a_4 = -\delta^{-1}$$

Hence the associativity constraint is:

$$\Phi_{(XX)X} = \begin{pmatrix} \delta^{-1} & 0 & \delta^{-\frac{1}{2}} \\ 0 & 1 & 0 \\ \delta^{-\frac{1}{2}} & 0 & -\delta^{-1} \end{pmatrix} \Phi_{X(XX)}$$

Next we want to find the braiding relations. Diagrammatically, these are given by:

$$\begin{array}{c} \begin{array}{|c|} \hline f_2 \\ \hline \end{array} \begin{array}{|c|} \hline f_2 \\ \hline \end{array} = r_0 \begin{array}{|c|} \hline f_2 \\ \hline \end{array} \begin{array}{|c|} \hline f_2 \\ \hline \end{array}, \quad \begin{array}{|c|} \hline f_2 \\ \hline \end{array} \begin{array}{|c|} \hline f_2 \\ \hline \end{array} = r_1 \begin{array}{|c|} \hline f_2 \\ \hline \end{array} \begin{array}{|c|} \hline f_2 \\ \hline \end{array} \\ \begin{array}{|c|} \hline f_2 \\ \hline \end{array} \end{array}$$

For solving the hexagon equation, we have three different cases to consider, which are given by the three components of $\Phi_{(X X) X}$. For the first case, we have:

$$\begin{array}{c} \begin{array}{|c|} \hline f_2 \\ \hline \end{array} \begin{array}{|c|} \hline f_2 \\ \hline \end{array} \begin{array}{|c|} \hline f_2 \\ \hline \end{array} = \delta^{-1} \begin{array}{|c|} \hline f_2 \\ \hline \end{array} \begin{array}{|c|} \hline f_2 \\ \hline \end{array} \begin{array}{|c|} \hline f_2 \\ \hline \end{array} = \delta^{-1} \begin{array}{|c|} \hline f_2 \\ \hline \end{array} \begin{array}{|c|} \hline f_2 \\ \hline \end{array} \begin{array}{|c|} \hline f_2 \\ \hline \end{array} = \frac{(1+\delta r_1^{-1})}{\delta^2} \begin{array}{|c|} \hline f_2 \\ \hline \end{array} \begin{array}{|c|} \hline f_2 \\ \hline \end{array} \begin{array}{|c|} \hline f_2 \\ \hline \end{array} \\ \downarrow c_{X,X} \\ \delta^2 \begin{array}{|c|} \hline f_2 \\ \hline \end{array} \begin{array}{|c|} \hline f_2 \\ \hline \end{array} \begin{array}{|c|} \hline f_2 \\ \hline \end{array} + \delta^2 r_1^{-1} \begin{array}{|c|} \hline f_2 \\ \hline \end{array} \begin{array}{|c|} \hline f_2 \\ \hline \end{array} \begin{array}{|c|} \hline f_2 \\ \hline \end{array} + \delta(1-r_1^{-1}) \begin{array}{|c|} \hline f_2 \\ \hline \end{array} \begin{array}{|c|} \hline f_2 \\ \hline \end{array} \begin{array}{|c|} \hline f_2 \\ \hline \end{array} \\ \parallel \\ r_0^{-1} \begin{array}{|c|} \hline f_2 \\ \hline \end{array} \begin{array}{|c|} \hline f_2 \\ \hline \end{array} \begin{array}{|c|} \hline f_2 \\ \hline \end{array} = \delta^{-1} r_0^{-1} \begin{array}{|c|} \hline f_2 \\ \hline \end{array} \begin{array}{|c|} \hline f_2 \\ \hline \end{array} \begin{array}{|c|} \hline f_2 \\ \hline \end{array} = \delta^{-1} r_0^{-2} \begin{array}{|c|} \hline f_2 \\ \hline \end{array} \begin{array}{|c|} \hline f_2 \\ \hline \end{array} \begin{array}{|c|} \hline f_2 \\ \hline \end{array} \\ \delta^2 r_0^{-1} \begin{array}{|c|} \hline f_2 \\ \hline \end{array} \begin{array}{|c|} \hline f_2 \\ \hline \end{array} \begin{array}{|c|} \hline f_2 \\ \hline \end{array} + \frac{\delta^2}{r_0 r_1} \begin{array}{|c|} \hline f_2 \\ \hline \end{array} \begin{array}{|c|} \hline f_2 \\ \hline \end{array} \begin{array}{|c|} \hline f_2 \\ \hline \end{array} \end{array}$$

Hence we have:

$$\frac{(1+\delta r_1^{-1})}{\delta^2} = \delta^{-1} r_0^{-2}, \quad \delta(1-r_1^{-1}) = \delta^2 r_0^{-1} r_1^{-1}$$

The second hexagon equation gives:

$$\frac{(1 + \delta r_1)}{\delta^2} = \delta^{-1} r_0^2, \quad \delta(1 - r_1) = \delta^2 r_0 r_1$$

For the second case we have:

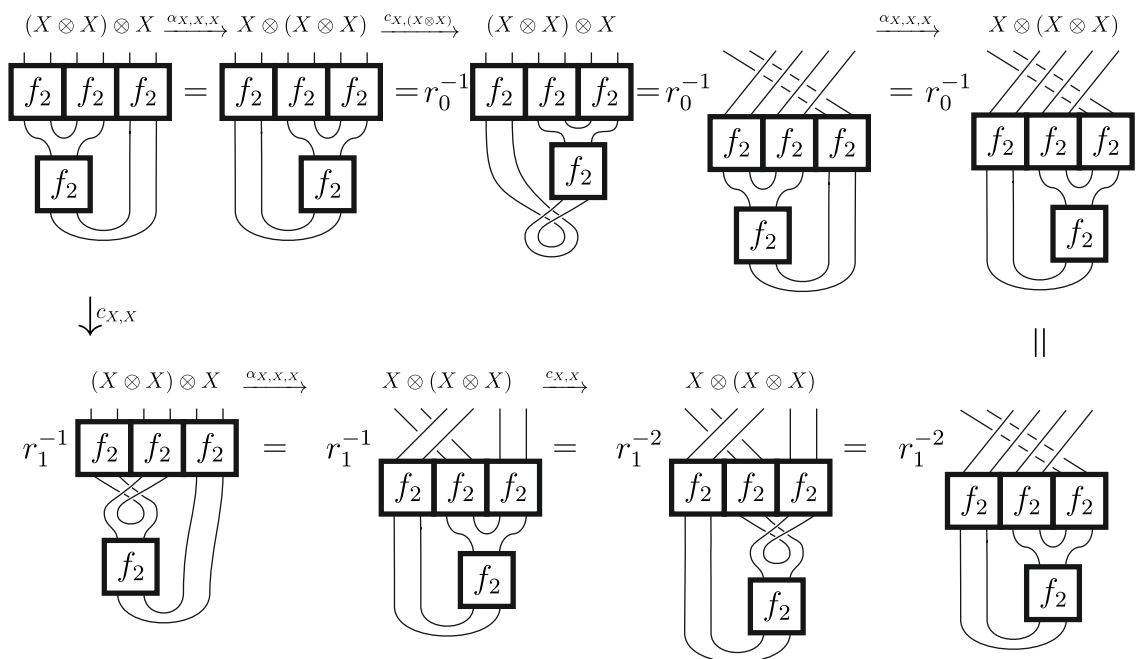

Hence this gives $r_0^{-1} = r_1^{-2}$. The second hexagon equation gives $r_0 = r_1^2$. For the third case, we have:

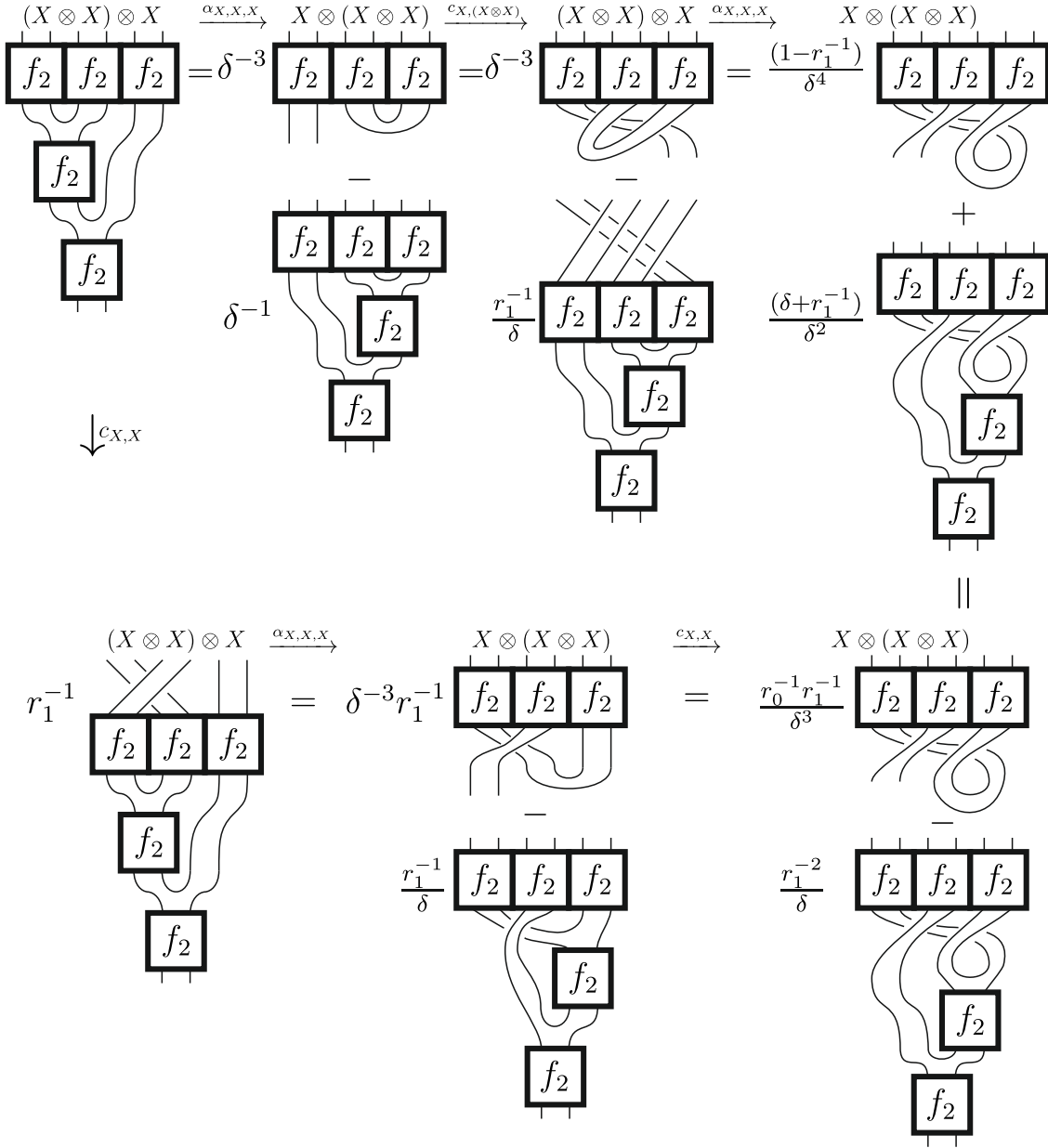

Hence this gives:

$$\frac{(1 - r_1^{-1})}{\delta^4} = \frac{r_0^{-1} r_1^{-1}}{\delta^3}, \quad \frac{(\delta + r_1^{-1})}{\delta^2} = -\frac{r_1^{-2}}{\delta}$$

The second hexagon equation gives:

$$\frac{(1 - r_1)}{\delta^4} = \frac{r_0 r_1}{\delta^3}, \quad \frac{(\delta + r_1)}{\delta^2} = -\frac{r_1^2}{\delta}$$

Combining these results, we find:

$$r_1 + r_1^{-1} = -\delta^{-1}, \quad r_0 = r_1^2$$

We now find to find solutions for the twist on X . Diagrammatically, this is:

$$\boxed{f_2} = t_0 \boxed{f_2}$$

By considering the braid relation on $X \otimes X \rightarrow \mathbf{1}$, and applying $\|\cap$, we have:

$$\boxed{f_2} \boxed{f_2} \boxed{f_2} = r_0^{-1} \boxed{f_2} \boxed{f_2} \boxed{f_2} \rightarrow \boxed{f_2} \boxed{f_2} \boxed{f_2} = r_0^{-1} \boxed{f_2} \boxed{f_2} \boxed{f_2}$$

Hence $t_0 = r_0^{-1}$.

We have then found constraints for the associativity, braiding, and twist relations. These have solutions when $\mathbb{K} = \mathbb{Q}[\zeta_{10}]$, for ζ_{10} a tenth root of unity. There are four choices of solutions, which can be given in terms of r_1 . They are:

$$\begin{aligned} r_1 &= e^{\frac{\pm 3i\pi}{5}}, & r_0 &= e^{\frac{\mp 4i\pi}{5}}, & \delta &= \frac{1 + \sqrt{5}}{2} \\ r_1 &= e^{\frac{\pm i\pi}{5}}, & r_0 &= e^{\frac{\pm i\pi}{5}}, & \delta &= \frac{1 - \sqrt{5}}{2} \end{aligned}$$

From these, we find the S and T matrices are:

$$S = \frac{1}{\sqrt{1 + \delta^2}} \begin{pmatrix} 1 & \delta \\ \delta & -1 \end{pmatrix}, \quad T = \left(\frac{\sqrt{1 + \delta^2}}{1 + r^{-2}\delta^2} \right)^{\frac{1}{3}} \begin{pmatrix} 1 & 0 \\ 0 & r^{-2} \end{pmatrix}$$

Chapter 4

The Quantum Group $\bar{U}_q(\mathfrak{sl}_2)$

We introduce the restricted quantum group $\bar{U}_q(\mathfrak{sl}_2)$, describe its indecomposable modules, their fusion rules and homomorphisms. We also give the decomposition of tensor powers of the two dimensional irreducible module \mathcal{X}_2^+ , and describe the dimensions of its endomorphisms algebras.

4.1 $\bar{U}_q(\mathfrak{sl}_2)$

For $q = e^{i\pi/p}$, $p \geq 2$, and $p \in \mathbb{N}$, the restricted quantum group $\bar{U}_q(\mathfrak{sl}_2)$ over a field \mathbb{K} is the Hopf algebra generated by E, F, K subject to the relations:

$$KEK^{-1} = q^2E \quad KFK^{-1} = q^{-2}F \quad EF - FE = \frac{K - K^{-1}}{q - q^{-1}} \quad (4.1)$$

$$E^p = 0 \quad F^p = 0 \quad K^{2p} = 1 \quad (4.2)$$

and coproduct Δ , counit ϵ , and antipode S :

$$\Delta : E \mapsto E \otimes K + 1 \otimes E \quad F \mapsto F \otimes 1 + K^{-1} \otimes F \quad K \mapsto K \otimes K \quad (4.3)$$

$$\epsilon : E \mapsto 0 \quad F \mapsto 0 \quad K \mapsto 1 \quad (4.4)$$

$$S : E \mapsto -EK^{-1} \quad F \mapsto -KF \quad K \mapsto K^{-1} \quad (4.5)$$

This is a quotient of the quantum group $U_q(\mathfrak{sl}_2)$ by the relations in equation 4.2, and so we can consider (the better understood) $U_q(\mathfrak{sl}_2)$ modules [45] as $\bar{U}_q(\mathfrak{sl}_2)$ modules. This algebra is $2p^3$ dimensional, [60], and so has a finite number of finite dimensional irreducible and projective indecomposable modules. We define the quantum integer $[n] := \frac{q^n - q^{-n}}{q - q^{-1}}$ with $[2] = q + q^{-1}$. For details on quantum integers, see appendix A.

The finite dimensional indecomposable modules for $\bar{U}_q(\mathfrak{sl}_2)$ that are relevant to our construction were given in [42, 60, 65], and consist of the following: $2p - 2$ simple modules, \mathcal{X}_s^\pm , $1 \leq s < p$, two simple projective modules \mathcal{X}_p^\pm and $2p - 2$ indecomposable projective-injective modules \mathcal{P}_s^\pm .

The category of $\bar{U}_q(\mathfrak{sl}_2)$ modules can be given as a direct sum of full subcategories $\bigoplus_{s=0}^p \mathcal{C}(s)$ where $\mathcal{C}(0)$ and $\mathcal{C}(p)$ are semisimple, with $\mathcal{X}_p^+ \in \text{Ob}(\mathcal{C}(p))$, $\mathcal{X}_p^- \in \text{Ob}(\mathcal{C}(0))$. The categories $\mathcal{C}(s)$, $s \neq 0, p$, contain two simple objects each, $\mathcal{X}_s^+, \mathcal{X}_{p-s}^- \in \text{Ob}(\mathcal{C}(s))$ and two indecomposable projective objects $\mathcal{P}_s^+, \mathcal{P}_{p-s}^- \in \text{Ob}(\mathcal{C}(s))$ [1]. An object P is projective if for every surjective homomorphism $f : M \rightarrow N$, and homomorphism $g : P \rightarrow N$, there is a homomorphism $h : P \rightarrow M$ such that $fh = g$.

As well as these, there are also three series of indecomposable modules in each $\mathcal{C}(s)$, $s \neq 0, p$:

$$\begin{array}{lll} \mathcal{M}_s^+(n) & \mathcal{M}_{p-s}^-(n) & 2 \leq n \in \mathbb{N} \\ \mathcal{W}_s^+(n) & \mathcal{W}_{p-s}^-(n) & 2 \leq n \in \mathbb{N} \\ \mathcal{E}_s^+(n; \lambda) & \mathcal{E}_{p-s}^-(n; \lambda) & 1 \leq n \in \mathbb{N} \quad \lambda \in \mathbb{P}^1(\mathbb{K}) \end{array}$$

However, our planar algebra construction is based on $(\mathcal{X}_2^\pm)^{\otimes n}$, and these three series do not appear in its decomposition, so our focus will be on the modules that do, which are $\mathcal{X}_s^\pm, \mathcal{P}_s^\pm$.

For the simple modules \mathcal{X}_s^\pm , $1 \leq s \leq p$, they can be given in terms of a basis as $\{a_n^s\}_{n=0, \dots, s-1}$ with the action of $\bar{U}_q(\mathfrak{sl}_2)$ given by:

$$\begin{aligned} Ka_n &= \pm q^{s-1-2n} a_n \\ Ea_n &= \pm [n][s-n] a_{n-1} \\ Fa_n &= a_{n+1} \end{aligned}$$

where $a_{-1} = a_s = 0$ and $[n] = \frac{q^n - q^{-n}}{q - q^{-1}}$. For \mathcal{X}_s^+ , this basis and action is equivalent to the basis and action for the irreducible $U_q(\mathfrak{sl}_2)$ module V_{s-1} given in [24] by the map $a_k \mapsto [k]! \nu_{s-1-2k}$. Hence we have $\mathcal{X}_s^+ \simeq V_{s-1}$. For \mathcal{X}_s^- , this is the action of $\bar{U}_q(\mathfrak{sl}_2)$ under the automorphism given by $K \mapsto -K, E \mapsto -E, F \mapsto F$ [11].

The projective modules \mathcal{P}_s^\pm , $1 \leq s < p$, for a given choice of p , can be given in terms

of the basis $\{a_i^{s,p}, b_i^{s,p}\}_{0 \leq i \leq s-1} \cup \{x_j^{s,p}, y_j^{s,p}\}_{0 \leq j \leq p-s-1}$. The action of $\bar{U}_q(\mathfrak{sl}_2)$ is given by:

$$\begin{aligned}
Ka_i &= \pm q^{s-1-2i} a_i & Kb_i &= \pm q^{s-1-2i} b_i \\
Kx_j &= \mp q^{p-s-1-2j} x_j & Ky_j &= \mp q^{p-s-1-2j} y_j \\
Ea_i &= \pm [i][s-i] a_{i-1} & Eb_i &= \pm [i][s-i] b_{i-1} + a_{i-1} & Eb_0 &= x_{p-s-1} \\
Ex_j &= \mp [j][p-s-j] x_{j-1} & Ey_j &= \mp [j][p-s-j] y_{j-1} & Ey_0 &= a_{s-1} \\
Fa_i &= a_{i+1} & Fb_i &= b_{i+1} & Fb_{s-1} &= y_0 \\
Fx_j &= x_{j+1} & Fx_{p-s-1} &= a_0 & Fy_j &= y_{j+1}
\end{aligned}$$

where $x_{-1} = a_{-1} = a_s = y_{p-s} = 0$ [23].

The decomposition of tensor products for the modules is given in [42, 63].

Let $1 \leq s \leq t \leq p$, then define;

$$I_{s,t} = \{r = t - s + 2i - 1 | i = 1, \dots, s, r \leq 2p - s - t\} \quad (4.6)$$

$$J_{s+t} = \{r = 2p - 2i - t + s + 1 | i = 1, \dots, s, r \leq p\} \quad (4.7)$$

and set $I_{t,s} = I_{s,t}$, $J_{t+s} = J_{s+t}$ for $s > t$. The simple and projective modules then satisfy:

$$\mathcal{X}_s^+ \otimes \mathcal{X}_t^+ \simeq \bigoplus_{r \in I_{s,t}} \mathcal{X}_r^+ \bigoplus_{r \in J_{s+t}} \mathcal{P}_r^+ \quad (4.8)$$

$$\mathcal{X}_s^\pm \otimes \mathcal{X}_1^- \simeq \mathcal{X}_1^- \otimes \mathcal{X}_s^\pm \simeq \mathcal{X}_s^\mp \quad (4.9)$$

$$\mathcal{P}_s^\pm \otimes \mathcal{X}_1^- \simeq \mathcal{X}_1^- \otimes \mathcal{P}_s^\pm \simeq \mathcal{P}_s^\mp \quad (4.10)$$

$$\mathcal{P}_s^+ \otimes \mathcal{X}_t^+ \simeq \mathcal{X}_t^+ \otimes \mathcal{P}_s^+ \simeq \bigoplus_{r \in I_{s,t}} \mathcal{P}_r^+ \bigoplus_{r \in J_{s+t}} 2\mathcal{P}_r^+ \bigoplus_{r \in J_{p-s+t}} 2\mathcal{P}_r^- \quad s \neq p \quad (4.11)$$

$$\mathcal{P}_s^\alpha \otimes \mathcal{P}_t^\beta \simeq 2\mathcal{X}_s^+ \otimes \mathcal{P}_t^+ \bigoplus 2\mathcal{X}_{p-s}^- \otimes \mathcal{P}_t^+ \quad (4.12)$$

$$\mathcal{P}_s^\alpha \otimes \mathcal{Z} \simeq \mathcal{Z} \otimes \mathcal{P}_s^\alpha \quad s \neq p \quad (4.13)$$

where \mathcal{Z} is an arbitrary module, and we take $\mathcal{P}_p^\pm = \mathcal{X}_p^\pm$.

4.2 Tensor Decomposition of Modules

As a starting point, we want to use equations 4.6 - 4.13 to give the tensor decompositions of various modules for small values of p , as examples for a general decomposition. Note that because of the relations in 4.2, $p = 1$ is trivial.

For the case $p = 2$, the module decompositions are given by:

$I_{s,t}$	1	2
1	{1}	\emptyset
2	\emptyset	\emptyset

J_{s+t}	1	2
1	\emptyset	{2}
2	{2}	{1}

$$\mathcal{X}_2^+ \otimes \mathcal{X}_2^+ \simeq \mathcal{P}_1^+ \quad \mathcal{X}_2^+ \otimes \mathcal{P}_1^+ \simeq 2\mathcal{P}_2^+ \oplus 2\mathcal{P}_2^- \quad \mathcal{P}_1^+ \otimes \mathcal{P}_1^+ \simeq 2\mathcal{P}_1^+ \oplus 2\mathcal{P}_1^-$$

Let $X := \mathcal{X}_2^+$ and $X^{\otimes n} = (\mathcal{X}_2^+)^{\otimes n}$, then we have:

$$X^{\otimes 2} \simeq \mathcal{P}_1^+ \quad X^{\otimes 3} \simeq 2\mathcal{P}_2^+ \oplus 2\mathcal{P}_2^- \quad X^{\otimes 4} \simeq 2\mathcal{P}_1^+ \oplus 2\mathcal{P}_1^- \quad X^{\otimes 5} \simeq 8\mathcal{P}_2^+ \oplus 8\mathcal{P}_2^-$$

For the case $p = 3$, the module decompositions are given by:

$I_{s,t}$	1	2	3
1	{1}	{2}	\emptyset
2	{2}	{1}	\emptyset
3	\emptyset	\emptyset	\emptyset

J_{s+t}	1	2	3
1	\emptyset	\emptyset	{3}
2	\emptyset	{3}	{2}
3	{3}	{2}	{1, 3}

$$\begin{aligned} \mathcal{X}_2^+ \otimes \mathcal{X}_2^+ &\simeq \mathcal{X}_1^+ \oplus \mathcal{P}_3^+ & \mathcal{X}_2^+ \otimes \mathcal{P}_1^+ &\simeq \mathcal{P}_2^+ \oplus 2\mathcal{P}_3^- & \mathcal{P}_1^+ \otimes \mathcal{P}_1^+ &\simeq 2\mathcal{P}_1^+ \oplus 2\mathcal{P}_2^- \oplus 4\mathcal{P}_3^+ \\ \mathcal{X}_2^+ \otimes \mathcal{X}_3^+ &\simeq \mathcal{P}_2^+ & \mathcal{X}_2^+ \otimes \mathcal{P}_2^+ &\simeq \mathcal{P}_1^+ \oplus 2\mathcal{P}_3^+ & \mathcal{P}_1^+ \otimes \mathcal{P}_2^+ &\simeq 2\mathcal{P}_2^+ \oplus 2\mathcal{P}_1^- \oplus 4\mathcal{P}_3^- \\ \mathcal{X}_3^+ \otimes \mathcal{X}_3^+ &\simeq \mathcal{P}_1^+ \oplus \mathcal{P}_3^+ & \mathcal{X}_3^+ \otimes \mathcal{P}_1^+ &\simeq 2\mathcal{P}_3^+ \oplus 2\mathcal{P}_2^- & \mathcal{P}_2^+ \otimes \mathcal{P}_2^+ &\simeq 2\mathcal{P}_1^+ \oplus 4\mathcal{P}_3^+ \oplus 2\mathcal{P}_2^- \\ & & \mathcal{X}_3^+ \otimes \mathcal{P}_2^+ &\simeq 2\mathcal{P}_2^+ \oplus 2\mathcal{P}_3^- & & \end{aligned}$$

$$\begin{aligned} X^{\otimes 2} &\simeq \mathcal{X}_1^+ \oplus \mathcal{P}_3^+ & X^{\otimes 3} &\simeq X \oplus \mathcal{P}_2^+ \\ X^{\otimes 4} &\simeq \mathcal{X}_1^+ \oplus \mathcal{P}_1^+ \oplus 3\mathcal{P}_3^+ & X^{\otimes 5} &\simeq X \oplus 4\mathcal{P}_2^+ \oplus 2\mathcal{P}_3^- \\ X^{\otimes 6} &\simeq \mathcal{X}_1^+ \oplus 9\mathcal{P}_3^+ \oplus 4\mathcal{P}_1^+ \oplus 2\mathcal{P}_2^- & X^{\otimes 7} &\simeq X \oplus 13\mathcal{P}_2^+ \oplus 12\mathcal{P}_3^- \oplus 2\mathcal{P}_1^- \end{aligned}$$

For the case $p = 4$, the module decompositions are given by:

$I_{s,t}$	1	2	3	4
1	{1}	{2}	{3}	\emptyset
2	{2}	{1, 3}	{2}	\emptyset
3	{3}	{2}	{1}	\emptyset
4	\emptyset	\emptyset	\emptyset	\emptyset

J_{s+t}	1	2	3	4
1	\emptyset	\emptyset	\emptyset	{4}
2	\emptyset	\emptyset	{4}	{3}
3	\emptyset	{4}	{3}	{2, 4}
4	{4}	{3}	{2, 4}	{1, 3}

$$\begin{aligned}
\mathcal{X}_2^+ \otimes \mathcal{X}_2^+ &\simeq \mathcal{X}_1^+ \oplus \mathcal{X}_3^+ & \mathcal{X}_2^+ \otimes \mathcal{X}_3^+ &\simeq \mathcal{X}_2^+ \oplus \mathcal{P}_4^+ \\
\mathcal{X}_3^+ \otimes \mathcal{X}_3^+ &\simeq \mathcal{X}_1^+ \oplus \mathcal{P}_3^+ & \mathcal{X}_2^+ \otimes \mathcal{X}_4^+ &\simeq \mathcal{P}_3^+ \\
\mathcal{X}_3^+ \otimes \mathcal{X}_4^+ &\simeq \mathcal{P}_2^+ \oplus \mathcal{P}_4^+ & \mathcal{X}_4^+ \otimes \mathcal{X}_4^+ &\simeq \mathcal{P}_1^+ \oplus \mathcal{P}_3^+
\end{aligned}$$

$$\begin{aligned}
\mathcal{X}_2^+ \otimes \mathcal{P}_1^+ &\simeq \mathcal{P}_2^+ \oplus 2\mathcal{P}_4^- & \mathcal{P}_1^+ \otimes \mathcal{P}_1^+ &\simeq 2\mathcal{P}_1^+ \oplus 2\mathcal{P}_3^- \oplus 4\mathcal{P}_3^+ \\
\mathcal{X}_2^+ \otimes \mathcal{P}_2^+ &\simeq \mathcal{P}_1^+ \oplus \mathcal{P}_3^+ & \mathcal{P}_1^+ \otimes \mathcal{P}_2^+ &\simeq 2\mathcal{P}_2^+ \oplus 2\mathcal{P}_2^- \oplus 4\mathcal{P}_4^- \oplus 4\mathcal{P}_4^+ \\
\mathcal{X}_3^+ \otimes \mathcal{P}_1^+ &\simeq \mathcal{P}_3^+ \oplus 2\mathcal{P}_3^- & \mathcal{P}_2^+ \otimes \mathcal{P}_2^+ &\simeq 2\mathcal{P}_1^+ \oplus 2\mathcal{P}_3^+ \oplus 2\mathcal{P}_1^- \oplus 2\mathcal{P}_3^- \\
\mathcal{X}_3^+ \otimes \mathcal{P}_2^+ &\simeq \mathcal{P}_2^+ \oplus 2\mathcal{P}_4^+ \oplus 2\mathcal{P}_4^- & \mathcal{P}_1^+ \otimes \mathcal{P}_3^+ &\simeq 2\mathcal{P}_3^+ \oplus 2\mathcal{P}_1^- \oplus 4\mathcal{P}_3^- \\
\mathcal{X}_2^+ \otimes \mathcal{P}_3^+ &\simeq \mathcal{P}_2^+ \oplus 2\mathcal{P}_4^+ & \mathcal{P}_2^+ \otimes \mathcal{P}_3^+ &\simeq 2\mathcal{P}_2^+ \oplus 4\mathcal{P}_4^+ \oplus 2\mathcal{P}_2^- \oplus 4\mathcal{P}_4^- \\
\mathcal{X}_3^+ \otimes \mathcal{P}_3^+ &\simeq \mathcal{P}_1^+ \oplus 2\mathcal{P}_3^+ & \mathcal{P}_3^+ \otimes \mathcal{P}_3^+ &\simeq 2\mathcal{P}_1^+ \oplus 4\mathcal{P}_3^+ \oplus 2\mathcal{P}_3^- \\
\mathcal{X}_4^+ \otimes \mathcal{P}_1^+ &\simeq 2\mathcal{P}_4^+ \oplus 2\mathcal{P}_2^- \oplus 2\mathcal{P}_4^- & & \\
\mathcal{X}_4^+ \otimes \mathcal{P}_2^+ &\simeq 2\mathcal{P}_3^+ \oplus 2\mathcal{P}_3^- & & \\
\mathcal{X}_4^+ \otimes \mathcal{P}_3^+ &\simeq 2\mathcal{P}_2^+ \oplus 2\mathcal{P}_4^+ \oplus 2\mathcal{P}_4^- & &
\end{aligned}$$

$$\begin{aligned}
X^{\otimes 2} &\simeq \mathcal{X}_1^+ \oplus \mathcal{X}_3^+ & X^{\otimes 3} &\simeq 2X \oplus \mathcal{P}_4^+ \\
X^{\otimes 4} &\simeq 2\mathcal{X}_1^+ \oplus 2\mathcal{X}_3^+ \oplus \mathcal{P}_3^+ & X^{\otimes 5} &\simeq 4X \oplus 4\mathcal{P}_4^+ \oplus \mathcal{P}_2^+ \\
X^{\otimes 6} &\simeq 4\mathcal{X}_1^+ \oplus 4\mathcal{X}_3^+ \oplus 5\mathcal{P}_3^+ \oplus \mathcal{P}_1^+ & X^{\otimes 7} &\simeq 8X \oplus 14\mathcal{P}_4^+ \oplus 6\mathcal{P}_2^+ \oplus 2\mathcal{P}_4^- \\
X^{\otimes 8} &\simeq 8\mathcal{X}_1^+ \oplus 8\mathcal{X}_3^+ \oplus 20\mathcal{P}_3^+ \oplus 6\mathcal{P}_1^+ \oplus 2\mathcal{P}_3^- & X^{\otimes 9} &\simeq 16X \oplus 48\mathcal{P}_4^+ \oplus 26\mathcal{P}_2^+ \oplus 16\mathcal{P}_4^- \oplus 2\mathcal{P}_2^-
\end{aligned}$$

General Decomposition of $(\mathcal{X}_2^+)^{\otimes n}$.

Taking p as arbitrary, and denoting \mathcal{X}_2^+ by X , we can work out some general decomposition rules for tensor powers of X .

Using the formulae 4.6 - 4.13 given previously, we first note that if $s+t \leq p$ then $J_{s+t} = \emptyset$, and $I_{n,2} = \{n-1, n+1\}$ if $2n+3 \leq 2p$. Hence if $n \leq p-2$ we have:

$$\mathcal{X}_n^+ \otimes X \simeq \mathcal{X}_{n-1}^+ \oplus \mathcal{X}_{n+1}^+$$

For $n = p-1$ we get $I_{p-1,2} = p-2$ and $J_{p+1} = p$, giving $\mathcal{X}_{p-1}^+ \otimes X \simeq \mathcal{X}_{p-2}^+ \oplus \mathcal{P}_p^+$. Note, that $\mathcal{P}_p^+ \simeq \mathcal{X}_p^+$. This is so far the same as the decomposition for $U_q(\mathfrak{sl}_2)$ modules.

For $n = p$, we have $I_{p,2} = \emptyset$, and $J_{p+2} = p-1$, giving $\mathcal{X}_p^+ \otimes X \simeq \mathcal{P}_{p-1}^+$.

As $J_{s+t} = \emptyset$ if $s+t \leq p$, then $J_{p-s+t} = \emptyset$ if $-s+t \geq 0$ and hence $J_{p-n+2} = \emptyset$ if $n \geq 2$.

This gives $\mathcal{P}_{p-1}^+ \otimes X \simeq \mathcal{P}_{p-2}^+ \oplus 2\mathcal{P}_p^+$.

For $2 \leq n \leq p-2$ we have $\mathcal{P}_{n-1}^+ \oplus \mathcal{P}_{n+1}^+$.

Finally for $n = 1$, (and $p \geq 3$), we find $I_{1,2} = 2$, $J_{1+2} = \emptyset$, $J_{p-1} = p$, giving:

$$\mathcal{P}_1^+ \otimes X \simeq \mathcal{P}_2^+ \oplus 2\mathcal{P}_p^-$$

As $\mathcal{P}_s^+ \otimes \mathcal{X}^- \simeq \mathcal{P}_s^-$, the decomposition follows in the same way for the negative modules.

Hence we have the general decomposition:

$$\begin{aligned} X^{\otimes 2} &\simeq \mathcal{X}_1^+ \oplus \mathcal{X}_3^+ \\ X^{\otimes 3} &\simeq 2\mathcal{X}_2^+ \oplus \mathcal{X}_4^+ \\ X^{\otimes 4} &\simeq 2\mathcal{X}_1^+ \oplus 3\mathcal{X}_3^+ \oplus \mathcal{X}_5^+ \\ X^{\otimes 5} &\simeq 5\mathcal{X}_2^+ \oplus 4\mathcal{X}_4^+ \oplus \mathcal{X}_6^+ \\ X^{\otimes 6} &\simeq 5\mathcal{X}_1^+ \oplus 9\mathcal{X}_3^+ \oplus 5\mathcal{X}_5^+ \oplus \mathcal{X}_7^+ \\ X^{\otimes 7} &\simeq 14\mathcal{X}_2^+ \oplus 14\mathcal{X}_4^+ \oplus 6\mathcal{X}_6^+ \oplus \mathcal{X}_8^+ \\ &\vdots \\ X^{\otimes p} &\simeq \dots \oplus \mathcal{P}_{p-1}^+ \\ X^{\otimes(p+1)} &\simeq \dots \oplus 2\mathcal{P}_p^+ \oplus \mathcal{P}_{p-2}^+ \\ X^{\otimes(p+2)} &\simeq \dots \oplus 3\mathcal{P}_{p-1}^+ \oplus \mathcal{P}_{p-3}^+ \\ &\vdots \\ X^{\otimes(2p-2)} &\simeq \dots \oplus \mathcal{P}_1^+ \\ X^{\otimes(2p-1)} &\simeq \dots \oplus 2\mathcal{P}_p^- \\ X^{\otimes(2p)} &\simeq \dots \oplus 2\mathcal{P}_{p-1}^- \\ &\vdots \\ X^{\otimes(3p-2)} &\simeq \dots \oplus 2\mathcal{P}_1^- \end{aligned}$$

We can see that the first indecomposable module to appear in the decomposition is \mathcal{P}_{p-1}^+ which appears in the decomposition of $X^{\otimes p}$. Further, we have that all positive projective modules appear by the $(2p-2)$ th tensor power, and all negative projective modules will appear by the $(3p-2)$ th tensor power. However, we have that no modules \mathcal{X}_k^- will appear in the decomposition of $X^{\otimes n}$ for any n , and hence we must tensor by \mathcal{X}_1^- to get these modules.

This suggests that $End(X^{\otimes n}) \simeq TL_n$ for $n < p$, so the first possibility of finding

$End(X^{\otimes n}) \not\cong TL_n$ is when $n = p$, however we shall see that this doesn't occur until $n = 2p - 1$.

Note that $End(\mathcal{X}_1^-) \simeq \mathbb{C}$, $Hom(\mathcal{X}_1^+, \mathcal{X}_1^-) = 0$. As $\mathcal{X}_1^- \otimes \mathcal{X}_1^- \simeq \mathcal{X}_1^+$ and $\mathcal{X}_k^\pm \otimes \mathcal{X}_1^- \simeq \mathcal{X}_1^- \otimes \mathcal{X}_k^\pm$, we can conclude that $\mathcal{X}_{k_1}^{\alpha_1} \otimes \mathcal{X}_{k_2}^{\alpha_2} \dots \otimes \mathcal{X}_{k_n}^{\alpha_n} \simeq \mathcal{X}_{k_1}^{\beta_1} \otimes \mathcal{X}_{k_2}^{\beta_2} \dots \otimes \mathcal{X}_{k_n}^{\beta_n}$ if and only if $\alpha_1 \alpha_2 \dots \alpha_n = \beta_1 \beta_2 \dots \beta_n$.

Hence if we are looking at tensor powers of \mathcal{X}_2^\pm , we need only consider the two cases where the product of the signs is either positive or negative.

4.3 Multiplicity of Modules and dimension of $End((\mathcal{X}_2^+)^{\otimes n})$

A basic question we want to answer is what is the dimension of $End(X^{\otimes n})$. To answer this we need to know the multiplicities of each module in the decomposition of $X^{\otimes n}$.

For counting the multiplicity of each module appearing in a tensor decomposition, we construct the following diagram: First number the possible vertex positions left to right by $1, \dots, 3p - 1$, which correspond to the modules $\mathcal{X}_1^+, \dots, \mathcal{X}_{p-1}^+, \mathcal{P}_p^+, \dots, \mathcal{P}_1^+, \mathcal{P}_p^-, \dots, \mathcal{P}_1^-$. If module B appears in the decomposition of $X^{\otimes k}$, and a module A appears in the decomposition of $B \otimes \mathcal{X}_2^+$, we put an edge between vertex B of row k and vertex A of row $k + 1$. Summing over the number of paths downwards to a vertex gives the multiplicity for the corresponding module. Then the k th row gives the decomposition of $X^{\otimes k}$.

Edges only connect odd vertices to even ones, and vice versa. The only vertex in row 1 connected to an edge is vertex 2. Generally we have edges connecting vertex n of row k to edges $n - 1$ and $n + 1$ of row $k + 1$, with the following exceptions:

For any k , vertex p of row k only connects to vertex $p + 1$ of row $k + 1$, and likewise for vertex $2p$. Vertex $p + 1$ of row k is connected by a double edge to vertex p of row $k + 1$ (as well as a single edge to vertex $p + 2$), and likewise for vertex $2p + 1$. Vertex $2p - 1$ of row k is connected by a double edge to vertex $2p$ of row $k + 1$ (as well as to vertex $2p - 2$ by a single edge). Vertex $3p - 1$ of row k is connected to vertex p of row $k + 1$ by a double edge (as well as to vertex $3p - 2$ by a single edge).

As an example, the graphs for $p = 2, 3, 4$ are given in figures 4.1, 4.2, 4.3:

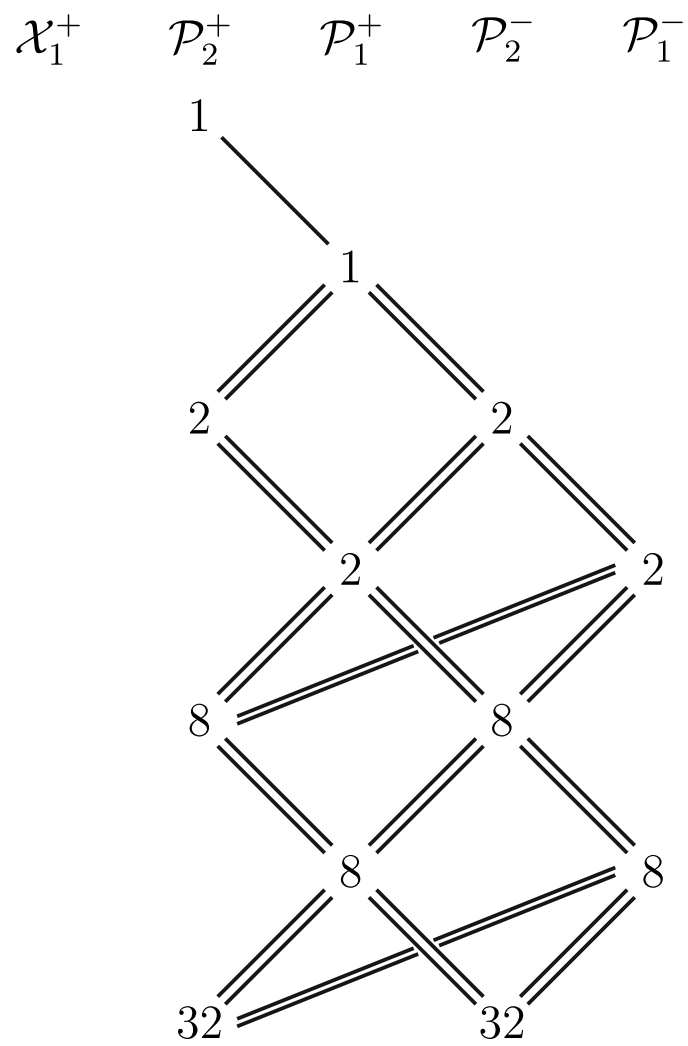

Figure 4.1: Module Decomposition Diagram of $(\mathcal{X}_2^+)^{\otimes n}$ for $p = 2$.

\mathcal{X}_1^+ \mathcal{X}_2^+ \mathcal{P}_3^+ \mathcal{P}_2^+ \mathcal{P}_1^+ \mathcal{P}_3^- \mathcal{P}_2^- \mathcal{P}_1^-

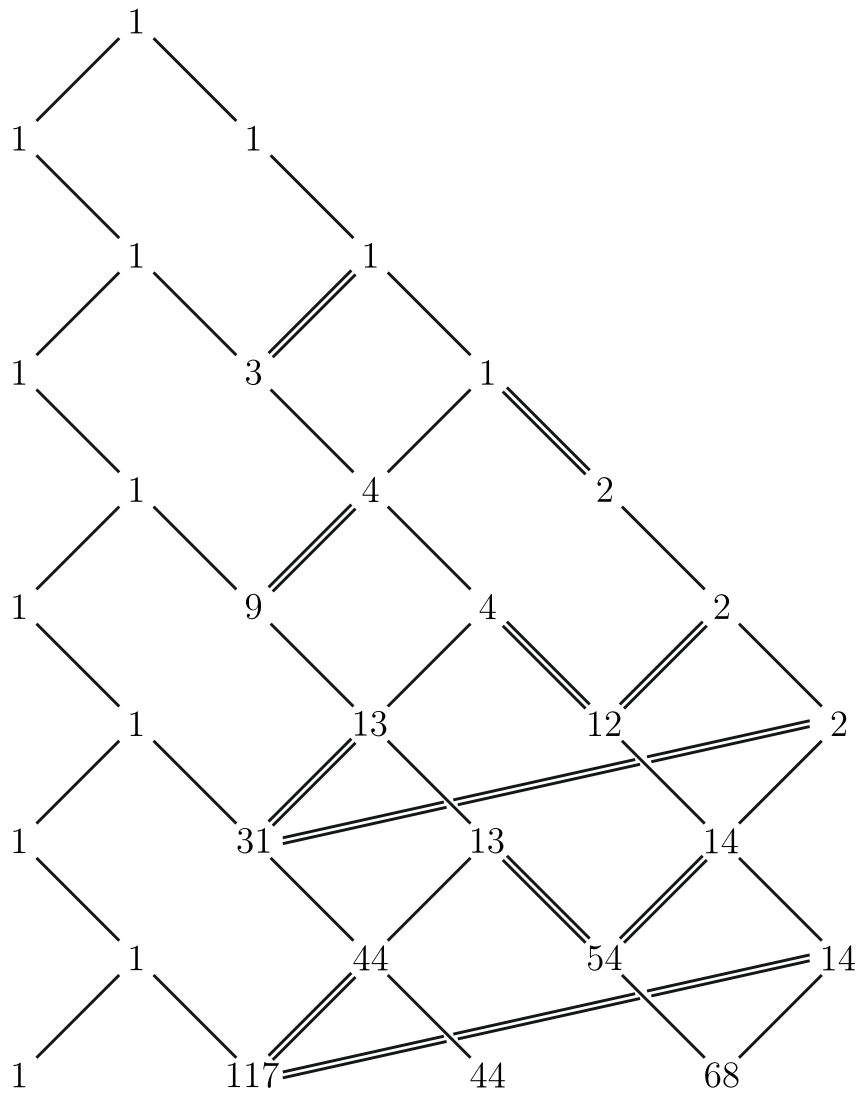

Figure 4.2: Module Decomposition Diagram of $(\mathcal{X}_2^+)^{\otimes n}$ for $p = 3$.

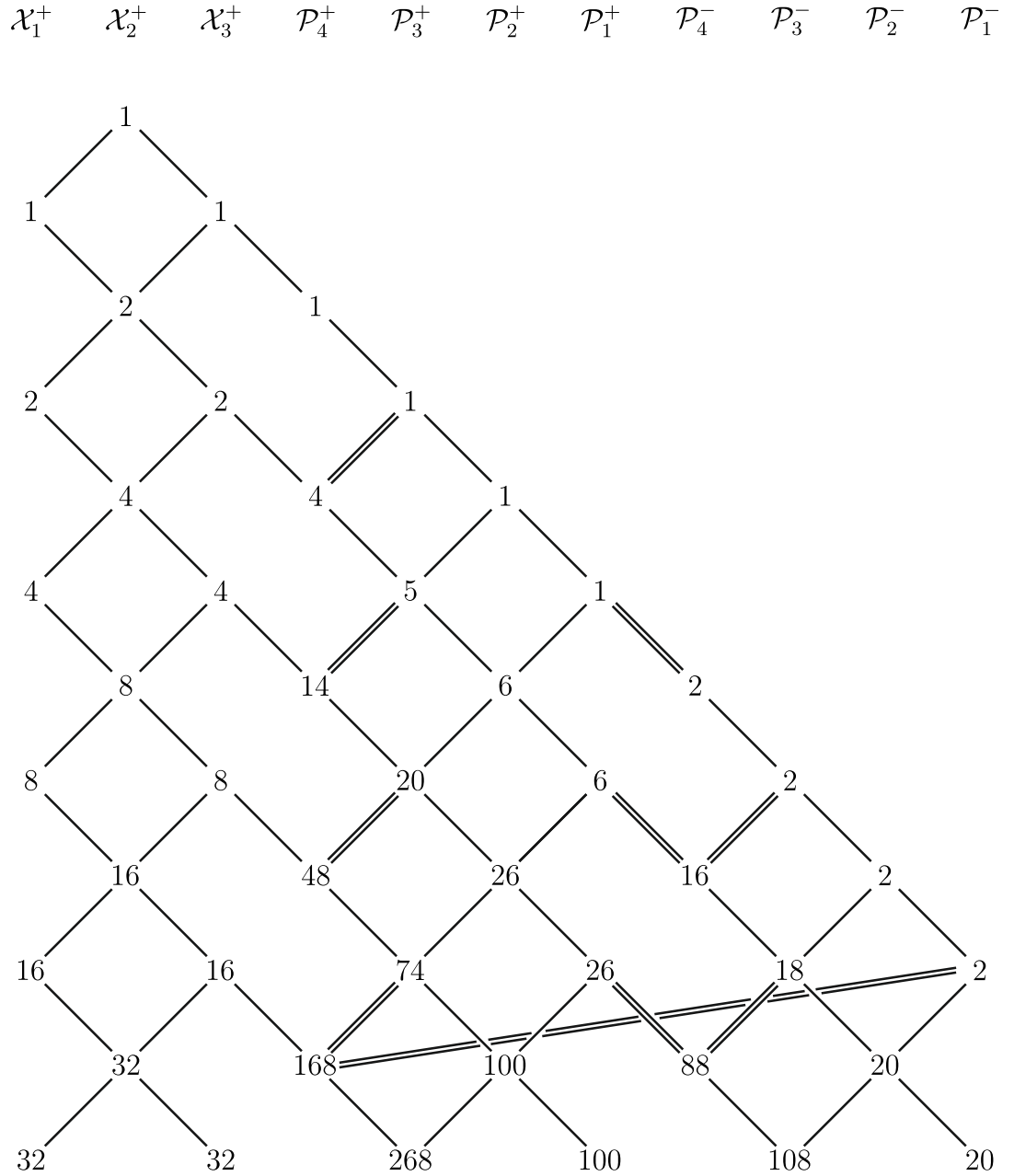

Figure 4.3: Module Decomposition Diagram of $(\mathcal{X}_2^+)^{\otimes n}$ for $p = 4$.

We can check that the module multiplicities given by these decomposition diagrams are consistent by comparing dimensions of the modules. For example, when $p = 4$ the diagram gives $(\mathcal{X}_2^+)^{\otimes 7} \simeq 8\mathcal{X}_2^+ \oplus 14\mathcal{P}_4^+ \oplus 6\mathcal{P}_2^+ \oplus 2\mathcal{P}_4^-$. \mathcal{X}_2^+ has dimension 2, so $(\mathcal{X}_2^+)^{\otimes 7}$ has dimension $2^7 = 128$. For the other side, \mathcal{P}_4^+ and \mathcal{P}_4^- have dimension 4, and \mathcal{P}_2^+ has dimension 8. Hence we have $8(2) + 14(4) + 6(8) + 2(4) = 128$, and so the dimensions of the two sides match.

We can use these diagrams to find the dimension of $End_{\bar{U}_q(\mathfrak{sl}_2)}((\mathcal{X}_2^+)^{\otimes n})$, by counting

the number of possible maps between the various modules. For this, we need the following from [60]. We give our own proof in section 4.4:

Theorem 4.1. *The dimensions of the Hom-spaces of indecomposable modules are given by:*

1. $|Hom(\mathcal{X}_s^\pm, \mathcal{X}_t^\pm)| = 0$ for $s \neq t$ or 1 for $s = t$, for $1 \leq s, t \leq p$.
2. $|Hom(\mathcal{X}_s^\pm, \mathcal{X}_t^\mp)| = 0$ for any $1 \leq s, t \leq p$.
3. $|Hom(\mathcal{P}_s^\pm, \mathcal{X}_t^\pm)| = 0$ for $s \neq t$ or 1 for $s = t$, for $1 \leq s, t \leq p-1$.
4. $|Hom(\mathcal{P}_s^\pm, \mathcal{X}_t^\mp)| = 0$ for any $1 \leq s, t \leq p-1$.
5. $|Hom(\mathcal{P}_s^\pm, \mathcal{P}_t^\pm)| = 0$ for $s \neq t$ or 2 for $s = t$, $1 \leq s, t \leq p-1$.
6. $|Hom(\mathcal{P}_s^\pm, \mathcal{P}_t^\mp)| = 0$ for $s \neq p-t$ or 2 for $s = p-t$, for $1 \leq s, t \leq p-1$.

Given modules A, B , for direct sums of multiples of them $n_A A$, and $n_B B$, ($n_A, n_B \in \mathbb{N}$), the homomorphisms between them are given as an $n_A \times n_B$ matrix with entries in $Hom(A, B)$, i.e.

$$Hom(n_A A, n_B B) \simeq \begin{pmatrix} \alpha_{11} & \dots & \alpha_{1n_B} \\ \vdots & \ddots & \vdots \\ \alpha_{n_A 1} & \dots & \alpha_{n_A n_B} \end{pmatrix}$$

where $\alpha_{ij} \in Hom(A, B)$. Hence $|Hom(n_A A, n_B B)| = n_A n_B |Hom(A, B)|$.

Given the decomposition of $(\mathcal{X}_2^+)^{\otimes n}$, denote the multiplicity of a module A by $M(A)$, then we have the following:

$$\begin{aligned} \left| End_{\bar{U}_q(\mathfrak{sl}_2)}((\mathcal{X}_2^+)^{\otimes n}) \right| &= (M(\mathcal{P}_p^-))^2 + \sum_{i=1}^p (M(\mathcal{X}_i^+))^2 \\ &+ \sum_{j=1}^{p-1} \left(2(M(\mathcal{P}_j^+))^2 + 2(M(\mathcal{P}_j^-))^2 + 2M(\mathcal{X}_j^+)M(\mathcal{P}_j^+) + 4M(\mathcal{P}_j^+)M(\mathcal{P}_{p-j}^-) \right) \end{aligned}$$

Using this we can give the dimensions of $End_{\bar{U}_q(\mathfrak{sl}_2)}((\mathcal{X}_2^+)^{\otimes n})$ for small n and p :

$p \setminus n$	1	2	3	4	5	6	7	8	9	10	11	12
2	1	2	8	32	128	512	2048	8192	32768	131072	524288	2097152
3	1	2	5	14	45	162	621	2446	9733	38866	155381	621422
4	1	2	5	14	42	132	432	1472	5216	19136	72192	278016
5	1	2	5	14	42	132	429	1430	4865	16850	59350	212500

The dimension of the n th Temperley-Lieb algebra is given by the n th Catalan number

$$C_n := \frac{1}{n+1} \binom{2n}{n} = 1, 2, 5, 14, 42, 132, 429, 1430, 4862, 16796, 58786, 208012, \dots \text{ [33].}$$

If we subtract C_n from each entry of the above table, we get:

$p \setminus n$	1	2	3	4	5	6	7	8	9	10	11	12
2	0	0	3	18	86	380	1619	6762	27906	114276	465502	1889140
3	0	0	0	0	3	30	192	1016	4871	22070	96595	413410
4	0	0	0	0	0	0	3	42	354	2340	13406	70004
5	0	0	0	0	0	0	0	0	3	54	564	4488

Denote $|End_{\bar{U}_q(\mathfrak{sl}_2)}((\mathcal{X}_2^+)^{\otimes n})|$ by $D_{n,p}$. From the second table we see that $D_{n,p} = C_n$, $n < 2p - 1$, $D_{2p-1,p} = C_{2p-1} + 3$, $D_{2p,p} = C_{2p} + 12p - 6$.

We relabel the multiplicities of modules in the decomposition of $(\mathcal{X}_2^+)^{\otimes n}$ by $M_{i,n}$ where $i = 1, \dots, p$ corresponds to $\mathcal{X}_1^+, \dots, \mathcal{X}_p^+$, $i = p+1, \dots, 2p-1$ corresponds to $\mathcal{P}_{p-1}^+, \dots, \mathcal{P}_1^+$, and $i = 2p, \dots, 3p-1$ corresponds to $\mathcal{P}_p^-, \dots, \mathcal{P}_1^-$.

Clearly for $n = 1$, $M_{2,1} = 1$, and all other $M_{i,1} = 0$. When n is odd, $M_{2i+1,n} = 0$, and when n is even, $M_{2i,n} = 0$. $M_{i,n} = 0$ for all $i > n + 1$.

From the general decomposition rules given in 4.2, we have the following:

$$\begin{aligned}
M_{i,n} &= M_{i-1,n-1} + M_{i+1,n-1}, \quad i < p-1, \quad M_{0,n} = 0, \quad M_{3p,n} = 0 \\
M_{n+1,n} &= 1, \quad n < 2p-1, \quad M_{m+1,m} = 2, \quad m \geq 2p-1 \\
M_{p-1,p+2k} &= M_{p-2,p+2k-1}, \quad k \geq 0 \\
M_{p,p+2k+1} &= 2M_{p+1,p+2k} + M_{p-1,p+2k}, \quad k \geq 0 \\
M_{2p-1,2p+2k} &= M_{2p-2,2p+2k-1}, \quad k \geq 0 \\
M_{2p,2p+2k+1} &= 2M_{2p+1,2p+2k} + 2M_{2p-1,2p+2k}, \quad k \geq 0 \\
M_{p,3p+2k-1} &= 2M_{2p-1,3p+2k-2} + 2M_{p+1,3p-2k-2} + M_{p-1,3p+2k-2}, \quad k \geq 0
\end{aligned}$$

In terms of this new labelling, we have:

$$\begin{aligned}
D_n &= M_{2p,n}^2 + \sum_{i=1}^p M_{i,n}^2 + \sum_{j=1}^{p-1} (2M_{p+j,n}^2 + 2M_{2p+j,n}^2 + 2M_{p-j,n}M_{p+j,n} + 4M_{p+j,n}M_{3p-j,n}) \\
&= \sum_{i=1}^p M_{i,n}^2 = C_n, \quad n < p \\
&= \sum_{i=1}^p M_{i,n}^2 + \sum_{j=1}^{p-1} (2M_{p+j,n}^2 + 2M_{p-j,n}M_{p+j,n}), \quad n < 2p-1
\end{aligned}$$

By considering the dimensions of modules we also have:

$$2^n = \sum_{i=1}^p iM_{i,n} + pM_{2p,n} + 2p \sum_{j=1}^{p-1} (M_{p+j,n} + M_{2p+j,n})$$

Given these formulae, we can now proceed to give a proof of the following, which was originally detailed in [25]:

Theorem 4.2.

$$|End((\mathcal{X}_2^+)^{\otimes n})| = C_n, \quad n < 2p-1$$

$$|End((\mathcal{X}_2^+)^{\otimes 2p-1})| = C_{2p-1} + 3$$

Proof. The case $n < p$ is already known from the Temperley-Lieb algebra, so we only need focus on the case $n \geq p$.

Let $\begin{Bmatrix} a \\ b \end{Bmatrix} := \binom{a}{b} - \binom{a}{b-1}$, then for $n < p$ we have:

$$M_{2i+1,n} = \begin{Bmatrix} n \\ \lfloor \frac{n}{2} \rfloor - i \end{Bmatrix}, \quad M_{2i,n} = 0, \quad n \text{ even}$$

$$M_{2i,n} = \begin{Bmatrix} n \\ \lfloor \frac{(n+1)}{2} \rfloor - i \end{Bmatrix}, \quad M_{2i+1,n} = 0, \quad n \text{ odd}$$

Or more generally, the non-zero terms are given by $M_{j,n} = \left\{ \begin{matrix} n \\ \lfloor \frac{(n+1)}{2} \rfloor - \lfloor \frac{j}{2} \rfloor \end{matrix} \right\}$, $j \leq n+1$.

For $n \geq p$, this changes slightly, and we find that for terms of the form $M_{p-1-2j,p+2k}$, $M_{p-2-2j,p+1+2k}$, $j \leq k$, $0 \leq k \leq \frac{p-1}{2}$, they are now given by:

$$M_{p-1-2j,p+2k} = \left\{ \begin{matrix} p+2k \\ k+j+1 \end{matrix} \right\} - \left\{ \begin{matrix} p+2k \\ k-j \end{matrix} \right\}$$

$$M_{p-2-2j,p+1+2k} = \left\{ \begin{matrix} p+2k+1 \\ k+j+2 \end{matrix} \right\} - \left\{ \begin{matrix} p+2k+1 \\ k-j \end{matrix} \right\}$$

We have the combinatorial identity:

$$\sum_{i=0}^{\lfloor \frac{n}{2} \rfloor} \left\{ \begin{matrix} n \\ i \end{matrix} \right\}^2 = C_n$$

and since $D_{n,p} = \sum_{i=0}^p M_{i,n}^2$ for $n < p$, this gives:

$$\sum_{i=1}^p M_{i,n}^2 = \sum_{i=1}^{n+1} M_{i,n}^2 = \sum_{\substack{i \\ M_{i,n} \neq 0}}^{n+1} \left\{ \begin{matrix} n \\ \lfloor \frac{(n+1)}{2} \rfloor - \lfloor \frac{i}{2} \rfloor \end{matrix} \right\}^2 = \sum_{i=0}^{\lfloor \frac{n}{2} \rfloor} \left\{ \begin{matrix} n \\ i \end{matrix} \right\}^2 = C_n$$

For $p \leq n < 2p-1$, we have:

$$D_{n,p} = \sum_{i=1}^p M_{i,n}^2 + 2M_{p+i,n}^2 + 2M_{p-i,n}M_{p+i,n}$$

$$D_{p+2k,p} = \sum_{j=0}^k \sum_{i=0}^{p-2-2k} M_{i,p+2k}^2 + M_{p-1-2j,p+2k}^2 + 2M_{p+1+2j,p+2k}^2$$

$$+ 2M_{p-1-2j,p+2k}M_{p+1+2j,p+2k}$$

$$D_{p+1+2k,p} = \sum_{j=0}^k \sum_{i=0}^{p-3-2k} M_{i,p+1+2k}^2 + M_{p-2-2j,p+1+2k}^2 + M_{p,p+1+2k}^2 + 2M_{p+2+2j,p+1+2k}^2$$

$$+ 2M_{p-2-2j,p+1+2k}M_{p+2+2j,p+1+2k}$$

We want to show that $D_{p+2k,p} = C_{p+2k}$, $D_{p+1+2k,p} = C_{p+1+2k}$. Hence, using the previous

combinatorial identity, we want to show:

$$\begin{aligned}
& \sum_{j=0}^k M_{p-1-2j,p+2k}^2 + 2M_{p+1+2j,p+2k}^2 + 2M_{p-1-2j,p+2k}M_{p+1+2j,p+2k} \\
&= \sum_{l=p-1-2k}^{p+1+2k} \left\{ \begin{matrix} p+2k \\ \lfloor \frac{p+1}{2} \rfloor + k - \lfloor \frac{l}{2} \rfloor \end{matrix} \right\}^2 = \sum_{l=0}^{2k+1} \left\{ \begin{matrix} p+2k \\ l \end{matrix} \right\}^2 \\
& \sum_{j=0}^k M_{p-2-2j,p+1+2k}^2 + M_{p,p+1+2k}^2 + 2M_{p+2+2j,p+1+2k}^2 + 2M_{p-2-2j,p+1+2k}M_{p+2+2j,p+1+2k} \\
&= \sum_{l=p-2-2k}^{p+2+2k} \left\{ \begin{matrix} p+2k+1 \\ \lfloor \frac{p}{2} \rfloor + k + 1 - \lfloor \frac{l}{2} \rfloor \end{matrix} \right\}^2 = \sum_{l=0}^{2k+2} \left\{ \begin{matrix} p+2k+1 \\ l \end{matrix} \right\}^2
\end{aligned}$$

For the first case, we have:

$$\begin{aligned}
& \sum_{j=0}^k M_{p-1-2j,p+2k}^2 + 2M_{p+1+2j,p+2k}^2 + 2M_{p-1-2j,p+2k}M_{p+1+2j,p+2k} \\
&= \sum_{j=0}^k \left(\left\{ \begin{matrix} p+2k \\ k+j+1 \end{matrix} \right\} - \left\{ \begin{matrix} p+2k \\ k-j \end{matrix} \right\} \right)^2 + 2 \left\{ \begin{matrix} p+2k \\ k-j \end{matrix} \right\}^2 \\
& \quad + 2 \left(\left\{ \begin{matrix} p+2k \\ k+j+1 \end{matrix} \right\} - \left\{ \begin{matrix} p+2k \\ k-j \end{matrix} \right\} \right) \left\{ \begin{matrix} p+2k \\ k-j \end{matrix} \right\} \\
&= \sum_{j=0}^k \left\{ \begin{matrix} p+2k \\ k+j+1 \end{matrix} \right\}^2 - 2 \left\{ \begin{matrix} p+2k \\ k+j+1 \end{matrix} \right\} \left\{ \begin{matrix} p+2k \\ k-j \end{matrix} \right\} + \left\{ \begin{matrix} p+2k \\ k-j \end{matrix} \right\}^2 + 2 \left\{ \begin{matrix} p+2k \\ k-j \end{matrix} \right\}^2 \\
& \quad + 2 \left\{ \begin{matrix} p+2k \\ k+j+1 \end{matrix} \right\} \left\{ \begin{matrix} p+2k \\ k-j \end{matrix} \right\} - 2 \left\{ \begin{matrix} p+2k \\ k-j \end{matrix} \right\}^2 \\
&= \sum_{j=0}^k \left\{ \begin{matrix} p+2k \\ k+j+1 \end{matrix} \right\}^2 + \left\{ \begin{matrix} p+2k \\ k-j \end{matrix} \right\}^2 = \sum_{l=0}^{2k+1} \left\{ \begin{matrix} p+2k \\ l \end{matrix} \right\}^2
\end{aligned}$$

For the second case, we have:

$$\begin{aligned}
& \sum_{j=0}^k M_{p-2-2j,p+1+2k}^2 + M_{p,p+1+2k}^2 + 2M_{p+2+2j,p+1+2k}^2 + 2M_{p-2-2j,p+1+2k}M_{p+2+2j,p+1+2k} \\
&= \sum_{j=0}^k \left(\left\{ \begin{matrix} p+2k+1 \\ k+j+2 \end{matrix} \right\} - \left\{ \begin{matrix} p+2k+1 \\ k-j \end{matrix} \right\} \right)^2 + \left\{ \begin{matrix} p+2k+1 \\ k+1 \end{matrix} \right\}^2 + 2 \left\{ \begin{matrix} p+2k+1 \\ k-j \end{matrix} \right\}^2 \\
& \quad + 2 \left(\left\{ \begin{matrix} p+2k+1 \\ k+j+2 \end{matrix} \right\} - \left\{ \begin{matrix} p+2k+1 \\ k-j \end{matrix} \right\} \right) \left\{ \begin{matrix} p+2k+1 \\ k-j \end{matrix} \right\}
\end{aligned}$$

$$\begin{aligned}
&= \sum_{j=0}^k \left\{ \begin{matrix} p+2k+1 \\ k+j+2 \end{matrix} \right\}^2 - 2 \left\{ \begin{matrix} p+2k+1 \\ k+j+2 \end{matrix} \right\} \left\{ \begin{matrix} p+2k+1 \\ k-j \end{matrix} \right\} + \left\{ \begin{matrix} p+2k+1 \\ k-j \end{matrix} \right\}^2 \\
&\quad + \left\{ \begin{matrix} p+2k+1 \\ k+1 \end{matrix} \right\}^2 + 2 \left\{ \begin{matrix} p+2k+1 \\ k-j \end{matrix} \right\}^2 + 2 \left\{ \begin{matrix} p+2k+1 \\ k+j+2 \end{matrix} \right\} \left\{ \begin{matrix} p+2k+1 \\ k-j \end{matrix} \right\} \\
&\quad - 2 \left\{ \begin{matrix} p+2k+1 \\ k-j \end{matrix} \right\}^2 \\
&= \sum_{j=0}^k \left\{ \begin{matrix} p+2k+1 \\ k+j+2 \end{matrix} \right\}^2 + \left\{ \begin{matrix} p+2k+1 \\ k-j \end{matrix} \right\}^2 + \left\{ \begin{matrix} p+2k+1 \\ k+1 \end{matrix} \right\}^2 = \sum_{l=0}^{2k+2} \left\{ \begin{matrix} p+2k+1 \\ l \end{matrix} \right\}^2
\end{aligned}$$

Hence we have shown that $D_{n,p} = C_n$ for $n < 2p - 1$.

For $D_{2p-1,p}$, we have:

$$D_{2p-1,p} = M_{2p,2p-1}^2 + M_{p,2p-1}^2 + \sum_{i=1}^{p-1} M_{i,2p-1}^2 + 2M_{p+i,2p-1}^2 + 2M_{p-i,2p-1}M_{p+i,2p-1}$$

For the $M_{j,k}$, we have:

$$M_{p,2p-1} = \left\{ \begin{matrix} 2p-1 \\ \frac{p}{2} \end{matrix} \right\}, \quad p \text{ even}$$

$$M_{p,2p-1} = 0, \quad p \text{ odd}$$

$$M_{2p,2p-1} = 2 \left\{ \begin{matrix} 2p-1 \\ 0 \end{matrix} \right\}$$

$$M_{2i,2p-1} = \left\{ \begin{matrix} 2p-1 \\ p-i \end{matrix} \right\} - \left\{ \begin{matrix} 2p-1 \\ i \end{matrix} \right\}, \quad 0 < 2i < p-1$$

$$M_{2j,2p-1} = \left\{ \begin{matrix} 2p-1 \\ p-j \end{matrix} \right\}, \quad p < 2j < 2p-1$$

For p odd, we then have:

$$\begin{aligned}
D_{2p-1,p} &= \sum_{i=1}^{\lfloor \frac{p-1}{2} \rfloor} 4 \left\{ \begin{matrix} 2p-1 \\ 0 \end{matrix} \right\}^2 + \left(\left(\left\{ \begin{matrix} 2p-1 \\ p-i \end{matrix} \right\} - \left\{ \begin{matrix} 2p-1 \\ i \end{matrix} \right\} \right) \right)^2 + 2 \left\{ \begin{matrix} 2p-1 \\ i \end{matrix} \right\}^2 \\
&\quad + 2 \left(\left(\left\{ \begin{matrix} 2p-1 \\ p-i \end{matrix} \right\} - \left\{ \begin{matrix} 2p-1 \\ i \end{matrix} \right\} \right) \right) \left\{ \begin{matrix} 2p-1 \\ i \end{matrix} \right\}
\end{aligned}$$

$$\begin{aligned}
&= \sum_{i=1}^{\lfloor \frac{p-1}{2} \rfloor} 4 \begin{Bmatrix} 2p-1 \\ 0 \end{Bmatrix}^2 + \begin{Bmatrix} 2p-1 \\ p-i \end{Bmatrix}^2 - 2 \begin{Bmatrix} 2p-1 \\ p-i \end{Bmatrix} \begin{Bmatrix} 2p-1 \\ i \end{Bmatrix} \\
&\quad + \begin{Bmatrix} 2p-1 \\ i \end{Bmatrix}^2 + 2 \begin{Bmatrix} 2p-1 \\ i \end{Bmatrix}^2 + 2 \begin{Bmatrix} 2p-1 \\ p-i \end{Bmatrix} \begin{Bmatrix} 2p-1 \\ i \end{Bmatrix} \\
&\quad - 2 \begin{Bmatrix} 2p-1 \\ i \end{Bmatrix}^2 \\
&= \sum_{i=1}^{\lfloor \frac{p-1}{2} \rfloor} 4 \begin{Bmatrix} 2p-1 \\ 0 \end{Bmatrix}^2 + \begin{Bmatrix} 2p-1 \\ p-i \end{Bmatrix}^2 + \begin{Bmatrix} 2p-1 \\ i \end{Bmatrix}^2 \\
&= \sum_{l=0}^{p-1} \begin{Bmatrix} 2p-1 \\ l \end{Bmatrix}^2 + 3 \begin{Bmatrix} 2p-1 \\ 0 \end{Bmatrix}^2 = C_{2p-1} + 3
\end{aligned}$$

For p even, we have:

$$\begin{aligned}
D_{2p-1,p} &= \sum_{i=1}^{\lfloor \frac{p-1}{2} \rfloor} 4 \begin{Bmatrix} 2p-1 \\ 0 \end{Bmatrix}^2 + \begin{Bmatrix} 2p-1 \\ \frac{p}{2} \end{Bmatrix}^2 + \left(\begin{Bmatrix} 2p-1 \\ p-i \end{Bmatrix} - \begin{Bmatrix} 2p-1 \\ i \end{Bmatrix} \right)^2 \\
&\quad + 2 \begin{Bmatrix} 2p-1 \\ i \end{Bmatrix}^2 + 2 \left(\begin{Bmatrix} 2p-1 \\ p-i \end{Bmatrix} - \begin{Bmatrix} 2p-1 \\ i \end{Bmatrix} \right) \begin{Bmatrix} 2p-1 \\ i \end{Bmatrix} \\
&= \sum_{i=1}^{\lfloor \frac{p-1}{2} \rfloor} 4 \begin{Bmatrix} 2p-1 \\ 0 \end{Bmatrix}^2 + \begin{Bmatrix} 2p-1 \\ \frac{p}{2} \end{Bmatrix}^2 + \begin{Bmatrix} 2p-1 \\ p-i \end{Bmatrix}^2 \\
&\quad - 2 \begin{Bmatrix} 2p-1 \\ p-i \end{Bmatrix} \begin{Bmatrix} 2p-1 \\ i \end{Bmatrix} + \begin{Bmatrix} 2p-1 \\ i \end{Bmatrix}^2 + 2 \begin{Bmatrix} 2p-1 \\ i \end{Bmatrix}^2 \\
&\quad + 2 \begin{Bmatrix} 2p-1 \\ p-i \end{Bmatrix} \begin{Bmatrix} 2p-1 \\ i \end{Bmatrix} - 2 \begin{Bmatrix} 2p-1 \\ i \end{Bmatrix}^2 \\
&= \sum_{i=1}^{\lfloor \frac{p-1}{2} \rfloor} 4 \begin{Bmatrix} 2p-1 \\ 0 \end{Bmatrix}^2 + \begin{Bmatrix} 2p-1 \\ \frac{p}{2} \end{Bmatrix}^2 + \begin{Bmatrix} 2p-1 \\ p-i \end{Bmatrix}^2 + \begin{Bmatrix} 2p-1 \\ i \end{Bmatrix}^2 \\
&= \sum_{i=0}^{p-1} \begin{Bmatrix} 2p-1 \\ i \end{Bmatrix}^2 + 3 \begin{Bmatrix} 2p-1 \\ 0 \end{Bmatrix}^2 = C_{2p-1} + 3
\end{aligned}$$

Hence we have shown that $D_{2p-1,p} = C_{2p-1} + 3$. \square

$$\text{Let } G_{n,i} := \sum_{j=0}^{\lfloor \frac{i}{2} \rfloor} 2 \begin{Bmatrix} n \\ i+1-j \end{Bmatrix} \begin{Bmatrix} n \\ j \end{Bmatrix} + \left(\lfloor \frac{i+1}{2} \rfloor - \lfloor \frac{i}{2} \rfloor \right) \begin{Bmatrix} n \\ \lfloor \frac{i}{2} \rfloor + 1 \end{Bmatrix}^2.$$

We claim that in general, the dimension of $End_{\bar{U}_q(\mathfrak{sl}_2)}((\mathcal{X}_2^+)^{\otimes n})$ can be given by the

following formula:

Conjecture 4.1.

$$D_n = C_n + \sum_{j=0}^{\lfloor \frac{n}{p} \rfloor} (n+1)(n+3)G_{n,n-(j+2)p}$$

for all n .

4.4 $\bar{U}_q(\mathfrak{sl}_2)$ Invariant Maps between Modules.

As both a proof of theorem 4.1, and for later use, we want to classify the sets of linear maps on the projective modules that commute with the action of $\bar{U}_q(\mathfrak{sl}_2)$ and describe them in terms of module bases. We can split these maps into three types; endomorphisms on the projective modules, homomorphisms between different projective modules, and homomorphisms between the projective and simple modules.

Consider first endomorphisms on the projective modules.

4.4.1 Projective module Endomorphisms

Proposition 4.1. *Given \mathcal{P}_s^\pm , $1 \leq s < p$, $\text{End}_{\bar{U}_q(\mathfrak{sl}_2)}(\mathcal{P}_s^\pm)$ is two-dimensional and $\theta : \mathcal{P}_s^\pm \rightarrow \mathcal{P}_s^\pm$, has the general form:*

$$\theta(a_i) = fa_i \qquad \theta(b_i) = ga_i + fb_i \qquad (4.14)$$

$$\theta(x_j) = fx_j \qquad \theta(y_j) = fy_j \qquad (4.15)$$

where $0 \leq i \leq s-1$, $0 \leq j \leq p-s-1$ and $f, g \in \mathbb{K}$.

Proof. As the action on the positive and negative modules only differs by a sign change, we restrict the proof to the positive case.

Note that because of the K -action, any endomorphism can only map elements to those with the same K -weight. For the K -action on \mathcal{P}_s^+ we have:

$$\begin{aligned} K(x_j) &= -q^{p-s-1-2j}x_j & K(y_j) &= -q^{p-s-1-2j}a_i \\ K(a_i) &= q^{s-1-2i}a_i & K(b_i) &= q^{s-1-2i}b_i \end{aligned}$$

For there to be a map between the subspaces with bases $\{a_i, b_i\}$ and $\{x_j, y_j\}$ would require that $2p-s-1-2j = s-1-2i \pmod{2p}$, which requires $2i-2j = 2s \pmod{2p}$. As

$0 \leq i \leq s-1$, $0 \leq j \leq p-s-1$, we have that $2s+2-2p \leq 2i-2j \leq 2s-2$. Hence there is no possible solution, and so there are no maps between $\{a_i, b_i\}$ and $\{x_j, y_j\}$. This means that any endomorphism on \mathcal{P}_s^+ is of the form:

$$\begin{aligned}\theta(a_i) &= f_i^a a_i + g_i^b b_i & \theta(b_i) &= f_i^b b_i + g_i^a a_i \\ \theta(x_j) &= f_j^x x_j + g_j^y y_j & \theta(y_j) &= f_j^y y_j + g_j^x x_j\end{aligned}$$

where $f, g \in \mathbb{K}$.

The F -action is non-zero on every element, except for y_{p-s-1} and a_{s-1} . Hence we have:

$$F(\theta(y_{p-s-1})) = F(f_{p-s-1}^y y_{p-s-1} + g_{p-s-1}^x x_{p-s-1}) = g_{p-s-1}^x a_0 = \theta(F(y_{p-s-1})) = 0$$

this gives $g_{p-s-1}^x = 0$, and so $\theta(y_{p-s-1}) = f_{p-s-1}^y y_{p-s-1}$.

Given $E(y_j) = -[j][p-s-j]y_{j-1}$, $E(x_j) = -[j][p-s-j]x_{j-1}$ we have:

$$\begin{aligned}E(\theta(y_j)) &= E(f_j^y y_j + g_j^x x_j) = -[j][p-s-j](f_j^y y_{j-1} + g_j^x x_{j-1}) \\ \theta(E(y_j)) &= -[j][p-s-j]\theta(y_{j-1}) = -[j][p-s-j](f_{j-1}^y y_{j-1} + g_{j-1}^x x_{j-1})\end{aligned}$$

which means $f_j^y = f_{j-1}^y$, $g_j^x = g_{j-1}^x$, and hence $\theta(y_j) = f_{p-s-1}^y y_j$.

By a similar argument we get $\theta(x_j) = f_0^x x_j$.

As $E(y_0) = a_{s-1}$, we then have:

$$\begin{aligned}E(\theta(y_0)) &= f_{p-s-1}^y E(y_0) = f_{p-s-1}^y a_{s-1} \\ \theta(E(y_0)) &= \theta(a_{s-1}) = f_{s-1}^a a_{s-1} + g_{s-1}^b b_{s-1}\end{aligned}$$

and so $f_{s-1}^a = f_{p-s-1}^y$, $g_{s-1}^b = 0$, which gives $\theta(a_{s-1}) = f_{p-s-1}^y a_{s-1}$.

Similarly, as $F(x_{p-s-1}) = a_0$, we get $\theta(a_0) = f_0^x a_0$.

Given $F(a_i) = a_{i+1}$, $F(b_i) = b_{i+1}$, we then have:

$$\begin{aligned}F(\theta(a_i)) &= F(f_i^a a_i + g_i^b b_i) = f_i^a a_{i+1} + g_i^b b_{i+1} \\ \theta(F(a_i)) &= \theta(a_{i+1}) = f_{i+1}^a a_{i+1} + g_{i+1}^b b_{i+1}\end{aligned}$$

which gives $f_i^a = f_{i+1}^a$, $g_i^b = g_{i+1}^b$, and so $\theta(a_i) = f_0^x a_i$. This then gives $f_0^x = f_{p-s-1}^y$.

Hence we have now that the endomorphisms must be of the form:

$$\begin{aligned}\theta(a_i) &= f_0^x a_i & \theta(b_i) &= f_i^b b_i + g_i^a a_i \\ \theta(x_j) &= f_0^x x_j & \theta(y_j) &= f_0^y y_j\end{aligned}$$

Given $F(b_{s-1}) = y_0$, $F(a_{s-1}) = 0$, we have:

$$\begin{aligned} F(\theta(b_{s-1})) &= F(f_{s-1}^b b_{s-1} + g_{s-1}^a a_{s-1}) = f_{s-1}^b y_0 \\ \theta(F(b_{s-1})) &= \theta(y_0) = f_0^x y_0 \end{aligned}$$

then $f_{s-1}^b = f_0^x$.

Finally, given $F(b_i) = b_{i+1}$, we have:

$$\begin{aligned} F(\theta(b_i)) &= F(f_i^b b_i + g_i^a a_i) = f_i^b b_{i+1} + g_i^a a_{i+1} \\ \theta(F(b_i)) &= \theta(b_{i+1}) = f_{i+1}^b b_{i+1} + g_{i+1}^a a_{i+1} \end{aligned}$$

which gives $f_i^b = f_{i+1}^b$, $g_i^a = g_{i+1}^a$, and so $\theta(b_i) = f_0^x b_i + g_i^a a_i$.

Hence any endomorphism on \mathcal{P}_s^\pm can be written in terms of the identity map and ε , where $\varepsilon(b_i) = a_i$, $\varepsilon(a_i) = \varepsilon(x_j) = \varepsilon(y_j) = 0$, $\varepsilon^2 = 0$. \square

4.4.2 Homomorphisms between projective and simple modules.

As the actions on positive and negative modules differ only by a minus sign, we only need consider the cases:

$$\begin{aligned} \mathcal{P}_s^+ &\rightarrow \mathcal{X}_t^+ \\ \mathcal{X}_t^+ &\rightarrow \mathcal{P}_s^+ \\ \mathcal{P}_s^+ &\rightarrow \mathcal{X}_t^- \\ \mathcal{X}_t^- &\rightarrow \mathcal{P}_s^+ \end{aligned}$$

Homomorphisms $\theta : \mathcal{P}_s^+ \rightarrow \mathcal{X}_t^+$

Let \mathcal{P}_s^+ have basis $\{a_0, \dots, a_{s-1}, b_0, \dots, b_{s-1}\} \cup \{x_0, \dots, x_{p-s-1}, y_0, \dots, y_{p-s-1}\}$ and \mathcal{X}_t^+ have basis $\{z_0, \dots, z_{t-1}\}$.

Proposition 4.2. *The homomorphism $\theta : \mathcal{P}_s^+ \rightarrow \mathcal{X}_t^+$ is only non-zero when $s = t$ and has the form:*

$$\begin{aligned} \theta(a_i) &= \theta(x_j) = \theta(y_j) = 0 \\ \theta(b_i) &= f z_i \end{aligned}$$

for all $1 \leq i \leq s-1$, $1 \leq j \leq p-s-1$ and $f \in \mathbb{K}$.

Proof. We start by noting the K -action is given by:

$$\begin{aligned} K(x_j) &= -q^{p-s-1-2j}x_j & K(y_j) &= -q^{p-s-1-2j}a_i \\ K(a_i) &= q^{s-1-2i}a_i & K(b_i) &= q^{s-1-2i}b_i \\ K(z_k) &= q^{t-1-2k}z_k \end{aligned}$$

Consider the general form of θ :

$$\begin{aligned} \theta(x_j) &= \sum_{k=0}^{t-1} f_{j,k}^x z_k & \theta(y_j) &= \sum_{k=0}^{t-1} f_{j,k}^y z_k \\ \theta(a_i) &= \sum_{k=0}^{t-1} f_{i,k}^a z_k & \theta(b_i) &= \sum_{k=0}^{t-1} f_{i,k}^b z_k \end{aligned}$$

Starting with x_j , as both $E x_0 = 0$, $E z_0 = 0$, but $E z_k \neq 0$ for $1 \leq k \leq t-1$, then we must have $f_{0,k}^x = 0$, for $1 \leq k \leq t-1$. As any map must preserve K -weights, we have $K x_0 = -q^{p-s-1}$, $K z_0 = q^{t-1}$, hence we need $2p - s - 1 = t - 1 \pmod{2p}$ which requires $t = -s \pmod{2p}$. However this has no solution, therefore $f_{0,0}^x = 0$. For any other $f_{j,k}^x$, we have:

$$\theta(x_j) = \theta(F^j x_0) = F^j \theta(x_0) = 0$$

Hence $\theta(x_j) = 0$ for all j . A similar argument gives $\theta(y_j) = 0$ for all j .

For $\theta(a_i)$, we have:

$$\theta(a_i) = \theta(F^{i+1} x_{p-s-1}) = F^{i+1} \theta(x_{p-s-1}) = 0$$

Hence $\theta(a_i) = 0$ for $0 \leq i \leq s-1$. Finally, for $\theta(b_i)$, we have:

$$\begin{aligned} E(\theta(b_0)) &= \sum_{k=0}^{t-1} f_{0,k}^b E z_k = \sum_{k=1}^{t-1} f_{0,k}^b [k][t-k] z_{k-1} \\ \theta(E(b_0)) &= \theta(x_{p-s-1}) = 0 \end{aligned}$$

which means $f_{0,k}^b = 0$ for $1 \leq k \leq t-1$, and so $\theta(b_0) = f_{0,0}^b z_0$. Hence we have:

$$\theta(b_i) = \theta(F^i b_0) = F^i \theta(b_0) = f_{0,0}^b z_i$$

We need the K -actions to match, and so we need $q^{s-1} = q^{t-1}$ which means $s-1 = t-1 \pmod{2p}$, and therefore $s = t$. \square

Homomorphisms $\Gamma : \mathcal{X}_t^+ \rightarrow \mathcal{P}_s^+$

Proposition 4.3. *The homomorphism $\Gamma : \mathcal{X}_t^+ \rightarrow \mathcal{P}_s^+$ is only non-zero when $s = t$ and has the form:*

$$\Gamma(z_i) = g a_i$$

for all i and $g \in \mathbb{K}$.

Proof. Consider the general form for Γ :

$$\Gamma(z_k) = \sum_{i=0}^{s-1} \sum_{j=0}^{p-s-1} g_{k,i}^a a_i + g_{k,i}^b b_i + g_{k,j}^x x_j + g_{k,j}^y y_j$$

As $Ez_0 = Fz_{t-1} = 0$, we have:

$$\begin{aligned} E(\Gamma(z_0)) &= \sum_{i=1}^{s-1} \sum_{j=1}^{p-s-1} ([i][s-i]g_{0,i}^a + g_{0,i}^b)a_{i-1} + [i][s-i]g_{0,i}^b b_{i-1} \\ &\quad - [j][p-s-j]g_{0,j}^x x_{j-1} - [j][p-s-j]g_{0,j}^y y_j + g_{0,0}^b x_{p-s-1} + g_{0,0}^y a_{s-1} \\ &= 0 \\ \Gamma(z_0) &= g_{0,0}^a a_0 + g_{0,0}^x x_0 \end{aligned}$$

As they have different weights, either $g_{0,0}^a = 0$ or $g_{0,0}^x = 0$. We have $Kz_0 = q^{t-1}z_0$, $Ka_0 = q^{s-1}a_0$, $Kx_0 = -q^{p-s-1}x_0$. For x_0 , we need $2p-s-1 = t-1 \pmod{2p}$, which requires $s = -t \pmod{2p}$, which has no solution. Hence $g_{0,0}^x = 0$. For a_0 , we need $s-1 = t-1 \pmod{2p}$ which gives $s = t$. Hence we have:

$$\begin{aligned} \Gamma(z_0) &= g_{0,0}^a a_0 \\ \Gamma(z_k) &= \Gamma(F^k z_0) = F^k \Gamma(z_0) = g_{0,0}^a a_k \\ &0 \leq k \leq s-1 \end{aligned}$$

□

Homomorphisms $\theta : \mathcal{P}_s^+ \rightarrow \mathcal{X}_t^-$

Proposition 4.4. *There are no non-zero homomorphisms $\theta : \mathcal{P}_s^+ \rightarrow \mathcal{X}_t^-$.*

Proof. Consider the general form of θ :

$$\begin{aligned} \theta(x_j) &= \sum_{k=0}^{t-1} f_{j,k}^x z_k & \theta(y_j) &= \sum_{k=0}^{t-1} f_{j,k}^y z_k \\ \theta(a_i) &= \sum_{k=0}^{t-1} f_{i,k}^a z_k & \theta(b_i) &= \sum_{k=0}^{t-1} f_{i,k}^b z_k \end{aligned}$$

By considering the E -action on a_0 , we have $\theta(a_0) = f_{0,0}^a z_0$, however comparing K -weights, we have $Ka_0 = q^{s-1}a_0$, $Kz_0 = -q^{t-1}z_0$. This gives $f_{0,0}^a = 0$. From this, we have:

$$\theta(a_i) = \theta(F^i a_0) = F^i \theta(a_0) = 0$$

The other options for mapping to z_0 are x_0, b_0 , and y_0 , however again from the K -weights, we must have $\theta(b_0) = 0$. For x_0 and y_0 , the weights force $t = p - s$. However, as $Eb_0 = x_{p-s-1}$, $Fb_{s-1} = y_0$, we then have:

$$\begin{aligned}\theta(x_0) &= f_{0,0}^x z_0 \\ \theta(x_j) &= F^j \theta(x_0) = f_{0,0}^x F^j z_0 = f_{0,0}^x z_j \\ f_{0,0}^x z_{p-s-1} &= \theta(x_{p-s-1}) = \theta(E(b_0)) = E(\theta(b_0)) = 0\end{aligned}$$

which gives $f_{0,0}^x = 0$, and so $\theta(x_j) = 0$.

A similar argument gives $\theta(y_j) = 0$, and hence $\theta = 0$. □

Homomorphisms $\Gamma : \mathcal{X}_t^- \rightarrow \mathcal{P}_s^+$

Proposition 4.5. *There are no non-zero homomorphisms $\Gamma : \mathcal{X}_t^- \rightarrow \mathcal{P}_s^+$.*

Proof. Consider the general form of Γ :

$$\Gamma(z_k) = \sum_{i=0}^{s-1} \sum_{j=0}^{p-s-1} g_{k,i}^a a_i + g_{k,i}^b b_i + g_{k,j}^x x_j + g_{k,j}^y y_j$$

Then as $Ez_0 = 0$, we have:

$$\begin{aligned}E(\Gamma(z_0)) &= \sum_{i=1}^{s-1} \sum_{j=1}^{p-s-1} ([i][s-i]g_{0,i}^a + g_{0,i}^b)a_{i-1} + [i][s-i]g_{0,i}^b b_{i-1} \\ &\quad - [j][p-s-j]g_{0,j}^x x_{j-1} - [j][p-s-j]g_{0,j}^y y_j + g_{0,0}^b x_{p-s-1} + g_{0,0}^y a_{s-1} \\ &= 0\end{aligned}$$

$$\Gamma(z_0) = g_{0,0}^a a_0 + g_{0,0}^x x_0$$

Comparing weight spaces, we have $Kz_0 = -q^{t-1}z_0$, $Ka_0 = q^{s-1}a_0$, $Kx_0 = -q^{p-s-1}x_0$. From the first case, we have that the only possibility is $g_{0,0}^a = 0$. For the second case, we have $p - s - 1 = t - 1 \pmod{2p}$, which means $t = p - s$. However, as $Fx_{p-s-1} = a_0$, this then gives:

$$\begin{aligned}\Gamma(z_k) &= \Gamma(F^k z_0) = F^k \Gamma(z_0) = g_{0,0}^x x_k \\ F^{p-s} \Gamma(z_0) &= g_{0,0}^x a_0 = \Gamma(F^{p-s} z_0) = 0\end{aligned}$$

which gives $g_{0,0}^x = 0$, and so $\Gamma(z_0) = 0$.

We then have $\Gamma(z_k) = \Gamma(F^k z_0) = F^k \Gamma(z_0) = 0$, and hence $\Gamma = 0$. □

4.4.3 Homomorphisms between projective modules

Homomorphisms $\theta : \mathcal{P}_s^+ \rightarrow \mathcal{P}_t^+$

Let $\theta : \mathcal{P}_s^+ \rightarrow \mathcal{P}_t^+$. Denote the elements of \mathcal{P}_t^+ by $\tilde{a}_i, \tilde{b}_i, \tilde{x}_i, \tilde{y}_i$.

Proposition 4.6. *There are no non-zero homomorphisms $\theta : \mathcal{P}_s^+ \rightarrow \mathcal{P}_t^+$ except when $s = t$.*

Proof. From the E and F actions, the only possibilities for θ acting on the sub-basis $\{a_0, b_0\}$ are either $\{a_0, b_0\} \mapsto \{\tilde{a}_0, \tilde{b}_0\}$ or $\{a_0, b_0\} \mapsto \{\tilde{x}_0, \tilde{y}_0\}$. However, comparing K -weights, we have:

$$Ka_0 = q^{s-1}a_0 \quad K\tilde{a}_0 = q^{t-1}\tilde{a}_0 \quad K\tilde{x}_0 = -q^{p-t-1}\tilde{x}_0$$

Hence we have either $s - 1 = t - 1 \pmod{2p}$, which gives $s = t$, or else $s - 1 = 2p - t - 1 \pmod{2p}$, which reduces to $s = -t \pmod{2p}$, which has no solution. Hence the only non-zero case for θ is when $s = t$, which reduces to the endomorphisms on \mathcal{P}_s^+ given previously. \square

Homomorphisms $\theta : \mathcal{P}_s^+ \rightarrow \mathcal{P}_t^-$

Proposition 4.7. *The only non-zero homomorphisms of the form $\theta : \mathcal{P}_s^+ \rightarrow \mathcal{P}_t^-$ occur when $t = p - s$ and is given by:*

$$\begin{aligned} \theta(a_i) &= 0 \\ \theta(b_i) &= f_1\tilde{x}_i + f_2\tilde{y}_i \\ \theta(x_j) &= f_2\tilde{a}_j \\ \theta(y_j) &= f_1\tilde{a}_j \end{aligned}$$

for $1 \leq i \leq s - 1$, $1 \leq j \leq p - s - 1$, and $f_1, f_2 \in \mathbb{K}$.

Proof. Again from the E and F actions, the only possibilities for θ acting on $\{a_0, b_0\}$ are either $\{a_0, b_0\} \mapsto \{\tilde{a}_0, \tilde{b}_0\}$ or $\{a_0, b_0\} \mapsto \{\tilde{x}_0, \tilde{y}_0\}$. Comparing K -weights, we have:

$$Ka_0 = q^{s-1}a_0 \quad K\tilde{a}_0 = -q^{t-1}\tilde{a}_0 \quad K\tilde{x}_0 = q^{p-t-1}\tilde{x}_0$$

Hence either $s - 1 = p + t - 1 \pmod{2p}$, which reduces to $s = p + t \pmod{2p}$, which has no solution, or else $s - 1 = p - t - 1 \pmod{2p}$ which gives $t = p - s$. θ must then have the

general form:

$$\begin{aligned}\theta(a_i) &= f_i^{a,x} \tilde{x}_i + f_i^{a,y} \tilde{y}_i & \theta(b_i) &= f_i^{b,x} \tilde{x}_i + f_i^{b,y} \tilde{y}_i \\ \theta(x_j) &= f_j^{x,a} \tilde{a}_j + f_j^{x,b} \tilde{b}_j & \theta(y_j) &= f_j^{y,a} \tilde{a}_j + f_j^{y,b} \tilde{b}_j \\ 0 \leq i &\leq s-1 & 0 \leq j &\leq p-s-1\end{aligned}$$

We have:

$$\begin{aligned}0 &= \theta(E(a_0)) = E(\theta(a_0)) = E(f_0^{a,x} \tilde{x}_0 + f_0^{a,y} \tilde{y}_0) \\ &= f_0^{a,y} \tilde{a}_{p-s-1}\end{aligned}$$

and so $f_0^{a,y} = 0$, which gives $\theta(a_0) = f_0^{a,x} \tilde{x}_0$.

We then have $\theta(a_i) = f_0^{a,x} \tilde{x}_i$ for all i , however:

$$0 = \theta(F(a_{s-1})) = F\theta(a_{s-1}) = f_0^{a,x} F\tilde{x}_{s-1} = f_0^{a,x} \tilde{a}_0$$

hence $f_0^{a,x} = 0$, and therefore $\theta(a_i) = 0$ for all i .

Next, we have:

$$0 = \theta(E(x_0)) = E(\theta(x_0)) = E(f_0^{x,a} \tilde{a}_0 + f_0^{x,b} \tilde{b}_0) = f_0^{x,b} \tilde{x}_{s-1}$$

therefore $f_0^{x,b} = 0$, which gives $\theta(x_0) = f_0^{x,a} \tilde{a}_0$, and $\theta(x_i) = f_0^{x,a} \tilde{a}_i$.

Similarly, we get $\theta(y_i) = f_{s-1}^{y,a} \tilde{a}_i$.

Next, as $Eb_0 = x_{p-s-1}$, we have:

$$\begin{aligned}f_0^{x,a} \tilde{a}_{p-s-1} &= \theta(E(b_0)) = E(\theta(b_0)) = E(f_0^{b,x} \tilde{x}_0 + f_0^{b,y} \tilde{y}_0) = f_0^{b,y} \tilde{a}_{p-s-1} \\ f_0^{x,a} &= f_0^{b,y} \\ f_i^{b,x} \tilde{x}_i + f_i^{b,y} \tilde{y}_i &= \theta(F^i(b_0)) = F^i(\theta(b_0)) = f_0^{b,x} \tilde{x}_i + f_0^{b,y} \tilde{y}_i \\ \theta(b_i) &= f_0^{b,x} \tilde{x}_i + f_0^{b,y} \tilde{y}_i\end{aligned}$$

As $Fb_{s-1} = y_0$, we have:

$$\begin{aligned}f_{s-1}^{y,a} \tilde{a}_{p-s-1} &= \theta(F(b_{s-1})) = F(\theta(b_{s-1})) = F(f_0^{b,x} \tilde{x}_{s-1} + f_0^{b,y} \tilde{y}_{s-1}) = f_0^{b,x} \tilde{x}_{s-1} \\ f_{s-1}^{y,a} &= f_0^{b,x}\end{aligned}$$

Hence we have the general form of θ is:

$$\begin{aligned}\theta(a_i) &= 0 & \theta(b_i) &= f_0^{b,x} \tilde{x}_i + f_0^{b,y} \tilde{y}_i \\ \theta(x_j) &= f_0^{b,y} \tilde{a}_j & \theta(y_j) &= f_0^{b,x} \tilde{a}_j\end{aligned}$$

□

Chapter 5

The $\bar{U}_q(\mathfrak{sl}_2)$ Planar Algebra.

Our construction of the $\bar{U}_q(\mathfrak{sl}_2)$ planar algebra is a diagrammatic description of $End((\mathcal{X}_2^+)^{\otimes n})$, similar to the constructions of [20, 24, 43, 47]. We will show that for $n < 2p - 1$, this is equivalent to the Temperley-Lieb algebra on n points with parameter $\delta = q + q^{-1}$, and for $n \geq 2p - 1$, $End((\mathcal{X}_2^+)^{\otimes n})$ contains an extension of the Temperley-Lieb algebra by two extra generators. The main focus of this chapter is theorem 5.2, which describes a number of relations on the extra generators of the $\bar{U}_q(\mathfrak{sl}_2)$ planar algebra. This is not a complete list of relations, but we believe that any other relations should come from a generalization of the ones given, mainly relations 5.15, 5.17, 5.21, and 5.22. For the case, $p = 2$, $n = 4$, theorem 5.2 gives a complete list of relations. A proof of a complete list of generators and relations for the $\bar{U}_q(\mathfrak{sl}_2)$ planar algebra is a potential future endeavour. For the rest of this chapter, we denote $X := \mathcal{X}_2^+$.

The module X has basis $\{\nu_0, \nu_1\}$, with $\bar{U}_q(\mathfrak{sl}_2)$ action:

$$\begin{array}{lll} K(\nu_0) = q\nu_0 & E(\nu_0) = 0 & F(\nu_0) = \nu_1 \\ K(\nu_1) = q^{-1}\nu_1 & E(\nu_1) = \nu_0 & F(\nu_1) = 0 \end{array}$$

The action of $\bar{U}_q(\mathfrak{sl}_2)$ on $X^{\otimes n}$ is given by use of the coproduct.

We denote by $\rho_{i_1, \dots, i_n, z}$ the element of $X^{\otimes z}$ with ν_1 at positions i_1, \dots, i_n , and ν_0 elsewhere. We also occasionally omit the \otimes sign, and combine indices. For example,

$$\rho_{1,3,5} = \nu_1 \otimes \nu_0 \otimes \nu_1 \otimes \nu_0 \otimes \nu_0 = \nu_{10100}.$$

The elements of $X^{\otimes z}$ can be described in terms of the K -action on them. For $x \in X^{\otimes z}$, with $K(x) = \lambda x$, $\lambda \in \mathbb{K}$, we call λ the weight of x . Alternatively for basis elements we can write this as $K(\rho_{i_1, \dots, i_n, z}) = q^{z-2n}x$, and refer to n also as the weight. $X^{\otimes z}$ will then have

the set of weights $\{q^z, q^{z-2}, \dots, q^{2-z}, q^{-z}\}$. Denoting the set of elements of $X^{\otimes z}$ with weight q^{z-2n} by $X_{n,z}$, we have $X^{\otimes z} = \bigcup_{i=0}^z X_{i,z}$. The weight spaces $X_{0,z}$ $X_{z,z}$ both have a single element, which we denote by $x_{0,z} := (\nu_0)^{\otimes z}$, $x_{z,z} := (\nu_1)^{\otimes z}$ respectively, and occasionally drop the second index if the context is clear. We have $\rho_{i_1, \dots, i_n, z} \in X_{n,z}$.

We record a number of combinatorial relations involving $\bar{U}_q(\mathfrak{sl}_2)$ and its action on $X^{\otimes z}$ in Appendix A.

The module $\mathcal{X}_1^+ \simeq \mathbb{K}$ has basis $\{\nu\}$ and action:

$$K(\nu) = \nu \qquad E(\nu) = 0 \qquad F(\nu) = 0 \qquad (5.1)$$

5.1 The Temperley-Lieb Algebra

The aim of this section is to prove the following:

Theorem 5.1. $End(X^{\otimes n}) \simeq TL_n(q + q^{-1})$, $n < 2p - 1$

Proof. In section 4.3, we showed that the dimension of $End(X^{\otimes n})$ is equal to the dimension of $TL_n(q + q^{-1})$ for $n < 2p - 1$. Hence we just need to show that $End(X^{\otimes n})$ has a set of generators satisfying the same properties as the Temperley-Lieb generators.

We define the following maps $\cup : X^{\otimes 2} \rightarrow \mathcal{X}_1^+$, $\cap : \mathcal{X}_1^+ \rightarrow X^{\otimes 2}$ by:

$$\cup(\nu_{10}) = \nu \qquad (5.2)$$

$$\cup(\nu_{01}) = -q\nu \qquad (5.3)$$

$$\cup(\nu_{00}) = \cup(\nu_{11}) = 0 \qquad (5.4)$$

$$\cap(\nu) = q^{-1}\nu_{10} - \nu_{01} \qquad (5.5)$$

where ν is the basis of \mathcal{X}_1^+ .

We define $\tilde{e}_i := 1^{\otimes(i-1)} \otimes (\cap \cup) \otimes 1^{\otimes(n-i-1)} \in End(X^{\otimes n})$. Then the maps $\tilde{e}_1, \dots, \tilde{e}_{n-1}$ satisfy the Temperley-Lieb relations. \square

These \tilde{e}_i act as $\tilde{e}(\nu_{00}) = \tilde{e}(\nu_{11}) = 0$, $\tilde{e}(\nu_{10}) = q^{-1}\nu_{10} - \nu_{01}$, $\tilde{e}(\nu_{01}) = q\nu_{01} - \nu_{10}$. From this we can see that the \tilde{e}_i act on weight spaces as $\tilde{e}_i : X_{k,n} \rightarrow X_{k,n}$, and hence any element of $End(X^{\otimes n})$ for $n < 2p - 1$ must map weight spaces to themselves.

The Temperley-Lieb algebra contains a set of projections known as the Jones-Wenzl projections. The n th Jones-Wenzl projection, f_n , for $0 \leq n \leq p - 1$, is the unique projection

satisfying:

$$f_n : X^{\otimes n} \rightarrow \mathcal{X}_{n+1}^+ \rightarrow X^{\otimes n}$$

Details on this are given in Appendix B.

5.2 The $\bar{U}_q(\mathfrak{sl}_2)$ Planar Algebra

The $\bar{U}_q(\mathfrak{sl}_2)$ planar algebra, with $q = e^{i\pi/p}$ and $2 \leq p \in \mathbb{N}$, is a diagrammatic description of $End(X^{\otimes n})$. An element of $End(X^{\otimes n})$ is given by a planar box with n points along the top and n points along the bottom. More generally, an element of $Hom(X^{\otimes m}, X^{\otimes n})$ is a planar box with m points along the top and n points along the bottom. A box with zero points along an edge is used to represent a map to or from \mathcal{X}_1^+ , with our choice of these maps defined by equations 5.2 - 5.5. The identity map in $End(X^{\otimes n})$ is given by n vertical strings, and the identity map on \mathcal{X}_1^+ is given by an empty box. We sometimes denote multiple parallel strings by a single thick string, and omit the external box.

Some basic examples are:

$$1 : \mathcal{X}_1^+ \rightarrow \mathcal{X}_1^+ :=$$

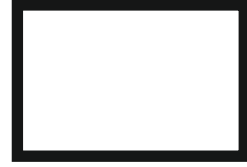

$$\mathcal{X}_2^+ \otimes \mathcal{X}_2^+ \rightarrow \mathcal{X}_1^+ :=$$

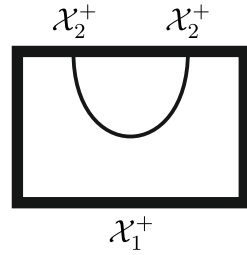

$$1 : \mathcal{X}_2^+ \rightarrow \mathcal{X}_2^+ :=$$



Our $\bar{U}_q(\mathfrak{sl}_2)$ planar algebra construction is given by the Temperley-Lieb algebra with $\delta = q + q^{-1}$, and two $(2p - 1)$ -box generators α, β , which are defined in section 5.3. We

denote by α_i, β_i the elements $1^{\otimes(i-1)} \otimes \alpha \otimes 1^{(n-2p-i-2)}, 1^{(i-1)} \otimes \beta \otimes 1^{(n-2p-i-2)} \in \text{End}(X^{\otimes n})$, $n \geq 2p - 1$.

Theorem 5.2. *The generators α and β of the $\bar{U}_q(\mathfrak{sl}_2)$ planar algebra satisfy the following properties:*

$$\alpha^2 = \beta^2 = 0 \quad (5.6)$$

$$\alpha\beta\alpha = \gamma\alpha \quad (5.7)$$

$$\beta\alpha\beta = \gamma\beta \quad (5.8)$$

$$\gamma = (-1)^{p-1}([p-1]!)^2 \quad (5.9)$$

$$\alpha_i\alpha_j = \alpha_j\alpha_i = \beta_i\beta_j = \beta_j\beta_i = 0, \quad |i-j| < p \quad (5.10)$$

$$\alpha_i\alpha_{i+p} = \alpha_{i+p}\alpha_i \quad (5.11)$$

$$\beta_i\beta_{i+p} = \beta_{i+p}\beta_i \quad (5.12)$$

$$\alpha\beta + \beta\alpha = \gamma\mathfrak{f}_{2p-1} \quad (5.13)$$

We denote by \cup_i, \cap_i the corresponding maps, (equations 5.2 - 5.5), acting on the i th and $(i+1)$ th points. Denote by R_n the (clockwise) (n,n) -point annular rotation tangle. We then have:

$$\alpha\cap_i = \cup_i\alpha = \beta\cap_i = \cup_i\beta = 0, \quad 1 \leq i \leq 2p-2 \quad (5.14)$$

$$\alpha_{i+1}\cap_i = \alpha_i\cap_{i+2p-2} \quad (5.15)$$

$$\cup_i\alpha_{i+1} = \cup_{i+2p-2}\alpha_i \quad (5.16)$$

$$\beta_{i+1}\cap_i = \beta_i\cap_{i+2p-2} \quad (5.17)$$

$$\cup_i\beta_{i+1} = \cup_{i+2p-2}\beta_i \quad (5.18)$$

$$R_{4p-2}(\alpha) = \alpha \quad (5.19)$$

$$R_{4p-2}(\beta) = \beta \quad (5.20)$$

$$\sum_{i=0}^{4p-1} k_i R_{4p}^i(\alpha \otimes 1) = 0 \quad (5.21)$$

$$\sum_{i=0}^{4p-1} k_i R_{4p}^i(\beta \otimes 1) = 0 \quad (5.22)$$

where $k_i = (-1)^i[i-2]k_1 + (-1)^i[i-1]k_2$, for arbitrary $k_1, k_2 \in \mathbb{K}$.

Diagrammatically, these relations are:

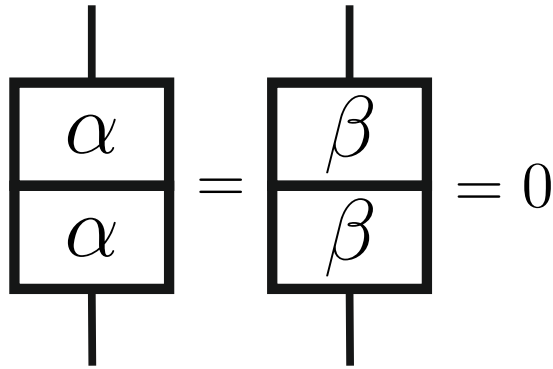

Figure 5.1: Relation 5.6

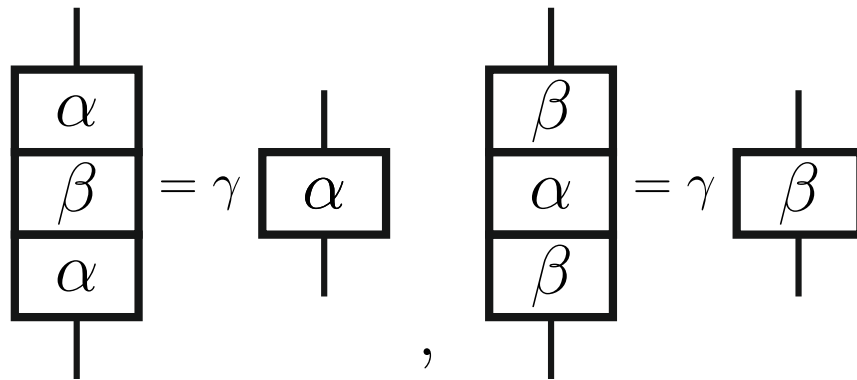

Figure 5.2: Relation 5.7 and 5.8

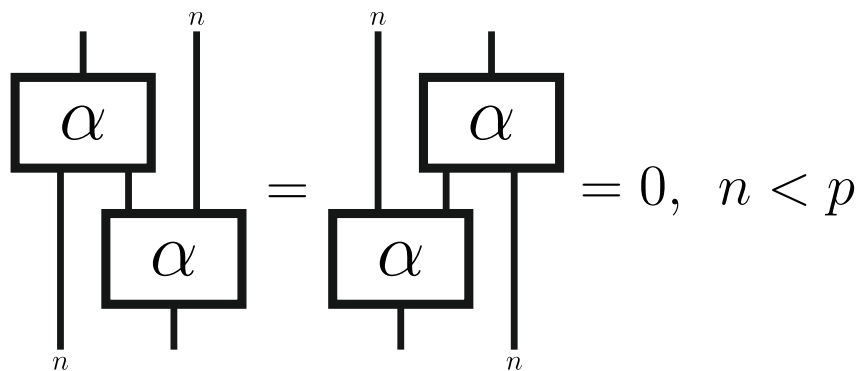

Figure 5.3: Relation 5.10

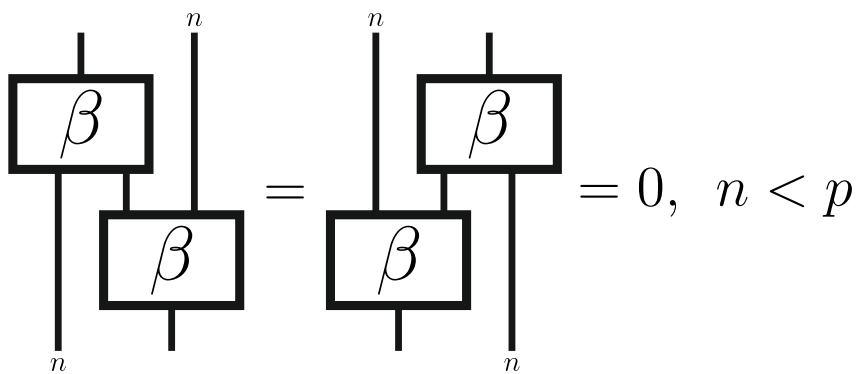

Figure 5.4: Relation 5.10

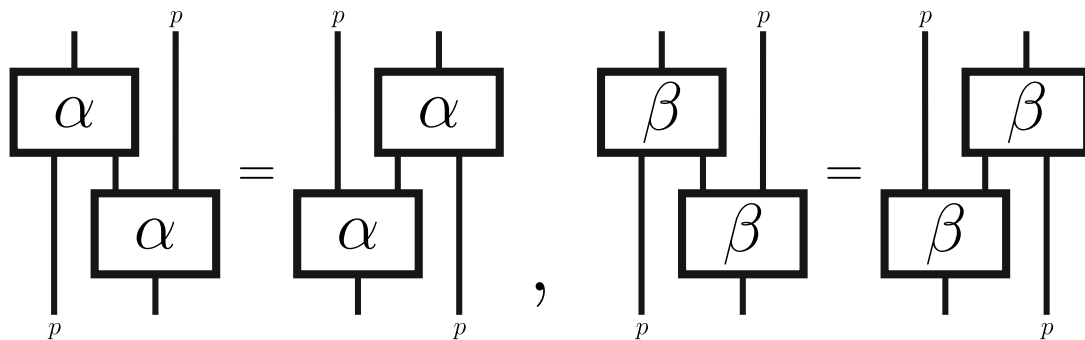

Figure 5.5: Relation 5.11 and 5.12

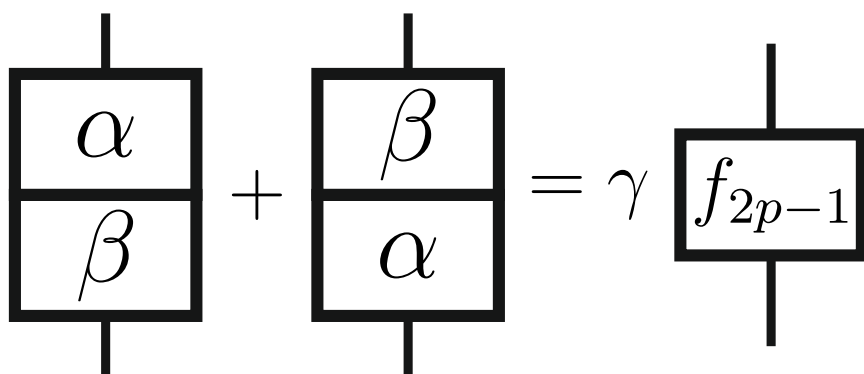

Figure 5.6: Relation 5.13

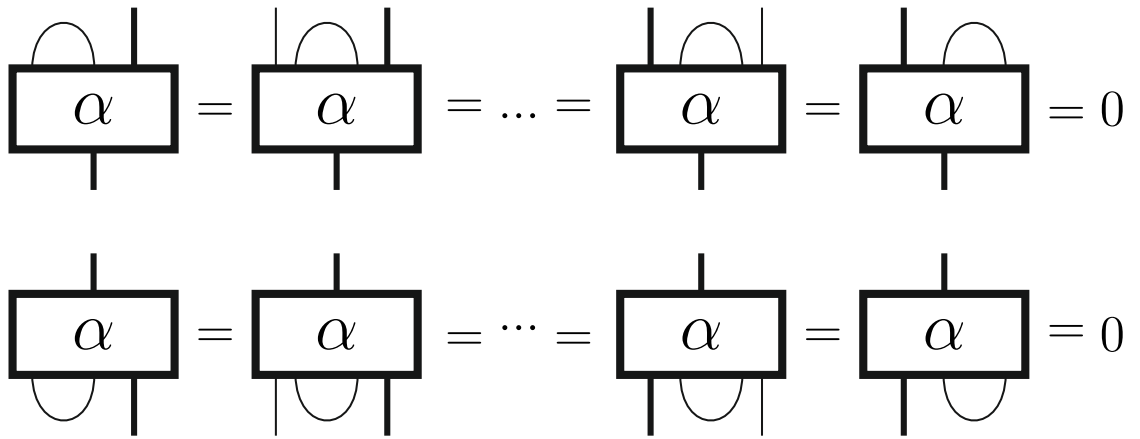

Figure 5.7: Relation 5.14

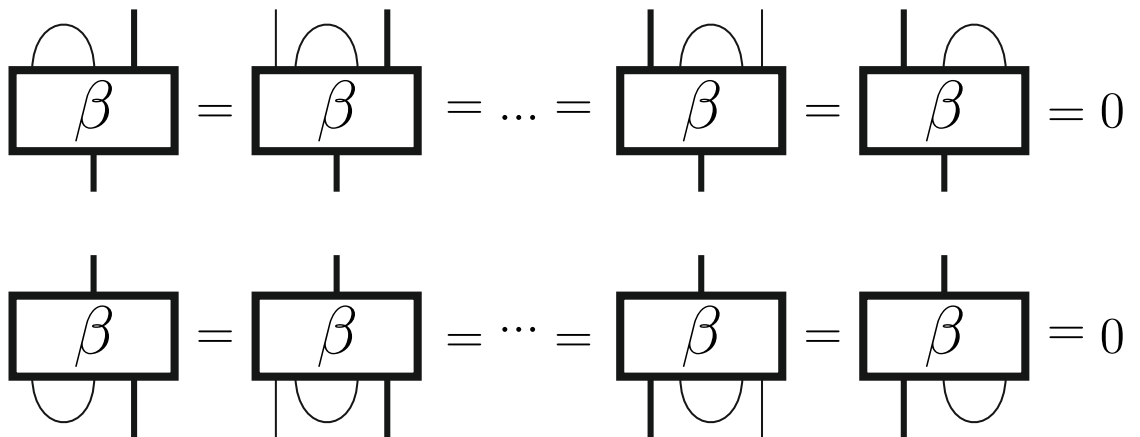

Figure 5.8: Relation 5.14

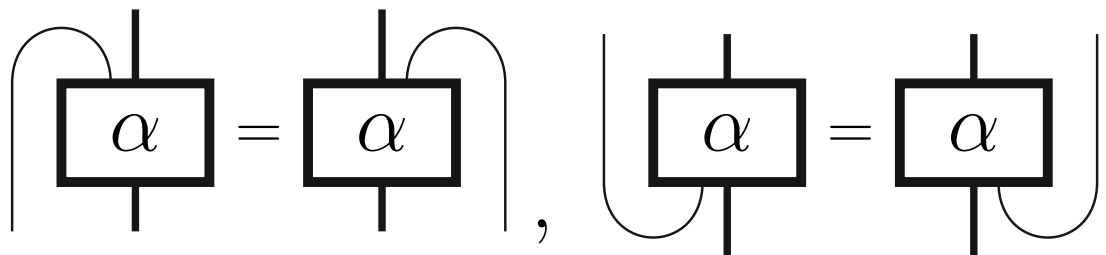

Figure 5.9: Relation 5.15 and 5.16

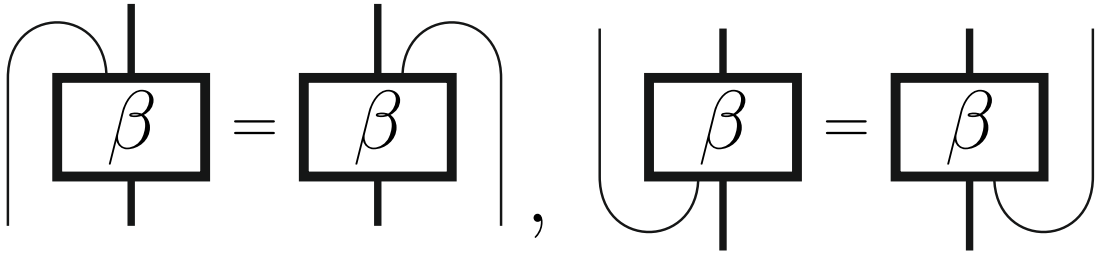

Figure 5.10: Relation 5.17 and 5.18

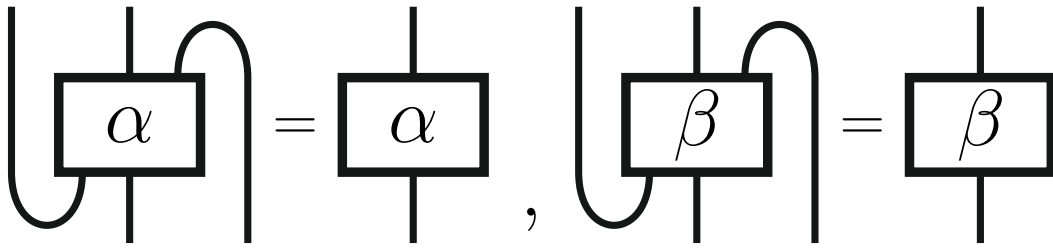

Figure 5.11: Relation 5.19 and 5.20

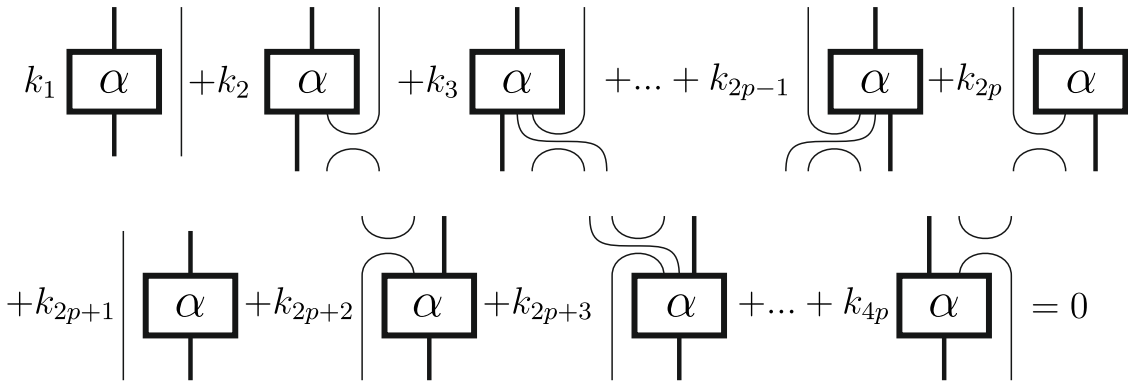

Figure 5.12: Relation 5.21

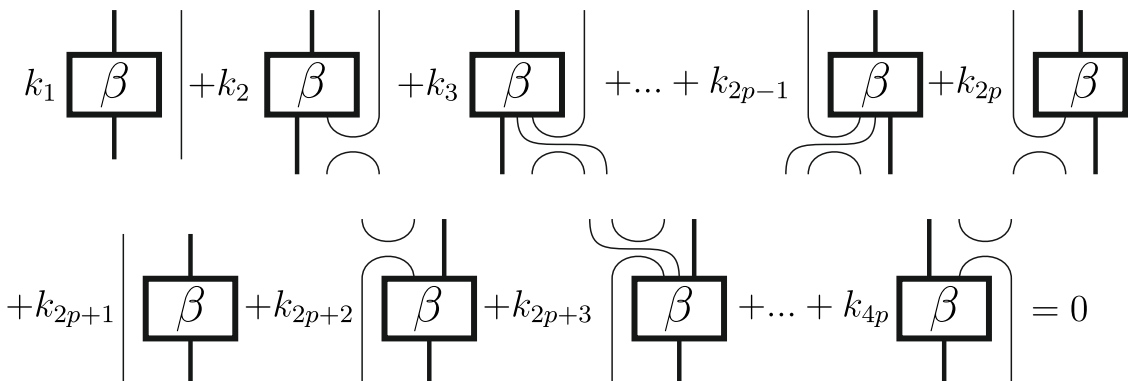

Figure 5.13: Relation 5.22

We also have the partial traces given by:

The diagram shows a sequence of four square boxes with two vertical lines passing through them. The first box contains the symbol α and has a loop on the top line. The second box contains α and has a loop on the bottom line. The third box contains β and has a loop on the top line. The fourth box contains β and has a loop on the bottom line. These four boxes are connected by equals signs, and the entire sequence is followed by an equals sign and the number 0.

Figure 5.14: The partial trace of α and β .

The top part of the diagram shows four square boxes, each divided into two horizontal sections. The first box has α in the top section and β in the bottom section, with a loop on the top line. The second box has β in the top section and α in the bottom section, with a loop on the bottom line. The third box has α in the top section and β in the bottom section, with a loop on the bottom line. The fourth box has β in the top section and α in the bottom section, with a loop on the top line. These four boxes are connected by equals signs. Below this sequence is an equals sign followed by the symbol $-\gamma$ and another diagrammatic representation of $-\gamma$, which consists of two vertical lines with two boxes labeled f_{p-1} on them, one on each line, connected by a loop.

Figure 5.15: The partial trace of $\alpha\beta$ and $\beta\alpha$.

The aim of the rest of this chapter will be to prove the existence of these generators and their relations. The formulae for the partial traces of $\alpha\beta$ and $\beta\alpha$ will be proven in section 6.6 of the following chapter.

5.3 The Generators α and β .

Let $x_0 \in X_{0,2p-1}$ and $x_{2p-1} \in X_{2p-1,2p-1}$, For any $x \in X_{k,2p-1}$, there is $e_x, f_x \in \mathbb{K}$ such that $E^k x = e_x x_0$ and $F^{2p-k-1} x = f_x x_{2p-1}$. We define the maps α, β by:

$$\begin{aligned}\alpha(x) &:= e_x E^{p-k-1} x_{2p-1} \\ \beta(x) &:= f_x F^{k-p} x_0\end{aligned}$$

where we take $E^{-1} = 0, F^{-1} = 0$. In terms of weight spaces, they act as:

$$\begin{aligned}\alpha : X_{k,2p-1} &\rightarrow X_{k+p,2p-1} \\ \beta : X_{k,2p-1} &\rightarrow X_{k-p,2p-1}\end{aligned}$$

Then α is zero for $k \geq p$ and β is zero for $k < p$. Hence $\alpha^2 = \beta^2 = 0$.

From their action on weight spaces, it's clear that $\alpha, \beta \notin TL_{2p-1}$. We want to prove that $\alpha, \beta \in \text{End}(X^{\otimes(2p-1)})$.

5.3.1 Proof of the commutivity of α and β with the $\bar{U}_q(\mathfrak{sl}_2)$ action.

We want to show that α and β commute with the action of $\bar{U}_q(\mathfrak{sl}_2)$, and so that $\alpha, \beta \in \text{End}(X^{\otimes(2p-1)})$. Starting with α , for commutivity with K we have:

$$\begin{aligned}\alpha(K(x)) &= q^{2p-1-2k} \alpha(x) = q^{2p-1-2k} e_x E^{p-k-1} x_{2p-1} = q^{-1-2k} e_x E^{p-k-1} x_{2p-1} \\ K(\alpha(x)) &= e_x K E^{p-k-1} x_{2p-1} = q^2 e_x E K E^{p-k-2} x_{2p-1} = q^{2p-2k-2} e_x E^{p-k-1} K x_{2p-1} \\ &= q^{2p-2k-2} q^{1-2p} e_x E^{p-k-1} x_{2p-1} = q^{-1-2k} e_x E^{p-k-1} x_{2p-1} = \alpha(K(x))\end{aligned}$$

Hence α commutes with K .

For the commutivity of α with E we need the following:

Let $E(x) = \frac{e_x}{e_v} v$, so that $E^{k-1} v = e_v x_0$, then:

$$\begin{aligned}\alpha(E(x)) &= \frac{e_x}{e_v} \alpha(v) = \frac{e_x}{e_v} e_v E^{p-k} x_{2p-1} = e_x E^{p-k} x_{2p-1} \\ E(\alpha(x)) &= e_x E(E^{p-k-1} x_{2p-1}) = e_x E^{p-k} x_{2p-1} = \alpha(E(x))\end{aligned}$$

Hence α commutes with E .

Finally for the commutivity of α with F , using equation A.8, we have:

$$\begin{aligned}
E^{k+1}F(x) &= (FE^{k+1} + (\frac{[k+1]}{q-q^{-1}}))(q^k E^k K - q^{-k} E^k K^{-1})x \\
&= (FE^{k+1} + (\frac{[k+1]}{q-q^{-1}}))(q^{-k} K E^k - q^k K^{-1} E^k)x \\
&= e_x(\frac{[k+1]}{q-q^{-1}})(q^{-k} K - q^k K^{-1})x_0 = e_x(\frac{[k+1]}{q-q^{-1}})(q^{2p-1-k} - q^{k+1-2p})x_0 \\
&= e_x[k+1][2p-1-k]x_0 \\
\alpha(F(x)) &= e_x[k+1][2p-1-k]E^{p-k-2}x_{2p-1} \\
F(\alpha(x)) &= e_x F E^{p-k-1} x_{2p-1} \\
&= e_x (E^{p-k-1} F + (\frac{[p-k-1]}{q-q^{-1}}))(q^{k-p+2} E^{p-k-2} K^{-1} - q^{p-k-2} E^{p-k-2} K)x_{2p-1} \\
&= e_x (\frac{[p-k-1]}{q-q^{-1}})(q^{k-p+2+2p-1} E^{p-k-2} - q^{p-k-2+1-2p} E^{p-k-2})x_{2p-1} \\
&= e_x (\frac{[p-k-1]}{q-q^{-1}})(q^{k+1+p} E^{p-k-2} - q^{-p-k-1} E^{p-k-2})x_{2p-1} \\
&= e_x [p-k-1][p+k+1] E^{p-k-2} x_{2p-1} \\
&= e_x [k+1][2p-k-1] E^{p-k-2} x_{2p-1}
\end{aligned}$$

Hence the identity holds for all $0 \leq k < p$, so we have shown that α commutes with F , and so the action of $\bar{U}_q(\mathfrak{sl}_2)$ commutes with α .

Hence we have that $\alpha \in \text{End}(X^{\otimes(2p-1)})$.

For commutivity of the action of $\bar{U}_q(\mathfrak{sl}_2)$ with β , starting with K we have:

$$\begin{aligned}
\beta(K(x)) &= q^{2p-1-2k} \beta(x) = q^{-1-2k} f_x F^{k-p} x_0 \\
K(\beta(x)) &= f_x K F^{k-p} x_0 = q^{-2} f_x F K F^{p-k-1} x_0 = q^{2p-2k} f_x F^{k-p} K x_0 \\
&= q^{2p-2k} q^{2p-1} f_x F^{k-p} x_0 = q^{-1-2k} f_x F^{k-p} x_0 = \beta(K(x))
\end{aligned}$$

Hence β commutes with K .

For commutivity with F we need the following:

Let $F(x) = \frac{f_x}{f_y} y$ so that $F^{2p-k-2}(y) = f_y x_{2p-1}$. We have:

$$\begin{aligned}
\beta(F(x)) &= \frac{f_x}{f_y} \beta(y) = f_x F^{k-p+1} x_0 \\
F(\beta(x)) &= f_x F F^{k-p}(x_0) = f_x F^{k-p+1} x_0 = \beta(F(x))
\end{aligned}$$

Hence β commutes with F .

Finally for the E action, using equation A.6, we have:

$$\begin{aligned}
F^{2p-k}E(x) &= (EF^{2p-k} + (\frac{[2p-k]}{q-q^{-1}})(q^{2p-k-1}F^{2p-k-1}K^{-1} - q^{1+k-2p}F^{2p-k-1}K))x \\
&= (EF^{2p-k} + (\frac{[2p-k]}{q-q^{-1}})(q^kF^{2p-k-1} - q^{-k}F^{2p-k-1}))x \\
&= f_x(\frac{[2p-k]}{q-q^{-1}})(q^k - q^{-k})x_{2p-1} = f_x[2p-k][k]x_{2p-1} \\
\beta(E(x)) &= f_x[2p-k][k]F^{k-p-1}x_0 \\
E(\beta(x)) &= f_xE(F^{k-p}x_0) \\
&= f_x(F^{k-p}E + (\frac{[k-p]}{q-q^{-1}})(q^{1-k+p}F^{k-p-1}K - q^{k-p-1}F^{k-p-1}K^{-1}))x_0 \\
&= f_x(\frac{[k-p]}{q-q^{-1}})(q^{1-k+p+2p-1}F^{k-p-1} - q^{k-p-1+1-2p}F^{k-p-1})x_0 \\
&= f_x(\frac{[k-p]}{q-q^{-1}})(q^{3p-k} - q^{k-3p})F^{k-p-1}x_0 \\
&= f_x[k-p][3p-k]F^{k-p-1}x_0 = f_x[2p-k][k]F^{k-p-1} = \beta(E(x))
\end{aligned}$$

Hence the identity holds for all $p \leq k \leq 2p$, and we have shown that β commutes with E , and so β commutes with the action of $\bar{U}_q(\mathfrak{sl}_2)$.

Hence $\beta \in \text{End}(X^{\otimes(2p-1)})$.

5.3.2 Proof that $\text{Im } \alpha \simeq \text{Im } \beta \simeq \mathcal{X}_p^-$.

We want to show that the images of the maps α and β are actually the module \mathcal{X}_p^- . We do this by constructing suitable bases from the images, similar to the construction of the simple modules from the highest weight vector. We then show that the action on each basis is the same as the action on \mathcal{X}_p^- .

Note that $\alpha(x_0) = E^{p-1}x_{2p-1}$, and that $K(\alpha(x_0)) = KE^{p-1}x_{2p-1} = q^{2p-2}E^{p-1}Kx_{2p-1} = q^{2p-2}q^{1-2p}E^{p-1}x_{2p-1} = q^{-1}\alpha(x_0) = -q^{p-1}\alpha(x_0)$. We have:

$$\begin{aligned}
F(\alpha(x_0)) &= FE^{p-1}x_{2p-1} = (E^{p-1}F + (\frac{[p-1]}{q-q^{-1}})(q^{2-p}E^{p-2}K^{-1} - q^{p-2}E^{p-2}K))x_{2p-1} \\
&= (E^{p-1}F + (\frac{[p-1]}{q-q^{-1}})(q^{p+1}E^{p-2} - q^{-1-p}E^{p-2}))x_{2p-1} \\
&= [p-1][p+1]E^{p-2}x_{2p-1} = -E^{p-2}x_{2p-1}
\end{aligned}$$

Define $w_0 := \alpha(x_0)$, $w_1 := F(\alpha(x_0)) = -E^{p-2}x_{2p-1}$, $w_k := F^k(\alpha(x_0))$. We want to show that $\{w_0, \dots, w_{p-1}\} \simeq \mathcal{X}_p^-$. We have:

$$\begin{aligned} K(w_k) &= KF^k(\alpha(x_0)) = KF^kE^{p-1}x_{2p-1} = q^{-2k}F^kKE^{p-1}x_{2p-1} \\ &= q^{-2k}q^{4p-2}F^kE^{p-1}Kx_{2p-1} = q^{-2k}q^{4p-2}q^{1-2p}F^kE^{p-1}x_{2p-1} \\ &= q^{-2k-1}y_k = -q^{p-1-2k}w_k \end{aligned}$$

$$F(w_k) = F^{k+1}(\alpha(x_0)) = w_{k+1}$$

$$F(w_{p-1}) = F^p(\alpha(x_0)) = 0$$

$$E(w_0) = E(\alpha(x_0)) = E^p x_{2p-1} = 0$$

Using equation A.6 we have:

$$\begin{aligned} E(w_k) &= EF^k(\alpha(x_0)) = EF^kE^{p-1}x_{2p-1} \\ &= (F^kE + \frac{[k]}{q-q^{-1}})(q^{1-k}F^{k-1}K - q^{k-1}F^{k-1}K^{-1})E^{p-1}x_{2p-1} \\ &= \frac{[k]}{q-q^{-1}}(q^{1-k}F^{k-1}K - q^{k-1}F^{k-1}K^{-1})E^{p-1}x_{2p-1} \\ &= \frac{[k]}{q-q^{-1}}(q^{1-k+2p-2+1-2p}F^{k-1} - q^{k-1+2-2p+2p-1}F^{k-1})E^{p-1}x_{2p-1} \\ &= \frac{[k]}{q-q^{-1}}(q^{-k}F^{k-1} - q^kF^{k-1})E^{p-1}x_{2p-1} \\ &= -[k]^2F^{k-1}E^{p-1}x_{2p-1} = -[k][p-k]F^{k-1}E^{p-1}x_{2p-1} \\ &= -[k][p-k]w_{k-1} \end{aligned}$$

Hence we have that the set of elements $\{w_0, \dots, w_{p-1}\}$ is isomorphic to the basis of \mathcal{X}_p^- , and so $Im \alpha \simeq \mathcal{X}_p^-$.

Define $z_{p-1} := \beta(x_{2p-1})$, $z_{k-1} := \frac{-1}{[k][p-k]}Ez_k$, letting $z_k = c_kE^{p-1-k}z_{p-1}$ where $c_k = \frac{(-1)^{p-1-k}([k]!)}{([p-1]!)([p-1-k]!)}$. We want to show that $\{z_0, \dots, z_{p-1}\} \simeq \mathcal{X}_p^-$. We have:

$$\begin{aligned} K(z_k) &= c_kKE^{p-1-k}z_{p-1} = c_kKE^{p-1-k}F^{p-1}x_0 = c_kq^{2p-2-2k}E^{p-1-k}KF^{p-1}x_0 \\ &= c_kq^{2p-2-2k}q^{2-2p}E^{p-1-k}F^{p-1}Kx_0 = c_kq^{-2k}q^{2p-1}E^{p-1-k}F^{p-1}x_0 \\ &= q^{-1-2k}z_k = -q^{p-1-2k}z_k \end{aligned}$$

$$E(z_k) = -[k][p-k]z_{k-1}$$

$$E(z_0) = c_0EE^{p-1}z_{p-1} = 0$$

$$F(z_{p-1}) = FF^{p-1}x_0 = 0$$

Using equation A.8 we have:

$$\begin{aligned}
F(z_k) &= c_k F E^{p-1-k} z_{p-1} = c_k F E^{p-1-k} (\beta(x_{2p-1})) = c_k F E^{p-1-k} F^{p-1} x_0 \\
&= c_k (E^{p-1-k} F + (\frac{[p-1-k]}{q-q^{-1}})(q^{k-p+2} E^{p-k-2} K^{-1} - q^{p-k-2} E^{p-k-2} K)) F^{p-1} x_0 \\
&= c_k (\frac{[p-1-k]}{q-q^{-1}})(q^{k-p+2+2p-2+1-2p} E^{p-k-2} - q^{p-k-2-2p+2+2p-1} E^{p-k-2}) F^{p-1} x_0 \\
&= c_k (\frac{[p-1-k]}{q-q^{-1}})(q^{k-p+1} E^{p-k-2} - q^{p-k-1} E^{p-k-2}) F^{p-1} x_0 \\
&= -c_k [p-1-k]^2 E^{p-k-2} F^{p-1} x_0 = -c_k [k+1][p-1-k] E^{p-k-2} F^{p-1} x_0 \\
&= c_{k+1} E^{p-k-2} z_{p-1} = z_{k+1}
\end{aligned}$$

Hence $F(z_k) = F(z_{k+1})$, and we have that the set of elements $\{z_0, \dots, z_{p-1}\}$ is isomorphic to the basis of \mathcal{X}_p^- , and hence we have $Im \beta \simeq \mathcal{X}_p^-$.

Note that $Rank(\alpha) = Rank(\beta) = p$, and as $\bar{U}_q(\mathfrak{sl}_2)$ commutes with both α and β , we have proven that $Im(\alpha) \simeq Im(\beta) \simeq \mathcal{X}_p^-$.

From this we can state that the composition of any (non-identity containing) TL element with α or β is zero, as any TL element can be thought of as a map to \mathcal{X}_s^+ or \mathcal{P}_s^+ , but there are no non-zero homomorphisms between \mathcal{X}_p^- and these modules, hence the product must be zero.

5.3.3 Composition of α and β

What are $\beta(\alpha(x))$, $\alpha(\beta(x))$? Consider first $\beta(\alpha(x))$. If $x \in X_{p-1, 2p-1}$, then $\alpha(x) = e_x x_{2p-1}$ and $\beta(\alpha(x)) = e_x F^{p-1} x_0$. However for other elements it is not so straightforward. First we need to calculate $f_{\alpha(x)}$ where $F^{2p-m-1}(\alpha(x)) = f_{\alpha(x)} x_{2p-1}$.

From before, we have:

$$\begin{aligned}
F(\alpha(x)) &= e_x F E^{p-k-1} x_{2p-1} = e_x [k+1][2p-k-1] E^{p-k-2} x_{2p-1} \\
\text{Hence } F^j(\alpha(x)) &= e_x \frac{([k+j]!)([2p-k-1]!)}{([k]!)([2p-k-j-1]!)} E^{p-k-j-1} x_{2p-1} \\
F^{p-k-1}(\alpha(x)) &= e_x \frac{([p-1]!)([2p-k-1]!)}{([k]!)([p]!)} x_{2p-1} \\
\text{Therefore } f_{\alpha(x)} &= e_x \frac{([2p-k-1]!)}{([k]!)[p]}
\end{aligned}$$

This means:

$$\beta(\alpha(x)) = e_x \frac{([2p-k-1]!)}{([k]!)[p]} F^k x_0, \quad x \in X_{k, 2p-1}, \quad 0 \leq k \leq p-1$$

For $\alpha(\beta(x))$, if $x \in X_{p,2p-1}$, then $\beta(x) = f_x x_0$ and $\alpha(\beta(x)) = f_x E^{p-1} x_{2p-1}$. For the other elements, we have:

$$\begin{aligned} E(\beta(x)) &= f_x E F^{k-p} x_0 = f_x [2p-k][k] F^{k-p-1} x_0 \\ \text{Hence } E^j(\beta(x)) &= f_x \frac{([2p-k+j-1]!)([k]!)}{([2p-k-1]!)([k-j]!)} F^{k-p-j} x_0 \\ E^{k-p}(\beta(x)) &= f_x \frac{([p-1]!)([k]!)}{([2p-k-1]!)([p]!)} x_0 \\ \text{Therefore } e_{\beta(x)} &= f_x \frac{([k]!)}{([2p-k-1]!)[p]} \end{aligned}$$

This means:

$$\alpha(\beta(x)) = f_x \frac{([k]!)}{([2p-k-1]!)[p]} E^{2p-k-1} x_{2p-1}, \quad x \in X_{k,2p-1}, \quad p \leq k \leq 2p-1$$

Note that, given $x \in X_{k,2p-1}$, $\alpha(\beta(x)) \in X_{k,2p-1}$, $\beta(\alpha(x)) \in X_{k,2p-1}$, and $\alpha(\beta(x)) = 0$ for $0 \leq k \leq p-1$, $\beta(\alpha(x)) = 0$ for $p \leq k \leq 2p-1$.

Combining these further, we find that:

$$e_{\beta(\alpha(x))} = e_x \frac{([2p-k-1]!)([k+p]!)}{([k]!)([p-k-1]!)[p]^2}, \quad 0 \leq k \leq p-1$$

Note that as $[p+i] = -[i]$, we can simplify this to get:

$$\begin{aligned} e_{\beta(\alpha(x))} &= e_x (-1)^{p-1} ([p-1]!)^2, \quad 0 \leq k \leq p-1 \\ \alpha(\beta(\alpha(x))) &= e_x (-1)^{p-1} ([p-1]!)^2 E^{p-k-1} x_{2p-1} \end{aligned}$$

Similarly, we have:

$$f_{\alpha(\beta(x))} = f_x \frac{([k]!)([3p-k-1]!)}{([2p-k-1]!)([k-p]!)[p]^2}, \quad p \leq k \leq 2p-1$$

Which simplifies to give:

$$\begin{aligned} f_{\alpha(\beta(x))} &= f_x (-1)^{p-1} ([p-1]!)^2 \\ \beta(\alpha(\beta(x))) &= f_x (-1)^{p-1} ([p-1]!)^2 F^{k-p} x_0 \end{aligned}$$

Let $\gamma = (-1)^{p-1} ([p-1]!)^2$. Then we have:

$$\begin{aligned} \alpha\beta\alpha &= \gamma\alpha & \beta\alpha\beta &= \gamma\beta \\ \alpha\beta\alpha\beta &= \gamma\alpha\beta & \beta\alpha\beta\alpha &= \gamma\beta\alpha \\ \left(\frac{\alpha\beta}{\gamma}\right)^2 &= \left(\frac{\alpha\beta}{\gamma}\right) & \left(\frac{\beta\alpha}{\gamma}\right)^2 &= \left(\frac{\beta\alpha}{\gamma}\right) \end{aligned}$$

From previously in section 5.3.2, we know that α and β give the image of \mathcal{P}_p^- . Hence, the two maps $\left(\frac{\alpha\beta}{\gamma}\right)$ and $\left(\frac{\beta\alpha}{\gamma}\right)$ are the projections onto the image of the two copies of \mathcal{P}_p^- in $X^{\otimes(2p-1)}$. It follows that α and β are then the maps between the two copies of this module.

5.3.4 Proof that $\alpha_i \alpha_j = \beta_i \beta_j = 0$ if $|i - j| < p$

We prove this by considering four cases; $\alpha_{1+k} \alpha_1$, $\alpha_1 \alpha_{1+k}$, $\beta_{1+k} \beta_1$, $\beta_1 \beta_{1+k}$.

Before we proceed we note equation A.9:

$$\Delta E^n = \sum_{i=0}^n \lambda_{i,n} E^i \otimes K^i E^{n-i}$$

where $\lambda_{0,n} = \lambda_{n,n} = 1$, $\lambda_{i,n} = \lambda_{i-1,n-1} + q^{-2i} \lambda_{i,n-1}$.

For $\alpha_{1+k} \alpha_1$, let $E^j x = e_x x_{0,k}$, $E^l y = e_y x_{0,2p-1-k}$, $E^m z = e_z x_{0,k}$, then:

$$\begin{aligned} E^{j+l}(x \otimes y) &= \lambda_{j,j+l}(E^j x) \otimes (K^j E^l y) = \lambda_{j,j+l} e_x e_y q^{j(2p-1-k)} x_{0,2p-1} \\ \alpha_1(x \otimes y \otimes z) &= \lambda_{j,j+l} e_x e_y q^{-j(k+1)} (E^{p-j-l-1} x_{2p-1,2p-1}) \otimes z \\ &= \sum_{i=0}^{p-j-l-1} \lambda_{j,j+l} e_x e_y q^{-j(k+1)} \lambda_{i,p-j-l-1} \times \\ &\quad \times (E^i x_{k,k}) \otimes (K^i E^{p-j-l-1-i} x_{2p-1-k,2p-1-k}) \otimes z \end{aligned}$$

To apply α_{1+k} to this, we need E^{2p-1-k} acting on $x_{2p-1-k,2p-1-k}$ to get to $x_{0,2p-1-k}$, however, since $E^p = 0$, this implies that $\alpha_{1+k}(\alpha_1(x \otimes y \otimes z))$ will be zero if $2p-1-k \geq p$, which reduces to $k \leq p-1$.

Consider now $\alpha_1(\alpha_{1+k}(x \otimes y \otimes z))$. We have:

$$\begin{aligned} E^{l+m}(y \otimes z) &= \lambda_{l,l+m}(E^l y) \otimes (K^l E^m z) = e_y e_z \lambda_{l,l+m} q^{lk} x_{0,2p-1} \\ \alpha_{1+k}(x \otimes y \otimes z) &= e_y e_z \lambda_{l,l+m} q^{lk} x \otimes (E^{p-l-m-1} x_{2p-1,2p-1}) \\ &= \sum_{i=0}^{p-l-m-1} e_y e_z q^{lk} \lambda_{l,l+m} \lambda_{i,p-l-m-1} \times \\ &\quad \times x \otimes (E^i x_{2p-1-k,2p-1-k}) \otimes (K^i E^{p-l-m-1-i} x_{k,k}) \end{aligned}$$

To apply α_1 to this, we again need E^{2p-1-k} acting on $x_{2p-1-k,2p-1-k}$ to get $x_{0,2p-1-k}$. Hence this will be zero if $2p-1-k \geq p$, which reduces to $k \leq p-1$.

For β , we first note equation A.10:

$$\Delta F^n = \sum_{i=0}^n \lambda_{i,n} K^{-i} F^{n-i} \otimes F^i$$

where $\lambda_{0,n} = \lambda_{n,n} = 1$, $\lambda_{i,n+1} = \lambda_{i-1,n} + q^{-2i} \lambda_{i,n}$.

Let $F^j x = f_x x_{k,k}$, $F^l y = f_y x_{2p-1-k, 2p-1-k}$, $F^m z = f_z x_{k,k}$.

For $\beta_{1+k}\beta_1$ we have:

$$\begin{aligned} F^{j+l}(x \otimes y) &= \lambda_{l,j+l}(K^{-l}F^j x) \otimes (F^l y) = f_x f_y \lambda_{l,j+l} q^{lk} x_{2p-1, 2p-1} \\ \beta_1(x \otimes y \otimes z) &= f_x f_y \lambda_{l,j+l} q^{lk} (F^{p-j-l-1} x_{0, 2p-1}) \otimes z \\ &= \sum_{i=0}^{p-j-l-1} f_x f_y \lambda_{l,j+l} q^{lk} \lambda_{i,p-j-l-1} (K^{-i} F^{p-j-l-1-i} x_{0,k}) \otimes (F^i x_{0, 2p-1-k}) \otimes z \end{aligned}$$

To apply β_{k+1} to this, we need F^{2p-1-k} to act on $x_{0, 2p-1-k}$. However, since $F^p = 0$, this will be zero if $2p-1-k > p-1$, which reduces to $k < p$.

For $\beta_1\beta_{k+1}$ we have:

$$\begin{aligned} F^{l+m}(y \otimes z) &= \lambda_{m,l+m}(K^{-m}F^l y) \otimes (F^m z) = f_y f_z \lambda_{m,l+m} q^{m(2p-1-k)} x_{2p-1, 2p-1} \\ \beta_{k+1}(x \otimes y \otimes z) &= f_y f_z \lambda_{m,l+m} q^{-m(k+1)} x \otimes (F^{p-l-m-1} x_{0, 2p-1}) \\ &= \sum_{i=0}^{p-l-m-1} f_y f_z \lambda_{m,l+m} q^{-m(k+1)} \lambda_{i,p-l-m-1} \times \\ &\quad \times x \otimes (K^{-i} F^{p-l-m-1-i} x_{0, 2p-1-k}) \otimes (F^i x_{0,k}) \end{aligned}$$

To apply β_1 to this, we again need F^{2p-1-k} acting on $x_{0, 2p-1-k}$, which will be zero if $2p-1-k > p-1$, which reduces to $k < p$.

Hence we have shown that $\alpha_1\alpha_{1+k} = \alpha_{1+k}\alpha_1 = \beta_1\beta_{1+k} = \beta_{1+k}\beta_1 = 0$ if $k < p$, and so we have proven:

Proposition 5.1. *The $\bar{U}_q(\mathfrak{sl}_2)$ generators satisfy $\alpha_i\alpha_j = \beta_i\beta_j = 0$ if $|i-j| < p$*

Note that in the proof, this only depended on the amount of overlap, i.e. the value of k in $\alpha_1\alpha_{1+k}$. Hence this condition holds, even if there is another element acting between the non-overlap parts.

For example, $\alpha_i\beta_{i+k}\alpha_i = 0$ if $k > p-1$.

In general any diagram with α or β acting twice on p or more strings is zero.

5.3.5 Proof that $\alpha_i\alpha_{i+p} = \alpha_{i+p}\alpha_i$ and $\beta_i\beta_{i+p} = \beta_{i+p}\beta_i$

Using the same notation as the previous section, we have $\alpha_1(x \otimes y \otimes z) =$

$$\sum_{i=0}^{p-j-l-1} \lambda_{j,i+l} e_x e_y q^{-j(p+1)} \lambda_{i,p-j-l-1} (E^i x_{p,p}) \otimes (K^i E^{p-j-l-i-1} x_{p-1,p-1}) \otimes z$$

Then we have $E^{j+l+i+m}((K^i E^{p-j-l-i-1} x_{p-1,p-1}) \otimes z) =$

$$\begin{aligned} & \lambda_{j+l+i,j+l+i+m}(E^{j+l+i} K^i E^{p-j-l-i-1} x_{p-1,p-1}) \otimes (K^{j+l+i} E^m z) \\ &= e_z \lambda_{j+l+i,j+l+i+m} q^{(2i(p-j-l-i-1)+i(1-p))} (E^{p-1} x_{p-1,p-1}) \otimes (K^{j+l+i} x_{0,p}) \\ &= \lambda_{j+l+i,j+l+i+m} e_z q^{2i(p-j-l-i-1)+i(1-p)+p(j+l+i)} ([p-1]!) x_{0,2p-1} \end{aligned}$$

As $E^p = 0$, we only need to consider the terms where $j+l+i+m \leq p-1$, which gives $i \leq p-j-l-m-1$. Hence we have $\alpha_{1+p}(\alpha_1(x \otimes y \otimes z)) =$

$$\begin{aligned} & \sum_{i=0}^{p-j-l-m-1} \lambda_{j,j+l} e_x e_y q^{-j(p+1)} \lambda_{i,p-j-l-1} \lambda_{j+l+i,j+l+i+m} e_z q^{2i(p-j-l-i-1)+i(1-p)+p(j+l+i)} \times \\ & \times ([p-1]!) (E^i x_{p,p}) \otimes (E^{p-1-j-l-i-m} x_{2p-1,2p-1}) \\ &= \sum_{i=0}^{p-j-l-m-1} \left(\sum_{n=0}^{p-1-j-l-i-m} e_x e_y e_z \lambda_{j,j+l} \lambda_{i,p-j-l-1} \lambda_{j+l+i,j+l+i+m} q^{(2ip-i-j-2ij-2il-2i^2+pl)} \times \right. \\ & \left. \times \lambda_{n,p-1-j-l-i-m} ([p-1]!) (E^i x_{p,p}) \otimes (E^n x_{p-1,p-1}) \otimes (K^n E^{p-1-j-l-i-m-n} x_{p,p}) \right) \end{aligned}$$

Next we have $\alpha_{1+p}(x \otimes y \otimes z) =$

$$\sum_{r=0}^{p-l-m-1} e_y e_z q^{lp} \lambda_{l,l+m} \lambda_{r,p-l-m-1} x \otimes (E^r x_{p-1,p-1}) \otimes (K^r E^{p-l-m-r-1} x_{p,p})$$

Then we have:

$$\begin{aligned} E^{j+p-r-1}(x \otimes (E^r x_{p-1,p-1})) &= \lambda_{j,j+p-r-1} (E^j x) \otimes (K^j E^{p-1} x_{p-1,p-1}) \\ &= e_x \lambda_{j,j+p-r-1} q^{j(p-1)} ([p-1]!) x_{0,2p-1} \end{aligned}$$

Again as $E^p = 0$, we only need consider the terms where $j+p-r-1 \leq p-1$, which gives $r \geq j$. Hence we have $\alpha_1(\alpha_{1+p}(x \otimes y \otimes z)) =$

$$\begin{aligned} & \sum_{r=j}^{p-l-m-1} e_y e_z q^{lp} \lambda_{l,l+m} \lambda_{r,p-l-m-1} e_x \lambda_{j,j+p-r-1} q^{j(p-1)} ([p-1]!) \times \\ & \times (E^{r-j} x_{2p-1,2p-1}) \otimes (K^r E^{p-l-m-r-1} x_{p,p}) \\ &= \sum_{r=j}^{p-l-m-1} \left(\sum_{s=0}^{r-j} e_x e_y e_z \lambda_{l,l+m} \lambda_{r,p-l-m-1} \lambda_{j,j+p-r-1} q^{lp+j(p-1)} ([p-1]!) \times \right. \\ & \left. \times \lambda_{s,r-j} (E^s x_{p,p}) \otimes (K^s E^{r-j-s} x_{p-1,p-1}) \otimes (K^r E^{p-l-m-r-1} x_{p,p}) \right) \end{aligned}$$

Let $t = r - j$, then this becomes:

$$\begin{aligned} & \sum_{t=0}^{p-l-m-j-1} \left(\sum_{s=0}^t e_x e_y e_z \lambda_{l,l+m} \lambda_{t+j,p-l-m-1} \lambda_{j,p-t-1} q^{lp+j(p-1)} ([p-1]!) \times \right. \\ & \left. \times \lambda_{s,t} (E^s x_{p,p}) \otimes (K^s E^{t-s} x_{p-1,p-1}) \otimes (K^{t+j} E^{p-l-m-j-t-1} x_{p,p}) \right) \end{aligned}$$

Using the summation identity $\sum_{u=0}^w \sum_{v=0}^u x_{u,v} = \sum_{v=0}^w \sum_{u=v}^w x_{u,v}$, this becomes:

$$\sum_{s=0}^{p-l-m-j-1} \left(\sum_{t=s}^{p-l-m-j-1} e_x e_y e_z \lambda_{l,l+m} \lambda_{t+j,p-l-m-1} \lambda_{j,p-t-1} q^{lp+j(p-1)} ([p-1]!) \times \right. \\ \left. \times \lambda_{s,t}(E^s x_{p,p}) \otimes (K^s E^{t-s} x_{p-1,p-1}) \otimes (K^{t+j} E^{p-l-m-j-t-1} x_{p,p}) \right)$$

Let $n = t - s$, then we have:

$$\sum_{s=0}^{p-l-m-j-1} \left(\sum_{n=0}^{p-l-m-j-1-s} e_x e_y e_z \lambda_{l,l+m} \lambda_{n+s+j,p-l-m-1} \lambda_{j,p-n-s-1} q^{lp+j(p-1)} ([p-1]!) \times \right. \\ \left. \times \lambda_{s,n+s}(E^s x_{p,p}) \otimes (K^s E^n x_{p-1,p-1}) \otimes (K^{n+s+j} E^{p-l-m-j-n-s-1} x_{p,p}) \right)$$

Letting $s = i$ we have:

$$\sum_{i=0}^{p-l-m-j-1} \left(\sum_{n=0}^{p-l-m-j-1-i} e_x e_y e_z \lambda_{l,l+m} \lambda_{n+i+j,p-l-m-1} \lambda_{j,p-n-i-1} q^{lp+j(p-1)} ([p-1]!) \times \right. \\ \left. \times \lambda_{i,n+i}(E^i x_{p,p}) \otimes (K^i E^n x_{p-1,p-1}) \otimes (K^{n+i+j} E^{p-l-m-j-n-i-1} x_{p,p}) \right) \\ = \sum_{i=0}^{p-l-m-j-1} \left(\sum_{n=0}^{p-l-m-j-1-i} e_x e_y e_z \lambda_{l,l+m} \lambda_{n+i+j,p-l-m-1} \lambda_{j,p-n-i-1} q^{lp+j(p-1)} \times \right. \\ \left. \times q^{(2in-i(p-1))} q^{(2(i+j)(p-l-m-j-n-i-1)-p(i+j))} ([p-1]!) \lambda_{i,n+i} \times \right. \\ \left. \times (E^i x_{p,p}) \otimes (E^n x_{p-1,p-1}) \otimes (K^n E^{p-l-m-j-n-i-1} x_{p,p}) \right) \\ = \sum_{i=0}^{p-l-m-j-1} \left(\sum_{n=0}^{p-l-m-j-1-i} e_x e_y e_z \lambda_{l,l+m} \lambda_{n+i+j,p-l-m-1} \lambda_{j,p-n-i-1} ([p-1]!) \times \right. \\ \left. \times q^{(lp-i-2i^2-3j-4ij-2j^2-2il-2jl-2im-2jm-2jn+2jp)} \lambda_{i,n+i} \times \right. \\ \left. \times (E^i x_{p,p}) \otimes (E^n x_{p-1,p-1}) \otimes (K^n E^{p-l-m-j-n-i-1} x_{p,p}) \right)$$

This is now the same summation as $\alpha_{1+p}\alpha_1$, hence we want to show that the coefficients are equal for both. We then want to show:

$$q^{(2ip-j-2ij-2il-2i^2+pl)} \lambda_{j,j+l} \lambda_{i,p-j-l-1} \lambda_{j+l+i,j+l+i+m} \lambda_{n,p-1-j-l-i-m} \\ = q^{(jp-2il-2im-4ij-2i^2-i-2jl-2jm-2j^2-2jn-2j)} \lambda_{l,l+m} \lambda_{n+i+j,p-l-m-1} \lambda_{j,p-n-i-1} \lambda_{i,n+i}$$

for $0 \leq i \leq p-l-m-j-1$ and $0 \leq n \leq p-l-m-j-1-i$. For this we need to use the following from Appendix A:

$$\lambda_{x,y} = q^{(x^2-xy)} \frac{([y]!)}{([x]!)([y-x]!)}$$

The coefficients then become:

$$\begin{aligned}
& q^{(2ip-i-j-2ij-2il-2i^2+pl)} q^{(j^2-j(j+l))} q^{(i^2-i(p-j-l-1))} \times \\
& \times q^{((j+l+i)^2-(j+l+i)(j+l+i+m))} q^{(n^2-n(p-1-j-l-i-m))} \frac{([j+l]!)}{([j]!)([l]!)} \times \\
& \times \frac{([p-j-l-1]!)([j+l+i+m]!)([p-1-j-l-i-m]!)}{([i]!)([p-j-l-i-1]!)([j+l+i]!)([m]!)([n]!)([p-1-j-l-i-m-n]!)} \\
& = q^{(lp-i-2i^2-3j-4ij-2j^2-2il-2jl-2im-2jm-2jn+2jp)} \times \\
& \times q^{(l^2-l(l+m))} q^{((n+i+j)^2-(n+i+j)(p-l-m-1))} q^{(j^2-j(p-n-i-1))} q^{(i^2-i(n+i))} \frac{([l+m]!)}{([l]!)([m]!)} \times \\
& \times \frac{([p-l-m-1]!)([p-i-1]!)([n+i]!)}{([n+i+j]!)([p-l-m-1-n-i-j]!)([j]!)([p-n-i-1-j]!)([i]!)([n]!)}
\end{aligned}$$

This simplifies to give:

$$\begin{aligned}
& q^{(lp-i^2-j-ij-il-jl-im-jm-lm+n+in+jn+ln+mn+n^2+ip-np)} \times \\
& \times \frac{([j+l]!)([p-j-l-1]!)([j+l+i+m]!)([p-1-j-l-i-m]!)}{([p-j-l-i-1]!)([j+l+i]!)} \\
& = q^{(lp-i^2-j-ij-il-jl-im-jm-lm+n+in+jn+ln+mn+n^2-ip-np)} \times \\
& \times \frac{([l+m]!)([p-l-m-1]!)([p-n-i-1]!)([n+i]!)}{([n+i+j]!)([p-n-i-1-j]!)}
\end{aligned}$$

Simplifying further, we get:

$$\begin{aligned}
& \frac{([j+l]!)([p-j-l-1]!)([j+l+i+m]!)([p-1-j-l-i-m]!)}{([p-j-l-i-1]!)([j+l+i]!)} \\
& = q^{(-2ip)} \frac{([l+m]!)([p-l-m-1]!)([p-n-i-1]!)([n+i]!)}{([n+i+j]!)([p-n-i-1-j]!)}
\end{aligned}$$

As $[p-x] = [x]$, we have $([x]!)([p-1-x]!) = ([p-1]!)$. Therefore it reduces to:

$$([p-1]!) = q^{-2ip}([p-1]!)$$

Hence the coefficients are equal, and so we have shown that $\alpha_1\alpha_{1+p} = \alpha_{1+p}\alpha_1$.

For the β case, again using the notation from the previous section, we have:

$$\beta_1(x \otimes y \otimes z) = \sum_{i=0}^{p-j-l-1} f_x f_y \lambda_{l,j+l} q^{lp} \lambda_{i,p-j-l-1} (K^{-i} F^{p-j-l-1-i} x_{0,p}) \otimes (F^i x_{0,p-1}) \otimes z$$

Then we have:

$$\begin{aligned}
F^{p+m-i-1}((F^i x_{0,p-1}) \otimes z) & = \lambda_{m,p+m-i-1} (K^{-m} F^{p-1} x_{0,p-1}) \otimes (F^m z) \\
& = f_z \lambda_{m,p+m-i-1} q^{m(p-1)} ([p-1]!) x_{2p-1,2p-1}
\end{aligned}$$

As $F^p = 0$, we only need to consider the terms where $p + m - i - 1 \leq p - 1$, which gives $i \geq m$. Hence we have $\beta_{1+p}(\beta_1(x \otimes y \otimes z)) =$

$$\begin{aligned} & \sum_{i=m}^{p-j-l-1} f_x f_y f_z \lambda_{l,j+l} \lambda_{i,p-j-l-1} \lambda_{m,p+m-i-1} q^{lp+m(p-1)} ([p-1]!) \times \\ & \quad \times (K^{-i} F^{p-j-l-1-i} x_{0,p}) \otimes (F^{i-m} x_{0,2p-1}) \\ & = \sum_{i=m}^{p-j-l-1} \left(\sum_{n=0}^{i-m} f_x f_y f_z \lambda_{l,j+l} \lambda_{i,p-j-l-1} \lambda_{m,p+m-i-1} \lambda_{n,i-m} q^{lp+m(p-1)} ([p-1]!) \times \right. \\ & \quad \left. \times (K^{-i} F^{p-j-l-1-i} x_{0,p}) \otimes (K^{-n} F^{i-m-n} x_{0,p-1}) \otimes (F^n x_{0,p}) \right) \end{aligned}$$

Let $t = i - m$. This becomes:

$$\begin{aligned} & \sum_{t=0}^{p-j-l-m-1} \left(\sum_{n=0}^t f_x f_y f_z \lambda_{l,j+l} \lambda_{t+m,p-j-l-1} \lambda_{m,p-t-1} \lambda_{n,t} q^{lp+m(p-1)} ([p-1]!) \times \right. \\ & \quad \left. \times (K^{-t-m} F^{p-j-l-1-t-m} x_{0,p}) \otimes (K^{-n} F^{t-n} x_{0,p-1}) \otimes (F^n x_{0,p}) \right) \end{aligned}$$

Using the summation identity $\sum_{u=0}^w \sum_{v=0}^u x_{u,v} = \sum_{v=0}^w \sum_{u=v}^w x_{u,v}$, this becomes:

$$\begin{aligned} & \sum_{n=0}^{p-j-l-m-1} \left(\sum_{t=n}^{p-j-l-m-1} f_x f_y f_z \lambda_{l,j+l} \lambda_{t+m,p-j-l-1} \lambda_{m,p-t-1} \lambda_{n,t} q^{lp+m(p-1)} ([p-1]!) \times \right. \\ & \quad \left. \times (K^{-t-m} F^{p-j-l-1-t-m} x_{0,p}) \otimes (K^{-n} F^{t-n} x_{0,p-1}) \otimes (F^n x_{0,p}) \right) \end{aligned}$$

Let $s = t - n$, then we have:

$$\begin{aligned} & \sum_{n=0}^{p-j-l-m-1} \left(\sum_{s=0}^{p-j-l-m-1-n} f_x f_y f_z \lambda_{l,j+l} \lambda_{s+n+m,p-j-l-1} \lambda_{m,p-s-n-1} \lambda_{n,s+n} q^{lp+m(p-1)} \times \right. \\ & \quad \left. \times ([p-1]!) (K^{-s-n-m} F^{p-j-l-1-s-n-m} x_{0,p}) \otimes (K^{-n} F^s x_{0,p-1}) \otimes (F^n x_{0,p}) \right) \end{aligned}$$

Replacing n with r this becomes:

$$\begin{aligned} & \sum_{r=0}^{p-j-l-m-1} \left(\sum_{s=0}^{p-j-l-m-1-r} f_x f_y f_z \lambda_{l,j+l} \lambda_{s+r+m,p-j-l-1} \lambda_{m,p-s-r-1} \lambda_{r,s+r} q^{lp+m(p-1)} \times \right. \\ & \quad \left. \times ([p-1]!) (K^{-s-r-m} F^{p-j-l-1-s-r-m} x_{0,p}) \otimes (K^{-r} F^s x_{0,p-1}) \otimes (F^r x_{0,p}) \right) \end{aligned}$$

Next we have $\beta_{1+p}(x \otimes y \otimes z) =$

$$\sum_{r=0}^{p-l-m-1} f_y f_z \lambda_{m,l+m} q^{-m(p+1)} \lambda_{r,p-l-m-1} x \otimes (K^{-r} F^{p-l-m-1-r} x_{0,p-1}) \otimes (F^r x_{0,p})$$

Then we have $F^{j+l+m+r}(x \otimes (K^{-r} F^{p-l-m-1-r} x_{0,p-1})) =$

$$\begin{aligned} & \lambda_{l+m+r,j+l+m+r} (K^{-l-m-r} F^j x) \otimes (F^{l+m+r} K^{-r} F^{p-l-m-1-r} x_{0,p-1}) \\ & = f_x \lambda_{l+m+r,j+l+m+r} q^{p(l+m+r)+2r(p-l-m-1-r)-r(p-1)} ([p-1]!) x_{2p-1,2p-1} \end{aligned}$$

Again as $F^p = 0$, we only need to consider the terms where $j + l + m + r \leq p - 1$, which gives $r \leq p - j - l - m - 1$. Hence we have $\beta_1(\beta_{1+p}(x \otimes y \otimes z)) =$

$$\begin{aligned} & \sum_{r=0}^{p-j-l-m-1} f_x f_y f_z \lambda_{m,l+m} \lambda_{r,p-l-m-1} q^{\binom{p(l+m+r)+2r(p-l-m-1-r)-m(p+1)-r(p-1)}{}} \times \\ & \quad \times \lambda_{l+m+r,j+l+m+r}([p-1]!)(F^{p-j-l-m-r-1}x_{0,2p-1}) \otimes (F^r x_{0,p}) \\ = & \sum_{r=0}^{p-j-l-m-1} \left(\sum_{s=0}^{p-j-l-m-r-1} f_x f_y f_z \lambda_{m,l+m} \lambda_{r,p-l-m-1} \lambda_{l+m+r,j+l+m+r} \lambda_{s,p-j-l-m-r-1} \times \right. \\ & \quad \times q^{\binom{p(l+m+r)+2r(p-l-m-1-r)-m(p+1)-r(p-1)}{}} ([p-1]!) \times \\ & \quad \left. \times (K^{-s} F^{p-j-l-m-r-1-s} x_{0,p}) \otimes (F^s x_{0,p-1}) \otimes (F^r x_{0,p}) \right) \end{aligned}$$

This is the same summation as $\beta_{1+p}\beta_1$. Hence we want to show that the coefficients are equal for both. We then want to show:

$$\begin{aligned} & q^{\binom{l(p+m(p-1)+2rs-r(p-1)+2(s+r+m)(p-j-l-m-s-r-1)-p(s+r+m)}{}} \times \\ & \quad \times \lambda_{l,j+l} \lambda_{s+r+m,p-j-l-1} \lambda_{m,p-s-r-1} \lambda_{r,s+r} \\ = & q^{\binom{p(l+m+r)+2r(p-l-m-1-r)-m(p+1)-r(p-1)+2s(p-j-l-m-r-s-1)-sp}{}} \times \\ & \quad \times \lambda_{m,l+m} \lambda_{r,p-l-m-1} \lambda_{l+m+r,j+l+m+r} \lambda_{s,p-j-l-m-r-1} \end{aligned}$$

Using $\lambda_{x,y} = q^{\binom{x^2-xy}{}} \frac{([y]!)}{([x]!)([y-x]!)}$, this becomes:

$$\begin{aligned} & q^{\binom{l(p+m(p-1)+2rs-r(p-1)+2(s+r-m)(p-j-l-m-s-r-1)-p(s+r-m)}{}} \times \\ & \quad \times q^{\binom{l^2-l(j+l)+(s+r+m)^2-(s+r+m)(p-j-l-1)+m^2-m(p-s-r-1)+r^2-r(s+r)}{}} \frac{([j+l]!)}{([l]!)([j]!)} \times \\ & \quad \times \frac{([p-j-l-1]!)([p-s-r-1]!)([s+r]!)}{([s+r+m]!)([p-j-l-m-r-s-1]!)([m]!)([p-m-r-s-1]!)([r]!)([s]!)} \\ = & q^{\binom{m^2-m(l+m)+r^2-r(p-l-m-1)+(l+m+r)^2-(l+m+r)(j+l+m+r)+s^2-s(p-j-l-m-r-1)}{}} \times \\ & \quad \times q^{\binom{p(l+m+r)+2r(p-l-m-1-r)-m(p+1)-r(p-1)+2s(p-j-l-m-r-s-1)-sp}{}} \frac{([l+m]!)}{([m]!)([l]!)} \times \\ & \quad \times \frac{([p-l-m-1]!)([j+l+m+r]!)([p-j-l-m-r-1]!)}{([r]!)([p-l-m-r-1]!)([l+m+r]!)([j]!)([s]!)([p-j-l-m-r-s-1]!)} \end{aligned}$$

Simplifying this, we get:

$$\begin{aligned} & q^{(-2rp)} \frac{([j+l]!)([p-j-l-1]!)([p-s-r-1]!)([s+r]!)}{([s+r+m]!)([p-m-r-s-1]!)} \\ = & \frac{([l+m]!)([p-l-m-1]!)([j+l+m+r]!)([p-j-l-m-r-1]!)}{([p-l-m-r-1]!)([l+m+r]!)} \end{aligned}$$

Again using $([x]!)([p-1-x]!) = ([p-1]!)$, this becomes:

$$q^{(-2rp)}([p-1]!) = ([p-1]!)$$

Hence the coefficients are equal, and so we have shown that $\beta_1\beta_{1+p} = \beta_{1+p}\beta_1$.

Hence we have proven:

Proposition 5.2. *The $\bar{U}_q(\mathfrak{sl}_2)$ generators, α and β , satisfy:*

$$\alpha_i\alpha_{i+p} = \alpha_{i+p}\alpha_i$$

$$\beta_i\beta_{i+p} = \beta_{i+p}\beta_i$$

for all i .

5.3.6 Proof that $\alpha\beta + \beta\alpha = \gamma\mathfrak{f}_{2p-1}$

We want to show that $\alpha\beta + \beta\alpha = \gamma\mathfrak{f}_{2p-1}$, where \mathfrak{f}_{2p-1} is the $(2p-1)$ th Jones-Wenzl projection.

From section 5.3.3 we have:

$$\begin{aligned}\beta(\alpha(x)) &= e_x \frac{([2p-k-1]!)}{([k]!)[p]} F^k x_0, \quad x \in X_{k,2p-1}, \quad 0 \leq k \leq p-1 \\ \alpha(\beta(x)) &= f_x \frac{([k]!)}{([2p-k-1]!)[p]} E^{2p-k-1} x_{2p-1}, \quad x \in X_{k,2p-1}, \quad p \leq k \leq 2p-1\end{aligned}$$

From appendix B we have:

$$\begin{aligned}\mathfrak{f}_{2p-1}(\rho_{i_1, \dots, i_n, 2p-1}) &= q \frac{\binom{n(2p-1) - \frac{1}{2}(n^2-n) - (\sum_{j=1}^n i_j)}{([2p-1-n]!)} F^n x_{0,2p-1}}{([2p-1]!)} \\ &= (-1)^{p-1} q \frac{\binom{n(2p-1) - \frac{1}{2}(n^2-n) - (\sum_{j=1}^n i_j)}{([2p-1-n]!)} F^n x_{0,2p-1}}{([p-1]!)^2 [p]} \\ &= \gamma^{-1} q \frac{\binom{n(2p-1) - \frac{1}{2}(n^2-n) - (\sum_{j=1}^n i_j)}{([2p-1-n]!)} F^n x_{0,2p-1}}{[p]}\end{aligned}$$

For $0 \leq n \leq p-1$, we have:

$$\begin{aligned}\beta\alpha(\rho_{i_1, \dots, i_n, 2p-1}) &= q \frac{\binom{n(2p-1) - \frac{1}{2}(n^2-n) - (\sum_{j=1}^n i_j)}{([n]!)([2p-n-1]!)} F^n x_{0,2p-1}}{([n]!)[p]} \\ &= q \frac{\binom{n(2p-1) - \frac{1}{2}(n^2-n) - (\sum_{j=1}^n i_j)}{([2p-n-1]!)} F^n x_{0,2p-1}}{[p]} \\ &= \gamma\mathfrak{f}_{2p-1}(\rho_{i_1, \dots, i_n, 2p-1}) \quad 0 \leq n \leq p-1\end{aligned}$$

For $p \leq n \leq 2p-1$ we have:

$$\begin{aligned}\alpha\beta(\rho_{i_1, \dots, i_n, 2p-1}) &= q \frac{\binom{n(2p-1) - \frac{1}{2}(n^2-n) - (\sum_{j=1}^n i_j)}{([2p-1-n]!)([n]!)} E^{2p-n-1} x_{2p-1,2p-1}}{([2p-n-1]!)[p]} \\ &= q \frac{\binom{n(2p-1) - \frac{1}{2}(n^2-n) - (\sum_{j=1}^n i_j)}{[n]!} E^{2p-n-1} x_{2p-1,2p-1}}{[p]}\end{aligned}$$

We need to rewrite $E^{2p-n-1}x_{2p-1,2p-1}$ in terms of F . Using equations A.15 and A.17 we have:

$$([n!])E^{2p-n-1}x_{2p-1,2p-1} = ([2p-n-1!])F^n x_{0,2p-1}$$

Hence we have that:

$$\alpha\beta(\rho_{i_1, \dots, i_n, 2p-1}) = \gamma \mathfrak{f}_{2p-1}(\rho_{i_1, \dots, i_n, 2p-1}), \quad p \leq n \leq 2p-1$$

Combining the two results we have:

$$(\alpha\beta + \beta\alpha)(\rho_{i_1, \dots, i_n, 2p-1}) = \gamma \mathfrak{f}_{2p-1}(\rho_{i_1, \dots, i_n, 2p-1}), \quad 0 \leq n \leq 2p-1$$

$$\text{Therefore } \alpha\beta + \beta\alpha = \gamma \mathfrak{f}_{2p-1}$$

Note that although technically we should be taking $E^{p+i}x_{2p-1,2p-1} = F^{p+i}x_{0,2p-1} = 0$, here we are only using them to represent elements of $X_{p-i-1,2p-1}$, $X_{p+i,2p-1}$ respectively.

5.4 Relations between α , β and the Temperley-Lieb algebra.

We saw at the end of section 5.3.2 that applying a cup or cap to α and β gives zero and so that given any element x of TL_{2p-1} that doesn't contain the identity, $x\alpha = \alpha x = x\beta = \beta x = 0$. However, for a cup or cap such that only one string acts on α or β , the result can be non-zero. We prove in this section some more general relations between the generators and the Temperley-Lieb algebra, as well as a result that generalizes a large number of relations.

5.4.1 Proof of capping and cupping relations.

We want to prove the capping and cupping relations given in equations 5.15 - 5.18. We shall see that we only need to prove the capping relations, and can then use them to diagrammatically prove the cupping relations, as well as rotational invariance of α and β , and that their partial traces are zero.

The capping relations are:

$$\begin{array}{c} \text{---} \\ | \\ \boxed{\alpha} \\ | \\ \text{---} \end{array} \begin{array}{c} \text{---} \\ \cup \\ \text{---} \end{array} = \begin{array}{c} \text{---} \\ \cup \\ \text{---} \\ | \\ \boxed{\alpha} \\ | \\ \text{---} \end{array}, \quad \begin{array}{c} \text{---} \\ | \\ \boxed{\beta} \\ | \\ \text{---} \end{array} \begin{array}{c} \text{---} \\ \cup \\ \text{---} \end{array} = \begin{array}{c} \text{---} \\ \cup \\ \text{---} \\ | \\ \boxed{\beta} \\ | \\ \text{---} \end{array}$$

We start our proof with α .

Explicitly, we want to show that $\alpha_1(\cap_{2p}(\rho_{i_1, \dots, i_n, 2p-2})) = \alpha_2(\cap_1(\rho_{i_1, \dots, i_n, 2p-2}))$.

Given $\cap(\nu) = q^{-1}\nu_{10} - \nu_{01}$, we can rewrite this as:

$$\begin{aligned} & q^{-1}\alpha(\rho_{i_1, \dots, i_n, 2p-2} \otimes \nu_1) \otimes \nu_0 - \alpha(\rho_{i_1, \dots, i_n, 2p-2} \otimes \nu_0) \otimes \nu_1 \\ &= q^{-1}\nu_1 \otimes \alpha(\nu_0 \otimes \rho_{i_1, \dots, i_n, 2p-2}) - \nu_0 \otimes \alpha(\nu_1 \otimes \rho_{i_1, \dots, i_n, 2p-2}) \end{aligned}$$

To simplify this, we need equation A.9:

$$(\Delta(E))^n = \sum_{i=0}^n \lambda_{i,n} E^i \otimes K^i E^{n-i}$$

where $\lambda_{i,n} = q^{(i^2-in)} \frac{([n]!)}{([i]!)[n-i]!}$.

Given $E^n \rho_{i_1, \dots, i_n, 2p-2} = e_n x_{0, 2p-2}$, then we only need to consider the relevant part of $(\Delta(E))^n$, where one side of the coproduct acts on $\rho_{i_1, \dots, i_n, 2p-2}$ and the other part acts on the ν_0 or ν_1 at the end. As $E\nu_0 = 0$ and $E^2\nu_1 = 0$, then we only need to consider the terms of $(\Delta(E))^n$ with no E on the relevant side for ν_0 , or E for ν_1 .

For $\alpha(\rho_{i_1, \dots, i_n, 2p-2} \otimes \nu_0)$, any E acting on the zero at the end will give zero, so we only need consider the action of $E^n \otimes K^n$. Hence we have:

$$\begin{aligned} E^n(\rho_{i_1, \dots, i_n, 2p-2} \otimes \nu_0) &= (E^n \otimes K^n)(\rho_{i_1, \dots, i_n, 2p-2} \otimes \nu_0) = q^n e_n x_{0, 2p-1} \\ \alpha(\rho_{i_1, \dots, i_n, 2p-2} \otimes \nu_0) &= q^n e_n E^{p-n-1} x_{2p-1, 2p-1} \end{aligned}$$

For $\alpha(\rho_{i_1, \dots, i_n, 2p-2} \otimes \nu_1)$, we need an E acting on the one at the right, as well as E^n acting on the left, so we need to consider the term of $(\Delta(E))^{n+1}$ given by $\lambda_{n, n+1} E^n \otimes K^n E$. Hence we have:

$$\begin{aligned} E^{n+1}(\rho_{i_1, \dots, i_n, 2p-2} \otimes \nu_1) &= \lambda_{n, n+1} (E^n \otimes K^n E)(\rho_{i_1, \dots, i_n, 2p-2} \otimes \nu_1) = q^n \lambda_{n, n+1} e_n x_{0, 2p-1} \\ \alpha(\rho_{i_1, \dots, i_n, 2p-2} \otimes \nu_1) &= q^n \lambda_{n, n+1} e_n E^{p-n-2} x_{2p-1, 2p-1} \end{aligned}$$

For $\alpha(\nu_{0i_1 i_2 \dots i_{2p-2}})$, we use the term $1 \otimes E^n$ to get:

$$\begin{aligned} E^n(\nu_0 \otimes \rho_{i_1, \dots, i_n, 2p-2}) &= (1 \otimes E^n)(\nu_0 \otimes \rho_{i_1, \dots, i_n, 2p-2}) = e_n x_{0, 2p-1} \\ \alpha(\nu_0 \otimes \rho_{i_1, \dots, i_n, 2p-2}) &= e_n E^{p-n-1} x_{2p-1, 2p-1} \end{aligned}$$

Finally for $\alpha(\nu_1 \otimes \rho_{i_1, \dots, i_n, 2p-2})$, we need an E to act on the left, so we use the term $\lambda_{1, n+1} E \otimes K E^n$ that appears in $(\Delta(E))^{n+1}$, which gives:

$$\begin{aligned} E^{n+1}(\nu_1 \otimes \rho_{i_1, \dots, i_n, 2p-2}) &= \lambda_{1, n+1} (E \otimes K E^n)(\nu_1 \otimes \rho_{i_1, \dots, i_n, 2p-2}) = q^{2p-2} \lambda_{1, n+1} e_n x_{0, 2p-1} \\ \alpha(\nu_1 \otimes \rho_{i_1, \dots, i_n, 2p-2}) &= q^{2p-2} \lambda_{1, n+1} e_n E^{p-n-2} x_{2p-1, 2p-1} \end{aligned}$$

Hence the relation becomes:

$$\begin{aligned} & q^{n-1}\lambda_{n,n+1}e_n(E^{p-n-2}x_{2p-1,2p-1}) \otimes \nu_0 - q^n e_n(E^{p-n-1}x_{2p-1,2p-1}) \otimes \nu_1 \\ &= q^{-1}e_n\nu_1 \otimes (E^{p-n-1}x_{2p-1,2p-1}) - q^{2p-2}\lambda_{1,n+1}e_n\nu_0 \otimes (E^{p-n-2}x_{2p-1,2p-1}) \end{aligned}$$

Note that $\lambda_{1,n+1} = \lambda_{n,n+1} = q^{-n}[n+1]$, so we have:

$$\begin{aligned} & q^{-1}[n+1](E^{p-n-2}x_{2p-1,2p-1}) \otimes \nu_0 - q^n(E^{p-n-1}x_{2p-1,2p-1}) \otimes \nu_1 \\ &= q^{-1}\nu_1 \otimes (E^{p-n-1}x_{2p-1,2p-1}) - q^{2p-2-n}[n+1]\nu_0 \otimes (E^{p-n-2}x_{2p-1,2p-1}) \end{aligned}$$

We want to show that both sides of this relation are actually equal to $q^{-1}E^{p-n-1}x_{2p,2p}$.

Before we proceed further, we need equation A.17:

$$E^n x_{z,z} = \sum_{1 \leq i_j \leq z} q^{\left(\frac{1}{2}(z-n)(z-n+1) - \sum_{j=1}^{z-n} i_j\right)} ([n]!) \rho_{i_1, \dots, i_{z-n}, z}$$

Using this, we can rewrite $E^n x_{z+1, z+1}$ as:

$$\begin{aligned} E^n x_{z+1, z+1} &= \sum_{1 \leq i_j \leq z+1} q^{\left(\frac{1}{2}(z+1-n)(z-n+2) - \sum_{j=1}^{z+1-n} i_j\right)} ([n]!) \rho_{i_1, \dots, i_{z+1-n}, z+1} \\ &= \sum_{1 \leq i_j \leq z} q^{\left(\frac{1}{2}(z+1-n)(z-n+2) - \sum_{j=1}^{z+1-n} i_j\right)} ([n]!) \rho_{i_1, \dots, i_{z+1-n}, z} \otimes \nu_0 \\ &\quad + q^{\left(\frac{1}{2}(z+1-n)(z-n+2) - z - 1 - \sum_{j=1}^{z-n} i_j\right)} ([n]!) \rho_{i_1, \dots, i_{z-n}, z} \otimes \nu_1 \\ &= [n](E^{n-1}x_{z,z}) \otimes \nu_0 + q^{-n}(E^n x_{z,z}) \otimes \nu_1 \end{aligned}$$

Hence we have that:

$$q^{-1}[n+1](E^{p-n-2}x_{2p-1,2p-1}) \otimes \nu_0 - q^n(E^{p-n-1}x_{2p-1,2p-1}) \otimes \nu_1 = q^{-1}E^{p-n-1}x_{2p,2p}$$

Alternatively, we can rewrite $E^{n+1}x_{z+1, z+1}$ as:

$$\begin{aligned} E^n x_{z+1, z+1} &= \sum_{1 \leq i_j \leq z+1} q^{\left(\frac{1}{2}(z+1-n)(z-n+2) - \sum_{j=1}^{z+1-n} i_j\right)} ([n]!) \rho_{i_1, \dots, i_{z+1-n}, z+1} \\ &= \sum_{2 \leq i_j \leq z+1} q^{\left(\frac{1}{2}(z+1-n)(z-n+2) - \sum_{j=1}^{z+1-n} i_j\right)} ([n]!) \nu_0 \otimes \rho_{i_1-1, \dots, i_{z+1-n}-1, z} \\ &\quad + q^{\left(\frac{1}{2}(z+1-n)(z-n+2) - 1 - \sum_{j=2}^{z+1-n} i_j\right)} ([n]!) \nu_1 \otimes \rho_{i_2-1, \dots, i_{z+1-n}-1, z} \\ &= q^{n-z-1}[n]\nu_0 \otimes (E^{n-1}x_{z,z}) + \nu_1 \otimes (E^n x_{z,z}) \end{aligned}$$

Note that we had to account for the changing positions of the i_j .

Hence we have that:

$$q^{-1}\nu_1 \otimes (E^{p-n-1}x_{2p-1,2p-1}) - q^{2p-2-n}[n+1]\nu_0 \otimes (E^{p-n-2}x_{2p-1,2p-1}) = q^{-1}E^{p-n-1}x_{2p,2p}$$

and so both sides of the relation are equal to $q^{-1}E^{p-n-1}x_{2p,2p}$.

Hence we have shown that $\alpha_1 \cap_{2p-1} = \alpha_2 \cap_1$.

We want to repeat this for β . Explicitly, we want to show that

$\beta_1(\cap_{2p}(\rho_{i_1, \dots, i_n, 2p-2})) = \beta_2(\cap_1(\rho_{i_1, \dots, i_n, 2p-2}))$. We can rewrite this as:

$$\begin{aligned} & q^{-1}\beta(\rho_{i_1, \dots, i_n, 2p-2} \otimes \nu_1) \otimes \nu_0 - \beta(\rho_{i_1, \dots, i_n, 2p-2} \otimes \nu_0) \otimes \nu_1 \\ &= q^{-1}\nu_1 \otimes \beta(\nu_0 \otimes \rho_{i_1, \dots, i_n, 2p-2}) - \nu_0 \otimes \beta(\nu_1 \otimes \rho_{i_1, \dots, i_n, 2p-2}) \end{aligned}$$

To simplify this, we need equation A.10:

$$(\Delta(F))^n = \sum_{i=0}^n \lambda_{i,n} K^{-i} F^{n-i} \otimes F^i$$

where $\lambda_{i,n} = q^{(i^2-in)} \frac{(n!)}{([i]!([n-i]!))}$.

Given $F^n \nu_{i_1 i_2 \dots i_{2p-2}} = f_n x_{2p-2, 2p-2}$, then we only need to consider the relevant part of $(\Delta(F))^n$ where one part of the coproduct acts on $\rho_{i_1, \dots, i_n, 2p-2}$ and the other part acts on the ν_0 or ν_1 at the end. As $F^2 \nu_0 = 0$, $F \nu_1 = 0$, we only need to consider the terms of $(\Delta(F))^n$ with one F on the relevant side for ν_0 , of no F for ν_1 .

For $\beta(\rho_{i_1, \dots, i_n, 2p-2} \otimes \nu_1)$, any F acting on the one at the end will give zero, hence we only need to consider the action of $F^n \otimes 1$. Hence we have:

$$\begin{aligned} F^n(\rho_{i_1, \dots, i_n, 2p-2} \otimes \nu_1) &= (F^n \otimes 1)(\rho_{i_1, \dots, i_n, 2p-2} \otimes \nu_1) = f_n x_{2p-1, 2p-1} \\ \beta(\rho_{i_1, \dots, i_n, 2p-2} \otimes \nu_1) &= f_n F^{p-n-1} x_{0, 2p-1} \end{aligned}$$

For $\beta(\rho_{i_1, \dots, i_n, 2p-2} \otimes \nu_0)$, we need an F to act on the zero on the right. Hence we need to consider the action of the term $\lambda_{1, n+1}(K^{-1}F^n \otimes F)$. Note that this appears in $(\Delta(F))^{n+1}$.

Hence we have:

$$\begin{aligned} F^{n+1}(\rho_{i_1, \dots, i_n, 2p-2} \otimes \nu_0) &= \lambda_{1, n+1}(K^{-1}F^n \otimes F)(\rho_{i_1, \dots, i_n, 2p-2} \otimes \nu_0) = q^{2p-2} f_n \lambda_{1, n+1} x_{2p-1, 2p-1} \\ \beta(\rho_{i_1, \dots, i_n, 2p-2} \otimes \nu_0) &= q^{2p-2} f_n \lambda_{1, n+1} F^{p-n-2} x_{0, 2p-1} \end{aligned}$$

For $\beta(\nu_1 \otimes \rho_{i_1, \dots, i_n, 2p-2})$, we consider the action of $K^{-n} \otimes F^n$ in $(\Delta(F))^n$. This gives:

$$\begin{aligned} F^n(\nu_1 \otimes \rho_{i_1, \dots, i_n, 2p-2}) &= (K^{-n} \otimes F^n)(\nu_1 \otimes \rho_{i_1, \dots, i_n, 2p-2}) = q^n f_n x_{2p-1, 2p-1} \\ \beta(\nu_1 \otimes \rho_{i_1, \dots, i_n, 2p-2}) &= q^n f_n F^{p-n-1} x_{0, 2p-1} \end{aligned}$$

Finally for $\beta(\nu_0 \otimes \rho_{i_1, \dots, i_n, 2p-2})$, we need an F to act on the zero on the left. Hence we consider the action of $\lambda_{n, n+1}(K^{-n} F \otimes F^n)$ that appears in $(\Delta(F))^{n+1}$. Hence we have:

$$\begin{aligned} F^{n+1}(\nu_0 \otimes \rho_{i_1, \dots, i_n, 2p-2}) &= \lambda_{n, n+1}(K^{-n} F \otimes F^n)(\nu_0 \otimes \rho_{i_1, \dots, i_n, 2p-2}) = q^n f_n \lambda_{n, n+1} x_{2p-1, 2p-1} \\ \beta(\nu_0 \otimes \rho_{i_1, \dots, i_n, 2p-2}) &= q^n f_n \lambda_{n, n+1} F^{p-n-2} x_{0, 2p-1} \end{aligned}$$

Hence we can rewrite the relation as:

$$\begin{aligned} q^{-1} f_n (F^{p-n-1} x_{0, 2p-1}) \otimes \nu_0 - q^{2p-2} f_n \lambda_{1, n+1} (F^{p-n-2} x_{0, 2p-1}) \otimes \nu_1 \\ = q^{n-1} f_n \lambda_{n, n+1} \nu_1 \otimes (F^{p-n-2} x_{0, 2p-1}) - q^n f_n \nu_0 \otimes (F^{p-n-1} x_{0, 2p-1}) \end{aligned}$$

We want to show that both sides of this relation are equal to $q^{-1} F^{p-n-1} x_{0, 2p}$.

Before we proceed further, we need equation A.15:

$$F^n x_{0, z} = \sum_{1 \leq i_j \leq z} q^{\left(\frac{1}{2}(n^2+n) - \sum_{j=1}^n i_j\right)} ([n]!) \rho_{i_1, \dots, i_n, z}$$

Using this, we can rewrite $F^n x_{0, z+1}$ as:

$$\begin{aligned} F^n x_{0, z+1} &= \sum_{1 \leq i_j \leq z+1} q^{\left(\frac{1}{2}(n^2+n) - \sum_{j=1}^n i_j\right)} ([n]!) \rho_{i_1, \dots, i_n, z+1} \\ &= \sum_{1 \leq i_j \leq z} q^{\left(\frac{1}{2}(n^2+n) - \sum_{j=1}^n i_j\right)} ([n]!) \rho_{i_1, \dots, i_n, z} \otimes \nu_0 \\ &\quad + q^{\left(\frac{1}{2}(n^2+n) - z - 1 - \sum_{j=1}^{n-1} i_j\right)} ([n]!) \rho_{i_1, \dots, i_{n-1}, z} \otimes \nu_1 \\ &= (F^n x_{0, z}) \otimes \nu_0 + q^{n-z-1} [n] (F^{n-1} x_{0, z}) \otimes \nu_1 \end{aligned}$$

Hence we have that:

$$q^{-1} (F^{p-n-1} x_{0, 2p-1}) \otimes \nu_0 - q^{-n-2} [n+1] (F^{p-n-2} x_{0, 2p-1}) \otimes \nu_1 = q^{-1} F^{p-n-1} x_{0, 2p}$$

Alternatively, we have that:

$$\begin{aligned} F^n x_{0, z+1} &= \sum_{1 \leq i_j \leq z+1} q^{\left(\frac{1}{2}(n^2+n) - \sum_{j=1}^n i_j\right)} ([n]!) \rho_{i_1, \dots, i_n, z+1} \\ &= \sum_{2 \leq i_j \leq z+1} q^{\left(\frac{1}{2}(n^2+n) - \sum_{j=1}^n i_j\right)} ([n]!) \nu_0 \otimes \rho_{i_1-1, \dots, i_n-1, z} \\ &\quad + q^{\left(\frac{1}{2}(n^2+n) - 1 - \sum_{j=2}^n i_j\right)} ([n]!) \nu_1 \otimes \rho_{i_2-1, \dots, i_n-1, z} \\ &= q^{-n} \nu_0 \otimes (F^n x_{0, z}) + [n] \nu_1 \otimes (F^{n-1} x_{0, z}) \end{aligned}$$

Hence we have that:

$$q^{-1}[n+1]\nu_1 \otimes (F^{p-n-2}x_{0,2p-1}) - q^n\nu_0 \otimes (F^{p-n-1}x_{0,2p-1}) = q^{-1}F^{p-n-1}x_{0,2p}$$

and so both sides of the relation are equal to $q^{-1}F^{p-n-1}x_{0,2p}$, and we have shown that $\beta_1 \cap_{2p-1} = \beta_2 \cap_1$.

Given this relation and the equivalent one for α , we can prove the following diagrammatically:

$$\cup_{2p-1}\alpha_1 = \cup_1\alpha_2$$

$$\cup_{2p-1}\beta_1 = \cup_1\beta_2$$

For α , we have:

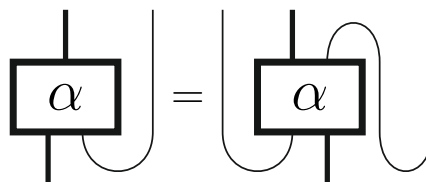
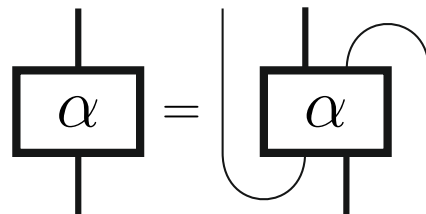
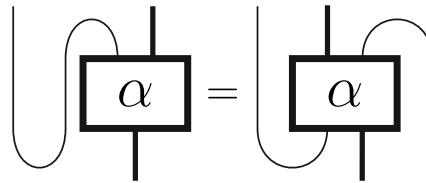
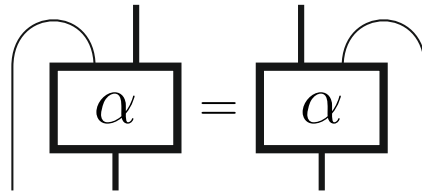

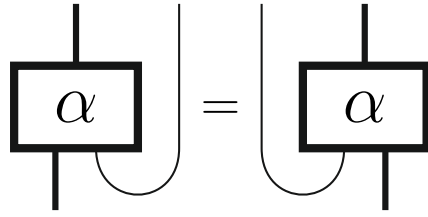

The proof for β follows similarly.

We can also use the capping relations to show that the partial traces of α and β are zero.

For α we have:

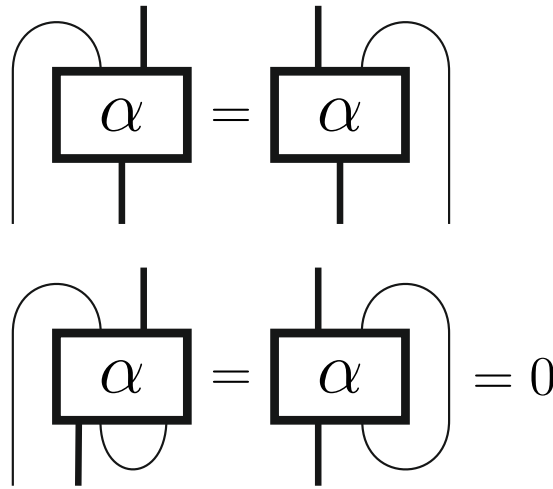

The case for β follows similarly.

5.4.2 Relations from the Rotation tangle

In section 5.4.1, we saw that α and β are rotation invariant. We want to use this to give a relation using the rotation tangle acting on $\alpha \otimes 1$ and $\beta \otimes 1$. As an example, acting the (clockwise) rotation tangle on $\alpha \otimes 1$ for $p = 2$, we get:

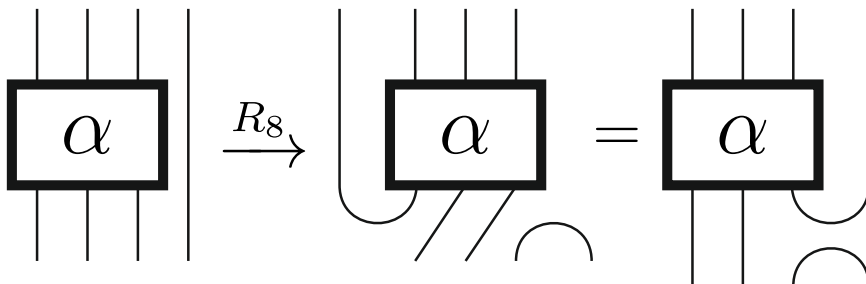

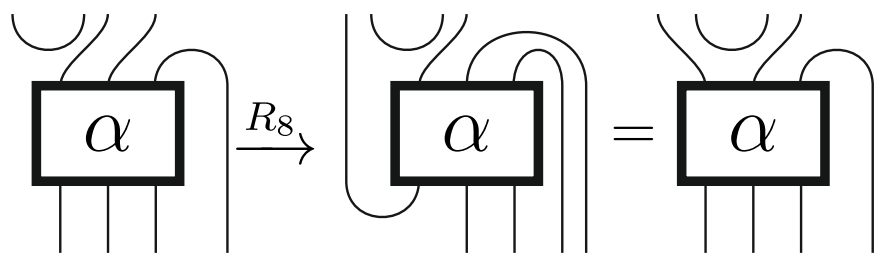
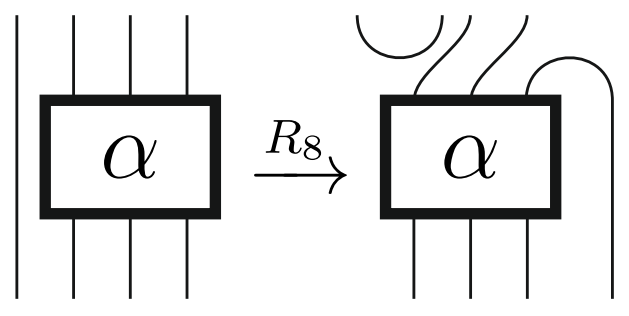
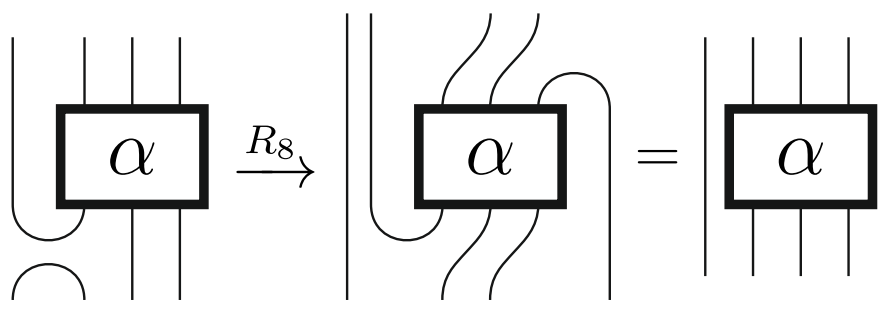
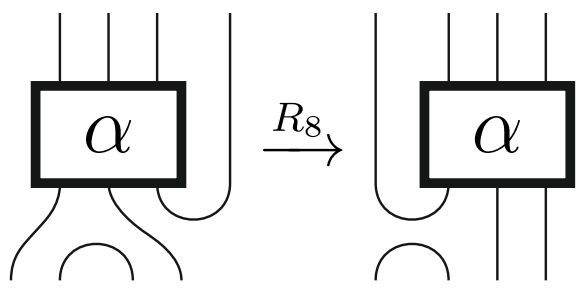
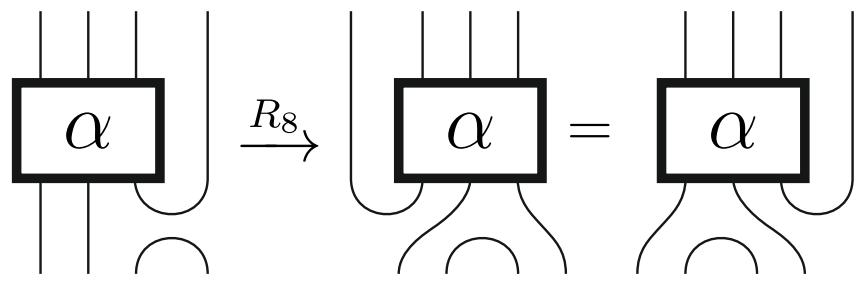

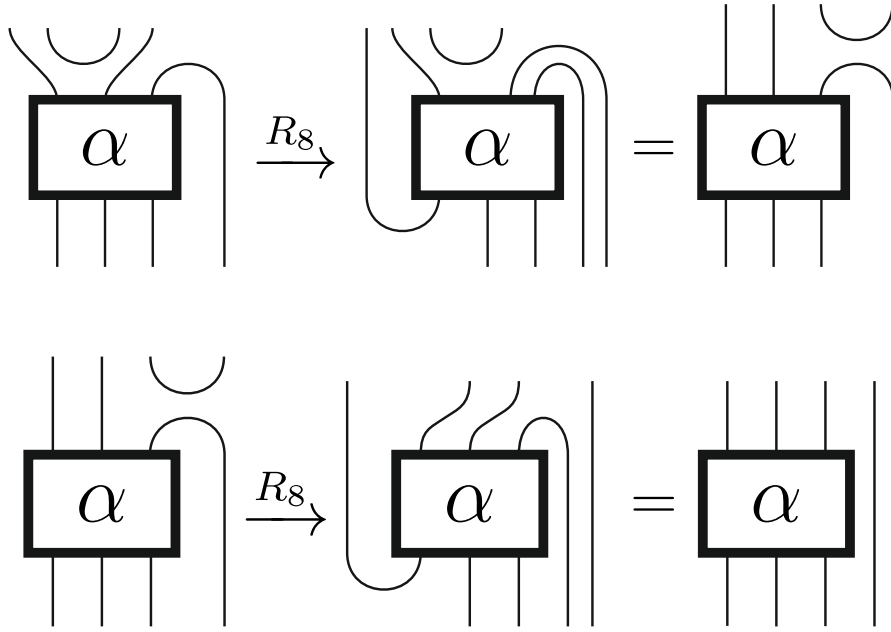

where the rotation tangle R_8 is:

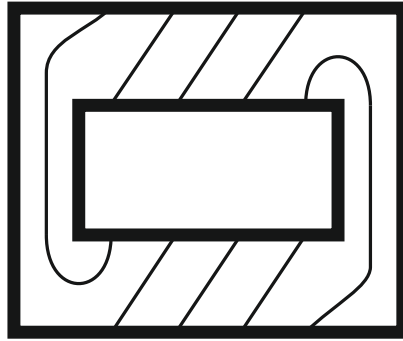

Denote the rotation tangle by R_{4p} , then we have:

$$\begin{aligned}
 R_{4p}(\alpha_1) &= \alpha_1 \mathbf{e}_{2p-1} \\
 R_{4p}^2(\alpha_1) &= \alpha_1 \mathbf{e}_{2p-1} \mathbf{e}_{2p-2} \\
 R_{4p}^{2p-1}(\alpha_1) &= \alpha_1 \mathbf{e}_{2p-1} \mathbf{e}_{2p-2} \dots \mathbf{e}_1 \\
 R_{4p}^{2p}(\alpha_1) &= \alpha_2 \\
 R_{4p}^{2p+1}(\alpha_1) &= \mathbf{e}_1 \alpha_2 \\
 R_{4p}^{2p+2}(\alpha_1) &= \mathbf{e}_2 \mathbf{e}_1 \alpha_2 \\
 R_{4p}^{4p-1}(\alpha_1) &= \mathbf{e}_{2p-1} \mathbf{e}_{2p-2} \dots \mathbf{e}_1 \alpha_2 \\
 R_{4p}^{4p}(\alpha_1) &= \alpha_1
 \end{aligned}$$

and similarly for β .

Consider the sum $P_{\alpha_1} := \sum_{i=0}^{4p-1} k_i R_{4p}^i(\alpha_1)$. Assume that $P_{\alpha_1} = 0$. Then by considering $\cup_{2p-1} P_{\alpha_1}$, we find $k_1 + \delta k_2 + k_3 = 0$. Repeating this for each position, we get $k_i + \delta k_{i+1} + k_{i+2} = 0$ for all i , where we take $k_{4p+1} := k_1$.

We need to show that the k_i are non-zero. We do this by showing that the $R_{4p}^i(\alpha_1)$ are linearly-dependent. Note that each $R_{4p}^i(\alpha_1)$ acts on the K -weight spaces by

$R_{4p}^i(\alpha_1) : X_{n,2p} \rightarrow X_{n+p,2p}$. We have previously given all homomorphisms between indecomposable modules in section 4.4, and from this we see that each map can only act as $X_{n,z} \rightarrow X_{n,z}$, except for the maps between \mathcal{P}_s^+ and \mathcal{P}_{p-s}^- . Hence as we are considering maps acting on $(\mathcal{X}_2^+)^{\otimes 2p}$, we only need consider the maps between \mathcal{P}_1^+ and \mathcal{P}_{p-1}^- , as well as maps between the two copies of \mathcal{P}_{p-1}^- .

As an example, for $p = 3$, in terms of weight spaces, the modules \mathcal{P}_1^+ and \mathcal{P}_2^- can be given as:

$$\begin{array}{cccccc}
 & & & \mathcal{P}_1^+ & & & \\
 & & & \underbrace{\hspace{10em}} & & & \\
 & X_{1,6} & X_{2,6} & X_{3,6} & X_{4,6} & X_{5,6} & \\
 & x_0 & x_1 & \{a, b\} & y_0 & y_1 & \\
 \\
 X_{0,6} & X_{1,6} & X_{2,6} & X_{3,6} & X_{4,6} & X_{5,6} & X_{6,6} \\
 x & \{a_0, b_0\} & \{a_1, b_1\} & \{x, y\} & \{a_0, b_0\} & \{a_1, b_1\} & y \\
 & \underbrace{\hspace{10em}} & & \underbrace{\hspace{10em}} & & & \\
 & \mathcal{P}_2^- & & \mathcal{P}_2^- & & &
 \end{array}$$

The possible maps (omitting maps acting as $X_{n,2p} \rightarrow X_{n,2p}$) are then given as:

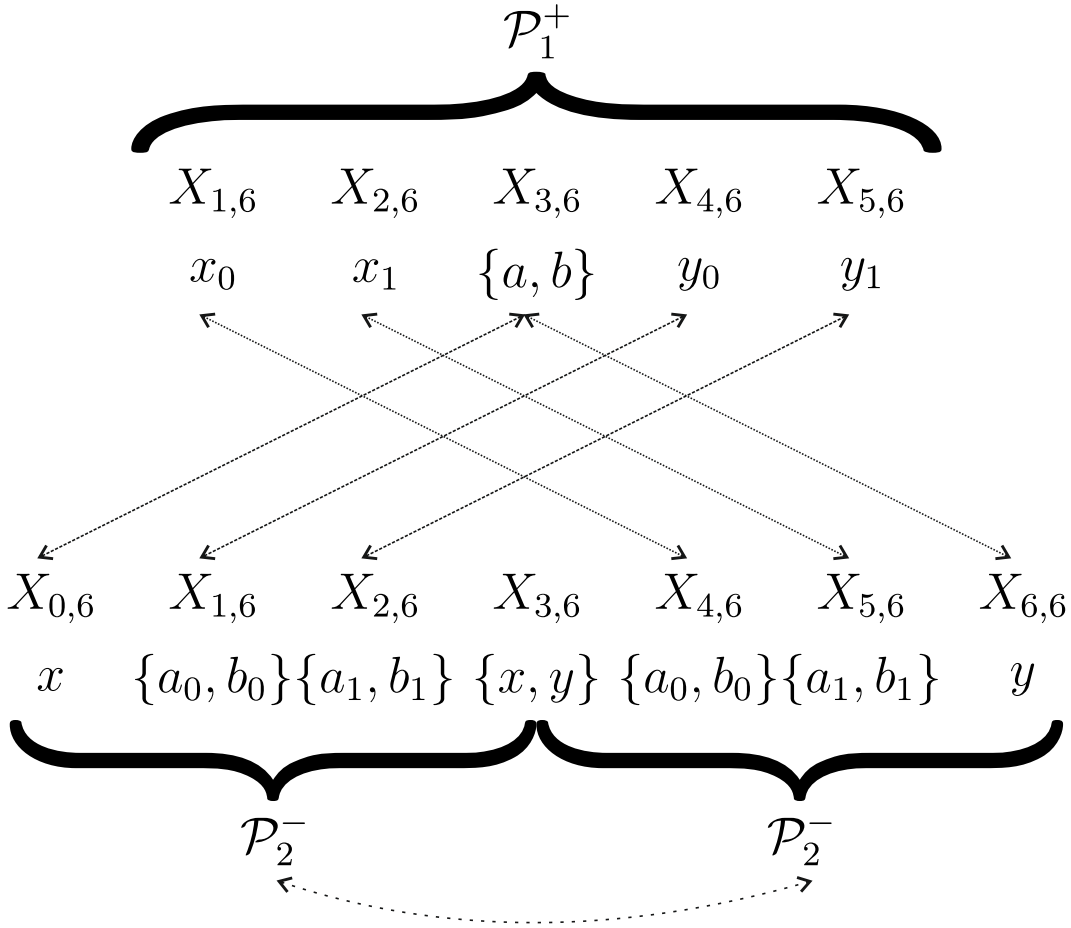

Hence there are two maps acting as $X_{n,2p} \rightarrow X_{n+p,2p}$, and two acting as $X_{n,2p} \rightarrow X_{n-p,2p}$. There are also two maps from the first copy of \mathcal{P}_2^- to the second, and vice-versa (as there are two endomorphisms on \mathcal{P}_{p-1}^-), however these can be given as a composition of the other maps and a map acting as $X_{n,2p} \rightarrow X_{n,2p}$. Note that this accounts for the multiplicity of \mathcal{P}_2^- , but not for the multiplicity of \mathcal{P}_1^+ . So the total number of maps acting as $X_{n,2p} \rightarrow X_{n+p,2p}$ is $2M(\mathcal{P}_1^+)$. From this we can conclude that the diagrams $R_{4p}^i(\alpha_1)$ must be linearly-dependent if $2M(\mathcal{P}_1^+) < 4p$. From the module multiplicity formulae given previously in section 4.3, we can see that $M(\mathcal{P}_1^+)$ in $(\mathcal{X}_2^+)^{\otimes 2p}$ is $\begin{Bmatrix} 2p-1 \\ 1 \end{Bmatrix} = 2p-2$. Hence, there are $4p-4$ maps acting as $X_{n,2p} \rightarrow X_{n+p,2p}$, and so the $R_{4p}^i(\alpha_1)$ are linearly dependent.

By the same argument, we have that the terms $R_{4p}^i(\beta_1)$ are linearly dependent.

The Coefficients k_i

We want to show that the coefficients k_i satisfy $k_{p+1} = (-1)^{p+1}k_1$. For this, we need a specialisation of equation A.1:

$$[m+1] = 2[m] - [m-1]$$

Given $k_i = -\delta k_{i-1} - k_{i-2}$, we can rewrite this as:

$$k_i = (-1)^i Q_i k_2 + (-1)^i Q_{i-1} k_1$$

where $Q_0 = -1$, $Q_1 = 0$, $Q_i = \delta Q_{i-1} - Q_{i-2}$. Then, as $Q_2 = 1$, we have $Q_i = [i-1]$, and so $Q_p = -1$, $Q_{p+1} = 0$. This then becomes:

$$k_i = (-1)^i [i-1] k_2 + (-1)^i [i-2] k_1$$

Hence:

$$\begin{aligned} k_{p+1} &= (-1)^{p+1} [p] k_2 + (-1)^{p+1} [p-1] k_1 \\ &= (-1)^{p+1} k_1 \end{aligned}$$

Hence, in general $k_{p+i} = (-1)^{p+1} k_i$, $k_{2p+i} = k_i$.

Using this, we can write any of the k_i in terms of k_1 and k_2 . For example, we get $k_{2p} = (-1)^{2p} [2p-1] k_2 + (-1)^{2p} [2p-2] k_1$.

Some Examples of relations.

We can use the sums P_{α_1} and P_{β_1} to prove new relations. For example, consider $\beta_1 P_{\alpha_1} \beta_1$. As capping or cupping β gives zero, this reduces to:

$$k_1 \beta_1 \alpha_1 \beta_1 + k_2 \beta_1 \alpha_1 \mathbf{e}_{2p-1} \beta_1 + k_{2p+1} \beta_1 \alpha_2 \beta_1 + k_{4p} \beta_1 \mathbf{e}_{2p-1} \alpha_1 \beta_1 = 0$$

Similarly for $\beta_2 P_{\alpha_1} \beta_2$ we get:

$$k_1 \beta_2 \alpha_1 \beta_2 + k_{2p} \beta_2 \alpha_1 \mathbf{e}_{2p-1} \mathbf{e}_{2p-2} \dots \mathbf{e}_1 \beta_2 + k_{2p+1} \beta_2 \alpha_2 \beta_2 + k_{2p+2} \beta_2 \mathbf{e}_1 \mathbf{e}_2 \dots \mathbf{e}_{2p-1} \alpha_1 \beta_2 = 0$$

From $\beta_2 P_{\alpha_1} \beta_1 = 0$ we have:

$$k_1 \beta_2 \alpha_1 \beta_1 + k_{2p} \beta_1 \mathbf{e}_{2p-1} \alpha_1 \beta_1 + k_{2p+1} \beta_2 \alpha_2 \beta_1 + k_{4p} \beta_2 \alpha_2 \mathbf{e}_1 \beta_2 = 0$$

Setting $k_1 = 0$, this reduces to:

$$\beta_1 \mathbf{e}_{2p-1} \alpha_1 \beta_1 = -\beta_2 \alpha_2 \mathbf{e}_1 \beta_2$$

and hence:

$$\beta_2\alpha_1\beta_1 = -\beta_2\alpha_2\beta_1$$

Similarly, from $\beta_1 P_{\alpha_1} \beta_2 = 0$ we have:

$$k_1\beta_1\alpha_1\beta_2 + k_2\beta_1\mathbf{e}_{2p-1}\alpha_1\beta_2 + k_{2p+1}\beta_1\alpha_2\beta_2 + k_{2p+2}\beta_1\alpha_2\mathbf{e}_1\beta_2 = 0$$

Setting $k_1 = 0$, this reduces to:

$$\beta_1\mathbf{e}_{2p-1}\alpha_1\beta_2 = -\beta_1\alpha_2\mathbf{e}_1\beta_2$$

and hence:

$$\beta_1\alpha_1\beta_2 = -\beta_1\alpha_2\beta_2$$

Diagrammatically these are:

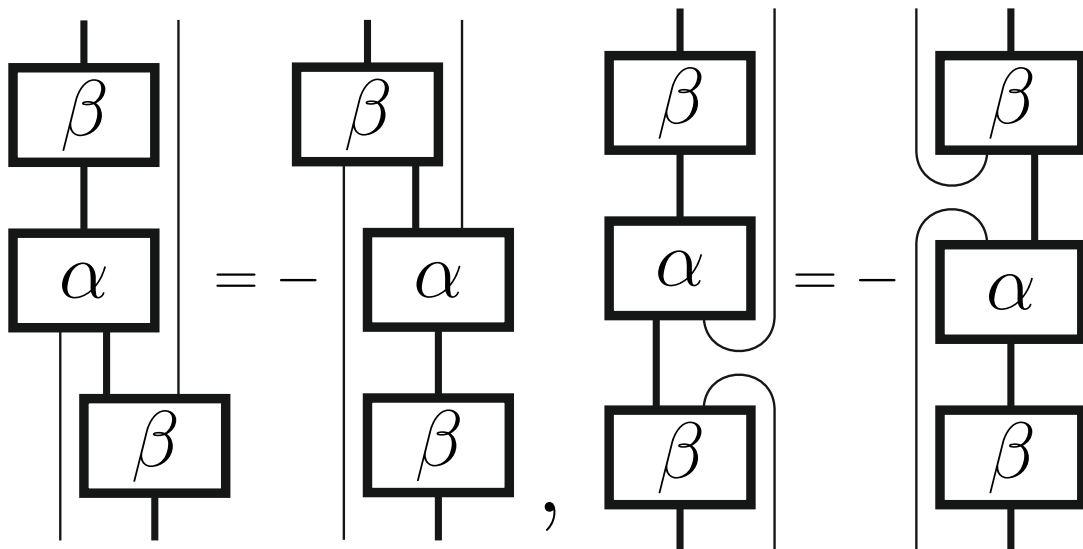
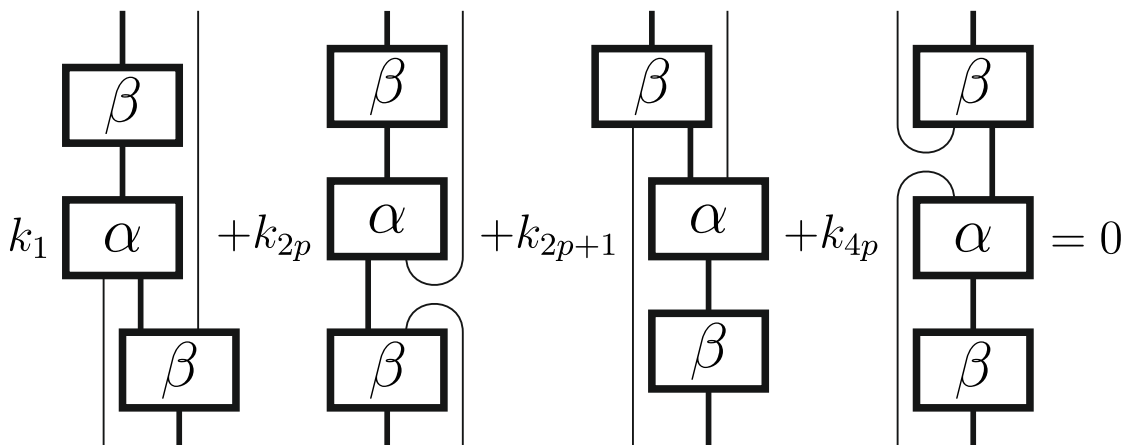

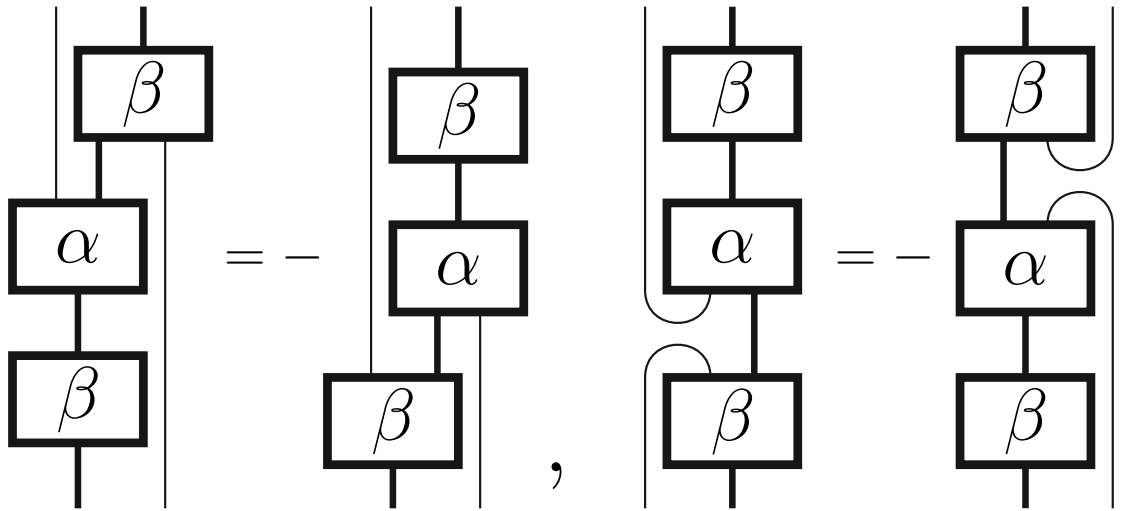
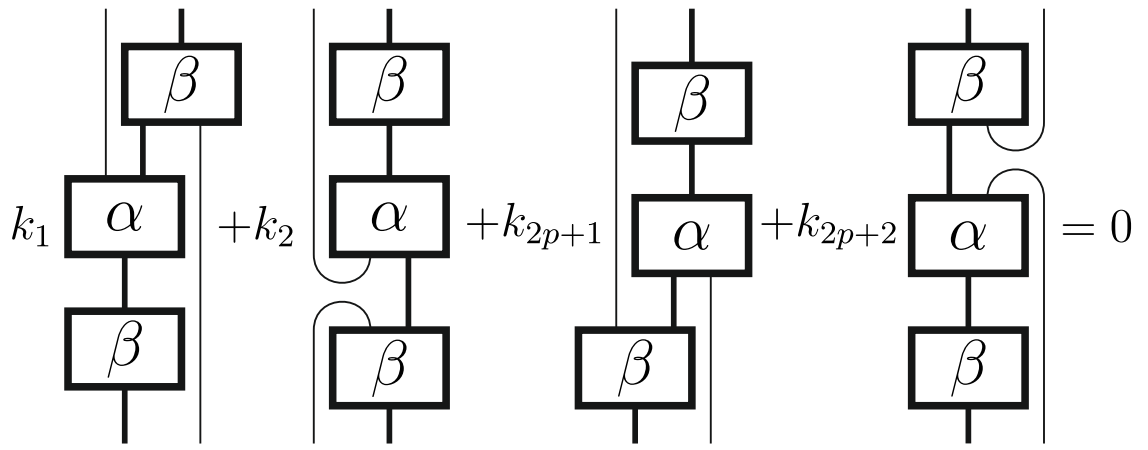

Using this, we find that $\beta_1 P_{\alpha_1} \beta_1 + \beta_2 P_{\alpha_1} \beta_2$ simplifies to give:

$$\beta_1 \alpha_2 \beta_1 + \beta_2 \alpha_1 \beta_2 = -\gamma(\beta_1 + \beta_2)$$

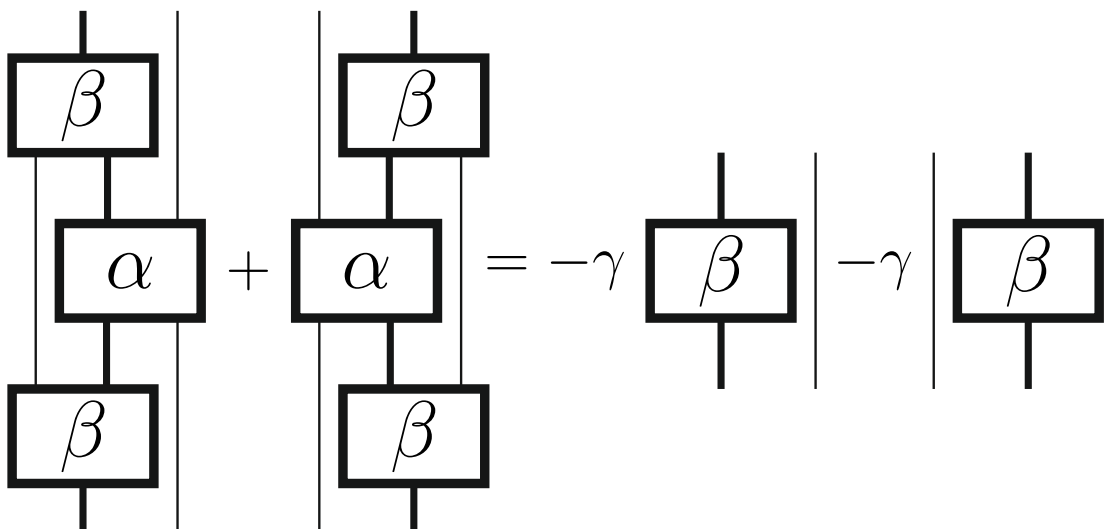

Swapping α and β gives similar relations. Further, considering $\beta_1 P_{\alpha_1} \beta_1$ when $k_1 = 0$

and $k_2 = 1$, giving $k_{4p} = -1$, we have:

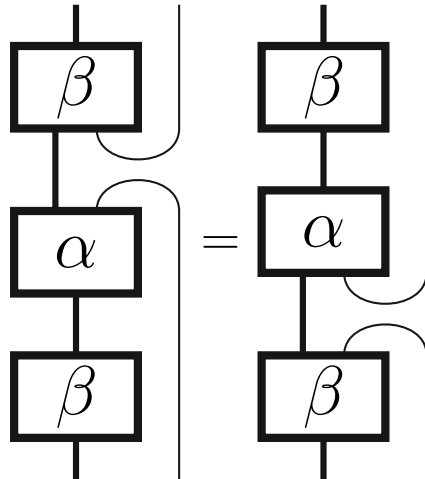

For $\beta_1 P_{\alpha_1} \beta_1$ with $k_1 = 0$, $k_2 = 1$, $k_{4p} = -\delta$:

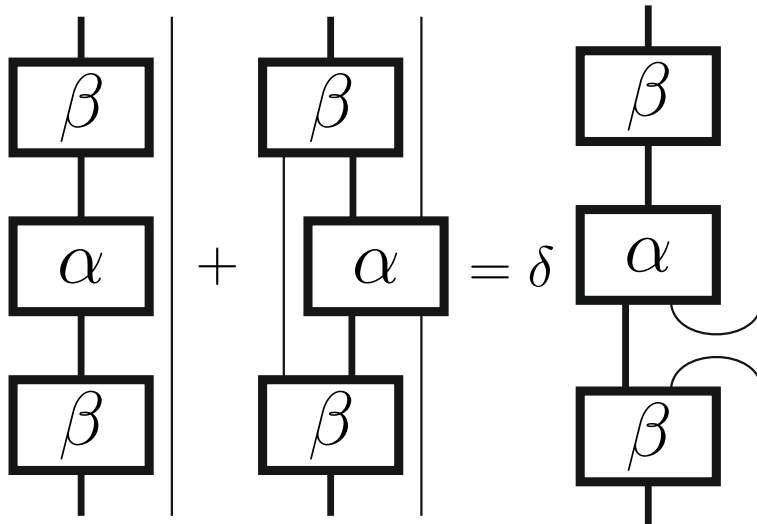

For $\beta_2 P_{\alpha_1} \beta_2$ with $k_1 = 1$, $k_2 = 0$, $k_{2p} = -1$:

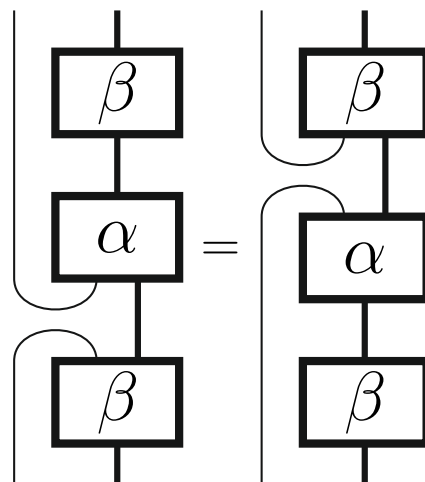

For $\beta_2 P_{\alpha_1} \beta_2$ with $k_1 = 0$, $k_2 = 1$, $k_{2p} = -\delta$:

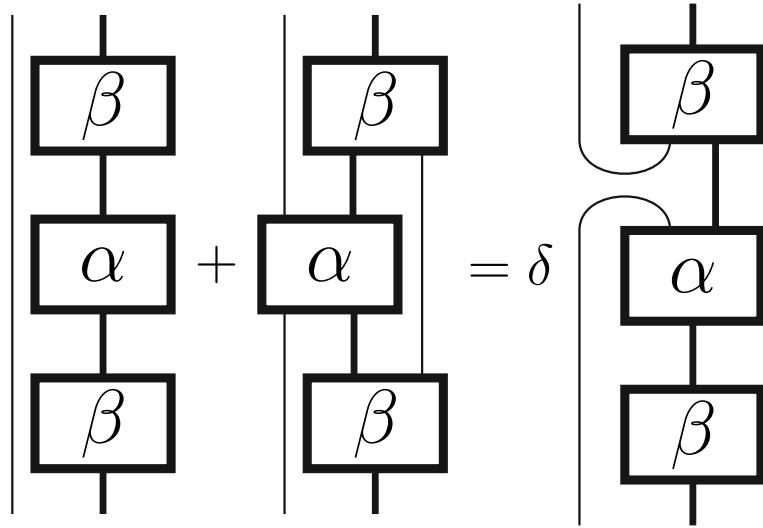

Considering $\alpha_1\beta_1P_{\alpha_1}$ with $k_1 = 1, k_2 = 0$, gives $k_i = (-1)^i[i - 2]$ and:

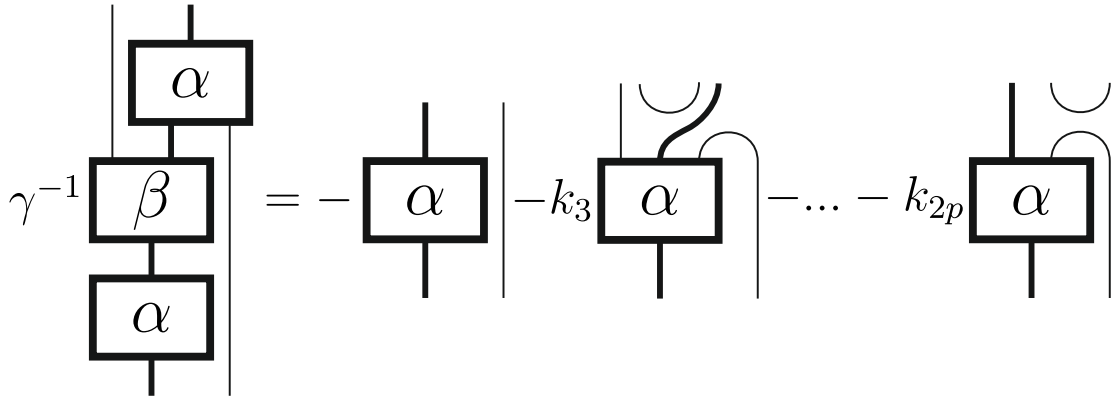

For $\alpha_1\beta_1P_{\alpha_1}$ with $k_1 = 0, k_2 = 1$, gives $k_i = (-1)^i[i - 1]$ and:

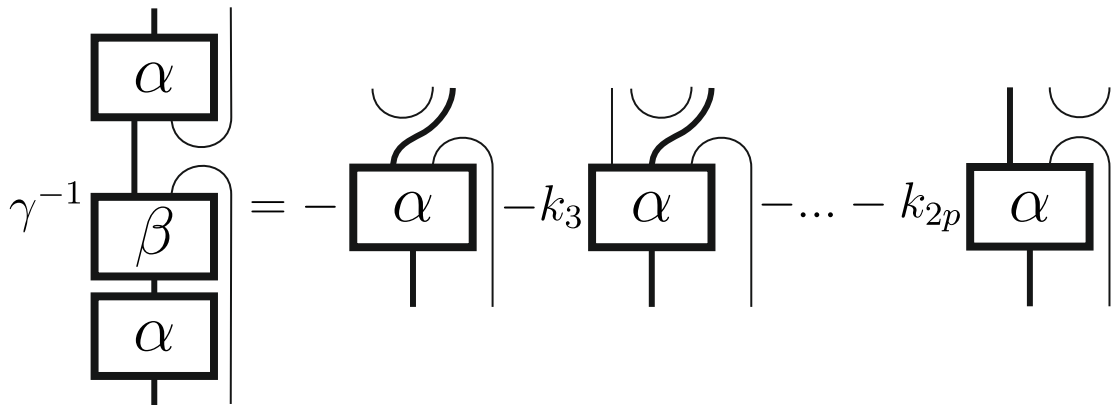

Hence, we can use P_{α_1} and P_{β_1} to reduce compositions of α and β .

We can also use P_{α_1} and P_{β_1} to reduce compositions of α_i and β_j when $|i - j| > 1$.

For example, consider $\beta_3(P_{\alpha_1} \otimes 1)$ with $k_1 = 1, k_{2p-1} = 0$, which gives $k_2 = -\delta^{-1}[3]$,

$k_i = (-1)^{i+1}\delta^{-1}[3][i-1] + (-1)^i[i-2]$ and:

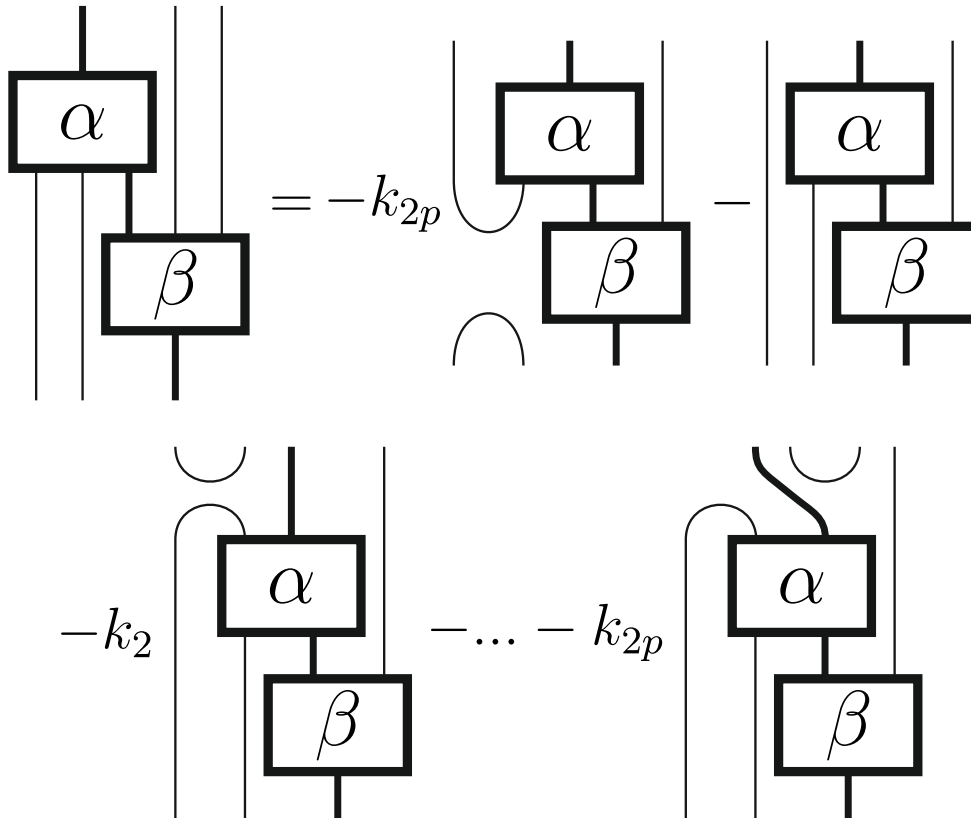

Note that to set $k_1 = 1$ and $k_{2p-1} = 0$, we need that $2p-1 \neq 1 \pmod p$, which isn't true when $p = 2$. Instead, for $p = 2$, we take $k_1 = 1$, $k_2 = 0$, which gives $k_{2i} = 0$, $k_{2i+1} = (-1)^i$ and:

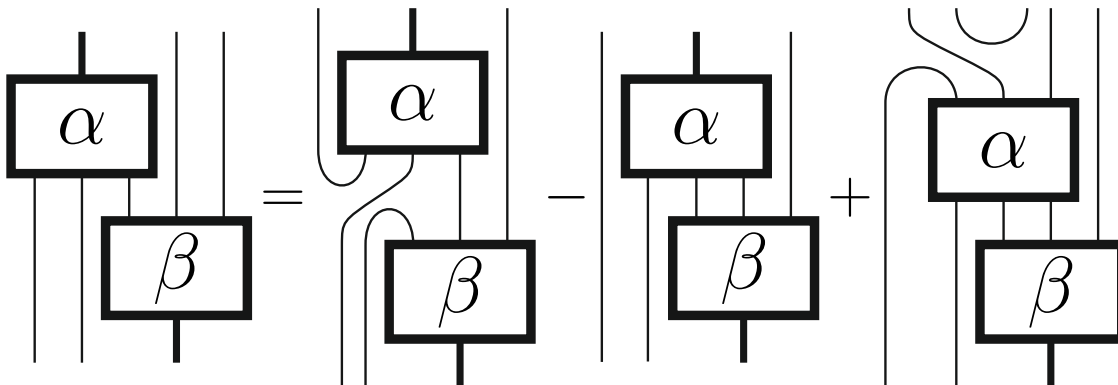

In general, we can't use the rotation relation to reduce diagrams of the form $\alpha_1\beta_{p+1}$, $\beta_1\alpha_{p+1}$. This can be thought of as due to them being a form of "higher generator", that maps between copies of \mathcal{P}_p^+ in $X^{\otimes(3p-1)}$. Indeed, this continues to occur for general $X^{\otimes(np-1)}$.

Chapter 6

Projections and Homomorphisms on Indecomposable Modules.

In the non-restricted case, the Jones-Wenzl projections are the projections onto the simple modules of $U_q(\mathfrak{sl}_2)$. In the restricted case, as we have the appearance of indecomposable modules, we should also have projections onto these modules, as well as homomorphisms between modules. We want to find diagrammatic descriptions for the projections and homomorphisms on the indecomposable modules of $\bar{U}_q(\mathfrak{sl}_2)$.

We start by summarizing the various maps.

6.1 Summary of Projections and Morphisms.

The projection $X^{\otimes n} \rightarrow \mathcal{X}_{n+1}^+ \rightarrow X^{\otimes n}$ for $0 \leq n \leq p-1$ is given by the n th Jones-Wenzl projection. See appendix B for details.

As shown in the previous chapter, the projections $X^{\otimes 2p-1} \rightarrow \mathcal{P}_p^- \rightarrow X^{\otimes 2p-1}$ onto the two copies of \mathcal{P}_p^- are given by $\gamma^{-1}\alpha\beta$ and $\gamma^{-1}\beta\alpha$. The projection $X^{\otimes 2p-1} \rightarrow \mathcal{P}_p^- \oplus \mathcal{P}_p^- \rightarrow X^{\otimes 2p-1}$ is given by the Jones-Wenzl projection f_{2p-1} , where $\gamma f_{2p-1} = \alpha\beta + \beta\alpha$.

The homomorphism $X^{\otimes (2p-i-1)} \rightarrow \mathcal{P}_i^+ \rightarrow \mathcal{X}_i^+ \rightarrow X^{\otimes (i-1)}$, for $1 \leq i \leq p-1$ is given diagrammatically by:

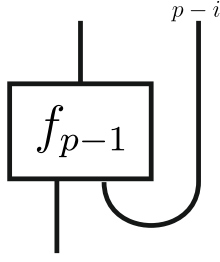

where the box labelled f_{p-1} is the $(p-1)$ th Jones-Wenzl projection.

The homomorphism $X^{\otimes i-1} \rightarrow \mathcal{X}_i^+ \rightarrow \mathcal{P}_i^+ \rightarrow X^{\otimes 2p-i-1}$ is given diagrammatically by:

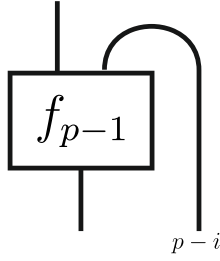

For $1 \leq i \leq p-1$, the set of endomorphisms on \mathcal{P}_i^\pm is two dimensional, and can be given as a projection and a second endomorphism ε , where $\varepsilon^2 = 0$. For \mathcal{P}_i^+ , this second endomorphism $X^{\otimes (2p-i-1)} \rightarrow \mathcal{P}_i^+ \xrightarrow{\varepsilon} \mathcal{P}_i^+ \rightarrow X^{\otimes (2p-i-1)}$ is given diagrammatically by:

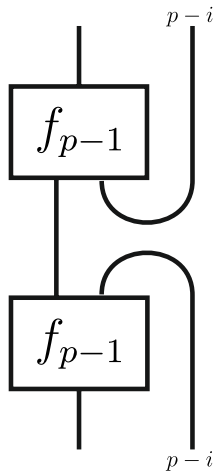

For \mathcal{P}_i^- , accounting for the two copies of \mathcal{P}_i^- , the second endomorphisms $X^{\otimes (3p-i-1)} \rightarrow \mathcal{P}_i^- \xrightarrow{\varepsilon} \mathcal{P}_i^- \rightarrow X^{\otimes (3p-i-1)}$ are given diagrammatically by:

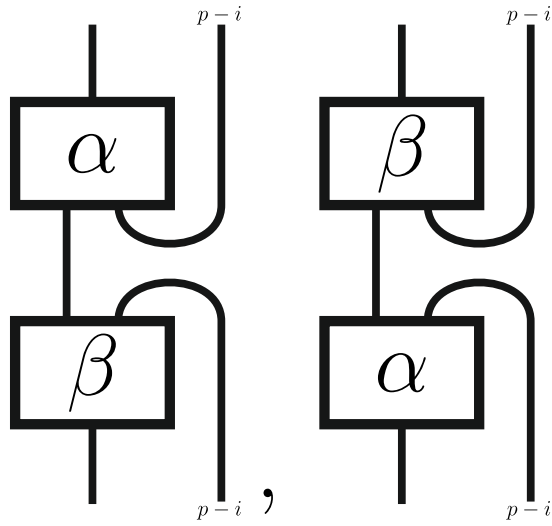

For each copy of \mathcal{P}_{p-i}^- , $1 \leq i \leq p-1$, there are two maps $\mathcal{P}_{p-i}^- \rightarrow \mathcal{P}_i^+$, and two maps $\mathcal{P}_i^+ \rightarrow \mathcal{P}_{p-i}^-$. As there are two copies of \mathcal{P}_{p-i}^- in $X^{\otimes 2p+i-1}$, we then have four maps in each direction. For the four maps $X^{\otimes 2p+i-1} \rightarrow \mathcal{P}_{p-i}^- \rightarrow \mathcal{P}_i^+ \rightarrow X^{\otimes 2p-i-1}$, two of the maps are given diagrammatically by:

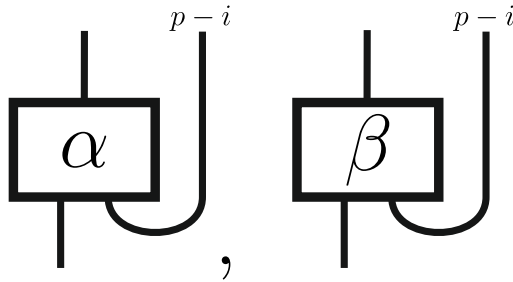

We conjecture that the other two maps are given diagrammatically by:

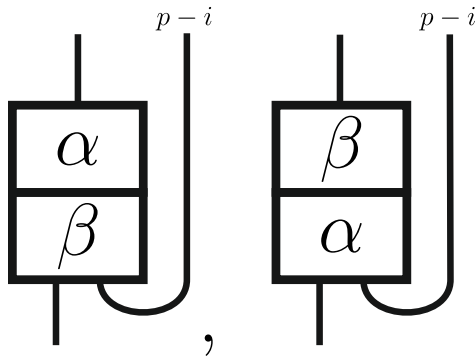

For the four maps $X^{\otimes 2p-i-1} \rightarrow \mathcal{P}_i^+ \rightarrow \mathcal{P}_{p-i}^- \rightarrow X^{\otimes 2p+i-1}$, two are given diagrammatically by:

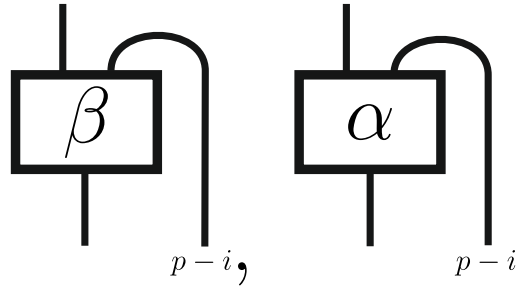

We conjecture that the other two maps are given by:

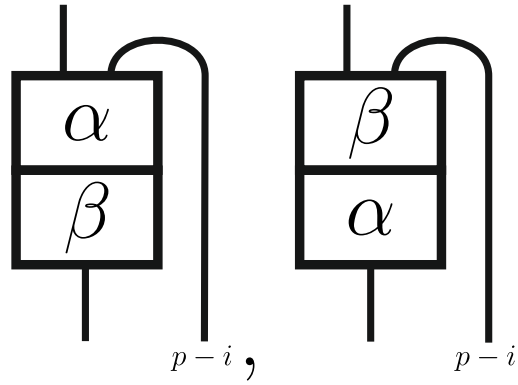

Finally, we conjecture that the projections onto \mathcal{P}_i^+ are given by:

$$\mathcal{P}_i^+ := f_{2p-i-1} + \frac{[i]}{[p]}$$

The diagram shows two rectangular boxes stacked vertically, both labeled with f_{p-1} . A vertical line enters the top of the upper box from the left and exits the bottom of the lower box. A second vertical line enters the top of the upper box from the right, loops back to the top of the upper box, and then exits the bottom of the lower box. The label $p-i$ is placed above the right vertical line, and another label $p-i$ is placed below the right vertical line.

and the projections onto $\mathcal{P}_i^- \oplus \mathcal{P}_i^-$ are given by:

$$\mathcal{P}_i^- \oplus \mathcal{P}_i^- := f_{3p-i-1} + \frac{[p+i]}{[2p]}$$

The remainder of this chapter is devoted to proving these results, as well as further describing the conjectures. We also prove a result stated in section 5.2 of the previous chapter about the partial trace of $\alpha\beta$ and $\beta\alpha$.

6.2 Formula for maps on \mathcal{P}_i^+ .

To prove the diagrammatic forms of the maps $\mathcal{X}_i^+ \rightarrow \mathcal{P}_i^+$, $\mathcal{P}_i^+ \rightarrow \mathcal{X}_i^+$, we first need to describe the maps $X^{\otimes 2p-i-1} \rightarrow \mathcal{P}_i^+$, $\mathcal{P}_i^+ \rightarrow X^{\otimes 2p-i-1}$ in terms of their bases. Although we are not able to do this fully, we can describe it enough to allow us to prove the first three diagram relations in section 6.1.

6.2.1 General Formula for the map $\theta : X^{\otimes 2p-i-1} \rightarrow \mathcal{P}_i^+$

\mathcal{P}_i^+ has basis $\{\tilde{x}_0, \dots, \tilde{x}_{p-i-1}, \tilde{a}_0, \dots, \tilde{a}_{i-1}, \tilde{b}_0, \dots, \tilde{b}_{i-1}, \tilde{y}_0, \dots, \tilde{y}_{p-i-1}\}$.

Let $\rho_{i_1, \dots, i_n, z} \in X_{n, z}$ be the element with ones at positions i_1, \dots, i_n and zeros elsewhere.

We note equation A.12:

$$E^n \rho_{i_1, \dots, i_n, z} = q^{\binom{nz - \frac{1}{2}(n^2 - n) - (\sum_{j=1}^n i_j)}{[n]!}} ([n]!) x_{0, z}$$

By comparing weight spaces, we find that the general form for θ is:

$$\begin{aligned} \theta(\rho_{i_1, \dots, i_n, 2p-i-1}) &= c_n^{(i_1, \dots, i_n)} \tilde{x}_n, \quad 0 \leq n \leq p-i-1 \\ \theta(\rho_{i_1, \dots, i_n, 2p-i-1}) &= d_{n+i-p}^{(i_1, \dots, i_n)} \tilde{a}_{n+i-p} + e_{n+i-p}^{(i_1, \dots, i_n)} \tilde{b}_{n+i-p}, \quad p-i \leq n \leq p-1 \\ \theta(\rho_{i_1, \dots, i_n, 2p-i-1}) &= f_{n-p}^{(i_1, \dots, i_n)} \tilde{y}_{n-p}, \quad p \leq n \leq 2p-i-1 \end{aligned}$$

For $\tilde{x}_n \in \mathcal{P}_i^+$, we have $E\tilde{x}_n = -[n][p-i-n]\tilde{x}_{n-1}$, and hence:

$$E^n \tilde{x}_n = (-1)^n \frac{([n]!)([p-i-1]!)}{([p-i-n-1]!)} \tilde{x}_0$$

Then we have for $1 \leq n \leq p - i - 1$:

$$\begin{aligned}\theta(x_{0,2p-i-1}) &= c_0 \tilde{x}_0 \\ \theta(E^n \rho_{i_1, \dots, i_n, 2p-i-1}) &= q^{\binom{n(2p-i-1) - \frac{1}{2}(n^2-n) - (\sum_{j=1}^n i_j)}{[n]!}} ([n]!) c_0 \tilde{x}_0 \\ E^n \theta(\rho_{i_1, \dots, i_n, 2p-i-1}) &= (-1)^n \frac{([n]!)([p-i-1]!)}{([p-i-n-1]!)} c_n^{(i_1, \dots, i_n)} \tilde{x}_0 \\ \theta(\rho_{i_1, \dots, i_n, 2p-i-1}) &= q^{\binom{n(p-i-1) - \frac{1}{2}(n^2-n) - (\sum_{j=1}^n i_j)}{[p-i-1]!}} \frac{([p-i-n-1]!)}{([p-i-1]!)} c_0 \tilde{x}_n\end{aligned}$$

We have $E\tilde{a}_n = [n][i-n]\tilde{a}_{n-1}$, and $E\tilde{b}_n = [n][i-n]\tilde{b}_{n-1} + \tilde{a}_{n-1}$. Given $g_j \tilde{a}_j + h_j \tilde{b}_j \in \mathcal{P}_i^+$, $g_j h_j \in \mathbb{K}$, we then have:

$$\begin{aligned}E^k(g_j \tilde{a}_j + h_j \tilde{b}_j) &= g_{j-k} \tilde{a}_{j-k} + h_{j-k} \tilde{b}_{j-k} \\ g_{j-k} &= g_{j-k+1} [j-k+1][i-j+k-1] + h_{j-k+1} \\ h_{j-k} &= h_j \frac{([j]!)([i-j+k-1]!)}{([j-k]!)([i-j-1]!)} \\ E^j(g_j \tilde{a}_j + h_j \tilde{b}_j) &= h_j \frac{([j]!)([i-1]!)}{([i-j-1]!)} \tilde{x}_{i-1}\end{aligned}$$

Ignoring the coefficients for \tilde{a}_j , we have for $p-i \leq n \leq p-1$:

$$\begin{aligned}\theta(E^n \rho_{i_1, \dots, i_n, 2p-i-1}) &= q^{\binom{n(2p-i-1) - \frac{1}{2}(n^2-n) - (\sum_{j=1}^n i_j)}{[n]!}} ([n]!) c_0 \tilde{x}_0 \\ E^n \theta(\rho_{i_1, \dots, i_n, 2p-i-1}) &= (-1)^{p-i-1} \frac{([p-i-1]!)^2 ([n+i-p]!) ([i-1]!)}{([p-n-1]!)} e_{n+i-p}^{(i_1, \dots, i_n)} \tilde{x}_0 \\ \theta(\rho_{i_1, \dots, i_n, 2p-i-1}) &= d_{n+i-p}^{(i_1, \dots, i_n)} \tilde{a}_{n+i-p} + (-1)^{p-i-1} q^{\binom{n(2p-i-1) - \frac{1}{2}(n^2-n) - (\sum_{j=1}^n i_j)}{[p-n-1]!}} \times \\ &\quad \times \frac{([n]!)([p-n-1]!)}{([n+i-p]!)([p-i-1]!)^2 ([i-1]!)} c_0 \tilde{b}_{n+i-p}\end{aligned}$$

As $E^p = 0$, we have to proceed differently for \tilde{y}_n .

Given $\rho_{i_1, \dots, i_n, z} \in X_{n,z}$ we have:

$$F^{z-n}(\rho_{i_1, \dots, i_n, z}) = q^{\binom{nz - \frac{1}{2}(n^2-n) - (\sum_{j=1}^n i_j)}{[z-n]!}} ([z-n]!) x_{z,z}$$

Then for $p \leq n \leq 2p-i-1$ we have:

$$\begin{aligned}\theta(\rho_{i_1, \dots, i_n, 2p-i-1}) &= f_{n-p}^{(i_1, \dots, i_n)} \tilde{y}_{n-p} \\ \theta(F^{2p-i-1-n} \rho_{i_1, \dots, i_n, 2p-i-1}) &= q^{\binom{n(2p-i-1) - \frac{1}{2}(n^2-n) - (\sum_{j=1}^n i_j)}{[2p-i-1-n]!}} ([2p-i-1-n]!) f_{p-i-1} \tilde{y}_{i-1} \\ F^{2p-i-1-n} \theta(\rho_{i_1, \dots, i_n, 2p-i-1}) &= f_{n-p}^{(i_1, \dots, i_n)} \tilde{y}_{i-1} \\ \theta(\rho_{i_1, \dots, i_n, 2p-i-1}) &= q^{\binom{n(2p-i-1) - \frac{1}{2}(n^2-n) - (\sum_{j=1}^n i_j)}{[2p-i-1-n]!}} ([2p-i-1-n]!) f_{p-i-1} \tilde{y}_{n-p}\end{aligned}$$

However, $F(d_{i-1}^{(i_1, \dots, i_{p-1})} \tilde{a}_{i-1} + e_{i-1}^{(i_1, \dots, i_{p-1})} \tilde{b}_{i-1}) = e_{i-1}^{(i_1, \dots, i_{p-1})} \tilde{y}_0$.

Hence:

$$\theta(F^{p-i} \rho_{i_1, \dots, i_{p-1}, 2p-i-1}) = q \binom{(p-1)(2p-i) - \frac{1}{2}(p^2-p) - (\sum_{j=1}^{p-1} i_j)}{[p-i]!} f_{p-i-1} \tilde{y}_{p-i-1}$$

From previously, we have:

$$\begin{aligned} \theta(\rho_{i_1, \dots, i_{p-1}, 2p-i-1}) &= d_{i-1}^{(i_1, \dots, i_{p-1})} \tilde{a}_{i-1} + (-1)^{p-i-1} q \binom{(p-1)(2p-i-1) - \frac{1}{2}(p-1)(p-2) - (\sum_{j=1}^{p-1} i_j)}{[p-1]!} \times \\ &\quad \times \frac{([p-1]!)}{([i-1]!)^2 ([p-i-1]!)^2} c_0 \tilde{b}_{i-1} \\ F^{p-i} \theta(\rho_{i_1, \dots, i_{p-1}, 2p-i-1}) &= q \binom{(p-1)(2p-i) - \frac{1}{2}(p^2-p) - (\sum_{j=1}^{p-1} i_j)}{[p-i-1]!} \frac{(-1)^{p-i-1} ([p-1]!)}{([p-i-1]!)^2 ([i-1]!)^2} c_0 \tilde{y}_{i-1} \\ f_{p-i-1} &= (-1)^{p-i-1} \frac{([p-1]!)}{([p-i-1]!)^2 ([i-1]!)^2 ([p-i]!)} c_0 \end{aligned}$$

Putting this all together, we have the general formula for the map $\theta^{\otimes 2p-i-1} \rightarrow \mathcal{P}_i^+$ is:

$$\begin{aligned} \theta(\rho_{i_1, \dots, i_n, 2p-i-1}) &= q \binom{n(p-i-1) - \frac{1}{2}(n^2-n) - (\sum_{j=1}^n i_j)}{[p-i-n-1]!} \frac{([p-i-n-1]!)}{([p-i-1]!)} c_0 \tilde{x}_n, \quad 0 \leq n \leq p-i-1 \\ \theta(\rho_{i_1, \dots, i_n, 2p-i-1}) &= q \binom{n(2p-i-1) - \frac{1}{2}(n^2-n) - (\sum_{j=1}^n i_j)}{[n+i-p]!} \frac{(-1)^{p-i-1} ([n]!) ([p-n-1]!)}{([p-i-1]!)^2 ([i-1]!)} c_0 \tilde{b}_{n+i-p} \\ &\quad + d_{n+i-p}^{(i_1, \dots, i_n)} \tilde{a}_{n+i-p}, \quad p-i \leq n \leq p-1 \\ \theta(\rho_{i_1, \dots, i_n, 2p-i-1}) &= q \binom{n(2p-i-1) - \frac{1}{2}(n^2-n) - (\sum_{j=1}^n i_j)}{[p-i-1]!} \frac{(-1)^{p-i-1} ([p-1]!) ([2p-i-1-n]!)}{([p-i-1]!)^2 ([i-1]!)^2 ([p-i]!)} c_0 \tilde{y}_{n-p}, \\ &\quad p \leq n \leq 2p-i-1 \end{aligned}$$

6.2.2 General Formula for the map $\Gamma : \mathcal{P}_i^+ \rightarrow X^{\otimes 2p-i-1}$

Again by comparing weight spaces, we have that Γ must be of the form:

$$\begin{aligned} \Gamma(\tilde{x}_n) &\in X_{n, 2p-i-1}, \quad 0 \leq n \leq p-i-1 \\ \Gamma(\tilde{a}_n) &\in X_{n+p-i, 2p-i-1}, \quad 0 \leq n \leq i-1 \\ \Gamma(\tilde{b}_n) &\in X_{n+p-i, 2p-i-1}, \quad 0 \leq n \leq i-1 \\ \Gamma(\tilde{y}_n) &\in X_{n+p, 2p-i-1}, \quad 0 \leq n \leq p-i-1 \end{aligned}$$

Let $\Gamma(\tilde{x}_0) = g_0 x_{0, p+i-1}$, $g_0 \in \mathbb{K}$. As $F^n \tilde{x}_0 = \tilde{x}_n$, $0 \leq n \leq p-i-1$, $F \tilde{x}_{p-i-1} = \tilde{a}_0$, $F^k \tilde{a}_0 = \tilde{a}_k$, $0 \leq k \leq i-1$, then we have:

$$\begin{aligned} \Gamma(\tilde{x}_n) &= g_0 F^n x_{0, 2p-i-1} \quad 0 \leq n \leq p-i-1 \\ \Gamma(\tilde{a}_n) &= g_0 F^{n+p-i} x_{0, 2p-i-1} \quad 0 \leq n \leq i-1 \end{aligned}$$

Given $\tilde{y}_j \in \mathcal{P}_i^+$, and $E\tilde{y}_j = -[j][p-i-j]\tilde{y}_{j-1}$, $E\tilde{y}_0 = \tilde{a}_{i-1}$, we have:

$$E^k \tilde{y}_j = (-1)^k \frac{([j]!)([p-i-j+k-1]!)}{([j-k]!)([p-i-j-1]!)} \tilde{y}_{j-k}$$

Let $\Gamma(\tilde{y}_{p-i-1}) = h_{p-i-1}x_{2p-i-1, 2p-i-1}$. Then we have:

$$\begin{aligned} \Gamma(\tilde{y}_{p-i-1-k}) &= (-1)^k \frac{([p-i-1-k]!)}{([p-i-1]!)([k]!)} h_{p-i-1} E^k x_{2p-i-1, 2p-i-1} \\ \Gamma(\tilde{y}_n) &= \frac{(-1)^{p-i-1-n}([n]!)}{([p-i-1]!)([p-i-1-n]!)} h_{p-i-1} E^{p-i-1-n} x_{2p-i-1, 2p-i-1}, \\ &0 \leq n \leq p-i-1 \\ \Gamma(\tilde{a}_{i-1}) &= (-1)^{p-i-1} \frac{1}{([p-i-1]!)^2} h_{p-i-1} E^{p-i} x_{2p-i-1, 2p-i-1} \end{aligned}$$

Note that both $F^{p-1}x_{0, 2p-i-1}$ and $E^{p-i}x_{2p-i-1, 2p-i-1}$ lie in $X_{p-1, 2p-i-1}$, however comparing coefficients we have:

$$\begin{aligned} F^{p-1}x_{0, 2p-i-1} &= \sum_{1 \leq i_j \leq 2p-i-1} q^{\left(\frac{1}{2}(p^2-p) - \left(\sum_{j=1}^{p-1} i_j\right)\right)} ([p-1]!) \rho_{i_1, \dots, i_{p-1}, 2p-i-1} \\ E^{p-i}x_{2p-i-1, 2p-i-1} &= \sum_{1 \leq i_j \leq 2p-i-1} q^{\left(\frac{1}{2}(p^2-p) - \left(\sum_{j=1}^{p-1} i_j\right)\right)} ([p-i]!) \rho_{i_1, \dots, i_{p-1}, 2p-i-1} \\ E^{p-i}x_{2p-i-1, 2p-i-1} &= \frac{([p-i]!)}{([p-1]!)} F^{p-1}x_{0, 2p-i-1} \end{aligned}$$

Hence:

$$\begin{aligned} ([p-1]!)g_0 &= (-1)^{p-i-1} \frac{([p-i]!)}{([p-i-1]!)^2} h_{p-i-1} \\ h_{p-i-1} &= (-1)^{p-i-1} \frac{([p-1]!)([p-i-1]!)^2}{([p-i]!)} g_0 \end{aligned}$$

$$\text{Let } \Gamma(\tilde{b}_n) = \sum_{1 \leq i_j \leq 2p-i-1} m_n^{(i_1, \dots, i_{n+p-i})} \rho_{i_1, \dots, i_{n+p-i}, 2p-i-1}.$$

Putting these together, we have the general form for $\Gamma : \mathcal{P}_i^+ \rightarrow X^{\otimes 2p-i-1}$ is:

$$\begin{aligned} \Gamma(\tilde{x}_n) &= g_0 F^n x_{0, 2p-i-1}, \quad 0 \leq n \leq p-i-1 \\ \Gamma(\tilde{a}_n) &= g_0 F^{n+p-i} x_{0, 2p-i-1}, \quad 0 \leq n \leq i-1 \\ \Gamma(\tilde{b}_n) &= \sum_{1 \leq i_j \leq 2p-i-1} m_n^{(i_1, \dots, i_{n+p-i})} \rho_{i_1, \dots, i_{n+p-i}, 2p-i-1}, \quad 0 \leq n \leq i-1 \\ \Gamma(\tilde{y}_n) &= (-1)^n \frac{([n]!)([p-1]!)([p-i-1]!)}{([p-i]!)([p-i-1-n]!)} g_0 E^{p-i-1-n} x_{2p-i-1, 2p-i-1}, \\ &0 \leq n \leq p-i-1 \end{aligned}$$

6.2.3 General Formula for the Second Endomorphism on \mathcal{P}_i^+ .

We can combine our general formula for θ and Γ to find the general form of

$\Gamma\theta : X^{\otimes 2p-i-1} \rightarrow \mathcal{P}_i^+ \rightarrow X^{\otimes 2p-i-1}$ is:

$$\theta(\rho_{i_1, \dots, i_n, 2p-i-1}) = q^{\binom{n(p-i-1) - \frac{1}{2}(n^2-n) - (\sum_{j=1}^n i_j)}{[p-i-n-1]!}} \frac{([p-i-n-1]!)}{([p-i-1]!)} c_0 g_0 F^n x_{0, 2p-i-1},$$

$$0 \leq n \leq p-i-1$$

$$\theta(\rho_{i_1, \dots, i_n, 2p-i-1}) = d_{n+i-p}^{(i_1, \dots, i_n)} g_0 F^n x_{0, 2p-i-1} +$$

$$\sum_{1 \leq j_k \leq 2p-i-1} \left((-1)^{p-i-1} q^{\binom{n(2p-i-1) - \frac{1}{2}(n^2-n) - (\sum_{j=1}^n i_j)}{[p-n-1]!}} \times \right. \\ \left. \times \frac{([n]!)([p-n-1]!)}{([n+i-p]!)([p-i-1]!)^2([i-1]!)} c_0 m_n^{(j_1, \dots, j_n)} \rho_{j_1, \dots, j_n, 2p-i-1} \right),$$

$$p-i \leq n \leq p-1$$

$$\theta(\rho_{i_1, \dots, i_n, 2p-i-1}) = (-1)^{n-i-1} q^{\binom{n(2p-i-1) - \frac{1}{2}(n^2-n) - (\sum_{j=1}^n i_j)}{[p-i-1]!}} \frac{([n-p]!)([p-1]!)^2}{([p-i-1]!)([i-1]!)^2([p-i]!)^2} \times$$

$$\times c_0 g_0 E^{2p-i-1-n} x_{2p-i-1, 2p-i-1},$$

$$p \leq n \leq 2p-i-1$$

The second endomorphism ε on \mathcal{P}_i^+ is given by $\varepsilon(b_n) = a_n$, $0 \leq n \leq i-1$, $\varepsilon(x_m) = \varepsilon(a_n) = \varepsilon(y_m) = 0$, $0 \leq m \leq p-i-1$. Using this, along with the maps previously, we can have the map:

$$\theta \varepsilon \Gamma : X^{\otimes 2p-i-1} \rightarrow \mathcal{P}_i^+ \xrightarrow{\varepsilon} \mathcal{P}_i^+ \rightarrow X^{\otimes 2p-i-1}$$

This is given by:

$$\theta \varepsilon \Gamma(\rho_{i_1, \dots, i_n, 2p-i-1}) = (-1)^{p-i-1} q^{\binom{n(2p-i-1) - \frac{1}{2}(n^2-n) - (\sum_{j=1}^n i_j)}{[p-n-1]!}} \times \\ \times \frac{([n]!)([p-n-1]!)}{([n+i-p]!)([p-i-1]!)^2([i-1]!)} c_0 g_0 F^n x_{0, 2p-i-1},$$

$$p-i \leq n \leq p-1$$

$$\theta \varepsilon \Gamma(\rho_{i_1, \dots, i_n, 2p-i-1}) = 0, \quad n < p-i, \quad n > p-1$$

6.3 The Homomorphisms $\mathcal{P}_i^+ \rightarrow \mathcal{X}_i^+$.

We want to give a diagrammatic description of the map:

$$\theta : X^{\otimes 2p-i-1} \rightarrow \mathcal{P}_i^+ \rightarrow \mathcal{X}_i^+ \rightarrow X^{\otimes i-1}$$

Explicitly, using sections 4.4 and 6.2.1, this is a composition of the following maps:

$$\begin{aligned}
X^{\otimes 2p-i-1} &\rightarrow \mathcal{P}_i^+ : \rho_{i_1, \dots, i_n, 2p-i-1} \mapsto (-1)^{p-i-1} q^{\binom{n(2p-i-1) - \frac{1}{2}(n^2-n) - (\sum_{j=1}^n i_j)}{2}} \times \\
&\quad \times \frac{([n]!)([p-n-1]!)}{([n+i-p]!)([i-1]!)([p-i-1]!)^2} b_{n+i-p}, \quad p-i \leq n \leq p-1 \\
\mathcal{P}_i^+ &\rightarrow \mathcal{X}_i^+ : x_j \mapsto 0 \\
&\quad : a_k \mapsto 0 \\
&\quad : b_k \mapsto z_k, \quad 0 \leq k \leq i-1 \\
&\quad : y_j \mapsto 0 \\
\mathcal{X}_i^+ &\rightarrow X^{\otimes i-1} : z_k \mapsto F^k x_{0, i-1}
\end{aligned}$$

Combining them, we get:

$$\begin{aligned}
\theta(\rho_{i_1, \dots, i_n, 2p-i-1}) &= (-1)^{p-i-1} q^{\binom{n(2p-i-1) - \frac{1}{2}(n^2-n) - (\sum_{j=1}^n i_j)}{2}} \times \\
&\quad \times \frac{([n]!)([p-n-1]!)}{([n+i-p]!)([i-1]!)([p-i-1]!)^2} F^{n+i-p} x_{0, i-1} \\
&\quad p-i \leq n \leq p-1 \\
\theta(\rho_{i_1, \dots, i_n, 2p-i-1}) &= 0, \quad 0 \leq n < p-i, \quad p-1 < n \leq 2p-i-1
\end{aligned}$$

We want to show that, up to a constant, this is given diagrammatically by:

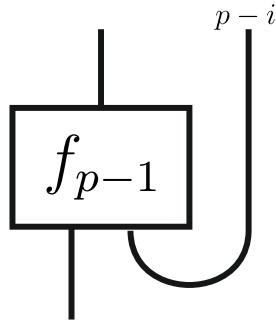

Proof. Given an element $\rho_{i_1, \dots, i_r, p-1}$, we can rewrite it as:

$$\rho_{i_1, \dots, i_r, p-1} \otimes \rho_{(i_{r+1}+1-p), \dots, (i_n+1-p), p-i} \in X_{n, 2p-i-1}$$

Acting $\mathfrak{f}_{p-1} \otimes 1^{\otimes p-i}$ on this we get:

$$\begin{aligned}
& q^{\binom{r(p-1)-\frac{1}{2}(r^2-r)-(\sum_{j=1}^r i_j)}{[p-1]!}} \frac{([p-1-r]!)}{([p-1]!)} (F^r x_{0,p-1}) \otimes \rho_{(i_{r+1}+1-p), \dots, (i_n+1-p), p-i} \\
&= \sum_{m=0}^r q^{\binom{r(p-1)-\frac{1}{2}(r^2-r)-(\sum_{j=1}^r i_j)}{[p-1]!}} \frac{([p-1-r]!)}{([p-1]!)} \lambda_{m,r} \times \\
&\quad \times (K^{-m} F^{r-m} x_{0,i-1}) \otimes (F^m x_{0,p-i}) \otimes \rho_{(i_{r+1}+1-p), \dots, (i_n+1-p), p-i} \\
&= \sum_{m=0}^r q^{\binom{r(p-1)-\frac{1}{2}(r^2-r)+2m(r-m)-m(i-1)-(\sum_{j=1}^r i_j)}{[p-1]!}} \frac{([p-1-r]!)}{([p-1]!)} \lambda_{m,r} \times \\
&\quad \times (F^{r-m} x_{0,i-1}) \otimes (F^m x_{0,p-i}) \otimes \rho_{(i_{r+1}+1-p), \dots, (i_n+1-p), p-i}
\end{aligned}$$

We now want to apply $(p-i)$ copies of \cup to this. Note that from section 5.1, we have $\cup(\nu_{00}) = \cup(\nu_{11}) = 0$, $\cup(\nu_{10}) = 1$, $\cup(\nu_{01}) = -q$. This means that the number of zeros in $(F^m x_{0,p-i})$ must be equal to the number of ones in $\rho_{(i_{r+1}+1-p), \dots, (i_n+1-p), p-i}$. Hence we need $p-i-m = n-r$, and so $m = p-i-n+r$. This then gives:

$$\begin{aligned}
& q^{\binom{r(p-1)-\frac{1}{2}(r^2-r)+(p-i-n+r)(2n+i-2p+1)-(\sum_{j=1}^r i_j)}{[p-1]!}} \frac{([p-1-r]!)}{([p-1]!)} \lambda_{p-i-n+r,r} \times \\
&\quad \times (F^{n+i-p} x_{0,i-1}) \otimes (F^{p-i-n+r} x_{0,p-i}) \otimes \rho_{(i_{r+1}+1-p), \dots, (i_n+1-p), p-i} \\
&= \sum_{1 \leq k_l \leq p-i} \frac{([p-1-r]!)([p-i-n+r]!)}{([p-1]!)} \lambda_{p-i-n+r,r} \times \\
&\quad \times q^{\binom{r(p-1)-\frac{1}{2}(r^2-r)+(p-i-n+r)(2n+i-2p+1)+\frac{1}{2}(p-i-n+r)(p-i-n+r+1)-(\sum_{j=1}^r i_j)-(\sum_{l=1}^{p-i-n+r} k_l)}{[p-1]!}} \times \\
&\quad \times (F^{n+i-p} x_{0,i-1}) \otimes \rho_{k_1, \dots, k_{p-i-n+r}, p-i} \otimes \rho_{(i_{r+1}+1-p), \dots, (i_n+1-p), p-i}
\end{aligned}$$

Denote the positions of the zeros in $\rho_{k_1, \dots, k_{p-i-n+r}, p-i}$ by $\tilde{k}_1, \dots, \tilde{k}_{n-r}$. To apply $\cup(p-i)$ times to $\rho_{k_1, \dots, k_{p-i-n+r}, p-i} \otimes \rho_{(i_{r+1}+1-p), \dots, (i_n+1-p), p-i}$, we need that

$$(p-i+1-\tilde{k}_{n-r}), \dots, (p-i+1-\tilde{k}_1) = (i_{r+1}+1-p), \dots, (i_n+1-p), \text{ and so}$$

$$(n-r)(1-p) + \sum_{j=r+1}^n i_j = (n-r)(p-i+1) - \left(\sum_{l=1}^{n-r} \tilde{k}_l\right). \text{ However, we also have}$$

$$\sum_{l=1}^{p-i-n+r} k_l + \sum_{m=1}^{n-r} \tilde{k}_m = \sum_{k=1}^{p-i} k = \frac{1}{2}(p-i)(p-i+1). \text{ Hence we have}$$

$$\sum_{l=1}^{p-i-n+r} k_l = \frac{1}{2}(p-i)(p-i+1) + (n-r)(i-2p) + \sum_{j=r+1}^n i_j.$$

We can now apply \cup ($p - i$) times to get:

$$\begin{aligned}
& (-1)^{n-r} q^{\binom{r(p-1)+n-r-\frac{1}{2}(r^2-r)+\frac{1}{2}(p-i-n+r)(3n+i-3p+r+3)-(\sum_{j=1}^r i_j)-(\sum_{l=1}^{p-i-n+r} k_l)} \times \\
& \times \frac{([p-1-r]!)([p-i-n+r]!)}{([p-1]!)} \lambda_{p-i-n+r,r} F^{n+i-p} x_{0,i-1} \\
= & q^{\binom{r(p-1)-\frac{1}{2}(r^2-r)+\frac{1}{2}(p-i-n+r)(3n+i-3p+r+3)-\frac{1}{2}(p-i)(p-i+1)-(n-r)(i-1-2p)-(\sum_{j=1}^r i_j)-(\sum_{j=r+1}^n i_j)} \times \\
& \times (-1)^{n-r} \frac{([p-1-r]!)([p-i-n+r]!)}{([p-1]!)} \lambda_{p-i-n+r,r} F^{n+i-p} x_{0,i-1} \\
= & q^{\binom{r(p-1)-\frac{1}{2}(r^2-r)+\frac{1}{2}(p-i-n+r)(3n+i-3p+r+3)-\frac{1}{2}(p-i)(p-i+1)} \times \\
& \times q^{\binom{-(n-r)(i-1-2p)+(p-i-n+r)^2-r(p-i-n+r)-(\sum_{j=1}^n i_j)} \times \\
& (-1)^{n-r} \times \frac{([p-1-r]!)([p-i-n+r]!)([r]!)}{([p-1]!)([p-i-n+r]!)([n+i-p]!)} F^{n+i-p} x_{0,i-1} \\
= & q^{\binom{r(p-1)-\frac{1}{2}(r^2-r)+\frac{1}{2}(p-i-n+r)(3n+i-3p+r+3)-\frac{1}{2}(p-i)(p-i+1)} \times \\
& \times q^{\binom{-(n-r)(i-1-2p)+(p-i-n+r)^2-r(p-i-n+r)-(\sum_{j=1}^n i_j)} \times \\
& \times (-1)^{n-r} \frac{([p-1-r]!)([r]!)}{([p-1]!)([n+i-p]!)} F^{n+i-p} x_{0,i-1} \\
= & q^{\binom{n(2p-i-1)-\frac{1}{2}(n^2-n)+i(p-1)-p(p-n-1+r)-(\sum_{j=1}^n i_j)} \frac{(-1)^{n-r}([p-1-r]!)([r]!)}{([p-1]!)([n+i-p]!)} F^{n+i-p} x_{0,i-1} \\
= & (-1)^{p-i-1} q^{\binom{n(2p-i-1)-\frac{1}{2}(n^2-n)-i-(\sum_{j=1}^n i_j)} \frac{([p-1-r]!)([r]!)}{([p-1]!)([n+i-p]!)} F^{n+i-p} x_{0,i-1}
\end{aligned}$$

Note that as $[p-j] = [j]$, we have $([r]!)([p-r-1]!) = [p-1]! = ([n]!)([p-n-1]!)$. Hence this is equal to:

$$-q^{-i} \frac{([p-i-1]!)}{[i]} \theta(\rho_{i_1, \dots, i_n, 2p-i-1})$$

Note that we included an extra minus sign to account for our choice of \cup . \square

6.4 The Homomorphisms $\mathcal{X}_i^+ \rightarrow \mathcal{P}_i^+$.

We want to give a diagrammatic description of the map:

$$\Gamma : X^{\otimes i-1} \rightarrow \mathcal{X}_i^+ \rightarrow \mathcal{P}_i^+ \rightarrow X^{\otimes 2p-i-1}$$

Explicitly, using sections 4.4 and 6.2.2, this is a composition of the following maps:

$$X^{\otimes i-1} \rightarrow \mathcal{X}_i^+ : \rho_{i_1, \dots, i_n, i-1} \mapsto q^{\binom{n(i-1)-\frac{1}{2}(n^2-n)-(\sum_{j=1}^n i_j)} \frac{([i-1-n]!)}{([i-1]!)} z_n, \quad 0 \leq n \leq i-1$$

$$\mathcal{X}_i^+ \rightarrow \mathcal{P}_i^+ : z_n \mapsto a_n$$

$$\mathcal{P}_i^+ \rightarrow X^{\otimes 2p-i-1} : a_n \mapsto F^{n+p-i} x_{0,2p-i-1}$$

Taking their composition we get:

$$\Gamma(\rho_{i_1, \dots, i_n, i-1}) = q^{\binom{n(i-1) - \frac{1}{2}(n^2 - n) - (\sum_{j=1}^n i_j)}{[i-1]!}} F^{n+p-i} x_{0, 2p-i-1} \quad 0 \leq n \leq i-1$$

We want to show that diagrammatically, up to a constant, this is given by:

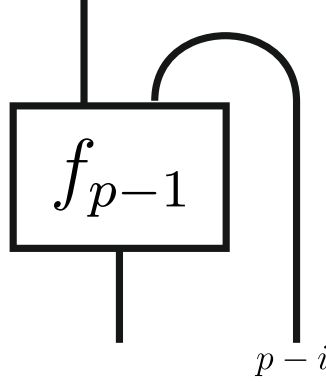

Proof. Given $\rho_{j_1, \dots, j_k, z}$, let $\tilde{j}_1, \dots, \tilde{j}_{z-k}$ be the positions of the zeros. As $\cap(\nu) = q^{-1}\nu_{10} - \nu_{01}$, we have that the z -fold cap is given by:

$$\sum_{k=0}^z \left(\sum_{1 \leq j_l \leq z} (-1)^{z-k} q^{-k} \rho_{j_1, \dots, j_k, (2z+1-\tilde{j}_{z-k}), \dots, (2z+1-\tilde{j}_1), 2z} \right)$$

Hence given $\rho_{i_1, \dots, i_n, i-1}$, we want to consider the action of $(f_{p-1} \otimes 1^{\otimes p-i})$ on the following:

$$\sum_{k=0}^{p-i} \left(\sum_{1 \leq j_l \leq p-i} (-1)^{p-i-k} q^{-k} \rho_{i_1, \dots, i_n, i-1} \otimes \rho_{j_1, \dots, j_k, (2p-2i+1-\tilde{j}_{p-i-k}), \dots, (2p-2i+1-\tilde{j}_1), 2p-2i} \right)$$

This is given by:

$$\begin{aligned} & \sum_{k=0}^{p-i} \left(\sum_{1 \leq j_l \leq p-i} (-1)^{p-i-k} q^{-k} q^{\binom{(n+k)(p-1) - \frac{1}{2}(n+k)(n+k-1) - k(i-1) - (\sum_{j=1}^n i_j) - (\sum_{l=1}^k j_l)}{[p-1]!}} \times \right. \\ & \quad \left. \times \frac{([p-1-n-k]!)}{([p-1]!)} (F^{n+k} x_{0, p-1}) \otimes \rho_{(p-i+1-\tilde{j}_{p-i-k}), \dots, (p-i+1-\tilde{j}_1), p-i} \right) \\ &= \sum_{k=0}^{p-i} \left(\sum_{1 \leq j_l \leq p-i} (-1)^{p-i-k} q^{\binom{(n+k)(p-1) - \frac{1}{2}(n+k)(n+k-1) - ki - (\sum_{j=1}^n i_j) - (\sum_{l=1}^k j_l)}{[p-1]!}} \times \right. \\ & \quad \left. \times \frac{([p-1-n-k]!)}{([p-1]!)} (F^{n+k} x_{0, p-1}) \otimes \rho_{(p-i+1-\tilde{j}_{p-i-k}), \dots, (p-i+1-\tilde{j}_1), p-i} \right) \end{aligned}$$

Note that as $\sum_{l=1}^k j_l + \sum_{m=1}^{p-i-k} \tilde{j}_m = \frac{1}{2}(p-i)(p-i+1)$, we have:

$$\begin{aligned}
& \sum_{k=0}^{p-i} \left(\sum_{1 \leq j_l \leq p-i} (-1)^{p-i-k} q^{\binom{(n+k)(p-1) - \frac{1}{2}(n+k)(n+k-1) - ki - (\sum_{j=1}^n i_j) - \frac{1}{2}(p-i)(p-i+1) + (\sum_{l=1}^{p-i-k} \tilde{j}_l)}{}} \right) \times \\
& \quad \times \frac{([p-1-n-k]!)}{([p-1]!)} (F^{n+k} x_{0,p-1}) \otimes \rho_{(p-i+1-\tilde{j}_{p-i-k}), \dots, (p-i+1-\tilde{j}_1), p-i} \\
& = \sum_{k=0}^{p-i} \left(\sum_{1 \leq m_r \leq p-1} \sum_{1 \leq j_l \leq p-i} q^{\binom{(n+k)(p-1) - \frac{1}{2}(n+k)(n+k-1) - ki - (\sum_{j=1}^n i_j) - \frac{1}{2}(p-i)(p-i+1)}{}} \right) \times \\
& \quad \times q^{\binom{(\sum_{l=1}^{p-i-k} \tilde{j}_l) + \frac{1}{2}(n+k)(n+k+1) - (\sum_{r=1}^{n+k} m_r)}{}} (-1)^{p-i-k} \times \\
& \quad \frac{([p-1-n-k]!)([n+k]!)}{([p-1]!)} \rho_{m_1, \dots, m_{n+k}, p-1} \otimes \rho_{(p-i+1-\tilde{j}_{p-i-k}), \dots, (p-i+1-\tilde{j}_1), p-i} \\
& = \sum_{k=0}^{p-i} \left(\sum_{1 \leq m_r \leq p-1} \sum_{1 \leq j_l \leq p-i} q^{\binom{p(n+k) - ki - (\sum_{j=1}^n i_j) - \frac{1}{2}(p-i)(p-i+1) + (\sum_{l=1}^{p-i-k} \tilde{j}_l) - (\sum_{r=1}^{n+k} m_r)}{}} \right) \times \\
& \quad \times (-1)^{p-i-k} \frac{([p-1-n-k]!)([n+k]!)}{([p-1]!)} \rho_{m_1, \dots, m_{n+k}, (2p-i-\tilde{j}_{p-i-k}), \dots, (2p-i-\tilde{j}_1), 2p-i-1}
\end{aligned}$$

Let $r_1 := 2p-i-\tilde{j}_{p-i-k}, \dots, r_{p-i-k} := 2p-i-\tilde{j}_1$, then

$\sum_{l=1}^{p-i-k} r_l = (p-i-k)(2p-i) - (\sum_{m=1}^{p-i-k} \tilde{j}_m)$, and we can rewrite as:

$$\begin{aligned}
& \sum_{k=0}^{p-i} \left(\sum_{1 \leq m_j \leq p-1} \sum_{p \leq r_l \leq 2p-i-1} q^{\binom{p(n+k) - ki - (\sum_{j=1}^n i_j) - \frac{1}{2}(p-i)(p-i+1) + (p-i-k)(2p-i) - (\sum_{j=1}^{n+k} m_j)}{}} \right) \times \\
& \quad \times q^{\binom{-(\sum_{l=1}^{p-i-k} r_l)}{}} (-1)^{p-i-k} \frac{([p-1-n-k]!)([n+k]!)}{([p-1]!)} \rho_{m_1, \dots, m_{n+k}, r_1, \dots, r_{p-i-k}, 2p-i-1} \\
& = \sum_{k=0}^{p-i} \left(\sum_{1 \leq m_j \leq p-1} \sum_{p \leq r_l \leq 2p-i-1} q^{\binom{np - (\sum_{j=1}^n i_j) - \frac{1}{2}(p-i)(p-i+1) + (p-i)(2p-i) - (\sum_{j=1}^{n+k} m_j) - (\sum_{l=1}^{p-i-k} r_l)}{}} \right) \times \\
& \quad \times (-1)^{p-i} \rho_{m_1, \dots, m_{n+k}, r_1, \dots, r_{p-i-k}, 2p-i-1}
\end{aligned}$$

Relabelling $m_{n+k+l} := r_l$, $1 \leq l \leq p-i-k$, this becomes:

$$\begin{aligned}
& = \sum_{1 \leq m_j \leq 2p-i-1} (-1)^{p-i} q^{\binom{np - (\sum_{j=1}^n i_j) - \frac{1}{2}(p-i)(p-i+1) + (p-i)(2p-i) - (\sum_{j=1}^{n+p-i} m_j)}{}} \rho_{m_1, \dots, m_{n+p-i}, 2p-i-1} \\
& = \sum_{1 \leq m_j \leq 2p-i-1} \frac{(-1)^{p-i}}{([n+p-i]!)} q^{\binom{p(p-1)+i(n-p+1) - \frac{1}{2}(n^2+n) - (\sum_{j=1}^n i_j)}{}} \times \\
& \quad \times q^{\binom{\frac{1}{2}(n+p-i)(n+p-i+1) - (\sum_{j=1}^{n+p-i} m_j)}{}} ([n+p-i]!) \rho_{m_1, \dots, m_{n+p-i}, 2p-i-1} \\
& = q^{\binom{i(n+1) - p - \frac{1}{2}(n^2+n) - (\sum_{j=1}^n i_j)}{}} \frac{1}{([n+p-i]!)} F^{n+p-i} x_{0, 2p-i-1} \\
& = q^i \frac{([i-1]!)}{([p-1]!)} \Gamma(\rho_{i_1, \dots, i_n, i-1})
\end{aligned}$$

where again we included an extra minus sign to account for our choice of \cap . \square

6.5 The Second Endomorphisms $\mathcal{P}_i^+ \xrightarrow{\varepsilon} \mathcal{P}_i^+$.

We want to give a diagrammatic description of the map:

$$\Phi : X^{\otimes 2p-i-1} \rightarrow \mathcal{P}_i^+ \xrightarrow{\varepsilon} \mathcal{P}_i^+ \rightarrow X^{\otimes 2p-i-1}$$

Explicitly, using sections 4.4, 6.2.1, and 6.2.2, this is the composition of the following maps:

$$\begin{aligned} X^{\otimes 2p-i-1} \rightarrow \mathcal{P}_i^+ : \rho_{i_1, \dots, i_n, 2p-i-1} &\mapsto (-1)^{p-i-1} q^{\left(n(2p-i-1) - \frac{1}{2}(n^2-n) - \left(\sum_{j=1}^n i_j\right)\right)} \times \\ &\times \frac{([n]!)([p-n-1]!)}{([n+i-p]!)([i-1]!)([p-i-1]!)^2} b_{n+i-p} \\ p-i \leq n \leq p-1 \end{aligned}$$

$$\mathcal{P}_i^+ \xrightarrow{\varepsilon} \mathcal{P}_i^+ : b_k \mapsto a_k, \quad 0 \leq k \leq i-1$$

$$x_m \mapsto 0, \quad 0 \leq m \leq p-i-1$$

$$y_m \mapsto 0$$

$$a_k \mapsto 0$$

$$\mathcal{P}_i^+ \rightarrow X^{\otimes 2p-i-1} : a_k \mapsto F^{k+p-i} x_{0, 2p-i-1}$$

Combining them, we get:

$$\Phi(\rho_{i_1, \dots, i_n, 2p-i-1}) = q^{\left(n(2p-i-1) - \frac{1}{2}(n^2-n) - \left(\sum_{j=1}^n i_j\right)\right)} \frac{(-1)^{p-i-1} [i]}{([n+i-p]!)([p-i-1]!)} F^n x_{0, 2p-i-1}$$

$$p-i \leq n \leq p-1$$

$$\Phi(\rho_{i_1, \dots, i_n, 2p-i-1}) = 0, \quad n < p-i, \quad n > p-1$$

We want to show that, up to a constant, this is given diagrammatically by:

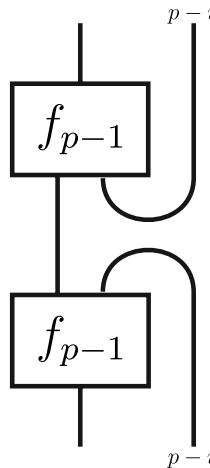

Proof. We prove this by showing that Φ is equal to the composition of the maps given in

sections 6.3 and 6.4, i.e:

$$\Phi = \Gamma\theta : X^{\otimes 2p-i-1} \rightarrow \mathcal{P}_i^+ \rightarrow \mathcal{X}_i^+ \rightarrow X^{\otimes i-1} \rightarrow \mathcal{X}_i^+ \rightarrow \mathcal{P}_i^+ \rightarrow X^{\otimes 2p-i-1}$$

We have:

$$\begin{aligned} \theta(\rho_{i_1, \dots, i_n, 2p-i-1}) &= (-1)^{p-i-1} q^{\binom{n(2p-i-1) - \frac{1}{2}(n^2-n) - (\sum_{j=1}^n i_j)}{}} \times \\ &\quad \times \frac{([n]!)([p-n-1]!)}{([n+i-p]!)([i-1]!)([p-i-1]!)^2} F^{n+i-p} x_{0, i-1}, \\ &\quad p-i \leq n \leq p-1 \\ \Gamma(\rho_{i_1, \dots, i_k, i-1}) &= q^{\binom{k(i-1) - \frac{1}{2}(k^2-k) - (\sum_{j=1}^k i_j)}{}} \frac{([i-1-k]!)}{([i-1]!)} F^{k+p-i} x_{0, 2p-i-1}, \quad 0 \leq k \leq i-1 \end{aligned}$$

To take their composition we first need to rewrite θ :

$$\begin{aligned} \theta(\rho_{i_1, \dots, i_n, 2p-i-1}) &= (-1)^{p-i-1} q^{\binom{n(2p-i-1) - \frac{1}{2}(n^2-n) - (\sum_{j=1}^n i_j)}{}} \times \\ &\quad \times \frac{([n]!)([p-n-1]!)}{([n+i-p]!)([i-1]!)([p-i-1]!)^2} F^{n+i-p} x_{0, i-1} \\ &= \sum_{1 \leq j_k \leq i-1} q^{\binom{n(2p-i-1) - \frac{1}{2}(n^2-n) - (\sum_{j=1}^n i_j) + \frac{1}{2}(n+i-p)(n+i-p+1) - (\sum_{k=1}^{n+i-p} j_k)}{}} \times \\ &\quad \times (-1)^{p-i-1} \frac{([n]!)([p-n-1]!)([n+i-p]!)}{([n+i-p]!)([i-1]!)([p-i-1]!)^2} \rho_{j_1, \dots, j_{n+i-p}, i-1} \\ &= \sum_{1 \leq j_k \leq i-1} q^{\binom{n(2p-i-1) - \frac{1}{2}(n^2-n) + \frac{1}{2}(n+i-p)(n+i-p+1) - (\sum_{j=1}^n i_j) - (\sum_{k=1}^{n+i-p} j_k)}{}} \times \\ &\quad \times (-1)^{p-i-1} \frac{([n]!)([p-n-1]!)}{([i-1]!)([p-i-1]!)^2} \rho_{j_1, \dots, j_{n+i-p}, i-1} \end{aligned}$$

Applying Γ to this we get:

$$\begin{aligned} \Gamma\theta(\rho_{i_1, \dots, i_n, 2p-i-1}) &= \sum_{1 \leq j_k \leq i-1} q^{\binom{n(2p-i-1) - \frac{1}{2}(n^2-n) + \frac{1}{2}(n+i-p)(n+i-p+1) - (\sum_{j=1}^n i_j) - (\sum_{k=1}^{n+i-p} j_k)}{}} \times \\ &\quad \times q^{\binom{(n+i-p)(i-1) - \frac{1}{2}(n+i-p)(n+i-p-1) - (\sum_{l=1}^{n+i-p} j_k)}{}} (-1)^{p-i-1} \times \\ &\quad \times \frac{([n]!)([p-n-1]!)([p-1-n]!)}{([p-i-1]!)^2([i-1]!)^2} F^n x_{0, 2p-i-1} \\ &= \sum_{1 \leq j_k \leq i-1} (-1)^{p-i-1} q^{\binom{n(2p-1) + i(i-p) - \frac{1}{2}(n^2-n) - (\sum_{j=1}^n i_j) - 2(\sum_{k=1}^{n+i-p} j_k)}{}} \times \\ &\quad \times \frac{[i]^2([p-1-n]!)}{([p-1]!)} F^n x_{0, 2p-i-1} \\ &= \left(\sum_{1 \leq j_k \leq i-1} q^{-2(\sum_{k=1}^{n+i-p} j_k)} \right) (-1)^{p-i-1} q^{\binom{n(2p-1) + i(i-p) - \frac{1}{2}(n^2-n) - (\sum_{j=1}^n i_j)}{}} \times \\ &\quad \times \frac{[i]^2([p-1-n]!)}{([p-1]!)} F^n x_{0, 2p-i-1} \end{aligned}$$

We now need to use equation A.22:

$$\sum_{1 \leq i_j \leq z} q^{-2(\sum_{j=1}^n i_j)} = q^{-n-nz} \frac{([z]!)}{([n]!)([z-n]!)}$$

Hence $\sum_{1 \leq j_k \leq i-1} q^{-2(\sum_{k=1}^{n+i-p} j_k)} = q^{i(p-i-n)} \frac{([i-1]!)}{([n+i-p]!)([p-1-n]!)}$. Therefore we have:

$$\begin{aligned} & (-1)^{p-i-1} q^{\left(n(2p-1)+i(i-p)+i(p-i-n)-\frac{1}{2}(n^2-n)-(\sum_{j=1}^n i_j)\right)} \times \\ & \times \frac{[i]^2([p-1-n]!)([i-1]!)}{([p-1]!)([n+i-p]!)([p-1-n]!)} F^n x_{0,2p-i-1} \\ & = (-1)^{p-i-1} q^{\left(n(2p-i-1)-\frac{1}{2}(n^2-n)-(\sum_{j=1}^n i_j)\right)} \frac{[i]([i]!)}{([p-1]!)([n+i-p]!)} F^n x_{0,2p-i-1} \\ & = (-1)^{p-i-1} q^{\left(n(2p-i-1)-\frac{1}{2}(n^2-n)-(\sum_{j=1}^n i_j)\right)} \frac{[i]}{([p-i-1]!)([n+i-p]!)} F^n x_{0,2p-i-1} \\ & = \Phi(\rho_{i_1, \dots, i_n, 2p-i-1}) \end{aligned}$$

□

6.6 The Partial Trace of $\alpha\beta$ and $\beta\alpha$

We want to prove the following:

$$\begin{aligned} & \begin{array}{c} \boxed{\alpha} \\ \boxed{\beta} \end{array} = \begin{array}{c} \boxed{\beta} \\ \boxed{\alpha} \end{array} = \begin{array}{c} \boxed{\alpha} \\ \boxed{\beta} \end{array} = \begin{array}{c} \boxed{\beta} \\ \boxed{\alpha} \end{array} \\ & = -\gamma \begin{array}{c} \boxed{f_{p-1}} \\ \boxed{f_{p-1}} \end{array} \end{aligned}$$

Note that the second two relations follow from the capping and uncapping relations, or by rotating the diagrams. Hence we only need prove the first two relations.

We prove them by showing that both partial traces are equal to the second endomorphism

ε on \mathcal{P}_1^+ .

6.6.1 The partial trace of $\beta\alpha$

We want to show that these are equivalent to $\Phi(\rho_{i_1, \dots, i_n, 2p-2})$, from section 6.5, which takes the form:

$$\begin{aligned} \Phi(\rho_{i_1, \dots, i_{p-1}, 2p-2}) &= q^{\binom{(p-1)(2p-2) - \frac{1}{2}(p-1)(p-2) - (\sum_{j=1}^{p-1} i_j)}{}} \frac{(-1)^{p-2}}{([p-2]!)} F^{p-1} x_{0, 2p-2} \\ \Phi(\rho_{i_1, \dots, i_n, 2p-2}) &= 0, \quad n \neq p-1 \end{aligned}$$

For the first relation, consider $X^{\otimes 2p-2} \otimes \cap$. It's elements take the form

$q^{-1} \rho_{i_1, \dots, i_n, 2p-2} \otimes \nu_{10} - \rho_{i_1, \dots, i_n, 2p-2} \otimes \nu_{01}$. We want to apply $(\beta\alpha \otimes 1)$ to this.

From section 5.3.3, we had that given $x \in X_{k, 2p-1}$, $0 \leq k \leq p-1$,

$$\beta(\alpha(x)) = e_x \frac{([2p-k-1]!)}{([k]!)[p]} F^k x_{0, 2p-1}$$

We then have:

$$\begin{aligned} E^{n+1}(\rho_{i_1, \dots, i_n, 2p-2} \otimes \nu_1) &= \lambda_{n, n+1} (E^n \otimes K^n E)(\rho_{i_1, \dots, i_n, 2p-2} \otimes \nu_1) \\ &= q^{\binom{n(2p-2) - \frac{1}{2}(n^2-n) + n - (\sum_{j=1}^n i_j)}{}} \lambda_{n, n+1} ([n]!) x_{0, 2p-1} \\ \beta(\alpha(\rho_{i_1, \dots, i_n, 2p-2} \otimes \nu_1)) &= q^{\binom{n(2p-1) - \frac{1}{2}(n^2-n) - (\sum_{j=1}^n i_j)}{}} \times \\ &\quad \times \lambda_{n, n+1} \frac{([n]!)([2p-n-2]!)}{([n+1]!)[p]} F^{n+1} x_{0, 2p-1} \\ &= q^{\binom{n(2p-1) - \frac{1}{2}(n^2-n) - (\sum_{j=1}^n i_j)}{}} \lambda_{n, n+1} \frac{([2p-n-2]!)}{[n+1][p]} \times \\ &\quad \times \left((F^{n+1} x_{0, 2p-2}) \otimes \nu_0 + q^{n-2p+2} [n+1] (F^n x_{0, 2p-2}) \otimes \nu_1 \right) \\ E^n(\rho_{i_1, \dots, i_n, 2p-2} \otimes \nu_0) &= \lambda_{n+1, n+1} (E^n \otimes K^n)(\rho_{i_1, \dots, i_n, 2p-2} \otimes \nu_0) \\ &= q^{\binom{n(2p-2) - \frac{1}{2}(n^2-n) + n - (\sum_{j=1}^n i_j)}{}} ([n]!) x_{0, 2p-1} \\ \beta(\alpha(\rho_{i_1, \dots, i_n, 2p-2} \otimes \nu_0)) &= q^{\binom{n(2p-1) - \frac{1}{2}(n^2-n) - (\sum_{j=1}^n i_j)}{}} \frac{([n]!)([2p-n-1]!)}{([n]!)[p]} F^n x_{0, 2p-1} \\ &= q^{\binom{n(2p-1) - \frac{1}{2}(n^2-n) - (\sum_{j=1}^n i_j)}{}} \frac{([2p-n-1]!)}{[p]} \times \\ &\quad \times \left((F^n x_{0, 2p-2}) \otimes \nu_0 + q^{n-2p+1} [n] (F^{n-1} x_{0, 2p-2}) \otimes \nu_1 \right) \end{aligned}$$

Note that due to the appearance of E^{n+1} in the above, we will have to treat the case $n = p-1$ separately. For $0 \leq n \leq p-2$, we have:

$$\begin{aligned}
& (\beta\alpha \otimes 1)(q^{-1}\rho_{i_1, \dots, i_n, 2p-2} \otimes \nu_{10} - \rho_{i_1, \dots, i_n, 2p-2} \otimes \nu_{01}) = \\
& q^{\binom{n(2p-1) - \frac{1}{2}(n^2-n) - 1 - (\sum_{j=1}^n i_j)}{}} \lambda_{n, n+1} \frac{([2p-n-2]!)}{[n+1][p]} \times \\
& \times \left((F^{n+1}x_{0, 2p-2}) \otimes \nu_{00} + q^{n-2p+2}[n+1](F^n x_{0, 2p-2}) \otimes \nu_{10} \right) \\
& - q^{\binom{n(2p-1) - \frac{1}{2}(n^2-n) - (\sum_{j=1}^n i_j)}{}} \frac{([2p-n-1]!)}{[p]} \times \\
& \times \left((F^n x_{0, 2p-2}) \otimes \nu_{01} + q^{n-2p+1}[n](F^{n-1}x_{0, 2p-2}) \otimes \nu_{11} \right)
\end{aligned}$$

Applying $1^{\otimes 2p-2} \otimes \cup$ to this, we get:

$$\begin{aligned}
& q^{\binom{n(2p-1) - \frac{1}{2}(n^2-n) - 1 - (\sum_{j=1}^n i_j)}{}} \lambda_{n, n+1} \frac{([2p-n-2]!)}{[n+1][p]} q^{n+2p+2}[n+1]F^n x_{0, 2p-2} \\
& + q^{\binom{n(2p-1) - \frac{1}{2}(n^2-n) + 1 - (\sum_{j=1}^n i_j)}{}} \frac{([2p-n-1]!)}{[p]} F^n x_{0, 2p-2} \\
& = q^{\binom{n(2p-1) - \frac{1}{2}(n^2-n) - 1 - (\sum_{j=1}^n i_j)}{}} \frac{([2p-n-2]!)}{[p]} \left([n+1] + [2p-n-1] \right) F^n x_{0, 2p-2} \\
& = q^{\binom{n(2p-1) - \frac{1}{2}(n^2-n) - 1 - (\sum_{j=1}^n i_j)}{}} \frac{([2p-n-2]!)}{[p]} \left([n+1] - [n+1] \right) F^n x_{0, 2p-2} \\
& = 0
\end{aligned}$$

For the case $n = p - 1$, as $\rho_{i_1, \dots, i_{p-1}, 2p-2} \otimes \nu_1 \in X_{p, 2p-1}$, we have

$$\begin{aligned}
& (\beta\alpha \otimes 1)(q^{-1}\rho_{i_1, \dots, i_{p-1}, 2p-2} \otimes \nu_{10} - \rho_{i_1, \dots, i_{p-1}, 2p-2} \otimes \nu_{01}) = \\
& - q^{\binom{(p-1)(2p-1) - \frac{1}{2}(p-1)(p-2) - (\sum_{j=1}^{p-1} i_j)}{}} \frac{([p]!)}{[p]} \times \\
& \times \left((F^{p-1}x_{0, 2p-2}) \otimes \nu_{01} + q^{-p}[p-1](F^{p-2}x_{0, 2p-2}) \otimes \nu_{11} \right)
\end{aligned}$$

Applying $1^{\otimes 2p-2} \otimes \cup$ to this, we get:

$$q^{\binom{(p-1)(2p-1) + 1 - \frac{1}{2}(p-1)(p-2) - (\sum_{j=1}^{p-1} i_j)}{}} ([p-1]!) F^{p-1} x_{0, 2p-2}$$

Dividing by $\gamma = (-1)^{p-1}([p-1]!)^2$ we get:

$$\begin{aligned}
& (-1)^{p-2} q^{\binom{(p-1)(2p-2) - \frac{1}{2}(p-1)(p-2) - (\sum_{j=1}^{p-1} i_j)}{}} \frac{1}{([p-1]!)} F^{p-1} x_{0, 2p-2} \\
& = \Phi(\rho_{i_1, \dots, i_{p-1}, 2p-2})
\end{aligned}$$

6.6.2 The partial trace of $\alpha\beta$

Consider again $X^{\otimes 2p-2} \otimes \cap$ with elements of the form

$$q^{-1}\rho_{i_1, \dots, i_n, 2p-2} \otimes \nu_{10} - \rho_{i_1, \dots, i_n, 2p-2} \otimes \nu_{01}.$$

From section 5.3.3, given $x \in X_{k,2p-1}$, $p \leq k \leq 2p-1$, we have:

$$\alpha(\beta(x)) = f_x \frac{([k]!)}{([2p-k-1]!)[p]} E^{2p-k-1} x_{2p-1,2p-1}$$

We then have:

$$\begin{aligned} F^{2p-2-n}(\rho_{i_1, \dots, i_n, 2p-2} \otimes \nu_1) &= \lambda_{0,2p-2-n}(F^{2p-2-n} \otimes 1)(\rho_{i_1, \dots, i_n, 2p-2} \otimes \nu_1) \\ &= q \binom{n(2p-2) - \frac{1}{2}(n^2-n) - (\sum_{j=1}^n i_j)}{([2p-2-n]!)} x_{2p-1,2p-1} \\ \alpha(\beta(\rho_{i_1, \dots, i_n, 2p-2} \otimes \nu_1)) &= q \binom{n(2p-2) - \frac{1}{2}(n^2-n) - (\sum_{j=1}^n i_j)}{[p]} \frac{([n+1]!)}{[p]} E^{2p-n-2} x_{2p-1,2p-1} \\ &= q \binom{n(2p-2) - \frac{1}{2}(n^2-n) - (\sum_{j=1}^n i_j)}{[p]} \times \\ &\quad \times \left([2p-n-2](E^{2p-n-3} x_{2p-2,2p-2}) \otimes \nu_0 \right. \\ &\quad \left. + q^{n-2p+2}(E^{2p-n-2} x_{2p-2,2p-2}) \otimes \nu_1 \right) \end{aligned}$$

$$\begin{aligned} F^{2p-1-n}(\rho_{i_1, \dots, i_n, 2p-2} \otimes \nu_0) &= \lambda_{1,2p-1-n}(K^{-1} F^{2p-2-n} \otimes F)(\rho_{i_1, \dots, i_n, 2p-2} \otimes \nu_0) \\ &= q \binom{n(2p-2) + 2p-2 - \frac{1}{2}(n^2-n) - (\sum_{j=1}^n i_j)}{\times} \\ &\quad \times ([2p-2-n]!) \lambda_{1,2p-1-n} x_{2p-1,2p-1} \\ \alpha(\beta(\rho_{i_1, \dots, i_n, 2p-2} \otimes \nu_0)) &= q \binom{n(2p-2) + 2p-2 - \frac{1}{2}(n^2-n) - (\sum_{j=1}^n i_j)}{[2p-1-n][p]} \frac{([n]!)}{\times} \\ &\quad \times \lambda_{1,2p-1-n} E^{2p-n-1} x_{2p-1,2p-1} \\ &= q \binom{n(2p-2) + 2p-2 - \frac{1}{2}(n^2-n) - (\sum_{j=1}^n i_j)}{[2p-1-n][p]} \frac{([n]!) \lambda_{1,2p-1-n}}{\times} \\ &\quad \times \left([2p-n-1](E^{2p-n-2} x_{2p-2,2p-2}) \otimes \nu_0 \right. \\ &\quad \left. + q^{n+1-2p}(E^{2p-n-1} x_{2p-2,2p-2}) \otimes \nu_1 \right) \end{aligned}$$

Note that as $\rho_{i_1, \dots, i_n, 2p-2} \otimes \nu_1 \in X_{n+1,2p-1}$, we need to consider the case $n = p-1$, which we treat separately.

For $p \leq n \leq 2p-2$, we have $(\alpha\beta \otimes 1)(q^{-1}\rho_{i_1, \dots, i_n, 2p-2} \otimes \nu_{10} - \rho_{i_1, \dots, i_n, 2p-2} \otimes \nu_{01}) =$

$$\begin{aligned} & q \binom{n(2p-2) - 1 - \frac{1}{2}(n^2-n) - (\sum_{j=1}^n i_j)}{[p]} \frac{([n+1]!)}{\times} \\ & \times \left([2p-n-2](E^{2p-n-3} x_{2p-2,2p-2}) \otimes \nu_{00} + q^{n-2p+2}(E^{2p-n-2} x_{2p-2,2p-2}) \otimes \nu_{10} \right) \\ & - q \binom{n(2p-2) + 2p-2 - \frac{1}{2}(n^2-n) - (\sum_{j=1}^n i_j)}{[2p-1-n][p]} \frac{([n]!) \lambda_{1,2p-1-n}}{\times} \\ & \times \left([2p-n-1](E^{2p-n-2} x_{2p-2,2p-2}) \otimes \nu_{01} + q^{n+1-2p}(E^{2p-n-1} x_{2p-2,2p-2}) \otimes \nu_{11} \right) \end{aligned}$$

Applying $(1^{\otimes 2p-2} \otimes \cup)$ to this we get:

$$\begin{aligned}
& q^{\binom{n(2p-2)-1-\frac{1}{2}(n^2-n)-(\sum_{j=1}^n i_j)}{[p]}} \frac{([n+1]!)}{[p]} q^{n-2p+2} E^{2p-n-2} x_{2p-2,2p-2} \\
& + q^{\binom{(n(2p-2)+2p-1-\frac{1}{2}(n^2-n)-(\sum_{j=1}^n i_j)}{[p]}} \frac{([n]!) \lambda_{1,2p-1-n}}{[p]} E^{2p-n-2} x_{2p-2,2p-2} \\
& = q^{\binom{(n(2p-2)+n+1-\frac{1}{2}(n^2-n)-(\sum_{j=1}^n i_j)}{[p]}} \frac{([n]!)}{[p]} \left([n+1] + [2p-1-n] \right) E^{2p-n-2} x_{2p-2,2p-2} \\
& = q^{\binom{(n(2p-2)+n+1-\frac{1}{2}(n^2-n)-(\sum_{j=1}^n i_j)}{[p]}} \frac{([n]!)}{[p]} \left([n+1] - [n+1] \right) E^{2p-n-2} x_{2p-2,2p-2} \\
& = 0
\end{aligned}$$

For the case $n = p - 1$, noting that $\rho_{i_1, \dots, i_n, 2p-2} \otimes \nu_0 \in X_{p-1, 2p-2}$, we have

$$\begin{aligned}
& (\alpha\beta \otimes 1)(q^{-1} \rho_{i_1, \dots, i_n, 2p-2} \otimes \nu_{10} - \rho_{i_1, \dots, i_n, 2p-2} \otimes \nu_{01}) = (\alpha\beta \otimes 1)(q^{-1} \rho_{i_1, \dots, i_n, 2p-2} \otimes \nu_{10}) = \\
& q^{\binom{(p-1)(2p-2)-1-\frac{1}{2}(p-1)(p-2)-(\sum_{j=1}^{p-1} i_j)}{[p]}} \frac{([p]!)}{[p]} \times \\
& \times \left([p-1](E^{p-2} x_{2p-2, 2p-2}) \otimes \nu_{00} + q^{1-p}(E^{p-1} x_{2p-2, 2p-2}) \otimes \nu_{10} \right)
\end{aligned}$$

Applying $(1^{\otimes 2p-2} \otimes \cup)$ to this we get:

$$\begin{aligned}
& q^{\binom{(p-1)(2p-2)-1-\frac{1}{2}(p-1)(p-2)-(\sum_{j=1}^{p-1} i_j)}{[p]}} \frac{([p]!)}{[p]} q^{1-p} E^{p-1} x_{2p-2, 2p-2} \\
& = -q^{\binom{(p-1)(2p-2)-\frac{1}{2}(p-1)(p-2)-(\sum_{j=1}^{p-1} i_j)}{[p-1]}} \frac{([p-1]!)}{[p-1]} E^{p-1} x_{2p-2, 2p-2}
\end{aligned}$$

Dividing by γ , we get:

$$(-1)^{p-2} q^{\binom{(p-1)(2p-2)-\frac{1}{2}(p-1)(p-2)-(\sum_{j=1}^{p-1} i_j)}{[p-1]}} \frac{1}{([p-1]!)} E^{p-1} x_{2p-2, 2p-2}$$

We need this with F^{p-1} instead of E^{p-1} . To change this, we need equations A.12 and A.13:

$$\begin{aligned}
E^n x_{z,z} &= \sum_{j_k} q^{\binom{\frac{1}{2}(z-n)(z-n+1)-(\sum_{k=1}^{z-n} j_k)}{[n]}} ([n]!) \rho_{j_1, \dots, j_{z-n}, z} \\
F^n x_{0,z} &= \sum_{i_j} q^{\binom{\frac{1}{2}(n^2+n)-(\sum_{j=1}^n i_j)}{[n]}} ([n]!) \rho_{i_1, \dots, i_n, z}
\end{aligned}$$

From this we have that $E^n x_{2n, 2n} = F^n x_{0, 2n}$. Hence:

$$\begin{aligned}
& (-1)^{p-2} q^{\binom{(p-1)(2p-2)-\frac{1}{2}(p-1)(p-2)-(\sum_{j=1}^{p-1} i_j)}{[p-1]}} \frac{1}{([p-1]!)} E^{p-1} x_{2p-2, 2p-2} \\
& = (-1)^{p-2} q^{\binom{(p-1)(2p-2)-\frac{1}{2}(p-1)(p-2)-(\sum_{j=1}^{p-1} i_j)}{[p-1]}} \frac{1}{([p-1]!)} F^{p-1} x_{2p-2, 2p-2} \\
& = \Phi(\rho_{i_1, \dots, i_{p-1}, 2p-2})
\end{aligned}$$

6.7 The homomorphisms $\mathcal{P}_i^\pm \rightarrow \mathcal{P}_{p-i}^\mp$

In section 4.4.3, we found that there were homomorphisms $\theta : \mathcal{P}_i^+ \rightarrow \mathcal{P}_{p-i}^-$, $\Gamma : \mathcal{P}_{p-i}^- \rightarrow \mathcal{P}_i^+$, given by:

$$\begin{aligned} \theta(a_m) &= 0 & \Gamma(\bar{a}_n) &= 0 \\ \theta(b_m) &= f_1 \bar{x}_m + f_2 \bar{y}_m & \Gamma(\bar{b}_n) &= k_1 x_n + k_2 y_n \\ \theta(x_n) &= f_2 \bar{a}_n & \Gamma(\bar{x}_m) &= k_2 a_m \\ \theta(y_n) &= f_1 \bar{a}_n & \Gamma(\bar{y}_m) &= k_1 a_m \end{aligned}$$

for $0 \leq m \leq i-1$, $0 \leq n \leq p-i-1$, and $f_1, f_2, k_1, k_2 \in \mathbb{K}$. We denote the case $f_1 = 1, f_2 = 0$ by θ_1 , $f_1 = 0, f_2 = 1$ by θ_2 , $k_1 = 1, k_2 = 0$ by Γ_1 , and $k_1 = 0, k_2 = 1$ by Γ_2 .

We want to describe these homomorphisms diagrammatically. For θ , this will be a diagram given by

$$\tilde{\theta}_j : X^{\otimes 2p-1-i} \rightarrow \mathcal{P}_i^+ \rightarrow \mathcal{P}_{p-i}^- \rightarrow X^{\otimes (2p-1+i)}$$

Note that there are two copies of \mathcal{P}_{p-i}^- appearing in $X^{\otimes 2p-1+i}$, one in the weight spaces $X_{0,2p-1+i}, \dots, X_{p+i,2p-1+i}$, the other in the weight spaces $X_{p-1,2p-1+i}, \dots, X_{2p-1+i,2p-1+i}$. Denote the maps onto these as $\theta_{j,l}$, $\theta_{j,u}$ respectively, with $j \in \{1, 2\}$. In terms of the weight spaces, these maps can be characterized as:

$$\begin{aligned} \theta_{1,l} : X_{k,2p-i-1} &\rightarrow X_{k+i-p,2p+i-1} & p-i \leq k \leq 2p-i-1 \\ \theta_{2,l} : X_{k,2p-i-1} &\rightarrow X_{k+i,2p+i-1} & 0 \leq k \leq p-1 \\ \theta_{1,u} : X_{k,2p-i-1} &\rightarrow X_{k+i,2p+i-1} & p-i \leq k \leq 2p-i-1 \\ \theta_{2,u} : X_{k,2p-i-1} &\rightarrow X_{k+p+i,2p+i-1} & 0 \leq k \leq p-1 \end{aligned}$$

From how these maps act on the weight spaces, we can conclude that they can't be given diagrammatically in terms of Temperley-Lieb elements, and so must be in terms of α and β . As the diagrams will have $2p-i-1$ points at the top and $2p+i-1$ points at the bottom, then considering the properties of α and β , we see that the diagrams for $\theta_{1,l}$ and $\theta_{2,u}$ must be of the form:

$$\theta_{1,l} := \begin{array}{c} | \\ \boxed{\beta} \\ | \end{array} \begin{array}{c} \curvearrowright \\ | \\ i \end{array}, \quad \theta_{2,u} := \begin{array}{c} | \\ \boxed{\alpha} \\ | \end{array} \begin{array}{c} \curvearrowright \\ | \\ i \end{array}$$

We also conjecture that the diagrams for $\theta_{2,l}$ and $\theta_{1,u}$ are of the form:

$$\theta_{2,l} := \begin{array}{c} | \\ \boxed{\alpha} \\ \boxed{\beta} \\ | \end{array} \begin{array}{c} \curvearrowright \\ | \\ i \end{array}, \quad \theta_{1,u} := \begin{array}{c} | \\ \boxed{\beta} \\ \boxed{\alpha} \\ | \end{array} \begin{array}{c} \curvearrowright \\ | \\ i \end{array}$$

From the properties required for $\theta_{2,l}$, $\theta_{1,u}$, i.e. the number of strings along the top and bottom, and how they act on weight spaces, we see that the diagrams must either be of the above form, or else a similar diagram with the bottom box shifted rightwards, or some linear combination of these diagrams and Temperley-Lieb elements. We have chosen the simplest case as our conjectured diagrams.

In terms of weight spaces, Γ can be characterized as:

$$\begin{array}{ll} \Gamma_{1,l} : X_{k,2p+i-1} \rightarrow X_{k-i,2p-i-1} & i \leq k \leq p+i-1 \\ \Gamma_{2,l} : X_{k,2p+i-1} \rightarrow X_{k+p-i,2p-i-1} & 0 \leq k \leq p-1 \\ \Gamma_{1,u} : X_{k,2p+i-1} \rightarrow X_{k-p+i,2p-i-1} & p+i \leq k \leq 2p+i-1 \\ \Gamma_{2,u} : X_{k,2p+i-1} \rightarrow X_{k-i,2p-i-1} & p \leq k \leq 2p-1 \end{array}$$

Again from how these maps act on the weight spaces, we can conclude that the diagrams for $\Gamma_{1,u}$ and $\Gamma_{2,l}$ take the form:

$X^{\otimes 2p+i-1}$ is two, we must then have the following:

$$\theta_{1,l}\Gamma_{2,l} = \theta_{2,l}\Gamma_{1,l}$$

$$\theta_{1,l}\Gamma_{2,u} = \theta_{2,l}\Gamma_{1,u}$$

$$\theta_{1,u}\Gamma_{2,l} = \theta_{2,u}\Gamma_{1,l}$$

$$\theta_{1,u}\Gamma_{2,u} = \theta_{2,u}\Gamma_{1,u}$$

Hence the second endomorphism on the two copies of \mathcal{P}_i^- in $X^{\otimes 3p-i-1}$ is:

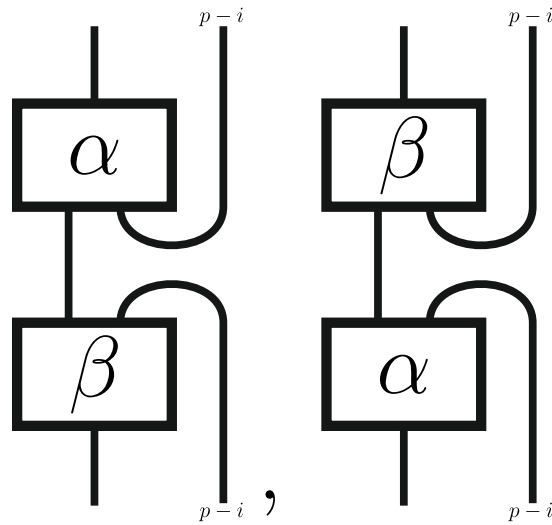

The second endomorphism should square to zero, and indeed, using the partial trace of $\alpha\beta$, we have:

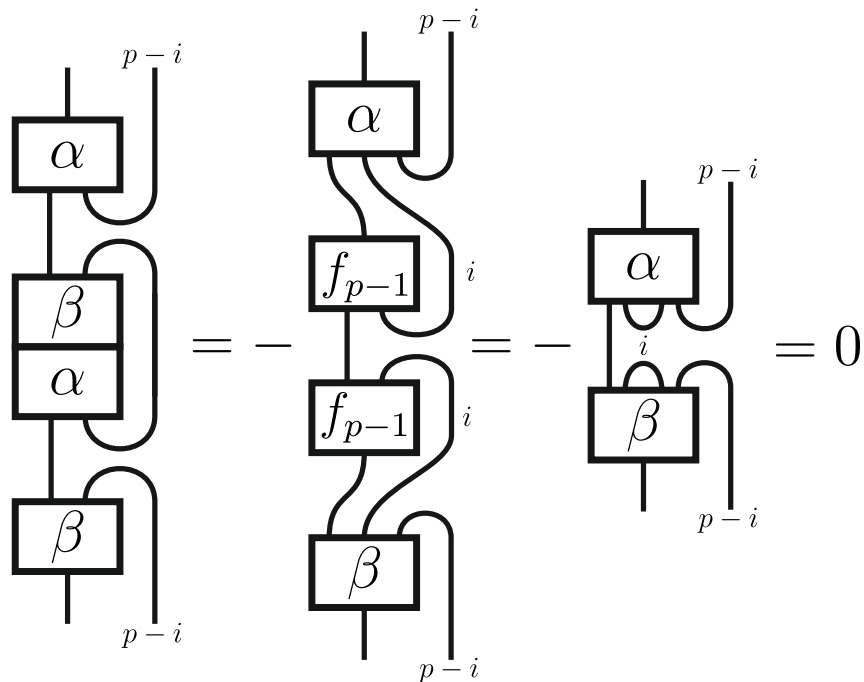

Note that given our conjectured diagrams above, we should expect the following relations to hold:

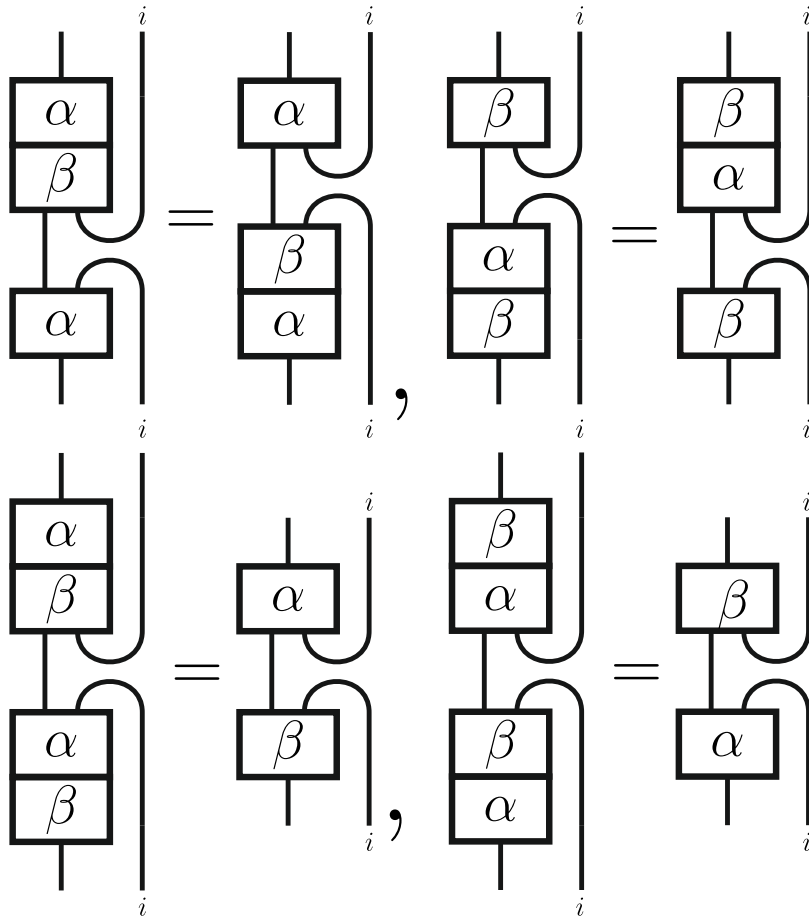

We showed that the case $i = 1$ is true in section 5.4.2 using the rotation relation.

6.8 A Conjecture of the formula for the indecomposable projections:

We showed in section 5.3.6 that $\alpha\beta + \beta\alpha = \gamma f_{2p-1}$, and conjecture that the projections onto \mathcal{P}_i^+ and $\mathcal{P}_i^- \oplus \mathcal{P}_i^-$ for $1 \leq i \leq p - 1$ can be given diagrammatically by the following:

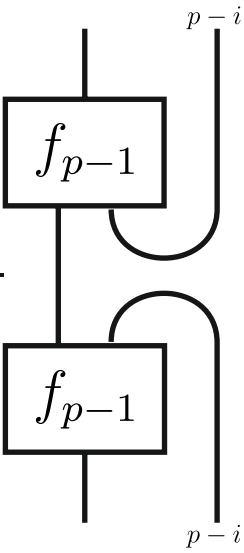
$$\mathcal{P}_i^+ := f_{2p-i-1} + \frac{[i]}{[p]}$$

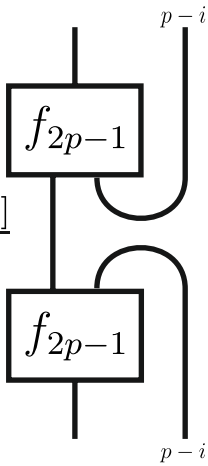
$$\mathcal{P}_i^- \oplus \mathcal{P}_i^- := f_{3p-i-1} + \frac{[p+i]}{[2p]}$$

where the boxes represent the $(p-1)$ or $(2p-1)$ th Jones-Wenzl projections.

We claim that these diagrams can be expanded in terms of the $(p-1)$ or $(2p-1)$ th Jones-Wenzl projections, and simplified so that the quantum integers $[p]$ and $[2p]$ do not appear in any denominator, so that the diagrams are finite when evaluated for the value of p .

Given the simplified diagram, substituting each $(2p-1)$ th JW projection with either $\gamma^{-1}\alpha\beta$ or $\gamma^{-1}\beta\alpha$ gives a projection onto \mathcal{P}_i^- .

For $i = 1, 2$ this gives:

$$\mathcal{P}_{p-1}^+ := f_p + \frac{[p-1]}{[p]}$$

$$= f_{p-1} - \frac{[p-1]}{[p]} f_{p-1} + \frac{[p-1]}{[p]} f_{p-1}$$

$$= f_{p-1}$$

$$\mathcal{P}_{p-2}^+ := f_{p-1} - \frac{[p]}{[p-1]} f_{p-1} + \frac{[p-1]}{[p+1]} f_{p-1} + \frac{[p-1]}{[p+1]} f_{p-1}$$

$$- \left(\frac{[p-1]}{[p]} + \frac{[p-1]^2}{[p][p+1]} \right) f_{p-1} + \left(\frac{[p-1][p-2]}{[p][p+1]} + \frac{[p-2]}{[p]} \right) f_{p-1}$$

$$\begin{aligned}
&= \boxed{f_{p-1}} \parallel \parallel - \frac{[p]}{[p-1]} \boxed{f_{p-1}} \begin{array}{c} \cup \\ \cap \end{array} + \frac{[p-1]}{[p+1]} \begin{array}{c} \cup \\ \boxed{f_{p-1}} \\ \boxed{f_{p-1}} \\ \cap \end{array} \\
&+ \frac{[p-1]}{[p+1]} \begin{array}{c} \boxed{f_{p-1}} \\ \boxed{f_{p-1}} \\ \cap \end{array} \parallel \parallel - \frac{[2][p-1]}{[p+1]} \begin{array}{c} \boxed{f_{p-1}} \\ \boxed{f_{p-1}} \\ \parallel \parallel \end{array} + \frac{[2][p-2]}{[p+1]} \begin{array}{c} \boxed{f_{p-1}} \\ \boxed{f_{p-1}} \\ \parallel \parallel \end{array}
\end{aligned}$$

where for the second case, we used:

$$\frac{[n-1]}{[n][n+1]} = \frac{[2]}{[n+1]} - \frac{1}{[n]}$$

The negative case is:

$$\mathcal{P}_{p-1}^- \oplus \mathcal{P}_{p-1}^- := \boxed{f_{2p-1}} \parallel \parallel$$

$$\mathcal{P}_{p-1}^- := \begin{array}{c} \boxed{\alpha} \\ \boxed{\beta} \end{array} \parallel \parallel , \begin{array}{c} \boxed{\beta} \\ \boxed{\alpha} \end{array} \parallel \parallel$$

$$\begin{aligned}
\mathcal{P}_{p-2}^- \oplus \mathcal{P}_{p-2}^- := & \begin{array}{c} \text{---} \\ | \\ \boxed{f_{2p-1}} \\ | \\ \text{---} \end{array} \Bigg| \Bigg| - \frac{[2p]}{[2p+1]} \begin{array}{c} \text{---} \\ | \\ \boxed{f_{2p-1}} \\ | \\ \text{---} \end{array} \begin{array}{c} \cup \\ \cup \end{array} + \frac{[2p-1]}{[2p+1]} \begin{array}{c} \text{---} \\ | \\ \boxed{f_{2p-1}} \\ | \\ \boxed{f_{2p-1}} \\ | \\ \text{---} \end{array} \begin{array}{c} \cup \\ \cup \end{array} \\
& + \frac{[2p-1]}{[2p+1]} \begin{array}{c} \text{---} \\ | \\ \boxed{f_{2p-1}} \\ | \\ \boxed{f_{2p-1}} \\ | \\ \text{---} \end{array} \begin{array}{c} \cup \\ \cup \end{array} - \frac{[2][2p-1]}{[2p+1]} \begin{array}{c} \text{---} \\ | \\ \boxed{f_{2p-1}} \\ | \\ \boxed{f_{2p-1}} \\ | \\ \text{---} \end{array} \begin{array}{c} \cup \\ \cup \end{array} + \frac{[2][2p-2]}{[2p+1]} \begin{array}{c} \text{---} \\ | \\ \boxed{f_{2p-1}} \\ | \\ \boxed{f_{2p-1}} \\ | \\ \text{---} \end{array} \begin{array}{c} \cup \\ \cup \end{array}
\end{aligned}$$

By using the inductive formula for the Jones-Wenzl projections, we can rewrite the formula for the indecomposable projections to get the following inductive formula:

$$\begin{aligned}
\mathcal{P}_{i-1}^+ := & \begin{array}{c} \text{---} \\ | \\ \boxed{\mathcal{P}_i^+} \\ | \\ \text{---} \end{array} \Bigg| \Bigg| - \left(\frac{[i]}{[p]} + \frac{[i]^2[2p-i-1]}{[p][i+1][2p-i]} \right) \begin{array}{c} \text{---} \\ | \\ \boxed{f_{p-1}} \\ | \\ \boxed{f_{p-1}} \\ | \\ \text{---} \end{array} \begin{array}{c} p-i \\ p-i \end{array} \\
& - \frac{[2p-i-1]}{[2p-i]} \begin{array}{c} \text{---} \\ | \\ \boxed{\mathcal{P}_i^+} \\ | \\ \boxed{\mathcal{P}_i^+} \\ | \\ \text{---} \end{array} \begin{array}{c} p-i \\ p-i \end{array} + \left(\frac{[i-1]}{[p]} + \frac{[i][i-1][2p-i-1]}{[p][i+1][2p-i]} \right) \begin{array}{c} \text{---} \\ | \\ \boxed{f_{p-1}} \\ | \\ \boxed{f_{p-1}} \\ | \\ \text{---} \end{array} \begin{array}{c} p-i-1 \\ p-i-1 \end{array} \\
& + \frac{[i][2p-i-1]}{[p][2p-i]} \begin{array}{c} \text{---} \\ | \\ \boxed{f_{p-1}} \\ | \\ \boxed{\mathcal{P}_i^+} \\ | \\ \text{---} \end{array} \begin{array}{c} p-i \\ p-i-1 \end{array} + \frac{[i][2p-i-1]}{[p][2p-i]} \begin{array}{c} \text{---} \\ | \\ \boxed{\mathcal{P}_i^+} \\ | \\ \boxed{f_{p-1}} \\ | \\ \text{---} \end{array} \begin{array}{c} p-i-1 \\ p-i \end{array}
\end{aligned}$$

where the starting point is just the formula for the projection on \mathcal{P}_{p-1}^+ , i.e. $f_{p-1} \otimes 1$.

As evidence for our conjectured formulae, we can show that they are idempotent, and contain the relevant projection. For this we first need the following:

$$\boxed{f_n} \text{ with loop } k = \frac{[n+1]}{[n-k+1]} \boxed{f_{n-k}}$$

Taking the square of our formula for \mathcal{P}_i^+ , we get:

$$\left(\boxed{f_{2p-i-1}} + \frac{[i]}{[p]} \boxed{f_{p-1}} \right)^2 = \boxed{f_{2p-i-1}} + \frac{[i]}{[p]} \boxed{f_{p-1}} + \frac{[i]}{[p]} \boxed{f_{p-1}} + \frac{[i]^2}{[p]^2} \boxed{f_{p-1}}$$

$$= \begin{array}{c} | \\ \boxed{f_{2p-i-1}} \\ | \end{array} + \frac{[i]^2}{[p]^2} \begin{array}{c} | \\ \boxed{f_{p-1}} \\ | \\ \boxed{f_{p-1}} \\ | \\ \boxed{f_{p-1}} \\ | \end{array}$$

$$= \begin{array}{c} | \\ \boxed{f_{2p-i-1}} \\ | \end{array} + \frac{[i]}{[p]} \begin{array}{c} | \\ \boxed{f_{p-1}} \\ | \\ \boxed{f_{p-1}} \\ | \end{array}$$

Hence the formulae is idempotent. Further, applying the second endomorphism ε to the diagram, we get:

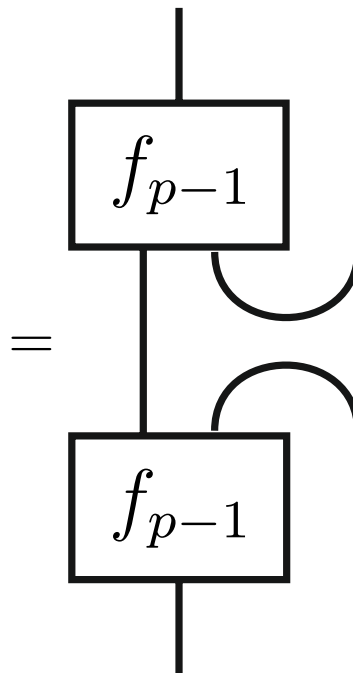
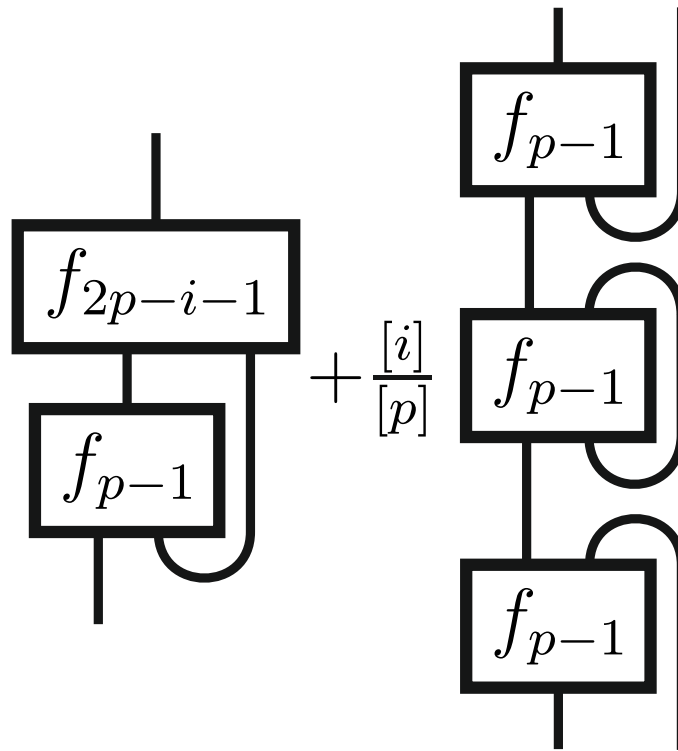

So taking the composition of ε with the conjectured formula gives ε . However, from section 4.4, we see that the only homomorphism with this property, is the identity on \mathcal{P}_i^+ , so the conjectured formula must contain the identity on \mathcal{P}_i^+ , i.e. it contains the projection onto \mathcal{P}_i^+ .

Appendix A

Combinatorial Identities

Throughout this thesis we use a number of combinatorial identities related to quantum integers, we record these identities here.

A.1 Quantum Integers

The quantum integer $[n]$ is defined by:

$$[n] := \frac{q^n - q^{-n}}{q - q^{-1}}$$

for $q \in \mathbb{K} \setminus \{0, \pm 1\}$. Alternatively, it can be written:

$$[n] = q^{n-1} + q^{n-3} + \dots + q^{3-n} + q^{1-n}$$

for $q \in \mathbb{K}$. It satisfies:

$$[m - a] + [m + 1][a] = [m][a + 1] \tag{A.1}$$

for $m \geq a$.

Proposition A.1.

$$\sum_{i=0}^n [2i + 1] = [n + 1]^2$$

Proof. For $n = 0$ we just have $[1] = [1]^2$.

Assume true for n , then for $n + 1$ we have:

$$\begin{aligned}
\sum_{i=0}^{n+1} [2i + 1] &= \sum_{i=0}^n [2i + 1] + [2n + 3] = [n + 1]^2 + [2n + 3] \\
&= \left(\frac{q^{n+1} - q^{-n-1}}{q - q^{-1}} \right)^2 + \frac{q^{2n+3} - q^{-2n-3}}{q - q^{-1}} \\
&= \frac{q^{2n+2} - 2 + q^{-2n-2} + (q - q^{-1})(q^{2n+3} - q^{-2n-3})}{(q - q^{-1})^2} \\
&= \frac{q^{2n+2} - 2 + q^{-2n-2} + q^{2n+4} - q^{2n+2} - q^{-2n-2} + q^{2n+4}}{(q - q^{-1})^2} \\
&= \frac{q^{2n+4} - 2 + q^{2n+4}}{(q - q^{-1})^2} = \left(\frac{q^{n+2} - q^{-n-2}}{q - q^{-1}} \right)^2 \\
&= [n + 2]^2
\end{aligned}$$

□

A.2 Relations on $(\mathcal{X}_2^+)^{\otimes z}$

The quantum group $\bar{U}_q(\mathfrak{sl}_2)$ was defined in 4.1, and its relations can be used to give the following generalized conditions:

$$\Delta^k(K) = K^{\otimes k+1} \tag{A.2}$$

$$\Delta^k(E) = \sum_{i=0}^k (1^{\otimes i}) \otimes E \otimes (K^{\otimes (k-i)}) \tag{A.3}$$

$$\Delta^k(F) = \sum_{i=0}^k ((K^{-1})^{\otimes i}) \otimes F \otimes (1^{\otimes (k-i)}) \tag{A.4}$$

$$EF^k = F^k E + \left(\frac{1}{q - q^{-1}} \right) (F^{k-1} K \left(\sum_{i=0}^{k-1} q^{-2i} \right) - F^{k-1} K^{-1} \left(\sum_{i=0}^{k-1} q^{2i} \right)) \tag{A.5}$$

$$= F^k E + \left(\frac{[k]}{q - q^{-1}} \right) (q^{1-k} F^{k-1} K - q^{k-1} F^{k-1} K^{-1}) \tag{A.6}$$

$$FE^k = E^k F + \left(\frac{1}{q - q^{-1}} \right) (E^{k-1} K^{-1} \left(\sum_{i=0}^{k-1} q^{-2i} \right) - E^{k-1} K \left(\sum_{i=0}^{k-1} q^{2i} \right)) \tag{A.7}$$

$$= E^k F + \left(\frac{[k]}{q - q^{-1}} \right) (q^{1-k} E^{k-1} K^{-1} - q^{k-1} E^{k-1} K) \tag{A.8}$$

$$\Delta E^k = \sum_{i=0}^k \lambda_{i,k} E^i \otimes K^i E^{k-i} \tag{A.9}$$

$$\Delta F^k = \sum_{i=0}^k \lambda_{i,k} K^{-i} F^{k-i} \otimes F^i \tag{A.10}$$

$$\lambda_{i,k} = q^{(i^2 - ik)} \frac{([k]!)}{([i]!)[k-i]!} \tag{A.11}$$

The coefficients $\lambda_{i,k}$ can be proven by setting up recurrence relations from $(\Delta E)(\Delta E^k)$, $(\Delta E^k)(\Delta E)$. The module \mathcal{X}_2^+ has basis $\{\nu_0, \nu_1\}$, and action defined by:

$$\begin{aligned} K(\nu_0) &= q\nu_0 & K(\nu_1) &= q^{-1}\nu_1 \\ E(\nu_0) &= 0 & E(\nu_1) &= \nu_0 \\ F(\nu_0) &= \nu_1 & F(\nu_1) &= 0 \end{aligned}$$

We denote by $\rho_{i_1, \dots, i_n, z}$ the element of $(\mathcal{X}_2^+)^{\otimes z}$ with ν_1 at positions i_1, \dots, i_n , and ν_0 elsewhere. We also occasionally omit the \otimes sign, and combine indices. For example, $\rho_{1,3,5} = \nu_1 \otimes \nu_0 \otimes \nu_1 \otimes \nu_0 \otimes \nu_0 = \nu_{10100}$.

The elements of $(\mathcal{X}_2^+)^{\otimes z}$ can be described in terms of the K -action on them. For $x \in (\mathcal{X}_2^+)^{\otimes z}$, with $K(x) = \lambda x$, $\lambda \in \mathbb{K}$, we call λ the weight of x . Alternatively, for basis elements we can write this as $K(\rho_{i_1, \dots, i_n, z}) = q^{z-2n}x$, and refer to n also as the weight. $(\mathcal{X}_2^+)^{\otimes z}$ will then have the set of weights $\{q^z, q^{z-2}, \dots, q^{2-z}, q^{-z}\}$. Denoting the set of elements of $(\mathcal{X}_2^+)^{\otimes z}$ with weight q^{z-2n} by $X_{n,z}$, we have $(\mathcal{X}_2^+)^{\otimes z} = \bigcup_{i=0}^z X_{i,z}$. The weight spaces $X_{0,z}$ $X_{z,z}$ both have a single element, which we denote by $x_{0,z} := (\nu_0)^{\otimes z}$, $x_{z,z} := (\nu_1)^{\otimes z}$ respectively.

We have $\rho_{i_1, \dots, i_n, z} \in X_{n,z}$.

The $\bar{U}_q(\mathfrak{sl}_2)$ action on the basis elements satisfies the following:

$$E^n \rho_{i_1, \dots, i_n, z} = q^{\left(nz - \frac{1}{2}(n^2 - n) - \left(\sum_{j=1}^n i_j\right)\right)} ([n]!) x_{0,z} \quad (\text{A.12})$$

$$F^{z-n} \rho_{i_1, \dots, i_n, z} = q^{\left(nz - \frac{1}{2}(n^2 - n) - \left(\sum_{j=1}^n i_j\right)\right)} ([z-n]!) x_{z,z} \quad (\text{A.13})$$

$$F^k x_{0,z} = \sum_{1 \leq i_j \leq z} q^{\left(k - \left(\sum_{j=1}^k i_j\right)\right)} \left(\prod_{l=1}^k \left(\sum_{i=1}^l q^{(2i-2)} \right) \right) \rho_{i_1, \dots, i_k, z} \quad (\text{A.14})$$

$$= \sum_{1 \leq i_j \leq z} q^{\left(\frac{1}{2}(k^2 + k) - \left(\sum_{j=1}^k i_j\right)\right)} ([k]!) \rho_{i_1, \dots, i_k, z} \quad (\text{A.15})$$

$$E^k x_{z,z} = \sum_{1 \leq i_j \leq z} q^{\left(-kz + \frac{1}{2}(z^2 + z) - \left(\sum_{j=1}^{z-k} i_j\right)\right)} \left(\prod_{l=1}^k \left(\sum_{i=1}^l q^{(2i-2)} \right) \right) \rho_{i_1, \dots, i_{z-k}, z} \quad (\text{A.16})$$

$$= \sum_{1 \leq i_j \leq z} q^{\left(\frac{1}{2}(z-k)(z-k+1) - \left(\sum_{j=1}^{z-k} i_j\right)\right)} ([k]!) \rho_{i_1, \dots, i_{z-k}, z} \quad (\text{A.17})$$

$$E^k x_{z+1, z+1} = [k](E^{k-1} x_{z,z}) \otimes \nu_0 + q^{-k}(E^k x_{z,z}) \otimes \nu_1 \quad (\text{A.18})$$

$$= q^{k-z-1}[k]\nu_0 \otimes (E^{k-1} x_{z,z}) + \nu_1 \otimes (E^k x_{z,z}) \quad (\text{A.19})$$

$$F^k x_{0, z+1} = (F^k x_{0,z}) \otimes \nu_0 + q^{k-z-1}[k](F^{k-1} x_{0,z}) \otimes \nu_1 \quad (\text{A.20})$$

$$= q^{-k}\nu_0 \otimes (F^k x_{0,z}) + [k]\nu_1 \otimes (F^{k-1} x_{0,z}) \quad (\text{A.21})$$

These come from considering all contributions to the coefficient as different orderings of the integers i_1, \dots, i_n , where each ordering describes the order in which the zero's appeared. For the standard ordering with $i_1 < i_2 < \dots < i_n$, its contribution to the coefficient is just $q^{-z+i_1}q^{-z+i_2} \dots q^{-z+i_n} = q^{(-nz + \sum_{j=1}^n i_j)}$. Interchanging two integers in the ordering multiplies this by $q^{\pm 2}$, and the coefficient comes from considering all possible permutations.

For integers $1 \leq i_1 < i_2 < \dots < i_n \leq z$, we have:

$$\xi_{n,z} := \sum_{1 \leq i_j \leq z} q^{-2(\sum_{j=1}^n i_j)} = q^{-n-nz} \frac{([z]!)}{([n]!)([z-n]!)} \quad (\text{A.22})$$

$$\xi_{n,z} = q^{-2z} \xi_{n-1,z-1} + \xi_{n,z-1} \quad (\text{A.23})$$

where the recurrence relation comes from considering the two cases in $\xi_{n,z}$, when $i_n = z$ and when $i_n \neq z$.

Appendix B

The Jones-Wenzl Projections

The projections $\mathbf{f}_z : X^{\otimes z} \rightarrow \mathcal{X}_{z+1}^+ \rightarrow X^{\otimes z}$ are given by:

$$\mathbf{f}_z(\rho_{i_1, \dots, i_n, z}) = q^{\binom{nz - \frac{1}{2}(n^2 - n) - (\sum_{j=1}^n i_j)}{z-n}} \frac{([z-n]!)}{([z]!)} F^n x_{0,z}$$

The Jones-Wenzl projections in the Temperley-Lieb algebra, $TL(\delta)$, are defined by:

$$\begin{aligned} \mathbf{f}_1 &= 1 \\ \mathbf{f}_{z+1} &= \mathbf{f}_z \otimes 1 - \frac{[z]}{[z+1]} (\mathbf{f}_z \otimes 1) \mathbf{e}_z (\mathbf{f}_z \otimes 1) \end{aligned}$$

They were originally defined in [64], and are the unique projections such that $TL(2 \cos(\frac{\pi}{n})) / \mathbf{f}_{n-1}$ is positive-definite, for $3 \leq n \in \mathbb{N}$. We want to show that the projections onto \mathcal{X}_n^+ are the Jones-Wenzl projections \mathbf{f}_{n-1} .

We show this by substituting the definition for \mathbf{f}_z into the inductive relation for the Jones-Wenzl projection and show that it gives the formula for \mathbf{f}_{z+1} . For this, we need to consider two cases, $\rho_{i_1, \dots, i_n, z} \otimes \nu_0$ and $\rho_{i_1, \dots, i_n, z} \otimes \nu_1$.

We start with $\rho_{i_1, \dots, i_n, z} \otimes \nu_0$. We have:

$$\begin{aligned} \mathbf{f}_{z+1}(\rho_{i_1, \dots, i_n, z} \otimes \nu_0) &= q^{\binom{n(z+1) - \frac{1}{2}(n^2 - n) - (\sum_{j=1}^n i_j)}{z+1-n}} \frac{([z+1-n]!)}{([z+1]!)} F^n x_{0,z+1} \\ &= q^{\binom{n(z+1) - \frac{1}{2}(n^2 - n) - (\sum_{j=1}^n i_j)}{z+1-n}} \frac{([z+1-n]!)}{([z+1]!)} \times \\ &\quad \times \left((F^n x_{0,z}) \otimes \nu_0 + q^{n-z-1} [n] (F^{n-1} x_{0,z}) \otimes \nu_1 \right) \end{aligned}$$

Alternatively, we have:

$$\begin{aligned}
(\mathbf{f}_z \otimes 1)(\rho_{i_1, \dots, i_n, z} \otimes \nu_0) &= q^{\left(nz - \frac{1}{2}(n^2 - n) - \left(\sum_{j=1}^n i_j\right)\right)} \frac{([z - n]!)}{([z]!)} (F^n x_{0,z}) \otimes \nu_0 \\
&= q^{\left(nz - \frac{1}{2}(n^2 - n) - \left(\sum_{j=1}^n i_j\right)\right)} \frac{([z - n]!)}{([z]!)} \times \\
&\quad \times \left((F^n x_{0,z-1}) \otimes \nu_{00} + q^{n-z} [n] (F^{n-1} x_{0,z-1}) \otimes \nu_{10} \right) \\
\mathbf{e}_z(\mathbf{f}_z \otimes 1)(\rho_{i_1, \dots, i_n, z} \otimes \nu_0) &= q^{\left(nz - \frac{1}{2}(n^2 - n) + n - z - \left(\sum_{j=1}^n i_j\right)\right)} \frac{[n]([z - n]!)}{([z]!)} \times \\
&\quad \times \left(q^{-1} (F^{n-1} x_{0,z-1}) \otimes \nu_{10} - (F^{n-1} x_{0,z-1}) \otimes \nu_{01} \right)
\end{aligned}$$

Let $G_0 := q^{\left(nz - \frac{1}{2}(n^2 - n) + n - z - \left(\sum_{j=1}^n i_j\right)\right)} \frac{[n]([z - n]!)}{([z]!)}$, then this becomes:

$$\begin{aligned}
\mathbf{e}_z(\mathbf{f}_z \otimes 1)(\rho_{i_1, \dots, i_n, z} \otimes \nu_0) &= G_0 \left(q^{-1} (F^{n-1} x_{0,z-1}) \otimes \nu_{10} - (F^{n-1} x_{0,z-1}) \otimes \nu_{01} \right) \\
&= \sum_{1 \leq j_k \leq z-1} q^{\left(\frac{1}{2}(n^2 - n) - \left(\sum_{k=1}^{n-1} j_k\right)\right)} ([n - 1]!) G_0 \times \\
&\quad \times \left(q^{-1} \rho_{j_1, \dots, j_{n-1}, z-1} \otimes \nu_{10} - \rho_{j_1, \dots, j_{n-1}, z-1} \otimes \nu_{01} \right) \\
(\mathbf{f}_z \otimes 1) \mathbf{e}_z(\mathbf{f}_z \otimes 1)(\rho_{i_1, \dots, i_n, z} \otimes \nu_0) &= \\
\sum_{1 \leq j_k \leq z-1} q^{\left(\frac{1}{2}(n^2 - n) - \left(\sum_{k=1}^{n-1} j_k\right)\right)} ([n - 1]!) G_0 &\left(q^{\left(nz - \frac{1}{2}(n^2 - n) - 1 - z - \left(\sum_{k=1}^{n-1} j_k\right)\right)} \frac{([z - n]!)}{([z]!)} (F^n x_{0,z}) \otimes \nu_0 \right. \\
&\quad \left. - q^{\left(z(n-1) - \frac{1}{2}(n-1)(n-2) - \left(\sum_{k=1}^{n-1} j_k\right)\right)} \frac{([z - n + 1]!)}{([z]!)} (F^{n-1} x_{0,z}) \otimes \nu_1 \right)
\end{aligned}$$

We now need to use equation A.22:

$$\sum_{1 \leq i_j \leq z} q^{-2\left(\sum_{j=1}^n i_j\right)} = q^{(-n-nz)} \frac{([z]!)}{([n]!)([z - n]!)}$$

Hence we have $(\mathbf{f}_z \otimes 1) \mathbf{e}_z(\mathbf{f}_z \otimes 1)(\rho_{i_1, \dots, i_n, z} \otimes \nu_0) =$

$$\begin{aligned}
& q^{\left(\frac{1}{2}(n^2 - n) - z(n-1)\right)} \frac{([n - 1]!)([z - 1]!)}{([n - 1]!)([z - n]!)} G_0 \left(q^{\left(nz - \frac{1}{2}(n^2 - n) - 1 - z\right)} \frac{([z - n]!)}{([z]!)} (F^n x_{0,z}) \otimes \nu_0 \right. \\
& \quad \left. - q^{\left(z(n-1) - \frac{1}{2}(n-1)(n-2)\right)} \frac{([z - n + 1]!)}{([z]!)} (F^{n-1} x_{0,z}) \otimes \nu_1 \right) \\
&= G_0 \left(\frac{q^{-1}}{[z]} (F^n x_{0,z}) \otimes \nu_0 - q^{n-1} \frac{[z - n + 1]}{[z]} (F^{n-1} x_{0,z}) \otimes \nu_1 \right) \\
&= q^{\left(nz - \frac{1}{2}(n^2 - n) + n - z - \left(\sum_{j=1}^n i_j\right)\right)} \frac{[n]([z - n]!)}{([z]!)} \times \\
& \quad \times \left(\frac{q^{-1}}{[z]} (F^n x_{0,z}) \otimes \nu_0 - q^{n-1} \frac{[z - n + 1]}{[z]} (F^{n-1} x_{0,z}) \otimes \nu_1 \right)
\end{aligned}$$

Then we have that:

$$\begin{aligned}
& (\mathbf{f}_z \otimes 1 - \frac{[z]}{[z+1]}(\mathbf{f}_z \otimes 1)\mathbf{e}_z(\mathbf{f}_z \otimes 1))(\rho_{i_1, \dots, i_n, z} \otimes \nu_0) = \\
& q^{\left(nz - \frac{1}{2}(n^2 - n) - \left(\sum_{j=1}^n i_j\right)\right)} \frac{([z-n]!)}{([z]!)} (F^n x_{0,z}) \otimes \nu_0 \\
& - q^{\left(nz - \frac{1}{2}(n^2 - n) + n - z - \left(\sum_{j=1}^n i_j\right)\right)} \frac{[n]([z-n]!)}{([z]!)} \frac{[z]}{[z+1]} \times \\
& \times \left(\frac{q^{-1}}{[z]} (F^n x_{0,z}) \otimes \nu_0 - q^{n-1} \frac{[z-n+1]}{[z]} (F^{n-1} x_{0,z}) \otimes \nu_1 \right) \\
& = q^{\left(nz - \frac{1}{2}(n^2 - n) - \left(\sum_{j=1}^n i_j\right)\right)} \frac{([z-n]!)}{([z]!)} \times \\
& \times \left(\left(1 - q^{n-z-1} \frac{[n]}{[z+1]}\right) (F^n x_{0,z}) \otimes \nu_0 + q^{2n-z-1} \frac{[z-n+1][n]}{[z+1]} (F^{n-1} x_{0,z}) \otimes \nu_1 \right)
\end{aligned}$$

Note that:

$$\begin{aligned}
[z+1] - q^{n-z-1}[n] &= \frac{(q^{z+1} - q^{-z-1} - q^{n-z-1}(q^n - q^{-n}))}{(q - q^{-1})} \\
&= \frac{(q^{z+1} - q^{2n-z-1})}{(q - q^{-1})} = q^n [z - n + 1]
\end{aligned}$$

Hence we have:

$$\begin{aligned}
& q^{\left(nz - \frac{1}{2}(n^2 - n) - \left(\sum_{j=1}^n i_j\right)\right)} \frac{([z-n]!)}{([z]!)} \times \\
& \times \left(q^n \frac{[z-n+1]}{[z+1]} (F^n x_{0,z}) \otimes \nu_0 + q^{2n-z-1} \frac{[z-n+1][n]}{[z+1]} (F^{n-1} x_{0,z}) \otimes \nu_1 \right) \\
& = q^{\left(n(z+1) - \frac{1}{2}(n^2 - n) - \left(\sum_{j=1}^n i_j\right)\right)} \frac{([z-n+1]!)}{([z+1]!)} \left((F^n x_{0,z}) \otimes \nu_0 + q^{n-z-1}[n] (F^{n-1} x_{0,z}) \otimes \nu_1 \right) \\
& = \mathbf{f}_{z+1}(\rho_{i_1, \dots, i_n, z} \otimes \nu_0)
\end{aligned}$$

Hence we have proven the first case.

For the second case, we have:

$$\begin{aligned}
\mathbf{f}_{z+1}(\rho_{i_1, \dots, i_n, z} \otimes \nu_1) &= q^{\left(n(z+1) - \frac{1}{2}(n^2 + n) - \left(\sum_{j=1}^n i_j\right)\right)} \frac{([z-n]!)}{([z+1]!)} F^{n+1} x_{0,z+1} \\
&= q^{\left(nz - \frac{1}{2}(n^2 - n) - \left(\sum_{j=1}^n i_j\right)\right)} \frac{([z-n]!)}{([z+1]!)} \times \\
& \times \left((F^{n+1} x_{0,z}) \otimes \nu_0 + q^{n-z}[n+1] (F^n x_{0,z}) \otimes \nu_1 \right)
\end{aligned}$$

Alternatively we have:

$$\begin{aligned}
(\mathbf{f}_z \otimes 1)(\rho_{i_1, \dots, i_n, z} \otimes \nu_1) &= q^{\binom{nz - \frac{1}{2}(n^2 - n) - (\sum_{j=1}^n i_j)}{[z-n]!}} \frac{([z-n]!)}{([z]!)} (F^n x_{0,z}) \otimes \nu_1 \\
&= q^{\binom{nz - \frac{1}{2}(n^2 - n) - (\sum_{j=1}^n i_j)}{[z-n]!}} \frac{([z-n]!)}{([z]!)} \times \\
&\quad \times \left((F^n x_{0,z-1}) \otimes \nu_{01} + q^{n-z} [n] (F^{n-1} x_{0,z-1}) \otimes \nu_{11} \right)
\end{aligned}$$

$$\begin{aligned}
\mathbf{e}_z(\mathbf{f}_z \otimes 1)(\rho_{i_1, \dots, i_n, z} \otimes \nu_1) &= q^{\binom{nz - \frac{1}{2}(n^2 - n) - (\sum_{j=1}^n i_j)}{[z-n]!}} \frac{([z-n]!)}{([z]!)} \times \\
&\quad \times \left(q(F^n x_{0,z-1}) \otimes \nu_{01} - (F^n x_{0,z-1}) \otimes \nu_{10} \right)
\end{aligned}$$

Let $G_1 := q^{\binom{nz - \frac{1}{2}(n^2 - n) - (\sum_{j=1}^n i_j)}{[z-n]!}} \frac{([z-n]!)}{([z]!)}$, then this becomes:

$$\sum_{1 \leq j_k \leq z-1} q^{\binom{\frac{1}{2}(n^2 + n) - (\sum_{k=1}^n j_k)}{[n]!}} ([n]!) G_1 \left(q \rho_{j_1, \dots, j_n, z-1} \otimes \nu_{01} - \rho_{j_1, \dots, j_n, z-1} \otimes \nu_{10} \right)$$

$$(\mathbf{f}_z \otimes 1) \mathbf{e}_z(\mathbf{f}_z \otimes 1)(\rho_{i_1, \dots, i_n, z} \otimes \nu_1) =$$

$$\begin{aligned}
&\sum_{1 \leq j_k \leq z-1} q^{\binom{\frac{1}{2}(n^2 + n) - (\sum_{k=1}^n j_k)}{[n]!}} ([n]!) G_1 \left(q^{\binom{nz - \frac{1}{2}(n^2 - n) + 1 - (\sum_{k=1}^n j_k)}{[z-n]!}} \frac{([z-n]!)}{([z]!)} (F^n x_{0,z}) \otimes \nu_1 \right. \\
&\quad \left. - q^{\binom{z(n+1) - \frac{1}{2}(n^2 + n) - z - (\sum_{k=1}^n j_k)}{[z-n-1]!}} \frac{([z-n-1]!)}{([z]!)} (F^{n+1} x_{0,z}) \otimes \nu_0 \right)
\end{aligned}$$

Using equation A.22 again, this reduces to:

$$\begin{aligned}
&q^{\binom{\frac{1}{2}(n^2 + n) - n - n(z-1)}{[n]!}} \frac{([n]!)([z-1]!)}{([n]!)([z-n-1]!)} G_1 \left(q^{\binom{nz - \frac{1}{2}(n^2 - n) + 1}{[z-n]!}} \frac{([z-n]!)}{([z]!)} (F^n x_{0,z}) \otimes \nu_1 \right. \\
&\quad \left. - q^{\binom{z(n+1) - \frac{1}{2}(n^2 + n) - z}{[z-n-1]!}} \frac{([z-n-1]!)}{([z]!)} (F^{n+1} x_{0,z}) \otimes \nu_0 \right) \\
&= G_1 \left(q^{n+1} \frac{[z-n]}{[z]} (F^n x_{0,z}) \otimes \nu_1 - \frac{1}{[z]} (F^{n+1} x_{0,z}) \otimes \nu_0 \right) \\
&= q^{\binom{nz - \frac{1}{2}(n^2 - n) - (\sum_{j=1}^n i_j)}{[z-n]!}} \frac{([z-n]!)}{([z]!)} \left(q^{n+1} \frac{[z-n]}{[z]} (F^n x_{0,z}) \otimes \nu_1 - \frac{1}{[z]} (F^{n+1} x_{0,z}) \otimes \nu_0 \right)
\end{aligned}$$

Then we have that:

$$\left(\mathbf{f}_z \otimes 1 - \frac{[z]}{[z+1]} (\mathbf{f}_z \otimes 1) \mathbf{e}_z(\mathbf{f}_z \otimes 1) \right) (\rho_{i_1, \dots, i_n, z} \otimes \nu_1) =$$

$$\begin{aligned}
& q^{\binom{nz-\frac{1}{2}(n^2-n)-(\sum_{j=1}^n i_j)}{}} \frac{([z-n]!)}{([z]!)} (F^n x_{0,z}) \otimes \nu_1 \\
& - q^{\binom{nz-\frac{1}{2}(n^2-n)-(\sum_{j=1}^n i_j)}{}} \frac{([z-n]!)}{([z]!)} \frac{[z]}{[z+1]} \times \\
& \times \left(q^{n+1} \frac{[z-n]}{[z]} (F^n x_{0,z}) \otimes \nu_1 - \frac{1}{[z]} (F^{n+1} x_{0,z}) \otimes \nu_0 \right) \\
& = q^{\binom{nz-\frac{1}{2}(n^2-n)-(\sum_{j=1}^n i_j)}{}} \frac{([z-n]!)}{([z]!)} \times \\
& \times \left(\frac{1}{[z+1]} (F^{n+1} x_{0,z}) \otimes \nu_0 + \left(1 - q^{n+1} \frac{[z-n]}{[z+1]} \right) (F^n x_{0,z}) \otimes \nu_1 \right)
\end{aligned}$$

Note that:

$$\begin{aligned}
[z+1] - q^{n+1}[z-n] &= \frac{(q^{z+1} - q^{-z-1} - q^{n+1}(q^{z-n} - q^{n-z}))}{(q - q^{-1})} \\
&= \frac{q^{2n-z+1} - q^{-z-1}}{(q - q^{-1})} = q^{n-z}[n+1]
\end{aligned}$$

Hence we have:

$$\begin{aligned}
& q^{\binom{nz-\frac{1}{2}(n^2-n)-(\sum_{j=1}^n i_j)}{}} \frac{([z-n]!)}{([z]!)} \left(\frac{1}{[z+1]} (F^{n+1} x_{0,z}) \otimes \nu_0 + q^{n-z} \frac{[n+1]}{[z+1]} (F^n x_{0,z}) \otimes \nu_1 \right) \\
& = q^{\binom{nz-\frac{1}{2}(n^2-n)-(\sum_{j=1}^n i_j)}{}} \frac{([z-n]!)}{([z+1]!)} \left((F^{n+1} x_{0,z}) \otimes \nu_0 + q^{n-z}[n+1] (F^n x_{0,z}) \otimes \nu_1 \right) \\
& = \mathbf{f}_{z+1}(\rho_{i_1, \dots, i_n, z} \otimes \nu_1)
\end{aligned}$$

Hence we have shown that the projections \mathbf{f}_z satisfy the Jones-Wenzl recurrence relation.

Since the projection $\mathbf{f}_1 : X \rightarrow \mathcal{X}_2^+ \rightarrow X$ is just the identity, then we have shown that the projection $\mathbf{f}_z : X^{\otimes z} \rightarrow \mathcal{X}_{z+1}^+ \rightarrow X^{\otimes z}$ is the Jones-Wenzl projection.

Appendix C

An alternate proof of the diagrammatic formula for the Second Endomorphism on \mathcal{P}_i^+

$End(\mathcal{P}_i^+)$ is 2-dimensional, with basis $\{1, \varepsilon\}$, with the second map given by $\varepsilon(\tilde{b}_j) = \tilde{a}_j$, $\varepsilon(\tilde{a}_j) = \varepsilon(\tilde{x}_k) = \varepsilon(\tilde{y}_k) = 0$. We can therefore construct a map:

$$\Phi_i : X^{\otimes 2p-i-1} \rightarrow \mathcal{P}_i^+ \xrightarrow{\tilde{b}_j \mapsto \tilde{a}_j} \mathcal{P}_i^+ \rightarrow X^{\otimes 2p-i-1}$$

This is given by:

$$\begin{aligned} \Phi_i(\rho_{i_1, \dots, i_n, 2p-i-1}) &= (-1)^{p-i-1} q^{\binom{n(2p-i-1) - \frac{1}{2}(n^2-n) - (\sum_{j=1}^n i_j)}{}} \times \\ &\quad \times \frac{([n]!)([p-n-1]!)}{([n+i-p]!)([p-i-1]!)^2([i-1]!)} F^n x_{0, 2p-i-1}, \\ &\quad p-i \leq n \leq p-1 \\ \Phi_i(\rho_{i_1, \dots, i_n, 2p-i-1}) &= 0, \quad n < p-i, \quad n > p-1 \end{aligned}$$

We want to prove that Φ can be given diagrammatically in terms of the $(p-1)$ th Jones-Wenzl projection by the following:

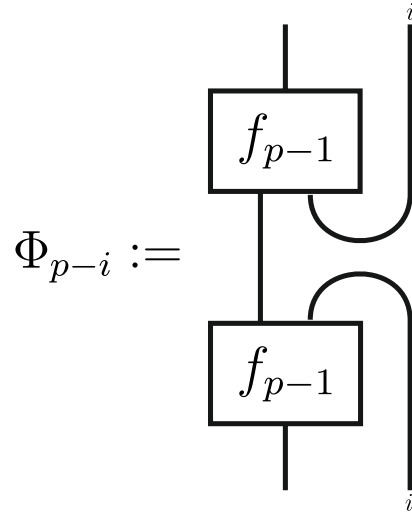

To prove this, we first show that taking the partial trace of Φ_i gives Φ_{i+1} . We then prove explicitly the case Φ_1 .

C.1 The partial trace of the second endomorphism

We want to show that taking the partial trace of Φ_i gives Φ_{i+1} .

Diagrammatically this is:

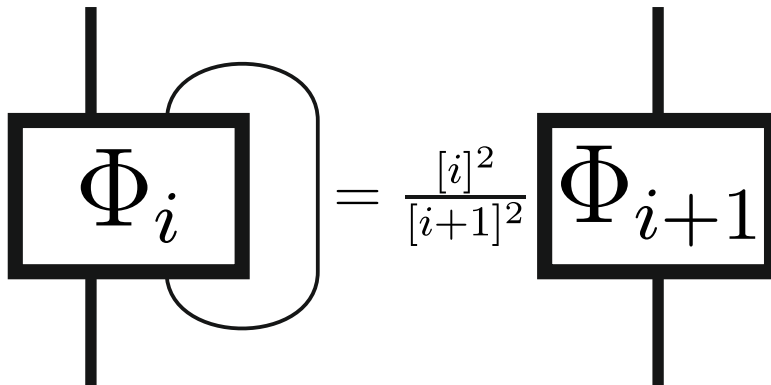

Using equation A.20, we have $F^n x_{0,z+1} = (F^n x_{0,z}) \otimes \nu_0 + q^{n-1-z} [n] (F^{n-1} x_{0,z}) \otimes \nu_1$.

Consider $X^{\otimes 2p-i-2} \otimes \cap$. Its elements take the form

$$q^{-1} \rho_{i_1, \dots, i_n, 2p-i-2} \otimes \nu_{10} - \rho_{i_1, \dots, i_n, 2p-i-2} \otimes \nu_{01}.$$

$\Phi_i \otimes 1$ is non-zero on $\rho_{i_1, \dots, i_n, 2p-i-2} \otimes \nu_{10}$ for $p-i-1 \leq n \leq p-2$ and on $\rho_{i_1, \dots, i_n, 2p-i-2} \otimes \nu_{01}$ for $p-i \leq n \leq p-1$.

For $n = p - i - 1$, we have $\Phi_i(q^{-1}\rho_{i_1, \dots, i_n, 2p-i-2} \otimes \nu_1) =$

$$\begin{aligned} & (-1)^{p-i-1} q^{\binom{(p-i)(2p-i-1) - \frac{1}{2}(p-i)(p-i-1) - (2p-i-1) - 1 - \binom{p-i-1}{j=1} i_j}{}} \times \\ & \times \frac{([p-i]!)([i-1]!)}{([p-i-1]!)^2([i-1]!)} F^{p-i} x_{0, 2p-i-1} \\ & = (-1)^{p-i-1} q^{\binom{(p-i-1)(2p-i-1) - \frac{1}{2}(p-i)(p-i-1) - 1 - \binom{p-i-1}{j=1} i_j}{}} \times \\ & \times \frac{[p-i]}{([p-i-1]!)} F^{p-i} x_{0, 2p-i-1} \end{aligned}$$

Using equation A.20, we have $(\Phi_i \otimes 1)(q^{-1}\rho_{i_1, \dots, i_{p-i-1}, 2p-i-2} \otimes \nu_{10}) =$

$$\begin{aligned} & (-1)^{p-i-1} q^{\binom{(p-i-1)(2p-i-1) - \frac{1}{2}(p-i)(p-i-1) - 1 - \binom{p-i-1}{j=1} i_j}{}} \times \\ & \times \frac{[p-i]}{([p-i-1]!)} (F^{p-i} x_{0, 2p-i-1}) \otimes \nu_0 \\ & = (-1)^{p-i-1} q^{\binom{(p-i-1)(2p-i-1) - \frac{1}{2}(p-i)(p-i-1) - 1 - \binom{p-i-1}{j=1} i_j}{}} \times \\ & \times \frac{[p-i]}{([p-i-1]!)} \left((F^{p-i} x_{0, 2p-i-2}) \otimes \nu_{00} + q^{1-p} [p-i] (F^{p-i-1} x_{0, 2p-i-2}) \otimes \nu_{10} \right) \end{aligned}$$

Acting $1^{\otimes p+i-2} \otimes \cup$ on this we get:

$$\begin{aligned} & (-1)^{p-i-1} q^{\binom{(p-i-1)(2p-i-1) - \frac{1}{2}(p-i)(p-i-1) - p - \binom{p-i-1}{j=1} i_j}{}} \times \\ & \times \frac{[p-i]^2}{([p-i-1]!)} F^{p-i-1} x_{0, 2p-i-2} \\ & = (-1)^{p-i-2} q^{\binom{(p-i-1)(2p-i-1) - \frac{1}{2}(p-i)(p-i-1) - \binom{p-i-1}{j=1} i_j}{}} \times \\ & \times \frac{[p-i]^2}{([p-i-1]!)} F^{p-i-1} x_{0, 2p-i-2} \\ & = \frac{[p-i]^2}{[p-i-1]^2} \Phi_{i+1}(\rho_{i_1, \dots, i_{p-i-1}, 2p-i-2}) \\ & = \frac{[i]^2}{[i+1]^2} \Phi_{i+1}(\rho_{i_1, \dots, i_{p-i-1}, 2p-i-2}) \end{aligned}$$

For $n = p - 1$, we have $\Phi_i(-\rho_{i_1, \dots, i_n, 2p-i-2} \otimes \nu_0) =$

$$\begin{aligned} & (-1)^{p-i-2} q^{\binom{(p-1)(2p-i-1) - \frac{1}{2}(p-1)(p-2) - \binom{p-1}{j=1} i_j}{}} \times \\ & \times \frac{([p-1]!)}{([p-i-1]!)^2([i-1]!)^2} F^{p-1} x_{0, 2p-i-1} \end{aligned}$$

Again using equation A.20, we have $(\Phi_i \otimes 1)(-\rho_{i_1, \dots, i_{p-1}, 2p-i-2} \otimes \nu_{01}) =$

$$\begin{aligned} & (-1)^{p-i-2} q^{\binom{(p-1)(2p-i-1) - \frac{1}{2}(p-1)(p-2) - (\sum_{j=1}^{p-1} i_j)}{}} \times \\ & \times \frac{([p-1]!)}{([p-i-1]!)^2([i-1]!)^2} (F^{p-1} x_{0,2p-i-1}) \otimes \nu_1 \\ = & (-1)^{p-i-2} q^{\binom{(p-1)(2p-i-1) - \frac{1}{2}(p-1)(p-2) - (\sum_{j=1}^{p-1} i_j)}{}} \times \\ & \times \frac{([p-1]!)}{([p-i-1]!)^2([i-1]!)^2} \left((F^{p-1} x_{0,2p-i-2}) \otimes \nu_{01} + q^i [p-1] (F^{p-2} x_{0,2p-i-2}) \otimes \nu_{11} \right) \end{aligned}$$

Acting $1^{\otimes p+i-2} \otimes \cup$ on this we get:

$$\begin{aligned} & (-1)^{p-i-3} q^{\binom{(p-1)(2p-i-1) - \frac{1}{2}(p-1)(p-2) + 1 - (\sum_{j=1}^{p-1} i_j)}{}} \times \\ & \times \frac{([p-1]!)}{([p-i-1]!)^2([i-1]!)^2} F^{p-1} x_{0,2p-i-2} \\ = & \frac{[i]^2}{[p-i-1]^2} \Phi_{i+1}(\rho_{i_1, \dots, i_{p-1}, 2p-i-2}) \\ = & \frac{[i]^2}{[i+1]^2} \Phi_{i+1}(\rho_{i_1, \dots, i_{p-1}, 2p-i-2}) \end{aligned}$$

Finally, for $p-i \leq n \leq p-2$, we have $\Phi_i(q^{-1} \rho_{i_1, \dots, i_n, 2p-i-2} \otimes \nu_1 - \rho_{i_1, \dots, i_n, 2p-i-2} \otimes \nu_0) =$

$$\begin{aligned} & (-1)^{p-i-1} q^{\binom{(n+1)(2p-i-1) - \frac{1}{2}(n^2+n) - (2p-i-1) - 1 - (\sum_{j=1}^n i_j)}{}} \times \\ & \times \frac{([n+1]!)([p-n-2]!)}{([n+1+i-p]!)([p-i-1]!)^2([i-1]!)} F^{n+1} x_{0,2p-i-1} \\ + & (-1)^{p-i-2} q^{\binom{n(2p-i-1) - \frac{1}{2}(n^2-n) - (\sum_{j=1}^n i_j)}{}} \times \\ & \times \frac{([n]!)([p-n-1]!)}{([n+i-p]!)([p-i-1]!)^2([i-1]!)} F^n x_{0,2p-i-1} \\ = & (-1)^{p-i-1} q^{\binom{n(2p-i-1) - \frac{1}{2}(n^2-n) - (\sum_{j=1}^n i_j)}{}} \frac{([n]!)([p-n-1]!)}{([n+i-p]!)([p-i-1]!)^2([i-1]!)} \times \\ & \times \left(q^{-n-1} \frac{[n+1]}{[n+1+i-p][p-n-1]} F^{n+1} x_{0,2p-i-1} - F^n x_{0,2p-i-1} \right) \end{aligned}$$

Using equation A.20, we have $(\Phi_i \otimes 1)(q^{-1} \rho_{i_1, \dots, i_n, 2p-i-2} \otimes \nu_{10} - \rho_{i_1, \dots, i_n, 2p-i-2} \otimes \nu_{01}) =$

$$\begin{aligned} & (-1)^{p-i-1} q^{\binom{n(2p-i-1) - \frac{1}{2}(n^2-n) - (\sum_{j=1}^n i_j)}{}} \frac{([n]!)([p-n-1]!)}{([n+i-p]!)([p-i-1]!)^2([i-1]!)} \times \\ & \times \left(q^{-n-1} \frac{[n+1]}{[n+1+i-p][p-n-1]} (F^{n+1} x_{0,2p-i-1}) \otimes \nu_0 - (F^n x_{0,2p-i-1}) \otimes \nu_1 \right) \\ = & (-1)^{p-i-1} q^{\binom{n(2p-i-1) - \frac{1}{2}(n^2-n) - (\sum_{j=1}^n i_j)}{}} \frac{([n]!)([p-n-1]!)}{([n+i-p]!)([p-i-1]!)^2([i-1]!)} \times \\ & \times \left(q^{-n-1} \frac{[n+1]}{[n+1+i-p][p-n-1]} (F^{n+1} x_{0,2p-i-2}) \otimes \nu_{00} \right. \\ & + q^{i-2p+1} \frac{[n+1]^2}{[n+1+i-p][p-n-1]} (F^n x_{0,2p-i-2}) \otimes \nu_{10} \\ & \left. - (F^n x_{0,2p-i-2}) \otimes \nu_{01} - q^{n-2p+i} [n-1] (F^{n-1} x_{0,2p-i-2}) \otimes \nu_{11} \right) \end{aligned}$$

Acting $1^{\otimes p+i-2} \otimes \cup$ on this we get:

$$\begin{aligned} & (-1)^{p-i-1} q^{\left(n(2p-i-1) - \frac{1}{2}(n^2-n) - \left(\sum_{j=1}^n i_j\right)\right)} \frac{([n]!)([p-n-1]!)}{([n+i-p]!)([p-i-1]!)^2([i-1]!)} \times \\ & \times \left(q^{i+1} \frac{[n+1]^2}{[n+1+i-p][p-n-1]} + q \right) F^n x_{0,2p-i-2} \end{aligned}$$

We now need the following simplification:

$$\begin{aligned} q^i \frac{[n+1]^2}{[n+1+i-p][p-n-1]} + 1 &= \frac{q^i[n+1]^2 + [n+1+i-p][p-n-1]}{[n+1+i-p][p-n-1]} \\ &= \frac{q^i[n+1] + [n+1+i-p]}{[n+1+i-p]} \\ q^i[n+1] + [n+1+i-p] &= (q - q^{-1})^{-1} \left(q^{n+i+1} - q^{i-n-1} + q^{n+1+i-p} - q^{p-i-n-1} \right) \\ &= (q - q^{-1})^{-1} \left(q^{n+i+1} - q^{i-n-1} - q^{n+i+1} + q^{-i-n-1} \right) \\ &= (q - q^{-1})^{-1} (q^{-i-n-1} - q^{i-n-1}) = -q^{-n-1}[i] \end{aligned}$$

Therefore $q^i \frac{[n+1]^2}{[n+1+i-p][p-n-1]} + 1 = -q^{-n-1} \frac{[i]}{[n+1+i-p]}$. Hence we have:

$$\begin{aligned} & (-1)^{p-i-1} q^{\left(n(2p-i-1) - \frac{1}{2}(n^2-n) - \left(\sum_{j=1}^n i_j\right)\right)} \frac{([n]!)([p-n-1]!)}{([n+i-p]!)([p-i-1]!)^2([i-1]!)} \times \\ & \times \left(q^{i+1} \frac{[n+1]^2}{[n+1+i-p][p-n-1]} + q \right) F^n x_{0,2p-i-2} \\ &= (-1)^{p-i-2} q^{\left(n(2p-i-1) - \frac{1}{2}(n^2-n) - n - \left(\sum_{j=1}^n i_j\right)\right)} \frac{([n]!)([p-n-1]!)}{([n+i-p]!)([p-i-1]!)^2([i-1]!)} \times \\ & \times \frac{[i]}{[n+1+i-p]} F^n x_{0,2p-i-2} \\ &= \frac{[i]^2}{[p-i-1]^2} \Phi_{i+1}(\rho_{i_1, \dots, i_n, 2p-i-2}) \\ &= \frac{[i]^2}{[i+1]^2} \Phi_{i+1}(\rho_{i_1, \dots, i_n, 2p-i-2}) \end{aligned}$$

Hence we have shown that the partial trace of Φ_i is Φ_{i+1} .

C.2 The second endomorphism on \mathcal{P}_1^+

We now want to prove that Φ_1 is given diagrammatically by:

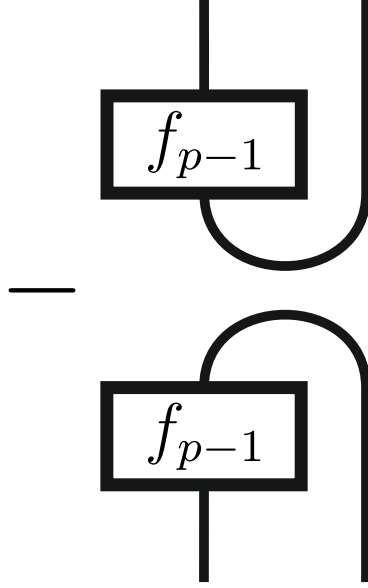

Explicitly, Φ_1 is given by:

$$\Phi_1(\rho_{i_1, \dots, i_{p-1}, 2p-2}) = (-1)^{p-2} q^{\binom{(p-1)(2p-2) - \frac{1}{2}(p-1)(p-2) - (\sum_{j=1}^{p-1} i_j)}{}} \frac{([p-1]!)}{([p-2]!)^2} F^{p-1} x_{0, 2p-2}$$

$$\Phi_1(\rho_{i_1, \dots, i_n, 2p-2}) = 0, \quad n \neq p-1$$

The z th Jones-Wenzl projection \mathbf{f}_z onto the module \mathcal{X}_{z+1}^+ in $X^{\otimes z}$ is given by:

$$\mathbf{f}_z(\rho_{i_1, \dots, i_n, z}) = q^{\binom{nz - \frac{1}{2}(n^2 - n) - (\sum_{j=1}^n i_j)}{}} \frac{([z-n]!)}{([z]!)} F^n x_{0, z}$$

Consider applying $\mathbf{f}_{p-1} \otimes 1^{\otimes p-1}$ to $\rho_{i_1, \dots, i_n, p-1} \otimes \rho_{j_1, \dots, j_m, p-1}$. We have

$$(\mathbf{f}_{p-1} \otimes 1^{\otimes p-1})(\rho_{i_1, \dots, i_n, p-1} \otimes \rho_{j_1, \dots, j_m, p-1}) =$$

$$q^{\binom{n(p-1) - \frac{1}{2}(n^2 - n) - (\sum_{j=1}^n i_j)}{}} \frac{([p-1-n]!)}{([p-1]!)} (F^n x_{0, p-1}) \otimes \rho_{j_1, \dots, j_m, p-1}$$

$$= \sum_{k_1, \dots, k_n} q^{\binom{np - (\sum_{j=1}^n i_j) - (\sum_{l=1}^n k_l)}{}} \frac{([p-1-n]!)([n]!)}{([p-1]!)} \rho_{k_1, \dots, k_n, p-1} \otimes \rho_{j_1, \dots, j_m, p-1}$$

Given $\cup(\nu_{10}) = \nu$, $\cup(\nu_{01}) = -q\nu$, $\cup(\nu_{00}) = \cup(\nu_{11}) = 0$, applying cups repeatedly to this, we get zero if $m+n \neq p-1$ or if $\{k_1, \dots, k_n\} \cap \{p-j_1, \dots, p-j_m\} \neq \emptyset$. If $m+n = p-1$ and $\{k_1, \dots, k_n\} \cap \{p-j_1, \dots, p-j_m\} = \emptyset$, then we have:

$$\sum_{k_1, \dots, k_n} (-1)^{p-1-n} q^{\binom{np+p-1-n - (\sum_{j=1}^n i_j) - (\sum_{l=1}^n k_l)}{}} \frac{([p-1-n]!)([n]!)}{([p-1]!)} \nu$$

$$= \sum_{k_1, \dots, k_n} (-1)^{p-1} q^{\binom{p-1-n - (\sum_{j=1}^n i_j) - (\sum_{l=1}^n k_l)}{}} \nu$$

Note that for each choice of j_1, \dots, j_m , there is a unique choice of k_1, \dots, k_n satisfying the above conditions, i.e. $\{k_1, \dots, k_n, p - j_1, \dots, p - j_m\} = \{1, \dots, p - 1\}$, and so we have that:

$$\sum_{l=1}^n k_l = \frac{1}{2}(p^2 - p) - mp + \sum_{r=1}^m j_r$$

$$\begin{aligned} \text{Hence we have } \sum_{k_1, \dots, k_n} (-1)^{p-1} q^{\binom{p-1-n-(\sum_{j=1}^n i_j)-(\sum_{l=1}^n k_l)}{\nu}} &= \\ &= (-1)^{p-1} q^{\binom{p-1-n-(\sum_{j=1}^n i_j)-\frac{1}{2}(p^2-p)+mp-(\sum_{r=1}^m j_r)}{\nu}} \\ &= (-1)^{p-1} q^{\binom{(p+1)(p-1-n)-\frac{1}{2}(p^2-p)-(\sum_{j=1}^n i_j)-(\sum_{r=1}^m j_r)}{\nu}} \\ &= (-1)^{p-1} q^{\binom{(p+1)(p-1-n)-\frac{1}{2}(p^2-p)+(p-1)(p-1-n)-(\sum_{j=1}^{p-1} i_j)}{\nu}} \\ &= (-1)^{p-1} q^{\binom{2p(p-1-n)-\frac{1}{2}(p^2-p)-(\sum_{j=1}^{p-1} i_j)}{\nu}} \\ &= (-1)^{p-1} q^{\binom{-\frac{1}{2}(p^2-p)-(\sum_{j=1}^{p-1} i_j)}{\nu}} \end{aligned}$$

where $i_{n+r} = j_r + p - 1$.

Given $\rho_{i_1, \dots, i_n, z}$, let $\tilde{i}_1, \dots, \tilde{i}_{z-n}$ be the positions of the zeros. As $\cap(\nu) = q^{-1}\nu_{10} - \nu_{01}$, we have that the z -fold cap is given by:

$$\sum_{n=0}^z \left(\sum_{i_1, \dots, i_n} (-1)^{z-n} q^{-n} \rho_{i_1, \dots, i_n, 2z+1-\tilde{i}_{z-n}, \dots, 2z+1-\tilde{i}_1, 2z} \right)$$

Taking $z = p - 1$, this becomes:

$$\sum_{n=0}^{p-1} \left(\sum_{i_1, \dots, i_n} (-1)^{p-1-n} q^{-n} \rho_{i_1, \dots, i_n, 2p-1-\tilde{i}_{p-1-n}, \dots, 2p-1-\tilde{i}_1, 2p-2} \right)$$

Applying $\mathbf{f}_{p-1} \otimes 1^{\otimes p-1}$ to this we get:

$$\begin{aligned} & \sum_{n=0}^{p-1} \left(\sum_{i_1, \dots, i_n} (-1)^{p-1-n} q^{\binom{n(p-2)-\frac{1}{2}(n^2-n)-(\sum_{j=1}^n i_j)}{\nu}} \times \right. \\ & \quad \left. \times \frac{([p-1-n]!)}{([p-1]!)} (F^n x_{0,p-1}) \otimes \rho_{p-\tilde{i}_{p-1-n}, \dots, p-\tilde{i}_1, p-1} \right) \\ &= \sum_{n=0}^{p-1} \left(\sum_{i_1, \dots, i_n} \sum_{j_1, \dots, j_n} (-1)^{p-1-n} q^{\binom{n(p-1)-(\sum_{j=1}^n i_j)-(\sum_{k=1}^n j_k)}{\nu}} \times \right. \\ & \quad \left. \times \frac{([p-1-n]!)([n]!)}{([p-1]!)} \rho_{j_1, \dots, j_n, p-1} \otimes \rho_{p-\tilde{i}_{p-1-n}, \dots, p-\tilde{i}_1, p-1} \right) \end{aligned}$$

$$\begin{aligned}
&= \sum_{n=0}^{p-1} \left(\left(\sum_{i_1, \dots, i_n} \sum_{j_1, \dots, j_n} (-1)^{p-1-n} q^{\left(n(p-1) - \frac{1}{2}(p^2-p) + (2p-1)(p-1-n) - 1 + p - \frac{1}{2}(p-1)(p-2) \right)} \right) \times \right. \\
&\quad \times q^{\left(p-1 + \frac{1}{2}(p-1)(p-2) - (2p-1)(p-1-n) - \left(\sum_{k=1}^n j_k \right) + \left(\sum_{j=1}^{p-1-n} \tilde{i}_j \right) \right)} \\
&\quad \times \left. \frac{([p-1-n]!)([n]!)}{([p-1]!)^2} ([p-1]!) \rho_{j_1, \dots, j_n, 2p-1-\tilde{i}_{p-1-n}, \dots, 2p-1-\tilde{i}_1, 2p-2} \right) \\
&= \sum_{n=0}^{p-1} \left(\sum_{k_1, \dots, k_{p-1}} (-1)^{p-1-n} q^{\left(np + (p-1)^2 \right)} \frac{q^{\left(p-1 + \frac{1}{2}(p-1)(p-2) - \left(\sum_{l=1}^{p-1} k_l \right) \right)}}{([p-1]!)^2} ([p-1]!) \rho_{k_1, \dots, k_{p-1}, 2p-2} \right) \\
&= q^{(p-1)^2} \frac{(-1)^{p-1}}{([p-1]!)^2} F^{p-1} x_{0, 2p-2}
\end{aligned}$$

Where we have taken $k_1 := j_1, \dots, k_n := j_n, k_{n+1} := 2p-1-\tilde{i}_{p-1-n}, \dots, k_{p-1} := 2p-1-\tilde{i}_1$.

Combining this with the first part we get:

$$\begin{aligned}
& q^{\left(\frac{1}{2}(9p^2-7p+2) - \left(\sum_{j=1}^{p-1} i_j \right) \right)} \frac{(-1)^{2p-2}}{([p-1]!)^2} F^{p-1} x_{2p-2} \\
&= q^{\left(3p^2-p + \frac{1}{2}(3p^2-5p+2) - \left(\sum_{j=1}^{p-1} i_j \right) \right)} \frac{(-1)^{-2}}{([p-1]!)^2} F^{p-1} x_{2p-2} \\
&= q^{\left(\frac{1}{2}(3p^2-5p+2) - \left(\sum_{j=1}^{p-1} i_j \right) \right)} \frac{(-1)^{p-1}}{([p-1]!)^2} F^{p-1} x_{2p-2} \\
&= -\Phi_1
\end{aligned}$$

Bibliography

- [1] Y. Arike. A construction of symmetric linear functions on the restricted quantum group $\bar{U}_q(\mathfrak{sl}_2)$. *Osaka J. Math.*, 47:535–557, 2010.
- [2] S. Bigelow. Skein theory for the ADE planar algebras. *Journal of Pure and Applied Algebra*, 214(5):658–666, 2010.
- [3] J. Bion-Nadal. An example of a subfactor of the hyperfinite II_1 factor whose principal graph invariant is the Coxeter graph E_6 . In *Current topics in Operator Algebras*, pages 104–113. World Sci. Publ., River Edge, NJ, 1991.
- [4] D. Bisch. *Combinatorial and Analytical Aspects of the Jones Theory of Subfactors*. <http://books.google.co.uk/books?id=N4UAcgAACAAJ>, 1996.
- [5] D. Bisch and V. Jones. Algebras associated to intermediate subfactors. *Inventiones Mathematicae*, 128(1):89–157, 1997.
- [6] J. Böckenhauer and D. E. Evans. Modular invariants and subfactors. *Mathematical physics in mathematics and physics*, Fields Inst. Commun., 30:11–37, 2000.
- [7] T. Booker and A. Davydov. Commutative algebras in Fibonacci categories. *Journal of Algebra*, 355(1):176–204, 2012.
- [8] R. Burnstein. Automorphisms of the bipartite graph planar algebra. *Journal of Functional Analysis*, 259(9):2384–2403, 2010.
- [9] D. Calaque and P. Etingof. Lectures on tensor categories. *IRMA Lectures in Mathematics and Theoretical Physics*, 12:1–38, 2008.
- [10] F. Calegari, S. Morrison, and N. Snyder. Cyclotomic integers, fusion categories, and subfactors. *Communications in Mathematical Physics*, 303, Issue 3:845–896, 2010.
- [11] V. Chari and A. Premet. Indecomposable restricted representations of quantum \mathfrak{sl}_2 . *Publ. RIMS*, 30:335–352, 1994.

- [12] V. Chari and A. Pressley. *A Guide to Quantum Groups*. Cambridge University Press, 1995.
- [13] B. Cooper. *Almost Koszul Duality and Rational Conformal Field Theory*. PhD thesis, University of Bath, 2007.
- [14] K. Das. Automorphisms of bipartite graph planar algebras and their subfactor planar algebras. Master’s thesis, The Institute of Mathematical Sciences, Chennai, 2011. M.Sc Thesis.
- [15] V. Drinfeld, S. Gelaki, D. Nikshych, and V. Ostrik. On braided fusion categories 1. *Selecta Mathematica*, 16:1–119, 2010.
- [16] P. Etingof, D. Nikshych, and V. Ostrik. On fusion categories. *Ann. of Math. (2)*, 162(2):581–642, 2005.
- [17] D. E. Evans. Fusion rules of modular invariants. *Reviews in Mathematical Physics*, 14:709–731, 2002.
- [18] D. E. Evans and T. Gannon. Non-unitary fusion categories and their doubles via endomorphisms. *arxiv.org/abs/1506.03546*, June 2015.
- [19] D. E. Evans and Y. Kawahigashi. *Quantum Symmetries on Operator Algebras*. Oxford Mathematical Monographs, 1997.
- [20] D. E. Evans and M. Pugh. A_2 -Planar algebras 1. *Quantum Topology*, 1(4):321–377, 2010.
- [21] D. E. Evans and M. Pugh. The Nakayama automorphism of the almost Calabi-Yau algebras associated to $SU(3)$ modular invariants. *Communications in Mathematical Physics*, 312:179–222, 2012.
- [22] B. Feigin, A. Gainutdinov, A. Semikhatov, and I. Tipunin. Kazhdan-Lusztig correspondence for the representation category of the triplet W -algebra in logarithmic CFT. *Theor. Math. Phys.*, 148:398–427, 2006.
- [23] B. Feigin, A. Gainutdinov, A. Semikhatov, and I. Tipunin. Modular group representations and fusion in logarithmic conformal field theories and in the quantum group center. *Commun. Math. Phys.*, 265:47–93, 2006.

- [24] I. B. Frenkel and M. G. Khovanov. Canonical bases in tensor products and graphical calculus for $U_q(\mathfrak{sl}_2)$. *Duke Mathematical Journal*, 87:409–480, 1997.
- [25] A. M. Gainutdinov, H. Saleur, and I. Y. Tipunin. Lattice W-algebras and logarithmic CFTs. *Journal of Physics A: Mathematical and Theoretical*, 47(49), 2014.
- [26] F. M. Goodman and H. Wenzl. Ideals in the Temperley-Lieb category, appendix to: A magnetic model with a possible Chern-Simons phase. *Communications in Mathematical Physics*, 234:129–183, 2007.
- [27] U. Haagerup. Principal graphs of subfactors in the index range $4 < [M : N] < 3 + \sqrt{2}$. In *Subfactors*, pages 1–38. World Sci. Publ., River Edge, NJ, 1994.
- [28] E. Ibanez. *Evaluable Jones-Wenzl idempotents at root of unity and modular representation on the center of $\bar{U}_q\mathfrak{sl}(2)$* . PhD thesis, University of Montpellier, 2016.
- [29] M. Izumi. Application of fusion rules to classification of subfactors. *Publications of the Research Institute for Mathematical Sciences*, 27(6):953–994, 1991.
- [30] M. Izumi. On flatness of the Coxeter graph E_8 . *Pacific Journal of Mathematics*, 166(2):305–327, 1994.
- [31] V. Jones and D. Penneys. The embedding theorem for finite depth subfactor planar algebras. *Quantum Topology*, pages 301–337, 2011.
- [32] V. Jones. and S. Sunder. *Introduction to Subfactors*. London Mathematical Society Lecture Notes Series, 1997.
- [33] V. F. R. Jones. Index for subfactors. *Invent Math*, 72(1):1–25, 1983.
- [34] V. F. R. Jones. The planar algebra of a bipartite graph. In *Knots in Hellas '98 (Delphi)*, *World Scientific*, pages 94–117, 1999.
- [35] V. F. R. Jones. Planar algebras, 1. *arXiv:math/9909027*, 2007.
- [36] V. F. R. Jones. Notes on von Neumann algebras and subfactors. <http://math.berkeley.edu/vfr/math20909.html>, 2010. Lecture Notes.
- [37] V. F. R. Jones, S. Morrison, and N. Snyder. The classification of subfactors of index at most 5. *Bulletin of the American Mathematical Society*, 51:277–327, 2014.
- [38] R. V. Kadison and J. R. Ringrose. *Fundamentals of the Theory of Operator Algebras*. American Mathematical Society, 1983.

- [39] C. Kassel. *Quantum Groups*. Springer New York, 1995.
- [40] L. H. Kauffman. State models and the Jones polynomial. *Topology*, 26(3):395–407, 1987.
- [41] Y. Kawahigashi. On flatness of Ocneanu’s connections on the Dynkin diagrams and classification of subfactors. *Journal of Functional Analysis*, 127(1):63–107, 1995.
- [42] H. Kondo and Y. Saito. Indecomposable decomposition of tensor products of modules over the restricted quantum universal enveloping algebra associated to \mathfrak{sl}_2 . *Journal of Algebra*, 330:103–129, 2011.
- [43] G. Kuperberg. Spiders for rank 2 Lie algebras. *Communications in Mathematical Physics*, 180(1):109–151, 1996.
- [44] S. Majid. *A Quantum Groups Primer*. Cambridge University Press, 2002.
- [45] P. P. Martin. On Schur-Weyl duality, A_n Hecke algebras and quantum $sl(N)$ on $\otimes^{n+1}\mathbb{C}^N$. *International Journal of Modern Physics A*, 07(supp01b):645–673, 1992.
- [46] G. Moore and N. Seiberg. *Lectures on RCFT*, pages 263–361. Springer US, Boston, MA, 1990.
- [47] S. Morrison. *A Diagrammatic Category for the Representation Theory of $U_q(\mathfrak{sl}_n)$* . PhD thesis, University of California, Berkeley, 2007.
- [48] S. Morrison, E. Peters, and N. Snyder. Skein theory for the D_{2n} planar algebras. *Journal of Pure and Applied Algebra*, 214(2):117–139, 2010.
- [49] M. Müger. Tensor categories: A selective guided tour. *Revista de la Unión Matemática Argentina*, 51(1):95–163, 2010.
- [50] F. J. Murray and J. Von Neumann. On rings of operators. *Ann. of Math. (2)*, 37(1):116–229, 1936.
- [51] F. J. Murray and J. von Neumann. On rings of operators. IV. *Ann. of Math. (2)*, 44:716–808, 1943.
- [52] K. Nagatomo and A. Tsuchiya. The triplet vertex operator algebra $W(p)$ and the restricted quantum group $\bar{U}_q(\mathfrak{sl}_2)$ at $q = e^{\frac{\pi i}{p}}$. *arXiv:0902.4607*, 2009.

- [53] A. Ocneanu. Quantized groups, string algebras and Galois theory for algebras. *Operator Algebras and Applications*, 2:119–172, 1989. Web: <http://dx.doi.org/10.1017/CBO9780511662287.008>.
- [54] V. Ostrik. On formal codegrees of fusion categories. *Mathematical Research Letters*, 16(5), 2009.
- [55] G. K. Pedersen. *C*-Algebras and their Automorphism Groups*. London Mathematical Society, 1979.
- [56] S. Popa. Classification of subfactors: the reduction to commuting squares. *Invent Math*, 101(1):19–43, 1990.
- [57] S. Popa. Classification of amenable subfactors of type II. *Acta Math.*, 172(2):163–255, 1994.
- [58] S. Popa. An axiomatization of the lattice of higher relative commutants of a subfactor. *Invent Math*, 120(1):427–445, 1995.
- [59] E. Rowell, R. Stong, and Z. Wang. On classification of modular tensor categories. *Communications in Mathematical Physics*, 292(2):343–389, 2007.
- [60] R. Suter. Modules over $U_q(sl_2)$. *Communications in Mathematical Physics*, 163:359–393, 1994.
- [61] M. Takesaki. *Theory of Operator Algebras 1*. Encyclopaedia of Mathematical Sciences, 1979.
- [62] H. N. V. Temperley and E. H. Lieb. Relations between the 'percolation' and 'colouring' problem and other graph-theoretical problems associated with regular planar lattices: Some exact results for the 'percolation' problem. *Proceedings of the Royal Society of London. Series A, Mathematical and Physical Sciences*, 322(1549):251–280, 1971.
- [63] A. Tsuchiya and S. Wood. The tensor structure on the representation category of the \mathcal{W}_p triplet algebra. *J. Phys. A: Math. Theor.*, 46, 2012.
- [64] H. Wenzl. On sequences of projections. *C. R. Math. Rep. Acad. Sci. Canada*, 9(1):5–9, 1987.

- [65] J. Xiao. Finite dimensional representations of $U_t(sl(2))$ at roots of unity. *Canadian Journal of Mathematics*, 1997.
- [66] S. Yamagami. A categorical and diagrammatical approach to Temperley-Lieb algebras. *arXiv:math/0405267*, 2007.